



**US Army Corps
of Engineers**

Waterways Experiment
Station

Technical Report DOER-1
June 1998

Dredging Operations and Environmental Research Program

Guidance for Subaqueous Dredged Material Capping

*by Michael R. Palermo, James E. Clausner, Marian P. Rollings
Gregory L. Williams, Tommy E. Myers, WES
Thomas J. Fredette, New England District
Robert E. Randall, Texas A&M University*

WES

Approved For Public Release; Distribution Is Unlimited

Prepared for Headquarters, U.S. Army Corps of Engineers



The contents of this report are not to be used for advertising, publication, or promotional purposes. Citation of trade names does not constitute an official endorsement or approval of the use of such commercial products.

The findings of this report are not to be construed as an official Department of the Army position, unless so designated by other authorized documents.



PRINTED ON RECYCLED PAPER

Guidance for Subaqueous Dredged Material Capping

by Michael R. Palermo, James E. Clausner, Marian P. Rollings
Gregory L. Williams, Tommy E. Myers

U.S. Army Corps of Engineers
Waterways Experiment Station
3909 Halls Ferry Road
Vicksburg, MS 39180-6199

Thomas J. Fredette

U.S. Army Engineer District, New England
696 Virginia Road
Concord, MA 01742-2751

Robert E. Randall

Texas A&M University
College Station, TX 77843

Final report

Approved for public release; distribution is unlimited



**US Army Corps
of Engineers**
Waterways Experiment
Station

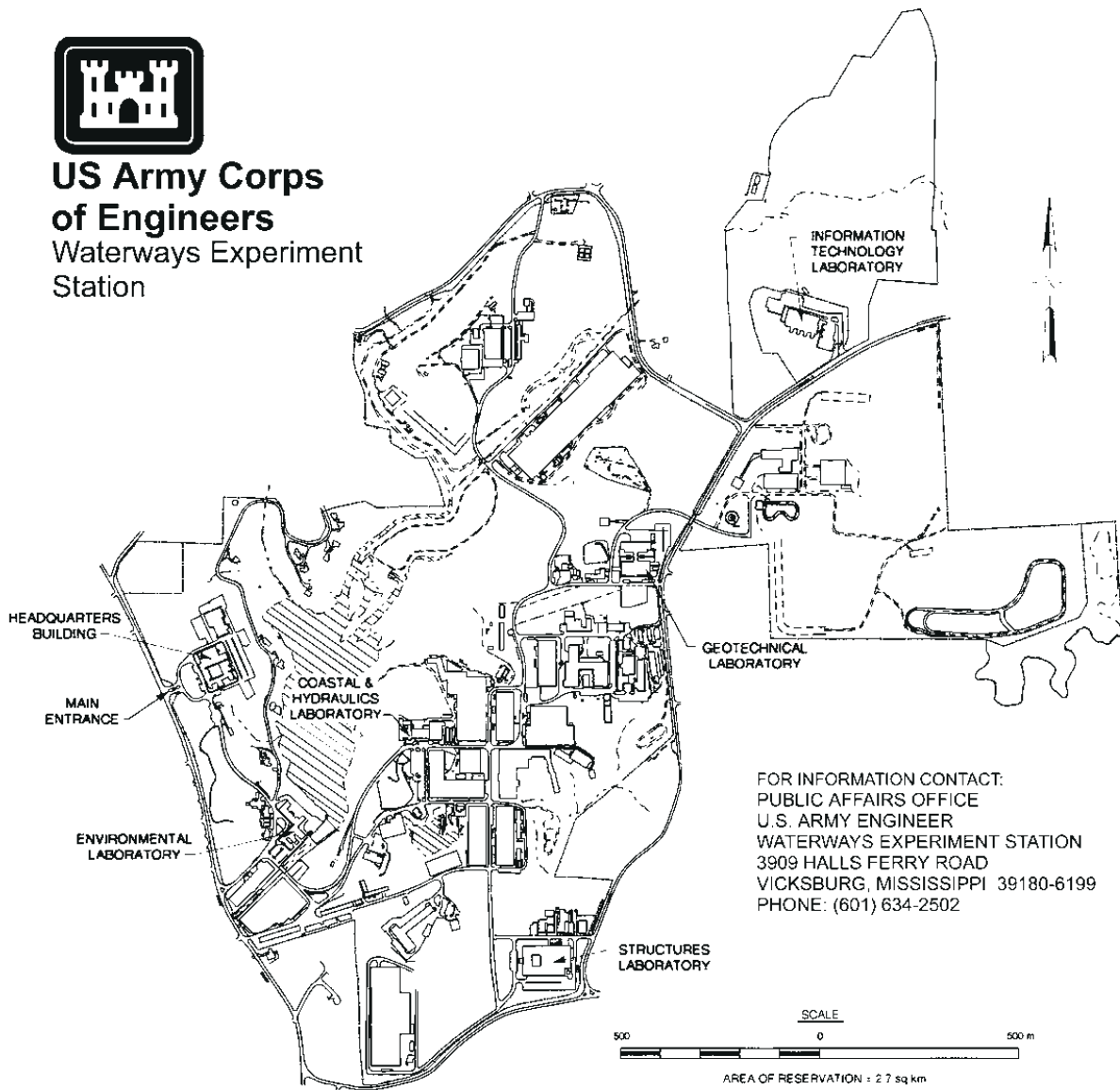

Waterways Experiment Station Cataloging-in-Publication Data

Guidance for subaqueous dredged material capping / by Michael R. Palermo ... [et al.] ; prepared for U.S. Army Corps of Engineers.

302 p. : ill. ; 28 cm. -- (Technical report ; DOER-1)

Includes bibliographic references.

1. Sediment capping -- Guidebooks. 2. Hazardous waste site remediation -- Guidebooks.
3. In situ remediation -- Guidebooks. 4. Contaminated sediments -- Guidebooks. I. Palermo, Michael R. II. United States. Army. Corps of Engineers. III. U.S. Army Engineer Waterways Experiment Station. IV. Dredging Operations and Environmental Research Program (U.S.) V. Series: Technical report (U.S. Army Engineer Waterways Experiment Station) ; DOER-1.

TA7 W34 no.DOER-1



Dredging: Contaminated Sediments

Guidance for Subaqueous Dredged Material Capping (TR DOER-1)

ISSUE: Potential for water column and benthic effects related to sediment contamination must be evaluated when considering open-water placement. Management options aimed at reducing the release of contaminants to the water column during placement and/or subsequent isolation of the material from benthic organisms may control potential contaminant effects. Subaqueous capping is the controlled, accurate placement of contaminated dredged material at an appropriately selected open-water placement site, followed by a covering (cap) of suitable isolating material. Although conventional placement equipment and techniques may be used for a capping project, these practices must be more precisely controlled in this application.

RESEARCH: The objective was to develop a comprehensive approach for evaluation of subaqueous capping projects, including these goals:

- Refine and adapt numerical models, laboratory testing procedures, and engineering design approaches for capping evaluations.
- Develop design requirements and a design sequence for capping.
- Document equipment and placement techniques for contaminated material and capping material placement.

- Define capping project site selection considerations.
- Develop guidelines for cap monitoring.

SUMMARY: The research resulted in technical guidance for evaluation of subaqueous dredged material capping. Guidance includes level-bottom capping, contained aquatic disposal, design requirements, a design sequence, site selection, equipment and placement techniques, geotechnical considerations, mixing and dispersion during placement, required capping sediment thickness, material spread and mounding during placement, cap stability, and monitoring plans. This guidance is applicable to dredged material capping projects in ocean waters as well as inland and near-coastal waters.

AVAILABILITY OF REPORT: The report is available in .pdf format on the World Wide Web at <http://www.wes.army.mil/el/dots> and through Interlibrary Loan Service from the U.S. Army Engineer Waterways Experiment Station (WES) Library, telephone (601) 634-2355. To purchase a copy of the report, call NTIS at (703) 487-4780.

About the Authors: Dr. Michael R. Palermo, Messrs. Tommy E. Myers, James E. Clausner, Gregory L. Williams, and Dr. Marian E. Rollings perform research at WES; contract support was provided by Dr. Robert E. Randall, Civil Engineering Department, Texas A&M University; and Dr. Thomas J. Fredette, the U.S. Army Engineer District, New England. **Point of Contact:** Dr. Palermo, Principal Investigator, telephone (601) 634-3753 or e-mail palermm@ex1.wes.army.mil.

Contents

Preface	xii
Conversion Factors, Non-SI to SI Units of Measurement	xiv
1—Introduction	1
Background	1
Purpose and Scope	2
Regulatory Setting	2
Overview and Description of the Capping Process	3
Organization of this Report	6
2—Design/Management Sequence for Capping	7
Design Philosophy for Capping	7
Dredged Material Capping Functions	7
Summary of Design Sequence for Capping	8
3—Characterization of Contaminated and Capping Sediments	16
Need for Sediment Characterization	16
Characterization of Contaminated Sediment	16
Selection of Capping Sediment	18
Characterization of Capping Sediment	18
Sampling and Testing Plans	19
4—Site Selection Considerations for Capping	20
General Considerations for Site Selection	20
Bathymetry	22
Currents	22
Average Water Depths	24
Operational Requirements	25
5—Equipment and Placement Techniques	26
Flow and Mounding Versus Dredging Method	26
Considerations for Contaminated Material Dredging and Placement	27
Considerations for Capping Material Placement	28
Equipment and Placement Techniques	29
Geotechnical Compatibility of Operations	38
Exposure Time Between Placement of Contaminated Material and Cap	39
Navigation and Positioning Controls	42

Placement Options, Restrictions, and Tolerances	45
Inspection and Compliance	49
6—Sediment Dispersion and Mound Development and Site Geometry During Placement	51
Sediment Dispersion During Placement	51
Evaluation of Spread and Mounding	53
Typical Contaminated Mound Geometry	54
Mound Geometry for Level-Bottom Capping	59
Geometry for CAD Projects	62
7—Dredged Material Cap Design	64
General Considerations	64
Required Cap Thickness	65
Required Design Cap Thickness and Area and Volume of Capping Material	76
Considerations for Intermediate Caps	78
8—Long-Term Cap Stability	79
Considerations in Long-Term Stability	79
Evaluation of Consolidation	80
Evaluation of Erosion Potential	85
9—Monitoring Considerations For Capping	98
Need for Monitoring	98
Design of Monitoring Programs and Plans	98
Monitoring Objectives	99
Components of the Monitoring Plan	100
Developing Testable Hypotheses	101
Construction Monitoring	102
Monitoring for Long-Term Effectiveness	102
Monitoring Techniques and Equipment	102
Designating Management Actions	105
10—Case Studies	106
Long Island Sound	106
New York Bight	111
Duwamish River Demonstration	117
One Tree Island Marina	117
Simpson Tacoma Kraft	119
Denny Way	120
Port of Los Angeles/Marina del Ray	120
Rotterdam Harbor	122
Hiroshima Bay	124
11—Summary and Recommendations	126
Summary	126
Recommendations	128
References	130
Appendix A: Glossary of Terms	A1
Appendix B: Model for Chemical Containment by a Cap	B1

Appendix C: Capping Effectiveness Tests	C1
Appendix D: Short-Term Fate (STFATE) of Dredged Material Model	D1
Appendix E: Multiple Dump Fate (MDFATE) of Dredged Material Model	E1
Appendix F: Long-Term Fate (LTFATE) of Dredged Material Model	F1
Appendix G: Procedures for Conducting Frequency-of-Erosion Studies	G1
Appendix H: Calculation of Required Cap Volumes for Level- Bottom Capping Projects	H1
Appendix I: Consolidation Testing	I1
SF 298	

List of Figures

Figure 1. Schematic illustrating LBC and CAD	4
Figure 2. Flowchart illustrating design sequence for dredged material capping projects	9
Figure 3. Conventional open-water placement for capping	30
Figure 4. Spreading technique for capping by barge movement	31
Figure 5. Pressure-hose washing method of placement	32
Figure 6. Spreader plate for hydraulic pipeline discharge	32
Figure 7. Spreader box or “sand box” for hydraulic pipeline discharge	33
Figure 8. Submerged diffuser system, including diffuser and discharge barge	34
Figure 9. Submerged diffuser	35
Figure 10. Hydraulic barge unloader and sand spreader barge	36
Figure 11. Conveyor unloading barge with tremie	37
Figure 12. Typical STFATE model results showing concentration above background of clay	53
Figure 13. Typical STFATE model results showing total volume of new material	53
Figure 14. Typical MDFATE model output showing differences between predisposal and postdisposal bathymetry	55
Figure 15. Typical MDFATE model output showing mound formation 1 to 3 years of disposal at Coos Bay	56
Figure 16. Typical mound geometry	57

Figure 17.	Original contaminated mound design for Port Newark/ Elizabeth project	61
Figure 18.	Disposal lanes used for triangular mound placement of contaminated material in Port Newark/Elizabeth project	61
Figure 19.	Schematics of cap thickness components and potential physical changes in cap thickness	65
Figure 20.	Flowchart illustrating sequence of evaluations for determining cap thickness	68
Figure 21.	Conceptual illustration of bioturbation activity versus sediment depth	69
Figure 22.	Idealized soil profile of mound and foundation soils . .	83
Figure 23.	Predicted final mound configuration at completion of consolidation	84
Figure 24.	Time rate of consolidation at center of mound	84
Figure 25.	Critical vertically averaged velocities for a plane bed .	87
Figure 26.	Initiation of motion for waves over a plane bed based on critical velocity	89
Figure 27.	Typical LTFATE model results showing long-term changes to mound geometry	91
Figure 28.	Frequency of vertical erosion from extratropical storms acting on a mound in Mud Dump site with a base depth of 73 ft and an 8-ft-high mound for a crest depth 65 ft .	94
Figure 29.	Idealized mound cross sections showing maximum and average vertical erosion and areas over which erosion volume is computed	96
Figure 30.	Central Long Island Sound disposal site	109
Figure 31.	Mud Dump site in New York Bight	112
Figure 32.	Port Newark/Elizabeth mound limits.	114
Figure 33.	Disposal lanes used for placing cap material in Port Newark/Elizabeth project	116
Figure 34.	Puget Sound capping projects	118
Figure 35.	One Tree Island Marina project	119
Figure 36.	Marina del Ray project plan showing location of berms and geotextile bags	123
Figure 37.	Rotterdam Harbor CAD project	124
Figure B1.	Idealized multilayer contaminant release rates showing individual and overall mass transfer coefficient definitions	B11
Figure B2.	Example calculations of contaminant flux through cap	B23
Figure C1.	Small-scale column test unit for capping effectiveness .	C3

Figure C2. Typical results for effect of sand cap on oxygen command	C8
Figure D1. Illustration of placement processes	D2
Figure E1. Typical MDFATE model output showing differences between predisposal and postdisposal bathymetry	E7
Figure E2. Typical MDFATE model output showing mound formation 1-3 years of disposal at Coos Bay	E8
Figure F1. Initial Sand Island mound contours	F11
Figure F2. Simulated Sand Island mound contours after 180 days	F11
Figure F3. Simulated Sand Island cross section 1,500 ft below centerline	F12
Figure G1. ADCIRC grid for computing surface elevations and currents	G3
Figure G2. Mud Dump disposal site location map	G7
Figure G3. Map showing WIS locations relative to the Mud Dump site	G9
Figure G4. Surge elevation and current hydrograph for Hurricane Gloria, without tides	G12
Figure G5. WIS wave height and period time series for 1977-78 extratropical storm season	G17
Figure G6. Sediment transport hydrograph for the 1977-78 storm season	G18
Figure G7. Simulated tropical storm-induced vertical erosion frequency curves for an 8-ft mound located at 83-ft depth, crest depth of 75 ft	G24
Figure G8. Mean value with error limits for frequency of vertical erosion from tropical storms for 8-ft mound located at 83-ft depth, crest depth of 75 ft	G25
Figure G9. Simulated extratropical storm-induced vertical erosion frequency curves for an 8-ft mound located at 83-ft depth, crest depth of 75 ft	G26
Figure G10. . . Mean value with error limits for frequency of vertical erosion from extratropical storms for 8-ft mound located at 83-ft depth, crest depth of 75 ft	G27
Figure G11. Idealized mound cross sections showing maximum and average vertical erosion and areas over which erosion volume is computed	G29
Figure H1. Geometry for a uniform cap thickness over a mound	H3
Figure H2. Geometry for a uniform cap with lesser thickness over apron	H4
Figure H3. Cap slope length calculation	H7
Figure I1. Standard oedometer testing device	I2

Figure I2.	Self-weight consolidation test device	I4
Figure I3.	Void ratio-effective stress relationship for contaminated dredged material	I6
Figure I4.	Void ratio-permeability relationship for contaminated dredged material	I6
Figure I5.	Void ratio-effective stress relationship for capping material	I7
Figure I6.	Void ratio-permeability relationship for capping material	I7
Figure I7.	Void ratio-effective stress relationship for foundation soil	I8
Figure I8.	Void ratio-permeability relationship for foundation soil	I8

List of Tables

Table 1.	Standard Geotechnical Laboratory Test Procedures	17
Table 2.	Flow Characteristics of Dredged Material Placed in Aquatic Sites	28
Table 3.	Compatibility of Capping and Contaminated Material Placement Options	40
Table 4.	Accuracy of Common Positioning Systems	43
Table 5.	Summary of Modeling Results for Capping Contaminated Sediments Using the Split-Hull Hopper Dredge Dodge Island and Hopper Barge Long Island	47
Table 6.	Episodic Erosion Thickness Estimates for Mud Dump Site for 0.4-mm Sand Caps	95
Table 7.	Sample Tiered Monitoring Program for a Capping Project	100
Table 8.	Summary of Selected Capping Projects	107
Table B1.	Physio-Chemical Properties of Site Parameters for Examples	B21
Table D1.	STFATE Model Input Parameters	D5
Table F1.	Example LTFATE Tidal Input Data File—TIDAL.DAT	F7
Table F2.	Example LTFATE Wave Input Data File—HPDSIM.OUT	F8
Table G1.	Tropical Events Impacting Mud Dump Site	G10
Table G2.	Tidal Constituents for DRP-WIS Station 304	G13
Table G3.	Summary of Storm Events by Day of Season/Maximum Transport Magnitude in $\text{ft}^3/\text{sec}/\text{ft-width} \times 10^{-4}$	G18

Table G4.	Mud Dump Mound Configurations	G19
Table G5.	Example LTFATE Input File	G20
Table G6.	Tropical Storm Input and Response Vectors for Mud Dump Site	G22
Table G7.	Extratropical Storm Input and Response Vectors for the Mud Dump Site	G22
Table G8.	Mean Value of Vertical Erosion/Frequency-of- Occurrence for Tropical Storms at Mud Dump Site	G24
Table G9.	Mean Value Erosion/Frequency-of-Occurrence for Extratropical Storms at Mud Dump Site	G26
Table G10.	Mean Maximum Vertical Erosion Frequency due to Tropical and Extratropical Storms Impacting 0.4-mm Sand-Capped Mounds	G30
Table H1.	Lengths Associated with Generic-Capped Mound in Figure H3	H6
Table H2.	Final Statistics of Cap Thickness from Port Newark/Elizabeth Project (March 1994)	H8
Table H3.	Contaminated and Cap Material Volumes and Mound Dimensions	H10

Preface

The work described in this report was authorized by Headquarters, U.S. Army Corps of Engineers (HQUSACE), and initiated as part of the “Management of Dredging Projects” Technical Area 5 of the Dredging Research Program (DRP). The work was performed under Work Unit 32489 for which Mr. James E. Clausner was Technical Manager. Mr. John G. Housley was the DRP Technical Monitor for the work. Mr. Robert H. Campbell, HQUSACE, was the Chief DRP Technical Monitor.

The work was completed as part of the Dredging Operations and Environmental Research (DOER) program “Contaminated Sediment Characterization and Management” Focus Area, managed by Dr. Michael R. Palermo. DOER Program Monitors are Messrs. Barry Holliday, Joseph Wilson, John Bianco, and Charles Chestnutt, HQUSACE.

The work was performed by Dr. Palermo, Principal Investigator and Mr. Tommy E. Myers, U.S. Army Engineer Waterways Experiment Station (WES) Environmental Laboratory (EL); Dr. Marian P. Rollings, WES Geotechnical Laboratory (GL); Messrs. Clausner and Gregory L. Williams, WES Coastal and Hydraulics Laboratory (CHL); Dr. Thomas J. Fredette, U.S. Army Engineer District, New England; and Dr. Robert E. Randall, Texas A&M University. The contributions of Drs. Paul R. Schroeder, Doug Clarke, and Joe Gailani, WES, and Danny D. Reible, Louisiana State University, who authored Appendix B, are gratefully acknowledged.

The study was conducted by or under the following WES supervision:

EL—Dr. Palermo, Special Projects Group, Environmental Engineering Division (EED); and Mr. Myers, Environmental Restoration Branch (ERB), EED. Additional supervision was provided by Mr. Daniel E. Averett, Chief, ERB; Mr. Norman R. Francingues, Jr., Chief, EED; Dr. Raymond L. Montgomery (retired), former Chief, EED; Dr. John W. Keeley, Assistant Director, EL; and Dr. John Harrison, Director, EL.

CHL—Messrs. Clausner and Williams, Coastal Evaluation and Design Branch (CEDB), Coastal Sediments and Engineering Division (CSED). Additional supervision was provided by Ms. Joan Pope, Chief, CEDB; Mr. Thomas W. Richardson, Chief, CSED; Messrs. Charles C. Calhoun, Jr., and Richard A. Sager, Assistant Directors, CHL; and Dr. James R. Houston, Director, CHL.

GL—Dr. Rollings, Materials Analysis Branch (MAB), Airfields and Pavements Division (APD). Additional supervision was provided by Mr. Timothy W. Vollor, Chief, MAB; Dr. David Pittman, Chief, APD; and Dr. William F. Marcuson III, Director, GL.

Mr. E. Clark McNair, Jr., CHL, was the DRP Program Manager, and is the DOER Operational Program Manager. Dr. Robert M. Engler, EL, is the DOER Executive Program Manager.

Technical review of this report was provided by a joint U.S. Army Corps of Engineers (USACE)/U.S. Environmental Protection Agency (EPA) workgroup comprised of individuals from Headquarters, field offices, and research laboratories of both agencies with scientific and/or programmatic experience related to dredged material disposal management.

Members of the workgroup are as follows:

Joe Wilson	USACE Headquarters	John Lishman	EPA Headquarters
Dave Mathis	USACE Headquarters	Bev Baker	EPA Headquarters
Jan Miller	USACE North Central District	Dave Redford	EPA Headquarters
Tom Fredette	USACE New England District	Tom Chase	EPA Headquarters
John Tavoraro	USACE New York District	Kimberlee Keckler	EPA Region I
Alex Sumeri	USACE Seattle District	Dan Forger	EPA Region II
Douglas Pirie	USACE South Pacific Division	Andrey Massa	EPA Region II
Mike Palermo	USACE WES	Bill Muir	EPA Region III
Jim Clausner	USACE WES	Robert Howard	EPA Region IV
Tom Myers	USACE WES	Phil Murphy	EPA Region IV
Clark McNair	USACE WES	Steve Johnson	EPA Region V
Robert Engler	USACE WES	Suzie McKinney	EPA Region VI
		Norm Sears	EPA Region VI
		Brian Ross	EPA Region IX
		Justine Barton	EPA Region X

At the time of publication of this report, Director of WES was Dr. Robert W. Whalin. Commander was COL Robin R. Cababa, EN.

This report should be cited as follows:

Palermo, M. R., Clausner, J. E., Rollings, M. P., Williams, G. L., Myers, T. E., Fredette, T. J., and Randall, R. E. (1998). "Guidance for subaqueous dredged material capping," Technical Report DOER-1, U.S. Army Engineer Waterways Experiment Station, Vicksburg, MS.

Conversion Factors, Non-SI to SI Units of Measurement

Non-Si units of measurement used in this report can be converted to SI units as follows:

Multiply	By	To Obtain
acres	4,046.873	square meters
cubic yards	0.7645549	cubic meters
feet	0.3048	meters
inches	25.4	millimeters
miles (U.S. statute)	1.609347	kilometers

1 Introduction

Background

The U.S. Army Corps of Engineers (USACE) and the U.S. Environmental Protection Agency (EPA) have statutory responsibilities with regard to the management of dredged material placement in both ocean and inland and nearshore waters. When dredged materials proposed for open-water placement are found to require isolation from the benthic environment, capping may be appropriate for consideration as a management action. The report herein is intended to provide technical guidance for evaluation of capping projects.

This is one of a series of guidance reports pertaining to dredged material management. This series includes a document entitled “Evaluating Environmental Effects of Dredged Material Management Alternatives - A Technical Framework” (Framework Document - USACE/EPA 1992). The Framework Document articulates those factors to be considered in identifying the environmental effects of dredged material management alternatives on a continuum of discharge sites from uplands to the oceans (management alternatives include open-water, confined, and beneficial-use situations) that meet the substantive and procedural requirements of the National Environmental Policy Act (NEPA), The Federal Water Pollution Control Act of 1972, Public Law 92-500, as amended by the Clean Water Act of 1977 (CWA), and the Marine Protection, Research, and Sanctuaries Act (MPRSA). Application of the technical guidance in this report will allow for consistency in decision making with respect to capping within the Technical Framework.

Potential for water column and benthic effects related to sediment contamination must be evaluated when considering open-water placement of dredged material. Management options aimed at reducing the release of contaminants to the water column during placement and/or subsequent isolation of the material from benthic organisms may be considered to control potential contaminant effects. Such options include operational modifications, use of subaqueous discharge points, diffusers, subaqueous lateral confinement of material, or capping of contaminated material with suitable material (Francingues et al. 1985; USACE/EPA 1992).

Subaqueous dredged material capping is the controlled, accurate placement of contaminated dredged material at an appropriately selected open-water placement site, followed by a covering or cap of suitable isolating

material (a glossary of terms used in this report is found in Appendix A). Capping of contaminated dredged material in open-water sites began in the late 1970s, and a number of capping operations under a variety of placement conditions have been accomplished. Conventional placement equipment and techniques are frequently used for a capping project, but these practices must be controlled more precisely than for conventional placement.

Purpose and Scope

This report provides guidance for evaluation of subaqueous dredged material capping projects. Design requirements, a design sequence, site selection, equipment and placement techniques, geotechnical considerations, mixing and dispersion during placement, required capping sediment thickness, material spread and mounding during placement, cap stability, and monitoring are included. From a technical perspective, this guidance is applicable to dredged material capping projects in ocean waters as well as inland and near-coastal waters.

The technical guidance in this report is intended for use by USACE and EPA personnel, State regulatory personnel, as well as dredging permit applicants and others (e.g., scientists, engineers, managers, and other involved or concerned individuals).

Regulatory Setting

Capping involves placement of dredged material in either ocean waters or inland and near-coastal waters (waters of the United States). The primary Federal environmental statute governing transportation of dredged material to the ocean for purpose of placement is the MPRSA, also called the Ocean Dumping Act. The primary Federal environmental statute governing the discharge of dredged and/or fill material into waters of the United States (inland of the baseline to the territorial sea) is the Federal Water Pollution Control Act Amendments of 1972, also called the CWA. All proposed dredged material placement activities regulated by the MPRSA and CWA must also comply with the applicable requirements of the NEPA and its implementing regulations. In addition to MPRSA, CWA, and NEPA, there are a number of other Federal laws, Executive Orders, etc., that must be considered in the evaluation of dredging projects.

The London Convention (Convention on the Prevention of Marine Pollution by Dumping of Waste and Other Matter, December 29, 1972 (26 UST 2403:TIAS 8165)), to which the United States is a signatory, is an international treaty that deals with marine-waste placement, with jurisdiction that includes all waters seaward of the baseline of the territorial sea. The ocean-dumping criteria developed under MPRSA are required to “apply the standards and criteria binding upon the United States under the

Convention, including its Annexes,” to the extent this would not result in relaxation of MPRSA requirements.

In evaluating proposed ocean placement activities, the USACE is required to apply criteria developed by the EPA relating to the effects of the proposed placement activity. The MPRSA criteria are given in 40 CFR 220-227. In evaluating proposed placement activities in inland or coastal waters, the USACE is required to apply guidelines given by Section 404 of the CWA to ensure that such proposed discharge will not result in unacceptable adverse environmental impacts to waters of the United States. The guidelines are given in 40 CFR 230. A tiered approach to sediment testing and assessments is described in detail in the dredged material testing manuals for MPRSA and CWA (EPA/USACE 1991; EPA/USACE 1998).

This report addresses technical and scientific issues associated with capping and does not address the various regulatory requirements of the CWA and MPRSA. Whether or not a particular project involving capping satisfies the relevant regulatory criteria can only be determined by applying the relevant requirements of the regulation and consulting, as necessary, with legal counsel.

Overview and Description of the Capping Process

Capping defined

For purposes of this report, the term “contaminated” refers to material for which isolation from the benthic environment is appropriate because of potential contaminant effects, while the term “clean” refers to material found to be acceptable for open-water placement. Capping is the controlled accurate placement of contaminated material at an open-water placement site, followed by a covering or cap of clean isolating material. For most navigation dredging projects, capping alternatives involving armor stone layers or other nonsediment materials for capping would not normally be considered.

Level-bottom capping (LBC) is defined as the placement of a contaminated material in a mounded configuration and the subsequent covering of the mound with clean sediment. Contained aquatic disposal (CAD) is similar to LBC but with the additional provision of some form of lateral confinement (e.g., placement in natural-bottom depressions, constructed subaqueous pits, or behind subaqueous berms) to minimize spread of the materials on the bottom. An illustration of LBC and CAD is shown in Figure 1.

The objective of LBC is to place a discrete mound of contaminated material on an existing flat or gently sloping natural bottom. A cap is then applied over the mound by one of several techniques, but usually in a series of placement sequences to ensure adequate coverage. CAD is generally used

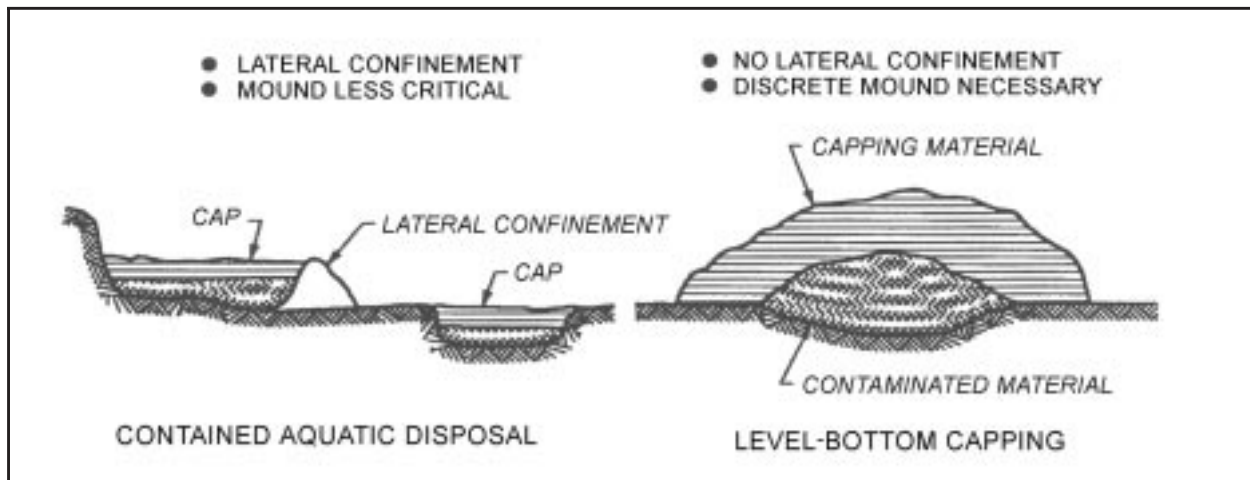

Figure 1. Schematic illustrating LBC and CAD

where the mechanical properties of the contaminated material and/or bottom conditions (e.g., slopes) require positive lateral control measures during placement. Use of CAD can also reduce the required quantity of cap material and thus the costs. Options might include the use of an existing natural or excavated depression, preexcavation of a placement pit, or construction of one or more submerged dikes for confinement (Truitt 1987a).

Dredged material capping versus in situ capping for remediation

Capping is also a potential alternative for remediation of contaminated sediments in place or in situ. However, a clear distinction should be made between navigation dredged material capping and capping in the remediation context. For dredged material capping associated with navigation projects, the sediment of concern would typically require capping because it may exhibit potential for toxicity or significant bioaccumulation in benthic organisms. Often these sediments are only marginally contaminated in comparison with other sediments in the area. The objective of capping in this context is to effectively eliminate direct exposure of benthic organisms to the contaminated sediments and thus virtually eliminate potential benthic toxicity or bioaccumulation.

For in situ capping in the remediation context, the sediments of concern are sufficiently contaminated to warrant some sort of cleanup action. The objective of capping in the remediation context may involve objectives over and above isolation of the sediment from the benthic environment. Guidance for in situ capping for sediment remediation is presented in Palermo et al. (1996).

Design issues for capping

Capping is a contaminant control measure to prevent impacts. However, dredged material capping requires initial placement of a contaminated

material at an open-water site. Several issues, therefore, must be carefully considered within the context of a capping project design. These include the following:

- a. *Potential water column impacts during placement.* Assessment should consider evaluation of potential release of contaminants to the water column, evaluation of potential water column toxicity, and evaluation of initial mixing. Elutriate test procedures for water quality, water column bioassay tests, and computer models for dispersion and mixing are available to address these requirements. The mass loss of contaminants during placement (fraction dispersed offsite and remaining uncapped) may also be predicted using these same tests and models.
- b. *Efficacy of cap placement.* Assessment should consider available capping materials, methods for dredging and placement of both contaminated material and cap material, compatibility of site conditions, material physical properties, and dredging and placement techniques. Guidance on selection of appropriate methods, compatibility with site conditions and material properties, and computer models for predicting mound development and spreading behavior are available.
- c. *Long-term cap integrity.* Assessment should consider the physical isolation of contaminants, potential bioturbation of the cap by benthos, consolidation of the sediments, long-term contaminant flux through the cap due to advection/diffusion, and potential for physical disturbance or erosion of the cap by currents, waves, and other forces such as anchors, ship traffic, ice, etc. Test procedures for contaminant isolation and consolidation and computer models for evaluation of long-term contaminant flux, consolidation, and resistance to erosion are available.

Each of these issues must be appropriately addressed by the project design.

Viability of capping as an alternative

Capping is only one of several alternatives that may be considered for dredged material that is excessively contaminated and would need isolation from the benthic environment if proposed for open-water placement. If the issues described above can be satisfactorily addressed in the project design for the specific set of sediment, site, and operational conditions under consideration, capping is a technically viable option.

Capping is not a technically viable option for a specific set of sediment, site, and operational conditions described below:

- a. Contaminant release and dispersion behavior of the contaminated material (even with consideration of controls) results in unacceptable water column impacts during placement.

- b.* Spreading or mounding behavior of the contaminated material or cap material (even with consideration of controls) indicates that the required cap cannot be effectively placed.
- c.* Energy conditions or operational conditions at the site are such that the required cap thickness cannot be effectively maintained in the long term.
- d.* Institutional constraints do not provide the ability to commit to the long-term monitoring and management requirements.

Under such circumstances, other options for placement of the contaminated sediments must be considered.

Organization of this Report

The main body of this report describes specific procedures for all aspects of capping-project evaluation and design. A number of appendixes are also included that provide detailed information on specific testing procedures, predictive models, etc. Chapter 2 describes the recommended sequence of design activities, and specific design steps are organized into flowcharts as necessary.

2 Design/Management Sequence for Capping

Design Philosophy for Capping

Capping is not a form of unrestricted open-water placement. A capping operation is an engineered project with carefully considered design, construction, monitoring, and maintenance to ensure that the design is adequate. A successful capping project requires a team approach with input from engineers, biologists/ecologists, chemists, and dredging operations experts. The basic criterion for a successful capping operation is that the cap thickness required to isolate the contaminated material from the environment be successfully placed and maintained.

Dredged Material Capping Functions

A dredged material cap can serve three primary functions:

- a.* Physical isolation of the contaminated dredged material from the benthic environment.
- b.* Stabilization of contaminated material, preventing resuspension and transport to other sites.
- c.* Reduction of the flux of dissolved contaminants into the cap and overlying water column.

If a dredged material is unsuitable for open-water placement due to potential contaminant impacts, physical isolation of the dredged material from the benthic environment and from resuspension and transport offsite would normally be primary functions of a dredged material cap. Control of contaminant flux may be a desired function, depending on the sediment characteristics, site conditions, and other factors.

Summary of Design Sequence for Capping

The flowchart shown in Figure 2 illustrates the major design requirements for a capping project and the sequence in which the design requirements should be considered. There is a strong interdependence between all components of design for a capping project. For example, the initial consideration of a capping site and placement techniques for both the contaminated and capping materials strongly influence all subsequent evaluations, and these initial choices must also be compatible for a successful project (Shields and Montgomery 1984). Each step in the process must be clearly identified and documented before a decision can be made to proceed.

When an efficient sequence of activities for the design of a capping project is followed, unnecessary data collection and evaluations can be avoided. General descriptions of the various design requirements are given below corresponding to the recommended design sequence (Palermo 1991a). Each block in the flowchart (Figure 2) is numbered, and a description of each block is referenced by the number in parentheses in this chapter. More detailed guidance on various aspects of the design is provided in Chapters 3 through 9 and Appendixes B through I of this report. Chapter 10 describes capping case studies and field experience for major capping projects under a range of project conditions. Chapter 11 summarizes the guidance provided in this document.

Gather project data and select design criteria (1)

The first step in any capping project design is to gather and evaluate the existing project data, which normally include surveys of the dredging area, physical and chemical characteristics of the contaminated sediment, equipment used for dredging and placement, and characteristics of potential placement sites (i.e., area erosion trends, wind-wave resuspension, wave-current interaction effects). Since capping is under consideration, data on the suitability of the material to be dredged for open-water placement may exist. These data may include results of physical, chemical, and biological tests required under Section 404 of the CWA or Section 103 of the MPRSA. Data on potential placement sites may vary. Bathymetry, currents, storm frequencies, wave heights, and bottom-sediment characterization are normally available for open-water sites under consideration.

Once the existing data have been gathered, the design functions of the cap can be determined and design criteria selected. Specific design criteria will depend on the selected design functions for the cap, i.e., physical isolation, stabilization, or reduction of contaminant flux. Design criteria may be developed in a number of ways: providing cap thickness for isolation of benthic organisms to a given bioturbation depth; reducing contaminant flux rates to achieve specific sediment, pore water, or water column target concentrations; specific storm or flood flow return periods for cap stability; limits on mound elevation to meet navigation or erosion constraints; placement of all material within given site boundaries, etc. Such criteria should be defined prior to starting design of the capping project. Three main aspects of capping design must be examined: aspects related to

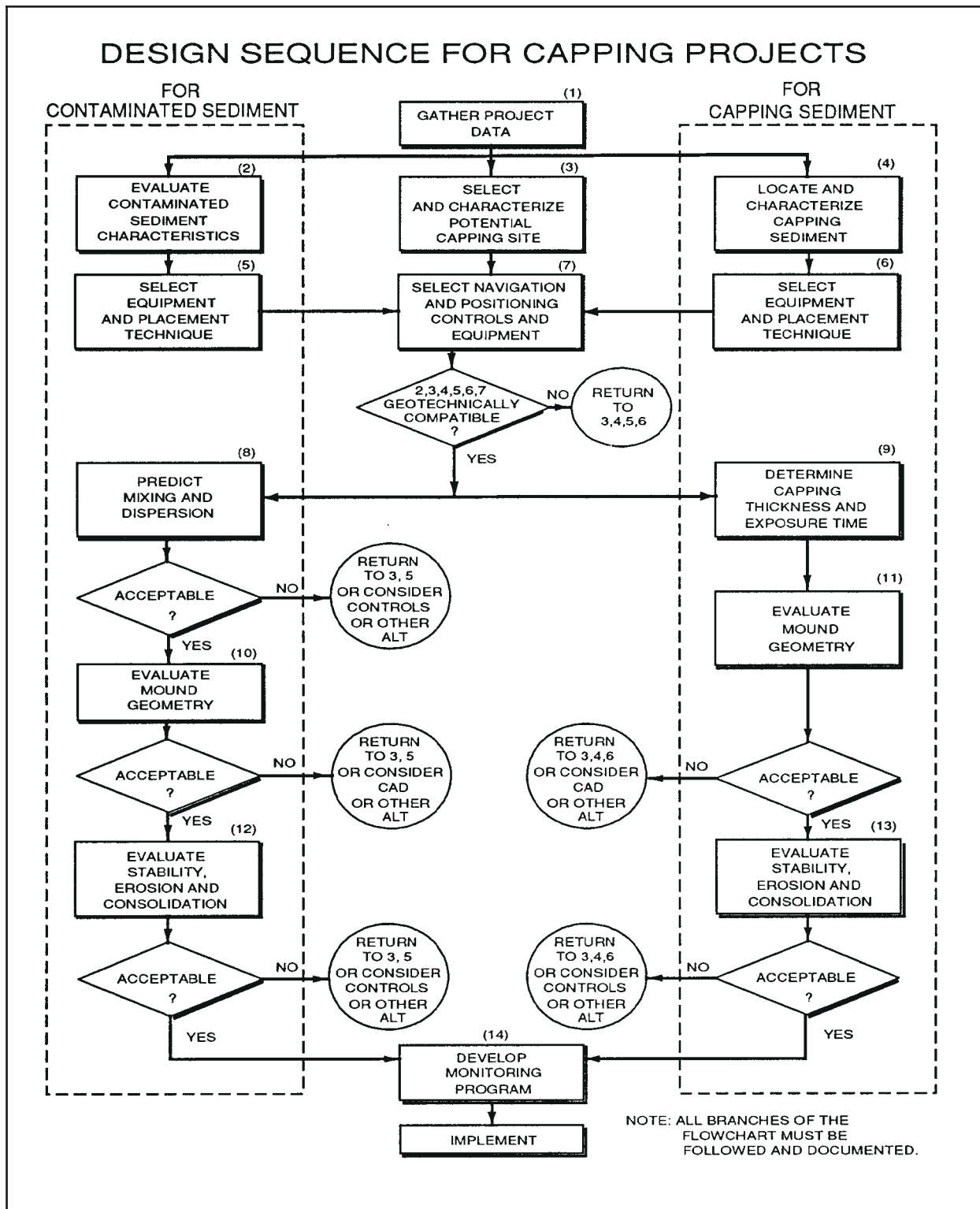

Figure 2. Flowchart illustrating design sequence for dredged material capping projects (after Palermo 1991a)

characterization and placement of the contaminated material, aspects related to the characterization and placement of the capping material, and aspects related to the capping site under consideration. Each of these aspects must be initially examined in a parallel fashion (see Blocks 2, 3, and 4 of Figure 2). Further, the interrelationship and compatibility of these three aspects of the design are critical.

Characterize contaminated sediment (2)

The contaminated sediment must be characterized from physical, chemical, and biological standpoints. Physical characteristics are of importance in determining the behavior of the material during and following placement at a capping site. In situ volume (to be dredged), in situ density (or water content), shear strength, compressibility, and grain-size distribution are needed for evaluations of dispersion and spread during placement, mounding characteristics, consolidation, and long-term stability and resistance to erosion. These data should be developed using standard techniques.

Some chemical and biological characterization of the contaminated sediment is normally performed as a part of the overall evaluation for suitability for open-water placement. Guidance on characterization of contaminated sediments is found in Chapter 3.

Select a potential capping site (3)

The selection of a potential site for capping is subject to the same constraints and tradeoffs as any other open-water placement site. The major considerations in site selection include bathymetry, bottom slopes, currents, water depths, water column density stratification, erosion/accretion trends, proximity to navigation channels and anchorages, bottom-sediment characteristics, and operational requirements such as distance to the site and wave climate. However, in addition to normal considerations, the capping site should ideally be in a relatively low-energy environment with little potential for erosion or disturbance of the cap. While capping at a low-energy site is desirable, such sites are not always available. Higher energy sites can be considered for dredged material capping, but a detailed study of erosion potential is required; increases in cap thickness to account for potential erosion or use of a coarser grain-size material may be required.

Consideration should be given to the following factors during selection of a potential capping site. Bathymetry forming a natural depression will tend to confine the material, resulting in a CAD project. Placement of material on steep bottom slopes should generally be avoided for a capping project. Water column currents affect the degree of dispersion during placement and the location of the mound with respect to the point of discharge. Of more importance are the bottom currents, which could potentially cause resuspension and erosion of the mound and cap. The effects of storm-induced waves on bottom-current velocities must be considered. For some sites, other processes such as prop wash may need to be considered. The deeper the water is at the site, the greater the potential is for

water entrainment and dispersion during placement. However, deeper water depths also generally provide more stable conditions on the bottom with less potential for erosion. Numerical models for prediction of water column behavior, mound development, and long-term stability against erosion may be used in evaluating site conditions. Guidance on site selection for capping is found in Chapter 4.

Select and characterize capping sediment (4)

The cap sediment used in a project should be carefully selected. However, for economic reasons, a capping sediment is usually taken from an area that also requires dredging or is considered advanced maintenance dredging. If this is the case, there may be a choice between projects. Scheduling of the dredging is also an important consideration. In other cases, removal of bottom sediments from areas adjacent to the capping site may be considered.

The capping sediment is characterized as described above for the contaminated sediment. However, the capping sediment must be one that is suitable for open-water placement (i.e., a clean sediment). The evaluation of a potential capping sediment for open-water placement acceptability must be accomplished using appropriate techniques under either CWA or MPRSA. Physical characteristics of the capping sediment are also of particular interest in capping design. Density (or water content), grain-size distribution, and cohesiveness of the capping sediment must be evaluated. Selection of the capping sediment should be carefully considered because the capping material must be compatible with the contaminated sediment and this compatibility is related to dredging and placement equipment and techniques. Previous studies have shown that both fine-grained materials and sandy materials can be effective capping materials. Guidance on selecting and characterizing capping sediment is found in Chapter 3.

Select equipment and placement technique for contaminated sediment (5)

A variety of equipment types and placement techniques have been used for capping projects. The important factors in the placement of contaminated material are reducing water column dispersion and bottom spread to the greatest possible extent. This minimizes the release of contaminants during placement and provides for easier capping. For LBC the dredging equipment and placement technique for contaminated sediment must provide a tight, compact mound. This is most easily accomplished with mechanical dredging and barge release (point dumping). If CAD is under consideration, hydraulic placement of the contaminated material may be acceptable.

Specialized equipment and placement techniques can also be considered to increase control during placement and reduce potential dispersion and spread of contaminated material. These might include use of submerged diffusers or submerged discharge points for hydraulic pipeline placement, hopper dredge pump-down with diffuser, or gravity-fed tremie

for mechanical or hydraulic placement or use of geosynthetic fabric containers. Guidance for equipment and placement techniques is found in Chapter 5.

Select equipment and placement technique for capping sediment (6)

The major design requirement in the selection of equipment and placement of the cap is the need for controlled, accurate placement and the resulting density and rate of application of capping material. In general, the cap material should be placed so that it accumulates in a layer covering the contaminated material. The use of equipment or placement rates that might result in the capping material displacing or mixing with the previously placed contaminated material must be avoided. Placement of capping material at equal or lesser density than the contaminated material or use of placement methods to spread thin layers to gradually build up the cap thickness usually meets this requirement.

Specialized equipment and placement techniques can be considered to increase control of capping material placement. The movement of submerged diffusers, energy dissipaters, submerged discharge points, or tremies can be controlled to spread capping material over an area to a required thickness. Incremental opening of split-hull or multicompartiment barges along with controlled movement of the barges during surface release, direct pump-out through pipes, and direct washing by hoses have been used for placing mechanically dredged sandy capping material. Energy dissipaters for hydraulic placement of capping materials have been successfully used. Guidance on selection of equipment and placement techniques is found in Chapter 5.

Select navigation and positioning equipment and controls (7)

Placement of both the contaminated and capping material must be carefully controlled, regardless of the equipment and placement technique selected. Electronic positioning systems, taut-moored buoys, mooring barges, various acoustical positioning devices, and computer-assisted, real-time helmsman's aids should be considered in selecting the equipment and placement technique. Guidance on selection of navigation and positioning equipment and controls is found in Chapter 5.

Evaluate compatibility of site, materials, and equipment

At this point in the design, the contaminated material has been characterized; a site has been identified and characterized; a capping sediment has been selected and characterized; equipment and placement techniques have been selected for both materials and navigation; and positioning needs have been addressed. These essential components of the design (Blocks 2, 3, 4, 5, 6, and 7 in Figure 2) must now be examined as a whole, with compatibility in mind, to evaluate the efficacy of cap placement for the sediments, site conditions, equipment availability and capabilities under

consideration, and cost. The primary concern with compatibility relates to geotechnical considerations and the ability of the contaminated material to support the cap, considering the material characteristics and dredging and placement techniques.

Guidance on the compatibility of various dredging and placement techniques for differing material types has been developed based on field experience and knowledge of the resulting dispersion and spreading behavior and physical stability of the materials. If the various site, sediment, and selected equipment components are compatible, additional and more detailed design requirements can be addressed. If there is a lack of compatibility at this point, a different capping site (3), a different capping sediment (4), or different dredging and placement equipment and techniques (5,6) must be considered. A close examination of the project design components at this decision point is essential before performing the more detailed and costly evaluations that come later in the design process. Guidance on evaluation of sediment, site, and equipment compatibility is found in Chapter 5.

Predict water column mixing and dispersion effects of contaminated sediment during placement (8)

If water column effects during placement of the contaminated material are of concern, an evaluation of the suitability of the material from the standpoint of water column effects must be performed. This evaluation involves the comparison of predicted water column contaminant concentrations with water quality criteria and predicted water column dredged material concentrations with bioassay test results. Use of available mathematical models and/or case study field-monitoring results to predict the water column dispersion and concentrations is an integral part of such evaluations. In addition, the prediction indicates what portion of the contaminated material is released during placement and thus is not capped. Evaluation of initial deposition and spread of material is used in determining the mounding characteristics for the entire contaminated material volume to be placed. If water column release is unacceptable, control measures need to be considered to reduce the potential for water column effects, or other dredging equipment and placement techniques (5) or use of another capping site (3) must be considered. Guidance on prediction of water column effects during placement is found in Chapter 6 and Appendix D.

Determine cap design (9)

The cap must be designed to adequately isolate the contaminated material from the aquatic environment and achieve the intended cap functions. The composition and dimensions (thickness) of the components of a cap can be referred to as the cap design. The composition of caps for dredged material projects is typically a single layer of clean sediments because relatively large volumes of cap material are involved; clean sediments from other dredging projects are often available as cap materials; and dredged material capping sites with low potential for erosion can be

selected. Guidance on dredged material cap design therefore focuses on the thickness of the cap as the major design criterion.

The determination of the required cap thickness is dependent on the physical and chemical properties of the contaminated and capping sediments, the potential for bioturbation of the cap by aquatic organisms, the potential for consolidation and the resultant expulsion of pore water from the contaminated sediment, and the potential for consolidation and erosion of the cap material. The minimum required cap thickness is considered the thickness required for physical isolation plus any thickness needed for control of contaminant flux. The integrity of the cap from the standpoint of physical changes in cap thickness and long-term migration of contaminants through the cap should also be considered. The potential for a physical reduction in cap thickness due to the effects of consolidation and erosion (12,13) can be evaluated once the overall size and configuration of the capped mound is determined. A precise calculation of the erosion thickness component requires consideration of mound shape, mound height, and water depth. Since these parameters also depend on the total capping thickness, some iterative calculations may be required. The design cap thickness is the required cap thickness for isolation plus that required for consolidation and erosion and operational considerations. Guidance on cap design is found in Chapter 7, and details on specific testing and evaluation procedures and models to support cap design are found in Chapters 6 and 8 and Appendixes B, C, E, F, G, and H.

Evaluate spread, mounding and site geometry (10,11)

For LBC sites, the mound geometry, including contaminated material mound and cap, will influence the design of the cap and volume of capping material required. The smaller the footprint of the contaminated material as placed, the less volume of capping material is required to achieve a given cap thickness. The spread and development of the contaminated material mound is dependent on the physical characteristics of the material (grain size and cohesion) and the placement technique used (hydraulic placement results in greater spread than mechanical placement). Assuming that the material from multiple barge loads or pipeline can be accurately placed at a single point, mound side slope and the total volume placed dictate the mound spread. The formation of a thin layer or apron surrounding the central mound must also be considered in defining the footprint to be capped for LBC.

For CAD projects, in which lateral containment prevents spreading and apron formation, the footprint will be determined by the site geometry. However, the volume occupied by the sediments will govern the capacity of the CAD site and must be considered as a factor in site design. If the mound geometry or CAD site geometry is unacceptable, an alternative site (3), alternative capping sediment (4), or alternative placement techniques (5,6) can be considered. Guidance on mound spread and development and site geometry is found in Chapter 6 and Appendixes E and H.

Evaluate stability, erosion, and consolidation (12,13)

The deposit of contaminated dredged material must also be stable against excessive erosion and resuspension of material before placement of the cap. The cap material must be stable against long-term erosion for the required cap thickness to be maintained. The potential for resuspension and erosion is dependent on bottom current velocity, potential for wave-induced currents, sediment particle size, and sediment cohesion. Site selection criteria as described above normally results in a site with low bottom-current velocity and little potential for erosion. However, if the material is hydraulically placed (as for a CAD site) or a site with higher energy potential is considered, a thorough analysis of the potential for resuspension and erosion must be performed, to include frequency considerations. Conventional methods for analysis of sediment transport can be used to evaluate erosion potential. These methods can range from simple analytical techniques to numerical modeling.

Consolidation of contaminated material needs to be examined for its effect on LBC mound slopes and volumes and on the volume occupied within CAD sites. In general, consolidation of the contaminated dredged material will result in more stable conditions. The same is true for consolidation of the cap material. However, consolidation of the cap results in a reduced cap thickness. Therefore, the potential for cap consolidation must be accounted for in the overall design of the cap thickness.

If the potential for erosion and consolidation of either the contaminated material or cap is unacceptable, an alternative site (3), alternative capping sediment (4), or alternative placement techniques (5,6) can be considered. Guidance on evaluating long-term cap stability is found in Chapter 8 and Appendixes F, G, and I.

Develop a monitoring program (14)

A monitoring program or site monitoring plan is required as a part of any capping project design. The main objectives of monitoring normally are to ensure that the contaminated sediment is placed as intended and with acceptably low levels of contaminant release, the cap is placed as intended and the required capping thickness is maintained, and the cap is effective in isolating the contaminated material from the environment. Monitoring plans for capping projects need to include a more intensive effort during and shortly after placement operations and immediately after unusual events (e.g., severe storms), with a declining level of effort in future years if no adverse effects are detected. Physical, chemical, and biological elements may be included in a monitoring plan. In all cases, the objectives of the monitoring effort and any remedial actions to be considered as a result of the monitoring must be clearly defined as a part of the overall project design. Guidance on monitoring considerations for capping is found in Chapter 9. Case studies of capping projects including conclusions drawn from field monitoring efforts are described in Chapter 10.

3 Characterization of Contaminated and Capping Sediments

Need for Sediment Characterization

Characterization of both the contaminated sediment and potential capping sediments is necessary for evaluation of the environmental acceptability of sediments for open-water placement and to determine physical and engineering properties necessary for prediction of both short- and long-term behavior of the sediments. Some characterization data may have been obtained as a part of a more general investigation of disposal alternatives prior to consideration of capping.

Characterization of Contaminated Sediment

The contaminated sediments to be capped are likely to have been characterized to some degree prior to consideration of capping. In any event, the contaminated sediment must be characterized from a physical, chemical, and biological standpoint.

Physical characterization

The physical characteristics of the contaminated sediment are of importance in predicting the behavior of the material during and following placement at a capping site. Physical characterization is needed for evaluations of dispersion and spread during placement, mounding characteristics, and long-term stability and resistance to erosion.

Physical tests and evaluations on sediment should include visual classification, natural (in situ) water content/solids concentration/bulk density, plasticity indices (Atterberg limits), organic content, grain-size distribution, specific gravity, and Unified Soil classification. Standard geotechnical laboratory test procedures, such as those of the American Society for Testing and Materials (ASTM), the American Association of State Highway

Transportation Officials (AASHTO), or the USACE, should be used for each test. Table 1 gives the standard ASTM and USACE designations for the needed tests and also cross-references these procedures to those of several other organizations that have standardized test methods.

Table 1 Standard Geotechnical Laboratory Test Procedures					
Test	Designation				Comments
	ASTM	AASHTO	COE ¹	DoD ^{2,3}	
Soils					
Water content	D 2216	T265	I	Method 105, 2-VII	
Grain size	D 422	T88	V	2-III, 2-V, 2-VI	
Atterberg limits	D 4318	T89 T90	III	Method 103, 2-VIII	
Classification	D 2487		III		
Specific gravity	D 854	T100	IV	2-IV	
Organic content	D 2974				Use Method C
Consolidation ⁴	D 2435	T216	VIII		
Permeability ⁵	D 2434	T215	VII		
Shear tests	D 2573				Field test
¹ Department of the Army Laboratory Soils Manual EM 1110-2-1906. ² Department of Defense Military Standard MIL-STD-621A (Method 100, etc.). ³ Department of the Army Materials Testing Field Manual FM 5-530 (2-III, etc.). ⁴ Do not use the standard laboratory test for determining consolidation. Instead, use the modified standard consolidation test and the self-weight consolidation test as described in USACE (1987). ⁵ One value of permeability must be calculated from the self-weight consolidation test.					

Additional geotechnical data should also be collected on contaminated sediments for capping projects, including consolidation, and shear strength data. These data are useful for geotechnical evaluations of stability of the capped deposit and the development of mound or deposit geometries. Detailed information on consolidation testing is presented in Appendix I.

Physical analysis of dredging site and/or disposal site water may also be required to include suspended solids concentration and salinity. Potential stratification due to temperature and salinity differences should be considered. These data must be developed using standard techniques.

Chemical/biological characterization

Capping as a control measure is normally considered only after a sediment to be dredged is found to be contaminated. In order to make such a determination, some chemical and biological characterization of

the contaminated sediment is normally performed as a part of the overall evaluation for suitability for open-water placement (EPA/USACE 1991; EPA/USACE 1998). It should be noted that even though capping is being considered because of a determination of potentially unsuitable benthic effects, the data necessary for evaluation of potential water column effects are still required.

Chemical characterization of contaminated sediment may include a sediment chemical inventory and standard elutriate test results. The chemical sediment inventory is useful in determining contaminants of concern and in the development of appropriate chemical elements of a monitoring program to determine capping effectiveness. Elutriate data are used in estimating the potential effects on water quality due to placement of the contaminated material. Biological characterization may include water column bioassays, benthic bioassays, and bioaccumulation tests. The results of these biological tests are useful in determining potential water column effects during placement and acceptable exposure times before placement of the cap begins. If these data have not been developed for the contaminated sediment, additional testing may be required.

Selection of Capping Sediment

The capping sediment used in a capping project may be a matter of choice. For economic reasons, a capping sediment is usually taken from an area that also requires dredging. If this is the case, there may be a choice between projects, and scheduling of the dredging is an important consideration. In other cases, removal of bottom sediments from areas adjacent to the capping site may be considered. If CAD is under consideration, removal of material to create CAD cells may be stockpiled and used later in the capping operation (Averett et al. 1989; Sumeri 1989).

Characterization of Capping Sediment

All dredged material capping projects to date have utilized dredged material that is suitable for open-water placement for the capping material. Use of other materials for caps or for components of a multilayer cap such as quarry sand, soil materials, geotextiles, or armor stone are possible and have been implemented in in situ capping projects. Guidance (Palermo et al. 1996) on selection and use of such materials for caps is available. This section focuses on use of dredged material as capping material.

Physical characterization

Physical characteristics of the capping sediment are similarly determined as described above for the contaminated sediment. Visual classification, natural (in situ) water content/solids concentration, plasticity indices (Atterberg limits), organic content, grain-size distribution, specific gravity,

and Unified Soil classification as well as geotechnical data should be evaluated as necessary.

The characteristics of the capping sediment should be compatible with the contaminated sediment, considering the placement technique for both. Previous studies have shown that both fine-grained materials and sandy materials can be effective capping materials.

Chemical/biological characterization

The capping sediment must be one that is acceptable for unrestricted open-water placement (that is a clean sediment). Further, the capping sediment must be acceptable for open-water placement from the standpoint of both potential water column and potential benthic effects. In order to make such a determination, some chemical and biological characterization of the contaminated sediment is normally performed as a part of the overall evaluation for suitability for open-water placement (EPA/USACE 1991; EPA/USACE 1998).

Sampling and Testing Plans

Samples of sediments must be obtained for physical, chemical, or biological characterization as described above. Samples may also be required for other engineering or environmental testing such as the capping thickness testing described in Chapter 7 and Appendix C.

General guidance on design of sampling plans is available (EPA/USACE 1991; EPA/USACE 1998), but most sampling plans will be site specific. The full range of anticipated testing must be considered in developing sampling plans. Appropriate sampling equipment, sampling techniques, and sample preservation procedures should be used.

Variability can be exhibited in vertical as well as horizontal location of specific samples. Sampling should define material to the total depth of dredging. Grab samplers or box corers are generally appropriate for shallow thickness of sediment, while core samples (by vibracore or conventional coring equipment) are normally required for thicker sediment deposits or deposits in which stratification must be defined. Detailed guidance on sampling equipment and procedures is available (Mudrock and McKnight 1991.)

Testing of samples from specific locations is usually done for characterization purposes. Compositing should be considered for some engineering or environmental testing (e.g., consolidation tests, elutriate tests, bioassays, capping effectiveness tests). Administrative agreement between all concerned regulatory agencies regarding the acceptability of the sampling and testing plan should be obtained prior to sampling and testing.

4 Site Selection Considerations for Capping

General Considerations for Site Selection

The selection of an appropriate site is a critical requirement for any capping operation. Since the cap must provide long-term isolation of the contaminated material, capping sites should generally be characterized as nondispersive sites, where material is intended to remain in a stable deposit. Therefore, the considerations for site selection for a conventional nondispersive open-water disposal site also apply to capping sites (Palermo 1991b).

Sites in ocean waters are regulated by MPRSA. For MPRSA sites, a formal site designation procedure includes a detailed evaluation of site characteristics. Sites in inland and near-coastal waters (inland of the baseline of the territorial sea) are regulated by CWA. The specification of disposal sites under the CWA is addressed specifically in the Section 404 (b)(1) guidelines. Any capping project in waters of the United States must occur at a specified 404 site.

A number of site characteristics must be considered in designating or specifying an open-water disposal site. These characteristics include the following:

- Currents and wave climate.
- Water depth (including consideration of navigable depth).
- Bathymetry (particularly slopes).
- Potential changes in circulation or erosion patterns related to refraction of waves around the disposal mound.
- Groundwater flow (consideration for some nearshore sites).
- Bottom sediment physical characteristics, including sediment grain-size differences.

- Sediment deposition versus erosion to include seasonal and long-term trends.
- Salinity and temperature distributions.
- Normal level and fluctuations in background turbidity.
- Chemical and biological characterization of the site and environs (for example, relative abundance of various habitat types in the vicinity, relative adaptability of the benthos to sediment deposition, presence of submersed aquatic vegetation, presence of unique, rare, or isolated benthic populations, contaminant concentrations in sediments, background water quality).
- Potential for site recolonization
- Previous disposal operations.
- Availability of suitable equipment for disposal at the site.
- Ability to monitor the disposal site adequately and economically for management decisions.
- Technical capability to implement management options should they appear desirable.
- Ability to control placement of the material.
- Volumetric capacity of the site.
- Other site uses and potential conflicts with other activities (i.e., sport or recreational fisheries).
- Established site management or monitoring requirements.
- Public and regulatory acceptability to use of the site.

The intent of the MPRSA criteria for site designation is to avoid unacceptable adverse impacts on biota and other amenities. The Section 404(b)(1) guidelines generally address the same concerns as the MPRSA criteria, but the primary emphasis is directed toward the potential effects of the disposal activity.

The USACE has prepared an ocean site designation manual (Pequegnat, Gallaway, and Wright 1990), which provides useful guidance and procedures for conducting the appropriate investigations and studies. In addition, overview manuals for site designation are available (USACE/EPA 1984; EPA 1986).

The selection of a potential site for capping is subject to the same constraints and tradeoffs as any other nondispersive open-water disposal site. However, beyond the normal considerations, the capping site should be in a relatively low-energy environment with little potential for erosion of the cap. While capping at a low-energy site is desirable, such sites are not always available. Higher energy sites can be considered for dredged material

capping, but a detailed study of erosion potential is required; increases in cap thickness to account for potential erosion may be required. Monitoring and maintenance costs may also be higher for higher energy sites.

Special consideration of site bathymetry, currents, water depths, bottom-sediment characteristics, and operational requirements such as distance, sea state, etc., are required in screening or selecting sites for capping (Truitt 1987a; Truitt, Clausner, and McLellan 1989).

Bathymetry

Site bathymetry influences the degree of spread during placement of both contaminated and capping material. The flatter the bottom slope, the more desirable it is for LBC projects, especially if material is to be placed by hopper dredge. If the bottom in a disposal area is not horizontal, a component of the gravity force influences the energy balance of the bottom surge (the lateral movement of the disposed material as it impacts sea bottom) and density flows due to slope following impact of the discharge with the bottom. It is difficult to estimate the effects of slope alone, since bottom roughness plays an equally important role in the mechanics of the spreading process. To date, LBC projects in which the material was mechanically dredged and released from a barge have been executed at sites with slopes up to 1:60 (Science Applications International Corporation (SAIC) 1995a) and in which material was placed by hopper dredge at sites with slopes up to 1:225 (i.e., New York Mud Dump site). Placement of material on steep bottom slopes (steeper than one degree 1:60) should generally be avoided for a capping project (Truitt 1987a). Bathymetry forming a natural depression tends to confine the material, resulting in a CAD project. This is the most desirable type of site bathymetry for a capping project.

Currents

Water column currents affect the degree of dispersion during placement and mound location with respect to the point of discharge. Of more importance are bottom currents, which could potentially cause resuspension and erosion of the mound and cap. The effects of storm-induced waves on bottom-current velocities must also be considered. Capping sites need to have current and wave climate characteristics that result in long-term stability of the capped mound or deposit.

Collection of basic current information is necessary at prospective disposal sites to identify site-specific conditions. The principal influence of currents in the receiving water during placement is to displace or offset the point of impact of the descending jet of material with the bottom with respect to the point of release (by a calculable amount). Water column currents need not be a serious impediment to accurate placement, nor do they result in significantly greater dispersion during placement (though the offset

needs to be taken into account). Further, currents do not appear to affect the surge phase of the disposal (Bokuniewicz et al. 1978; Truitt 1986a). However, water column currents and bottom slopes are important in slow placement of sand caps where the currents and density flows can cause some waste of capping material.

Long-term effects of currents at a prospective site may still need to be investigated from the standpoint of potential erosion of the mound and cap or potential recontamination of the site from adjacent sources. Storm-induced currents are also of interest in the long-term stability of the site. However, disposal operations are not conducted during storms, so the designer does not need to consider storm-induced currents during disposal. Measured current data can be supplemented by estimates for extreme events using standard techniques; for example, see the Shore Protection Manual (HQUSACE 1984). Selection of a nondispersive site in a relatively low-energy environment normally results in a site with low bottom-current velocity and little potential for erosion. However, in some cases, particularly if the material is hydraulically placed, a thorough analysis of the potential for resuspension and erosion is necessary. In the analysis of erosion, the effects of self-armoring due to the winnowing away of finer particles are a factor that increases erosion resistance over time but is difficult to quantify.

The same technical approaches used to evaluate erosion potential and/or magnitude and rate of erosion for purposes of cap design can be used in screening and/or selecting sites. The process of screening and site evaluation for erosion potential must consider current and wave conditions for both ambient and episodic events such as storms. Conventional methods for analysis of sediment transport can be used to evaluate erosion potential (Teeter 1988; Dortch et al. 1990). These methods can range from simple analytical techniques to numerical modeling (Scheffner et al. 1995). Modeling evaluations will normally result in a varying rate of erosion for various portions of a site or mounded feature (e.g., erosion would normally be greater at the crest of a mound or at the corners of a mounded feature).

Erosion criteria for site screening should also be based on both ambient and episodic events and should account for a varying rate of erosion over the site. For projects in which no subsequent capping is anticipated for a long time period (several decades or longer) or for which materials for cap nourishment are not easily obtained, it is suggested that net cap erosion over the major portion of the mound or deposit should not exceed 1 ft¹ over a period of 20 years of normal current/wave energies or for a 100-year extreme event. The recommended criteria of 1 ft of erosion, 20-year ambient time interval, and 100-year return interval for storms is based on engineering judgement, a common sense level of conservatism, and field experience gained to date. One foot is a round number that can be measured with some precision for most locations. Twenty and one hundred years as

¹ The U.S. customary units of measurement are used in lieu of metric (SI) units for those cases common in dredging practice. Metric (SI) units are used in this report when consistent with standard usage. A table to convert from non-SI units of measurement to SI units can be found on page xiv.

time periods are in the range of design periods for many engineering structures. Note that erosion at localized portions of the mound or feature greater than 1 ft would be allowed using these screening criteria. The corners of a mound would normally have an overlap of capping material, and the crest of a mound would normally have a greater cap thickness; therefore, somewhat larger erosion could be tolerated over these portions of a mound. Selection of other values of erosion thickness or time periods should be based on site-specific factors (e.g., the degree of contamination, distance to other resources), the level of confidence in the calculations, and the level of risk acceptable to the parties involved.

For projects in which subsequent material placement and/or capping is planned or for which materials for cap nourishment can be easily obtained, higher erosion rates or shorter return periods for episodic events may be considered as a criterion for purposes of site screening. In areas where available capping materials are scarce and current and wave conditions are severe, a coarse-grained layer of material (coarse sand, gravel, or larger size materials) may be incorporated into the cap design to provide protection against erosive currents at the site. Detailed guidance on evaluation of erosion is found in Chapter 8 and Appendixes F and G.

Average Water Depths

Case studies have indicated that water depth is of particular interest in evaluating the potential suitability of a site for capping operations (Palermo 1989). The deepest water depth for which a capping project has been executed (as of 1995) is approximately 100 ft. However, definable dredged material mounds have been created in water depths exceeding 400 ft (Wiley 1995). Greater water depths generally provide more stable bottom conditions with less potential for erosion. However, the greater the average water depth is at the site, the greater the potential is for water entrainment and dispersion during placement. The expense and difficulty in monitoring is also increased with a greater water depth.

As water depth increases, both the contaminated and clean material must descend through a greater water column depth. More material is released to the water column during placement as compared with shallower water placement, all other factors being equal. Therefore, the fraction of the contaminated material that is not finally capped is greater.

Entrainment of ambient water causes the descending material to become more buoyant; therefore, the effect of density stratification in the water column needs to be evaluated. Although density stratification in the water column may be encountered at some deep-water sites, stratification is not likely to prevent the descent of the dredged material mass during placement. The very cohesive fraction of mechanically dredged material (clods or clumps) attains terminal speed quickly after release from a barge and does not accelerate further with depth.

The increased water entrainment with deep-water placement may also result in a greater spread of the more fluid material on the bottom, but entrainment reduces the overall potential energy at bottom impact. Field studies indicate that the bottom surge does not spread at a faster rate than that occurring in shallower depths, although because of additional entrainment, the initial thickness of the surge increases as depth increases (Bokuniewicz et al. 1978). Greater care in control of placement may therefore be required as water depth increases to develop a discrete mound of contaminated material and adequate coverage of the mound with capping material.

Comparison of predictive models for fate of placed material and field monitoring of Puget Sound Dredge Disposal Analysis (PSDDA) sites in Seattle's Elliott Bay and Everett's Port Gardner Bay show the high degree of reliability of these models for prediction of mound footprint extent in water depths of 300 to 400 ft (Wiley 1995). Also, the accuracy of available electronic positioning equipment used during disposal is validated.

The use of a deep-water site for capping generally holds an advantage over a shallower site from the standpoint of cap stability from erosive forces. Deep water acts as a buffer to wave action, and the resulting wave-induced currents from storm events are smaller than in shallow water. Therefore, deep-water sites are usually quiescent, near bottom low-energy environments that are better suited to capping from the standpoint of cap stability, but this must be balanced against potential material loss during placement. Generally, a greater water depth at a site has more favorable influence on long-term cap stability than unfavorable influence on dispersion during the placement process (Truitt 1986b).

Operational Requirements

Among the operational criteria that need to be considered in evaluating potential capping sites are site volumetric capacity, nearby obstructions or structures, haul distances, bottom shear due to ship traffic (in addition to natural currents), location of available cap material, potential use of bottom drag fishing equipment, and ice influences. The effects of shipping are especially important since bottom stresses due to anchoring, propeller wash, and direct hull contact at shallow sites are typically of a greater magnitude than the combined effects of waves and other currents (Truitt 1987a). Methods for calculating prop-wash velocities are available (Palermo et al. 1996).

5 Equipment and Placement Techniques

Equipment and techniques applicable to placement of contaminated material to be capped and clean material used for capping include conventional discharge from barges, hopper dredges, and pipelines; diffusers and tremie approaches for submerged discharge; and spreading techniques for cap placement (Palermo 1991c, 1994). This chapter describes basic dredging, transportation, and placement processes as they relate to capping and considerations in selecting equipment and placement technique for both contaminated and capping materials. Considerations for scheduling for placement of the cap, navigation and positioning needs, placement options and tolerances, and inspection and compliance are also discussed.

Flow and Mounding Versus Dredging Method

The behavior of materials upon placement (especially their tendency to mound or to flow) and the ability to cap a deposit of contaminated material depend on several factors, including the method of dredging, the method of placement, material characteristics (cohesive/noncohesive), and site conditions such as water depth or current velocities (Headquarters, U.S. Army Corps of Engineers 1983).

The dredging process may be subdivided into two categories: mechanical and hydraulic dredging. During mechanical dredging, the sediments are physically lifted from the bottom by a mechanical process such as a bucket or clamshell. Mechanically dredged material is typically placed into and transported to the disposal area in barges (also commonly known as dump scows). Barges either have hoppers with doors through which material is released to the bottom or they can be split-hull, allowing the entire barge to open and release material to the bottom. Mechanically dredged material placed in this manner is ideally suited for creating subaqueous mounds because the dredged material stays close to the in situ density throughout the dredging process. This relatively constant density lends to effective mound construction because less water is entrained in the material, stripping during descent is minimized, and material spread on the bottom is reduced (Sanderson and McKnight 1986).

During hydraulic dredging, the bottom material is fluidized, lifted via pipeline by a centrifugal pump, and transported as a slurry. Material dredged by hopper dredges is also considered hydraulic dredging because of the fluidization process required to lift the material to the hoppers. Hydraulically dredged material is typically transported via pipeline to the disposal site and discharged with large amounts of entrained water. For hopper dredges, the material is transported in the hopper similar to a barge or scow as with the mechanical dredging, but excess water that is entrained during dredging remains with the material, thereby making the material less dense than when in situ or mechanically dredged. For both cases of hydraulic dredges (pipeline and hopper), the less dense material is more susceptible to stripping and creates a flatter feature covering a larger area on the bottom (Sanderson and McKnight 1986).

Alternatives are available to increase the mounding potential of material dredged by hydraulic means. For pipeline dredges, diffusers can be employed to reduce the material exit velocity from the pipe and reduce dispersion. Pump-down pipes can be added to transfer the material closer to the bottom and reduce losses due to stripping as the material falls through the water column. For hopper dredges, the spread of material on the bottom can be reduced by having the dredge come to a stop during placement.

Dredged material characteristics also contribute to mounding potential. Cohesive and noncohesive materials will tend to mound when dredged using mechanical means and point dumped (i.e., from a barge). Both cohesive and noncohesive material will tend to flow if hydraulically dredged and point dumped (i.e., discharged from a pipe). In cases where a pump-down pipe is incorporated for hydraulically dredged material, noncohesive material tends to mound, while cohesive material tends to flow.

Table 2 summarizes available information on the mounding or flowing characteristics of cohesive versus noncohesive sediments for various dredging and placement methods. This information can be used in evaluating various equipment and placement techniques for a given set of site conditions.

Considerations for Contaminated Material Dredging and Placement

Placement of contaminated material for a capping project should be accomplished so that the resulting deposit can be defined by monitoring and effectively capped. Therefore, the equipment and techniques for dredging, transport, and placement must be compatible with that of the capping material. Since capping is a contaminant control measure for potential benthic effects, the contaminated material should be placed such that the exposure of the material prior to capping is minimized. In most cases, the water column dispersion and bottom spread occurring during placement should also be reduced to the greatest possible extent. This minimizes the release of contaminants during placement and provides for easier capping. If the placement of the contaminated sediment has potentially unacceptable

**Table 2
Flow Characteristics of Dredged Material Placed in Aquatic Sites (Shields and Montgomery 1994)**

Dredged Material Characteristics	Placement Method	
	Point Dump	Pump Down
Nocohesive Material		
Mechanically Dredged	Tends to mound	Not applicable
Hydraulically Dredged	Tends to flow ^{1,2,3}	Tends to mound ⁴
Cohesive Material		
Mechanically Dredged	Tends to mound ^{1,2}	Not applicable
Hydraulically Dredged	Tends to flow ¹	Tends to flow ²
¹ JBF Scientific Corporation 1975. ² Morton 1983a. ³ Sustar and Eker 1972. ⁴ Nichols, Thompson, and Faas 1978.		

water column impacts, controls to specifically reduce water column dispersion (for example, submerged discharge) may be required.

For LBC, the dredging equipment and placement technique for contaminated sediment must result in a tight, compact mound that is easily capped. Compact mounds generally result when the material is dredged and placed at or near its in situ density prior to dredging. This is most easily accomplished with mechanical dredging techniques and precision-point discharges from barges.

For CAD projects, the provision for lateral containment in the form of a bottom depression or other feature defines and limits the extent of bottom spread. For this reason, either mechanical dredging or hydraulic placement of the contaminated material may be acceptable for CAD. If the contaminated material is placed hydraulically, a suitable time period (usually a few weeks) must be allowed for settling and consolidation to occur prior to placement of the capping material to avoid potential mixing of the materials unless capped by slow sprinkling of sand.

Considerations for Capping Material Placement

Placement of capping material is accomplished so that the deposit forms a layer of the required thickness over the contaminated material. For most projects, the surface area of the contaminated material to be capped may be several hundred feet or more in diameter. Placement of a cap of required thickness over such an area may require spreading the material to some degree to achieve coverage.

The equipment and placement technique are selected and rate of application of capping material is controlled to avoid displacement or mixing with the previously placed contaminated material to the extent possible. Placement of capping material at equal or lesser density than the contaminated material or use of placement methods to spread thin layers to gradually build up the cap thickness generally meets this requirement. However, sand caps have been successfully placed over fine-grained contaminated material. Since capping materials are not contaminated, water column dispersion of capping material is not usually of concern (except for loss when slowly placing a sand cap); the use of submerged discharge for capping placement need only be considered from the standpoint of placement control.

Equipment and Placement Techniques

The equipment and placement techniques described in the following paragraphs apply to the contaminated dredged material to be capped as well as to the capping material, depending on the project conditions. Regardless of the equipment and placement techniques considered, the compatibility of contaminated material placement and capping operations must be determined considering the material characteristics and site conditions (Palermo 1991a,c).

Surface discharge using conventional equipment

Dredged material released at the water's surface using conventional equipment tends to descend rapidly to the bottom as a dense jet with minimal short-term losses to the overlying water column (Bokuniewicz et al. 1978; Truitt 1986a). Thus, the use of conventional equipment can be considered for placement of both contaminated and capping material if the bottom spread and water column dispersion resulting from such a discharge are acceptable.

The surface release of mechanically dredged material from barges results in a faster descent, tighter mound, and less water column dispersion as compared with surface discharge of hydraulically dredged material from a pipeline. Placement characteristics resulting from surface release of hydraulically dredged material from a hopper dredge fall between the characteristics resulting from surface release of hydraulically dredged material from barges and from surface discharge of hydraulically dredged material from a pipeline—that is, the descent is slower than the former but faster than the latter; the mound is looser than the former but tighter than the latter; and more water column dispersion results from the former than from the latter.

Field experiences with LBC operations in Long Island Sound and the New York Bight as described in Chapter 10 have shown that mechanically dredged silt and clay released from barges tend to remain in clumps during descent and form nonflowing discrete mounds on the bottom that can be effectively capped. Such mounds have been capped with both mechanically

dredged material released from barges and with material released from hopper dredges (O'Connor and O'Connor 1983; Morton 1983a, 1987). In fact, mechanically dredged cohesive sediments often remain in a clumped condition, reflecting the shape of the dredge bucket. Mounds of such material are stable, resist displacement during capping operations, and present conditions ideal for subsequent LBC (Sanderson and McKnight 1986). However, these mounds may experience initial surface erosion due to irregular surface geometry and higher friction coefficients. A conceptual illustration showing the use of conventional equipment for capping is shown in Figure 3.

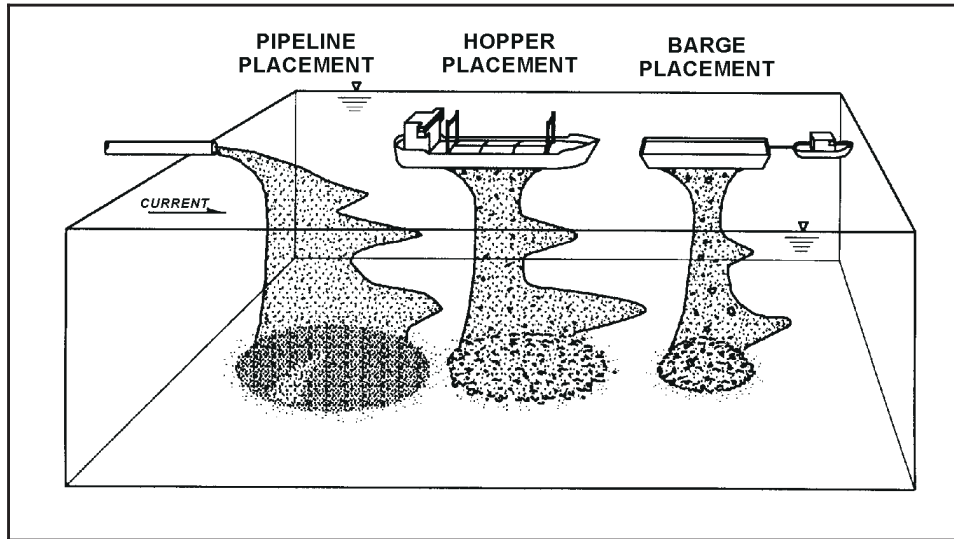

Figure 3. Conventional open-water placement for capping (after Palermo 1991c)

Spreading by barge movement

A layer of capping material can be spread or gradually built up using bottom-dump barges if provisions are made for controlled opening or movement of the barges. This can be accomplished by slowly opening a conventional split-hull barge over a period of tens of minutes, depending on the size of the barge and site conditions. Such techniques have been successfully used for controlled placement of predominantly coarse-grained, sandy capping materials (Sumeri 1989). The gradual opening of the split-hull or multicompartmented barges allows the material to be released slowly from the barge in a sprinkling manner. If tugs are used to slowly move the barge during the release, the material can be spread in a thin layer over a large area (Figure 4). Multiple barge loads are necessary to cap larger areas in an overlapping manner. The gradual release of mechanically dredged fine-grained silts and clays from barges may not be possible due to potential “bridging” action; that is, the cohesion of such materials may cause the entire barge load to “bridge” the split-hull opening until a critical point is reached at which time the entire barge load is released. If the water content of fine-grained material is high, the material exits the barge in a matter of seconds as a dense slurry, even though the barge is only partially opened.



Figure 4. Spreading technique for capping by barge movement

Spreading of thin layers of cap material over large areas can also be accomplished by gradually opening a conventional split-hull barge while underway by tow. These techniques were used for in situ capping operations at Eagle Harbor, Washington (Sumeri 1995).

Hydraulic washing of coarse sand

Granular capping materials such as sand can be transported to a site in flat-topped barges and washed overboard with high-pressure hoses. Such an operation was used to cap a portion of the Eagle Harbor, Washington, Superfund site, forming a cap layer of uniform thickness (Figure 5) (Nelson, Vanderheiden, and Schuldt 1994). This technique produces a gradual buildup of cap material, prevents any sudden discharge of a large volume of sand, and may be suitable for water depths as shallow as 10 ft or less.

Spreading by hopper dredges

Hopper dredges can also be used to spread a sand cap. During the summer and fall of 1993, the Port Newark/Elizabeth capping project in New York Bight used hopper dredges to spread a sand cap over 580,000 cu yd of contaminated sediments. To facilitate spreading the cap in a thin layer (6 in.) to quickly isolate the contaminants and to lower the potential for re-suspension of the contaminated material, conventional point dumping was not done. Instead, a split-hull dredge cracked the hull open 1 ft and released its load over a 20- to 30-min period while sailing at 1 to 2 knots. Also, as an alternative means of placing the cap, another dredge used pump-out over the side of the vessel through twin vertical pipes with end



Figure 5. Pressure-hose washing method of placement

plates to force the slurry into the direction the vessel was traveling. As with the cracked-hull method described above, injecting the slurry into the direction of travel of the vessel increased turbulence, reducing the downward velocity of the slurry particles and thus the potential for resuspension of the contaminated sediments. Computer models (see Chapter 6) were used to predict the width of coverage from a single pass and the maximum thickness produced (Randall, Clausner, and Johnson 1994).

Pipeline with baffle plate or sand box

Spreading placement for capping operations can be easily accomplished with surface discharge from a pipeline aided by an energy-dissipating device such as a baffle plate or sand box attached to the end of the pipeline.

Hydraulic placement is well suited to placement of thin layers over large surface areas.



Figure 6. Spreader plate for hydraulic pipeline discharge

A baffle plate (Figure 6), sometimes called an impingement or momentum plate, serves two functions. First, as the pipeline discharge strikes the plate, the discharge is sprayed in a radial fashion; the discharge is allowed to fall vertically into the water column. The decrease in velocity reduces the potential of the discharge to erode material already in place. Second, the angle of the plate can be adjusted so that the momentum of the discharge exerts

a force that can be used to swing the end of the floating pipeline in an arc. Such plates are commonly used in river dredging operations where material is deposited in thin layers in areas adjacent to the dredged channel (Elliott 1932). Such equipment can be used in capping operations to spread thin layers of material over a large area, thereby gradually building up the required capping thickness.

A device called a “sand box” (Figure 7) serves a similar function. This device acts as a diffuser box with baffles and side boards to dissipate the energy of the discharge. The bottom and sides of the box are constructed as an open grid or with a pattern of holes so that the discharge is released through the entire box. The box is mounted on the end of a spud barge so that it can be swung about the spud using anchor lines (Sumeri 1989).



Figure 7. Spreader box or “sand box” for hydraulic pipeline discharge

Submerged discharge

If the placement of the contaminated sediment with surface discharge results in unacceptable water column impacts, or if the anticipated degree of spreading and water column dispersion for either the contaminated or capping material is unacceptable, submerged discharge is a potential control measure.

In the case of contaminated dredged material, submerged discharge serves to isolate the material from the water column during at least part of its descent. This isolation can minimize potential chemical releases due to water column dispersion and significantly reduce entrainment of site water, thereby reducing bottom spread and the area and volume to be capped. In the case of capping material, the use of submerged discharge provides additional control and accuracy during placement, thereby potentially reducing the volume of capping material required. Several equipment

alternatives are available for submerged discharge (Palermo 1994) and are described in the following paragraphs.

Submerged diffuser

A submerged diffuser (Figures 8 and 9) can be used to provide additional control for submerged pipeline discharge. The diffuser consists of conical and radial sections joined to form the diffuser assembly, which is mounted to the end of the discharge pipeline. A small discharge barge is required to position the diffuser and pipeline vertically in the water column. By positioning the diffuser several feet above the bottom, the discharge is isolated from the upper water column. The diffuser design allows material to be radially discharged parallel to the bottom and with a reduced velocity. Movement of the discharge barge can serve to spread the discharge to cap larger areas. The diffuser can also be used with any hydraulic pipeline operation including hydraulic pipeline dredges, pump-out from hopper dredges, and reslurried pump-out from barges.

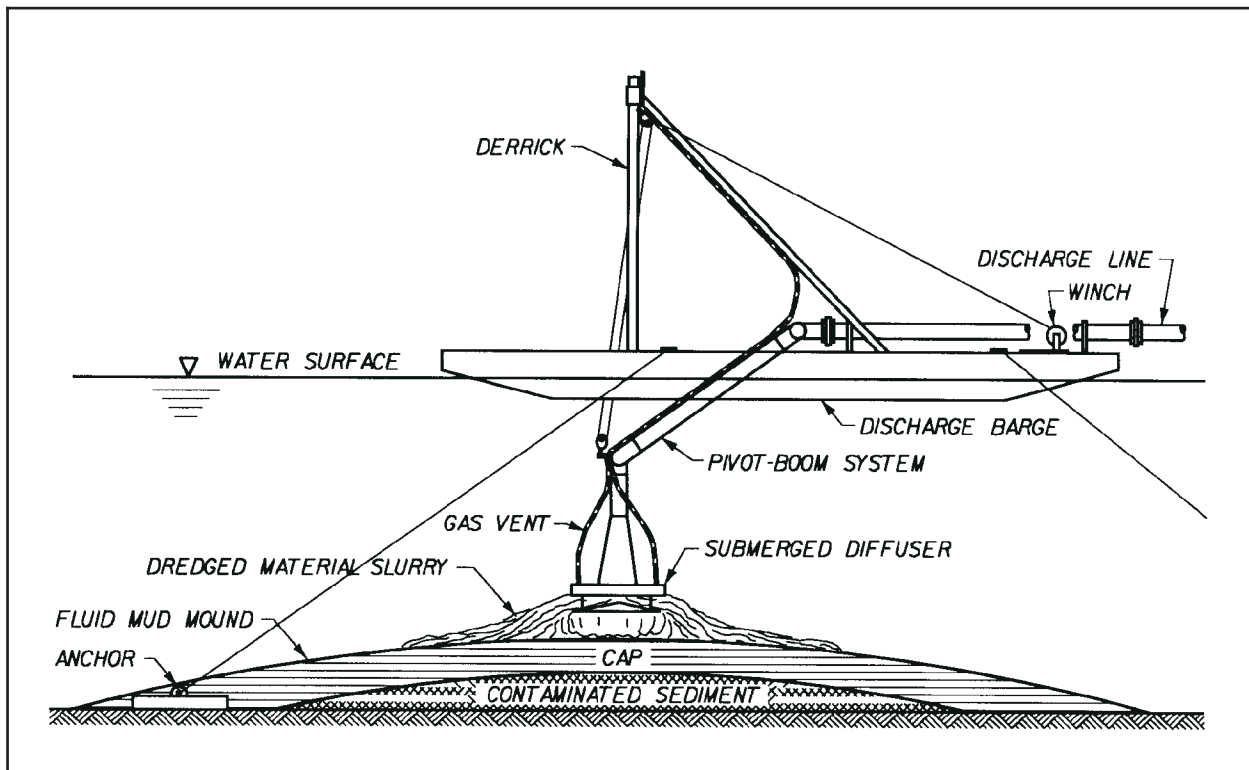

Figure 8. Submerged diffuser system, including diffuser and discharge barge

A design for a submerged diffuser system was developed by JBF Corporation as a part of the USACE Dredged Material Research Program (DMRP) (Barnard 1978; Neal, Henry, and Greene 1978). This design consists of a funnel-shaped diffuser oriented vertically at the end of a submerged pipeline section that discharges the slurry radially. The diffuser and pipe section are attached to a pivot boom system on a discharge barge.

Design specifications for this submerged diffuser system are available (Neal, Henry, and Greene 1978; Palermo, in preparation).

A variation of the DMRP diffuser design was used in an equipment demonstration at Calumet Harbor, Illinois. Although not constructed to the DMRP specifications, this diffuser significantly reduced pipeline exit velocity, confined the discharged material to the lower portion of the water column, and reduced suspended solids in the upper portion of the water column (Hayes, McLellan, and Truitt 1988). Diffusers have been constructed using the DMRP design and used at a habitat creation project in the Chesapeake Bay (Earhart, Clark, and Shipley 1988) and at a Superfund pilot dredging project at New Bedford Harbor, Massachusetts, involving subaqueous capping (USACE 1990). At the Chesapeake Bay site, the diffuser was used to effectively achieve dredged material mounding prior to placement of a layer of oyster shell to provide substrate for attachment of oyster spat. At the New Bedford site, the diffuser was used to place contaminated sediment in an excavated subaqueous cell and was effective in reducing sediment resuspension and in controlling placement of contaminated sediment. However, capping operations were started immediately, and positioning of the diffuser within 2 ft of the contaminated sediment layer resulted in mixing of cap sediment with contaminated sediment. These results indicate the need for a high degree of control when capping newly placed slurry with a diffuser and the need for adequate time to allow for some self-weight consolidation of slurry material prior to capping. Diffusers have also been successfully used to place and cap contaminated sediments at projects in Rotterdam Harbor in the Netherlands (d'Angremond, de Jong, and de Waard 1986) and in Antwerp Harbor in Belgium (Van Wijck and Smits 1991).



Figure 9. Submerged diffuser

Sand spreader barge

Specialized equipment for hydraulic spreading of sand for capping has been used by the Japanese (Kikegawa 1983; Sanderson and McKnight 1986). This equipment employs the basic features of a hydraulic dredge with submerged discharge (Figure 10). Material is brought to the spreader by barge, where water is added to slurry the sand. The spreader then pumps

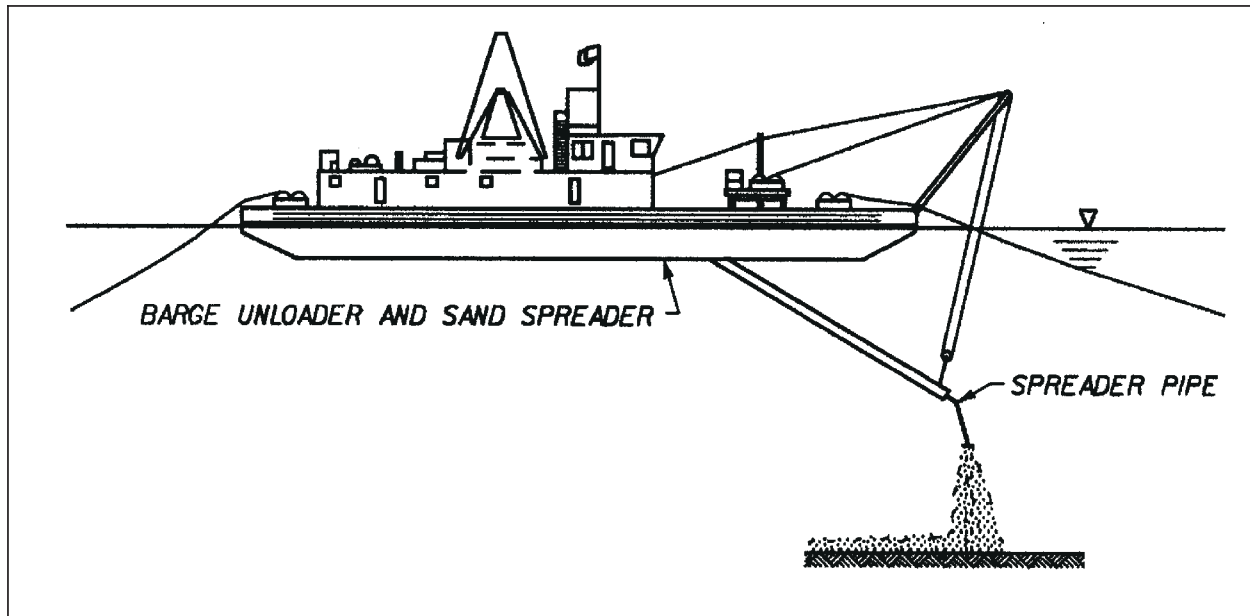

Figure 10. Hydraulic barge unloader and sand spreader barge (from Kikegawa 1983)

the slurried sand through a submerged pipeline. A winch and anchoring system are used to swing the spreader from side to side and forward, thereby capping a large area.

Gravity-fed downpipe (tremie)

Tremie equipment can be used for submerged discharge of either mechanically or hydraulically dredged material. The equipment consists of a large-diameter conduit extending vertically from the surface through the water column to some point near or above the bottom. The conduit provides the desired isolation of the discharge from the upper water column and improves placement accuracy. However, because the conduit is a large-diameter straight vertical section, there is little reduction in momentum or impact energy over conventional surface discharge. The weight and rigid nature of the conduit require a sound structural design and consideration of the forces due to currents and waves.

The Japanese have used tremie technology in the design of specialized conveyor barges for capping operations (Togashi 1983; Sanderson and McKnight 1986). This equipment consists of a tremie conduit attached to a barge equipped with a conveyor (Figure 11). The material is initially placed in the barge mechanically. The conveyor then mechanically feeds the material to the tremie conduit. A telescoping feature of the tremie allows placement at depths of up to approximately 40 ft. Anchor and winch systems are used to swing the barge from side to side and forward so that larger areas can be capped, similar to the sand spreader barge.

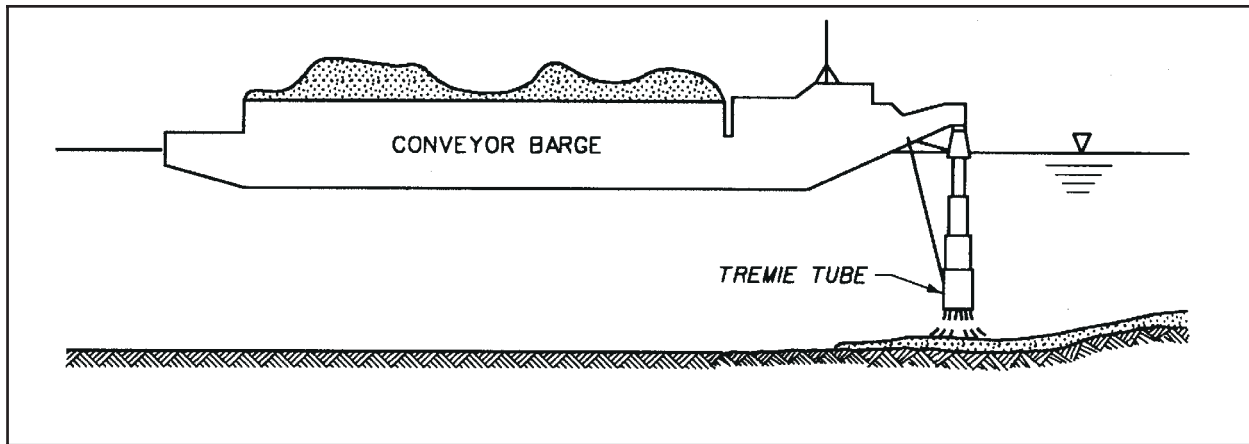

Figure 11. Conveyor unloading barge with tremie (from Togashi 1983)

Hopper dredge pump-down

Some hopper dredges have pump-out capability by which material from the hoppers is discharged like a conventional hydraulic pipeline dredge. In addition, some have further modifications that allow pumps to be reversed so that material is pumped down through the dredge's extended dragarms. Because of the expansion at the draghead, the result is similar to using a diffuser section. Pump-out depth is limited, however, to the maximum dredging depth, typically about 60-70 ft.

Use of geosynthetic fabric containers (GFCs)

Geosynthetic fabric containers (GFCs) are containers made from geosynthetic fabric that line barges. Contaminated dredged material is placed in the GFCs (either mechanically or hydraulically), which are then sewn closed prior to placing the GFC at the disposal site. The GFC acts as a filter cloth, allowing the water to escape but retaining almost all the fine (silt and clay) particles. Containing contaminated sediments in GFCs for subsequent placement from split-hull barges offers the potential to eliminate the wide, thin apron normally associated with conventional bottom dumping of fine-grained sediments, thus substantially reducing the volume of cap material required and reducing the potential for contaminated sediments to extend beyond the site boundary. GFCs also have the potential to eliminate water quality problems at the disposal site by essentially eliminating loss of fine sediment particulates and associated contaminants to the water column.

As of 1996, GFCs have been used on only two USACE projects. The first was construction of training dikes in the lower Mississippi River (Duarte, Joseph, and Satterlee 1995), and the second was placement of sandy sediment with heavy metal contaminants in a CAD site in Los Angeles Harbor (Mesa 1995). At present, costs of using GFCs are much higher than for conventional bottom placement due to costs of materials, increased dredge cycle times, increased labor requirements associated with installation of the GFCs in the barge, and possible reductions in dredge

production rate. There are also considerable engineering problems associated with successfully deploying the GFCs without having them rupture. The decision to use GFCs for a capping project should be made based on the benefits versus costs rather than a blanket decision based solely on the desire to reduce losses to the water column. Data collected from a 1996 demonstration of GFCs conducted jointly by New York District and the Port of New York and New Jersey should provide additional data on GFC viability. However, additional research is needed to better define GFC abilities to reduce water column losses of contaminants and to refine engineering aspects associated with deployment. Clausner et al. (1996) summarizes the present state of the art on using GFCs with contaminated sediments.

Geotechnical Compatibility of Operations

Geotechnical considerations are important in capping because of the fact that most contaminated sediments are fine-grained silts and clays and usually have high water contents and low shear strengths in situ. Once sediments are dredged and placed at a subaqueous site, the water contents may be initially higher and the shear strengths initially lower than in situ.

Capping involves the placement of a layer of clean sediment of perhaps 3 ft or more in thickness over such low-shear-strength material. Field-monitoring data have definitively shown that contaminated sediments with low strength have been successfully capped with slow placement of sandy material. The geotechnical considerations involved can be described in terms of the ability of a capped deposit with given shear strength to support a cap from the standpoint of slope stability and/or bearing capacity (Ling et al. 1996).

Only limited geotechnical evaluations have been considered in past capping projects. In virtually all of past capping projects the design was empirical, i.e., prior field experience showed that it worked, but actual geotechnical design calculations were not conducted. Limited research on this topic is now underway, and more detailed guidance on this aspect of capping design will be provided in the future. Additional research is also planned to define geotechnical design for bearing capacity, slope failure, loading rate, impact penetration, etc. For the present time, geotechnical aspects of capping-project design are limited to the evaluation of compatibility of equipment and placement technique for contaminated and capping sediments with sediment properties. An acceptable match of equipment and placement techniques for contaminated and capping material is essential to avoid displacement of the previously placed contaminated material or excessive mixing of capping and contaminated material. The availability of certain types of equipment and the distance between dredging and placement sites may also influence selection of compatible equipment types.

The nature of the materials (cohesive versus noncohesive), the dredging method (mechanical versus hydraulic), the method of discharge (instantaneous dump from hopper dredge or barge versus continuous pipeline), the

location of discharge (surface or submerged), frequency and scheduling of discharges, physical characteristics of discharge material, and other factors influence the tendency of the material to mound or flow and the tendency to displace or mix with material already placed. The primary concern with compatibility relates to geotechnical considerations and the ability of the contaminated material to support the cap, considering the material characteristics and dredging and placement techniques.

In general, if the contaminated material were mechanically dredged and released from barges, the capping material can be similarly placed or could be placed hydraulically. However, if the fine-grained contaminated material were hydraulically placed, then only hydraulic placement of the capping material is appropriate due to the potentially low shear strength of the contaminated material. An exception may be the slow controlled placement of a sand cap. The exposure of the contaminated material to the environment and need to allow consolidation of the contaminated material to occur prior to cap placement must be balanced in scheduling both placement operations.

The flow characteristics data in Table 2 plus the field experience with capping operations to date were used to develop the compatibility information shown in Table 3 (Palermo 1994). This table may be used as an initial guideline in selecting compatible equipment and placement operations. It is anticipated that the table will be updated as more field experience and monitoring data become available for a wider range of project conditions.

Exposure Time Between Placement of Contaminated Material and Cap

Scheduling of the contaminated material placement and capping operation must satisfy environmental and engineering/operational constraints. Following the placement of contaminated material, there is necessarily some time lag prior to completion of the capping operation. This results in some degree of unavoidable exposure of colonizing benthic organisms to surficial portions of the contaminated material deposit. Placement of the cap material must begin as soon as practicable following completion of the placement of contaminated material to minimize this exposure time. However, a delay of 1 to 2 weeks is desirable from an engineering standpoint to allow initial consolidation of the contaminated material to occur, with an accompanying increase in shear strength, prior to placement of the cap.

Factors to consider in arriving at an appropriate exposure time are as follows:

- a.* Potential effects due to exposure prior to capping.
- b.* Estimates of time required for initial colonization of the site by benthic organisms.

**Table 3
Compatibility of Capping and Contaminated Material Placement Options**

Cap Material		Hopper or Barge Spread	Barge Point Disposal			Hopper Point Disposal			Pipeline				
			Sandy ¹	Clumps ²	Maint. silt/clay	Sandy	Clay balls ³	Slurry ⁴	Sandy	Clay balls	Slurry		
Contaminated Material	Pipeline ⁵	CAD slurry ⁶	I ⁷	I	I	I	I	I	I	C ⁸	I	C	
		Slurry clay balls	C	C	I	C	C	C	C	C	C	C	C
		Sandy	C	C	C	C	C	C	C	C	C	C	C
	Hopper ⁹	CAD slurry	I	I	I	I	I	I	I	C	I	C	
		Slurry clay balls	C	C	I	C	C	C	C	C	C	C	C
		Sandy	C	C	C	C	C	C	C	C	C	C	C
	Barge ¹⁰	Maint. silt/clay	C	I	I	C	I	I	C	C	I	C	
		Clumps	C	C	C	C	C	C	C	C	C	C	C
		Sandy	C	C	C	C	C	C	C	C	C	C	C

Note: The compatibility designation of incompatible (Footnote 7) and compatible (Footnote 8) is a general recommendation. Site-specific or material-specific considerations could over-ride these general designations.

- ¹ Sand - Predominantly cohesionless material (sand).
- ² Clumps - Predominantly fine-grained material mechanically dredged with in situ water content sufficiently low to cause clumping to occur and be maintained.
- ³ Clay balls - Small balls of clay formed during hydraulic dredging of fine-grained material.
- ⁴ Slurry - Predominantly fine-grained material hydraulically dredged (pipeline or hopper) with water content sufficiently high to allow slurry.
- ⁵ Pipeline - Material is used by hydraulic pipeline dredge (slurried) with direct pipeline transport for placement. May include use of submerged diffusers. Would include hopper dredge or barge pump-out (reslurried). For capping operations, appropriate means to spread the material is recommended. Clay balls are assumed to act as slurry.
- ⁶ Contaminated material in slurry form placed without lateral confinement (CAD) is not recommended for a capping project.
- ⁷ Generally incompatible.
- ⁸ Generally compatible.
- ⁹ Hopper - Material is dredged by trailing suction hopper (slurried) and transported directly to site for surface release. This would also include hydraulically filled barges.
- ¹⁰ Barge - Material is mechanically dredged, placed in barges, and transported to site for surface release (no slurry). Could either point dump or incorporate provision to sprinkle or spread material by controlled release from the barge.

- c. Estimates of time required for initial consolidation of the contaminated material due to self-weight.
- d. Monitoring requirements prior to cap placement.

The process of recolonization by opportunistic species may begin as soon as contaminated material placement operations are completed (Rhoads and Boyer 1982; Rhoads and Germano 1982). However, recruitment and colonization processes for many assemblages of coastal benthic organisms show definite seasonal peaks, usually a primary peak in spring and a secondary peak in fall. For example, Scott et al. (1987) determined that recolonization at a Long Island Sound dredged material disposal site showed peaks during October and December of separate years. Ideally, to minimize exposure durations of benthic organisms, placement of contaminated material and initiation of cap construction should occur prior to the onset of a seasonal recruitment pulse. During intervals between peaks, rates of colonization should be sufficiently slow to assume minimal exposure over a period of 3 to 4 weeks. Once cap construction has begun, those early colonizers of the contaminated deposit will be buried and thus physically isolated. Assuming that cap placement proceeded at a reasonable rate, it would be unlikely that any bioaccumulation that had occurred prior to cap placement would result in unacceptable effects.

Some delay between completion of contaminated material placement and initiation of capping is desirable from an engineering standpoint. Consolidation of the contaminated material and a corresponding increase in density and strength occur due to the weight of the material as it is placed in the deposit. This process is called self-weight consolidation. The contaminated material should be allowed to undergo initial self-weight consolidation prior to capping to increase its stability and resistance to displacement during cap placement. This is especially important for slurried materials placed by pipeline or by hopper dredge. For slurried materials, a large portion of the self-weight consolidation occurs within a few weeks of placement. Mechanically dredged materials placed by barge release are initially deposited at essentially the same density at which they were dredged, and the potential degree of self-weight consolidation is less than for slurried materials.

Monitoring is required to determine the areal extent of the contaminated deposit prior to capping. Surveys and other sampling and monitoring activities may require several weeks to complete. An appropriate delay between contaminated material placement and capping must balance environmental exposure with the engineering requirements of stability and scheduling constraints for monitoring and dredging required for capping. If appropriate precautions are taken to schedule the lag time for consolidation during periods of low benthic recruitment, a period of 3 to 4 weeks between completion of contaminated sediment placement and initiation of capping should have minimal environmental effect.

Navigation and Positioning Controls

Once the dredging equipment and placement techniques and potential capping site have been selected, the needs for navigation and positioning equipment and controls can be addressed. The objective here is to place both the contaminated and capping materials (whether by the bargeload, hopperload, or by pipeline) at the desired location in a consistently accurate manner so that adequate coverage by the cap is attained.

Navigation (the science of getting vessels from place to place) and positioning (accurately locating an object) are two of the most important factors in designing and implementing a successful capping project. Accurate positioning is necessary for any dredged material disposal operation in open water to ensure the material is located within the appropriate disposal site boundaries. For a capping project, contaminated material placement requirements are similar, but may be more restrictive in that placement of material within a specified radius, along a given linear transect, or similar location may be required. For the capping phase, materials must be adequately placed to cover the previously placed contaminated material. Therefore, knowing the precise navigation and positioning is of principal importance to allow proper capping.

For pipeline placement in shallow water, the desired positioning of the pipeline discharge can be maintained with little difficulty. Accurate navigation to the placement site and precise positioning during material placement by bottom-dump barge or hopper dredge is more difficult, especially for sites well offshore.

There exist a number of methods to position barges and hopper dredges for placement of dredged and cap material. One of the most common is placement near a taut-moored buoy. The other common methods are electronic positioning systems (EPS) including range-azimuth, LORAN-C (low-frequency), microwave (high-frequency), and differential global positioning system (DGPS). Detailed guidance on all aspects of hydraulic surveying to include these positioning methods is found in USACE Engineer Manual 1110-2-1003, Hydrographic Surveying (USACE 1991). Estimated positional accuracy for each of the electronic positioning systems is shown in Table 4.

Taut-moored buoys

Taut-moored buoy positioning requires locating and placing a buoy anchored and moored in such a way as to minimize buoy movement during placement operations. At USACE New England Division¹ disposal sites in 20- to 25-m depths, the taut-moored buoy has a watch circle diameter of about 20 m. Positioning of dredged material placement equipment is specified to occur within some distance of the buoy during disposal. Electronic placement errors are minimized with this method (except for initial

¹ The New England Division has been changed to the New England District.

**Table 4
Accuracy of Common Positioning Systems (from USACE
EM 1110-2-1003)**

Positioning System	Estimated Accuracy, Meters RMS
Range-azimuth	0.5 to 3
LORAN-C (low-frequency)	50 to 2,000
Microwave (high-frequency)	1 to 4
GPS	50 to 100
DGPS	0.1 to 1.0

buoy placement), and the exact dredged material placement location is subject only to the tug or dredge captain's discretion of buoy offset distance. Placement offset from the buoy depends on local weather and safety concerns. Specific guidance varies from site to site, but the New England Division has found success with specifying placement within 25 to 50 m of buoy location depending on weather/sea conditions. Experience has shown that this type of placement tends to concentrate material at one point or in a transect along the direction of travel of the tug and barge. This factor should be taken into consideration in buoy placement or in placement specifications for tug operators.

Range-azimuth

Range-azimuth positioning is a traditional surveying technique where a shore-based station (transit, theodolite, or total station) is used to determine an angular azimuth to the vessel of interest. This azimuth is then coupled with an electronically determined distance obtained from an electronic distance measurement (EDM) device (microwave EPS, laser EDM, or infrared EDM) at the same location. Range-azimuth positioning is very accurate, but because of the shore station requirement, it is applicable only at sites where dredged material placement is relatively close to shore (USACE EM 1110-2-1003). Range-azimuth positioning has been used by the Seattle District for several capping projects, e.g., the Duwamish Water project in 1984 (Truitt 1986b) and the Denny Way project (Sumeri 1989).

Electronic positioning systems (EPS)

Generally, the higher the frequency is of EPS, the more accurate the positioning. LORAN-C is a low-frequency, time-differencing hyperbolic phase/pulse system that triangulates vessel position based on relative distances from shore-based stations. Because LORAN-C is a low-frequency system, it has a low accuracy and is the least desirable for vessel positioning. For hydrographic surveys, LORAN-C is only suitable for Class 3 surveys (reconnaissance level), and absolute accuracy without onsite cali-

bration is 0.25 mile (USACE EM 1110-2-1003). Therefore, LORAN-C is not recommended as the sole navigation and positioning system for a capping project, and its use with other systems (e.g., a taut-moored buoy) should be thoroughly scrutinized. Some of the earlier less than fully successful capping projects conducted by the New England Division, where the initial cap did not fully cover the contaminated sediments, were due in part to problems with LORAN-C (SAIC 1995a). High-frequency systems (particularly UHF and microwave) are more commonly used for positioning offshore vessels. In general, operating distances are limited to radio line of sight, which allows use in riverine, harbor, and coastal locations (USACE EM 1110-2-1003).

The most accurate positioning system and rapidly becoming the standard for horizontal positioning is the satellite-based global positioning system (GPS). The NAVSTAR GPS is a real-time, passive satellite-based navigation system operated by the U.S. Department of Defense. The 24 GPS satellites orbit the earth such that from any place on earth at any time, at least four (the minimum required by the GPS receiver for positioning) are visible above the horizon. Standard GPS accuracies (50 to 100 m with DoD selective availability) are not ideal for capping operations. Increased accuracies can be obtained with differential GPS (DGPS). DGPS uses the same NAVSTAR GPS satellite system but requires two receivers with precise coordinates of one of the receivers known (usually a fixed land-based receiver). Accuracies of DGPS range from 0.1 to 1.0 m (USACE EM 1110-2-1003) (Hales 1995).

Kinematic DGPS is an additional refinement of DGPS that can provide accuracies of a few centimeters (USACE EM 1110-2-1003) and thus can eliminate the vertical datum problem that often occurs in the open ocean.

Kinematic DGPS is not yet routinely available, but the rapidly advancing GPS market may soon make its use commonplace. One of the more severe limitations of kinematic DGPS is the need to have the fixed shore station within 12 to 20 km of the surveying platform. However, industry advances will likely extend this distance.

An additional factor that should be considered in barge positioning is the placement of receiving/transmitting equipment on the barge or vessel. For instance, when a barge is being towed to the disposal site by a tug, there may be significant offsets between actual material disposal location and positioning antennae. If the positioning antennae is located on the tug, then the recorded placement location may differ by as much as 200 m from the actual placement due to offsets from the positioning antenna on the tug to the center of the barge. In addition, there may also be lateral offsets from the vessel track line that are on the order of a barge width. Therefore, for most capping projects where placement location is critical and will be recorded, it is recommended that the antennae be located on the barge. To be most effective, the GPS requires a visual display in the vessel's pilot house to accurately navigate and position the vessel.

Placement Options, Restrictions, and Tolerances

Several options are possible for placement of materiel using hopper dredges, barges, or pipeline dredges, depending on the particular needs for the project. These include stationary placement, placement at multiple points or along multiple lanes, or options aimed at spreading materials over large areas.

Stationary placement

Stationary placement is where the tug/barge or hopper dredge comes to essentially a complete stop for disposal. This method is ideal for concentrating the material to minimize mound spread. Dredged material will settle to the bottom without the imparted vessel velocity and associated turbulence and thus reduce total mound coverage. On its capping projects, the New England District has specified that the dredged material be placed while the barge is stationary or moving at less than 2 knots. The disadvantage of this method is the loss of vessel control by the operator during placement. Most operators prefer some forward movement of the vessel, particularly if waves, winds, and/or currents are strong enough to affect positioning. Vessel speeds up to 2 to 3 knots are preferred in the open ocean. However this scenario will increase the mound spread as the material is released over a greater area. In some cases this greater spread may be desirable to prevent creation of too much relief or to spread material evenly over a larger disposal area.

The time required for material to exit a barge or hopper should also be considered when specifying stationary or moving placement. Material exit time depends on the barge opening width, time to open, and type of material being placed. In general, barges open in 20 to 60 sec to a width of approximately the bin width. Barge modifications (including installation of false sides) can be made to effectively increase the opening width/bin width ratio thus facilitating material exit, though this is an extreme (and costly) modification. Typically, sandy material will exit the barge in 30 sec to 2 min, and fine-grained material will take 10 to 30 sec to exit. For split-hull hopper dredges, exit time can take from 3 to 5 min for sandy material, with fine-grained material exiting in roughly 30 sec, with silty sand mixtures exiting in about 2 to 5 min. Hopper dredges with doors and pocket barges require longer times for the material to exit. For example, the STUYVESANT (industry hopper) has 20 hopper doors, and sandy material takes approximately 5 min to exit (Sanderson and McKnight 1986).

An often encountered problem during the disposal phase is that as the hull is opened and material begins to exit the barge, some material will form a bridge across the hull opening and thereby reduce the rate of discharge. Additionally, the material may bridge to the extent that it will not fall until the hull has opened beyond the angle of repose of the material. When this occurs, this bridged material can discharge quickly and exit the barge with a large initial velocity. The net effect can be an increased

impact velocity on the bottom, which may displace previously placed material (Parry 1994). Additional discussion of this phenomena is provided later in this section. Bridging of sand over the hull opening is typically much less of a problem in modern hopper dredges that have water cannons in the hoppers to help fluidize the sand.

Barge towing and positioning are generally a factor of weather conditions. In good weather, barges may be transported and positioned with a tug directly alongside. This allows for more precise dump positioning. Also, if the barge is under tow, the line length may be as short as 30 or 45 m with lateral offsets on the order of one barge width. In poor weather, the tow length may be increased to 175 to 300 m where lateral offsets may be several barge widths.

For even placement of material around a point, vessel approach headings should be varied. Vessel operators generally prefer to approach the disposal site from the direction of travel to the site because that direction affords the shortest time to travel and dispose. However, continuous dumping along one transect may concentrate material in a manner or location that is less than ideal for the capping project. When weather permits, approach direction should be specified so that the most even coverage of dredged material can be accomplished. But, for poorer weather conditions, operators should be afforded the flexibility to approach the placement area from the safest direction based on the prevailing winds and waves at that time.

Use of multiple disposal points or lanes

For large projects (say 100,000 to 200,000 m³ or more) in shallow water (say 20 m and less), point dumping of contaminated material at a single location may create a mound unacceptably tall. To avoid this, placement can be divided among multiple buoy locations to create a larger (footprint) but less thick mound. This was done for the 1993 New Haven Harbor Project (Fredette 1994). The other option is to place material along a line or in lanes. For example, the 1993 Port Newark/Elizabeth project had an EPA Region II restriction not to have the capped mound extend above the 23-m (75-ft) depth contour. Because the existing depth averaged about 25 m (83 ft), point dumping the 448,000 m³ (586,000 yd³) of contaminated dredged material would have created a mound extending well above the 23-m depth restriction. To keep the mound elevation below the limit, a triangular mound was designed, with three lanes with a width of 150 m (500 ft) wide by 350 to 450 m (1,150 to 1,480 ft) long (see additional discussion in Chapters 6 and 10). To assist the contractor in siting the placements, each apex of the triangle had taut-moored buoys. To reduce the chance of placing material outside the lanes, the contractor was directed to dispose of all material within 60 m (200 ft) of an imaginary line connecting the apex buoys. Additional details on this project can be found in Chapter 10.

For capping projects, both point dumping and spreading material over specific lanes have been used, sometimes both on the same project. For small projects (say 25,000 m³ or less) where the contaminated sediment

mound was created by point dumping at a taut-moored buoy, the New England District will place the majority (say 65 to 70 percent) of the capping material in similar fashion. However, the capping material is placed within 50 to 75 m of the buoy as opposed to the 25-m limit used for the contaminated material. The remaining 30 to 35 percent of the material is spread around the outer edge of the mound, say 100 to 150 m from the buoy.

Spreading over large areas

For larger projects, a series of specific lanes can be defined to spread the capping material. This technique is generally used when the sand is sprinkled. The sprinkling can be accomplished by cracking the hull of the barge or split-hull hopper dredge or by direct pumpout from a hopper through over-the-side pipes. The most straight-forward method to determine lane spacing for the cracked-hull technique is to compute the footprint from an individual load using either the Multiple Dump Fate of Dredged Material (MDFATE) or Short-Term Fate (STFATE) model (see Chapter 6 and Appendixes D and E). Of interest will be the footprint's maximum thickness, maximum width, and width at 0.5 the maximum thickness. Table 5 shows the results of MDFATE runs used to design the capping operation for the Port Newark/Elizabeth project. Based on this information, disposal lanes 30 m (100 ft) wide, or approximately equal to the maximum width of the footprint predicted by the model lanes, were

Table 5
Summary of Modeling Results for Capping Contaminated Sediments Using the Split-Hull Hopper Dredge Dodge Island and Hopper Barge Long Island

Disposal Type	Dredge Speed m/s	Disposal Time min	Maximum Thickness, cm	Maximum Width m	Width at 0.5 Max Thickness, m
Split-Hull Hopper Dredge Dodge Island					
Cracked hull	1.54	20	4.3	32.0	18.3
Cracked hull	1.54	30	2.7	32.0	18.3
Cracked hull	1.03	20	6.4	41.0	18.8
Cracked hull	1.03	30	4.3	32.0	18.3
Hopper Barge Long Island					
Counterflow	0.51	120	7.3	155.4	64.0
Counterflow	1.03	120	3.0	155.4	82.2
Counterflow	0.51	180	4.9	137.2	64.0
Counterflow	1.03	180	2.0	137.2	82.2
Counterflow	0.51	180	4.9	137.2	64.0
Counterflow	1.03	180	2.0	137.2	82.2

selected for the split-hull hopper dredge Dodge Island, which started the capping operation with the goal of quickly covering the contaminated mound with 15 cm (6 in.) of sand cap. Variations in the vessel's track line down the lane were expected to spread the material evenly over the area. Sediment profile image (SPI) profiles (see Chapter 9) at a spacing of a 5-m run perpendicular to the lanes conducted after a few passes had been made showed no area without sand and most areas to have a 15-cm (6-in.)-thick cover, apparently confirming the model predictions. Lanes 75 m (250 ft) wide were selected for the hopper barge Long Island. This value is about equal to the width at 0.5 of the maximum thickness. The majority of the cap was placed with the Long Island. See Chapter 10 for additional details on this project.

Several factors have to be considered when using disposal lanes for cap placement. Hopper dredges have superior seakeeping abilities compared with towed barges and thus will be better suited to open-ocean placement. Towed barges for lane disposal probably should be restricted to protected areas. When the cracked-hull technique is used, once the hull is cracked it cannot be closed until the vessel is empty. Thus, when the vessel reaches the end of a line, it continues to discharge cap material while turning. So, to reduce the spread of cap material beyond the contaminated footprint, the vessel should turn before reaching the edge of the contaminated material. It is likely more effective to cap the outer edge of a contaminated mound using a series of straight segments around the perimeter of the footprint. Also, while a vessel that is using direct pump-out to discharge material can stop the pump during turns, the dredge operators would much prefer to keep pumping. Thus, similar considerations will have to be made regarding where the turn is conducted.

Turning radius is another factor that needs to be considered for cap placement using disposal lanes. Modern hopper dredges have bow thrusters and can turn in less than their own length; therefore, they can often proceed down adjacent disposal lanes. Older hopper barges and less maneuverable hopper dredges have larger turning radii and therefore may only be able to cap every 2nd or 3rd disposal lane. This is not a problem, but requires more accurate record keeping to confirm no lanes are missed. The decision on how the dredge or barge is operated, i.e., adjacent lanes, or every 2nd, 3rd, 4th lane, etc., should be made in consultation with the operator. Keeping a record of track plots is highly recommended. In protected waters, a 1,000-m³ towed hopper barge needs about 120 m to turn while maintaining speed and control (Parry 1994). Because of individual variations between vessels, it is prudent to consult with the vessel operators early on in the process to obtain the best estimates of sea-keeping abilities turning radii, etc.

How long it takes to discharge the capped material is another factor to be considered for cap "sprinkling." When the Dodge Island cracked its hull 0.3 m (1 ft) during the Port Newark/Elizabeth project, the 2,000-m³ (2,600-yd³) load of sand exited in 20 to 30 min, translating to a rate of 65 to 100 m³/min. During direct pump-out, the Long Island emptied its roughly 9,600-m³ load in 2 to 3 hr, translating to a discharge rate of 53 to 89 m³/min. Hopper dredges can use their water cannons to produce reasonably continuous discharge rates. In fact, they can turn off their water cannons to reduce the discharge rate during turns.

Conversely, it is much more difficult to control the rate sand is discharged from a split-hull barge. Based on the Seattle District's experience using split-hull barges to place caps, Parry (1994) recommends discharge rates of 30 to 42 m³/min to reduce the size of the end pulse caused by bridging to about 5 percent of the load. At higher discharge rates, say 600 m³/min, Parry (1994) notes that the size of the pulse can be up to 33 percent of the total load. Nelson, Vanderheiden, and Schuldt (1994) report discharge rates of 41 to 70 m³/min using a split-hull barge at the Eagle Harbor in situ capping project.

Controlling and monitoring extended discharge from a split-hull barge is a nontrivial matter. The small barges, typically about 1,000 m³ used by the Seattle District, are opened 6 to 8 deg to start sand flowing. Discharge rate can be monitored by change in draft measured by pressure sensors radio linked to a display on the tug, and with experience it can be done visually. As the load is lightened, the barge has to be opened more to continue a constant flow of sand.

Inspection and Compliance

Proper tracking of dredged material placement prior to capping includes adequate records of barge position, environmental conditions, vessel headings and velocities, start/end times of discharge, and load/draft of barge. In most cases, dredging contractors keep records detailing much of this information in their dredge logs.

The information from the inspector's or contractor's logs can be useful in identifying volumes of material placed, locations of placement, and correlation of material placement with hydrographic survey results. Dredge logs can also be the primary source of information for locating material that is short-dumped. Short-dumping can result for various reasons including human error, inadequate positioning information, malfunction of electronic positioning instruments, and safety. When material is short-dumped, it usually ends up outside of the specified disposal site, and postdisposal survey information may be limited or nonexistent. However, the dredged material must still be capped, and the more information that is available (from dredge logs), the better the capping job that can be done. In one instance on the Port Newark/Elizabeth project, a short dump of one barge load of material (2,300 m³) was covered with 31,000 m³ of cap material because of a substandard positioning system (LORAN-C), lack of knowledge of the tug/barge offset (the antenna was on the barge not the tug), and incomplete records.

Dredged material placement inspection can be conducted by onboard personnel provided by either the USACE District or dredging contractor. Many USACE dredging projects already require onboard inspectors to document proper dredging location, volumes dredged, and appropriate depths attained. For capping projects, both the New England Division and the New York District use inspectors. New England Division inspectors are contractors (but not employees of the dredging company). The New York District uses Corps employees as inspectors.

A new technology for dredging inspection that is being implemented is the Silent Inspector (SI). The SI uses state-of-the-art computer hardware and software to measure multiple dredge state parameters and provide output to automatically create USACE dredging reports. At this time, the SI is most readily applied to hopper dredges. Future work involves developing similar automatic inspection systems for hydraulic pipeline and mechanical dredge types. Many types of information are recorded by the SI including vessel speed, heading and position, hopper door status, vessel draft, and water depth. For capping projects that use hopper dredges, the SI can provide much of the needed information from dredging throughout placement (Cox, Maresca, and Jarvela 1995).

SI technology has also been applied to dredged material placed from a barge. A data logger on the barge records position and draft (from a pressure sensor). When the barge doors or hull are opened, the change in draft and location are recorded. The data can be downloaded to a computer at a later time or broadcast via radio link to a shore station for real-time monitoring. Commercial systems are available, and the New England Division has also provided some custom systems to the Districts. Both the Seattle and San Francisco Districts have used this type of system to monitor placement of dredged material.

During the placement of dredged material, periodic hydrographic surveys may be desirable to track mound growth. These surveys can allow the project manager to make midcourse adjustments in placement operations to effect changes in mound heights (either greater or less). Track plots from dredge logs or placement positions provide good information for long-term project placement locations.

Weather plays an important role in placement of dredged material not only for barge positioning but also in exposing the dredged material mound to unwanted erosion. As with most dredging projects, capping projects should be conducted in the less energetic summer months. During this time of year, storms are usually less frequent, thereby reducing the near-bottom currents that tend to move bottom sediments. For capping projects, this is particularly important to prevent the spread of contaminated material. Therefore, capping projects should afford adequate time for contaminated material placement and cap material placement to be conducted prior to the onset of fall/winter storms. Contingency plans that include phased capping or staging cap material for easier postconstruction placement should be considered for areas that are susceptible to hurricanes or other summer storms.

6 Sediment Dispersion and Mound Development and Site Geometry During Placement

The physical behavior of a dredged material discharge depends on the type of dredging and disposal operation used, nature of the material (physical characteristics), and hydrodynamics of the disposal site. For capping operations, it is essential to determine beforehand the nature of the discharge for both contaminated and capping material. The degree of dispersion and associated water column contaminant release dictates whether a given discharge is acceptable from the standpoint of water column impacts. The geometry of the subaqueous deposit or mound dictates the required area to be capped and cap configuration.

Sediment Dispersion During Placement

A knowledge of the short-term physical fate of both the contaminated material and capping material is necessary to determine the acceptability of the equipment and placement operation under consideration. Short-term fate is defined as the behavior exhibited by the material during and immediately following discharge. The dispersion of material released into the water column and the deposition of the material on the bottom are also of interest. These processes occur over a time period of a few minutes to several hours for a single release from a barge or hopper dredge.

In addition to physical dispersion of suspended material, an evaluation of water column mixing of released contaminants or suspended dredged material is necessary whenever potential water column contaminant effects are of concern. Such an evaluation may involve comparison of predicted water column contaminant concentrations with water quality criteria (or standards) or predicted suspended dredged material concentrations with bioassay test results. Water column effects measured in the field on actual projects may be valuable in quantifying water quality effects. For capping operations, such evaluations are normally required for the contaminated material to determine if water column control measures

(i.e., submerged discharge) are necessary during placement. In addition, the prediction indicates what portion of the contaminated material is dispersed during placement and is not capped.

Methods for evaluation of potential water-column contaminant release are available ((USACE/EPA 1992). The contaminant release is predicted by an elutriate test, and results are compared with applicable water-quality criteria or standards as appropriate. In addition, acute water-column toxicity bioassays considering initial mixing may be needed. The procedures to be used in elutriate or water-column bioassays are provided in the MPRSA and CWA testing manuals (EPA/USACE 1991; EPA/USACE 1998). For disposal operations under the MPRSA, specific criteria for water quality and water-column toxicity must be met, and specific allowances are specified for initial mixing (EPA/USACE 1991). For disposal operations under CWA, water quality and water-column toxicity standards and allowances for initial mixing are specified by the States as a part of the Section 401 water-quality certification requirements.

The physical development of a mound or deposit on the bottom due to a number of barge or hopper releases or prolonged discharge from a pipeline is also of interest. Such information can be used to define the areal extent of the mound or deposit for the contaminated material. This dictates the required volume of capping material.

A computer model is available for evaluating the short-term fate of dredged material discharges in open water from hoppers or barges. The model is called the Short-Term FATE (STFATE) model (Johnson et al. 1993; Johnson and Fong 1995) and can be run on a personal computer (PC). This model is available as a part of the Automated Dredging and Disposal Alternatives Management System (ADDAMS) (Schroeder and Palermo 1990). Versions of the model are also included in the Ocean and Inland testing manuals (EPA/USACE 1991; EPA/USACE 1998). Appendix D describes the STFATE model in greater detail.

Input data required to run the model include (a) description of the disposal operation, (b) description of the disposal site, (c) description of the dredged material, (d) model coefficients, and (e) controls for input, execution, and output. More detailed descriptions and guidance for selection of values for many of the parameters are provided directly on-line in the system software or default values may be used.

Model output includes a time history of the descent and collapse phases of the discharge and suspended sediment concentrations for various particle size ranges as a function of depth and time. At the conclusion of the model simulation, the thickness of the deposited material on the bottom is given. Examples of model output are given in Figures 12 and 13. This allows an estimate of the areal extent or “footprint” of contaminated material as deposited on the bottom for a single disposal operation (i.e., a single barge or hopper load of material).

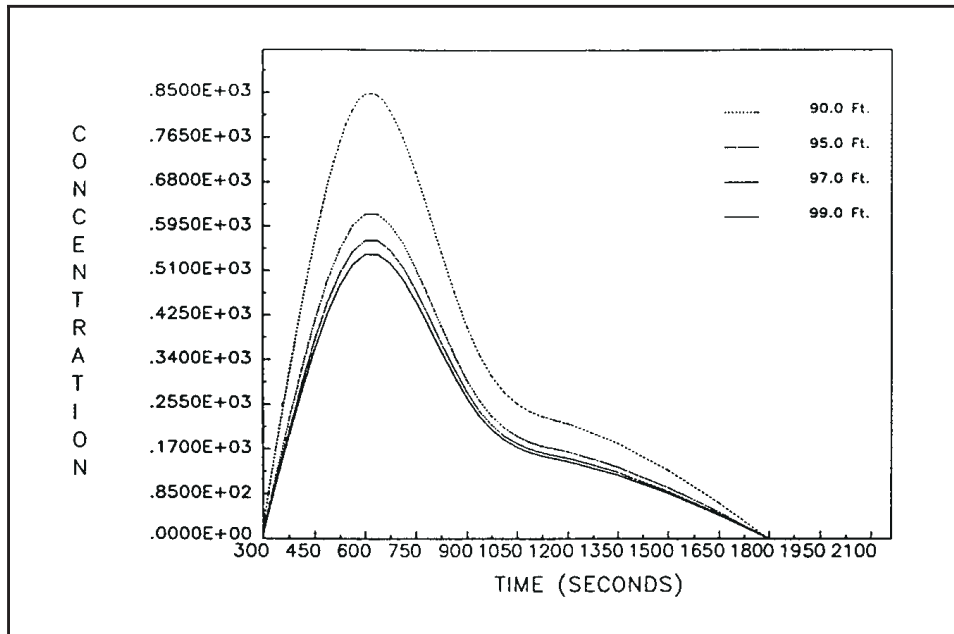

Figure 12. Typical STFATE model results showing concentration above background of clay (mg/l) (from Johnson 1992)

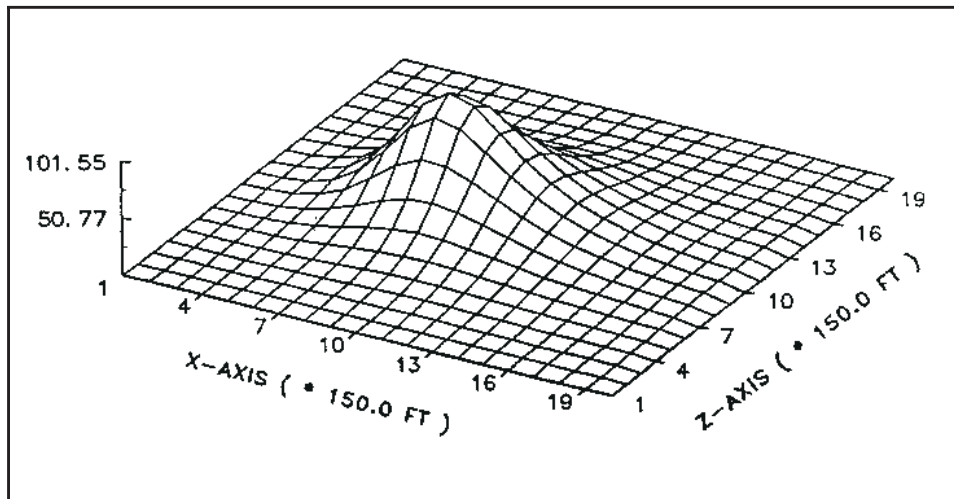

Figure 13. Typical STFATE model results showing total volume ($\text{ft}^3/\text{grid square}$) of new material (from Johnson 1992)

Evaluation of Spread and Mounding

The mound or deposit geometry, including contaminated material and cap, will influence the design of the cap and volume of capping material required. The smaller the footprint is of the contaminated material as placed, the less volume of capping material will be required to achieve a given cap thickness.

For LBC sites, the geometry of the contaminated material mound depends on the physical characteristics of the material (grain size and cohesion) and the placement technique used (hydraulic placement will result in greater spread than mechanical placement). Assuming that the material from multiple barge loads or pipeline can be accurately placed at a single point, the angle of repose taken by the material and the total volume placed will dictate the mound spread.

However, few data are available on the volume changes resulting from entrainment of water during open-water placement or the shear strengths of dredged material initially deposited in open-water sites. For these reasons, a priori estimates of mound spread made to date have been made based on the observed characteristics of previous mounds created with similar placement techniques and similar sediments (Palermo et al. 1989).

Models have been developed that will account for the development of mounds due to a number of barge or hopper discharges (Moritz and Randall 1995; SAIC 1994). The Corps' mound building model that models Multiple Disposals from barges and hopper dredges and their FATE (MDFATE) is a modification of the STFATE model. In the MDFATE model, a streamlined version of the STFATE model is run for each barge disposal. Thus, the input requirements for MDFATE are similar to those for STFATE. In MDFATE, the program keeps track of the mound thickness in each grid cell, then algebraically adds the thickness from subsequent disposals with avalanching when mound steepness exceeds critical values. MDFATE allows a number of typical disposal patterns to be automated; it allows moving barges and can import actual site bathymetry in real-world coordinates. MDFATE also allows interaction with the LTFATE model (Scheffner et al. 1995). This allows the mound created in MDFATE to be eroded by waves and currents during mound creations that may last months. A more detailed description of MDFATE can be found in Appendix E, and a more detailed description of LTFATE can be found in Appendix F.

Similar to the output from STFATE, output from the MDFATE model includes the volume of material on the bottom and contour and cross-section plots of mound bathymetry. Figures 14 and 15 show typical MDFATE output. One limitation of MDFATE is that it has been verified on only one actual project to date (Moritz and Randall 1995).

A model developed for the New England Division Disposal Area Monitoring System, the DAMOS capping model (Wiley 1994), is also based on the STFATE model. While it does not consider moving vessels or erosion by waves and currents, it has the advantage of having been verified for a number of mounds constructed by the New England Division in Long Island Sound.

Typical Contaminated Mound Geometry

As noted in the previous chapter, for LBC projects, virtually all of the mounds created have been constructed using mechanical dredging with transportation and placement by bottom-dump barges. The resulting

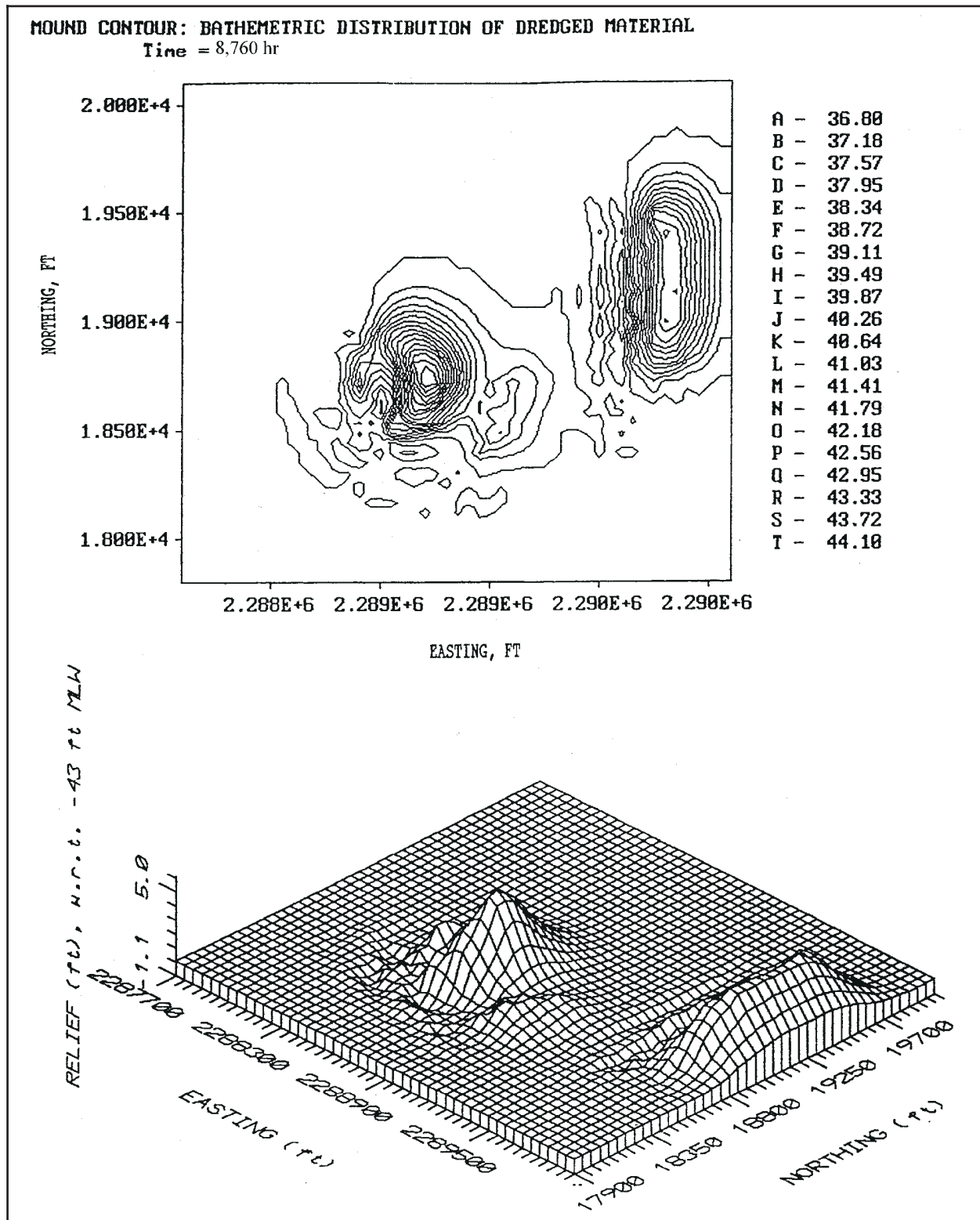

Figure 14. Typical MDFATE model output showing differences between predisposal and post-disposal bathymetry

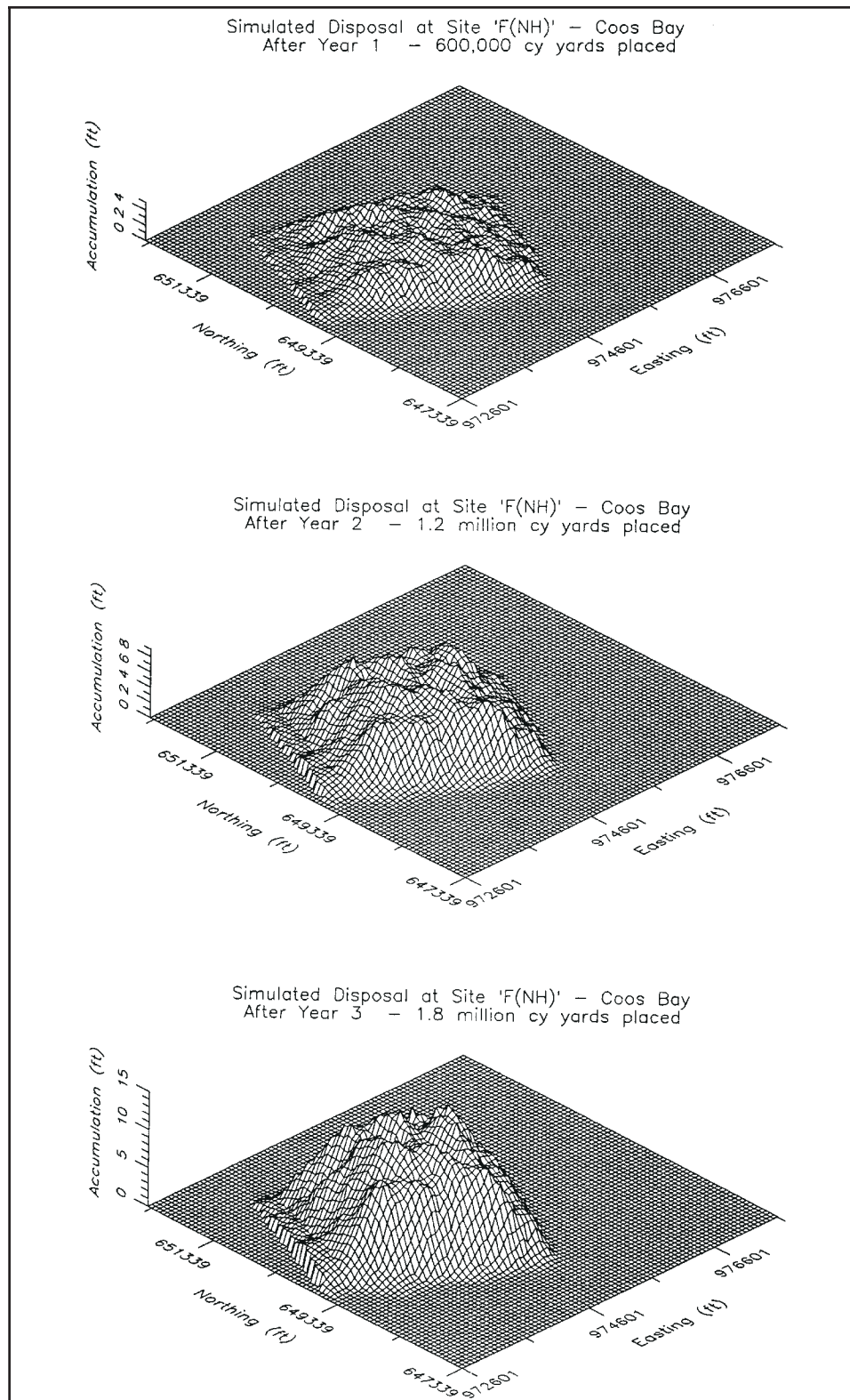

Figure 15. Typical MDFATE model output showing mound formation 1 to 3 years of disposal at Coos Bay

mounds created have had reasonably consistent geometries. Most mounds have been round or elliptical in shape, with a defined crest that is relatively flat, a main mound side slope (also termed the inner flank), sometimes an outer flank, and a thin outer apron. Figure 16 shows a generic contaminated mound. The dimensions for the side slopes and apron widths are based on those seen at the Port Newark/Elizabeth mound created in the Mud Dump site in 1993. The following paragraphs describe each of the mound features in more detail.

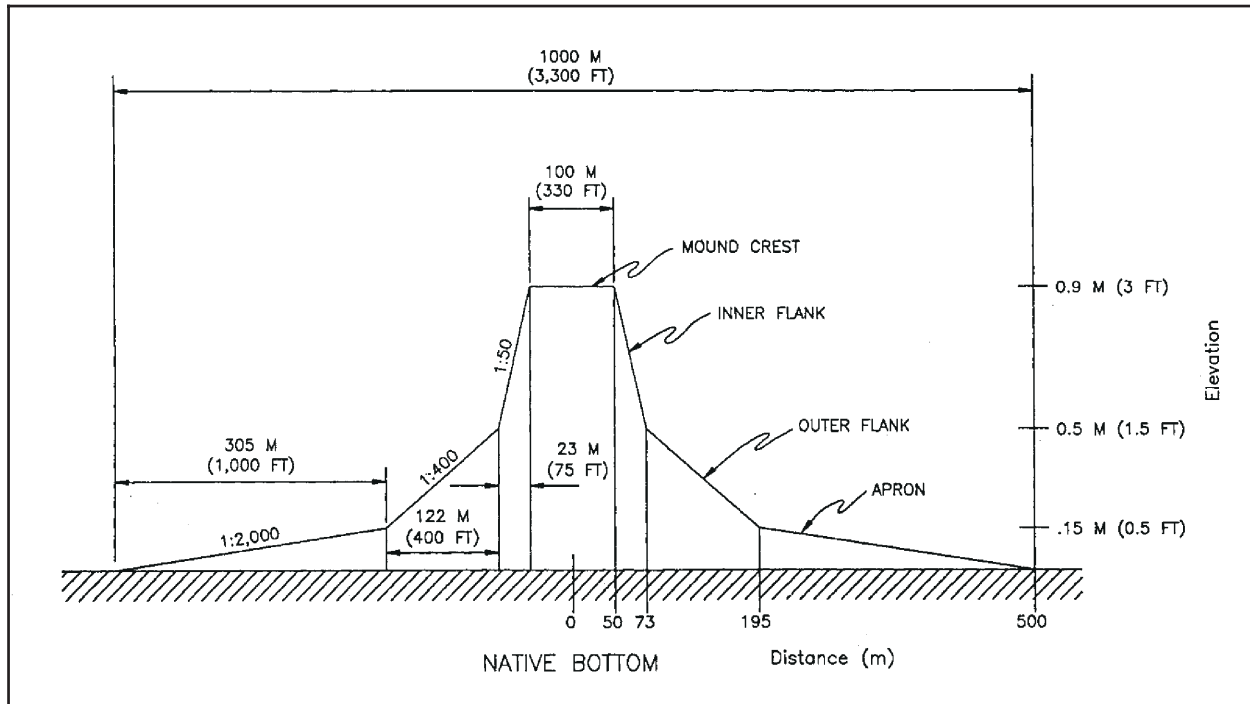

Figure 16. Typical mound geometry

Mound crest

Most contaminated mounds to date have had main mound crest elevations of 1 to 2 m, though some contaminated mounds with elevations of 3+ m have been constructed. Higher mounds have been constructed from noncontaminated material. For point-dumped projects in the New England Division, mound crests have generally been circles or ellipses approximately 100 to 200 m in diameter, reflecting good control of the disposal process around a taut-moored buoy (disposal within about 25 m of the buoy), for moderate-sized projects, generally 20,000 to 100,000 yd³. The 1993 Port Newark/Elizabeth project used disposal lanes, 150 m in width and 300 to 420 m long, to create a triangular-shaped mound, approximately 630 by 645 m, with peak elevations of 1.5 to 2.4 m.

Inner flank

At the edge of the main mound, the inner flank of the mounds slope downward at a slope of approximately 1:35 to 1:70 with most of the mound slopes between 1:35 and 1:50. For the Port Newark/Elizabeth mound, the inner flank extended from the mound crest down to an elevation of about 1.0 m above the preplacement bottom.

Outer flank

For the Port Newark project, a break in slope generally occurred at the 1.0-m elevation; the outerflank then sloped down to an elevation of about 0.30 to 0.15 m at a slope of about 1:115. Data from the New England Division projects have not been examined in sufficient detail to determine if a similar feature exists for those mounds.

Apron

During the dynamic collapse phase (when the energy of the vertically descending jet of material disposed from a barge or hopper dredge is converted to horizontal velocity), some portion of the low shear strength, fine-grained material with high water contents may be transported a considerable distance from the disposal point. At the completion of the contaminated material placement, an apron of fine-grained material, typically 1 to 15 cm in thickness but extending up to several hundreds of meters beyond the main mound flanks, has occurred on almost all LBC projects. The apron has been defined as that portion of the material less than about 15 to 30 cm in thickness, because 20 to 30 cm is the resolution limit for high-quality bathymetry in water depths of 25 m or less.

A sediment profiling camera (SPC) can reliably measure apron thickness from 1 to 2 cm up to 20 cm. Thus, the outer limit of the apron should be defined as the point at which the apron can no longer be conclusively distinguished by the SPC, a thickness of 1 to 2 cm. Some contaminated material extends beyond the apron edge as defined by the 1- to 2-cm SPC limit; however, the percentage of the total volume is likely extremely small.

The apron typically exhibits an overall slope of $1v:1000+h$ at the Port Newark/Elizabeth project, and overall apron slope of about 1:2,000 was observed on downward sloping bottoms. If the inner edge of the apron is assumed to be 15 cm in thickness, the width of the apron for the Port Newark/Elizabeth project was about 300 m. The STFATE model and MDFATE model and the DAMOS capping model can be used to predict the apron dimensions.

Recent experience with a New York District 1997 capping project placed in the Mud Dump site illustrated the potential for slope adjustments when fine-grained mounds are created with heights exceeding about 10 ft. In one case, a portion of a contaminated mound with a height of 12 ft had a slope adjustment resulting in an after adjustment height of 6 to

8 ft and a movement of material outward of about 1,000 ft. This section of mound was placed on an ambient slope of up to 1.45 deg, which likely contributed to the adjustment and the outward movement. In a second case, a portion of the same mound with an elevation exceeding 10 ft experienced an apparent slope adjustment after capping began. Losses in elevation of 3 to 4 ft occurred as a result of the adjustment, though the significant outward movement seen on the uncapped section did not occur. This section of the mound was placed on a nearly flat slope. The above illustrates the need to consider the potential for slope adjustments in mounds over 6 to 8 ft tall. Analysis of slope stability for taller mounds, particularly those placed on slopes, is recommended (Moritz 1997).

Mound Geometry for Level-Bottom Capping

Evaluation of contaminated material mound geometry for an LBC project requires a series of steps:

- a. **Determine volume of material to be disposed.** The first step in a capping project is to compute the volume of contaminated material to be dredged. An accurate estimate of the volume of contaminated material to be dredged should be a fairly straightforward process. Normally computer programs that compare authorized channel dimensions with existing bathymetry determine the volume of material to be dredged, with a combination of core, subbottom profiler, and sediment chemistry and bioassay/bioaccumulation testing done to determine the volume of contaminated sediments. The designer should consider including possible overdepth in the volume calculation. Normal clamshell allowed overdepth is about 2 ft. Some of the “environmental” clamshells claim lower overdepths 6 in. to 1 ft. Very high-quality instrumentation in addition to a special bucket is needed to achieve the lower overdepth values.
- b. **Bulking.** Some bulking of the sediments during the dredging process may be factored into computing the volume required for capping. For mechanically dredged sediments, bulking of 10 to 20 percent (Herbich 1992) is reasonable. For materials dredged by hopper, a large volume of excess water is initially stored in the hopper, but the volume of water may be reduced prior to material placement by overflow. Following placement by hopper, a large portion of the excess water is almost immediately expelled from the material as it settles to the bottom.

In most instances capping will involve mechanical dredging of maintenance material with relatively low densities. These materials can experience fairly rapid consolidation. Most contaminated dredged projects will require several weeks or longer to conduct dredging. Thus, by the time capping is ready to begin, some consolidation will have taken place such that the volume to be capped may be nearly the in situ volume. Without site-specific data, a net bulking volume (including the apron) of 10 to 20 percent is reasonable.

- c. **Predict contaminated mound geometry.** An accurate prediction of contaminated mound geometry is one of the most critical steps in LBC project design. There are two primary methods to determine mound geometry ranging from fairly simple to complex. The simple method is to assume a basic shape (e.g., a truncated cone or rectangular prism with sloping sides), then estimate side slopes and an apron width. A spreadsheet is an effective method to test a range of expected heights and crest dimensions on footprint dimensions and the corresponding cap volume required. A more rigorous method is to use a numerical model such as the MDFATE model (Moritz 1994; Moritz and Randall 1995) to predict mound geometry. Use of a numerical model allows the user to investigate the impact of changing operations (disposal pattern, barge size, barge velocity, etc.) on mound geometry.
- d. **Is the calculated contaminated mound geometry suitable?** After the contaminated mound footprint and elevation have been calculated, the project manager/designer must decide if the predicted contaminated mound geometry meets project needs. The two basic concerns are as follows: Will all the contaminated material (and cap material) stay within any surface area constraints? Is the elevation of the capped mound sufficiently low so as not to interfere with navigation and not experience excessive erosion? A reasonable buffer distance between the edge of the contaminated mound and the site boundary is 100 to 200 m. If the answer to both questions is yes, then the designer can proceed to the next step, computing cap volume required (described in more detail in Chapter 7 and Appendix H). If the contaminated mound is predicted to spread too near or over the site boundary or is too high, then the following options should be investigated.
- e. **Calculated contaminated mound footprint is too large.** If the contaminated mound footprint extends beyond the site boundary or is so large that the cost or volume of cap material required is a problem, several options are possible. Once again the simplest solution (but probably unattractive from the project perspective) is to reduce the volume of material being placed. One option to reduce spread is to make the mound taller by reducing the size of the area over which disposal takes place. The mound shape can be changed to make better use of available space; e.g., for the 1993 Port Newark/Elizabeth project conducted in New York District, a triangular-shaped mound was used. Figure 17 shows the rectangular mound dimensions in the original design and Figure 18 shows the triangular mound design modification. Other options include dredging pits and/or placing confining berms around the area (essentially creating a CAD) or using a diffuser to reduce spread. An operational change such as reducing the barge velocity, changing approach direction of the disposal vessels, or disposing only when the currents are in a favorable direction are other possible options. To evaluate such options will require using a numerical model.

Long-term planning can help to create a de facto CAD site. Over a period of several years, the New England Division made a series of small mounds around a portion of their Central Long Island

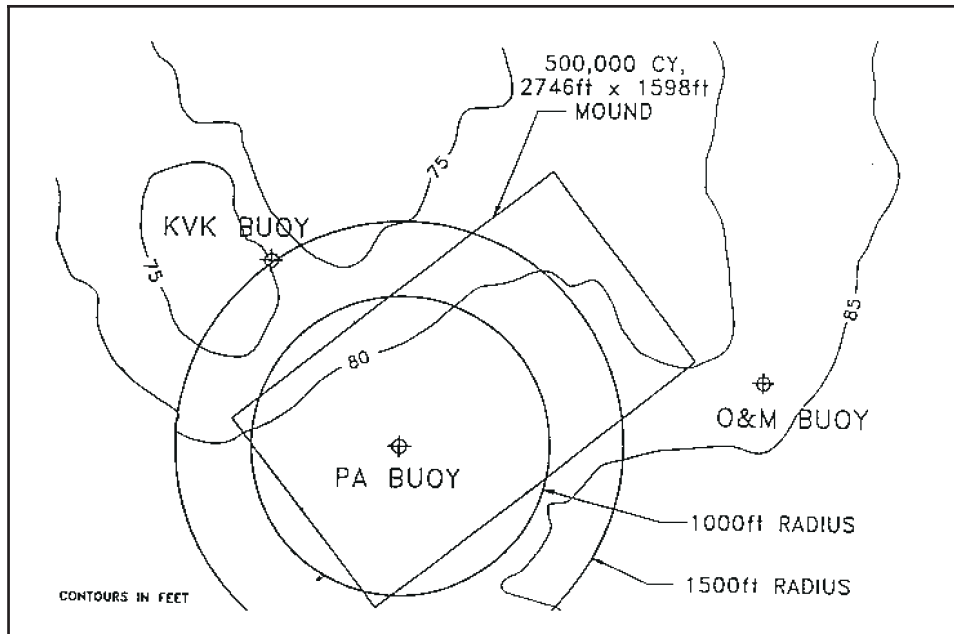

Figure 17. Original contaminated mound design for Port Newark/Elizabeth project

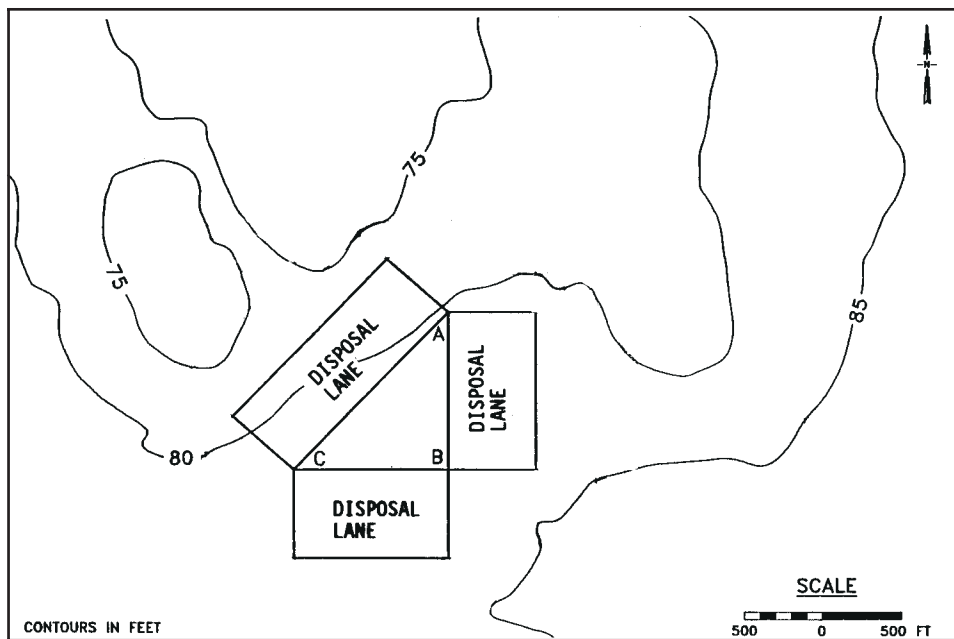

Figure 18. Disposal lanes used for triangular mound placement of contaminated material in Port Newark/Elizabeth project

Sound (CLIS) disposal site. This depression was then filled with over 500,000 m³ of contaminated sediments in 1993/94 from the dredging of New Haven Harbor. By confining the contaminated material within the series of mounds from the smaller projects, the spread of the contaminated material was greatly reduced, requiring

a relatively small volume of material to cap the contaminated sediments. Fredette (1994) describes the project in more detail.

- f.* **Calculated contaminated mound is too high.** If the calculated mound peaks exceed the maximum depth limit, it may be possible to increase barge velocity to make a mound of more constant elevation without substantially increasing the footprint. If much of the mound exceeds the minimum depth restriction, two obvious solutions are to (a) find a deeper portion of the site or another site (if available), or (b) reduce the volume of contaminated material. Perhaps a more feasible solution is to spread out the area of placement to reduce mound height. This will increase the surface area of the mound and thus the amount of cap required. It may also create problems with contaminated material coming too close to the site boundary. Another option is to consider a dredging method that increases the density of the contaminated material, a difficult proposition for mechanically dredged sediments.
- g.* **Cap geometry.** The same tools and approaches used for evaluation of contaminated mound geometry can be used to evaluate geometries for LBC caps. However, the major consideration for cap geometry is the placement of a layer of the required cap thickness over the central portion of the mound and over the apron as appropriate.

Geometry for CAD Projects

The geometry of the deposit for CAD sites is largely controlled by the geometry of the depression or subaqueous berms that form the lateral containment. If hydraulic methods are used to dredge the contaminated materials going into the CAD site, and if the site has a relatively small surface area, the materials will tend to spread in a layer of even thickness over the entire area. If the site has a large surface area, or if the contaminated material is mechanically dredged and placed by barges, the material may tend to form a mound within the site not covering the entire surface area. If this is the case, methods for intentionally spreading the contaminated material within the CAD site boundaries may be appropriate. Contaminated materials should be placed in CAD sites as a layer of uniform thickness, so that the required thickness of cap material can be placed using a minimum volume of cap material.

Cap geometry for CAD sites should be developed as the design cap thickness placed uniformly over the entire contaminated deposit. Assuming the contaminated material has been placed as a fairly uniform layer, the cap would essentially be placed from bank to bank within a depression, pit, or contained area formed by subaqueous berms.

The same tools as described above for LBC projects can be used for evaluation of deposit geometry for CAD sites. The major consideration for CAD geometry is the placement of both contaminated and cap layers in a uniform and level configuration.

Bulking is an important consideration for CAD geometry. The volume of contaminated material and cap and associated bulking must be closely estimated to ensure that all the material and cap can be placed within the available contained volume. For mechanically dredged sediments, bulking of 10 to 40 percent (Bray, Bates, and Land 1997) is reasonable. For hydraulically dredged sediments, dredged and placed by hopper or pipeline, much of the excess water will be expelled as the material is placed within the CAD site, but the volume occupied during the placement operation must be closely estimated. A project-specific investigation of the expected increase in volume for a particular dredging/placement method and sediment is warranted. Sedimentation analysis to determine a volume occupied by hydraulic pipeline placement to a CAD site has been conducted using procedures developed for diked confined disposal facilities (Averett et al. 1989). Procedures for such an analysis are outlined in detail in the USACE Engineer Manual 1110-2-5027, Confined Disposal of Dredged Material (USACE 1987).

7 Dredged Material Cap Design

This chapter presents procedures for designing subaqueous dredged material caps and a sequence for determining the design cap thickness components to account for bioturbation, erosion, consolidation, operational considerations, and chemical isolation. Methods for determining the required volume of cap material and design considerations for intermediate caps are also discussed.

General Considerations

The composition and dimensions (thickness) of the components of a cap can be referred to as the cap design. This design must physically isolate the contaminated sediments from the benthic environment and achieve the intended cap functions. The design must also be compatible with available equipment and placement techniques.

The composition of caps for dredged material projects is typically a single layer of clean sediments because relatively large volumes of cap material are involved; clean sediments from other dredging projects are often available as cap materials; and dredged material capping sites with low potential for erosion can be selected. Guidance on dredged material cap design in this chapter therefore focuses on the thickness of the cap as the major design criterion.

In contrast, in situ capping projects usually involve smaller volumes or areas; clean sediments are not always readily available as capping material; and site conditions are a given. For these reasons, caps composed of multiple layers of granular materials as well as other materials such as armor stone or geotextiles are often considered, and the in situ cap design cannot always be developed in terms of cap material thickness alone. Procedures for design of caps composed of nonsediment components are available in the EPA guidance document for in situ capping projects (Palermo et al. 1996).

Required Cap Thickness

Determining the minimum required cap thickness depends on the physical and chemical properties of the contaminated and capping sediments, hydrodynamic conditions such as currents and waves, potential for bioturbation of the cap by aquatic organisms, potential for consolidation of the cap and underlying sediments, and operational considerations. Total thickness can be composed of components for bioturbation, consolidation, erosion, operational considerations, and chemical isolation. Schematics of the cap thickness components and potential physical changes of the cap thickness due to erosion, consolidation, etc., are shown in Figure 19.

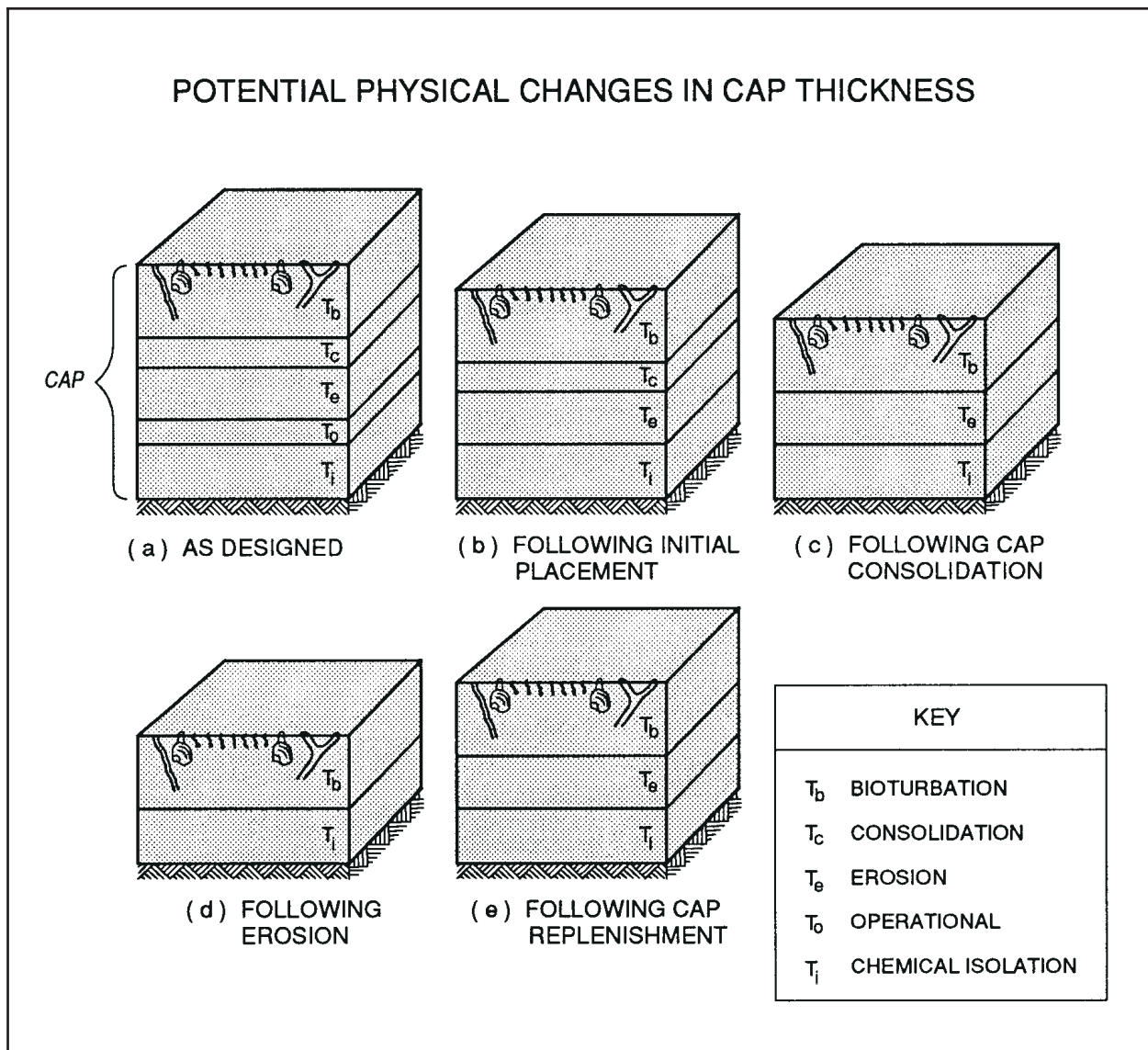

Figure 19. Schematics of cap thickness components and potential physical changes in cap thickness

The thickness for chemical isolation (if required) and/or the thickness for bioturbation must be maintained to ensure long-term integrity of the cap. The integrity of the cap from the standpoint of physical changes in cap thickness and potential for a physical reduction in cap thickness due to the effects of consolidation and erosion can be evaluated once the overall size and configuration of the capped mound or deposit and resulting water depth over the cap are determined. The design cap thickness for the various components can then be adjusted by iterative calculations if needed.

At present, the design of caps composed of clean sediments is based on a combination of laboratory tests and models of the various processes involved (contaminant flux, bioturbation, consolidation, and erosion), field experience, and monitoring data. Since the number of carefully designed, constructed, and monitored capping projects is limited, the design approach is presently based on the conservative premise that the cap thickness components are additive. No dual function performed by cap components is considered. As more data become available on the interaction of the processes affecting cap effectiveness, this additive design approach can be refined.

Before the design cap thickness can be determined, the following must be resolved: (a) the intended functions and design objectives of the cap must be defined (see Chapter 1); (b) suitable capping material must be identified (see Chapter 3); (c) a specific site must be identified and characterized (see Chapter 4); (d) equipment and placement techniques must be selected (see Chapter 5); and (e) overall geometry of the contaminated mound or deposit must be evaluated (see Chapter 6). The recommended sequence for determining the design cap thickness is as follows:

- a. Assess the bioturbation potential of indigenous benthos and determine an appropriate cap thickness component for bioturbation.
- b. Determine if the capping material is compressible, and if so, evaluate potential consolidation of the cap material after placement. If contaminated sediments or native underlying sediments are compressible, evaluate potential consolidation of those materials. If required, add a thickness component to offset consolidation of the cap.
- c. Considering the mound or deposit geometry and site conditions, conduct a screening evaluation of potential erosion. If there is potential for erosion, conduct a detailed evaluation, considering both ambient currents and episodic events such as storms. If required, add a thickness component to offset potential erosion.
- d. Evaluate operational considerations and determine restrictions or additional protective measures (e.g., institutional controls) needed to ensure cap integrity. If needed, add a thickness component to offset operational considerations.
- e. If a design function of the cap is to control contaminant flux, evaluate the potential for short-term and long-term flux of contaminants through the cap as necessary. Determine any necessary additional

cap thickness component for chemical isolation based on modeling and/or testing.

A flowchart illustrating the sequence of cap thickness evaluations and the interdependence of the components is shown in Figure 20. More detailed discussions of these design steps are given in the following paragraphs.

Bioturbation

A design objective of a dredged material cap is to physically isolate the contaminated material from benthic organisms. In the context of capping, bioturbation may be defined as the disturbance and mixing of sediments by benthic organisms. The importance of bioturbation by burrowing aquatic organisms to the mobility of contaminants cannot be overestimated. In addition to the disruption (breaching) of a thin cap that can result when organisms actively rework the surface sediments, there is the problem of direct exposure of infaunal organisms to the underlying contaminated sediment. The best available knowledge on local infauna must supplement generic assumptions concerning the bioturbation process.

Aquatic organisms that live on or in bottom sediments can greatly increase the movement of contaminants (solid and dissolved) through the direct movement of sediment particles or irrigation of pore water, increasing the surface area of sediments exposed to the water column, and as a food for epibenthic or pelagic organisms grazing on the benthos. The specific assemblage of benthic species that recolonizes the site, the bioturbation depth profile, and the abundances of dominant organisms are key factors in determining the degree to which bioturbation will influence cap performance. The depth to which organisms will bioturbate is dependent on behaviors of specific organisms and the characteristics of the substrate (i.e., grain size, compaction, organic content, pore water geochemistry, etc.). In general, the depth of recolonization by marine benthos is greater than that of freshwater benthos. Recolonization by benthic infauna at marine dredged material caps is primarily by suspension feeders as opposed to burrowing organisms (Morton 1989; Myers 1979). The intensity of bioturbation is greatest at the sediment surface and generally decreases with depth. Three zones of bioturbation are of importance (see Figure 21). A surficial layer thickness of sediment will be effectively overturned by shallow bioturbating organisms and can be assumed to be a continually and completely mixed sediment layer for purposes of cap design. This layer is generally a few centimeters in thickness. Depending on the site characteristics, a number of middepth burrowing organisms over time recolonize the site. The level of bioturbating activity for these organisms will decrease with depth as shown in Figure 21. The species and associated behaviors of organisms that occupy these surface, and middepth zones are generally well known on a regional basis. There may also be potential for colonization by deep-burrowing organisms (such as certain species of mud shrimp), which may burrow to depths of 1 m or more. However, knowledge of these organisms is very limited. These cap design criteria assume that deep bioturbators are not present in significant numbers.

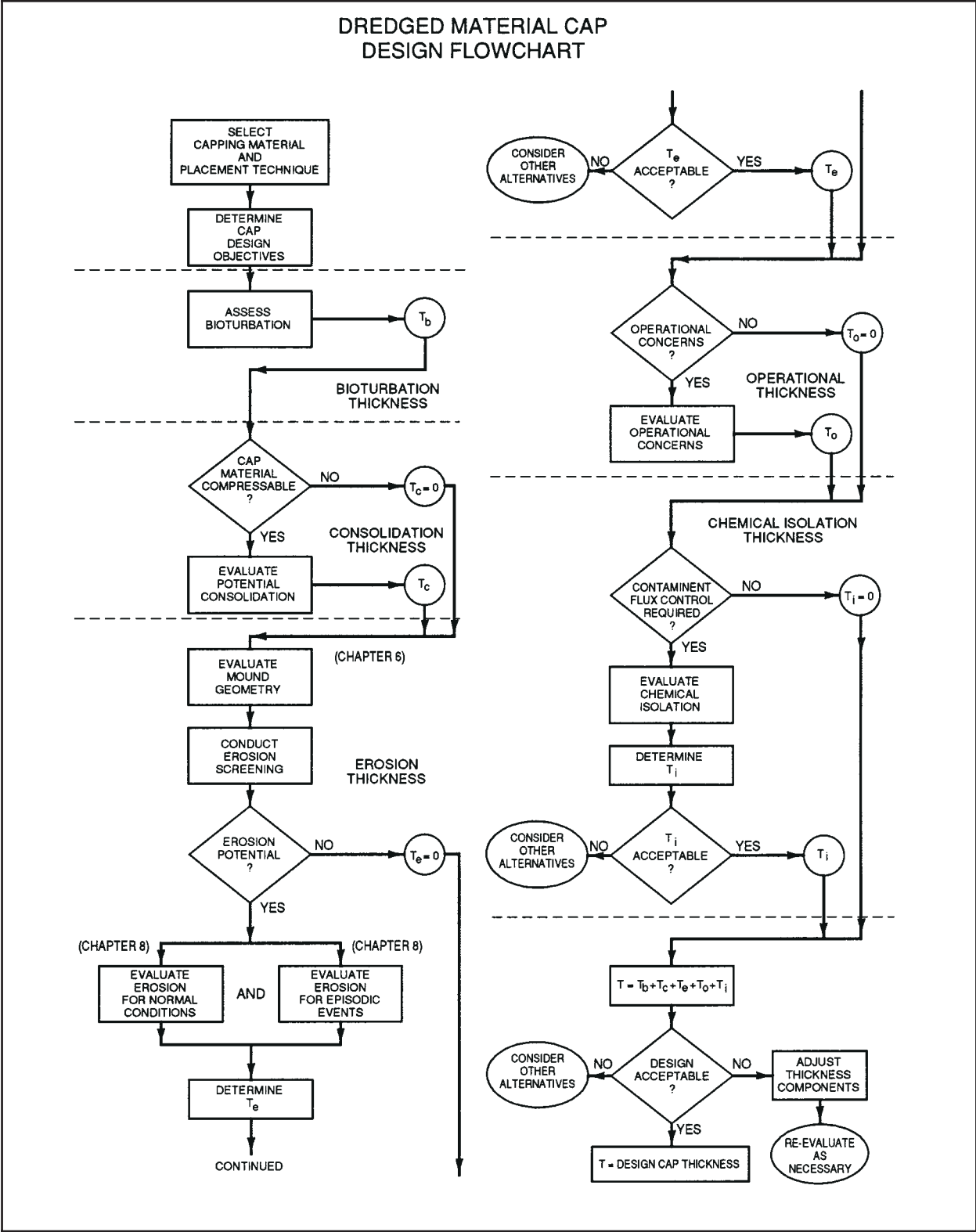

Figure 20. Flowchart illustrating sequence of evaluations for determining cap thickness

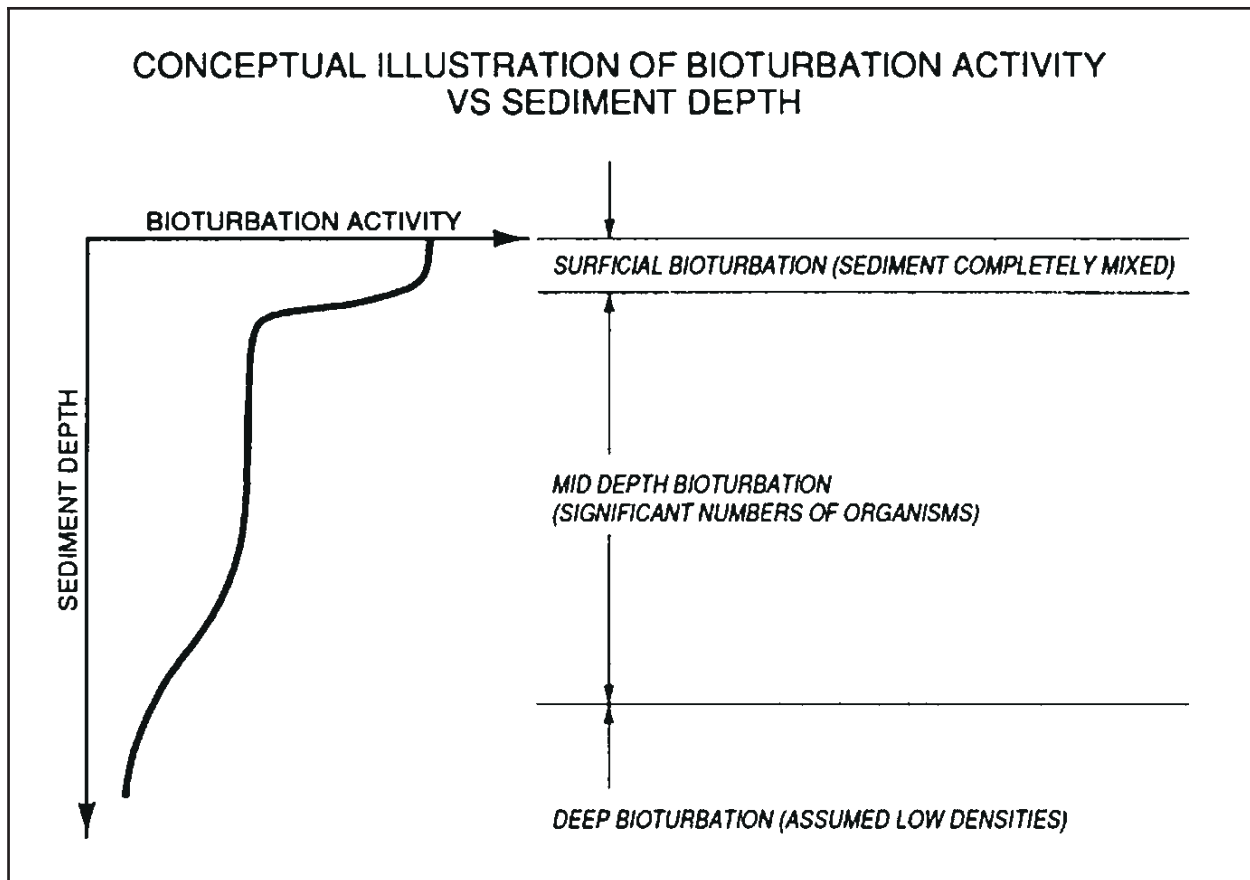

Figure 21. Conceptual illustration of bioturbation activity versus sediment depth

Cap thickness required for bioturbation, T_b , should be determined based on the known behavior and depth distribution of infaunal organisms likely to colonize the site in significant numbers. Bioturbation depths are highly variable, but have been on the order of 30 to 60 cm (1 to 2 ft) for most infaunal organisms that populate a site in great numbers. Consulting with experts on bioturbation in the region of the disposal site location is desirable. The thickness needed to prevent breaching of cap integrity through bioturbation can be determined indirectly from other information sources. For example, the benthic biota of U.S. coastal and freshwater areas have been fairly well examined, and estimates of the depth to which benthic animals burrow should be available from regional authorities.

Consolidation

Consolidation of the cap, contaminated material, or underlying native sediments may occur over a period of time following cap placement, but does not occur repeatedly. If a fine-grained cap material will be used, consolidation of the cap may require an added cap thickness component in the design such that the consolidated cap will remain at the required thickness. If any of the sediments (cap, contaminated, or native sediment) are compressible, a prediction of consolidation is important in interpreting

monitoring data to differentiate between changes in surface elevation due to consolidation as opposed to those potentially due to erosion. It is important to note that the total mound height for an LBC project or fill height for a CAD project can decrease (due to consolidation of the contaminated layer or underlying native sediment) without the need to nourish the cap.

The consolidation analysis also holds importance for any required assessment of potential long-term flux of contaminants through the cap. The magnitude of consolidation of underlying sediments will determine the amount of water potentially moving (advecting) upward into the cap. Changes in the void ratio of the cap must also be considered in determining the distance to which this water is expressed upward into the cap.

If the selected material for the cap is fine-grained material (defined as material with more than 50 percent by weight passing a #200 sieve), the change in thickness of the material due to its own self-weight or due to other cap components should be considered in the overall design of the cap thickness. An evaluation of cap consolidation should be made in this case, and an additional cap thickness component for consolidation, T_c , should be added so that the appropriate cap thickness is maintained. Such consolidation occurs over a period of time following cap placement, but does not occur more than once.

If the cap material is not a fine-grained material, no consolidation of the cap may be assumed, and no additional increase in the isolation thickness is necessary. However, consolidation of the underlying contaminated sediments may occur, and a consolidation analysis may be necessary to properly interpret monitoring data. Procedures for evaluation of consolidation are given in Chapter 8 and Appendix I.

Erosion

If there is potential for erosion, the total cap thickness should include a thickness component for erosion, T_e , which may occur primarily due to long-term continuous processes (i.e., tidal currents and normal wave activity) or episodic events such as storms. This portion of the total thickness can be lost after many years of normal levels of wave and current activity, after an abnormally severe storm season, or in a few days during extreme events. Monitoring activities should result in detecting the loss of cap followed by a management decision to place additional material to bring the cap back to its design thickness.

A screening level assessment of erosion potential should first be conducted. This assessment may be conducted as a part of the site screening process described in Chapter 4. This assessment can be based on simple analytical or empirical methods. If the screening assessment indicates little or no potential for erosion, no detailed assessment need be conducted, and no erosion cap thickness component is needed. If the screening assessment indicates a potential for erosion, a more detailed assessment should be conducted. If the contaminated material is to be hydraulically placed (as for a CAD site) or a site with higher energy potential is being

considered, a thorough analysis of the potential for resuspension and erosion must be performed, to include frequency considerations.

Based on the detailed assessment, a value of T_e should be added as the erosion cap thickness component. The criteria used to calculate the thickness to be added are equivalent to that used for the site screening discussed in Chapter 4. For projects in which no subsequent capping is anticipated for a long time period (several decades or longer) or for which materials for cap nourishment are not easily obtained, the recommended cap thickness component to be added, T_e , should be equivalent to the calculated net cap erosion over the major portion of the mound over a period of 20 years of normal current/wave energies or for a 100-year extreme event. The 20-year ambient time interval and 100-year return interval for storms are based on field experience gained to date. Twenty and one hundred years as time periods are in the range of design periods for many engineering structures. Note that calculated erosion at localized portions of the mound or feature may be somewhat greater than the value of T_e selected. The corners of a mound would normally have an overlap of capping material, and the crest of a mound would normally have a greater cap thickness; therefore, somewhat larger erosion could be tolerated over these portions of a mound.

Selection of other values of ambient time periods, return intervals, etc., for calculating erosion thickness should be based on site-specific factors (e.g., the degree of contamination, distance to other resources), the level of confidence in the calculations, and the acceptable level of risk. For projects in which subsequent capping is planned or for which materials for cap nourishment can be easily obtained, higher erosion rates may be considered. In areas where available capping materials and current and wave conditions are severe, a coarse-grained layer of material may be incorporated into the cap design to provide protection against erosive currents at the site.

Selecting a cap thickness component for erosion is a function of the acceptable level of risk. Definitive guidance is difficult because the level of risk acceptable will likely vary from project to project. Detailed guidance on erosion thickness evaluation is found in Chapter 8, along with additional discussion of the risk-related aspects associated with design cap thickness.

Operational concerns

At some locations, other considerations, termed operational, may have to be considered when determining the final cap thickness. These include ice gouging, anchoring, ability to place thin layers, unevenness of material placement, etc. If these are serious considerations, then locations that have significant potential for these types of operational considerations would be poor choices for capping projects.

For most open-water disposal sites, the sites will be located sufficiently far from shore and in sufficiently deep water that ice gouging should not be a concern. Ice gouging is obviously only a problem in areas that receive significant amounts of ice in the winter (e.g., the Great Lakes). Ice gouging occurs as ice thickness builds up, usually nearshore or adjacent to

structures, to such a thickness that the lower portion of the ice gouges and displaces the bottom sediments. The thickness of the ice buildup decreases as distance from shore increases. Also as water depth increases, ice gouging will be less of a concern. For those locations where ice gouging may be problem, e.g., in situ capping sites nearshore, local experts should be consulted as to the locations where ice gouging occurs and the depth of the sediments disturbed.

Another operational concern is anchoring. Vessel anchors have the potential to disturb bottom sediments (as do trawlers). While most any location in shallow water (say 30 m or less) is subject to potential anchoring, for most locations where open-water dredged material placement sites are located, anchoring to such a degree that cap integrity is impacted will be extremely rare. The anchors used by recreational vessels typically only penetrate the bottom 1 to 2 ft. The relative area impacted by anchors compared with the size of a cap is very small. Also, when the anchors are removed, the area disturbed by the anchor is quickly filled. This is not true for anchors from large ships, which can penetrate up to 5 to 10 ft. Thus an area where ships routinely anchor would be a very poor choice for a capping project.

Another operational concern is the ability to place a relatively thin cap layer. Until recently, open-ocean capping operations made the controlled placing of small thicknesses (less than 30 cm) difficult. For many of those projects, the minimum cap thickness for most projects has been on the order of 75 to 120 cm (2.5 to 4 ft). Recent experience from the Port Newark/Elizabeth project at the Mud Dump (Randall, Clausner, and Johnson 1994) and Puget Sound capping projects (Nelson, Vanderheiden, and Schuldt 1994; Sumeri 1995) has shown that the sprinkling techniques developed were successful and that layers about 15 to 20 cm (0.5 to 0.75 ft) thick can be placed with reasonable assurance (though at increased cost due to increased operational controls).

The placement process will likely result in some unevenness of the cap thickness. This unevenness should be considered in calculation of the volume of capping material required.

If any of the above factors are significant for the site under consideration, an additional cap thickness component for operational concerns, T_o , should be added to the design cap thickness.

Chemical isolation

If a design function of the cap is to control contaminant flux, the potential for short-term and long-term flux through the cap should be evaluated. The need for such an evaluation is dependent on the types of contaminants, the potential for contaminant impacts, site and operational conditions, and other factors. For example, if the reason for capping is to isolate a sediment that is nontoxic to benthic organisms and exhibits bioaccumulation only marginally above that for a reference sediment, the isolation provided by the bioturbation thickness component will likely provide sufficient control, and there is little reason to conduct a detailed assessment. Conversely,

if the sediment to be capped has exhibited toxicity to benthic organisms, a detailed assessment of long-term effectiveness would be advisable.

The additional cap thickness component for chemical isolation may be defined as T_i and should be determined based on modeling and/or testing as described in this section. The basis of design of a contaminant flux thickness component will be project specific. The flux rates (mass of contaminant per unit area per unit time) pore water concentrations in the cap and long-term accumulation of contaminants in cap sediments may be evaluated and used in the design. For example, flux and the resulting impact on overlying water quality may be compared with a water quality standard or criterion in much the same way as water column contaminant releases during the placement process. Compliance of the flux concentrations at the boundary of the site or edge of an established mixing zone would be appropriate. In this way, the cap thickness component for isolation required to meet the water quality standards can be determined.

Chemical flux processes

Properly placed capping material acts as a filter layer against any migration of contaminated sediment particulates. There is essentially no driving force that would cause any long-term migration of sediment particles upward into a cap layer. Most contaminants of concern also tend to remain tightly bound to sediment particles. However, the movement of contaminants by advection (movement of pore water) upward into the cap is possible. Molecular diffusion over extremely long time periods will always occur. Advection refers to the movement of pore water. Such movement could occur as an essentially continuous process if there is upward groundwater gradient acting below the capped deposit. Advection could also occur as a result of compression or consolidation of the contaminated sediment layer or other layers of underlying sediment. Movement of pore water due to consolidation would be a finite, short-term phenomena, in that the consolidation process slows as time progresses and the magnitude of consolidation is a function of the loading placed on the compressible layer. The weight of the cap will “squeeze” the sediments, and as the pore water from the sediments moves upward, it displaces pore water in the cap. The result is that contaminants can move part or all the way through the cap in a short period of time. This advective movement can cause a short-term loss, or it can reduce the breakthrough time for long-term advective/diffusive loss.

Diffusion is a molecular process in which chemical movement occurs from material with higher chemical concentration to material with lower concentration. Diffusion results in extremely slow but steady movement of contaminants. The effect of long-term diffusion on the design cap thickness is normally negligible, because long-term diffusion of contaminants through a cap is an extremely slow process and contaminants are likely to adsorb to the clean cap material particles.

Properly designed caps act as both a filter and buffer during advection and diffusion. As pore waters move up into the relatively uncontaminated cap, the cap sediments can be expected to scavenge contaminants so that

any pore water that traveled completely through the cap theoretically would carry a relatively small contaminant load to the water column. Furthermore, through-cap transport can be minimized by using a cap that has sufficient thickness to contain the entire volume of pore water that leaves the contaminated deposit during consolidation. For example, Bokuniewicz (1989) has estimated that the pore water front emanating from a consolidating 2-m-thick mud layer would only advance 24 cm into an overlying sand cap (Sumeri et al. 1991). Contaminant flux processes are very much dependent upon the nature of the cap materials. For example, a cap composed of pure sand would not be as effective in containing contaminants as a naturally occurring sand with an associated fraction of fines and organic content.

Some components for cap thickness should not be considered in evaluating long-term flux. For example, the depth of overturning due to bioturbation can be assumed a totally mixed layer and will offer no resistance to long-term flux. The component for erosion may be assumed to be absent for short periods of time (assuming the eroded layer would be replenished). Components for operational considerations, such as an added thickness to ensure uniform placement would provide long-term resistance to flux. The void ratio or density of the cap layer after consolidation should be used in the flux assessment.

Any detailed assessment of flux must be based on modeling since the processes involved are potentially very long term. Laboratory testing to more precisely determine parameters for the available models may also be conducted.

Modeling applications for cap effectiveness

A model has been developed by EPA to predict long-term movement of contaminants into or through caps due to advection and diffusion processes. This model has been developed based on accepted scientific principles and observed diffusion behavior in laboratory studies (Bosworth and Thibodeaux 1990; Thoma et al. 1993; Myers et al. 1996). The model considers both diffusive and advective fluxes, the thickness of sediment layers, physical properties of the sediments, concentrations of contaminants in the sediments, and other parameters. This model is described along with example calculations in Appendix B.

The results generated by the model include flux rates, breakthrough times, and pore water concentrations at breakthrough. Such results can be compared with applicable water quality criteria or interpreted in terms of a mass loss of contaminants as a function of time, which could be compared with similar calculations for other remediation alternatives. The model in Appendix B is applicable to the case of a single contaminated material layer and a single cap material layer, each with a homogenous distribution of material properties. The diffusion relationships used in the model have been verified against laboratory data. However, no field verification studies for the model have been conducted.

There is a need for a comprehensive and field-verified predictive tool for capping effectiveness, and additional research on this topic is planned.

The USACE has applied a refined version of an existing sediment flux model (Boyer et al. 1994) for capping evaluations, and more refinements to the model are planned to account for a comprehensive treatment of all pertinent processes. But in absence of such a tool, analytical models such as that in Appendix B should be used in calculating long-term contaminant loss for capped deposits as long as conservative assumptions are used in the calculations.

Laboratory tests for flux evaluation

Several testing approaches have been applied to define cap thicknesses and the sediment parameters necessary to model their effectiveness in chemical isolation. Laboratory tests may be used to define sediment-specific and capping-material-specific values of diffusion coefficients and partitioning coefficients. But no standardized laboratory test or procedure has yet been developed to fully account for advective and diffusive processes and their interaction.

The USACE developed a first-generation capping effectiveness test in the mid-1980s as part of the initial examination of capping as a dredged material disposal alternative. The test was developed based on the work of Brannon et al. (1985, 1986), Gunnison et al. (1987a), and Environmental Laboratory (1987). Louisiana State University has conducted laboratory tests to assess diffusion rates for specific contaminated sediments to be capped and materials proposed for caps (Wang et al. 1991). Diffusion coefficients for long-term modeling of diffusive transport of contaminants from contaminated sediment into cap material have also been measured using diffusion tubes (DiToro, Jeris, and Clarcia 1985). Environment Canada has performed tank tests on sediments to investigate the interaction of capping sand and compressible sediments, and additional tests are planned in which migration of contaminants due to consolidation-induced advective flow will be evaluated (Zeman 1993). The USACE has also developed leach tests to assess the quality of water moving through a contaminated sediment layer into groundwater in a confined disposal facility environment (Myers and Brannon 1991). This test is being applied to similarly assess the quality of water potentially moving upward into a cap due to advective forces.¹

Results of laboratory tests conducted with samples of the contaminated sediments to be capped and the proposed capping sediments should yield sediment-specific and capping-material-specific values of diffusion coefficients, partitioning coefficients, and other parameters needed to model long-term cap effectiveness. Model predictions of long-term effectiveness using the laboratory-derived parameters should be more reliable than predictions based on so-called default parameters. More detailed descriptions of test procedures for evaluation of capping effectiveness are presented in Appendix C.

¹ Personal Communication, 1995, Tommy E. Myers, U.S. Army Engineer Waterways Experiment Station, Vicksburg, MS.

Field data on long-term effectiveness

Some field studies have been conducted on long-term effectiveness of caps. Sequences of cores have been taken at capped dredged material sites in which contaminant concentrations were measured over time periods of up to 15 years (Fredette et al. 1992; Brannon and Poindexter-Rollings 1990; Sumeri et al. 1994). Core samples taken from capped sites in Long Island Sound, the New York Bight, and Puget Sound exhibit sharp concentration shifts at the cap/contaminated layer interface. For the Puget Sound sites, these results showed no change in vertical contaminant distribution in 5 years of monitoring with 18-month and 5-year vibracore samples taken in close proximity to each other. In the New York Bight and Long Island Sound sites, respectively, cores were taken from capped disposal mounds created approximately 3 and 11 years prior to sampling. Visual observations of the transition from cap to contaminated sediment closely correlated with the sharp changes in the sediment chemistry profiles. The lack of diminishing concentration gradients away from the contaminated sediments strongly suggests that there has been minimal long-term transport of contaminants up into the caps. Additional sampling for longer time intervals is planned.

These results confirm that no gross movement of contaminated sediments or contaminants occurs with a properly placed cap, that only pore water advection and molecular diffusion would act to move contaminants into a cap over the long term, that such processes move contaminants at extremely slow rates, and therefore contaminants are effectively isolated from the aquatic environment for extremely long periods (Brannon and Poindexter-Rollings 1990).

Acceptability of flux component design

If the flux evaluation indicates the design objectives are not met, additional cap thickness can be added or cap materials with differing properties (grain size and TOC) can be considered to further decrease the contaminant flux. The evaluation process could then be run in an iterative fashion if necessary to determine the chemical isolation component needed to meet the design objectives. Of course, if no reasonable combination of cap thickness and cap material properties can meet the objectives, other alternatives or control measures must be considered.

Required Design Cap Thickness and Area and Volume of Capping Material

Calculation of design cap thickness

The total design cap thickness, as initially placed, is determined as follows:

$$T_t = T_b + T_e + T_c + T_o + T_i$$

where

T_t = total cap thickness, cm

T_b = thickness for bioturbation, cm

T_e = thickness for erosion, cm

T_c = thickness for consolidation, cm

T_o = thickness for operational considerations, cm

T_i = thickness for physical/chemical isolation, cm

Areal coverage of the full cap versus apron cap

For a capping operation to be successful, the required cap thickness must be placed over the deposit of contaminated material. Typically, the edge of the contaminated mound will be detected with an SPC, which can reliably detect contaminated layers of thickness of 1-2 cm. Within this context, the contaminated material deposit is considered that which can be detected. However, it is not possible or necessary to cap every particle of contaminated material with the full design cap thickness.

For LBC projects, capping operations should be aimed at placing the full design cap thickness over the central portion of the mound and inner and outer flanks of the mound as defined in Chapter 6. As contaminated material is placed to form the mound, material settles to the bottom as the apron in ever-decreasing thicknesses with increasing distance from the point of discharge. The capping material is similarly dispersed, especially if the grain size and placement methods are similar. Therefore, operations aimed at placing the design thickness over the geometry of the mound that can be defined by bathymetric surveys will result in somewhat thinner layers of capping material being placed over the apron, as defined in Chapter 6.

Monitoring techniques are discussed in Chapter 9. Differential bathymetric surveys can determine the extent of a deposit down to a thickness of approximately 15 to 30 cm, while an SPC can detect sediment thicknesses from 2 to 20 cm. A combination of these approaches can be used to define the areal extent of the contaminated material mound and subsequently the required areal extent of the full capping thickness.

For CAD projects in which the contaminated material is placed as a layer of uniform thickness within the contained area, the full design cap thickness should be placed over the entire surface area.

Volume calculations

Once the design cap thickness and required areal extent of the cap are determined, the required volume of capping material can be estimated. There is no minimum acceptable ratio of capping to contaminated sediment

volumes for capping. The requirement is to cap the deposit of contaminated material with the required thickness of capping material. The areal extent of the contaminated material deposit and required cap thickness are the key factors in calculating the volume of cap material. For example, if a large volume of contaminated material were placed in a subaqueous depression or pit (a CAD project), the deposit could be satisfactorily capped with a relatively small volume of capping material. Additional considerations on cap areas and volumes are provided in Appendix H.

Acceptability of design

Once the total cap thickness is determined, the calculations used to arrive at each of the components should be reexamined and the acceptability of the design evaluated. Some recalculations using an iterative process may be necessary because total cap thickness influences the water depth above the cap, which influences erosion potential, and total cap thickness as placed influences the magnitude of consolidation of the cap. However, in most cases, the calculations will not be overly sensitive to the overall cap thickness, and recalculation of specific thickness components should not be required.

The overall design of the cap should also be examined with respect to acceptability from the operational, logistical, and economic perspectives. If the total cap thickness is too large for effective placement, or the needed volume of cap material is not available, or the anticipated cost of capping too great, alternate sites or other disposal alternatives should be considered.

Considerations for Intermediate Caps

Some capping projects could be designed in the context of anticipated multiuse or multiuser applications. In such a case, one site (e.g., a subaqueous borrow pit) could be selected for placement of contaminated sediments from several projects. If several placements of contaminated sediments are to be placed with such frequency that the site could not effectively recolonize, there would be no pathway for bioaccumulation or benthic toxicity. Also, if the site is located in a sheltered area, or the energy from low-frequency events would not cause significant erosion, no placement of cap material or placement of an intermediate cap with a lesser thickness. That is, one that has a shorter return period level of erosion protection or less capabilities for chemical or biological isolation than the full design cap could be considered. Determining an appropriate thickness for an intermediate cap would require an evaluation of the same processes as described above, but the design parameters (especially those for long-term flux, return periods for storms, etc.) should be selected to represent the time periods anticipated between dredged material and intermediate cap placement and final cap placement.

8 Long-Term Cap Stability

Considerations in Long-Term Stability

When contaminated material is isolated from the environment through a dredged material capping operation, it is essential that not only the precision and thoroughness of initial cap placement be considered but also the long-term integrity, or stability, of the capped deposit be evaluated on a regular basis. A critical element in successful performance of a cap is preservation of an adequate thickness of this clean material to control flux of contaminants and isolate the contaminated sediments from benthic organisms. In evaluating long-term cap stability, factors that must be addressed include the following:

- a.* Possible consolidation (of capping material, contaminated sediment, and foundation material) for effect on long-term site capacity, differentiation from erosion, and quantification of contaminated pore water volume expelled.
- b.* Potential for erosion (considering the wave and current conditions at the disposal site and dredged material particle size and cohesion).

If erosion or consolidation causes the cap to be too thin to effectively isolate the contaminated material from the surrounding environment, then remedial actions will be required to reestablish cap integrity. This chapter presents detailed procedures to evaluate long-term physical stability of subaqueous dredged material caps, considering consolidation and erosion processes. These processes are discussed in the following paragraphs, along with recommended techniques and computer models available for analysis.

A critical step in cap design is to use the information from Chapter 7 in determining a design cap thickness (or a trial thickness for detailed evaluations such as described in this chapter). Selecting a design cap thickness is a function of an acceptable level of risk. Assessment of consolidation is mathematically straightforward, while the very stochastic nature of erosion makes it much more complicated to predict. Definitive guidance on cap stability is difficult because the level of acceptable risk will likely vary from location to location. Further discussion of risk-related cap design topics are found at the end of this chapter.

Evaluation of Consolidation

For LBC projects, dredged material typically forms a mound of material on the bottom of the water body. If a clean sediment is placed to isolate the contaminated material from the surrounding environment, the capping material increases the size of the existing mound and also places a surcharge load on the underlying dredged material and further increases the surcharge load on the foundation soil. Because the contaminated sediments are usually fine grained and have a relatively high moisture content, they are often susceptible to large amounts of consolidation. For CAD projects, the materials are layered but are subject to the same consolidation processes.

Assessing consolidation potential of capped dredged material mounds or deposits requires consideration of the consolidation potential of three elements: the cap, the contaminated dredged material, and the native or substrate sediments (foundation soils). The contaminated dredged material (which is usually fine-grained, cohesive material) likely will undergo consolidation resulting both from its own self-weight and from the surcharge load of the capping material. If the capping material is fine grained (e.g., silt or clay), it will also be susceptible to consolidation. Coarse-grained capping material (e.g., sand or gravel) would not normally be expected to consolidate. The final element to be considered is consolidation potential of the foundation soils. If these soils are fine-grained materials susceptible to consolidation, the loading applied by the contaminated and capping material will probably be sufficient to cause consolidation.

Quantifying consolidation is necessary for three reasons. First, changes in elevation due to consolidation must be delineated from those due to erosion. Decreases in the elevation of the mound or deposit surface caused by erosion of the cap may require remedial actions to replenish and restore the cap to its required thickness. If consolidation of constituent materials accounts for the change in elevation, then no cap replenishment is necessary, particularly if cap thickness design accounted for, a priori, potential cap consolidation. Thus it is imperative that consolidation be distinguished from erosion. Second, consolidation should be considered when determining long-term site capacity. As a mound consolidates and decreases in elevation, additional volume becomes available between the mound surface and the plane of maximum acceptable mound elevation; this volume can be used for storage of additional dredged material. The increases in the storage capacity of subaqueous disposal sites due to consolidation are especially important when these sites will be used to store large quantities of material from several dredging operations occurring over a number of years. Thus the ultimate holding capacity of repeated-use sites will be significantly increased if consolidation is considered. Third, a consolidation analysis will provide data needed to evaluate the potential movement of pore water from the contaminated sediment upward into the cap, and this is necessary in evaluating the potential for long-term flux of contaminants.

Many soft fine-grained materials may undergo on the order of 50-percent vertical strain during the consolidation process. Therefore, the objective of consolidation analysis is to determine the amount and rate of consolidation that the mound and/or foundation soils will undergo as a result of self-weight consolidation and/or surcharge loading. One-dimensional (1-D) consolidation analysis is normally used in geotechnical engineering. In a 1-D analysis, pore water is expelled vertically (upward and/or downward) from soil layers; no horizontal flow or strain is allowed. Few 2-D or 3-D analyses are ever performed, and these are usually conducted on research projects. Because of the configuration of subaqueous sediment mounds (relatively flat slopes and thin lifts), a 1-D analysis of mound consolidation should provide adequate results for either design or analysis of these mounds. However, in the future, development and use of 2-D or 3-D consolidation models would permit more accurate prediction of the actual direction and magnitude of flows and movements.

Fine-grained dredged sediments, especially those placed by pipeline or hopper dredge, are initially soft and have a high water content, with an associated high compressibility. Potential changes in height (strains) due to consolidation are large; therefore, a finite strain approach that accounts for the large strains should be used to evaluate consolidation (Rollings 1994; Poindexter 1989).

Consolidation testing

Laboratory consolidation test data are necessary for an evaluation of consolidation; however, standard procedures for consolidation tests (USACE 1970) may not be applicable for testing of soft sediment samples. A modified version of the standard oedometer consolidation test (USACE 1987) and a self-weight consolidation test (Cargill 1985) have been developed that provide data for the wide range of void ratios that may be encountered in the context of dredged material placement operations. Additional details on consolidation testing are given in Appendix I.

Consolidation models

The complexity and number of calculations required to predict consolidation of deposits using large strain consolidation theory require use of a computerized solution technique. The theory of finite strain consolidation (Gibson, England, and Hussey 1967) has been incorporated into several generations of computer models for analyzing consolidation of capped sediment mounds (Cargill 1985; Poindexter-Rollings 1990; Stark, in preparation). To run any of these models, consolidation test data from self-weight consolidation tests and/or standard oedometer tests (USACE 1970; USACE 1987) are required (See Appendix I).

Initial work on consolidation of dredged material was done with the computer model PCDDF (Primary Consolidation and Desiccation of Dredged Fill) (Cargill 1985), which was later modified and released as PCDDF89 (Stark 1991); these programs were developed specifically for analysis of confined upland disposal sites. Subsequent work on

consolidation of subaqueous capped mounds was done with MOUND (Poindexter 1989; Poindexter-Rollings 1990). This program incorporated capabilities for analyzing deposits that were subjected to surcharge (cap) loads and included an empirical relationship between shear strength and void ratio, plasticity index, and activity of the sediment particles. Most recently, PCDDF89 has been updated to include secondary compression; this version is known as PSDDF (Primary Consolidation, Secondary Compression, and Desiccation of Dredged Fill) and is likely the most user-friendly version (Stark, in preparation). Each of these computer programs is based on the same 1-D theory of consolidation and is capable of predicting the consolidation of multiple compressible layers. Computational details and processing speeds vary among the programs, but similar consolidation estimates should be obtained from each.

In evaluating consolidation, both the rate and the magnitude of consolidation should be determined separately for the contaminated sediment, the capping material, and the foundation layers, as appropriate. Then for any given time of interest, the individual settlement values for the foundation, contaminated sediment, and capping sediment should be summed to provide an estimate of the total amount of settlement to be expected at that particular time. This information can be used in conjunction with field-monitoring data in the ongoing assessment of cap integrity. The change in thickness of the capping layer is of primary concern from an environmental containment perspective. However, the total amount of consolidation settlement, or decrease in elevation, of the cap surface over time is necessary to delineate between mound height changes caused by erosion and those accounted for by consolidation of constituent materials.

Because consolidation settlement of capped mounds can be mistaken for erosion of the cap, estimates of consolidation of capped mounds should be made when mound geometry is established and should be routinely compared with field-monitoring data thereafter. Estimating consolidation of capped mounds requires collection of appropriate samples, conducting necessary geotechnical testing (as described in Chapter 3), and conducting a consolidation analysis for each compressible material (foundation, contaminated sediment, and/or capping material).

The MOUND model and another consolidation model, CONSOL (Gibson, Schiffman, and Cargill 1981; Wong and Duncan 1984), were used to predict consolidation of three capped dredged material mounds in Long Island Sound (Silva et al. 1994). Bathymetry of these sites showed reductions in mound elevations of up to 3.5 m over time periods of 10 to 13 years after cap placement. Comparisons between consolidation and bathymetry estimates were made to show that the reductions in mound elevation could be attributed to consolidation rather than cap erosion. These results compare favorably with earlier analyses of the same capped mounds in which the predictions were also validated by field measurements (Poindexter 1989). Results showed the two models used in the recent study were reasonably accurate in predicting consolidation, that consolidation of the base (native) sediments can constitute a majority of the observed consolidation, and that the caps had not experienced erosion losses. The work also pointed out the need to obtain more accurate geotechnical information on the void ratios and initial effective stress of the contaminated materials.

Typical consolidation results

As in all consolidation analyses in geotechnical engineering, the profile of the deposit (including thickness and extent of each material) must be determined. An idealized mound geometry for an LBC project is shown in Figure 22. The consolidation of the mound is then predicted using an appropriate finite strain consolidation model, and the results should then be plotted.

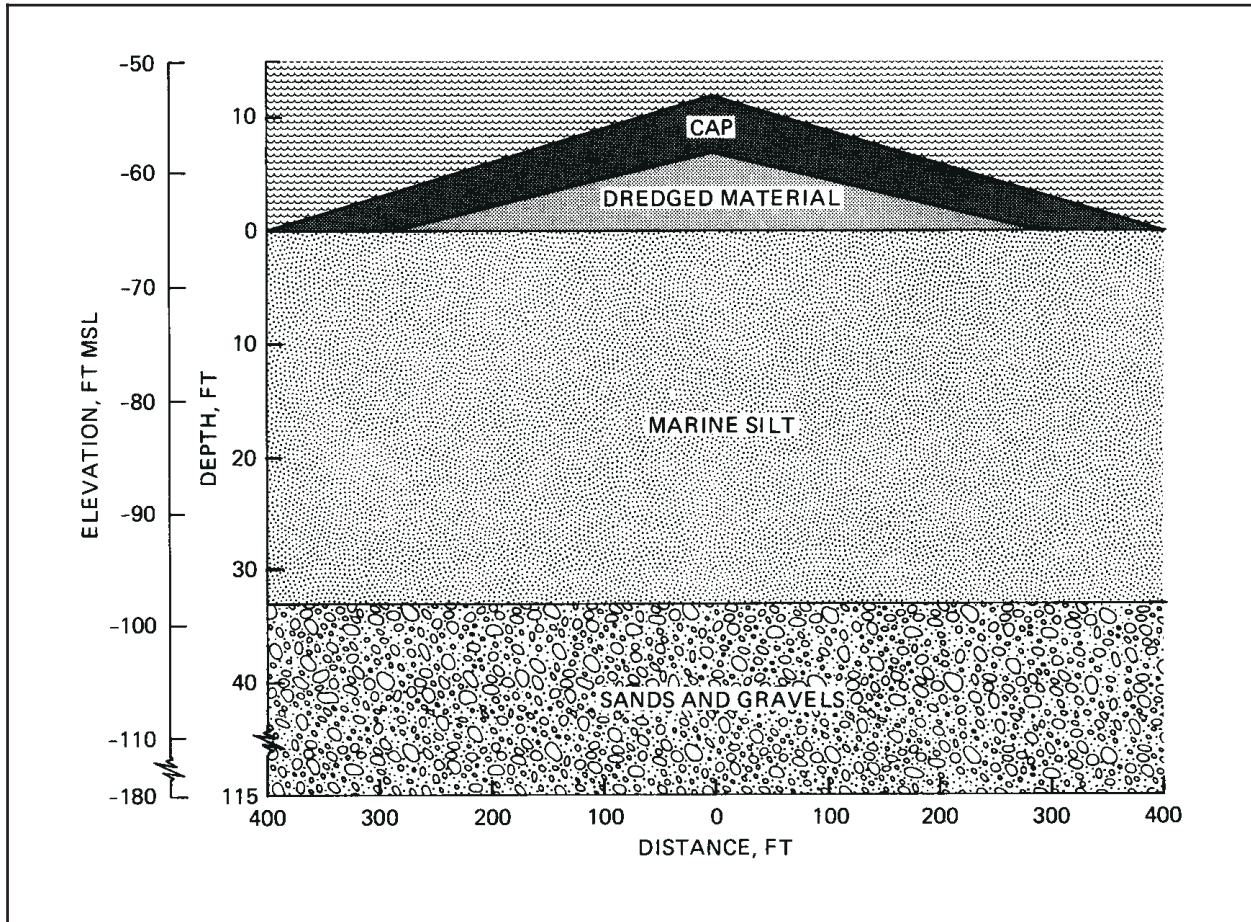

Figure 22. Idealized soil profile of mound and foundation soils

Two types of plots are often used to show the amount of consolidation that is expected to occur in a dredged material mound. The ultimate change in elevation of the mound surface is often plotted to show the change in configuration that can be expected following consolidation. Figure 23 shows the original and final mound height when consolidation only (i.e., no erosion) is considered. Secondly, a plot is usually constructed of settlement over time at a particular point or points in the mound. This plot can show the individual quantities of consolidation settlement predicted for the capping material, the contaminated dredged material, and the foundation soil; it will normally also show the total settlement expected. This type of plot is very useful for comparing predicted settlement (or surface elevation) with field-monitoring data. Figure 24 shows

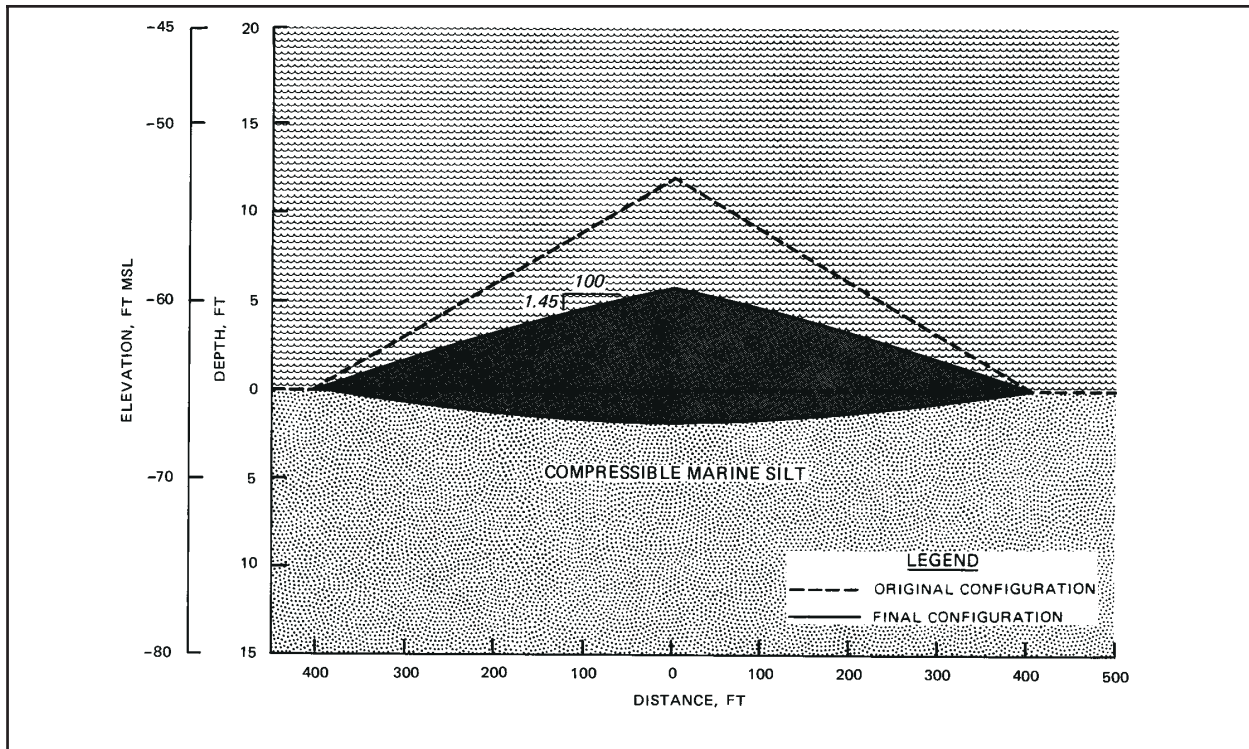

Figure 23. Predicted final mound configuration at completion of consolidation

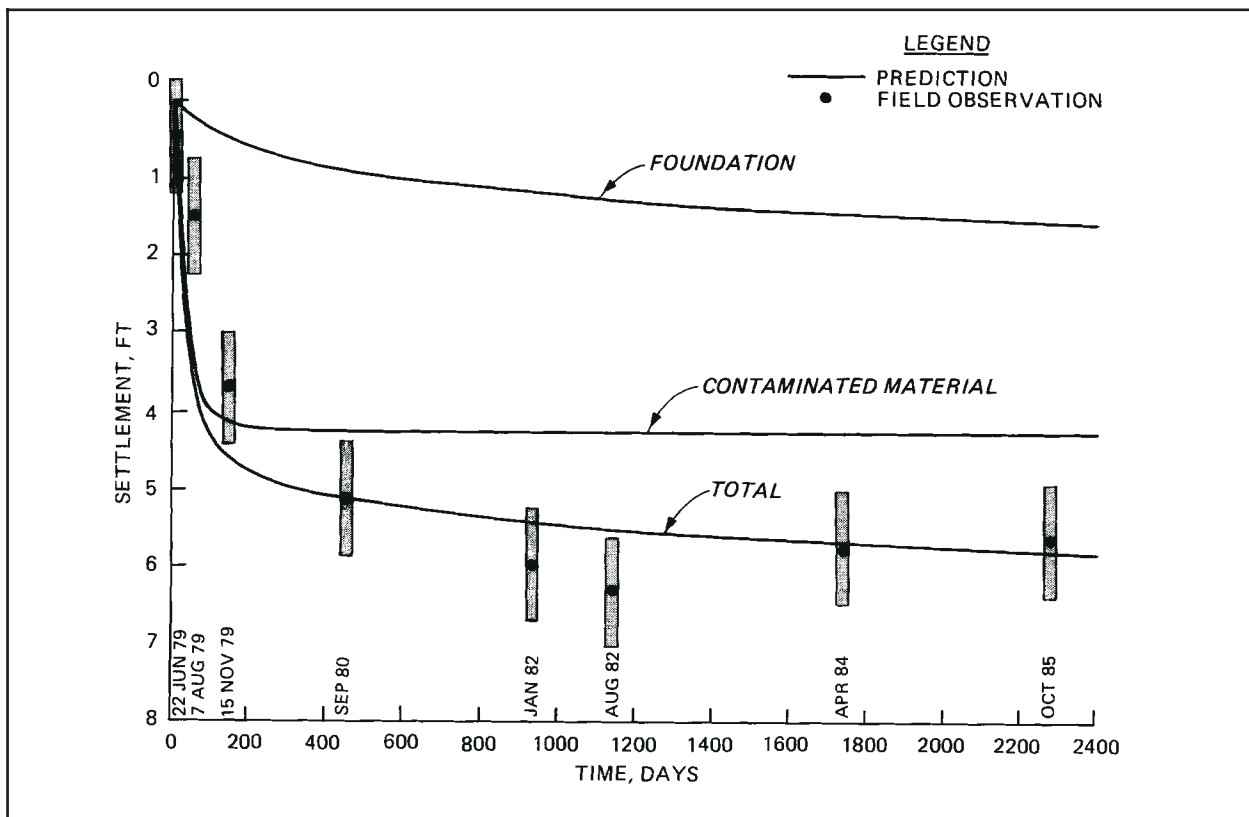

Figure 24. Time rate of consolidation at center of mound

the predicted time rate of consolidation as compared with actual field data.

Evaluation of Erosion Potential

If practical, capping should normally be conducted predominantly at sites that are classified as nondispersive, i.e., sites with relatively little potential for erosion. However, existing sites with more frequent potential for erosion can be used for capping projects after completing studies of the frequency of erosion of a specific capping material (considering grain size, mound geometry and sediment cohesion) for expected wave and current conditions (to include storms) over time predicted in the area. The results from such a study will provide data that can be used to predict the expected cumulative amount of erosion over time along with confidence intervals on the answers. The estimated erosion amounts can then be used to define the design cap thickness component for erosion protection required for a given length of time (say 20 to 100 years). Cap thickness should be monitored periodically as well as after large storm events to verify cap stability and measure cap erosion rates. In addition, minimum thicknesses for contaminant isolation should be predetermined. If monitoring indicates that cap thickness has been reduced below the minimum values, contingency plans should be enacted to place additional capping sediments.

The deposit of contaminated dredged material must also be stable against excessive erosion and resuspension of sediment before placement of the cap. The potential for resuspension and erosion depends on bottom-current velocity, potential for wave-induced currents, sediment particle size, and sediment cohesion. Site selection criteria as described above would normally result in a site with low bottom-current velocity and little potential for erosion during the window for placement of the contaminated sediments and cap. However, if the contaminated sediment is hydraulically dredged, erosion potential is greatly increased due to the high water content of the slurry (eventually this water content decreases, thus reducing erosion potential). In this case, a thorough analysis of the potential for resuspension and erosion should be performed to estimate the short- and long-term effects on resuspension potential. Conventional methods for analysis of sediment transport are available to evaluate erosion potential (Teeter 1988; Dortch et al. 1990; Resio and Hands 1994; Scheffner 1991a,b). The first level of investigation of cap stability against erosion involves examination of the normal wave and current regime to determine if these cause measurable amounts of erosion. However, sites where day-to-day waves and currents cause measurable amounts of erosion would be poor sites for capping projects.

Estimating critical conditions for initiation of motion in wave or current environment

For most sediment bed compositions, a critical stress value exists below which no or negligible sediment movement occurs. Stress is the force

per unit area applied to the sediment bed surface by water movement. This critical value is usually called the critical shear stress for initiation of motion. Estimating the shear stress for given conditions is not a simple calculation and may depend on a multitude of variables. However, under many conditions, given a few basic parameters, an estimate can be made for the shear stress that can tell the engineer if sediment deposits are in the range where sediment movement may occur (i.e., above the critical value). This can be done for a wave environment or a current environment. This section contains graphs that, if a few basic parameters are known (such as median grain size, wave height, wave period, water depth, and current), a reasonable estimate of stress can be developed. The calculations for combined current/wave environments cannot be plotted easily. Under these conditions, the relationships become much more complex, and a detailed study is required to determine the bottom stresses and ultimate dispersive/nondispersive classification of the site.

The dashed lines in Figure 25 plot the critical value of the vertically averaged current velocity (u_{cr}) versus the median grain size (d_{50}) for various water depths. The expression for u_{cr} , as described by van Rijn (1993), is defined as a function of the water depth h and grain size distribution. This simplified equation, based on Shields curve for initiation of motion and assuming effective bed roughness can be estimated as $3d_{90}$ (where d_{90} is the 90th percentile grain size, i.e., 90 percent of the material is finer) and $d_{90} = 2d_{50}$ can be expressed as:

$$\bar{u}_{cr} = 0.19(d_{50})^{0.1} \log\left(\frac{12h}{3d_{90}}\right) \quad \text{for } 0.0001 \leq d_{50} \leq 0.0005 \text{ m}$$

$$\bar{u}_{cr} = 8.50(d_{50})^{0.6} \log\left(\frac{12h}{3d_{90}}\right) \quad \text{for } 0.0005 \leq d_{50} \leq 0.002 \text{ m}$$

As stated previously, the above equations calculate the approximate critical vertically averaged velocity value for the initiation of sediment movement. At these values, the particles will start to roll or move across the bottom in fairly regular jumps (saltation). There are also higher stress levels at which the particles will leave the turbulent bottom boundary layer and be brought into suspension. These values are called the critical velocities for initiation of suspension and are indicated by the solid lines in Figure 25. These values can be approximated, using the same assumptions as for u_{cr} , by:

$$\bar{u}_{cr,s} = 5.75[(s-1)gd_{50}]^{0.5} (\Theta_{cr,s})^{0.5} \log\left(\frac{12h}{3d_{90}}\right)$$

where s is the sediment specific gravity; g is acceleration of gravity; and $\Theta_{cr,s}$, the critical Shields parameter for suspension, is defined by:

$$\Theta_{cr,s} = \frac{16}{D^{*2}} \frac{w_s^2}{(s-1)gd_{50}} \quad \text{for } 1 < D^* \leq 10$$

$$\Theta_{cr,s} = 0.16 \frac{w_s^2}{(s-1)gd_{50}} \quad \text{for } D^* > 10$$

w_s is the sediment settling speed (which can be estimated for a given grain size from charts or by Stokes law) and the dimensionless particle parameter, D^* , is defined by:

$$D^* = \left[\frac{(s-1)g}{\nu^2} \right]^{1/3} d_{50}$$

The value for the kinematic viscosity, ν , is approximately $1 \times 10^{-6} \text{ m}^2/\text{s}$.

For determining the stability of a specific site, Figure 25 can be used to indicate potential for site erosion when a distribution of the vertically averaged velocities, bed grain-size distribution, and water depth are known. If the velocities are frequently above u_{cr} , then there is a potential for some site erosion. There is a strong likelihood for severe erosion if the velocities frequently exceed $u_{cr,s}$. It should be emphasized that if there is any question concerning site stability, i.e., Figure 25 does not clearly indicate that erosion will not occur, more detailed data collection and modeling efforts should be undertaken to determine erosion potential.

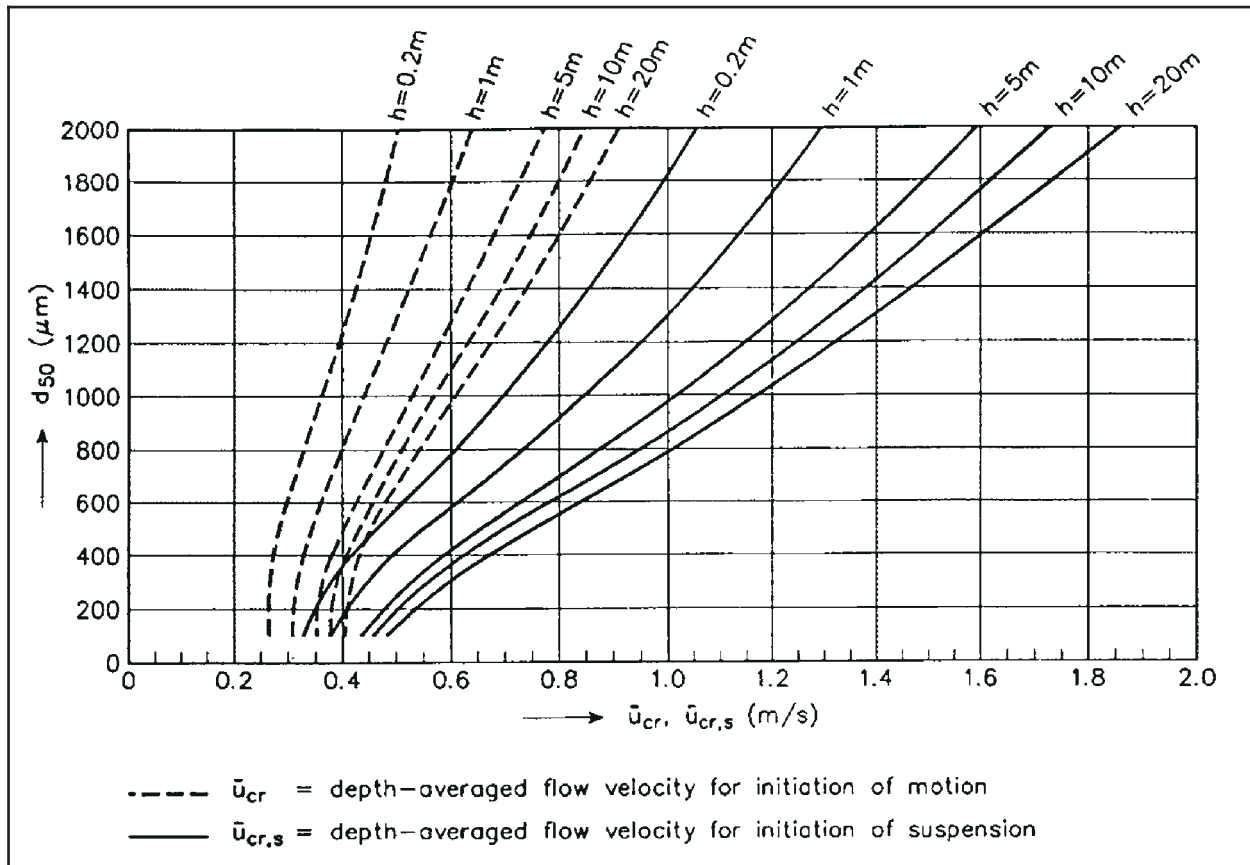

Figure 25. Critical vertically averaged velocities for a plane bed (from van Rijn 1993)

Under wave-dominated conditions, the orbital velocities produced by waves will be the primary force agitating the sediment bed surface and producing erosion. Because of the unsteady nature of the orbital velocities (compared with the relatively steady currents), a peak orbital velocity of similar magnitude to a current velocity will not result in similar shear stresses at the sediment-water interface. The current boundary layer is fully developed and much thicker than that for continually changing orbital velocities. Therefore, bottom shear stresses created by a similar magnitude orbital velocity will be much greater than that for current velocity and Figure 25 will not apply. Due to the complexity of wave/bottom stress complexities, there is no general agreement amongst researchers on a proper method for estimating bottom effects. However, it is possible, without a detailed analysis, to develop a first order magnitude estimate that will assist the engineer in determining site stability for a plane bed. The method described here was developed by van Rijn (1989), and a brief overview is presented in van Rijn (1993). Figure 26 plots wave period, T , versus the critical peak orbital velocity at the bed, $u_{\delta,cr}$. The solid lines are the experimentally determined values of the critical value for the initiation of motion. The average inaccuracy of the curves is 25 percent. The value of U_{δ} for conditions at a specific site can be evaluated by:

$$U_{\delta} = \frac{\pi H}{T \sinh(kh)}$$

where

H = significant wave height

T = wave period

k = wave number

The wave number k can be determined from the wave length L by the equation $k = 2\pi/L$. The wave length in turn is determined by iteration of the equation:

$$L = \frac{gT^2}{2\pi} \tanh(2\pi h/L)$$

The user can then compare the value of U_{δ} to the critical value, $U_{\delta,cr}$, for a known median grain size and wave period using Figure 26. If the values of U_{δ} is greater than $U_{\delta,cr}$, then the potential for erosion is significant. Even if the value is only slightly less than critical, given the margin of error in the estimates presented in Figure 26, the engineer should seek further detailed analysis to determine site stability. However, if the value is significantly less than critical, the site can be assumed stable.

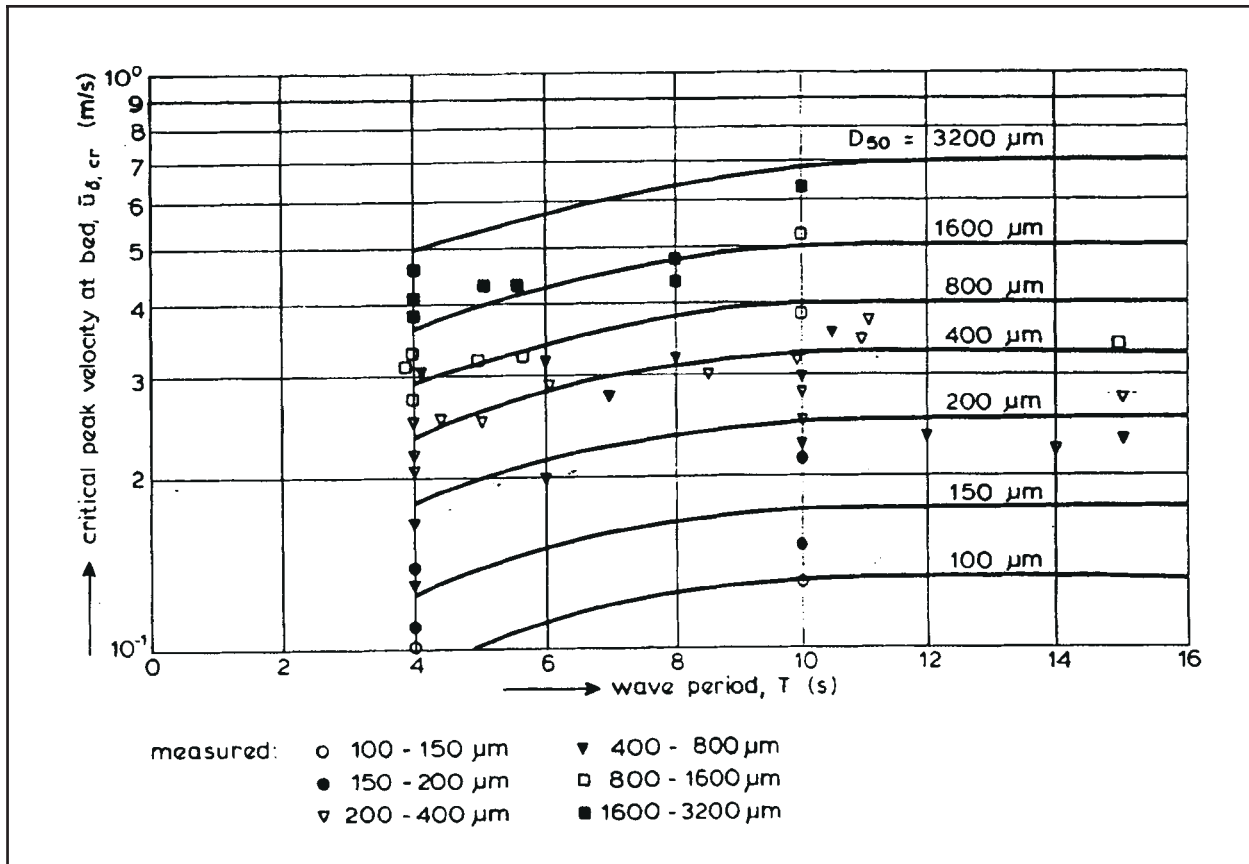

Figure 26. Initiation of motion for waves over a plane bed based on critical velocity (from van Rijn 1993)

Example 1, Current-dominated environment: If the region of interest is in 10 m of water, the median grain size (d_{50}) is 500 μm , then the critical velocity for initiation of motion from Figure 25 is approximately 44 cm/s, and the critical velocity for initiation of suspension is 70 cm/s (these values can also be calculated from the equations in this section). If the vertically averaged velocity for a particular storm frequently exceeds 50 cm/s with peak velocities around 65 cm/s, then it can be assumed that the sediment bed will experience some erosion during the storm.

Example 2, Wave-dominated environment: The water depth is 5 m, wave period is 7 s, wave height is 0.5 m, and d_{50} is 200 μm .

For these conditions, it is determined that $L = 46 \text{ m}$ and $k = 0.14 \text{ m}^{-1}$. Using the supplied equation, $U_{\delta} = 0.30 \text{ m}$. From Figure 26, for a d_{50} of 200 μm and wave period of 7 s, $U_{\delta, cr}$ is approximately 0.24 m/s. Therefore, the bottom shear stresses generated by these conditions, represented by $U_{\delta} = 0.30 \text{ m}$, are greater than the critical value of 0.24 m/s, and erosion will occur under these conditions.

Predicting erosion magnitude and rate

Predicting erosion thicknesses, which consists of computing a resuspension rate (the volume or mass of material put into movement by the currents per unit of time and area), net transportation rate (how fast is the sediment mass or volume moved horizontally), net transportation gradient (is more sediment moving out of a given area than moving in), and the duration of the erosion, is a difficult task that requires a sophisticated numerical model to obtain reasonable results at an open-water site.

Erosion of fine-grained cohesive sediments is even more complicated than for cohesionless particles because of interparticle forces (i.e., cohesion), the fact that cohesive forces can vary with depth (i.e., become more erosion resistant), cohesive forces are time dependant (density and cohesion increase with time), and other factors (e.g., salinity). In contrast, cohesionless sediments are considerably simpler because the erosion resistance does not change with depth, time, or sediment chemistry. Thus, modeling erosion of cohesive sediments is much more difficult than for cohesionless sediments.

A model was developed as a part of the USACE Dredging Research Program (DRP) to evaluate the long-term fate of a mound, i.e., mound stability over periods ranging from months to years (Scheffner 1991a,b). This model is called the Long-Term FATE of dredge material (LTFATE) model (Scheffner et al. 1995). In LTFATE, hydrodynamic conditions at a site are considered using simulated databases of wave and current time series or actual wave and current data as driving forces. These boundary conditions are used to drive coupled hydrodynamic, sediment transport, and bathymetry change models that predict erosion of dredged material mounds (of specific dimensions, grain size, and water depth) over time. LTFATE uses empirically derived methods to estimate either noncohesive (Ackers and White 1973) or cohesive (Lavelle, Mofjeld, and Baker 1984) sediment resuspension, transport, and deposition. Results from this model indicate whether a given site is predominantly dispersive or nondispersive and predict potential erosion and migration of a mound for the given current and wave conditions, mound geometry, and sediment characteristics. Typical results from the model are shown in Figure 27. Appendix F describes the model in more detail by providing background, major assumptions and limitations, input requirements, and sample output.

The LTFATE model has recently been applied in hindcasting the stability of a capped mound located in the Mud Dump site, a designated ocean-disposal site in the New York Bight, during a severe storm that occurred in December 1992 (Richardson et al. 1993). In this application, wind and wave data from a directional wave buoy operated by the National Data Buoy Center of the National Weather Service, data on current and tidal fluctuation from a verified Bightwide numerical hydrodynamic model, and data on historical storm and surge effects in the area were used to develop bottom currents for a range of storm-induced conditions at the proposed capped mound location. The model was used to predict the magnitude of resulting cap material erosion. Long-term stability of the mound was also evaluated using empirical criteria from nearshore berms to determine the potential for significant movement of the overall capped feature using criteria from other monitored sites. This study provides a model for

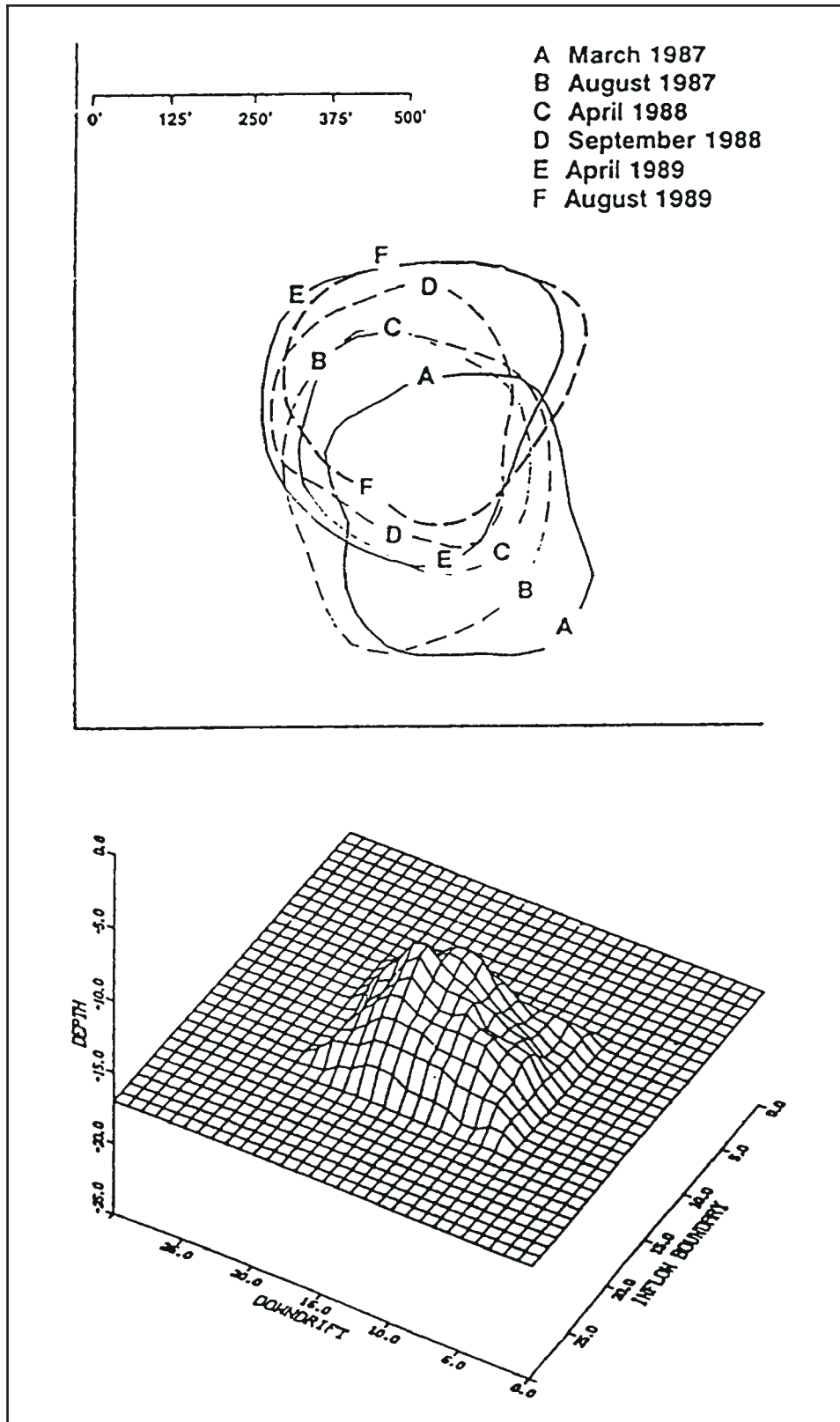

Figure 27. Typical LTFATE model results showing long-term changes to mound geometry

comprehensive evaluation of the potential mound stability from a single storm. A more comprehensive approach, however, is to evaluate the long-term physical stability by computing the frequency of occurrence of erosion over much longer periods. This procedure is described in the following section.

Frequency of erosion studies

While it is desirable to site capping projects in low-energy areas with little or no potential for erosion, these sites are not always available. At higher energy sites, the potential for erosion has to be estimated and taken into account when designing the cap. Stated simply, an additional layer is added to the overall cap thickness to account for expected erosion over a finite time period. Knowledge of the frequency of occurrence of vertical erosion (i.e., how often a given amount of vertical erosion will occur) is a critical component of a probabilistic cap design. Too thin an erosion layer may compromise the cap, potentially allowing the contaminants to be dispersed over the site and surrounding area. Conversely, too thick cap will have an unnecessarily high cost and also reduce the capacity of the site to contain additional dredged material. This section describes a rational method to determine the erosion layer thickness for sites where erosion is expected to be a problem. A detailed explanation of the frequency of erosion procedure and background information is provided in Appendix G.

The amount of expected erosion will be a function of the depth of the capped mound, mound geometry, the material used for the cap, and environmental forcing functions at the site, waves and currents, and their duration. The designer/project manager can influence the depth of the capped mound and the type of cap material. Therefore, most frequency of erosion studies of capped mounds require an investigation of a range of mound elevations (and thus water depths) and several different types of cap material, e.g., sand of various grain sizes and typical fine-grained (silt and clay) maintenance material.

Among existing procedures for computing frequency of erosion due to tropical and extratropical storms (e.g., worst case “design storms” or the joint probability method(JPM)), the empirical simulation technique (EST) is the best. EST is a statistical procedure for simulating nondeterministic multiparameter systems such as tropical and extratropical storms. The EST, which is an extension of the “bootstrap” statistical procedure (Efron 1982; Efron 1990), overcomes the JPM limitations by automatically incorporating the joint probability of the historical record. The bootstrap method on which EST is based incorporates resampling with replacement, interpolation based on a random walk nearest neighbor techniques with subsequent smoothing. More detailed descriptions of EST can be found in Scheffner, Borgman, and Mark (1993) and Borgman et al. (1992).

In EST, the various geometric and intensity parameters from storms are used to create a large artificial population (several centuries) of future storm activity (Borgman et al. 1992). The only assumption required for EST is that future storms will be statistically similar to past storms. Thus, the future storms generated during EST simulations resemble the past

storms but possess sufficient variability to fill in the gaps in the historical data.

To perform the EST, historical storms impacting a site are broken down into the parameters that impact the engineering aspect of interest: storm track, maximum winds, radius to maximum, pressure deficit, etc. These variables are termed input vectors. The storm response of interest, in this case vertical erosion of the capped mound, is also calculated for each historical storm using an appropriate model (in this case LTFATE is used). The response of interest is referred to as a response vector. During EST simulations, N-repetitions (say 100 or more) of T-year responses (say 100 to 200 years) of the response vector of interest (vertical erosion for capping projects) are produced providing mean value frequency relationships with accompanying confidence limits such that probability of occurrence can be defined with error band estimates. In other words, the mean vertical erosion for a range of return intervals with confidence limits (based on the number of standard deviations) are produced by the EST procedure.

Application of the EST to a capping project involves a series of sequential steps to calculate the cap erosion thickness. A description of these specific steps are provided in Appendix G, using the Mud Dump study mentioned above as an example. The remainder of this section summarizes the required steps and concludes with specific recommendations on how to translate frequency of erosion values into a cap erosion layer thickness.

To define the required cap erosion layer thickness as a function of depth at a specific site, the following procedure was developed. It consists of a site-specific quantitative analysis approach. First, an appropriate set of storms, both tropical and extratropical for east coast sites, and tropical for Gulf coast sites, have to be selected. Next, the hydrodynamic inputs (the time series of storm surge levels and tide elevations, their resulting currents, and wave heights and periods) for the selected storms have to be developed for input to an erosion model such as the LTFATE model. These inputs are often developed using a 3-D ocean circulation model such as ADCIRC (Luettich, Westerink, and Scheffner 1992) or CH3D (Scheffner et al. 1994).

After the water level, current, and wave data for specific storms are available and in the proper format, LTFATE can be run to calculate the thickness of the layer eroded by each storm for a range of capped mound configurations (elevations and cap materials). These data are then input into the EST program, which makes 100 or more simulations of mound erosion over a long time period (100-200 years). The results can then be analyzed with standard statistical techniques to produce frequency of erosion estimates for the various mound configurations tested. Finally, the frequency of erosion estimates, including expected annual erosion and the longer return period erosion estimates, are converted into a design erosion layer thickness.

The following paragraphs discuss the results of such a study and how these can be used to compute erosion layer thickness.

Recommended procedure for computing erosion layer thickness and selecting a design cap erosion thickness

This section describes a recommended procedure for computing the erosion layer thickness for open-water capping sites. Also provided is a discussion on how the erosion thicknesses can be used to select the design erosion thickness for the cap.

One of the primary outputs of a frequency of erosion study will be a series of curves similar to the one shown in Figure 28. This figure shows the return period frequency of a given amount of vertical erosion for a year of extratropical storms acting on a mound in the Mud Dump site with a base depth of 73 ft and an 8-ft-high mound for a crest depth of 65 ft. The solid curve is the mean erosion predicted based on 100 simulations; error bars define plus or minus one standard deviation. Values from the curve can be translated into a tabular form. For northeast coast sites that experience both tropical and extratropical storms, the values from both types of storm are combined into a single return frequency table, such as the one as shown in Table 6 generated for the Mud Dump site.

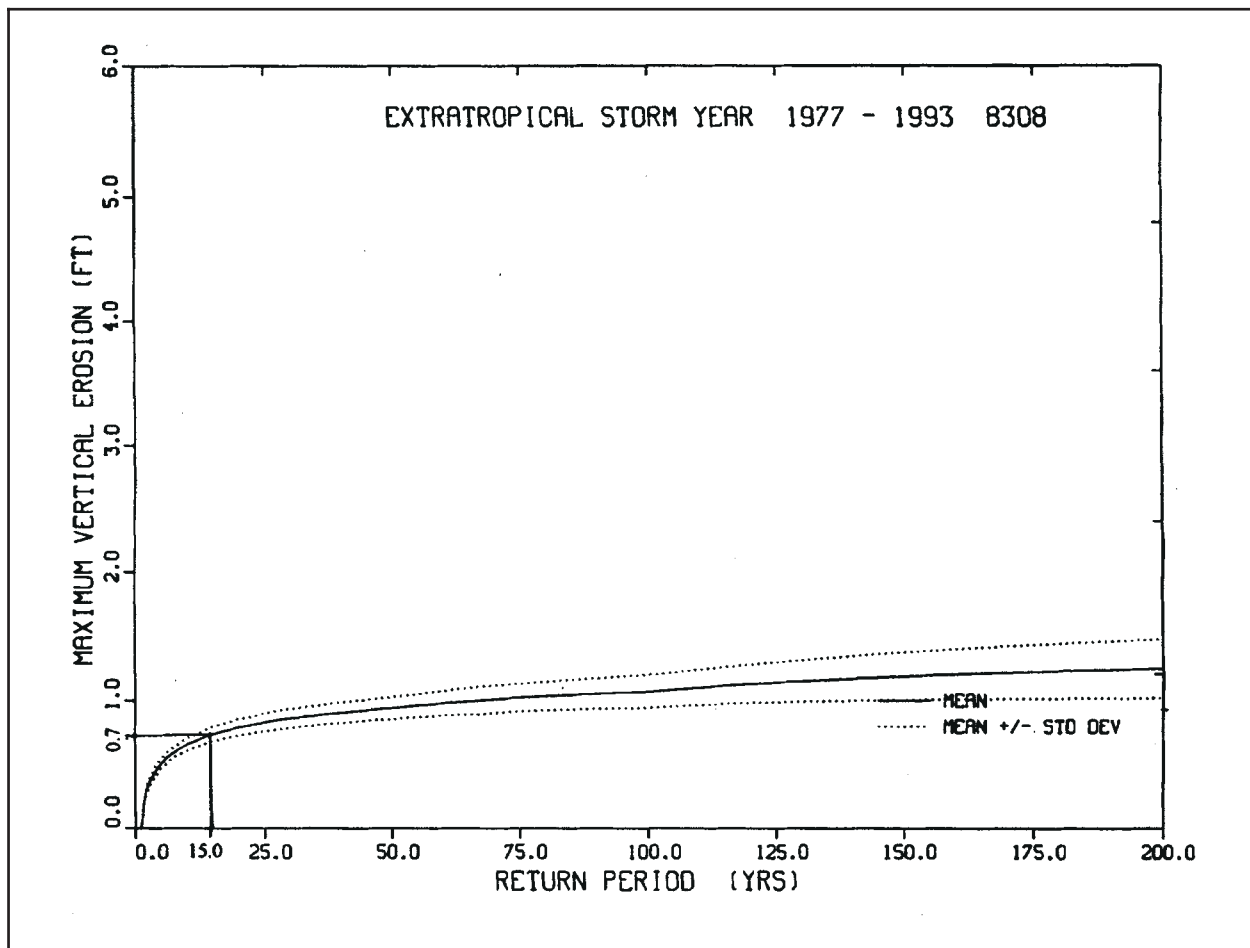

Figure 28. Frequency of vertical erosion from extratropical storms acting on a mound in Mud Dump site with a base depth of 73 ft and an 8-ft-high mound for a crest depth 65 ft

**Table 6
Episodic Erosion Thickness Estimates for Mud Dump Site for
0.4-mm Sand Caps**

Combined Hurrigan/Northeaster Single-Year Erosion Frequency, ft				
Base Depth/ Mound Height/ Crest Depth, ft	10 years	25 years	50 years	100 years
63/13/50	2.4	3.0	3.4	3.9
63/08/55	1.6	2.1	2.3	2.6
73/13/60	1.5	1.8	2.0	2.3
73/08/65	1.0	1.3	1.5	1.7
83/13/70	0.9	1.2	1.3	1.6
83/08/75	0.7	0.8	0.9	1.1

It is very important to note that the erosion values predicted by this curve and reported in the table are the maximum erosion experienced anywhere on the mound. Qualitatively, the maximum erosion is present over a very small portion of the mound, typically one corner on the seaward side (see Figure 29). Average erosion over the entire mound is expected to be much less, perhaps two-thirds of the maximum value, though this value will be a function of mound geometry, water depth, wave climate, and cap material and grain size.

In addition to maximum erosion expected from a severe storm year, the average-year cumulative erosion should be computed. To accurately compute average cumulative erosion, a time series of mound erosion resulting from typical storms (and nonstorm conditions if they are expected to produce erosion) over periods of between 5 and 10 years should be computed. During these model runs, the initial mound geometry would be impacted by a series of storms (or day-to-day conditions if warranted), with the resulting mound geometry from the previous storm becoming the input mound geometry for the following storm. Statistics on average and maximum erosion over the mound should be computed for time periods of say 1, 2, 5, and 10 years.

Using the above information on maximum episodic erosion thickness and cumulative annual erosion, the cap designers can then choose the return period erosion that provides the desired level of comfort or degree of risk. Factors that may influence the decision include the amount of uncertainty in the erosion prediction, the relative levels of annual versus episodic erosion, the level of contamination of the sediments being capped, whether or not additional material is expected to be placed on top of the project in the next few years, the difference in thickness required between a short and long return period, nearness of valuable resources/predicted consequences of the cap breaching, relative portion of the cap required for erosion compared with chemical isolation, bioturbation and consolidation, the unit/total cost of capping, difficulty in finding capping material and

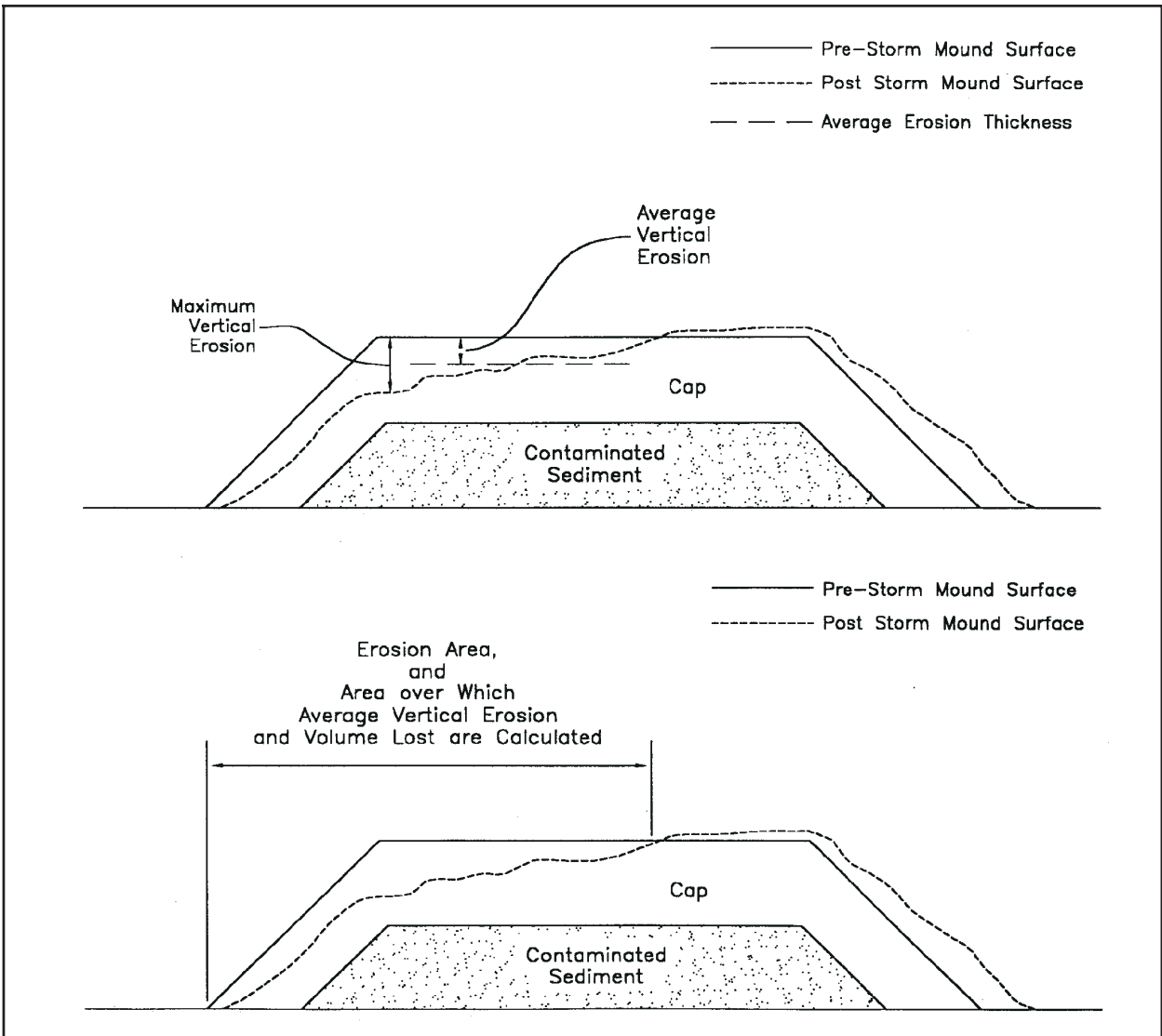

Figure 29. Idealized mound cross sections showing maximum and average vertical erosion and areas over which erosion volume is computed

gaining approval to cap, and other factors including political/social issues. Thicker erosion layers will reduce risk with a corresponding increase in cost.

The decision on the appropriate erosion layer thickness then will be site or region specific. For projects with minimally contaminated material where additional projects are expected in the next few years, a relatively short return period erosion thickness could be selected, say 10-20 years. Note that in Table 6, the erosion thickness for the 75-ft mound crest is 0.7 ft at a 10-year return period while the 100-year return period thickness is only 1.1 ft. For a mound at this depth, the designers may decide the extra protection provided by the additional 0.4 ft of cap is a good investment. However, for the 50-ft mound crest, the difference between the 10-year erosion thickness and 100-year erosion thickness is 1.5 ft (2.4 versus 3.9 ft), almost four times greater than at 75 ft. Therefore, if a

short-term cap is needed for a 50-ft mound, the designers might find a 25-year erosion thickness; 3.0 ft provides a reasonable tradeoff between risk and cost.

Another critical factor in selecting a design erosion thickness may be the cost and difficulty in finding capping material. For example, assume the project is one where the desire is to place a cap that would ideally never have to be repaired, or one for which the renourishment interval would be on the order of decades because of the difficulty and cost in obtaining additional cap material. For such a project, a fairly long period erosion thickness, say 100 years, might be selected (perhaps adding some additional thickness for annual erosion if it is significant). However, if the cost of such a project becomes too high and capping sand is relatively available, then a shorter return period thickness, say 30 to 50 years (without adding annual erosion rates), might be more acceptable.

As a starting point, past practice in engineering structure design provides some guidance. Many Corps projects are designed with 50-year lives. However, because a capped project is, at least for now, assumed to require maintenance for a considerably longer time, a 100-year erosion thickness seems to be a reasonable starting point. First, because of our limited knowledge of historical storm data, it is difficult to predict with confidence storm conditions for return periods much greater than 100 to 200 years. Second, providing a cap thickness sufficient to resist storms with intervals greater than 100 to 200 years would probably be much too expensive. For projects where additional material is likely to be added in the near future, a 20-year return erosion thickness seems to be reasonable. The thickness of the erosion layer should also be capable of withstanding multiple years of annual erosion; a minimum of 10 years is suggested for caps designed for a long-term cap.

Additional cap should be placed when the average thickness of the cap has been reduced such that the design year return period erosion thickness would also remove some to all of the cap thickness that accounts for bioturbation. This is suggested because it is expected that a major storm that causes significant amounts of erosion will also remove any established biological community that is able to bioturbate a significant thickness of material (typically 10 to 20 cm). It is also assumed that the thickness of cap lost in a major storm will be repaired prior to recolonization by significant numbers of organisms that bioturbate to a substantial depth (greater than 1 year).

Potential control measures for erosion

If cap erosion is considered to be a problem, armoring with larger diameter material (coarse sand, gravel, riprap) or geotextiles may be considered as engineering approaches to overcome or protect against this problem. Procedures for design of caps composed of nonsediment components is available in the EPA guidance document for in situ capping projects (Palermo et al. 1996).

9 Monitoring Considerations for Capping

Need for Monitoring

Monitoring of capped disposal projects is required to ensure that capping acts as an effective control measure (Palermo, Fredette, and Randall 1992). Monitoring is therefore required before, during, and following placement of the contaminated and capping material to ensure that an effective cap has been constructed. (This activity also may be defined as construction monitoring.) Monitoring should also be required to ensure that the cap as constructed will be effective in isolating the contaminants and that long-term integrity of the cap is maintained (This activity also may be defined as long-term monitoring).

Since capping is a control measure for potential benthic effects, the monitoring discussed here does not focus on water column processes or the water column contaminant pathway during the placement of contaminated material prior to capping. Also, this chapter does not focus on those aspects of open-water site monitoring pertaining to site designation or on the direct physical effects of disposal. Any such monitoring would be considered in the context of the overall site selection process (Palermo 1991b).

Design of Monitoring Programs and Plans

The design of monitoring programs for any project should follow a logical sequence of steps. Several excellent publications containing general guidance for monitoring in marine environments and specific guidance on physical and biological monitoring at aquatic sites for purposes of site designation/specification and for permit compliance are available (Marine Board, National Research Council 1990; Fredette et al. 1990a; Fredette et al. 1990b; Pequegnat, Gallaway, and Wright 1990). These basic references should be consulted in developing appropriate monitoring plans for capping projects that suit the particular site and material conditions. A capping-specific monitoring plan has been developed for the DAMOS program in the New England Division (SAIC 1995a); it has been

successful in evaluating capping success on over 20 capping projects to date (SAIC 1995a).

Fredette et al. (1990a) outlines five steps for developing a physical/biological monitoring program for open-water dredged material disposal. These steps as shown below should also be followed in developing a monitoring program for capping projects:

- a. Designating site-specific monitoring objectives.
- b. Identifying components of the monitoring plan.
- c. Predicting responses and developing testable hypotheses.
- d. Designating sampling design and methods (to include selection of equipment and techniques).
- e. Designating management options.

Fredette et al. (1990a) recommend prospective monitoring that consists of observations or measurements that determine if site conditions conform to a predetermined standard. In addition, unacceptable adverse effects or unreasonable degradation are defined before sampling is begun. This is in contrast to retrospective programs in which the magnitudes, types, and areal extent of adverse impacts are not defined until after sampling is underway and data are interpreted. The physical and chemical thresholds that result in undesirable biological responses or effects must be determined and the potential impacts of the disposal predicted.

The monitoring program should be multitiered, as suggested by Fredette et al. (1986), Zeller and Wastler (1986), and Pearson (1987). Each tier has its own unacceptable environmental thresholds, null hypotheses, sampling design, and management options should the thresholds be exceeded. These are best determined by a multidisciplinary advisory group whose technical advice is sought in organizing and conducting the monitoring program. A sample tiered monitoring program pertaining to capping projects is outlined in Table 7. Each of the steps in developing a capping monitoring program is discussed in more detail in the following paragraphs. Note that not all the monitoring techniques would necessarily be used at every site.

Monitoring Objectives

Setting attainable and meaningful objectives is a necessary first step in the design of any monitoring program/plan. Appropriate objectives for a capping-monitoring program/plan may include the following:

- a. Determine bathymetry, organisms, and sediment type at capping site.
- b. Determine currents for evaluating erosion and dispersion potential.
- c. Define areal extent and thickness of contaminated-material deposit to guide cap placement.

- d. Define areal extent and thickness of the cap.
- e. Determine that desired capping thickness is maintained.
- f. Determine cap effectiveness in isolating contaminated material from benthic environment.
- g. Determine extent of recolonization of biology and bioturbation potential.

Monitoring Program	Monitoring Frequency	Threshold	Management (Threshold Not Exceeded)	Options (Threshold Exceeded)
Consult site designation surveys, technical advisory committee, and EIS for physical and chemical baseline conditions.				
TIER I *Bathymetry *Subbottom profiles *Side-scan sonar *Surface grab samples *Cores *Water samples	Pre, Post Placement, Annually	*Mound within 5 ft of nav. hazard. *Cap thickness decreased 0.5 ft. *Contaminant exceeds limit in sediment or water sample.	*Continued to monitor at same level. *Reduce monitoring level. *Stop monitoring.	*Go to next tier. *Stop use of site. *Increase cap thickness.
TIER II *Bathymetry *Subbottom profiles *Side-scan sonar *Sediment profile cam. *Cores *Water samples *Consolidation instru.	Quarterly to Semi-annually	*Cap thickness decreases 1 ft. *Contaminant exceeds limit in sediment or water sample.	*Continued to monitor at same level. *Reduce monitoring level.	*Go to next tier. *Replace cap material. *Increase cap thickness. *Stop use of site.
TIER III *Bathymetry *Subbottom profiles *Side-scan sonar *Sediment profile cam. *Surface grab samples *Cores *Water samples *Tissue samples	Monthly to Semi-annually	*Cap thickness decreases 1 ft. *Contaminant exceeds limit in sediment or water sample. *Contaminant exceeds limit in tissue.	*Continued to monitor at same level. *Reduce monitoring level.	*Replace cap material. *Increase cap thickness. *Stop use of site. *Change cap sediment. *Redredge and remove.

Components of the Monitoring Plan

The components of the monitoring plan must be directly tied to the objectives and should include physical, chemical, and biological components to address the processes of concern. In identification of components and processes, it should be noted that biological responses are a direct result of physical and chemical alterations due to the disposal

operation. This fact provides a logical basis for establishing an appropriate tiered monitoring program that emphasizes physical monitoring in the lower tiers.

Physical processes of interest include the spreading and mounding behavior of the contaminated and capping layers during disposal operations, the potential erosion of these deposits due to currents and wave action, and the consolidation of the deposits and underlying sediment layers. Erosion and consolidation processes dictate the long-term thickness of the cap. The components of a monitoring plan needed to address these processes include periodic precision bathymetry, perhaps supplemented with SPC surveys, settlement plates, or other instrumentation.

Chemical processes of interest include potential mixing of contaminated material with the clean capping material during the construction phase, and perhaps in the long term due to bioturbation, and the potential migration of contaminants upward through the cap due to advection or diffusion. The components of the monitoring plan addressing these processes include sediment cores for chemical analysis of sediment or interstitial water to define the chemical profile of the contaminated and clean capping layers. Additional cores taken over time at the same stations would detect any upward migration of contaminants.

Biological processes of interest include type/quantity of organisms present and the potential for contaminant effects (i.e., toxicity and/or bioaccumulation) should contaminant migration occur or should the integrity of the cap be compromised. Components of monitoring that address these processes include sampling and analysis of benthic organisms that would colonize the site following completion of capping.

Developing Testable Hypotheses

Testable hypotheses must be established that are tied to critical threshold levels that, when exceeded, trigger a higher monitoring tier or implementation of a management action. Development of reasonable and testable hypotheses requires a prediction of the end result of the various processes that may occur at the site. A null hypothesis is developed (i.e., that there is no significant difference between predicted and observed conditions); if the threshold is exceeded, the null hypothesis is rejected. Tiers must be structured so that early warning of potential problems can be detected. Often physical monitoring may be the best tool in the lowest tier, but biological or chemical tools may have appropriate roles in the lowest tier as well. The key is to get relatively rapid, inexpensive, and interpretable results.

Construction Monitoring

Monitoring to ensure that placement occurs as designed may include baseline, postcontaminated material-placement, interim, and postcap material-placement surveys. Baseline surveys consist of determining the existing bathymetry of the site in order to determine changes in depth resulting from disposal. The postcontaminated material-placement monitoring determines where the contaminated sediments have been placed so that a final plan of cap-placement locations can be developed. Postcontaminated material-placement sampling is also needed as a baseline for cap-thickness determinations based on bathymetry. Interim surveys may be employed in large projects to determine where sufficient cap has been placed and where additional material should be placed. Finally, postcap material-placement monitoring is used to confirm the final cap thickness and to serve as a baseline for future monitoring efforts.

Monitoring for Long-Term Effectiveness

The principal long-term concerns for capped deposits are (a) whether the cap is remaining in place or whether erosion is occurring, and (b) whether the contaminants remaining within the contaminated layer are being transported to the sediment surface layer or to the water column. Erosion can occur either due to daily tidal currents, propeller wash, or as a result of storm-related surges or waves. Potential mechanisms for contaminant movement through the cap include pore water movement, diffusion, and biological mixing of the sediment (bioturbation).

Monitoring approaches for these concerns include sequential bathymetric surveys or diver-inspected settling plates to determine changes in deposit height, surface-sediment chemistry samples, sediment and pore water chemistry profiles from cores, sediment physical structure from cores, benthic community structure, and contaminant tissue concentrations of mound resident benthic species. These and other monitoring techniques discussed below can all be considered within the framework of a tiered monitoring plan and conducted on time intervals ranging from months to years.

After a severe storm, one with a 10- to 20-year return period, a modest monitoring program should be conducted to confirm the cap has not suffered any significant damage. Monitoring required after a severe storm should probably be limited to bathymetry, grab samples, and perhaps SPI and subbottom profiles.

Monitoring Techniques and Equipment

Selection of the types of samples or observations to be made, the equipment to be used, the number of samples or observations, etc., is

highly project dependent. Fredette et al. (1990b) contains guidelines on available equipment and techniques. Monitoring programs may only consist of physical measurements that include bathymetry, cap thickness, sediment physical properties (e.g., grain-size distribution and density), wave and current conditions, etc. Depth sounders, side-scan sonar and subbottom profilers, sediment sampling and coring devices, sediment profiling cameras, and instruments for measuring engineering properties of the sediment are required to make these physical measurements.

Navigation and positioning equipment are needed to accurately locate sampling stations or survey tracks in the disposal-site area. The accuracy requirements for monitoring are similar to those for placing the contaminated material and cap. See the discussion on navigation and positioning in Chapter 5.

Precision bathymetric surveys are perhaps the most critical monitoring tool for capping projects. Such surveys allow determination of the location, size, and thickness of the contaminated material mound or deposit and cap. A series of surveys should be taken before placement of contaminated material, immediately following (and perhaps during) placement of the contaminated material, and immediately following placement of the cap. The differences in bathymetry as measured by the consecutive surveys yield the location and thickness of the deposits. Because relatively small changes in mound elevation are of prime interest, highly accurate bathymetric surveys are required. Lillycrop et al. (1991) discuss interdependence of tidal elevations or bathymetry measurements and equipment capabilities and their effect on measurements. Acoustic instruments such as depth sounders (bottom elevations accurate to ± 0.6 ft under favorable conditions), side-scan sonar (mapping of areal extent of sediment and bedforms), and subbottom profilers (measures internal mound and sea-floor structure) are used for these physical measurements. Survey track spacing can be 50 to 200 ft depending on the areal coverage of the mound.

The attainable accuracy of bathymetric surveys limits the area and thickness of the deposit that can be detected. Limits of accuracy are governed by a variety of factors, which include accuracy of positioning systems, water depth, wave climate, etc. Engineer Manual (EM) 1110-2-1003 contains detailed information on hydrographic survey equipment and techniques and should be consulted in estimating the accuracy limitations of surveys. Other monitoring tools such as side-scan sonar, settlement plates, or SPCs must be employed to detect thinner deposits of contaminated and capping material.

Most methods for monitoring ocean-bottom depths from the ocean surface (air/water interface) are not accurate to within 20 cm. Waves bobbing the ship on which measurement equipment is attached, inaccuracy in local tidal elevation, and inaccuracy in latitude/longitude location add to the natural error of the instruments in measuring the bottom depth. In addition, the sediment/water interface is not clearly defined. During relatively quiescent periods, during which most measurements must be made, there is often a nephloid layer that blurs the sediment/water interface. This layer can be classified as bottom sediment with a high water content or water with a high sediment content. This

layer often creates “noise” on instruments measuring the bottom depths. Therefore, in addition to monitoring the mound from above, periodically, core samples should be extracted from different locations on the sediment mound to determine the thickness of remaining cap material. These cores should be extracted from those locations on the mound from which it is determined (by experience, surface measurements, and models) that most erosion occurs.

Bathymetric monitoring of deposits to determine sediment losses needs to be coupled with an understanding of consolidation processes. Consolidation that occurs in the cap, contaminated sediment, and the original base material within 6 to 12 months of disposal can result in substantial reductions in mound height (Silva et al. 1994; Poindexter-Rollings 1990) that could mistakenly be considered as erosion. Therefore, settlement plates are very useful.

The SPC is a tool that can be used to detect thin layering within sediment profiles. The SPC is an instrument that is lowered to the bottom and is activated to obtain an image of sediment layering and benthic activity by penetrating to a depth of 15 to 20 cm. As with bathymetric surveys, the SPC approach also has limits in its ability to detect the extent and thickness of deposits. The limiting depth of penetration limits the thickness that can be detected. However, SPC can be used in conjunction with bathymetric surveys to define the full range and extent of deposit thicknesses. The SPC is extremely effective for mapping the extent of the flanks of contaminated sediment around the central portion of the mound. Knowing their extent is critical to successful capping since these flanks can account for an area several times larger than that of the central mound and can include 20 to 40 percent of the sediment mass.

Sediment samples can be taken using grab samplers or coring devices to determine both physical and chemical parameters. In general, a core is required to sample the full thickness of a cap layer and the underlying contaminated material. Conventional boring techniques, vibracore samplers, and a variety of gravity coring devices may be suitable. However, site-specific factors such as the layering of the deposit (e.g., sand cap over relatively soft material), the material properties, and the capability of a coring technique to collect samples from such deposits should be considered when selecting a coring technique.

A variety of other instruments and approaches may be considered to gain needed information regarding the physical condition and processes occurring at capping sites. These include settlement plates (which must be monitored by divers), use of remotely operated instruments, or divers with photography and video cameras to obtain data on site conditions.

Biological monitoring may include sampling of fish and benthic organisms. Fish and many shellfish are mobile; therefore, data using these organisms are more difficult to relate to cause and effect. Sampling design using such mobile species needs to carefully consider effects of scale and migration dynamics. Most often, disposal mounds or sites are inconsequential with respect to the ranges of such species, and linking any observed changes in a species to disposal activities may be exceedingly difficult.

Benthic organisms are usually sedentary and often are considered good indicators of the effects of physical and chemical alterations of the environment. Benthic sampling devices include trawls, drags, box corers, and grab samplers. Trawls and drags are qualitative samplers that collect samples at the bottom interface, and therefore are good for collecting epifauna and shallow infauna (top few centimeters). Quantitative samples are usually obtained with box corers and grab samplers. Generally these samplers collect material representing 0.02 to 0.5 m² of surface area and sediment depths of 5 to 100 cm.

Detection of chemical gradients or changes in the distribution of contaminants within the mound can be monitored, but requires an understanding of the baseline heterogeneity of contaminants within both the contaminated deposit and the cap. For example, the contaminant concentrations within the contaminated deposit can be expected to range from hot spots to values that are similar to or even below the concentrations within the cap. This is reflective of typical heterogeneity within the original deposit and cleaner underlying layers of the channel or harbor. Thus, while it may be possible to detect large transitions, gradients may be much more difficult to observe, particularly if surface contamination existed within the channel prior to dredging.

Sampling of tissues of marine biota that colonize the mound also needs to be carefully considered. Typically, the chemical analyses require about 15 to 30 g (wet weight) of tissue per replicate. Unless the particular region has large-bodied resident species that are easily collected, it may take a day or more of field collection per station to obtain the necessary sample requirement. Tissue sampling is also complicated by the natural variation of benthic populations in both space and time. In some years, the target species may be very abundant, while in other years the species can be rare. These factors can result in large monitoring costs or produce data that are of limited value.

Designating Management Actions

When any acceptable threshold values are exceeded, some types of management actions are required. The appropriate management actions should be determined/defined early in the disposal planning process; they should not be determined after the threshold values have been exceeded.

Management options in early tiers could include increasing the level of monitoring to the next tier, the addition of more sediment to form a thicker cap, or stopping use of the site. Management options in later tiers could include stopping use of the site, changing the cap material, or the addition of a less porous material in cases where contaminant transport due to biological or physical processes is occurring. For caps that are experiencing erosion, additional cap can also be added, although it may be advisable to choose a coarser material (coarse sand or gravel) to provide armoring. In cases where extreme problems are encountered, removal of the contaminated material and placement at another site could be considered.

10 Case Studies

Subaqueous capping of contaminated dredged material in open-water sites began in the late 1970s, and a number of capping operations under a variety of disposal conditions have been accomplished. The Corps has conducted over 20 capping projects, with the majority conducted by the USACE New England Division (NED). An overview of the field experiences related to capping of contaminated dredged material is found in Table 8. Projects have included sites in Central Long Island Sound, New York Bight area at the mouth of the Hudson River, Puget Sound, and Rotterdam Harbor, the Netherlands. Data on capping projects vary widely in their availability. The projects listed in Table 8 are not intended to be all inclusive, but are representative of a range of site and operational conditions. Brief descriptions of most of these projects and others are given in the following paragraphs.

Long Island Sound

Capping is an alternative frequently used by the NED for disposal of material dredged from numerous industrialized harbors in New England. NED has documented the operations and monitoring programs in the Central Long Island Sound (CLIS) disposal site and other sites as a part of the Disposal Area Monitoring System (DAMOS). The DAMOS program was initiated in 1977, and the experience gained from 15 years (1979-94) of DAMOS capping experience is described in a series of DAMOS technical reports, many of which describe operations involving capping. The capping experience gained by NED in the CLIS disposal area has recently been summarized in a monograph (SAIC 1995) from which some of the information presented here is taken. Other capping experience gained by NED in the New London disposal site can be found in DAMOS reports and SAIC reports.

Over 15 years of disposal site monitoring of capped mounds in New England have provided an important data set of sufficient duration to allow evaluation of the long-term effects of capping contaminated dredged material. The data set includes a broad spectrum of characteristics including physical, chemical, and biological components. Future capping projects can benefit from the lessons learned in these pioneering projects.

Table 8
Summary of Selected Capping Projects

Project		Contaminated Material			Capping Material				
Location (Date)	Site Name and Characteristics	Volume $\text{yd}^3 \times 10^3$	Dredging Material	Placement Method	Volume $\text{yd}^3 \times 10^3$	Cap Thickness ft	Placement Method	Positioning Method	Literature Source
Duwamish Waterway Seattle (1984)	Existing subaqueous depression 70 ft deep	1.1	Clamshell	Scow (sand)	3.6	1-3	Sprinkling from scow	Surveying instruments	Truitt 1986b Sumeri 1984
Rotterdam Harbor Netherlands (1981-1983)	Phase I Botlek Harbor excav to 98 ft deep	1,200	Trailing suction hopper	Pump-out submerged diffuser	— (clay)	2-3	Scow, then leveled over site	Surveying instruments	d'Angremond, de Jong, and de Waard 1986
	Phase II 1st Petro. Harbor excav to 80 ft deep	620	Matchbox suction	Pipeline submerged diffuser	— (clay)	2-3	Scow, then leveled over site	Automated dredge/suction head positioning equipment	d'Angremond, de Jong, and de Waard 1986
Hiroshima Bay, Japan (1979-1980)	Contaminated bottom sediment overlaid in situ with capping material 70 ft deep	N/A	N/A	N/A	— (sand with shell)	1.6	Conveyor to gravity-fed submerged tremie suction pump-out thru submerged spreader bar	Surveyed grid and winch/anchor wires	Kikegawa 1983 Togashi 1983
New York Bight (1980)	Generally flat bottom 80-90 ft deep	860 (mounded to 6 ft thick)	Clamshell	Scows	1,800 (majority fine sand)	avg: 3-4 max: 5-9	Scow, hopper dredge	Buoy, real-time navigation electronics	Freeland 1983, Mansky 1984, O'Connor and O'Connor 1983, Suszkowski 1983
Central Long Island Sound Disposal Area (CLIS) (1979)	Stamford-New Haven North, flat bottom 65 ft deep	34 (mounded to 3-6 ft thick)	Clamshell	Scows	65.4 (sand)	7-10	Hopper dredge	Buoy, LORAN-C coupled positioning system	Morton, Parker, and Richmond 1984; O'Connor and O'Connor 1983
CLIS (1979)	Stamford-New Haven South, flat bottom 70 ft deep	50 (mounded to 4-6 ft thick)	Clamshell	Scows	100 (cohesive)	13	Scow	Buoy, LORAN-C coupled positioning system	Morton, Parker, and Richmond 1984; O'Connor and O'Connor 1983

(Continued)

Project		Contaminated Material			Capping Material				
Location (Date)	Site Name and Characteristics	Volume yd ³ × 10 ³	Dredging Material	Placement Method	Volume yd ³ × 10 ³	Cap Thickness ft	Placement Method	Positioning Method	Literature Source
CLIS (1981)	Norwalk, generally flat bottom 65 ft deep	92 (multiple mounds 8-12 ft thick)	Clamshell	Scows	370 (silt and sand)	6-7	Scow	Buoy	Morton, Parker, and Richmond 1984; O'Connor and O'Connor 1983
CLIS (1982-1983)	Mill-Quinnipiac flat bottom 65 ft deep	40	Clamshell	Scows	1,300 (silt)	Multiple broad area placement estimated final avg 6-10	Scow	Buoy	Morton, Parker, and Richmond 1984; O'Connor and O'Connor 1983
CLIS (1983)	Cap Site No. 1 generally flat 60 ft depth	33 (mounded 3 ft thick)	Clamshell	Scows	78 (silt)	Incomplete coverage	Scows	Buoy	Morton, Parker, and Richmond 1984; O'Connor and O'Connor 1983
CLIS (1983)	Cap Site No. 2 generally flat 56 ft deep	40 (low mound 2 ft thick)	Clamshell	Scows	40 (sand)	Irregular maximum 4.5	Scows	Buoy, LORAN-C	Morton, Parker, and Richmond 1984; O'Connor and O'Connor 1983
CLIS (1989-1990)	S-90-1 Harbor Village/Branford River generally flat 60 ft deep	37.6			102.7	Incomplete coverage; several distinct capped mounds 0.6 to 2.0 ft thick	Scows	Buoy	SAIC 1995b
CLIS (1993-1994)	CLIS-NHAV 93 New Haven Harbor generally flat 60 ft deep	561.5	Clamshell		665.2		Scows	Taut-wire buoy	NED files
New London Disposal Site (1988-1989)	Generally flat 54 ft deep	17.4 (2.3 ft thick)		Scows	77.8—scow 28.3—hydro surveys	0.3 to 2.6 ft thick			SAIC 1990
Portland Disposal Site (1991-1992)		17.4			70.3				SAIC 1996

Four LBC projects are the focus of the SAIC (1995a) report, and they all were conducted in the CLIS disposal site. The four NED projects (Stamford-New Haven, Mill-Quinnipiac River, Norwalk, and Cap Sites 1 and 2) are located within the boundaries of the CLIS disposal site, which is an area of 2 nm² located approximately 6.2-miles south-southeast of New Haven, CT, in water depths between 56 and 82 ft (Figure 30). Baseline data sets had previously been collected and were available for use in the capping projects as described in SAIC (1995a). Two other recent capping projects not discussed in SAIC (1995a), Harbor Village-Branford River (CS 90-1) and New Haven (CLIS-NHAV 93), have also been conducted in CLIS.

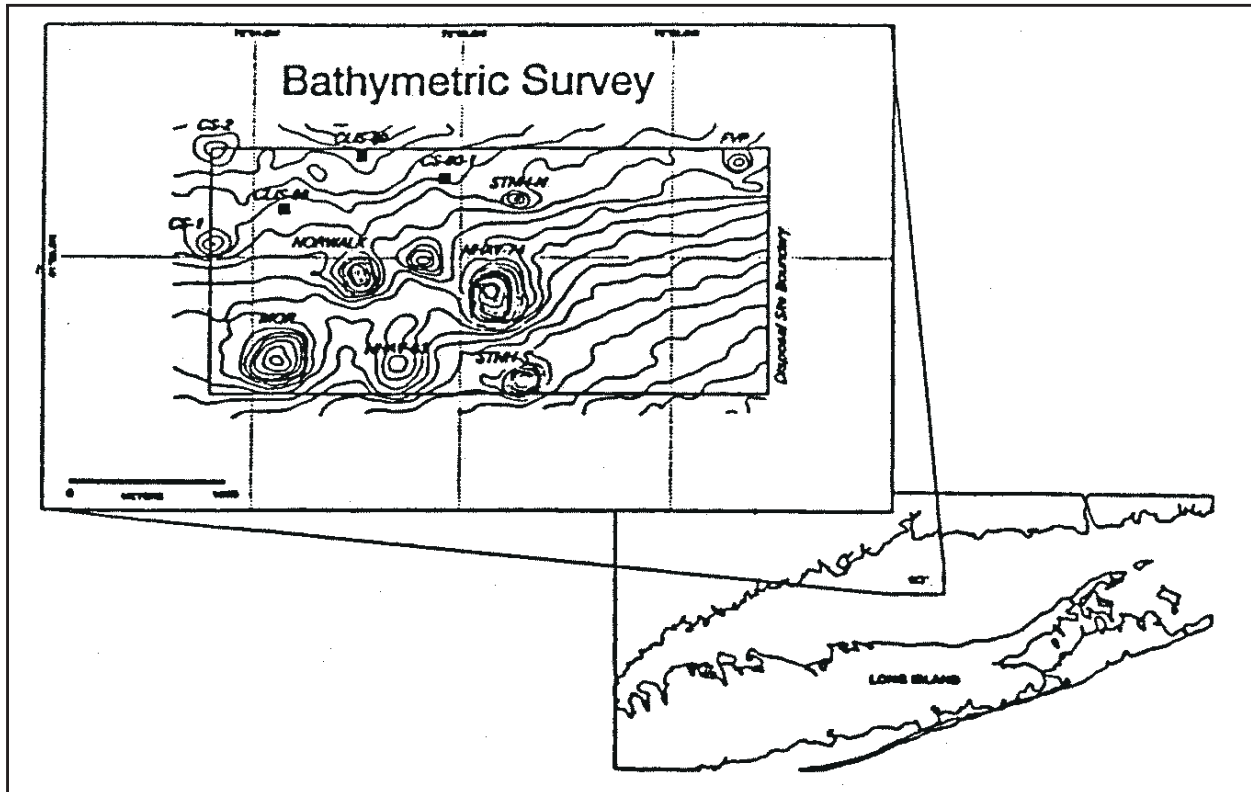

Figure 30. Central Long Island Sound disposal site (SAIC 1995a)

The Stamford-New Haven project was the first planned capping project at a subaqueous site in United States coastal waters. This project involved disposal of contaminated material from Stamford Harbor followed by capping with slightly less contaminated material from New Haven Harbor at two sites within CLIS. The success of the 1979 Stamford-New Haven project led to increased use of capping in New England under the DAMOS program.

The Stamford-New Haven North and South (STNH-N and STNH-S) and the experimental Cap Site 2 (CS-2) were the most successful of the early capped mounds. Bathymetry and SPC data showed that the contaminated material was thickly covered with capping material from the center to the outside radii. Point dumping of mound material and subsequent

placement of the cap material over the mound accomplished with the aid of a taut-wired buoy and accurate navigational controls proved to be successful. The stability of these mounds has been tested by 11 years of monitoring and the passage of Hurricane David in 1979, although the hurricane's passage was coincident with the predicted exponential compaction phase of the mound, and Hurricane Gloria (Fredette et al. 1989). It is desirable for the mound/cap formation to occur well before any storm windows in order that natural settlement and compaction has time to occur. All three mounds showed normal biological recolonization rates in subsequent monitoring. Sediment chemistry data show the surface sediment remained at or below background concentrations of the contaminants measured. Coring data show a clear visual and chemical boundary in many of the cores.

The historical record of the successful capping of the STNH mounds and CS-2 provided comparative insight as to why other capping projects were not as successful. For example, accurate placement of dredged sediments is less reliable without the use of both a buoy and an accurate navigation system, and their lack of use was attributed to the offset of the cap and mound at CS-1. The Mill-Quinnipiac River mound (MQR) demonstrated the importance of controlling operational factors and maintaining vigilant monitoring. Biological monitoring at the MQR showed subnormal recolonization rates relative to the other CLIS mounds. The disposal operations that included the Mill-Quinnipiac River and Black Rock and New Haven harbors were not conducted as distinct mound and cap depositional phases. The overlapping cap/mound deposition may have affected the recolonization rate at MQR. Similarly, the Norwalk mound was not formed in distinct cap and mound operations. The contaminant concentrations for both the mound and cap at Norwalk were well below those of Black Rock and MQR, and there was no evidence of adverse effects due to disposal operations at Norwalk in subsequent monitoring. Sediment chemistry results from MQR show that the surface chemistry of the mound was not similar to Black Rock sediments; instead, concentrations were at the high end of the range of most constituents analyzed in New Haven sediments. However, these monitoring results have allowed NED to detect and take corrective management actions.

During a 1993 NED capping project, maintenance sediments from New Haven Harbor and private terminals were placed in the CLIS. A total of approximately 500,000 yd³ of contaminated material was dredged from New Haven Harbor and private terminals followed by capping with about 660,000 yd³ of cap materials. Placement of the contaminated sediments was controlled with a taut-wire buoy, while a total of 18 separate placement points (using LORAN-C) were specified for the cap placement. Throughout the cap placement process, continuous monitoring allowed for adjustment of disposal points to optimize cap coverage and avoid point dumping.

The unique aspect of this project was that the mounds created from five previously placed projects were used to make a bowl in which to place the 500,000 yd³ of New Haven sediments (Fredette 1994). At the center of the bowl, the depth was 62 ft, while the surrounding depths were generally 0.6 to 10 ft shallower. Surveys showed that the planned depression was

successful in reducing the spread of the contaminated sediments and thereby significantly reduced the volume of capping sediments required.

The CLIS experience has provided insight on the procedures that historically are recommended for a successful capping project. In the pre-project planning, it is recommended to (a) completely characterize the sediments to be disposed including sediment chemistry, bioassay, or bioaccumulation data and classify sediments using most recent information; (b) estimate volumes of material to be disposed; (c) conduct site surveys and choose a disposal area that is not vulnerable to natural or anthropogenic erosion; (d) schedule dredging and disposal operations ideally to complete mound and cap well before a storm season to allow for consolidation and surface stabilization; and (e) dispose the cap materials as soon as possible after contaminated material. For the disposal operations, it is recommended to (a) employ both accurate navigational techniques and a taut-wired buoy to locate the designated disposal mound; (b) point dump mound materials by directing the barge to unload as near to the buoy as possible; (c) dispose approximately one-third of the cap sediments along the radius of the contaminated mound; (d) maintain the preproject plan for mound deposition followed by cap deposition; and (e) keep good records of all disposal operations.

New York Bight

Experimental Mud Dump (EMD) mound

An evaluation of the 1980 LBC project at the Experimental Mud Dump (EMD) site at the New York Bight apex (Figure 31) was reported by O'Connor and O'Connor (1983), and excerpts from their report are used to summarize this capping project. Contaminated dredged material from the Hudson Estuary, Newark Bay, and contiguous waters were capped initially with fine sediments from the Bronx River and Westchester Creek and followed with sand from the Ambrose Channel. The resulting cap was a 1-m-thick layer of sand overlaying contaminated sediment. Biological, chemical, and physical investigations were completed to evaluate the ability of the cap to remain intact and reduce the loss of organic and inorganic toxicants from the contaminated material to the surrounding water.

Results showed the cap was successfully placed at the experimental dump site, and it remained intact after 16 months. Erosion of the cap was minor, and predictions of cap life were in excess of 20 years under normal environmental conditions. However, it was predicted that major storm events were capable of causing cap erosion and exposing the contaminated material. The contaminated material volume decreased by 4 percent over the 16-month study due partly to consolidation and partly to losses during the disposal operation. Contaminant levels in the sand cap as measured by chemical analysis were shown to be lower than those in contaminated sediments. Bioaccumulation investigations indicated that contaminant uptake was less than at uncapped dredged material sites. Therefore, it was concluded that the New York Bight EMD capping project was successful

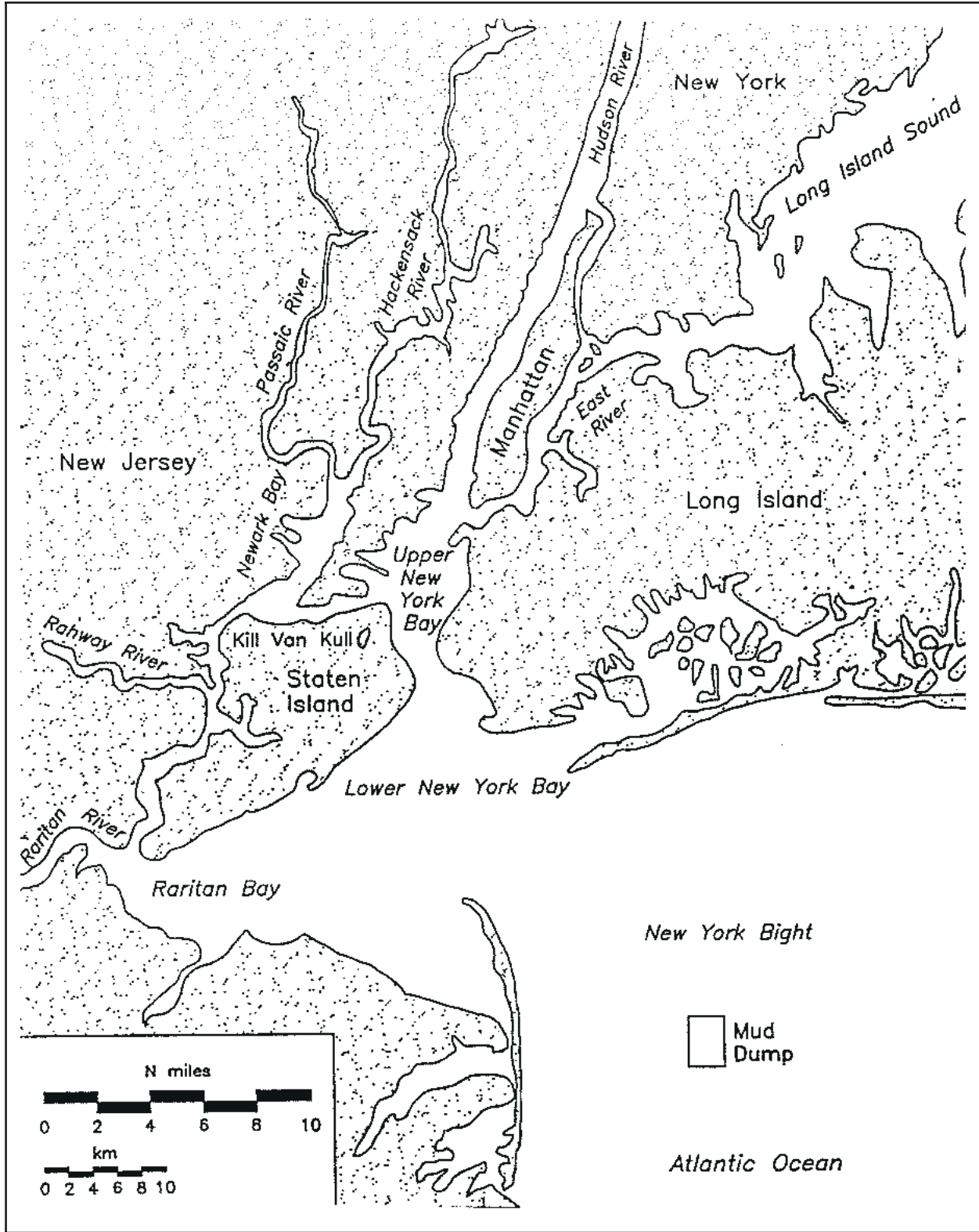

Figure 31. Mud Dump site in New York Bight (O'Connor and O'Connor 1983)

and capping can serve as an alternative to the control of contaminants in dredged material. The thickness and stability of the cap reduced the losses of contaminants to the surrounding water. It was recommended that capping be integrated with routine disposal operations to efficiently cover and isolate contaminated material at designated disposal sites.

In 1986 a detailed survey of the EMD mound was conducted to evaluate long-term stability of the mound (Parker and Valente 1988). Results of the survey, which included precision bathymetry, subbottom profiling, and SPI imagery, indicated the sand cap has not experienced significant erosion.

Port Newark/Elizabeth project

In June and early July 1993, 450,000 m³ of maintenance sediments contaminated with low levels of dioxin from the Port Newark/Elizabeth complex (part of the larger Port of New York-New Jersey), and last dredged in 1990, were dredged and placed in the Mud Dump site (MDS) (Figure 31). The maintenance material was subsequently capped (July 1993-February 1994) with 1,900,000 m³ of sand from Ambrose Channel. This project was preceded by several years of controversy due to the dioxin contamination (May, Pabst, and McDowell 1994; McDowell, May, and Pabst 1994; Greges 1994). Concerns about cap stability were based on erosion within the MDS that occurred after a severe northeaster in December 1992 (McDowell, May, and Pabst 1994). Erosion thicknesses greater than 1 m occurred from portions of the flanks of recently placed fine-grained maintenance material. These concerns led to a study (Richardson et al. 1993) that concluded that a mound with a 0.4-mm sand cap with an upper crest limit at a depth of 23 m (75 ft) should be stable (i.e., experience minimal erosion) during a storm comparable with the December 1992 storm.

The upper cap elevation limit of 23 m combined with the large volume of material and limited space available resulted in the design of a triangular-shaped mound as shown in Figure 32. Water depths at the site of the planned disposal ranged from 24 to 25.3 m. A design requirement to provide a 1-m cap over the mound restricted the planned elevation of the contaminated mounds to approximately 1.5 m.

Readily available geotechnical data on the contaminated sediments were limited to percent sand, silt, clay, and percent moisture (average values were 6, 58, 35, and 52 percent, respectively).

The contaminated material was removed using mechanical dredges; no overflow was allowed. Dredged material was placed in bottom-dump scows ranging in capacity from 1,900 to 4,600 m³ and transported to the MDS. A total of 149 loads were placed over a 5-week period. The permit required the barge operators to place material within the 150-m-wide by 350- to 450-m-long disposal lanes on a rotating basis (Figure 32). To assist the contractor in siting the placements, the apex's of the triangle had taut-moored buoys. To reduce the chance of placing material outside the lanes, the contractor was directed to dispose of all material within 60 m of an imaginary line connecting the apex buoys. Calibrated LORAN-C positions for the tugs with offsets to correct for the location of the center of

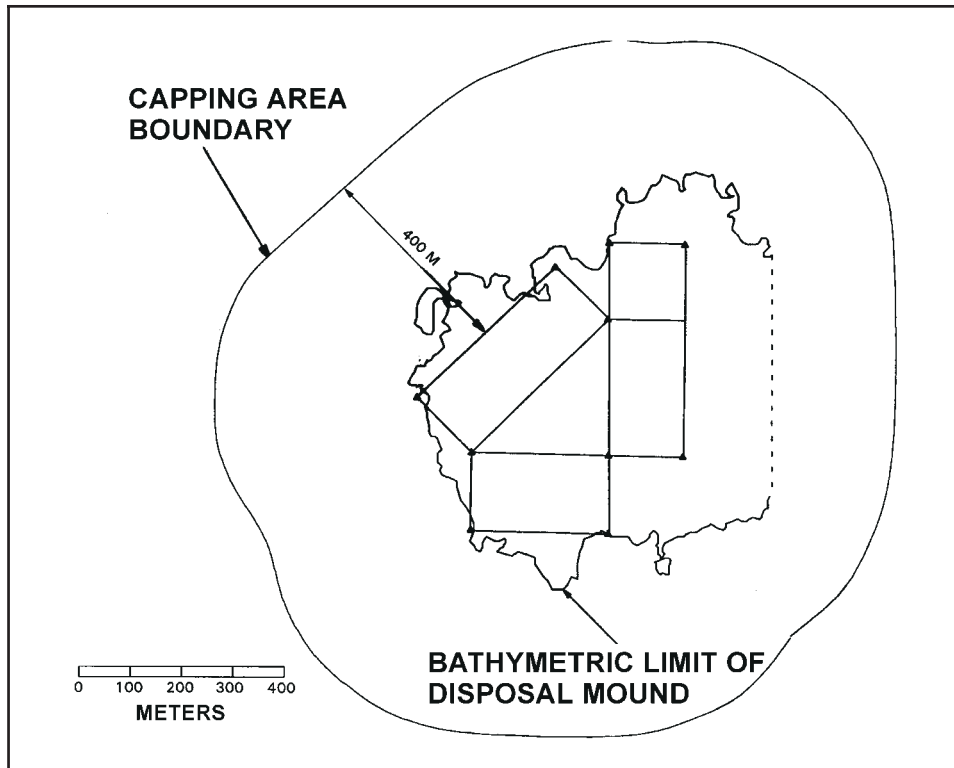

Figure 32. Port Newark/Elizabeth mound limits

the barges were recorded. Barge speed during placement was 0.5 to 1.5 m/sec. To help prevent mounding at the point of release, the barge operators were directed to crack the hull part way resulting in a disposal time of 30 sec to 1 min, and were also directed to enter the disposal lanes from opposite ends on alternate placements.

Apex buoys were installed using calibrated LORAN-C so they could be quickly reset. LORAN-C was calibrated with short-range microwave readings at known points within the harbors.

A bathymetric survey conducted during mound construction indicated the contaminated material mound was exceeding the desired 1.5-m height limitation in some locations. This combined with the Port's request to increase the amount of material dredged altered the disposal lane pattern to include additional placement in the center of the triangle and the addition of a 150- by 150-m square area at the north end of lane AB (Figure 32).

The final postcontaminated mound bathymetry survey showed that a roughly triangular mound had been formed as designed. As might be expected, individual mound peaks were evident (generally located at the ends of the lanes), which projected above the average mound thickness over the area of about 1.3 m. The peaks ranged in elevation from 1.5 to 2.4 m. Average side slopes (from the edge of the mound crest down to the 0.2-m contour) on the outer sides of the mounds were about 1:45.

The final overall dimensions of the contaminated sediment mound, as defined by the 0.3-m contour, were approximately 630 m in the north/south direction and 645 m in the east/west direction. If the 0.15-m contour is defined as the edge of the main mound, then the mound dimensions increase to approximately 745 m in each direction as shown in Figure 32. SPI surveys of the contaminated sediment apron showed the apron extended out approximately 400 m in each direction beyond the outer edge of the disposal lanes, creating a roughly circular area to be capped with an average diameter of 1,370 m (4,500 ft) (Figure 32).

Based on nine SPC transects with three to six stations per transect that contacted the apron, the average thickness was about 3 to 5 cm. On some transects, the thickness decreased regularly out from the mound, while on others the variation was more random. The native bottom was visually distinct, allowing a visual resolution of a minimum thickness of contaminated sediments of 1 to 2 cm. Thus, the edge of the apron was defined as areas with less than 1- to 2-cm thickness of dredged material.

Prior to the start of the capping operation, New York District and EPA Region II staff decided to cap the contaminated mound including the apron with 1 m of sand. This required what was initially estimated as 1,500,000 m³ of sand to cap the area shown in Figure 32. On 11 July 1994, hopper dredges began placing cap material, 0.4 mm sand from Ambrose Channel, over the contaminated sediments. At least two intermediate surveys and additional capping were required before capping was completed in February 1994, when an estimated total of 1,870,000 m³ of sand had been placed covering the entire contaminated footprint with close to a meter or more of sand. The additional 370,000 m³ (480,000 yd³) over the original estimate (a 25-percent increase) was due to the requirement to provide a 1-m cap everywhere as opposed to an average of 1 m. Capping the contaminated main mound as defined by the 0.15-m contour with 1 m of sand would have required an estimated volume of approximately 450,000 m³. If instead of the 1-m cap placed over the apron, a 0.30-m cap had been placed over the apron, it would have required an estimated 308,000 m³, for a total cap volume of 758,000 m³. Increasing that total by 25 percent to provide a minimum 1-m cap over the main mound and a 30-cm cap over the apron would have brought the total to 940,000 m³, or approximately half the amount actually placed.

Due to concerns about the possible adverse effects of contaminated sediment resuspension during the cap placement, EPA Region II required that the initial 15 cm of cap placed impact the bottom with as little downward velocity as possible (i.e., sprinkled at the individual particle settling velocity). This required modification of previous capping procedures routinely used where barge or hopper dredges perform conventional bottom dumping operations. Randall, Clausner, and Johnson (1994) discuss modifications made to the STFATE model (and now incorporated into the MDFATE model), based on experiments using planar laser-induced fluorescence (Roberts, Ferrier, and Johnson 1994), used to model cap placement.

The capping procedure consisted of using the spit-hull hopper dredges Dodge Island and Manhattan Island and the hopper barge Long Island discharging over predetermined lanes to cover the contaminated mound. The split-hull dredges “sprinkled” their average 2,000-m³ loads over a period

of 25 to 30 min while moving at an average speed of 3.0 to 3.7 km/hr with the hull cracked open 0.3 m. The Long Island pumped out its average 9,200-m³ load through over-the-side pipes with the slurry directed forward over a period of 2 to 3 hr while moving at 1.9 to 5.6 km/hr.

To uniformly place the material, the dredges followed a series of lanes 30 m wide that covered the contaminated sediment mound and apron. Turning requirements typically caused the hopper barge to move over four lanes after reaching the end of a lane. A series of straight-lane segments around the perimeter were also used to cover the outer edges of the project. Disposal-lane orientation varied over the duration of the project. Initially, the lanes started north-south; at later stages they were a series of straight sections around the roughly octagon-shaped perimeter of the project (Figure 33). Microwave positioning (with three shore stations) with an estimated accuracy of 3 m or better was used for navigation and positioning of the hopper dredges.

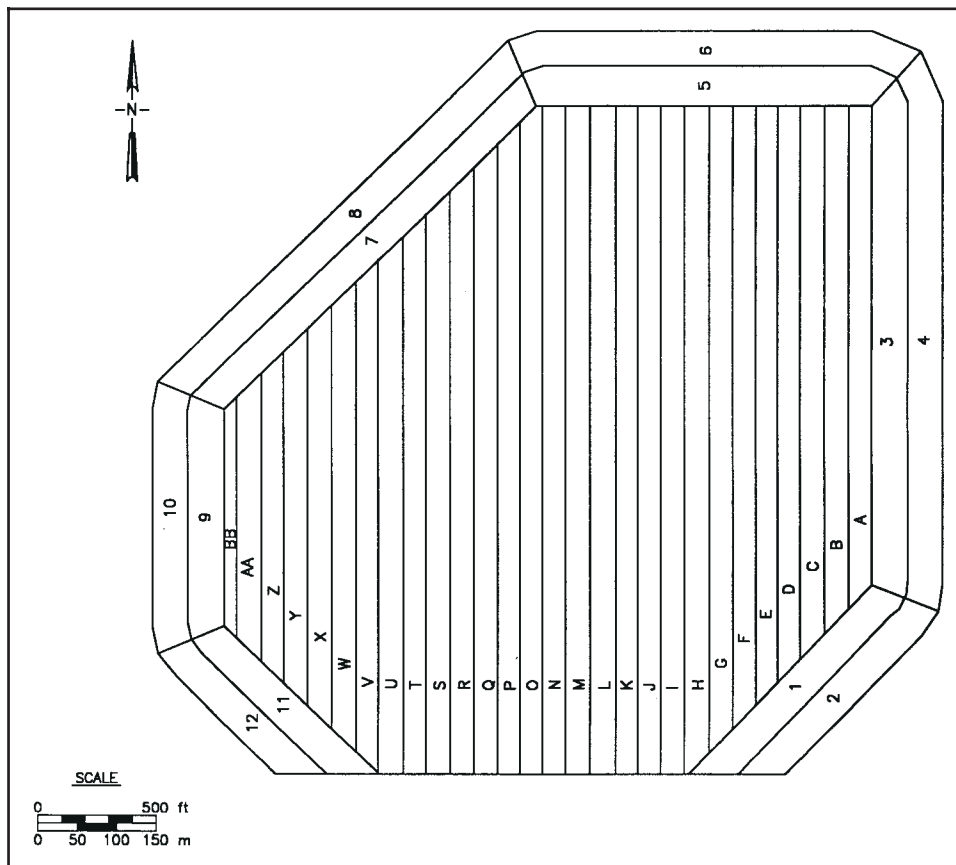

Figure 33. Disposal lanes used for placing cap material in Port Newark/Elizabeth project

Initial cap placement involved sailing long straight lines, 600 to 900 m long (with a turn at the end of each line). Cleanup operations, i.e., filling in small areas that have less than the required thickness, generally involved areas only about 100 m across. Placing sand in these small areas was much less efficient due to two factors. For the Long Island, maneuvering is very difficult, with 20 to 25 min required to turn the vessel

around and place it on an exact location at a specific heading. For the split-hull hopper dredges, problems associated with cleanup were due to the fact that once the hull is split, disposal of material continues until the hopper is empty, i.e., the split hull cannot be closed until the hopper is empty. Thus during cleanup, considerable amounts of sand end up being placed on areas adjacent to the cleanup locations that already have sufficient thickness.

After completing the project, the hopper dredges were found to have problems with sealing of the hoppers, possibly as a result of structural deformations due to long hours of sailing with the hull cracked.

Duwamish River Demonstration

The first CAD project in Puget Sound in the northwestern United States was in the Duwamish Waterway (Figure 34) as reported by Sumeri (1989). A shoal that limited navigation through the waterway was found to contain contaminated sediments that eliminated the possibility of unconfined open-water disposal. Thus, the Seattle District initiated a demonstration project to dispose of 840 m³ of contaminated material in a subaqueous depression in the West Waterway and to cap it with 3,220 m³ of clean maintenance dredged material from the upper Duwamish River (Sumeri 1984). The fine-grained contaminated sediment exited the bottom-dump barge as a slurry and descended rapidly to the bottom as a cohesive mass (convective descent). Three barges using survey positioning systems were used to place the sand cap by “sprinkling” sand at an average rate of 21 m³/min from incrementally opened split-hull barges. The resulting average cap thickness was 61 cm. The sprinkling procedure using conventional equipment minimized displacement of the contaminated sediment and hastened the consolidation process. Since the capping material was released slowly, it tended to settle to the bottom as individual grains and not as a contiguous mass. Vibracore sediment samples taken up to 5 years following capping showed the interface between the contaminated and cap sediments was sharp throughout the entire monitoring program. Measured contaminant concentrations were either absent or present in low concentrations in the cap material.

One Tree Island Marina

A CAD project involving direct mechanical placement of material was conducted in 1987 for the expansion of the One Tree Island Marina at Olympia, WA (Figure 34). The operation involved dredging of 2,980 m³ of contaminated material by clamshell with disposal in a deep conical pit dredged on the project site and capping with 2,980 m³ of clean material.

The dredging operation was conducted in somewhat crowded conditions with the project dimensions of 48.8 by 91.5 m situated between two other marinas (Figure 35). First, the contaminated layer overlying the location

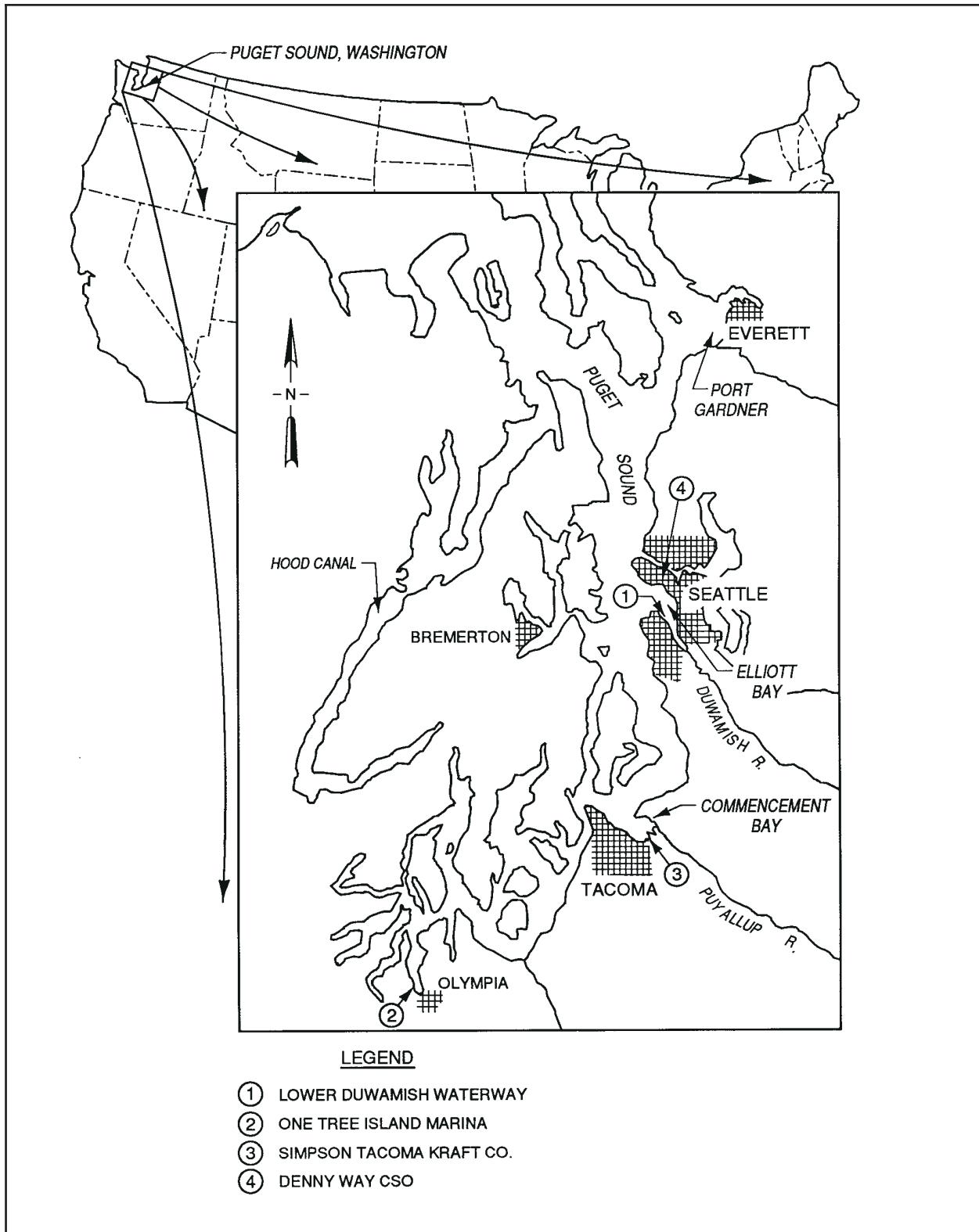

Figure 34. Puget Sound capping projects



Figure 35. One Tree Island Marina project

of the pit was dredged by clamshell into three barges. Next, the clean conical pit and additional clean material were dredged into an additional split-hulled barge and disposed at another deep-water site. The pit capacity was confirmed, and then the three barge loads of contaminated material were placed in the pit. Finally, more clean material was dredged by clamshell directly into the pit to provide the 1.2-m minimum cap over the contaminated sediment. During dredging, a 45-m dilution zone extending radially from the point of dredging was specified, and outside this area, local water quality standards were maintained. A monitoring program was conducted to evaluate the effectiveness of the cap.

Simpson Tacoma Kraft

In 1988, the Simpson Tacoma Kraft Company capped approximately 17 acres of in situ contaminated nearshore bottom area with 0.6 to 3.7 m of sand hydraulically dredged from the Puyallup River (Sumeri 1989). The contaminated bottom sediments were the result of 37 years of discharging untreated mill wastewater, log storage and chipping operations, and storm-water discharges. The site was a designated EPA Superfund site.

The Puyallup River material was predominantly medium sand with some clay and small fractions of fine and coarse sand and traces of gravel. This material was determined to be relatively clean by chemical and bioassay testing and suitable for capping. Twelve- and ten-inch (30.5- and 25.4-cm) hydraulic dredges were used to dredge approximately 152,910 m³ of capping material. This material was transported approximately 1 km through floating and submerged pipeline to a spud barge for distribution over the contaminated sediment area. A 2.4- by 4.3-m plywood diffuser box with

baffles and 15-cm side boards containing holes throughout was used to distribute the sand slurry over a wide area. This device essentially sprinkled the sand over the contaminated fine-grained sediment on the bottom. The spud barge and boom extension were swung about the spud and controlled by anchor lines. The cap was placed by swinging the plywood box (“sand box” as shown in Figure 7) back and forth until manual leadline soundings indicated the desired cap thickness was attained. Acoustic depth sounders were ineffective due to high sand load and entrained air in the water column. The barge was moved ahead 3.1 m providing a one-third overlap, and the swinging procedure was repeated. Subsequent movements of the spud barge and spreading of the cap material were made until the contaminated area was completely capped. Physical, chemical, and biological monitoring were initiated to determine cap effectiveness during the first 5 years following cap placement.

Denny Way

The Denny Way Combined Sewer Overflow (CSO) is located in the lower Duwamish River in Puget Sound (Sumeri 1989). It discharges both untreated sanitary sewage and stormwater runoff and acts as a relief point during peak storm events each year. The bottom sediments in the area off the Denny Way CSO (Figure 34) were found to be contaminated. Subsequently, a CSO control plan and source control activities were instituted to reduce the toxicant loading.

The in situ contaminated sediments at Denny Way were capped with sand using a similar procedure as used in the Duwamish capping project. For this project, sand placement needed to be more accurate. Clean sands were obtained from a maintenance dredging project and transported to the site by a bottom-dump barge. Placement of the cap was completed by pushing the barge sideways and sprinkling a 39-m-wide sand blanket. Barge displacement was measured with two pressure transducers installed in stilling wells at each end of the barge, and these displacement signals were telemetered to the microprocessor onboard the attending tug. The navigational position of the barge was tracked by a laser positioning system, which also telemetered the tugboat and monitored position and sand-sprinkling rate. A cap of 0.6 to 0.9 m was placed at the Denny Way CSO site, and monitoring of the cap effectiveness was instituted.

Port of Los Angeles/Marina del Ray

A large CAD project has recently been completed in the Port of Los Angeles (LA), and this project is the first to be implemented in California. The CAD site is constructed inside and adjacent to the main breakwater in LA Harbor and is known as the Permanent Shallow Water Habitat (PSWH) site. Materials placed in the site include contaminated materials from channel deepening within LA Harbor and contaminated materials from the Marina del Ray Project. Subaqueous dikes were first constructed using

suitable quarry run materials from Catalina Island. Contaminated sediments from the harbor were placed by surface release at the site. Materials from the Marina del Ray Project were placed at the site using geotextile bags, the first demonstration of this technology as an application for placement of contaminated dredged material.

The PSWH site was originally designed by the Port of Los Angeles as an environmental mitigation measure for the Pier 400 harbor development project. Site design called for filling the 190-acre area to raise the natural bottom from 40- to 45-ft depths to depths less than 20 ft, creating a shallow-water foraging area for the endangered California least tern. Quarried stone from Catalina Island was used for construction of the subaqueous berm (see Figure 36). Approximately 543,000 cu yd of contaminated material from the harbor were placed within the site. These sediments had elevated levels of contaminants and were considered unsuitable for open-water disposal and were also undesirable from the standpoint of placement in the Pier 400 engineered landfill.

The contaminated sediment was placed in the center of the 94-acre portion of the overall 190-acre site. The 94-acre area was laterally separated from the outer boundaries of the site by buffer zones ranging from 200 to 650 ft, all of which were slated for capping with clean material. The widest (650-ft) buffer was located on the breakwater side to ensure the contaminated sediments would remain isolated in the event of a rare catastrophic storm that might breach the breakwater. Approximately 4 million cu yd of clean material from the harbor, which was physically unsuitable for landfill construction, comprised the lower (thickest) layer of the cap. Clean sand was used for the final 2 ft of cap to resist erosion and provide suitable substrate for the tern habitat. Together, this resulted in a cap thickness generally exceeding 15 ft. Such a cap thickness is far in excess of that required for effective capping from the standpoint of containment and was dictated in part by site geometry and dredging volumes.

The sequence of material placement was also driven in part by the dredging requirements for the overall Pier 400 project. The placement of initial portions of contaminated material was by clamshell dredge. This material was placed in the “central area” of the PSWH, while other initial elements were mechanically placed in the “perimeter area.” The initial capping material was placed over the “central area” using a hopper dredge. The subsequent capping layers were placed by pipeline dredge.

Placement of a sand cover was completed after a waiting period of 11 months to allow for consolidating the fine-grained capping material and minimizing the mixing of sand with the fine material.

Prior to initiation of the Pier 400 project, the PSWH site was selected for placement of additional contaminated material from the Marina del Ray project located 35 miles from LA Harbor. This project involved approximately 55,000 cu yd of sandy contaminated sediments, which also contained potentially floatable debris. The initial scheduling of operations at Marina del Ray would have required placement of this material at the PSWH site prior to construction of the subaqueous berms. To avoid dispersion during placement and spreading of contaminated material in absence of the berms, the permit required use of geotextile bags for the

Marina del Ray material (Mesa 1995). Actual placement was initiated following completion of the berms, so the geotextile bags were not actually required as a control measure; but the project proved to be a valuable field demonstration of this innovative concept.

The sediments were dredged using a clamshell and placed in a split-hull scow lined with two layers of geotextile (a nonwoven inner liner and a woven outer shell) forming a container. Following completion of filling of a barge, the geotextile material was brought over the top of the barge, and the edges were sewn closed to form the completed container. Modifications were made to the scow bulkheads to reduce the width and length of the filled volume to allow easier release of the filled bags.

The first geocontainer was filled with approximately 1,900 cu yd of material. Because of drainage of the sandy sediment during transport and subsequent bridging action, the first container failed to fall completely from the barge. Water jets were finally employed to fluidize the material and release the bag. Subsequent bags were only filled with approximately 1,300 cu yd, and additional fabric was used in forming the containers, providing more “slack” in the containers to help with release. A total of 44 containers were placed (Figure 36).

All contaminated materials were successfully placed within the subaqueous dikes, and the dikes have performed as intended. Bathymetric and sediment profiling image camera monitoring confirmed that approximately 98 percent of the contaminated material was retained behind the subaqueous dike, and that the thickest deposits immediately outside the dike were generally less than 5 cm (the regulatory limit set for the project in advance).

Rotterdam Harbor

As a consequence of local effluent discharge from chemical industries sited around the 1st Petroleum Harbor in the Port of Rotterdam, the harbor basin contained heavily contaminated material. Several options (upland, open water, dredged pits, and confined behind a sheet-piled dam) were considered for disposing of the contaminated material as described by Kleinbloesam and van der Weijde (1983). The alternative finally selected was a CAD project that consisted of excavating pits in the 1st Petroleum Harbor, dredging the contaminated material, disposing of it in the pits, and capping and lining the pit with clean material (Figure 37). The plan, called the Putten Plan, had to be executed so that dispersion of pollutants into the surface water and groundwater was very low, but acceptable. Special dredging equipment was used for the disposal operation, and studies were conducted to determine the dispersion of the contaminants.

The first dredge pit was 550 by 120 m at the bottom and was 15 m deep with a capacity of 1.4 million m³. The silt from the pit dredging was disposed at sea, and the sand was used at various landfill projects. Two additional pits were dredged; the contaminated dredged material was taken to the first pit, and the clean material was used or discharged at sea. A third

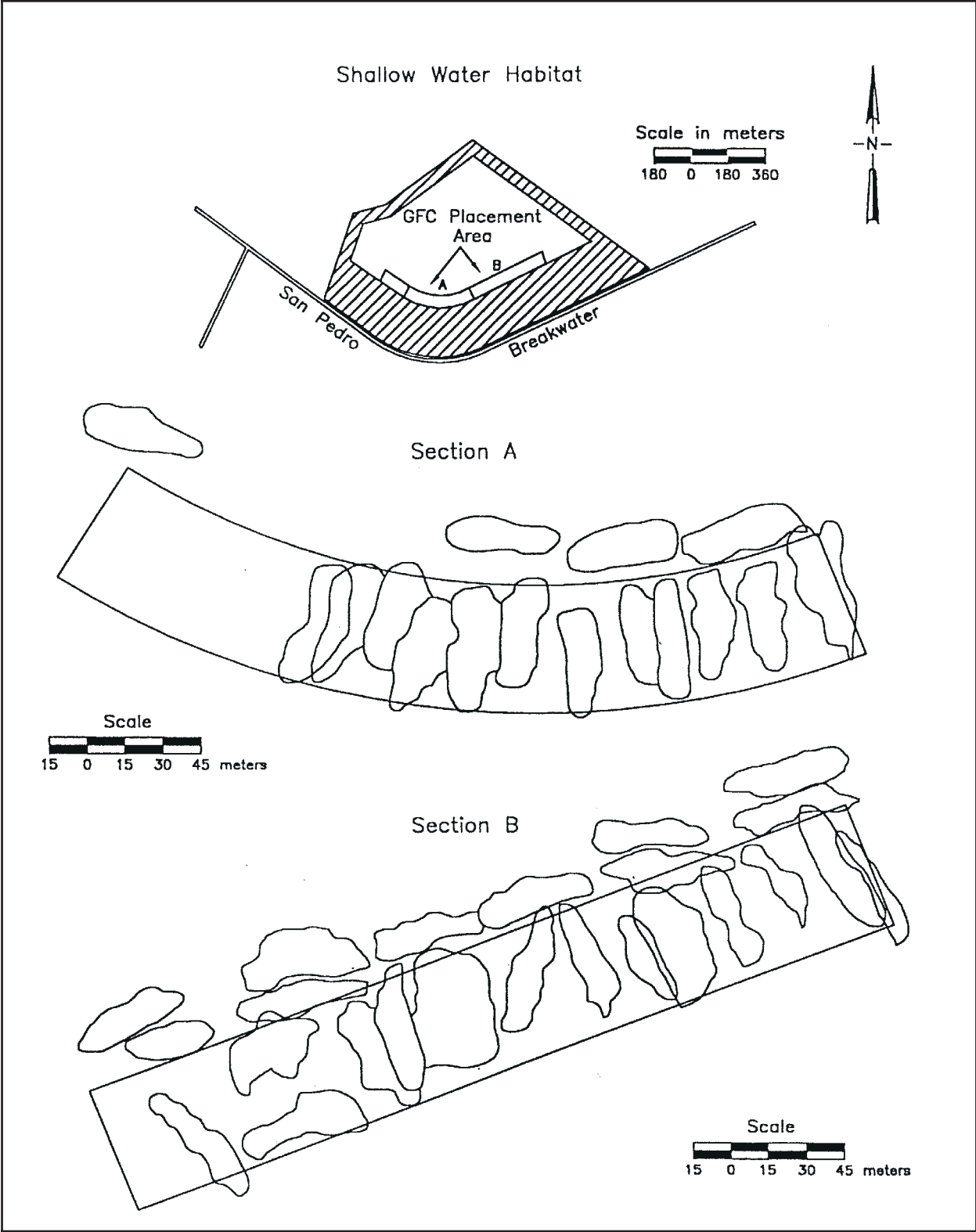

Figure 36. Marina del Ray project plan showing location of berms and geotextile bags

pit was needed to complete the disposal of all expected contaminated material. This procedure (Figure 37) was to be completed only once, and subsequent maintenance would be completed using normal methods.

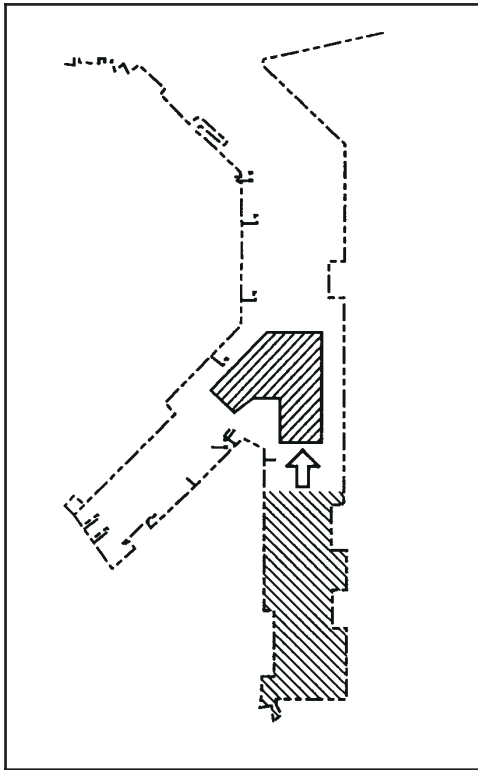

Figure 37. Rotterdam Harbor CAD project

A suction dredge was converted to act as the discharge vessel with the suction pipe used as the discharge pipe. Conditions on the suction dredge operation were (a) no overflow, (b) no water jets in suction process, (c) lower working speed, (d) must use onboard pumping systems for contaminated sediment discharge, (e) contaminated water from silt and degassification must not be discharged overboard, and (f) contaminated mixtures cannot be pumped overboard. The discharge pipe was extendable to 30 m and was equipped with a modified discharge opening (diffuser). The diffuser directed the discharge radially and reduced the exit velocity to between 0.3 and 0.4 m/sec. The dredge was also equipped with a degassification system. Contaminated material was dredged with a modified stationary suction dredge. Its suction mouth was equipped such that only the upper layer of the dredged material was touched, and the suction intake had no moving parts or waterjets. The objective was to maintain the in situ density of the dredged contaminated material throughout the dredging, transporting, and discharging operations. Pollution of the groundwater through the bottom of the dredge pit was

also of concern. After researching this problem, it was decided to place a layer of clay as a liner in the bottom of the dredge pit.

Hiroshima Bay

Hiroshima Bay in the Inland Sea of Japan was the site of bottom-sediment improvement testing using a special barge unloader sand spreader (Kikegawa 1983). The investigation demonstrated that the sand-overlaying process was successful using a barge unloader sand spreader (Figure 10), and the sand layer had only minor irregularities in thickness with a mean thickness of 0.5 m. Coarse particle size (0.1 to 10 mm) containing shells with silt content of 0.1 to 0.3 percent was used as the overlaying material. The discharge sand quantity during the spreading operation was estimated using the pump suction pressure. Bottom sediment resuspension during discharge was measured with a portable turbidity instrument, which showed the resuspension of the bottom sediment was up to 1.5 m above the seafloor. The depth of spreading did not cause any noticeable differences in the spreading capability. The sand spreading did result in turbulence in the bottom sediment, but contamination of the

surrounding water did not occur. The success of the sand-spreading demonstration was above expectations, but it was concluded that a new type of sand spreader would be needed for larger scale operations.

A conveyor barge (Figure 11) with 18 hopper bins was used in Hiroshima Bay for another sand-spreading test (Togashi 1983). The barge could discharge 2,000 m³ in 1 hr. A telescopic tremie tube was installed, and the length of the tube was adjusted so that the sand discharged would not disturb the spread of the sludge as it contacted the seafloor. The sea sand had a average specific gravity of 2.62 and silt content of 0.6 to 1.5 percent. The design thickness was 0.5 m. Results of the field tests showed the average 0.5-m thickness was obtained using a volume equivalent of 0.25 m of overlay placed twice from a height of 10 to 12 m above the bottom. The sand thickness was stable; the impact on the bottom sediment was diminished at this height, and turbidity and resettling were minimized. This conveyor barge method was considered to be an efficient and mobile technique for sand overlaying and is applicable in a wide range of areas.

11 Summary and Recommendations

Summary

This report presents technical guidance for subaqueous dredged material capping. The guidance is summarized as follows:

- a.* Capping is the controlled accurate placement of contaminated material at an open-water disposal site, followed by a covering or cap of clean isolating material. Within the context of capping, the term “contaminated” refers to material that needs isolation from the benthic environment, while the term “clean” refers to material found to be suitable for open-water disposal.
- b.* A capping operation must be treated as an engineered project with carefully considered design, construction, and monitoring to ensure that the design is adequate.
- c.* There is a strong interdependence between all components of the design for a capping project. By following an efficient sequence of activities for design, unnecessary data collection and evaluations can be avoided, and a fully integrated design is obtained.
- d.* The basic criterion for a successful capping operation is simply that the cap thickness required to isolate the contaminated material from the environment can be successfully placed and maintained.
- e.* The contaminated sediment must be characterized from physical, chemical, and biological standpoints. Physical characteristics are of importance in determining the behavior of the material during and following placement at a capping site. Chemical and biological characterization data for the contaminated material to be capped are useful in determining potential water column effects during placement and acceptable exposure times before placement of the cap begins.
- f.* The capping sediment must also be characterized from the physical, chemical, and biological standpoints. Physical characteristics determine the behavior during placement of the cap and long-term

consolidation and stability against erosion. Chemical and biological characterization should determine if the capping sediment is acceptable for unrestricted open-water disposal (i.e., a “clean” sediment).

- g.* The selection of an appropriate site is a critical requirement for any capping operation. The general considerations for selection of any nondispersive open-water site also apply to selection of a site for capping, but a capping site requires special consideration of bathymetry, currents, water depths, bottom-sediment characteristics, and operational requirements. In general, capping sites should be located in relatively low-energy environments with little potential for erosion of the cap.
- h.* A number of different equipment types and placement techniques can be considered for capping operations. Conventional discharge of mechanically dredged material from barges and hydraulically dredged material from hopper dredges or pipelines can be considered if the anticipated bottom spread and water column dispersion are acceptable. If water column dispersion must be reduced or if additional control in placement is required, use of diffusers, tremies, and other equipment needed for submerged discharge can be considered. Controlled discharge and movement of barges and use of spreader plates or boxes with hydraulic pipelines can be considered for spreading a capping layer over a larger area. Compatibility between equipment and placement technique for contaminated and capping material is essential for any capping operation.
- i.* Accurate navigation to the disposal site and precise positioning during material placement are required for capping operations. State-of-the-art equipment and techniques must be employed to ensure accurate placement to the extent deemed necessary. Diligent inspection of operations to ensure compliance with specifications is essential.
- j.* Scheduling of the contaminated-material placement and capping operation must consider both exposure of the contaminated material to the environment and engineering and operational constraints.
- k.* Evaluation of potential water column effects due to placement of contaminated material must be performed. If water column release is unacceptable, control measures must be considered to reduce the potential for water column effects, or other dredging equipment and placement techniques or use of another capping site can be considered.
- l.* The cap must be designed to chemically and biologically isolate the contaminated material from the aquatic environment. The determination of the minimum required cap thickness is dependent on the physical and chemical properties of the contaminated and capping sediments, the potential for bioturbation of the cap by aquatic organisms, and the potential for consolidation and erosion of the cap material.

- m.* The spread and mounding behavior of contaminated material during placement must be evaluated to predict the geometry of the deposit and resulting cap material requirements. The capping material behavior must be similarly evaluated to determine if the design of the cap and volume of capping material available are adequate. The smaller the “footprint” of the contaminated material as placed, the less volume of capping material will be required to achieve a given cap thickness.
- n.* An evaluation of the consolidation and long-term potential for erosion of the mound or deposit must be conducted to ensure that the required cap thickness can be maintained. The design-cap thickness must be adjusted to account for potential erosion and consolidation. The cap can also be armored with coarser material to minimize erosion.
- o.* Monitoring of capped sites is required during and following placement of the contaminated and capping material to ensure that an effective cap has been constructed and to ensure that the cap as constructed is effective in isolating the contaminants and that long-term integrity of the cap is maintained. Design of monitoring programs must be logically developed, prospective in nature, and tiered with each tier having its own thresholds, null hypotheses, sampling design, and management responses based on exceedance of predetermined thresholds.
- p.* Capping of contaminated material in open-water sites began in the late 1970s, and a number of capping operations under a variety of disposal conditions have been accomplished. Field experience with these projects has shown that the capping concept is technically and operationally feasible.
- q.* The cost of capping is generally lower than alternatives involving confined (diked) disposal facilities. The geochemical environment for subaqueous capping favors long-term stability of contaminants as compared with the upland environment where geochemical changes may favor increased mobility of contaminants. Capping is therefore an attractive alternative for disposal of contaminated sediments from both economic and environmental standpoints.

Recommendations

As more designs are completed and additional field experience is gained, the technical guidelines in this report should be refined and expanded. Additional research is also recommended to develop improved tools for capping evaluations. Specific recommendations for further research are summarized as follows:

- a.* More clearly define impacts associated with capping at water depths exceeding 100 ft. PSSDA monitoring has shown material dispersion can be predicted in 300- to 400-ft water depth in Puget Sound.

- b. Refine and verify models for short-term fate of dredged material to allow for predictions within the full range of conditions expected at capping sites.
- c. Refine and verify models that predict subaqueous mound development due to multiple discharges from barges or hopper dredges or long-term discharge from pipelines. Approaches should include both water column and spread behavior of the discharges and the geotechnical considerations associated with mound-slope stability, density flows, and resistance to bearing failure. Such tools will have application for general open-water site management as well as specific application to capping scenarios.
- d. Refine and verify models that predict long-term erosion from dredged material mounds. Additional emphasis should be placed on mounds covered with fine-grained material. Such tools will have application for general open-water site management as well as specific application to capping scenarios.
- e. Refine existing estimates of resuspension of contaminated material during cap placement. This work will assist in determining the costs versus benefits of “sprinkling” cap material versus conventional bottom dumping of cap material.
- f. Develop engineering guidance on acceptable rates and methods of application of capping material over contaminated material of varying density and shear strength. These techniques should consider the geotechnical behavior related to displacement and mixing of contaminated and capping sediments and resistance of the sediments to bearing failure. Extend the investigation to include penetration of dense (e.g., rock) cap material into contaminated material mounds.
- g. Refine existing models for prediction of capped-mound consolidation. This effort will likely require developing or refining instrumentation for in situ geotechnical measurements.
- h. The effect of pore water pressure fluctuations within the mound caused by the surface wave climate should be studied to determine possibility of contaminant release and reduced mound stability.
- i. Develop predictive tools for evaluation of long-term cap integrity, considering chemical migration via consolidation, bioturbation, and diffusion. Both analytical and modeling approaches should be considered. Refinements to sediment-water interface models for this purpose are ongoing under the Disposal Operations Technical Support Program.
- j. Conduct laboratory and field verification studies of long-term cap integrity. Laboratory approaches should include refinement of existing cap-effectiveness tests using columns. Additional laboratory verification of consolidation effects on contaminant migration should be conducted using large geotechnical centrifuges. Field studies should include periodic monitoring and sampling of capped sites to include analysis of core samples.

References

- Ackers, P., and White, R. W. (1973). "Sediment transport: New approach and analysis," *Journal of the Hydraulics Division* 99 (HY11), 2041-60.
- Adamec, S. A., Jr., Johnson, B. H., and Trawle, M. J. (1988). "Numerical modeling of material from Everett, Washington, Naval Port disposed in Puget Sound," Draft Report, U.S. Army Engineer Waterways Experiment Station, Vicksburg Mississippi.
- Allard, R., Farrar, P., Mark, D., Martin, J., Shapiro, B., Lowe, S., and Ko, D. S. (1996). "Creating a 4-D integrated scenario near Camp Pendelton, CA." *Proceedings of the Conference on Coastal Oceanic and Atmospheric Prediction*, Am. Meteorological Soc., Boston, MA.
- Allen, J. R. L. (1970). "The avalanching of granular solids on dune and similar slopes," *Journal of Geology* 78 (3), 326-51.
- American Public Health Association (APHA). (1986). *Standard methods for the examination of water and wastewater*. 15th ed., Washington, DC.
- Ariathurai, R., and Krone, R. B. (1976). "Finite element model for cohesive sediment transport," *Journal of the Hydraulics Division* 102(HY3), 323-38.
- Ariathurai, R., MacArthur, R. C., and Krone, R. B. (1977). "Mathematical model of estuarial sediment transport," Technical Report D-77-12, U.S. Army Engineer Waterways Experiment Station, Vicksburg, MS.
- Averett, D. E., and Palermo, M. R., Otis, M. J., and Rubinoff, P. B. (1989). "New Bedford Harbor Superfund Project, Acushnet River estuary engineering feasibility study of dredging and dredged material disposal alternatives; Report 11, Evaluation of conceptual dredging and disposal alternatives," Technical Report EL-88-15, U.S. Army Engineer Waterways Experiment Station, Vicksburg, MS.

- Bain, C. C., Westerink, J. J., Luettich, R. A., Jr., Scheffner, N. W. (1994). "ADCIRC: An advanced three-dimensional circulation model for shelves, coasts and estuaries; Report 4, Hurricane storm surge modeling using large domains," Technical Report DRP-92-6, U.S. Army Engineer Waterways Experiment Station, Vicksburg, MS.
- _____. (1995). "Influence of domain size and grid structure on the response characteristics of a hurricane storm surge model," Technical Report DRP-95-4, U.S. Army Engineer Waterways Experiment Station, Vicksburg, MS.
- Ballinger, D. C. (1979). "Methods for chemical analysis of water and wastes," EPA 600/4-79-020, U.S. Environmental Protection Agency, Cincinnati, OH.
- Barnard, W. D. (1978). "Prediction and control of dredged material dispersion around dredging and open-water pipeline disposal operations," Technical Report DS-78-13, U.S. Army Engineer Waterways Experiment Station, Vicksburg, MS.
- Bijker, E. W. 1971. "Longshore transport computations," *Journal of the Waterways, Harbors, and Coastal Engineering Division (WW4)*, 687-701.
- Bohlen, W. F., Gee, A., and Germano, J. D. "Sediment capping of subaqueous dredged material disposal mounds: An overview of the New England experience," Report in preparation by Science Applications International Corporation for U.S. Army Engineer Division, New England.
- Bokuniewicz, H. (1989). "Behavior of sand caps on subaqueous dredged material disposal sites," *Oceanic processes in marine pollution, Vol 4, Scientific monitoring strategies for ocean waste disposal*. D. Hood, A. Schoener, and P. K. Parks, ed., Krieger Publishing Co., Malabar, FL.
- Bokuniewicz, H. J., Gerbert, J., Gordon, R. B., Higgins, J. L., Kaminsky, P., Pilbeam, C. C., Reed, M., and Tuttle, C. (1978). "Field study of the mechanics of the placement of dredged material at open-water disposal sites," Technical Report D-78-7, U.S. Army Engineer Waterways Experiment Station, Vicksburg, MS.
- Borgman, L. E., Miller, M. C., Butler, H. L., and Reinhard, R. D. (1992). "Empirical simulation of future hurricane storm histories as a tool in engineering and economic analysis," *Proceedings of Civil Engineering in the Oceans V*, ASCE, New York.

- Borgman, L. E. and Scheffner, N. W. (1991). "The simulation of time sequences of wave height, period, and direction," Technical Report DRP-91-2, U.S. Army Engineer Waterways Experiment Station, Vicksburg, MS.
- Bosworth, W. S. and Thibodeaux, L. J. (1990). "Bioturbation: A facilitator of contaminant transport in bed sediment," *Environmental Progress* 9(4).
- Bowers, G. W., and Goldenblatt, M. K. (1978). "Calibration of a predictive model for instantaneously discharged dredged material," EPA-600/3-78-089, U.S. Environmental Protection Agency, Corvallis, OR.
- Boyer et al. (1994). "Recovery, a mathematical model to predict the temporal response of surface water to contaminated sediments," Technical Report W-94-4, U.S. Army Engineer Waterways Experiment Station, Vicksburg, MS.
- Brandes, H., Silva, A., and Fredette, T. J. (1991). "Settlement of offshore mounds of capped dredged materials," *Maritimes*.
- Brandsma, M. G. and Divoky, D. J. (1976). "Development of models for prediction of short-term fate of dredged material discharged in the estuarine environment," Contract Report D-76-5, U.S. Army Engineer Waterways Experiment Station, Vicksburg, MS.
- Brannon, J. M., et al. (1985). "Effectiveness of capping in isolating contaminated dredged material from biota and the overlying water," Technical Report D-85-10, U.S. Army Engineer Waterways Experiment Station, Vicksburg, MS.
- _____. (1986) "Effectiveness of capping in isolating dutch kill sediment from biota and the overlying water," Miscellaneous Paper D-86-2, U.S. Army Engineer Waterways Experiment Station, Vicksburg, MS.
- Brannon, J., and Poindexter-Rollings, M. E. (1990). "Consolidation and contaminant migration in a capped dredged material deposit," *The Science of the Total Environment* 91, 115-26.
- Bray, R. N., Bates, A. D., and Land, J. M. (1997). *Dredging, a handbook for Engineers*. 2d ed., John Wiley and Sons, New York.
- Brooks, N. H. (1973). "Dispersion in hydrologic and coastal environments," Pacific Northwest Water Quality Laboratory, Northwest Region, U.S. Environment Protection Agency, Corvallis, OR.
- Cargill, K. W. (1982). "Consolidation of soft layers by finite strain theory," Miscellaneous Paper GL-82-3, U.S. Army Engineer Waterways Experiment Station, Vicksburg, MS.

- Cargill, K. W. (1985). "Mathematical model of the consolidation/desiccation process in dredged material," Technical Report D-85-4, U.S. Army Engineer Waterways Experiment Station, Vicksburg, MS.
- Chow, V. T. (1959). *Open channel hydraulics*. McGraw-Hill Book Company, New York.
- Christoffersen, J. B., and Jonsson, I. G. (1985). "Bed friction and dissipation in a combined current and wave motion," *Ocean Engineering* 12(5), 387-423.
- Clausner, J. E., Palermo, M. R., Banks, D., and Palmerton, J. (1996). "Potential application of geosynthetic fabric containers for open water placement of contaminated dredged material," Environmental Effects of Dredging Technical Note EEDP-01-39, U.S. Army Engineer Waterways Experiment Station, Vicksburg, MS.
- Clausner, J. E., Scheffner, N. W., and Allison, M. C. (1995). "Assessment of remaining capacity of the Mud Dump site," Letter Report for New York District, U.S. Army Engineer Waterways Experiment Station, Vicksburg, MS.
- Corson, W. D., Resio, D. T., and Vincent, C. L. (1980). "Wave information study of U.S. coastlines; Report 1, Surface pressure field reconstruction for wave hindcasting purposes," Technical Report HL-80-11, U.S. Army Engineer Waterways Experiment Station, Vicksburg, MS.
- Cox, J. M., Maresca, P., and Jarvela, A. (1995). "Silent inspector user's manual," Instruction Report DRP-95-2, U.S. Army Engineer Waterways Experiment Station, Vicksburg, MS.
- d'Angremond, K., de Jong, A. J., and de Waard, C.-P. (1986). "Dredging of polluted sediment in the 1st Petroleum Harbor, Rotterdam." *Proceedings of the Third United States/The Netherlands Meeting on Dredging and Related Technology*. Prepared for the U.S. Army Corps of Engineers Water Resources Support Center by the U.S. Army Engineer Waterways Experiment Station, Vicksburg, MS.
- Di Toro, D. M., Jeris, J. S., and Clarcia, D. (1985). "Diffusion and partitioning of hexachlorobiphenyl in sediments," *Environ. Sci. Technol.* 19(12), 1169-75.
- Dortch, M. S., Hales, L. Z., Letter, J. V., and McAnally, W. H., Jr. (1990). "Methods of determining the long-term fate of dredged material for aquatic disposal sites," Technical Report D-90-1, U.S. Army Engineer Waterways Experiment Station, Vicksburg, MS.

- Duarte, F., Joseph, J., Satterlee, G. (1995). "Construction of geocontainer and geobag contraction dikes to eliminate dredging at Red Eye Crossing." *Proceedings of Ports '95*, ASCE, New York.
- Earhart, G., Clarke, D., and Shipley, J. (1988). "Beneficial uses of dredged material in shallow coastal waters; Chesapeake Bay demonstration," Information Exchange Bulletin D-88-6, U.S. Army Engineer Waterways Experiment Station, Vicksburg, MS.
- Efron, B. (1982). "The jackknife, the bootstrap and other resampling plans," Society for Industrial and Applied Mathematics, Philadelphia, PA.
- _____. (1990). "More efficient bootstrap computations," *Journal of the American Statistical Association* 85(409), 79-89.
- Elliot, D. O. (1932). "The improvement of the Lower Mississippi River for flood control and navigation," Vol. II, U.S. Army Engineer Waterways Experiment Station, Vicksburg, MS.
- Environmental Laboratory. (1987). "Disposal alternatives for PCB-contaminated sediments from Indiana Harbor, Indiana," Miscellaneous Paper EL-87-9, 2 Vols, U.S. Army Engineer Waterways Experiment Station, Vicksburg, MS.
- Environmental Protection Agency (EPA). (1986). "U.S. Environmental Protection Agency, ocean dumping site designation delegation handbook," Office of Marine and Estuarine Protection, Washington, DC.
- EPA/U.S. Army Corps of Engineers (USACE). (1991). "Evaluation of dredged material proposed for ocean disposal (testing manual)," EPA-503/8-91/001, Office of Water, U.S. Environmental Protection Agency, Washington, DC.
- _____. (1998). "Evaluation of dredged material proposed for discharge in inland and near-coastal waters - Testing manual," EPA-823-B-98-004, U.S. Environmental Protection Agency, Washington, DC.
- Farrar, P. D., Borgman, L. E., Glover, L. B., and Reinhard, R. D., Pope, J., Swain, A., and Ebersole, B. (1994). "Storm impact assessment for beaches at Panama City, Florida," Technical Report CERC-94-11, U.S. Army Engineer Waterways Experiment Station, Vicksburg, MS.
- Francingues, N. R., Palermo, M. R., Lee, C. R., and Peddicord, R. K. (1985). "Management strategy for disposal of dredged material: Contaminant testing and controls," Miscellaneous Paper D-85-1, U.S. Army Engineer Waterways Experiment Station, Vicksburg, MS.

- Fredette, T. J. (1994). "Disposal site capping management: New Haven Harbor." *Proceedings of Dredging '94*, ASCE, New York.
- Fredette, T. J., Anderson, G., Payne, B. S. and Lunz, J. D. (1986). "Biological monitoring of open-water dredged material disposal sites." *IEEE Oceans '86 Conference Proceedings, Washington, DC*.
- Fredette, T. J., Bohlen, W. F., Rhoads, D. C., and Morton, R. W. (1988). "Erosion and resuspension effects of Hurricane Gloria at Long Island Sound dredged material disposal site." *U.S. Army Corps of Engineers Seventh Annual Water Quality Seminar Proceedings, Charleston, SC*.
- _____. (1989). "Erosion and resuspension effects of Hurricane Gloria at Long Island Sound dredged material disposal sites," Environmental Effects of Dredging Information Exchange Bulletin, Vol D-89-2, U.S. Army Engineer Waterways Experiment Station, Vicksburg, MS.
- Fredette, T. J., Germano, J. D., Carey, D. A., Murray, P. M., and Kullberg, P. G. (1992). "Chemical stability of capped dredged material disposal mounds in Long Island Sound, USA," *Chemistry and Ecology* 7, 173-94.
- Fredette, T. J., Germano, J. D., Kullberg, P. G., Carey, D. A., and Murray, P. "Chemical stability of capped dredged material disposal mounds in Long Island Sound, USA." *1st International Ocean Pollution Symposium, Mayaguez, Puerto Rico. Chemistry and Ecology*. In preparation.
- Fredette, T. J., Nelson, D. A., Clausner, J. E., and Anders, F. J. (1990a). "Guidelines for physical and biological monitoring of aquatic dredged material disposal sites," Technical Report D-90-12, U.S. Army Engineer Waterways Experiment Station, Vicksburg, MS.
- Fredette, T. J., Nelson, D. A., Miller-Way, T., Adair, J. A., Sotler, V. A., Clausner, J. E., Hands, E. B., and Anders, F. J. (1990b). "Selected tools and techniques for physical and biological monitoring of aquatic dredged material disposal sites," Technical Report D-90-11, U.S. Army Engineer Waterways Experiment Station, Vicksburg, MS.
- Freeland, G. L., et al. (1983). "Sediment cap stability study of New York dredged material dumpsite," Support Agreement No. NYD 80-124CC, by Atlantic Oceanographic and Meteorological Laboratory, National Oceanic and Atmospheric Administration, Miami, FL, for U.S. Army Engineer District, New York.
- Gibson, R. E., England, G. L., Hussey, M. J. L. (1967). "The theory of one-dimensional consolidation of saturated clays; I, Finite nonlinear consolidation of thin homogeneous layers," *Geotechnique* 17(3), 261-73.
- Gibson, R. E., Schiffman, R. L., and Cargill, K. W. (1981). "The theory of one-dimensional consolidation of saturated clays, II, fine non-linear

- consolidation of thick homogeneous layers,” *Canadian Geotechnical Journal* 18, 289-93.
- Gordan, R. (1974). “Dispersion of dredged spoil dumped in near-shore waters,” *Estuarine and Coastal Marine Science* 2, 349-58.
- Greges, M. (1994). “Ocean disposal with capping of dioxin contaminated sediment: New York case history #1.” *Proceedings of Dredging ‘94*, American Society of Civil Engineers, New York, 1278-84.
- Gunnison, D., et al. (1987a). “Appendix F: Evaluation of the effectiveness of capping in isolating contaminated Indiana Harbor dredged material from biota and the overlying water,” Miscellaneous Paper EL-87-9, Vol II, U.S. Army Engineer Waterways Experiment Station, Vicksburg, MS.
- _____. (1987b). “Development of a simplified column test for evaluation of thickness of capping material required to isolate contaminated dredged material,” Miscellaneous Paper D-87-2, U.S. Army Engineer Waterways Experiment Station, Vicksburg, MS.
- Hales. (1995). “Accomplishments of the Corps of Engineers Dredging Research Program,” *Journal of Coastal Research* 11(1), 68-88.
- Hands, E. B., and Allison, M. C. (1991). “Mound migration in deeper water and methods of categorizing active and stable berms.” *Proceedings of Coastal Sediments ‘91*, ASCE, 1985-99.
- Hayes, D. F., McLellan, T. N., and Truitt, C. L. (1988). “Demonstrations of innovative and conventional dredging equipment at Calumet Harbor, Illinois,” Miscellaneous Paper EL-88-1, U.S. Army Engineer Waterways Experiment Station, Vicksburg, MS.
- Headland, R. E., Lesnik, J. R., McNeilan, T. W., and Hooper, J. R. (1995). “Feasibility study of sediment restoration alternatives for the southern California natural resource damage assessment; Appendix G: Hydrodynamics and geotechnical assessment of the in-situ capping alternative,” Moffatt and Nichols Engineers, Baltimore, MD.
- Headquarters, U.S. Army Corps of Engineers (HQUSACE). (1983). “Dredging and dredged material disposal,” Engineer Manual 1110-2-5025, 25 March 1983, Washington DC.
- _____. (1984). “Shore Protection Manual,” Washington, DC.
- Hench, J. L., Luettich, R. A., Jr., Westerink, J. J., and Scheffner, N. W. (1994). “ADCIRC: An advanced three-dimensional circulation model for shelves, coasts and estuaries; Report 6, Development of a tidal constituent database for the eastern North Pacific,” Technical Report

DRP-92-6, U.S. Army Engineer Waterways Experiment Station,
Vicksburg, MS.

Herbich, J. B. (1992). *Handbook of dredging engineering*. McGraw-Hill,
Inc., New York.

Ho, F. P., Su, J. C., Hanevich, K. L., Smith, R. J., and Richards, F. P.
(1987). "Hurricane climatology for the Atlantic and Gulf Coasts,"
Technical Report NWS 38, National Weather Service, NOAA, Silver
Spring, MD.

Hubertz, J. M., Brooks, R. M., Brandon, W. A., and Tracy, B. A., (1993).
"Hindcast wave information for the U.S. Atlantic Coast," WIS Report
30, Coastal Engineering Research Center, U.S. Army Engineer Water-
ways Experiment Station, Vicksburg, MS.

Ippen, A. T., ed. (1966). *Estuary and coastline hydrodynamics*. McGraw-
Hill Book Co., Inc., New York.

Jarvinen, B. R., Neumann, C. J., and Davis, M. A. S. (1988). "A tropical
cyclone data tape for the North Atlantic Basin, 1886-1983: Contents,
limitations, and uses," NOAA Technical Memorandum NWS NHC 22.

JBF Scientific Corporation. (1975). "Dredging technology study, San Fran-
cisco Bay and Estuary," U.S. Army Engineer District, San Francisco,
CA.

Jensen, R. E., Hubertz, J. M., Thompson, E. F., Reinhard, R. D., Bishop,
B. J., Brandon, W. A., Payne, J. B., Brooks, R. M., and McAneny, D. S.
(1992). "Southern California hindcast wave information," WIS
Report 20, U.S. Army Engineer Waterways Experiment Station, Vicks-
burg, MS.

Johanson, E. E., Bowen, S. P., and Henry, G. (1976). "State-of-the-art sur-
vey and evaluation of open-water dredged material placement method-
ology," Contract Report D-76-3, prepared by JBF Scientific Corporation
for U.S. Army Engineer Waterways Experiment Station, Vicksburg, MS.

Johnson, B. H. (1978). "Application of the instantaneous dump dredged
material disposal model to the disposal of Stamford and New Haven
Harbor material from a scow in the Long Island Sound," Internal
Working Document prepared for New England Division, U.S. Army
Engineer Waterways Experiment Station, Vicksburg, MS.

_____. (1979). "Application of the instantaneous dump dredged
material disposal model to the disposal of San Diego Harbor material at
the 45 and 100 fathom disposal sites," Internal Working Document,
U.S. Army Engineer Waterways Experiment Station, Vicksburg, MS.

- _____. (1990). "User's guide for models of dredged material disposal in open water," Technical Report D-90-5, U.S. Army Engineer Waterways Experiment Station, Vicksburg, MS.
- Johnson, B. H. (1992). "Numerical disposal modeling." Technical Note DRP-1-02, U.S. Army Engineer Waterways Experiment Station, Vicksburg, MS.
- Johnson, B. H., and Fong, M. T. (1995). "Development and verification of numerical models for predicting the initial fate of dredged material disposed in open water; Report 2, Theoretical developments and verification results," Technical Report DRP-93-1, U.S. Army Engineer Waterways Experiment Station, Vicksburg, MS.
- Johnson, B. H., and Holliday, B. W. (1977). "Numerical model results of dredged material disposal at ten proposed ocean disposal sites in the Hawaiian Islands," Miscellaneous Paper H-77-6, U.S. Army Engineer Waterways Experiment Station, Vicksburg, MS.
- _____. (1978). "Evaluation and calibration of the Tetra Tech dredged material disposal models based on field data," Technical Report D-78-47, U.S. Army Engineer Waterways Experiment Station, Vicksburg, MS.
- Johnson, B. H., McComas, D. N., McVan, D. C., and Trawle, M. J. (1993). "Development and verification of numerical models for predicting the initial fate of dredged material disposed in open water; Report 1, Physical model tests of dredged material disposal from a split-hull barge and a multiple bin vessel," Technical Report DRP-93-1, U.S. Army Engineer Waterways Experiment Station, Vicksburg, MS.
- Jonsson, I. G. (1966). "Wave boundary layers and friction factors." *Proc., Coast. Engrg. Conf., 10th, Tokyo, Japan.*
- Kikegawa, K. (1983). "Sand overlying for bottom sediment improvement by sand spreader." *Management of bottom sediments containing toxic substances: Proceedings of the 7th U.S./Japan Experts Meeting.* Prepared for the U.S. Army Corps of Engineers Water Resources Support Center by the U.S. Army Engineer Waterways Experiment Station, Vicksburg, MS, 79-103.
- Kleinboesam, W. C. H., and van der Weijde, R. W. (1983). "A special way of dredging and disposing of heavily polluted silt in Rotterdam," World Dredging Congress 1983, Paper M2, Singapore, 509-25.
- Koh, R. C. Y., and Chang, Y. C. (1973). "Mathematical model for barged ocean disposal of waste," Environmental Protection Technology Series EPA 660/2-73-029, U.S. Environmental Protection Agency, Washington, DC.

- Kraus, N. C., and Larson, M. (1988). "Beach profile change measured in the tank for large waves, 1956-1957 and 1962," Technical Report CERC-86-6, U.S. Army Engineer Waterways Experiment Station, Vicksburg, MS.
- Larson, M., and Kraus, N. C. (1989). "SBEACH: Numerical model for simulating storm induced beach change; Report 1, Theory and model foundation," Technical Report CERC-89-9, U.S. Army Engineer Waterways Experiment Station, Vicksburg, MS.
- Lavelle, J. W., Mofjeld, H. O., and Baker, E. T. (1984). "An in situ erosion rate for a fine-grained marine sediment," *J. Geophys. Res.* 89(C4), 6543-552.
- Lermans, A. (1979). *Geochemical processes water and sediment environments*. John Wiley and Sons, New York.
- Lillicrop, W. J., Garcia, A. W., Howell, G. L., and Grogg, W. E. (1991). "Automated real-time tidal elevation system for offshore dredging operations." Chapter 42. *Tidal hydrodynamics*. B. B. Parker, ed., John Wiley and Sons, Inc., New York, 829-37.
- Ling, H. I., Leshchinsky, D., Gilbert, P. A., and Palermo, M. R. (1996). "In-situ capping of contaminated submarine sediments: Geotechnical considerations." *Environmental geotechnics*. A. A. Masashi Kamon, ed., Balkem, Rotterdam, The Netherlands, 575-580.
- Luettich, R. A., Jr., Westerink, J. J., and Scheffner, N. W. (1992). "ADCIRC: An advanced three-dimensional circulation model for shelves, coasts, and estuaries; Report 1, Theory and methodology of ADCIRC-2DDI and ADCIRC-3DL," Technical Report DRP-92-6, U.S. Army Engineer Waterways Experiment Station, Vicksburg, MS.
- Mansky, J. M. (1984). "Underwater capping of contaminated dredged material in New York Bight Apex," Environment Effects of Dredging, Information Exchange Bulletin, Vol D-84-4, U.S. Army Engineer Waterways Experiment Station, Vicksburg, MS.
- Marine Board, National Research Council. (1990). *Managing troubled waters - The role of marine environmental monitoring*. National Academy Press, Washington, DC.
- Mark, D. J., and Scheffner, N. W. (1993). "Validation of a continental-scale storm surge model for the cost of Delaware." *3rd International Conference on Estuarine and Coastal Modeling, Chicago, IL*.
- Matisoff, G. "Mathematical models of bioturbation." *Animal-sediment relations*. P. L. McCall and M. J. Tevesz, ed., Plenum Press, New York, 289-331.

- May, B., Pabst, D., and McDowell, S. L. (1994). "Dioxin capping management and monitoring program: Design and implementation." *Proceedings of Dredging '94*. American Society of Civil Engineers, New York, 1027-36.
- McAneny, D. "The coastal engineering data retrieval system (CEDRS)," Miscellaneous Paper in preparation, U.S. Army Engineer Waterways Experiment Station, Vicksburg, MS.
- McDowell, S. (1993). "Comparison of baseline bathymetric surveys: New York Mud Dump site," Report by Science Applications International Corporation, submitted to USAE District, New York, New York.
- McDowell, S., May, B., and Pabst, D. (1994). "The December 1992 storm at the New York Mud Dump site." *Proceedings of Dredging '94*, ASCE, New York.
- McFarland, V. A. "A bioaccumulation study testing the effectiveness of varying cap apron thicknesses for isolation of dioxin," Report in preparation, U.S. Army Engineer Waterways Experiment Station, Vicksburg, MS.
- McLellan, T. N., and Truitt, C. L. (1986). "Demonstration of a submerged diffuser for dredged material disposal." *Proceedings of the Conference Oceans '86, Washington, DC*.
- McNeil, J., Taylor, C., and Lick, W. "Measurements of the erosion of undisturbed bottom sediments with depth," accepted for publication to *Journal of Hydraulic Engineering*.
- Mehta, A. J., Hayter, E. J., Parker, W. R., Krone, R. B., and Teeter, A. M. (1989). "Cohesive sediment transport - I: Process description," *Journal of Hydraulic Engineering*, ASCE, 115(3), 1076-93.
- Mesa, C. L. (1995). "Containerization of contaminated dredge sediments - the Marina Del Rey experience." *Proceedings of the 25th Texas A&M Annual Dredging Seminar, TAMU Center for Dredging Studies, College Station, TX*.
- Moritz, H. R. (1994). "User's guide for the multiple dump fate model, final report," Contract Report DACW39-94-M-1304, Prepared for the U.S. Army Engineer Waterways Experiment Station, Vicksburg, MS.
- _____. (1997). "Management of ocean dredged material disposal sites at the mouth of the Columbia River." *Proceedings of the Western Dredging Association Eighteenth Technical Conference and Thirtieth Annual Texas A&M Dredging Seminar*. Center for Dredging Studies, Texas A&M University, College Station, TX, 119-139.

- Moritz, H. R., and Randall, R. E. (1992). "User guide for the open water disposal area management simulation," Final Report by Texas A&M Research Foundation to U.S. Army Engineer Waterways Experiment Station, Contract Number DACW39-90-K-0015, Vicksburg, MS.
- Moritz, H. R., and Randall, R. E. 1995. "Simulating dredged material placement at open water disposal sites," *Journal of Waterway, Port, Coastal, and Ocean Engineering*, ASCE, 121(1).
- Morton, R. W. (1980a). "Capping procedures as an alternative technique to isolate contaminated dredged material in the marine environment," Report to USACE, New England Division, Newport, RI, Science Applications, Inc.
- _____. (1980b). "The management and monitoring of dredge spoil disposal and capping procedures in central Long Island Sound." *Second annual ocean dumping symposium, Woods Hole, MA*. DAMOS Contribution No. 8, U.S. Army Corps of Engineers, New England, Waltham, MA.
- _____. (1983a). "Precision bathymetric study of dredged material capping experiment in Long Island Sound." *Wastes in the ocean, Volume II. Dredged material disposal*. D. R. Kester, I. W. Duedall, B. H. Ketchum, and P. K. Parks, ed., John Wiley and Sons, Inc., New York, 99-121.
- _____. (1983b). "Capping procedures as an alternative technique to isolate contaminated dredged material in the marine environment." *Proceedings of the 7th US/Japan Experts Meeting*. U.S. Army Engineer Waterways Experiment Station, Vicksburg, MS, 108-133.
- _____. (1987). "Recent studies concerning the capping contaminated dredged material." *Proceedings of the United States/Japan Experts Meeting on management of bottom sediments containing toxic substances, November 3-6, 1987, Baltimore, MD*.
- _____. (1989). "Monitoring the effectiveness of capping for isolating contaminated sediments." *Symposium/workshop on contaminated marine sediments, Tampa, FL*. Nat. Acad. Press, Washington, DC, 262-279.
- Morton, R. W., Parker, J. H., and Richmond, W. H., ed. (1984). "Disposal area monitoring system: Summary of program results 1981-1984," DAMOS Contribution #46, Science Applications International Corporation of U.S. Army Engineer Division, New England, Waltham, MA.
- Mudrock, A., and MacKnight, S. D. (1991). *Handbook of techniques for aquatic sediment sampling*. CRC Press, Boca Raton, FL.

- Myers, A. C. (1979). "Summer and winter burrows of a Mantis shrimp, *Squilla empusa*, in Narragansett Bay, Rhode Island (USA)," *Estuarine Coastal Marine Science* 8, 87-98.
- Myers, T. E., Averett, D. E., Olin, T. J., Palermo, M. R., Reible, D. D., Martin, J. L., and McCutcheon, S. C. (1996). "Estimating contaminant losses from components of remediation alternatives for contaminated sediments," EPA 905-R96-001, March 1996, Assessment and Remediation of Contaminated Sediments (ARCS) Program, U.S. Environmental Protection Agency, Great Lakes National Program Office, Chicago, IL.
- Myers, V. A. (1975). "Storm tide frequencies on the South Carolina coast," Technical Report NWS-16, National Weather Service, NOAA, Silver Spring, MD.
- Neal, R. W., Henry, G., and Greene, S. H. (1978). "Evaluation of the submerged discharge of dredged material slurry during pipeline dredged operations," Technical Report D-78-44, by JBF Scientific Corp. for U.S. Army Engineer Waterways Experiment Station, Vicksburg, MS.
- Nelson, E. E., Vanderheiden, A. L., and Schuldt, D. A. (1994). "Eagle Harbor Superfund Project." *Proceedings of Dredging '94*, American Society of Civil Engineers, New York, 1122-1131.
- New York District. (1994). "New York Harbor dredged material management plan: Draft Phase I assessment."
- Nichols, M. N., Thompson, G. S., and Faas, R. W. (1978). "A field study of fluid mud dredged material: Its physical nature and dispersal," Technical Report D-78-40, U.S. Army Engineer Waterways Experiment Station, Vicksburg, MS.
- O'Connor, J. M., and O'Connor, S. G. (1983). "Evaluation of the 1980 capping operations at the experimental Mud Dump site, New York Bight Apex," Technical Report D-83-3, U.S. Army Engineer Waterways Experiment Station, Vicksburg, MS.
- Palermo, M. R. (1989). "Capping contaminated dredged material in deep water." *Proceedings of the Specialty Conference Ports 89*, American Society of Civil Engineers, Boston, MA.
- _____. (1991a). "Design requirements for capping," Dredging Research Technical Note DRP-5-03, U.S. Army Engineer Waterways Experiment Station, Vicksburg, MS.
- _____. (1991b). "Site selection considerations for capping," Technical Note DRP-5-04, U.S. Army Engineer Waterways Experiment Station, Vicksburg, MS.

- _____. (1991c). "Equipment and placement techniques for capping," Technical Note DRP-5-05, U.S. Army Engineer Waterways Experiment Station, Vicksburg, MS.
- Palermo, M. R. (1994). "Placement techniques for capping contaminated sediments." *Proceedings of Dredging '94, The Second International Conference and Exhibition on Dredging and Dredged Material Placement*. American Society of Civil Engineers, Lake Buena Vista, FL.
- _____. "Diffuser for submerged discharge of dredge material," Environmental Effects of Dredging Programs Technical Note in preparation, U.S. Army Engineer Waterways Experiment Station, Vicksburg, MS.
- Palermo, M. R., et al. (1989). "Evaluation of dredged material disposal alternatives for U.S. Navy Homeport at Everett, Washington," Technical Report EL-89-1, U.S. Army Engineer Waterways Experiment Station, Vicksburg, MS.
- Palermo, M. R., Fredette, T. J., and Randall, R. E. (1992). "Monitoring considerations for capping," Dredging Research Technical Notes, DRP-5-07, U.S. Army Engineer Waterways Experiment Station, Vicksburg, MS.
- Palermo, M. R., Maynard, S., Miller, J., and Reible, D. D. (1996). "Guidance for in-situ subaqueous capping of contaminated sediments," Environmental Protection Agency, EPA 905-B96-004, Great Lakes National Program Office, Chicago, IL.
- Parker, J. H., and Valente, R. (1988). "Long-term sand cap stability: New York dredged material disposal site," Contract Report CERC-88-2, performed by Science Applications International Corporation under contract to U.S. Army Engineer Waterways Experiment Station, Vicksburg, MS.
- Parry, R. (1994). "Constructing beneficial use dredged material projects." *Proceedings of Dredging '94*, ASCE, New York, 547-554.
- Parthenaides, E. (1965). "Erosion and deposition of cohesive soils," *Journal of Hydraulics*, Div. Am Soc. Civ. Eng., 91(HY1), 105-138,
- Pearson, T. H. (1987). "Benthic ecology in an accumulating sludge-disposal site." *Oceanic processes and marine pollution; Vol. 1, Biological processes and wastes in the ocean*. J. M. Capuzzo and D. R. Kester, ed., Krieger Publishing, Malabar, FL, 195-200.
- Pequegnat, W. E., Gallaway, B. J., and Wright, T. D. (1990). "Revised procedural guide for designation surveys of ocean dredged material disposal sites," Technical Report D-90-8, U.S. Army Engineer Waterways Experiment Station, Vicksburg, MS.

- Poindexter, M. E. (1989). "Monitoring dredged material consolidation and settlement at aquatic disposal sites," Environmental Effects of Dredging Program Technical Note EEDP-01-5, U.S. Army Engineer Waterways Experiment Station, Vicksburg, MS.
- Poindexter-Rollings, M. E. (1990). "Methodology for analysis of sub-aqueous sediment mounds," Technical Report D-90-2, U.S. Army Engineer Waterways Experiment Station, Vicksburg, MS.
- Prater, M. D., Hardy, T. A., Butler, H. L., and Borgman, L. E. (1985). "Estimating error of coastal stage frequency curves." *Proceedings of the 19th International Conference on Coastal Engineering*. ASCE, New York.
- Randall, R. E. (1986). "Synthesis procedures for evaluating site capacity for open-water disposal of dredged material," Miscellaneous Paper in review, U.S. Army Engineer Waterways Experiment Station, Vicksburg, MS.
- Randall, R. E., Clausner, J. E., and Johnson, B. H. (1994). "Modeling cap placement at New York Mud Dump site." *Proceedings of Dredging '94*, American Society of Civil Engineers, New York, 1295-1304.
- Resio, D. T., and Hands, E. B. (1994). "Understanding and interpreting seabed drifter (SBD) data," Technical Report DRP-94-1, U.S. Army Engineer Waterways Experiment Station, Vicksburg, MS.
- Richardson, T. W., ed. (1993). "Summary of results assessments for proposed capping project New York Bight mud dump dredged material disposal site," Letter report to New York District by the Coastal Engineering Research Center, U.S. Army Engineer Waterways Experiment Station, Vicksburg, MS.
- Rhoads, D. C., and Boyer, L. F. (1982). "The effects of marine benthos on physical properties of sediments: A successional perspective." *Animal-sediment relations*. P. L. McCall and M. Tevesz, ed., Plenum Press, New York.
- Rhoads, D. C., and Germano, J. D. (1982). "Characterization of organism-sediment relations using sediment profile imaging: An efficient method of remote monitoring of the sea floor (REMOTS©), *Marine Ecology Progress Series* 8, 115-128.
- Roberts, P. J. W., Ferrier, A., and Johnson, B. H. (1994). "New techniques for experimental studies of dredged material dispersion." *Proceedings of Dredging '94*, American Society of Civil Engineers, New York, 1192-1200.

- Rollings, M. P. (1994). "Geotechnical considerations in dredged material management." *Proceedings, First International Congress on Environmental Geotechnics, International Society for Soil Mechanics and Foundation Engineering and Canadian Geotechnical Society, Edmonton, Alberta.*
- Rollings, M. P. (1997). "Dredged material consolidation models: Evaluation and comparison of predictive capabilities," DOER Technical Note in preparation, U.S. Army Engineer Waterways Experiment Station, Vicksburg, MS.
- Sanderson, W. H., and McKnight, A. L. (1986). "Survey of equipment and construction techniques for capping dredged material," Miscellaneous Paper D-86-6, U.S. Army Engineer Waterways Experiment Station, Vicksburg, MS.
- Scheffner, N. W. (1989). "Disposal site evaluation for the New York Bight," Coastal Engineering Research Center, U.S. Army Engineer Waterways Experiment Station, Vicksburg, MS.
- _____. (1991a). "A generalized approach to site classification - Dispersive or non-dispersive," Dredging Research Information Exchange Bulletin, Vol. DRP-91-1, U.S. Army Engineer Waterways Experiment Station, Vicksburg, MS.
- _____. (1991b). "A systematic analysis of disposal site stability." *Proceedings of Coastal Sediments '91*. ASCE, 2012-26.
- _____. (1992). "Dispersion analysis of Humboldt Bay, California, interim offshore disposal site," Miscellaneous Paper DRP-92-1, U.S. Army Engineer Waterways Experiment Station, Vicksburg, MS.
- _____. (1994). "Tidal constituent data base - East Coast, Gulf of Mexico, and Caribbean Sea," DRP Technical Note DRP-1-13, U.S. Army Engineer Waterways Experiment Station, Vicksburg, MS.
- Scheffner, N. W., Borgman, L. E., and Mark, D. J. (1993). "Applications of large domain hydrodynamic models to generate frequency of occurrence relationships." *Proceedings 3rd International Conference on Estuarine and Coastal Modeling, Chicago, IL.*
- Scheffner, N. W., and Borgman, L. E. (1992). "A stochastic time series representation of wave data," *Journal of Waterways, Ports, Coastal, and Ocean Engineering* 118(4).
- Scheffner, N. W., Mark, D. J., Blain, C. A., Westerink, J. J., and Luettich, R. A., Jr. (1994). "ADCIRC: An advanced three-dimensional circulation model for shelves, coasts and estuaries; Report 5, A tropical storm database for the east and Gulf of Mexico Coasts of the United States,"

Technical Report DRP-92-6, U.S. Army Engineer Waterways Experiment Station, Vicksburg, MS.

- Scheffner, N. W., and Tallent, J. R. (1994). "Dispersion analysis of the Charleston, South Carolina, ocean dredged material disposal site," Miscellaneous Paper DRP-94-1, U.S. Army Engineer Waterways Experiment Station, Vicksburg, MS.
- Scheffner, N. W., Thevenot, M. M., Tallent, J. R., and Mason, J. M. (1995). "LTFATE: A model to investigate the long-term fate and stability of dredged material disposal sites; User's guide," Instruction Report DRP-95-1, U.S. Army Engineer Waterways Experiment Station, Vicksburg, MS.
- Schroeder, P. R., and Palermo, M. R. (1990). "The automated dredging and disposal alternatives management system (ADDAMS)," Technical Note EEDP-06-12, U.S. Army Engineer Waterways Experiment Station, Vicksburg, MS.
- Science Applications International Corporation (SAIC). (1990). "Capping survey, New London disposal site, Feb. 3, 1989," DAMOS Contribution Number 71, U.S. Army Corps of Engineers, New England Division.
- _____. (1995a). "Sediment capping of subaqueous dredged material disposal mounds: An overview of the New England experience, 1979-1993," DAMOS Contribution #95. SAIC Report No. SAIC-90/7573 prepared for the U.S. Army Engineer Division, New England, Waltham, MA.
- _____. (1995b). "Monitoring cruise at the central Long Island Sound disposal site, July 1990," DAMOS Contribution #94, U.S. Army Engineer Division, New England, Waltham, MA.
- _____. (1996). "Monitoring cruise at the Portland Disposal Site, July 1992," DAMOS Contribution Number 108, U.S. Army Corps of Engineers, New England Division.
- Scott et al. (1987). "Impact of open-water disposal of Black Rock Harbor dredged material on benthic recolonization at the FVP site," Technical Report D-87-4, U.S. Army Engineer Waterways Experiment Station, Vicksburg, MS.
- Sea Surveyor, Inc. (1994). "Queens Gate dredging geotechnical and chemical investigation," Report prepared for the Port of Long Beach, Benicia, CA.
- Shields, F. D., and Montgomery, R. L. (1984). "Fundamentals of capping contaminated dredged material." *Proceedings of the Conference Dredging '84*, American Society of Civil Engineers, 1, 446-460.

- Silva, A. J., Brandes, H. G. Uchytel, C. J., Fredette, T. J., and Carey, D. (1994). "Geotechnical analysis of capped dredged material mounds." *Proceedings of Dredging '94*, ASCE, New York, 410-419.
- Stark, T. D. (1991). "Program documentation user's guide: PSDDF89, primary consolidation and desiccation of dredged fill," Instruction Report D-91-1, U.S. Army Engineer Waterways Experiment Station, Vicksburg, MS.
- Stark, T. D. "Program documentation and user's guide: PSDDF, secondary consolidation and desiccation of dredged fill," Report in preparation, U.S. Army Engineer Waterways Experiment Station, Vicksburg, MS.
- Sturgis, T., and Gunnison, D. (1988). "A procedure for determining cap thickness for capping subaqueous dredged material deposits," Technical Note EEDP-01-09, U.S. Army Engineer Waterways Experiment Station, Vicksburg, MS.
- Sumeri, A. (1984). "Capped in-water disposal of contaminated dredged material." *Proceedings of the Conference Dredging '84*, American Society of Civil Engineers, 2, 644-653.
- _____. (1989). "Confined aquatic disposal and capping of contaminated bottom sediments in Puget Sound." *Proceedings of the WOD-CON XII, Dredging: Technology, Environmental, Mining, World Dredging Congress, Orlando, FL, 2-5 May 1989*.
- _____. (1995). "Dredged material is not a spoil: A status on the use of dredged material in Puget Sound to isolate contaminated sediments." *Proceedings of the 14th World Dredging Congress, World Organization of Dredging Associations, Amsterdam, The Netherlands*.
- Sumeri, A., Fredette, T. J., Kullberg, P. G., Germano, J. D., Carey, D. A. (1991). "Sediment chemistry profiles of capped in-situ dredged sediment deposits: Results from three U.S. Army Corps of Engineers offices." *WEDA XII Western Dredging Association and Twenty-fourth Annual Dredging Seminar*.
- Sumeri, A., Fredette, T. J., Kullberg, P. G., Germano, J. D., Carey, D. A., and Pechko, P. (1994). "Sediment chemistry profiles of capped dredged material deposits taken 3 to 11 years after capping," Dredging Research Technical Note DRP-5-09, U.S. Army Engineer Waterways Experiment Station, Vicksburg, MS.
- Sustar, J. F., and Ecker, R. M. (1972). "Monitoring dredge disposal on San Francisco Bay," OTC Paper #1660, Offshore Technology Conference, May 1972, II405-II412.

- Suszowski, D. J. (1983). "Studies on capping of contaminated dredged material by the New York District, Corps of Engineers." *Management of Bottom Sediments Containing Toxic Substances: Proceedings of the 7th US/Japan Experts Meeting*. Prepared for the U.S. Army Corps of Engineers Water Resources Support Center by the U.S. Army Engineer Waterways Experiment Station, Vicksburg, MS, 134-145.
- Swart, D. H. (1976). "Predictive equations regarding coastal transports." *Proceedings of the 15th Coastal Engineering Conference*. ASCE, 1113-32.
- Tavolaro, J. F. (1984). "A sediment budget study of clamshell dredging and ocean disposal activities in the New York Bight," *Environmental Geology and Water Science* 6(3), 133-140.
- Teeter, A. M. (1988). "New Bedford Harbor Superfund project, Acushnet River estuary engineering feasibility study of dredging and dredged material disposal alternatives; Report 2, Sediment and contaminant hydraulic transport investigations," Technical Report EL-88-15, Report 2, U.S. Army Engineer Waterways Experiment Station, Vicksburg, MS.
- Teeter, A. M., and Pankow, W. (1989). "Schematic numerical modeling of harbor deepening effects on sedimentation, Charleston, SC," Miscellaneous Paper HL-89-7, U.S. Army Engineer Waterways Experiment Station, Vicksburg, MS.
- Thoma et al. (1993). "Efficiency of capping contaminated sediments in situ. 2. Mathematics of diffusion - absorption in the capping layer," *Environmental Science and Technology* 27(12).
- Togashi, H. (1983). "Sand overlaying for sea bottom sediment improvement by conveyor barge." *Management of bottom sediments containing toxic substances: Proceedings of the 7th US/Japan Experts meeting*. Prepared for the U.S. Army Corps of Engineers Waters Resources Support Center by the U.S. Army Engineer Waterways Experiment Station, Vicksburg, MS, 59-78.
- Trawle, M. J., and Johnson, B. H. (1986). "Alcatraz disposal site investigation," Miscellaneous Paper HL-86-1, U.S. Army Engineer Waterways Experiment Station, Vicksburg, MS.
- Truitt, C. L. (1986a). "Fate of dredged material during open water disposal," *Environmental Effects of Dredging Programs Technical Note EEDP-01-2*, U.S. Army Engineer Waterways Experiment Station, Vicksburg, MS.
- _____. (1986b). "The Duwamish Waterway capping demonstration project: Engineering analysis and results of physical monitoring," Tech-

nical Report D-86-2, U.S. Army Engineer Waterways Experiment Station, Vicksburg, MS.

Truitt, C. L. (1987a). "Engineering considerations for capping subaqueous dredged material deposits—Background and preliminary planning," Technical Note EEDP-01-3, U.S. Army Engineer Waterways Experiment Station, Vicksburg, MS.

_____. (1987b). "Engineering considerations for capping subaqueous dredged material deposits—Design concepts and placement techniques," Environmental Effects of Dredging Technical Note EEDP-01-4, U.S. Army Engineer Waterways Experiment Station, Vicksburg, MS.

Truitt, C. L., Clausner, J. E., and McLellan, T. N. (1989). "Considerations for capping subaqueous dredged material deposits," *Journal of Waterway, Port, Coastal, and Ocean Engineering* 115(6).

U.S. Army Corps of Engineers (USACE). 1970. "Laboratory soils testing," Engineer Manual 1110-2-1906, Washington, DC.

_____. (1987). "Confined disposal of dredged material," Engineer Manual 1110-2-5027, Washington, DC.

_____. (1990). "New Bedford Harbor Superfund pilot study, evaluation of dredging and dredged material disposal," U.S. Army Engineer Division, New England, Waltham, MA.

_____. (1991). "Hydrographic surveying," Engineer Manual 1110-2-1003, Washington, DC.

U.S. Army Corps of Engineers/Environmental Protection Agency (USACE/EPA). (1984). "General approach to designation studies of ocean dredged material disposal sites," U.S. Army Engineer Water Resources Support Center, Fort Belvoir, VA.

_____. (1992). "Evaluating environmental effects of dredged material management alternatives - A technical framework," EPA842-B-92-008, Environmental Protection Agency, Office of Marine and Estuarine Protection, Washington, DC.

U.S. Department of Transportation. (1984). "Code of Federal regulations," Office of the Federal Register, National Archives and Records Services, General Services Administration, Washington, DC.

Van De Graff, J., and Van Overeem, J. (1979). "Evaluation of sediment transport formulae in coastal engineering practice," *Coast. Engrg.*, Amsterdam, 3, 1-32.

- Van Rijn, L. C. (1989). "Handbook of sediment transport by currents and waves," Report H461, Delft Hydraulics Laboratory, Delft, The Netherlands.
- Van Rijn, L. C. (1993). *Principles of sediment transport in rivers, estuaries and coastal seas*. Aqua Publications, Amsterdam, The Netherlands.
- Van Wijck, J., and Smits, J. (1991). "Underwater disposal of dredged material: A viable solution for the maintenance of dredging works in the River Scheldt," Bulletin No. 73, Permanent International Association of Navigation Congresses.
- Wang, X. Q., Thibodeaux, L. J., Valsaraj, K. T., and Reible, D. D. (1991). "Efficiency of capping contaminated bed sediments in situ. 1. Laboratory-scale experiments on diffusion-adsorption in the capping layer," *Environmental Science and Technology* 25(9).
- Westerink, J. J., Bain, C. C., Luettich, R. A., Jr., and Scheffner, N. W. (1994). "ADCIRC: An advanced three-dimensional circulation model for shelves, coasts and estuaries; Report 2, User's manual for ADCIRC-2DDI," Technical Report DRP-92-6, U.S. Army Engineer Waterways Experiment Station, Vicksburg, MS.
- Westerink, J. J., Luettich, R. A., and Scheffner, N. W. (1993). "ADCIRC: An advanced three-dimensional circulation model for shelves, coasts and estuaries; Report 3, Development of a tidal constituent data base for the western North Atlantic and Gulf of Mexico," Technical Report DRP-92-6, U.S. Army Engineer Waterways Experiment Station, Vicksburg, MS.
- White, P. (1972). "Sediment transport in channels: A general function," Report Int 104, Hydraulics Research Station, Wallingford, England.
- Wiley, M. B. (1994). "DAMOS capping model verification," DAMOS Contribution #89, Contract report written by Science Applications International Corporation for U.S. Army Engineer District, New England, Waltham, MA.
- _____. (1995). "Deep water capping," DAMOS Contribution #98, Contract report written by Science Applications International Corporation for U.S. Army Engineer District, New England, Waltham, MA.
- Williams, D. T. (1983). "Tampa Bay dredged material disposal site analysis," Miscellaneous Paper HL-83-8, U.S. Army Engineer Waterways Experiment Station, Vicksburg, MS.
- Wong, K. S., and Duncan, J. M. (1984). "CONSOL: A computer program for 1-D consolidation analysis of layered soil masses," Report No. UCB/GT/84-06, Department of Civil Engineering, University of California, Berkeley, CA.

Zeller, R. W., and Wastler, T. A. (1986). "Tiered ocean disposal monitoring will minimize data requirements," *Oceans '86*, Marine Technology Society, Washington, DC, 3, 1004-1009.

Zeman, A. J. (1993). "Subaqueous capping of very soft contaminated sediments." *Fourth Canadian Conference on Marine Geotechnical Engineering*, St. John's, Newfoundland.

Appendix A

Glossary of Terms

Aquatic environment - The geochemical environment in which dredged material is submerged underwater and remains water saturated after disposal is completed.

Aquatic ecosystem - Bodies of water, including wetlands, that serve as the habitat for interrelated and interacting communities and populations of plants and animals.

Baseline - Belt of the seas measured from the line of ordinary low water along that portion of the coast that is in direct contact with the open sea and the line marking the seaward limit of inland waters.

Bioaccumulation - The accumulation of contaminants in the tissues of organisms through any route, including respiration, ingestion, or direct contact with contaminated water, sediment, or dredged material.

Capping - The controlled, accurate placement of contaminated material at an open-water site, followed by a covering or cap of clean isolating material.

Coastal zone - Includes coastal waters and the adjacent shorelands designated by a State as being included within its approved coastal zone management program. The coastal zone may include open waters, estuaries, bays, inlets, lagoons, marshes, swamps, mangroves, beaches, dunes, bluffs, and coastal uplands. Coastal-zone uses can include housing, recreation, wildlife habitat, resource extraction, fishing, aquaculture, transportation, energy generation, commercial development, and waste disposal.

Confined disposal - Placement of dredged material within diked nearshore or upland confined disposal facilities (CDFs) that enclose the disposal area above any adjacent water surface, isolating the dredged material from adjacent waters during placement. Confined disposal does not refer to subaqueous capping or contained aquatic disposal.

Confined disposal facility (CDF) - An engineered structure for containment of dredged material consisting of dikes or other structures that enclose a disposal area above any adjacent water surface, isolating the dredged material from adjacent waters during placement. Other terms used for CDFs that appear in the literature include “confined disposal area,” “confined disposal site,” and “dredged material containment area.”

Contained aquatic disposal (CAD) - A form of capping that includes the added provision of some form of lateral containment (for example, placement of the contaminated and capping materials in bottom depressions or behind sub-aqueous berms) to minimize spread of the materials on the bottom.

Contaminant - A chemical or biological substance in a form that can be incorporated into or onto, or be ingested by, and that harms aquatic organisms, consumers of aquatic organisms, or users of the aquatic environment.

Contaminated sediment or contaminated dredged material - Contaminated sediments or contaminated dredged materials are defined as those that contain sufficient contaminants to warrant isolation from the benthic environment.

Disposal site or area - A precise geographical area within which disposal of dredged material occurs.

Dredged material - Material excavated from waters of the United States or ocean waters. The term dredged material refers to material that has been dredged from a water body, while the term sediment refers to material in a water body prior to the dredging process.

Dredged material discharge - The term dredged material discharge as used in this document means any addition of dredged material into waters of the United States or ocean waters. The term includes open-water discharges; discharges resulting from unconfined disposal operations (such as beach nourishment or other beneficial uses); discharges from confined disposal facilities that enter waters of the United States (such as effluent, surface runoff, or leachate); and overflow from dredge hoppers, scows, or other transport vessels.

Effluent - Water that is discharged from a confined disposal facility during and as a result of the filling or placement of dredge material.

Habitat - The specific area or environment in which a particular type of plant or animal lives. An organism's habitat provides all of the basic requirements for the maintenance of life. Typical coastal habitats include beaches, marshes, rocky shores, bottom sediments, mudflats, and the water itself.

Leachate - Water or any other liquid that may contain dissolved (leached) soluble materials, such as organic salts and mineral salts, derived from a solid material. For example, rainwater that percolates through a confined disposal facility and picks up dissolved contaminants is considered leachate.

Level bottom capping (LBC) - A form of capping in which the contaminated material is placed on the bottom in a mounded configuration.

Open-water disposal - Placement of dredged material in rivers, lakes, estuaries, or oceans via pipeline or surface release from hopper dredges or barges.

Sediment - Material, such as sand, silt, or clay, suspended in or settled on the bottom of a water body. Sediment input to a body of water comes from natural sources, such as erosion of soils and weathering of rock, or as the result of anthropogenic activities, such as forest or agricultural practices, or construction activities. The term dredged material refers to material that has been dredged from a water body, while the term sediment refers to material in a water body prior to the dredging process.

Suspended solids - Organic or inorganic particles that are suspended in water. The term includes sand, silt, and clay particles as well as other solids, such as biological material, suspended in the water column.

Territorial sea - The strip of water immediately adjacent to the coast of a nation measured from the baseline as determined in accordance with the Convention on the territorial sea and the contiguous zone (15 UST 1606; TIAS 5639) and extending a distance of 3 nmi from the baseline.

Toxicity - Level of mortality or other end point demonstrated by a group of organisms that have been affected by the properties of a substance, such as contaminated water, sediment, or dredged material.

Toxic pollutant - Pollutants, or combinations of pollutants, including disease-causing agents, that after discharge and upon exposure, ingestion, inhalation, or assimilation into any organism, either directly from the environment or indirectly by ingestion through food chains, will, on the basis of information available to the Administrator of the U.S. Environmental Protection Agency, cause death, disease, behavioral abnormalities, cancer, genetic mutations, physiological malfunctions, or physical deformations in such organisms or their offspring.

Turbidity - An optical measure of the amount of material suspended in the water. Increasing the turbidity of the water decreases the amount of light that penetrates the water column. High levels of turbidity can be harmful to aquatic life.

Appendix B

Model for Chemical Containment by a Cap

by Dr. Danny D. Reible,
Louisiana State University¹

Introduction

This appendix describes a model for evaluation of chemical flux through a cap. Through use of this model, the effectiveness of chemical containment of a cap can be assessed. This model should be applied once remediation objectives are determined, a specific capping material has been selected and characterized, and a minimum cap thickness has been determined based on components for isolation, bioturbation, and consolidation. If the objective of the cap is attainment of a given contaminant flux, the model can be used to estimate the required cap thickness.

This model assumes that the cap is armored such that erosion of the cap does not provide the primary means of contaminant migration. Instead, the contaminants contained within the pore water of the sediment are available to migrate into the cap and subsequently into the overlying water. The pore water concentration, C_{pw} , is always assumed in a state of local equilibrium that is related to the sediment contaminant loading, ω_{sed} , milligrams contaminant per kilogram dry sediment, through an observed partition coefficient, K_d^{obs} , as

$$\omega_{sed} = K_d^{obs} C_{pw} \quad (B1)$$

Thus the initial pore water concentration in the sediment, C_0 , is given by

$$C_0 = C_{pw} = \frac{\omega_{sed}}{K_d^{obs}} \quad (B2)$$

¹ This appendix is identical to Appendix B of the report entitled "Guidance for In-Situ Subaqueous Capping of Contaminated Sediments" (Palermo et al. 1996).

The difference between this concentration and the concentration in the overlying water defines the driving force for contaminant release to that water. In addition, it is normally this concentration that defines the sediment quality criteria because it is this concentration that defines the contaminant levels to which benthic organisms are exposed. Benthic organisms are generally the most sensitive organisms in the sediment environment, and any contaminants that they may accumulate may be transferred higher in the food chain. Isolation of contaminants from these benthic organisms is one of the most important motivations for placement of a cap. The objective is to place a cap of sufficient thickness to realize this isolation.

Relationship Between Sediment and Pore Water Concentrations

Equation B1 defines an observed partition coefficient between the sediment and the adjacent pore water. Use of a measured partition coefficient does not require linearity or reversibility of the sorption isotherm, nor does it require specification of the form of the contaminant in the pore water (e.g., dissolved or bound to particles). For a compound that sorbs to soil with an observed partition coefficient of K_d^{obs} (liters/kilogram), the ratio of the total concentration in the soil to that in the pore water is given by the retardation factor, R_f ,

$$R_f = \epsilon + \rho_b K_d^{obs} \quad (\text{B3})$$

The retardation factor is so named because contaminant migration in the pore water is slowed by the sorption onto the immobile sediment phase.

The value of K_d^{obs} for either the sediment or the cap should be determined directly by evaluating the ratio of sediment or cap loading to pore water concentration. In the absence of direct measurement of pore water concentrations, however, the value of K_d^{obs} can be estimated for hydrophobic organic compounds that tend to sorb reversibly and nonselectively upon organic matter in the sediment or pore water. For these compounds, the observed partition coefficient can be normalized by the amount of organic carbon present in the sediment or pore water to define a “universal” partition coefficient, K_{oc} , that should be constant for a particular compound. Given such a contaminant at concentration ω_{sed} in the sediment, the concentration dissolved in the pore water is given by

$$C_{diss} = \frac{\omega_{sed}}{K_{oc} f_{oc}} \quad (\text{B4})$$

Here f_{oc} is the fraction organic carbon in the sediment in mass organic carbon per mass dry sediment. The same relation applies to the capping material if the concentrations and properties are characteristic of the cap rather than the underlying sediment.

In addition, the water in the pores contains contaminant sorbed to organic carbon (dissolved or particulate organic carbon present at concentration ρ_{oc} , e.g., in milligrams/liter). To a first approximation, the partitioning to this suspended organic matter is also governed by the organic carbon based partition coefficient, K_{oc} , and thus the total pore water concentration for that compound is given by

$$\begin{aligned} C_{pw} &= C_{diss} (1 + \rho_{oc} K_{oc}) \\ &= \frac{\omega_{sed}}{K_{oc} f_{oc}} (1 + \rho_{oc} K_{oc}) \end{aligned} \quad (B5)$$

Note, however, that the truly dissolved concentration can never exceed the solubility of the contaminant in water, C_w^* , and therefore the pore water concentration is bounded by

$$C_{pw} \leq C_w^* (1 + \rho_{oc} K_{oc}) \quad (B6)$$

As a result of this limit, there exists a critical sediment loading, ω_{crit} , above which the contaminant concentration in the pore water is independent of the sediment loading. The dissolved concentration is always given by the water solubility under these conditions, and the total pore water concentration is given by the equality in Equation B5.

$$\omega_{crit} = K_{oc} f_{oc} C_w^* \quad (B7)$$

$$\text{For } \omega_{sed} > \omega_{crit} \quad C_{pw} = C_w^* (1 + \rho_{oc} K_{oc})$$

Thus the observed sediment-water partition coefficient for a hydrophobic organic compound is given by

$$\begin{aligned} K_d^{obs} &= \frac{\omega_{sed}}{C_0} && \text{if measurements are available} \\ &= \frac{K_{oc} f_{oc}}{(1 + \rho_{oc} K_{oc})} && \text{estimate if } \omega_{sed} \leq \omega_{crit} \\ &= \frac{\omega_{sed}}{C_w^* (1 + \rho_{oc} K_{oc})} && \text{estimate if } \omega_{sed} \geq \omega_{crit} \end{aligned} \quad (B8)$$

Effective Thickness of a Cap

The effective thickness, L_{eff} , of a cap is reduced by consolidation of the cap, ΔL_{cap} , consolidation in the underlying sediment, ΔL_{sed} , and by bioturbation over a depth, L_{bio} . Bioturbation, the normal life-cycle activities of benthic organisms, leads to mixing and redistribution of contaminants and sediments in the upper layer. The chemical migration rate within the bioturbated zone is typically much faster than in other portions of a cap. In addition, consolidation typically occurs

on a time scale that is rapid compared with the design lifetime of a cap. Consolidation of the cap directly reduces the thickness of a cap and the separation between contaminants and the overlying water or benthic organisms while consolidation of the underlying sediment results in the expression of potentially contaminated pore water. Using $\Delta L_{sed,A}$ to represent the thickness of a cap compromised by a contaminant *A* during consolidation of the underlying sediment, the effective cap thickness remaining for chemical containment is given by

$$L_{eff} = L_0 - L_{bio} - \Delta L_{cap} - \Delta L_{sed,A} \quad (B9)$$

where L_0 is the initial thickness of the cap immediately after placement.

The depth of bioturbation can be assessed through an evaluation of the capping material and recognition of the type, size, and density of organisms expected to populate this material. Because of the uncertainty in this evaluation, the bioturbated zone is generally chosen conservatively, that is, considered to be as large as the deepest penetrating organism likely to be present. Due to the action of bioturbating organisms, this layer is also generally assumed to pose no resistance to mass transfer between the contaminated sediment layer and the overlying water.

The consolidation of a cap can be estimated through use of standard consolidation models; for example, the Corps of Engineers' Primary Consolidation and Dessiccation of Dredged Fill (PCDDF) model (Stark 1991). Note, however, that in addition to reducing the thickness of a cap, consolidation serves to reduce both the porosity and permeability of a cap causing reductions in chemical migration rates by both advection and diffusion.

The consolidation of the underlying contaminated sediment can also be estimated through consolidation models. These models do not predict the resulting movement of the chemical, however, and a model is described below. The effective cap thickness estimated by Equation B9 is subject to chemical migration by advection and diffusion processes. The long-term chemical flux to the water via these processes can be modeled.

The complete model of chemical movement through the cap must be composed of two components:

- An advective component considering the short-term consolidation of the contaminated sediment underlying the cap.
- A diffusive or advective-dispersive component considering contaminant movement as a result of pore water movement after the cap has fully consolidated.

The first component is operative for all caps but only for a short period of time. The first component allows determination of the effective cap thickness through Equation B9. The resulting effective cap thickness can then be used to assess long-term losses through the cap by advective and/or diffusive processes.

For simplicity and conservatism, the sediment underlying a cap may be assumed to remain uniformly contaminated at the concentration levels prior to cap placement. In reality, migration of contaminants into the cap reduce the sediment concentration and the long-term flux to the overlying water. The consideration of this situation, however, complicates the analysis and the models used to describe contaminant flux. Analytical models are presented for the case of constant concentration in the underlying sediment. The results of a numerical model that incorporates the depletion of the underlying sediment concentrations are referenced for comparison.

Model for Short-Term Cap Losses—Advection During Cap Consolidation

After placement of capping materials, consolidation of both the cap and the underlying sediment occurs. Consolidation of the cap results in no contaminant release since the cap is initially free of contamination. Furthermore, the consolidation of the cap serves to reduce the permeability and, to a lesser extent, the porosity of a cap. Both serve to reduce contaminant migration through the cap by both diffusive and advective processes.

Consolidation of the underlying sediment due to the weight of the capping material, however, tends to result in expression of pore water and the contaminants associated with that water. The ultimate amount of consolidation may be estimated using standard methods; for example, the previously referenced PCD model. The consolidation of the underlying sediment is likely to occur over a short period (e.g., months) compared with the lifetime of the cap. It is appropriate, therefore, to assume that the consolidation occurs essentially instantaneously and estimate the resulting contaminant migration solely on the basis of the total depth of consolidation and the pore water expressed. For a nonsorbing contaminant, the penetration depth of the chemical is identical to that of the expressed pore water. For a sorbing contaminant, the penetration depth is less as a result of the accumulation of chemical on the sediment.

Mathematically, if ΔL_{sed} represents the ultimate depth of consolidation of the underlying contaminated sediment due to cap placement, the depth of cap affected by this pore water (or nonsorbing contaminant), $\Delta L_{sed,pw}$, is given by

$$\Delta L_{sed,pw} \approx \frac{\Delta L_{sed}}{\epsilon} \quad (B10)$$

where ϵ is the porosity of the cap materials. The division by the cap porosity recognizes that the expressed pore water moves only through the void volume formed by the spaces between the grains of the capping material. Equation B10 assumes that the capping material is spatially uniform and that pore water is not preferentially forced through a small fraction of the total cap area.

Although the depth of cap affected by the expressed pore water is given by Equation B10, the migration distance of a sorbing contaminant is less due to

accumulation in the cap. The quantity of contaminant that can be rapidly adsorbed by the cap material, ω_{cap} (milligrams/kilogram dry cap material), is generally assumed to be proportional to the concentration in the pore water (C_{pw} , milligrams/liter),

$$\omega_{cap} = K_{d, cap}^{obs} C_{pw} \quad (B11)$$

where the constant of proportionality is the observed sediment-water partition coefficient in the cap. Note that the observed partition coefficient is measured during sorption onto clean cap material since this is the conditions that occur after placement of a clean cap onto contaminated sediment. The maximum quantity that can be sorbed by the cap is given by the product of the observed partition coefficient and the initial pore water concentration of the contaminant in the underlying sediment, C_0 .

As a result of sorption onto the immobile sediment, the distance that the contaminant migrates in the cap during consolidation of the underlying sediment by a distance ΔL_{sed} is given by

$$\Delta L_{sed, A} \approx \frac{\Delta L_{sed}}{R_f} \approx \frac{\Delta L_{sed}}{\epsilon + \rho_b K_{d, cap}^{obs}} \quad (B12)$$

This distance must be subtracted from the actual cap thickness to estimate effective cap thickness. Note that this model suggests that the more sorbing a cap, the less important is consolidation in the underlying sediment. Sorption for hydrophobic organics such as polyaromatic hydrocarbons and polychlorinated biphenyls is strongly correlated with the organic carbon content of the sediments. $K_{d, cap}^{obs}$ is typically of the order of hundreds or thousands for these compounds; if a cap contains 0.5-percent organic carbon or more, the loss of effective cap thickness due to penetration of the contaminant is a small fraction of the sediment consolidation distance. Metals also tend to be strongly associated with the solid fraction, again reducing the migration of contaminant out of the sediment as a result of consolidation.

Estimation of Long-Term Losses

Mechanisms and driving force

The effective cap thickness defined by Equation B9 is subject to advection or diffusion or a combination of both throughout the lifetime of the cap. The long-term contaminant release or loss requires estimation of the contaminant flux by these processes. Diffusion is always present, while advection only occurs if there exists a significant hydraulic gradient in the underlying sediments. The relative magnitude of diffusion to advection in the cap of effective thickness, L_{eff} can be estimated by the Peclet number.

$$Pe = \frac{U_{pw} L_{eff}}{D_{eff}} \quad (B13)$$

where

U_{pw} = advective velocity (Darcy or superficial velocity) in the sediment

D_{eff} = effective diffusion/dispersion coefficient

If the magnitude or absolute value of the Peclet number is much greater than one, advection dominates over diffusion/dispersion, while the opposite is true for absolute values much less than one. Advection directed out of the cap will speed contaminant release, while advection directed into the sediment will effectively lengthen the cap.

The average groundwater flow velocity is estimated from the sediment conductivity (K , centimeters/second) or permeability (K , square centimeters) and the local hydraulic gradient.

$$U_{pw} = -K \frac{\partial h}{\partial z} = -\frac{k\rho g}{\mu} \frac{\partial h}{\partial z} \quad (B14)$$

where

ρ = density of water ($\sim 1 \text{ g/cm}^3$)

g = acceleration of gravity ($980 \text{ cm}\cdot\text{sec}^{-2}$)

μ = viscosity of water ($\sim 0.01 \text{ g}\cdot\text{cm}^{-1}\cdot\text{sec}^{-1}$)

$\frac{\partial h}{\partial z}$ = local gradient in hydraulic head with distance into sediment

The minus sign recognizes that the groundwater flow is to regions of lesser hydraulic head. The average groundwater flow is the volumetric seepage rate (volume/time) divided by the sediment-water interfacial area. Thus, lakes with large sediment-water interfacial areas tend to exhibit less potential for advective influences than small streams. Estuarine systems subject to significant tidal fluctuations may also exhibit significant advective transport. Losing streams, in which the advective transport is into the sediment, may exhibit advection but may not be important since the direction of transport is away from the sediment-water interface and long travel distances may be required to impact groundwater of significance. Similarly, advection may be less important in wetlands subject to frequent cycles of flooding followed by infiltration due to the downward vector of advection. The presence of a cap will tend to reduce any advective transport by preferentially channeling flow to uncapped sediment. The permeability of the cap materials may also be selected or modified to minimize advection.

The effect of advection includes both transport by the pore water flow and that by diffusion and dispersion. Dispersion is the additional “diffusion-like” mixing relative to the average pore water velocity that occurs as a result of heterogeneities in the sediments. Thus the description of advection is more complicated than diffusion, and the model for long-term cap losses will be subdivided into models appropriate only when diffusion dominates and models when both advection and diffusion/dispersion are important.

Both processes are operative only for that portion of the contaminant present in the pore water as measured by the concentration C_0 . This might include contaminant dissolved in the pore water as well as contaminant sorbed to fine particulate or colloidal matter suspended in the pore water. The best measure of this concentration is through direct pore water measurements. In the absence of pore water measurements, however, linear reversible sorption can be assumed and Equations B5 or B7 apply,

$$C_0 = \begin{cases} \frac{\omega_{sed}}{K_{oc} f_{oc}} (1 + \rho_{oc} K_{oc}) & \text{if } \omega_{sed} \leq \omega_{crit} \\ C_w^* (1 + \rho_{oc} K_{oc}) & \text{if } \omega_{sed} \geq \omega_{crit} \end{cases} \quad (B15)$$

where

C_w^* = equilibrium solubility of chemical in water

ω_{sed} = sediment loading (milligrams chemical/kilogram (dry) sediment)

Equation B15 indicates that the pore water concentration increases linearly with the sediment loading until the water is saturated, that is, until the solubility limit is reached. This limit is the normal water solubility adjusted for the sorption onto organic matter in the pore water.

Degradation of contaminants over the long time of expected confinement is a significant benefit of capping that should be incorporated into the design of a cap. Polyaromatic hydrocarbons as well as chlorinated aliphatic and aromatic compounds all exhibit slow but finite rates of degradation or transformation in the generally anaerobic environment beneath a cap. If simple first order degradation kinetics is employed, the sediment loading changes with time according to

$$\omega_{sed} = \omega_{sed}^0 e^{-k_r t} \quad (B16)$$

where

ω_{sed}^0 = sediment loading at time of cap placement

k_r = exponential time constant given by $0.693/t_{0.5}$

$t_{0.5}$ = chemical half life in sediment

In the absence of dependable data on rates of degradation or transformation, the conservative assumption of no contaminant depletion is generally assumed.

In the subsequent sections, the movement of contaminants from the sediments through the cap by both diffusion and advection are evaluated. The focus is on the development of simple analytical models that can be expressed in algebraic form. This generally limits the conditions evaluated to uniform sediment and cap physical and chemical properties and an initial contaminant concentration that is both uniform in the sediment and constant. Depletion of contaminant in the sediment by either chemical degradation or mass depletion as a result of the release of material through the cap is not considered. The models are thus conservative indicators of contaminant release from the sediment (that is, they overestimate the concentration in the sediment or the flux of contaminant to the overlying water column).

Diffusion

Diffusion is a process that occurs at significant rates only within the pores of the sediment and is driven by the difference in pore water concentration between the sediment and the cap. The initial concentration of the contaminant in the cap pore water is generally zero, while the concentration in the sediment is given by Equation B15. Even without degradation, however, migration of contaminants into the cap will deplete the underlying sediments as a result of the loss of mass by diffusion through the cap.

Thoma et al. (1993) developed a model of diffusion through a cap that explicitly accounts for depletion in the underlying sediment. A simpler model of diffusion through the cap, however, assumes that the contaminant concentration in the underlying sediment is essentially constant. This would be most appropriate if the contaminant concentration in the sediment far exceeds the critical concentration defined by Equation B7. Because the assumption of no depletion in the underlying sediment overpredicts the driving force for diffusion, and therefore the flux through the cap, it represents a conservative assumption of the effectiveness of the cap. It will therefore be employed in the description that follows.

One should first estimate the steady long-term flux of contaminants through the cap via diffusion. This is the maximum flux that can occur through the cap by the diffusive mechanism.

Maximum flux estimation (steady state)

If diffusion is the only operative transport process through the cap, the pseudo steady-state flux through the cap (assuming constant contaminated sediment pore water concentration and no sorption effects in the cap layer) is given by

$$F = \frac{D_{eff}}{L_{eff}} (C_0 - C_w) \approx K_{cap} (C_0 - C_w) \quad (B17)$$

where

F = chemical flux, $\text{ng}\cdot\text{cm}^{-2}\cdot\text{sec}^{-1}$

D_{eff} = effective binary diffusivity of chemical in cap, cm^2/sec

ε = sediment porosity (void volume/total volume)

L_{eff} = effective cap thickness

C_0 = pore water concentration in sediment beneath cap including dissolved and sorbed to colloidal species, ng/cm^3

C_w = total contaminant concentration in overlying water, ng/cm^3

K_{cap} = effective mass transfer coefficient through cap, cm/sec

The effective diffusion coefficient is generally estimated by the equation of Millington and Quirk (1961)

$$D_{eff} = D_w \varepsilon^{4/3} \quad (B18)$$

where

D_w = molecular diffusivity of compound in water

ε = void fraction or porosity of sediment

Millington and Quirk suggest the factor $\varepsilon^{4/3}$ to correct for the reduced area and tortuous path of diffusion in porous media.

In general, the chemical flux is influenced by bioturbation and a variety of water column processes. Figure B1 shows the definitions of fluxes in a capped system at this pseudo steady state. The flux of chemical through each layer is equal to the sum of the rate of evaporation and flushing. Mathematically, in terms of mass transfer coefficients, one has:

$$\begin{aligned} M &= K_{ov} A_s C_0 = K_{cap} A_s (C_0 - C_{bio'}) = K_{bio} A_s (C_{bio} - C_{sw}) \\ &= K_{bl} A_s (C_{sw} - C_w) = (K_e A_e + Q) C_w \end{aligned} \quad (B19)$$

where

M = rate of chemical loss from system, $\text{mg}/\text{day} = F \cdot A_s$

K_{ov} = overall mass transfer coefficient, cm/day

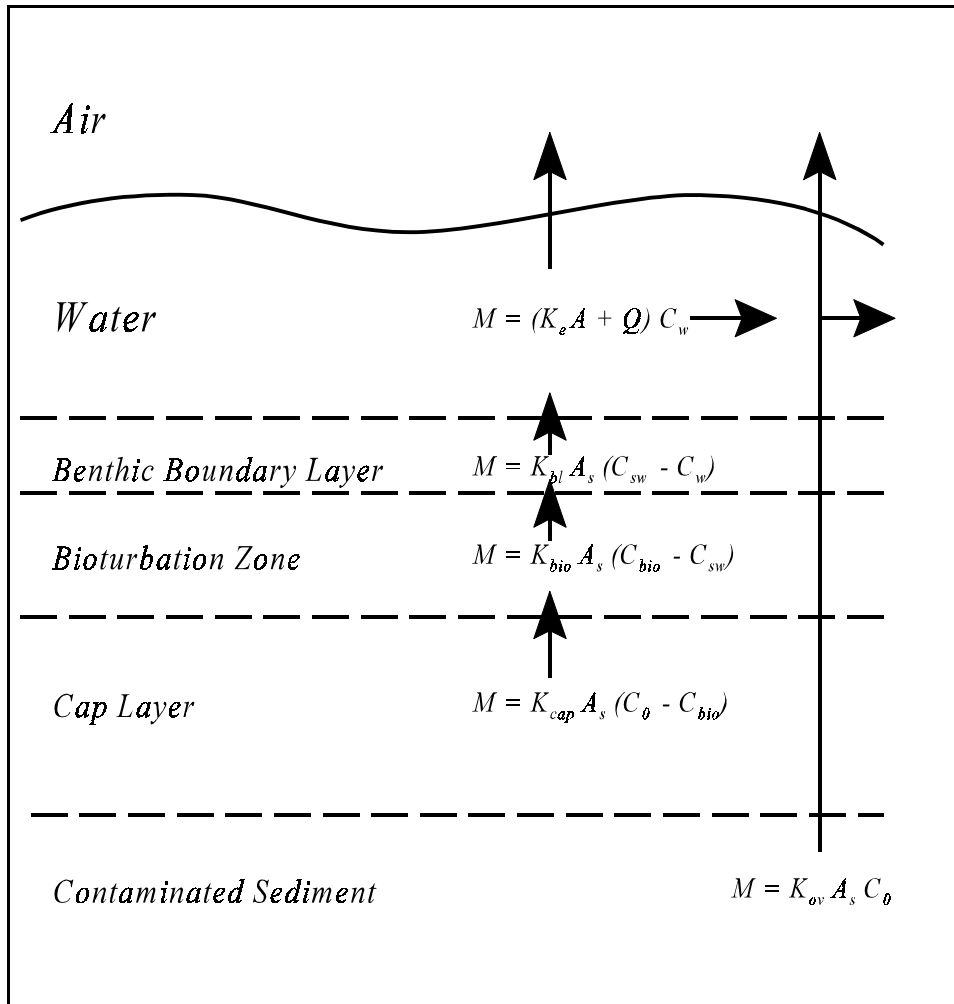

Figure B1. Idealized multilayer contaminant release rates showing individual and overall mass transfer coefficient definitions

A_s = contaminated sediment area, m^2

A_e = evaporative surface area, m^2

C_0 = pore water concentration within contaminated sediment including dissolved and any sorbed to colloidal material

K_{cap} = cap mass transfer coefficient = $D_w \epsilon^{4/3} / L_{eff}$, cm/day

C_{bio} = pore water concentration at top of cap, ng/cm^3

K_{bio} = bioturbation mass transfer coefficient = $\frac{\eta D_{bio} R_f}{L_{bio}}$, cm/day

C_{sw} = pore water concentration at sediment water interface, ng/cm³

η = desorption efficiency of contaminant from sediment particles

D_{bio} = biodiffusion coefficient, cm²/day

R_f = retardation factor = $\epsilon + \rho_B K_d^{obs}$

L_{bio} = depth of bioturbation, cm

K_{bl} = benthic boundary layer mass transfer coefficient, cm/day

K_e = evaporation mass transfer coefficient, cm/day

D_e = effective diffusivity = $D_w \cdot \epsilon^{4/3}$, cm³/day

Q = basin flushing rate, cm³/day

C_w = chemical concentration in the overlying water, ng/cm³

K_d = sediment water partition coefficient for chemical = $K_{oc} f_{oc}$, cm³/g

K_{oc} = organic carbon-water coefficient for chemical, cm³/g

f_{oc} = sediment fractional organic carbon content

ρ_B = sediment bulk density

The overall mass transfer coefficient, K_{ov} , can be obtained from the following

$$\frac{1}{K_{ov}} = \frac{1}{K_{cap}} + \frac{1}{K_{bio}} + \frac{1}{K_{bl}} + \frac{A_s}{K_e A_e + Q} \quad (\text{B20})$$

An analysis of this relationship for reasonable values of L_{eff} suggests that $1/K_{ov} \cong 1/K_{cap}$; therefore, the cap controls the flux to the overlying water, and Equation B17 is valid.

This flux can be used to estimate concentrations in the water (C_w) or at the sediment water interface (C_{sw}) or multiplied by the capped area to determine total release rate. For hydrophobic organics, the concentration in the overlying water at steady state is defined by a balance between the flux through the cap, the rate of evaporation to the air, and the rate of flushing of the water column. For metals and elemental species not associated with volatile compounds, the flux through the cap is balanced only with the flushing of the water column. The overlying water concentration of the contaminant is given by:

$$C_w = \left(\frac{K_{ov} A_s}{K_e A_\ell + Q} \right) C_0 \quad (\text{B21})$$

The concentration at the cap-water interface, which would be indicative of the level of exposure of bottom-surface dwelling organisms, is defined by the balance of the flux through the cap with the flux through the benthic boundary layer. The contaminant concentration at the cap-water interface is:

$$C_{cw} = \frac{K_{ov} C_0}{K_{bl}} + C_w \quad (\text{B22})$$

Either of these concentrations or the estimated fluxes may be compared with applicable criteria for the chemical in question to determine if a specified cap thickness is adequate.

Transient diffusion—breakthrough time estimation

The simple steady-state analysis presented above is not capable of predicting the time required for the contaminant(s) to migrate through the cap layer. Until sorption and migration in the cap is complete, the flux to the water column will be less than predicted by Equation B17. Addressing this problem requires incorporation of time explicitly in the differential mass balance. The following partial differential equation represents a differential mass balance on the contaminant in the pore water of the cap as it diffuses from the contaminated sediment below.

$$R_f \frac{\partial C_{pw}}{\partial t} = D_w \epsilon^{4/3} \frac{\partial^2 C_{pw}}{\partial z^2} \quad (\text{B23})$$

The conditions of a constant concentration at the sediment-cap interface are applied as specified by Equation B15 and the concentration of the overlying water at the height L_{eff} in the cap. Carslaw and Jaeger (1959) present a solution to the equivalent heat transfer problem that in terms of concentration and mass diffusion can be written

$$F_{diff} = \frac{(C_0 - C_w) D_{eff}}{L_{eff}} \left[1 + 2 \sum_{n=1}^{\infty} (-1)^n \exp \left(- \frac{D_{eff} \{n\pi\}^2 t}{R_f L_{eff}^2} \right) \right] \quad (\text{B24})$$

where D_{eff} represents $D_w \epsilon^{4/3}$. This solution is also given in this form by Thoma et al. (1993). Note that as $t \rightarrow \infty$, the exponential term approaches zero and the flux approaches the value obtained by the approximation $K_{ov} \approx D_{eff} / L_{eff}$ as indicated by Equation B17. From Equation B24, one can obtain relations for the breakthrough time and the time required to approach the steady-state flux.

Breakthrough time, τ_b , is defined as the time at which the flux of contaminant from the contaminated sediment layer has reached 5 percent of its steady-state

value, and the time to reach steady state, τ_{ss} , is defined as the time when the flux is 95 percent of its steady-state value. It is easily shown that

$$\tau_b = \frac{0.54 L_{eff}^2 R_f}{D_w \epsilon^{4/3} \pi^2} \quad (B25)$$

and

$$\tau_{ss} = \frac{3.69 L_{eff}^2 R_f}{D_w \epsilon^{4/3} \pi^2} \quad (B26)$$

Advective-dispersive models

When advection cannot be neglected during the operation of a cap, the basic equation governing contaminant movement is

$$R_f \frac{\partial C_{pw}}{\partial t} + U \frac{\partial C_{pw}}{\partial z} = D_{disp} \frac{\partial^2 C_{pw}}{\partial z^2} \quad (B27)$$

where

C_{pw} = contaminant concentration in pore water

$U = U_{pw}$ = Darcy velocity directed outward

D_{eff} = effective diffusion/dispersion coefficient

The effective diffusion/dispersion coefficient is often modeled by a relationship of the form (Bear 1979)

$$\begin{aligned} D_{disp} &= D_{eff} + \alpha U \\ &\approx D_w \epsilon^{4/3} + \alpha U \end{aligned} \quad (B28)$$

The first term in this relation is associated with molecular diffusion and is again modeled by the Millington and Quirk (1961) relation. The second term is mechanical dispersion associated with the additional mixing due to flow variations and channeling. α is the dispersivity and is typically taken to be related to the sediment grain size (uniform sandy sediments) or travel distance (heterogeneous sediments). Little guidance exists for the estimation of field dispersivities for vertical flow in sediments. In uniform sandy sediments, the longitudinal dispersivity is approximately one-half the grain diameter, while the transverse dispersivity tends to be an order of magnitude smaller (Bear 1979). Dispersion in heterogeneous sediments would be expected to be larger than these estimates.

If the effective dispersivity can be estimated, the contaminant concentration and flux through the cap can be estimated by solutions to Equation B27. One

should first consider the long-time behavior of Equation B27 when the sediment originally exhibits a contaminant pore water concentration C_0 . If the contaminant is not subject to significant depletion by either degradation or migration through the cap, the flux through the cap ultimately reaches that given by

$$F_{adv} \rightarrow U (C_0 - C_w) \quad \text{as } t \rightarrow \infty \quad (\text{B29})$$

That is, the contaminant flux due to advection approaches that which would be observed if no cap were placed over the sediment. In such a situation, the cap can be viewed only as a temporary confinement measure until the sediment is removed or depletion renders the contaminant harmless. It should be emphasized, however, that this will only occur when depletion of contaminant in the capped sediment is negligible, a conservative assumption that may significantly overestimate the flux of contaminant through the cap. This assumption is compared with more realistic approaches in an example below.

In the advection-dominated case, it is important to examine the transient release of the contaminant. The conditions on Equation B27 that are appropriate for a cap include

$$\begin{aligned} \text{cap-sediment interface } (z=0) & \quad C_{pw} = C_0 \\ \text{cap-water interface } (z=L_{eff}) & \quad C_{pw} = C_w \quad (\text{Generally } C_w \approx 0) \quad (\text{B30}) \\ \text{initial cap concentration} & \quad C_{pw} = C_w \end{aligned}$$

Available analytical solutions describe only homogeneous cap properties and do not satisfy the cap-water interface condition of Equation B30. Instead there are two approximate conditions that are commonly applied instead of the cap-water interface condition.

$$\begin{aligned} \frac{\partial C_{pw}}{\partial z} = 0 & \quad \text{at } z = L_{eff} \quad (\text{finite cap}) \\ \frac{\partial C_{pw}}{\partial z} = 0 & \quad \text{as } z \rightarrow \infty \quad (\text{infinite cap}) \end{aligned} \quad (\text{B31})$$

The first explicitly recognizes the finite thickness of the cap, while the second assumes that it is infinitely thick. The solution subject to the finite boundary condition is given by Cleary and Adrian (1973), while the solution subject to the infinite boundary condition can be found in Carslaw and Jaeger (1959). For $Pe > 1$, however, the concentration and flux predictions of either model are essentially identical. Moreover, for $Pe < 1$ when diffusion dominates, the given finite cap condition is inappropriate and causes the solution to underpredict the contaminant flux through the cap. The solution for the infinite cap is also simpler to use. For these reasons, only the infinite cap model will be described in this section. However, the full boundary conditions of Equation B30 or heterogeneous sediment properties can be described using numerical solvers as illustrated in the example.

The solution to Equation B27 subject to the infinite cap condition in homogeneous sediment is given by

$$C_{pw}(z,t) = \frac{(C_0 - C_w)}{2} \left[\operatorname{erfc} \left(\frac{R_f z - Ut}{2\sqrt{R_f D t}} \right) + \exp \left(\frac{Uz}{D} \right) \operatorname{erfc} \left(\frac{R_f z + Ut}{2\sqrt{R_f D t}} \right) \right] \quad (\text{B32})$$

Here *erfc* represents the complementary error function that is given by $1 - \operatorname{erf}$, the error function. The error function is a tabulated function (e.g., Thibodeaux 1996) and is commonly available in spreadsheets and computer languages. It ranges from 0 at a value of the argument equal to zero to 1 at a value of the argument equal to infinity. The model is most useful in predicting the penetration of the contaminant into the cap and the time until the sediment-water interface begins to be significantly influenced by the cap, i.e., the breakthrough time. The breakthrough time can be estimated by evaluating Equation B32 for $z = L_{eff}$ and determining the time required until $C_{pw}(L_{eff}, t)$ is equal to some fixed fraction of the concentration in the underlying sediment; for example, until $C_{pw}(L_{eff}, t) = 0.05 C_0$. The flux into the overlying water at any time could also be evaluated by computing

$$F(L_{eff}, t) = U C_{pw}(L_{eff}, t) - D_{eff} \frac{\partial C_{pw}(L_{eff}, t)}{\partial z} \quad (\text{B33})$$

Note that Equations B32 and B33 can also be applied to conditions of mild erosion or deposition on the cap. Erosion or deposition give rise to an effective velocity directed downward with deposition and upward with erosion. Because erosion buries or uncovers sediment and its associated contaminants, the effective velocity influencing the pore water concentration is the erosion or deposition velocity multiplied by the retardation factor.

$$U = \begin{array}{ll} U_{pw} + U_{erosion} R_f & \text{Erosion} \\ U_{pw} - U_{deposition} R_f & \text{Deposition} \end{array} \quad (\text{B34})$$

That is, sediment burial or deposition gives rise to a rapid burial or exposure of contaminants as a result of the sorbed load on the sediment particles.

Models for More General Cases: Numerical Solutions

All of the models discussed thus far assume that the concentration in the sediment remains unchanged despite the loss of contaminant to the overlying water. This simplification is necessary to apply the presented analytical solutions but leads to overly conservative results. For example, in an advective dominated system, Equation B29 will describe the flux to the overlying water at long time only if depletion is not accounted for. It should be emphasized that the

depletion referred to here is simply accounting for the mass of contaminant lost to the overlying water. Degradation of the contaminant is not considered.

To overcome this limitation of the preceding models, it is necessary to turn to a numerical simulation of Equation B27. The numerical simulation should apply Equation B27 both within the cap and in the underlying sediment assuming that the concentrations and fluxes are continuous at the sediment water interface. Arbitrary initial and boundary conditions could be applied. For the particular case of an initially clean sediment cap overlying a finite layer of contaminated sediment, the author has developed such a numerical solution. This model is coded in FORTRAN and employs IMSL subroutines to conduct the numerical calculations. An illustrative example using the model is presented later as is a contact address for acquisition of the model.

Models for Uncapped Sediment

Although the primary purpose is the evaluation of contaminant concentrations and fluxes associated with capped sediment, it is often convenient to compare these quantities with concentrations and fluxes that would be observed in the absence of a cap. Models similar to those above are available for uncapped conditions and are especially useful for comparison purposes.

Let us consider the solution to Equation B27 subject to the uncapped boundary conditions

$$\begin{aligned}
 \text{sediment-water interface } (z=0) \quad C_{pw} &= C_w \\
 \text{deep sediment } (z \rightarrow \infty) \quad C_{pw} &= C_0 \text{ or } \frac{\partial C_{pw}}{\partial z} \rightarrow 0 \\
 \text{initial sediment concentration} \quad C_{pw} &= C_0
 \end{aligned} \tag{B35}$$

These are the same conditions, however, as those leading to Equation B32 if the z coordinate is directed into the sediment rather than out through the cap and if the roles of C_0 and C_w are reversed. Thus Equation B32 can be used to evaluate concentrations in the uncapped case as well. Both the sense of U and z must be reversed, and $z = 0$ now represents the sediment-water interface. Similarly, the flux from the sediment to the overlying water is given by

$$F(0,t) = U C_{pw}(0,t) - D_{eff} \frac{\partial C_{pw}(0,t)}{\partial z} \tag{B36}$$

Similarly, finite contaminated layer models could be adapted from Equation B24. This would not be a fair basis for comparison, however, in that the uncapped model would explicitly account for depletion of the sediment contaminants as a result of the loss to water while the cap version of the solution assumes that the sediment concentration remains constant.

Parameter Estimation

Use of any of the above models requires estimation of a variety of model parameters. The most important of these parameters and an example calculation are presented below. These include the porosity (ϵ), bulk density (ρ_b), and organic carbon content (f_{oc}) of the cap material; the partition coefficient (K_d) for the chemical(s) between the pore water and the cap material; the diffusivity of the chemical(s) in water (D_w); the depth of bioturbation (L_{bio}) and a biodiffusion coefficient (D_{bio}); benthic boundary layer (K_{bl}) and evaporation (K_e) mass transfer coefficients; and for flowing systems, the water flushing rate (Q). Information should be obtained on the degradation half-life or reaction rate of chemicals of concern in the specific project if such information is available.

Contaminant properties

Contaminant properties include water diffusivity and sediment-water or cap-water partition coefficient. The water diffusivity of most compounds varies less than a factor of two from 1×10^{-5} cm²/sec. Higher molecular weight compounds such as PAHs tend to have a water diffusivity of the order of 5×10^{-6} cm²/sec. The water diffusivity can be estimated using the Wilke-Chang method (Bird, Stewart, and Lightfoot 1960). Compilations of diffusivities are also available (Thibodeaux 1996; Montgomery and Welkom 1990).

The preferred means of determining the partition coefficient is through experimental measurement of sediment and pore water concentration in the sediment or cap. In this manner, any sorption of contaminant onto suspended particulate or colloidal matter is implicitly incorporated. If such measurements are unavailable, it is possible to predict values of the partition coefficient, at least for hydrophobic organic compounds, using Equation B8. K_{oc} values are tabulated (e.g., Montgomery and Welkom 1990) or may be estimated from solubility or the octanol-water partition coefficient using the methods in Lyman, Reehl, and Rosenblatt (1990). For other contaminants, including metals, little predictive guidance exists.

It should be emphasized that the pore water concentration, C_0 , appearing in the models is not the truly dissolved concentration but that corrected for the amount sorbed on the colloidal matter. Note that Equation B8 suggests that the apparent partition coefficient approaches the constant, f_{oc}/ρ_{oc} as $K_{oc} \rightarrow \infty$. That is, the apparent partition coefficient is no longer a function of the hydrophobicity of the contaminant when the product $\rho_{oc}K_{oc} \gg 1$. For example, the apparent partitioning of pyrene, with a $K_{oc} \sim 10^5$ L/kg and any compound more hydrophobic, is dominated by pore water organic matter at concentrations greater than about 10 mg/L.

Physical characteristics

The long-term average water flushing rate should be measured onsite to evaluate water-side mass transfer resistances. Cap material properties are dependent on the specific materials available and should be measured using standard analytical methods.

Mass transfer coefficients

A turbulent mass transfer correlation (Thibodeaux 1996) can be used to estimate the value of K_{bl} in the water above the cap:

$$Sh = 0.036 Re^{0.8} Sc^{1/3} \quad (B37)$$

where

$$Sh = \text{Sherwood number} = \frac{K_{bl} \cdot x}{D_w}$$

$$Re = \text{Reynolds number} = \frac{x \cdot u}{\nu}$$

$$Sc = \text{Schmidt number} = \frac{\nu}{D_w}$$

ν = kinematic viscosity of water, 0.01 cm²/sec at 20 °C

u = benthic boundary layer water velocity, cm/s

x = length scale for the contaminated region - here $x = \sqrt{A_s}$ is taken where A_s is area of contaminated region, cm

As indicated previously, however, the benthic boundary layer mass transfer coefficient is rarely significant in the estimation of contaminant flux through the cap.

Transport by bioturbation has often been quantified by an effective diffusion coefficient based on particle reworking rates. A bioturbation mass transfer coefficient can then be estimated from the following relation assuming linear partitioning between the sediment and water in the bioturbation layer

$$K_{bio} = \frac{D_{bio} \rho_b K_d \eta}{L_{bio}} \quad (B38)$$

where η is a desorption efficiency of the chemical once the particle carrying it has been reworked to the sediment-water interface. η would tend to be small for more hydrophobic compounds that tend to desorb slowly at the surface and large for compounds that are more soluble. In the absence of experimental

information to the contrary, η is assumed to be 1. The biodiffusion coefficient and the depth of bioturbation are important factors in the determination of the required cap thickness, and thus the best possible estimates should be used. The ranges for D_{bio} and L_{bio} are quite large, and an extensive tabulation is presented by Matisoff (1982). An examination of these data suggests that a depth of bioturbation of 2 to 10 cm is typical and that biodiffusion coefficients are generally in the range of 0.3 to 30 cm²/year. As indicated previously, however, the contaminant flux is controlled by transport through the cap and is essentially insensitive to the bioturbation mass transfer coefficient. The contaminant concentration in the bioturbated layer, however, is heavily dependent upon the biodiffusion coefficient.

Evaporation mass transfer coefficient

The overall evaporation mass transfer coefficient is taken as equal to the water-side mass transfer coefficient. This is generally valid for volatile organic compounds but less true for many PAHs, which tend to exhibit significant air-side mass transfer resistances. A water-side mass transfer coefficient for evaporative losses is given by Lunny, Springer, and Thibodeaux (1985) as

$$K_e = 19.6 U_x^{2.23} D_w^{2/3} \quad (\text{B39})$$

where U_x is the wind speed at 10 m (miles/hour), D_w has units of square centimeters/second, and K_e has units of centimeters/hour. Lyman, Reehl, and Rosenblatt (1990) provide information on air-side coefficients that may be important for some compounds, notably low-volatility PAH compounds.

Example

Several design bases are possible for specifying the physico-chemical containment afforded by a cap. There are at least five quantities that may be of interest to the cap designer and for which models were presented here. These are the breakthrough time, the pollutant release rate (as a source term input to other fate and effects models), concentrations at the sediment-water interface or in the overlying water column, and the time to approach steady state. The two physico-chemical properties of the cap material that have the largest effect on the efficacy of the cap are the organic carbon content and the cap thickness. Each of these calculations will be illustrated given a cap thickness. In general, the process would be applied iteratively using a guessed cap thickness until the desired breakthrough times, fluxes, etc, are achieved.

The selected example considers a sediment contaminated with a moderately hydrophobic polyaromatic hydrocarbon, pyrene. The contaminant is initially present in the upper 35 cm of sediment at a level of 100 mg/kg. A cap of initial thickness of 50 cm is placed over this sediment. Both the cap and the sediment contain 1-percent organic carbon. Consolidation of the cap after placement

reduces the cap thickness to 45 cm. The sediment also consolidates 5 cm as a result of cap placement. Bioturbation is expected to influence the upper 10 cm of sediment or cap. These and other problem parameters are collected in Table B1. The calculation procedure is detailed below.

Table B1 Physico-Chemical Properties of Site Parameters for Example		
<u>Cap Properties</u>		
Initial cap thickness	(L_o)	50 cm
Consolidation distance within cap	(ΔL_{cap})	5 cm
Consolidation distance of underlying sediment	(ΔL_{sed})	5 cm
Organic carbon content	(f_{oc})	0.01
Porosity	(e)	0.5
Bulk density	(ρ_b)	1.25 g/cm ³
Colloid concentration	(C_c)	10 mg/L
Effective cap thickness	(L_{eff})	35 cm
<u>Pyrene Properties</u>		
Solubility	(s)	150 µg/L
Diffusivity in water	(D_w)	5×10^{-5} cm ² /sec
Organic carbon partition coeff.	(K_{oc})	10 ⁵ L/kg
Mass transfer coeff. at air-water interface	(K_{a_e})	7 cm/hr
Mass transfer coeff. at cap-water interface	(K_{b_i})	1 cm/hr
<u>Site Properties</u>		
Bioturbation depth	(L_{bio})	10 cm
Biodiffusion coefficient	(D_{bio})	10 cm ² /year
Seepage velocity in sediment (assume outflow)	(U)	10 cm/year
Pyrene sediment loading	(ω_s)	100 mg/kg
Pore water concentration	(C_{pw})	200 µg/L
Area of contaminated sediment	(A_s)	10 ⁴ m ²
Evaporative area	(A_e)	10 ⁴ m ²
Benthic boundary layer velocity	(u)	10 cm/sec
Basin flushing rate	(Q)	1.7×10^{13} cm ³ /day
Thickness of contaminated region		35 cm (used in numerical model only)

Estimation of effective cap thickness

The initial cap thickness is reduced by bioturbation (10 cm), consolidation of the cap (5 cm), and penetration of pore water expressed by the consolidation of the underlying sediment. Although the sediment consolidates a distance of 5 cm, causing movement of pore water 10 cm into the cap (cap porosity of 50 percent), the contaminant migration is retarded by sorption onto the organic carbon in the cap. After estimation of the retardation factor associated with sorption onto the cap materials, it is estimated that the chemical penetration into the cap as a result of sediment consolidation is only about 80 µm. Thus the effective cap thickness is

$$\begin{aligned}
 L_{eff} &= 50 \text{ cm} \\
 &\quad - 10 \text{ cm (bioturbation)} \\
 &\quad - 5 \text{ cm (consolidation of cap)} \\
 &\quad - 80 \text{ } \mu\text{m (sediment consolidation)} \\
 &\approx 35 \text{ cm}
 \end{aligned}$$

This calculation included an estimate of the partition coefficient and retardation factor for the migration of pyrene through the cap. The partition coefficient and pore water concentrations were estimated based on the sediment loading (Equation B5 and the second of Equations B8). The maximum truly dissolved concentration in the pore water is given by the solubility of pyrene in water (150 $\mu\text{g/L}$) meaning that in the 1-percent organic carbon sediment with a pyrene $K_{oc} = 10^5 \text{ L/kg}$, the sediment loading must be less than 150 mg/kg for this to be true. At sediment loadings above 150 mg/kg, the pore water concentration in the contaminated region must be estimated by Equation B7.

Estimation of long-term losses

The simple analytical models presented in this appendix assume that the zone of contamination is infinitely large and is not depleted by losses through the cap. Since a groundwater seepage velocity is specified in this example, such an assumption means that ultimately the flux through the cap is given by the seepage velocity times the pore water concentration in the sediment beneath the cap or $20 \text{ mg}\cdot\text{m}^{-2}\cdot\text{year}^{-1}$. In the absence of any seepage through the cap, the steady-state diffusive flux would apply, $3.6 \text{ mg}\cdot\text{m}^{-2}\cdot\text{year}^{-1}$. Both estimates overestimate the actual long-term flux, however, in that they assume that the sediment beneath the cap exhibits a constant concentration. A numerical calculation of the flux is provided later to illustrate the degree of conservatism by these calculations, even if no chemical degradation of the pyrene occurs.

Evaluation of diffusion only mechanism

Using Equations B25 and B26, the breakthrough and steady-state times are given by 669 and 4,600 years, respectively. These estimates assume only diffusion is applicable and that the concentration is again constant.

At steady-state conditions assuming constant sediment concentrations, the diffusion model also allows estimation of pore and overlying water concentrations. Although the predominant mass transfer resistance is the undisturbed cap, the bioturbation zone and the benthic boundary layer resistance influence the concentrations observed in the bioturbation layer, at the sediment-water interface, and in the overlying water.

Example Calculation of Contaminant Flux-Advection/Diffusion Mechanism

In this example, flux predictions by the analytical model of capped sediment are compared with an uncapped case and a numerical model that recognizes the depletion in the underlying sediment due to transport to the overlying water. The numerical model is capable of describing arbitrary and heterogeneous initial conditions and depletion within the sediment. The model is written in FORTRAN and employs IMSL routines for some calculations. Both the

analytical model in the form of a Mathcad spreadsheet and the numerical model are available from the author

Danny Reible, Director
Hazardous Substance Research Center/S&SW
Louisiana State University
Baton Rouge, LA 70803
Ph: 504/388-3070, Fax: 504/388-1476, e-mail: reible@che.lsu.edu

The model predictions for flux are shown in Figure B2.

Comparison of Uncapped and Analytical and Numerical Capped Model Predictions

The first case is for a contaminated system with no cap. The result is presented as the solid line in Figure B2. The flux starts out at a high value (effectively infinite at time of first exposure of the contaminated sediment) and decreases with time.

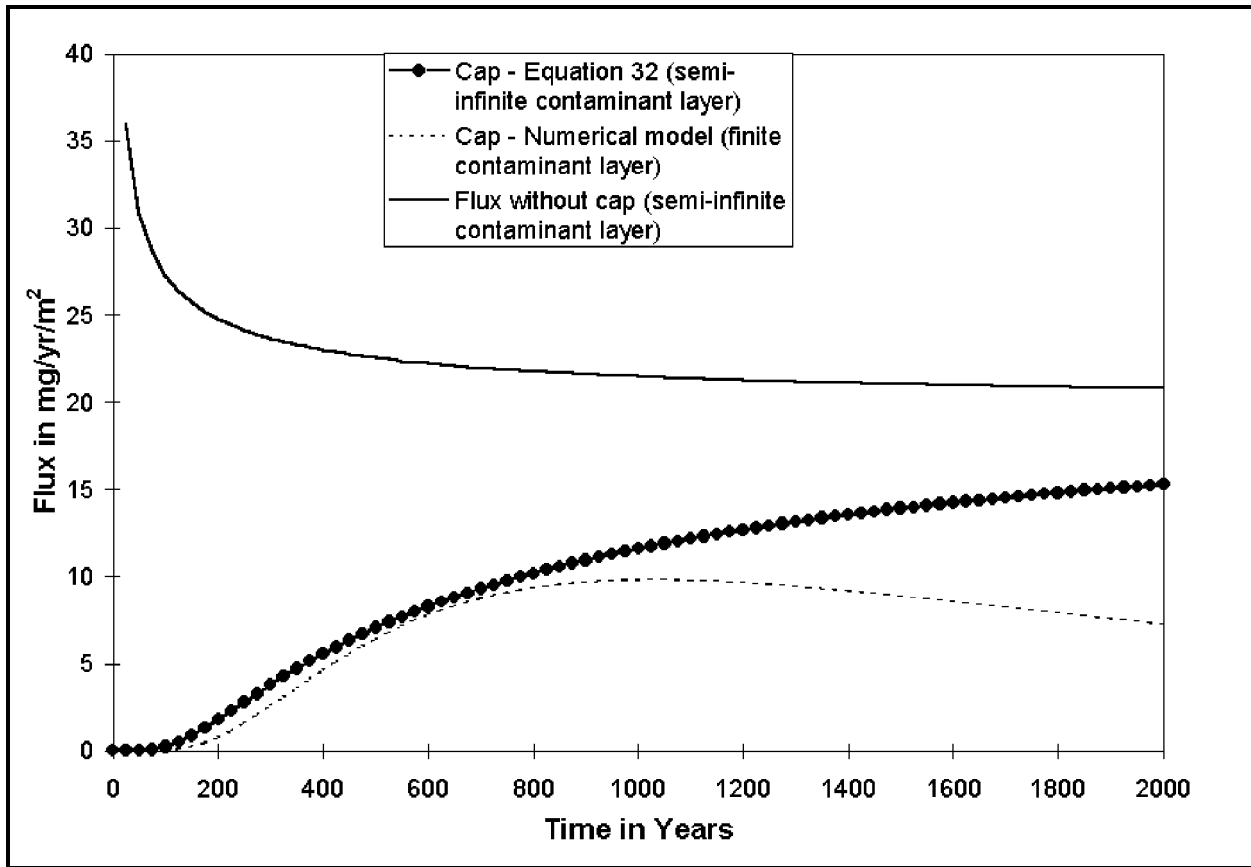

Figure B2. Example calculations of contaminant flux through cap

Example - Mathcad Spreadsheet

Note - All numerical values employed in this simulation are for illustration only. Although some of these values may represent typical field conditions, they do not indicate the range of values encountered in the field and do not therefore allow the drawing of general conclusions as to the effectiveness of capping

Estimation of effective cap thickness

$L_0 := 50 \cdot \text{cm}$	Initial thickness of cap
$L_{\text{bio}} := 10 \cdot \text{cm}$	Thickness effectively mixed by bioturbation
$\Delta L_{\text{cap}} := 5 \cdot \text{cm}$	Consolidation distance within the cap
$\Delta L_{\text{sed}} := 5 \cdot \text{cm}$	Consolidation distance of underlying sediment
$\varepsilon := 0.5$	Void fraction in cap
$\rho_b := 0.5 \cdot 2.5 \cdot \frac{\text{gm}}{\text{cm}^3}$	Bulk density of sediment
$\Delta L_{\text{sed.pw}} := \frac{\Delta L_{\text{sed}}}{\varepsilon}$	Pore water penetration distance in cap
	$\Delta L_{\text{sed.pw}} = 0.1 \cdot \text{m}$

Estimation of sorption characteristics in cap and retardation factor

$K_{\text{oc}} := 10^5 \cdot \frac{\text{L}}{\text{kg}}$	Organic carbon based partition coefficient	$L := 1000 \cdot \text{cm}^3$
	Compound assumed: Pyrene	$\mu\text{g} := 10^{-6} \cdot \text{gm}$
$\rho_{\text{oc}} := 10 \cdot \frac{\text{mg}}{\text{L}}$	Dissolved organic carbon concentration in pore water	
$f_{\text{oc}} := 0.01$	Fraction organic carbon in sediment	
$S := 0.150 \cdot \frac{\text{mg}}{\text{L}}$	Solubility of pyrene in water	
$\omega_{\text{crit}} := K_{\text{oc}} \cdot f_{\text{oc}} \cdot S$	Critical sediment loading	$\omega_{\text{crit}} = 150 \cdot \frac{\text{mg}}{\text{kg}}$

$$K_d := \frac{K_{oc} \cdot f_{oc}}{1 + \rho_{oc} \cdot K_{oc}}$$

Observed partition coefficient between sediment and water
assumes K_{oc} governs partitioning to dissolved org. carbon

$$K_d = 500 \frac{L}{kg} \quad \text{Also assumes sediment } < \omega_{crit}$$

$$R_f := \epsilon + \rho_b \cdot K_d$$

Retardation factor due to sorption onto solid

$$R_f = 625.5$$

$$\Delta L_{sed.A} := \frac{\Delta L_{sed}}{R_f}$$

Penetration distance of chemical into cap due to
consolidation of sediment

$$\Delta L_{sed.A} = 7.994 \cdot 10^{-5} \cdot m \quad \text{Typically negligible for sorbing caps}$$

$$L_{eff} := L_0 - L_{bio} - \Delta L_{cap} - \Delta L_{sed.A}$$

Effective cap thickness

$$L_{eff} = 0.35 \cdot m$$

Estimation of long-term losses

a. Determination of Peclet number defining the relative importance of advection to diffusion

$$U := 10 \frac{cm}{yr}$$

Seepage velocity in sediment- assume outflow

$$D_w := 5 \cdot 10^{-6} \frac{cm^2}{sec}$$

Molecular diffusion coefficient in water

$$D_{eff} := D_w \cdot \epsilon^{\frac{4}{3}}$$

Millington and Quirk model for effective diffusivity

$$D_{eff} = 1.984 \cdot 10^{-6} \frac{cm^2}{sec}$$

$$Pe := \frac{U \cdot L_{eff}}{D_{eff}}$$

Peclet number

$$Pe = 5.588 \quad \text{Advection/diffusion both important}$$

Chemical concentration level - assumed deep layer of sediment contaminated to 100 mg/kg

$$W_s := 100 \frac{mg}{kg}$$

$$C_0 := \frac{W_s}{K_d}$$

$$C_0 = 200 \frac{\mu g}{L}$$

Note - $W_s < 150$ mg/kg - below critical loading as assumed

Advective flux

$$F_{adv} := U \cdot C_0$$

Advective flux - since a deep layer of contaminated sediment is assumed, the flux at long time is given by this for a seepage outflow

$$F_{adv} = 20 \frac{\text{mg}}{\text{m}^2 \cdot \text{yr}}$$

Diffusive flux-hypothetical unless $Pe \ll 1$ and depletion of material in sediment can be neglected

$$F_{diff} := \frac{D_{eff}}{L_{eff}} \cdot C_0$$

Steady-state diffusive flux (assuming no advection and no depletion of contaminants by diffusion through cap)

$$F_{diff} = 3.579 \frac{\text{mg}}{\text{m}^2 \cdot \text{yr}}$$

Transient behavior- assuming diffusion only

$$\tau_b := \frac{0.54 L_{eff}^2 \cdot R_f}{D_{eff} \pi^2}$$

Breakthrough time assuming no depletion of contaminant in sediment

$$\tau_b = 669.218 \text{ yr}$$

$$\tau_{ss} := \frac{3.69 L_{eff}^2 \cdot R_f}{D_{eff} \pi^2}$$

Time required to reach hypothetical steady state flux (F_{diff}) assuming no depletion of contaminants in sediment

$$\tau_{ss} = 4572.99 \text{ yr}$$

Estimation of overall mass transfer coefficient and concentrations in water and at the sediment-water interface assuming quasi-steady diffusion

$$K_{cap} := \frac{D_{eff}}{L_{eff}}$$

Effective mass transfer coefficient in cap—assuming quasi-steady diffusion

$$K_{cap} = 1.789 \frac{\text{cm}}{\text{yr}}$$

$$D_{bio} := 10 \frac{\text{cm}^2}{\text{yr}}$$

Effective bioturbation diffusion coefficient

$$\eta := 1$$

Fraction of contaminants released at surface between arrival at surface and reburial by bioturbation

$$K_{\text{bio}} := \frac{\eta \cdot D_{\text{bio}} \cdot R_f}{L_{\text{bio}}}$$

Effective bioturbation mass transfer coefficient for particle movement at effective diffusion coefficient D_{bio}

$$K_{\text{bio}} = 625.5 \frac{\text{cm}}{\text{yr}}$$

$$K_{\text{bl}} := 1 \frac{\text{cm}}{\text{hr}}$$

Effective mass transfer coefficient at sediment (cap) - water interface

$$K_e := 7 \frac{\text{cm}}{\text{hr}}$$

Effective mass transfer coefficient at air-water interface

$$Q := 1.7 \cdot 10^{13} \frac{\text{cm}^3}{\text{day}}$$

Effective flushing rate of overlying water

$$A_s := 10^4 \cdot \text{m}^2$$

Area of contaminated sediment

$$A_e := 10^4 \cdot \text{m}^2$$

Evaporative area

$$K_{\text{ov}} := \left(\frac{1}{K_{\text{cap}}} + \frac{1}{K_{\text{bio}}} + \frac{1}{K_{\text{bl}}} + \frac{A_s}{K_e \cdot A_e + Q} \right)^{-1}$$

Effective overall mass transfer coefficient

$$K_{\text{ov}} = 1.784 \frac{\text{cm}}{\text{yr}}$$

Typically same as cap coefficient

$$C_w := \frac{K_{\text{ov}} \cdot A_s}{K_e \cdot A_e + Q} \cdot C_0$$

Water concentration assuming steady diffusion through cap and only evaporation and flushing losses from water

$$C_w = 5.741 \cdot 10^{-6} \frac{\mu\text{g}}{\text{L}}$$

$$C_{\text{sw}} := \frac{K_{\text{ov}} \cdot C_0}{K_{\text{bl}}}$$

Concentration in porewater at sediment (cap)- water interface
This should indicate exposure of benthic organisms

$$C_{\text{sw}} = 0.041 \frac{\mu\text{g}}{\text{L}}$$

Flux via full - advection diffusion model

$$\alpha := L_{\text{eff}}$$

Set dispersivity to upper bound of cap thickness

$$D := D_{\text{eff}} + \alpha \cdot U$$

Dispersion coefficient sum of diffusion and advective dispersion

$$D = 1.307 \cdot 10^{-5} \frac{\text{cm}^2}{\text{sec}}$$

Concentration model - semi-infinite cap with concentration in underlying sediment constant

$$C(L, t) := \left[\left[1 - \operatorname{erf} \left(\frac{R_f L - U \cdot t}{2 \cdot \sqrt{R_f D \cdot t}} \right) + \exp \left(\frac{U \cdot L}{D} \right) \cdot \left(1 - \operatorname{erf} \left(\frac{R_f L + U \cdot t}{2 \cdot \sqrt{R_f D \cdot t}} \right) \right) \right] \cdot \frac{C_0}{2} \right]$$

Concentration gradient near surface → needed for estimation of diffusion flux

$$DCDZ(L, t) := \frac{1}{2} \cdot \left[\frac{-1}{\sqrt{\pi}} \cdot \exp \left[\frac{-1}{4} \cdot \frac{(R_f L - U \cdot t)^2}{[R_f (D \cdot t)]} \right] \cdot \frac{\sqrt{R_f}}{(\sqrt{D} \cdot \sqrt{t})} + \frac{U}{D} \cdot \exp \left(\frac{U \cdot L}{D} \right) \cdot \left[1 - \operatorname{erf} \left[\frac{1}{2} \cdot \frac{(R_f L + U \cdot t)}{[\sqrt{R_f} \cdot (\sqrt{D} \cdot \sqrt{t})]} \right] \right] \right] \cdot C_0$$

$$+ \frac{-\exp \left(\frac{U \cdot L}{D} \right)}{\sqrt{\pi}} \cdot \exp \left[\frac{-1}{4} \cdot \frac{(R_f L + U \cdot t)^2}{[R_f (D \cdot t)]} \right] \cdot \frac{\sqrt{R_f}}{(\sqrt{D} \cdot \sqrt{t})}$$

$$t_{\text{int}} := 100 \cdot \text{yr}$$

t_{int} = time interval desired

$$j := 1..20$$

j = number of values of time

$$F_{\text{adv}, j} := U \cdot C(L_{\text{eff}}, j \cdot t_{\text{int}})$$

Advective component of flux

$$F_{\text{diff}, j} := - (D_{\text{eff}} \cdot DCDZ(L_{\text{eff}}, j \cdot t_{\text{int}}))$$

Diffusive component of flux

$$F_{\text{adv.diff}, j} := F_{\text{adv}, j} + F_{\text{diff}, j}$$

Total flux from cap-water interface

Comparison to uncapped flux (This approach recognizes that the same equation is applicable if water-side mass transfer resistances are always negligible)

$$F_{\text{uncapped}, j} := U \cdot C(0 \cdot \text{cm}, j \cdot t_{\text{int}}) - D_{\text{eff}} \cdot DCDZ(0 \cdot \text{cm}, j \cdot t_{\text{int}})$$

Note that both analytical models (capped and uncapped) assume that the contaminant layer is of infinite depth. At long times when this assumption is poor, a numerical simulation should be used in either case as shown in Figure B2.

--

Summary of Results—also shown in Figure B2 with numerical model results assuming a 35-cm depth of contamination

Time $j \cdot t_{int}$ yr	Conc. at cap water interface $C(L_{eff} \cdot j \cdot t_{int})$ $\left(\frac{\mu\text{g}}{\text{L}}\right)$	Fluxes via advection, diffusion and combined			
		F_{adv_j} $\left(\frac{\text{mg}}{\text{m}^2 \cdot \text{yr}}\right)$	F_{diff_j} $\left(\frac{\text{mg}}{\text{m}^2 \cdot \text{yr}}\right)$	$F_{adv.diff_j}$ $\left(\frac{\text{mg}}{\text{m}^2 \cdot \text{yr}}\right)$	$F_{uncapped_j}$ $\left(\frac{\text{mg}}{\text{m}^2 \cdot \text{yr}}\right)$
100	0.701	0.07	0.122	0.192	27.266
200	9.399	0.94	0.839	1.779	24.753
300	23.526	2.353	1.426	3.779	23.65
400	38.032	3.803	1.75	5.554	23
500	51.306	5.131	1.905	7.036	22.56
600	63.054	6.305	1.962	8.268	22.238
700	73.369	7.337	1.964	9.301	21.991
800	82.435	8.244	1.934	10.178	21.794
900	90.439	9.044	1.887	10.931	21.631
1000	97.544	9.754	1.831	11.585	21.496
1100	103.888	10.389	1.769	12.158	21.38
1200	109.584	10.958	1.707	12.665	21.28
1300	114.724	11.472	1.644	13.116	21.193
1400	119.387	11.939	1.583	13.521	21.116
1500	123.634	12.363	1.523	13.887	21.047
1600	127.519	12.752	1.466	14.218	20.986
1700	131.086	13.109	1.411	14.519	20.931
1800	134.373	13.437	1.358	14.796	20.88
1900	137.411	13.741	1.308	15.049	20.835
2000	140.227	14.023	1.26	15.283	20.793

Capped Flux < 1% Uncapped Flux for more than 100 years

Capped Flux approximately 1/2 uncapped flux after 1,000 years (Maximum flux if initial contaminant thickness is 35 cm) from numerical model)

In the next case a cap has been placed and the flux through the cap is estimated subject to the previously discussed assumptions of constant concentration in the underlying sediment. This system is described by Equation B32. The result is presented by the broken line in Figure B2. The flux is initially zero until cap breakthrough, and the flux then slowly increases with time. After several thousand years in this example, the flux with and without the cap approaches the constant value of $20 \text{ mg}\cdot\text{m}^{-2}\cdot\text{year}^{-1}$. Again, both models approach the same value because the contaminated region is assumed infinitely thick and advection ultimately controls the flux.

In the final case, the conditions are identical to the capped case above, but mass transfer is recognized to cause depletion of the contaminant beneath the cap and the actual thickness (and therefore finite mass) of the contaminated region is explicitly considered. The thickness of the contaminated region is assumed identical to the effective thickness of the cap, 35 cm. No degradation is assumed, consistent with the previous examples. The solution by the numerical model is given as the dotted line on Figure B2. Of the three models, this is the only one that satisfies the material balance in that the loss to the overlying water is reflected in reductions in mass in the contaminants in the sediment.

The plot of flux with time for an uncapped system shows a high initial flux owing to a large concentration gradient at the surface initially. With depletion in the near-surface sediment, the flux asymptotically approaches a limit given by the advective flux from the deep-sediment concentrations. With a cap, the contaminant takes some time to seep through the clean capped region. Hence there is an initial time period when there is essentially no contaminant flux. Since there is an assumption of constant contaminant concentration at the base of the cap, the flux asymptotically approaches a maximum that would ultimately equal the uncapped flux. The realistic model that accurately accounts for contaminant depletion in the sediment shows a flux that never reaches as high as the flux from either of the two preceding models, and it steadily decreases at long time.

Note that in either capped case, the total mass released to the water column is significantly reduced for any period of time. The total mass released is the integral under the flux curves.

In this example it was assumed that the bioturbated region offers no resistance to the transport of contaminants. A model explicitly accounting for the bioturbated region could also be developed. Similarly, the effect of cap thickness and contaminated layer thickness or inhomogeneity on the long-term flux profile can be studied using the numerical model. This is not possible using the conservative analytical model Equation B32.

Acknowledgments

This appendix was prepared with the partial support of the U.S. Environmental Protection Agency through the Hazardous Substance Research

Center/South and Southwest and through cooperative agreement CR 823029-01-0 from the National Risk Management and Research Laboratory, Cincinnati, OH.

References

- Bear, J. (1979). *Hydraulics of groundwater*. McGraw-Hill, New York.
- Bird, R. B., Stewart, W. E., and Lightfoot, E. N. (1960). *Transport phenomena*. John Wiley & Sons, New York.
- Carslaw, H. S., and Jaeger, J. C. (1959). *Conduction of heat in solids*. 2d ed., Oxford University Press, Oxford, England.
- Cleary, R. W., and Adrian, D. D. (1973). "Analytical solution of the convection-dispersive equation for cation adsorption in soils," *Soil Sci Soc. America Proc.* 37, 197-199.
- IMSL. (1994). Visual Numerics, Inc., Houston, TX.
- Lunney, P. D., Springer, C., and Thibodeaux, L. J. (1985). "Liquid phase mass transfer coefficients for surface impoundments," *Environmental Progress* 109 (4), 203-211.
- Lyman, W. J., Reehl, W. F., and Rosenblatt, D. H. (1990). *Handbook of chemical property estimation methods: Environmental behavior of organic chemicals*, American Chemical Society: Washington DC.
- Matisoff, G. (1982). "Mathematical models of bioturbation," *Animal-sediment relations*. P. L. McCall and M. J. Tevesz, ed., Plenum Press, New York, 289-331.
- Millington, R. J., and Quirk, J. M. (1961). "Permeability of porous solids," *Trans. of Faraday Soc.* 57, 1200-1207.
- Montgomery, J. H., and Welkom, L. M. (1990). *Groundwater chemicals desk reference*. Vol 1. Lewis Publishers, Inc., Chelsea, MI.
- Palermo, M. R., Maynard, S., Miller, J., and Reible, D. D. (1996). "Guidance for in-situ subaqueous capping of contaminated sediments," Environmental Protection Agency, EPA 905-B96-004, Great Lakes National Program Office, Chicago, IL.
- Stark, T. D. (1991). "Program documentation and user's guide: PCDDF89, primary consolidation and dewatering of dredged fill," Instruction Report D-91-1, U.S. Army Engineer Waterways Experiment Station, Vicksburg, MS.

- Thibodeaux, L. J. (1996). *Environmental chemodynamics: Environmental movement of chemicals in air, water and soil*. 2d ed., Wiley & Sons, New York.
- Thibodeaux, L. J., and Bosworth, W. S. (1990). "A theoretical evaluation of the effectiveness of capping PCB contaminated New Bedford Harbor Bed Sediment," Final Report, Hazardous Waste Research Center, Louisiana State University, Baton Rouge, LA.
- Thoma, G. J., Reible, D. D., Valsaraj, K. T., and Thibodeaux, L. J. (1993). "Efficiency of capping contaminated sediments in situ: 2. Mathematics of diffusion-adsorption in the capping layer," *Environmental Science and Technology* 27, 12, 2412-2419.

Appendix C

Capping Effectiveness Tests

Introduction

Results of laboratory tests conducted with samples of the contaminated sediments to be capped and the proposed capping sediments should yield sediment-specific and capping-material-specific values of diffusion coefficients, partitioning coefficients, and other parameters needed to model long-term cap effectiveness. Model predictions of long-term effectiveness using the laboratory-derived parameters should be more reliable than predictions based on so-called default parameters. At present, there are several tests that have been applied for this purpose.

Louisiana State University has conducted laboratory tests to assess diffusion rates for specific contaminated sediments to be capped and materials proposed for caps. A capping simulator cell was used in which a cap material layer is placed over a contaminated sediment, and flux due to diffusion is measured in water that was allowed to flow over the cap surface. Initial tests measured flux of 2,4,6-trichlorophenol (TCP) through various cap materials. These tests showed that the breakthrough time and time to steady state were directly dependent on the partitioning coefficient and that cap porosity and thickness were the dominant parameters at steady state (Wang et al. 1991).¹

Environment Canada has performed tank tests on sediments from Lake Ontario to qualitatively investigate the interaction of capping sand and compressible sediments. The tests were carried out in 3.6- by 3.6- by 3.7-m observation tanks in which the compressible sediments were placed and allowed to consolidate; sand was released through the water column onto the sediment surface. In the initial tests, physical layering and consolidation behavior were observed. Additional tests are planned in which migration of contaminants due to consolidation-induced advective flow will be evaluated (Zeman 1993).

¹ References cited in this appendix are listed in the References at the end of the main text.

The U.S. Army Corps of Engineers (USACE) has also developed leach tests to assess the quality of water moving through a contaminated sediment layer into groundwater in a confined disposal facility environment (Myers and Brannon 1991). This test has been applied to similarly assess the quality of water potentially moving upward into a cap due to advective forces.¹

USACE Small-Scale Column Test

The USACE developed a first-generation capping effectiveness test in the mid-1980s as part of the initial examination of capping as a dredged material disposal alternative. The test was developed based on the work of Brannon et al. (1985, 1986), Gunnison et al. (1987), Environmental Laboratory (1987), and Sturgis and Gunnison (1988).

The tests basically involve layering contaminated and capping sediments in columns (Figure C1) and experimentally determining the cap sediment thickness necessary to chemically isolate a contaminated sediment by monitoring the changes in dissolved oxygen, ammonium-nitrate, orthophosphate-phosphorous, or other tracers in the overlying water column.

The thickness of granular cap material for chemical isolation determined using this procedure is on the order of 1-ft for most sediments tested to date. However, this column testing procedure does not account for potential advection nor long-term flux of contaminants due to diffusion. The USACE Small-Scale Column Test is therefore only applicable for evaluation of capping thicknesses for isolation of nutrient-rich sediments.

The procedure for conducting the small-scale column test is presented below.

Chemical tracers

The test uses dissolved oxygen (DO) depletion, ammonium-nitrogen, and orthophosphate phosphorus as tracers because they are easy and inexpensive to measure. A cap thickness that is effective in preventing the movement of these inorganic constituents will also be effective in preventing the movement of organic contaminants that are more strongly bound to sediment (e.g., polynuclear aromatic hydrocarbons (PAHs), petroleum hydrocarbons, and polychlorinated biphenyls (PCBs)). The behavior of soluble-reduced inorganic species (e.g., arsenic) is also similar to the tracers.

Dissolved oxygen depletion in the water column is normally not a problem in an open-water disposal environment, due to mixing and reaeration of the water

¹ Personal Communication, 1995, Tommy E. Myers, U.S. Army Engineer Waterways Experiment Station, Vicksburg, MS.

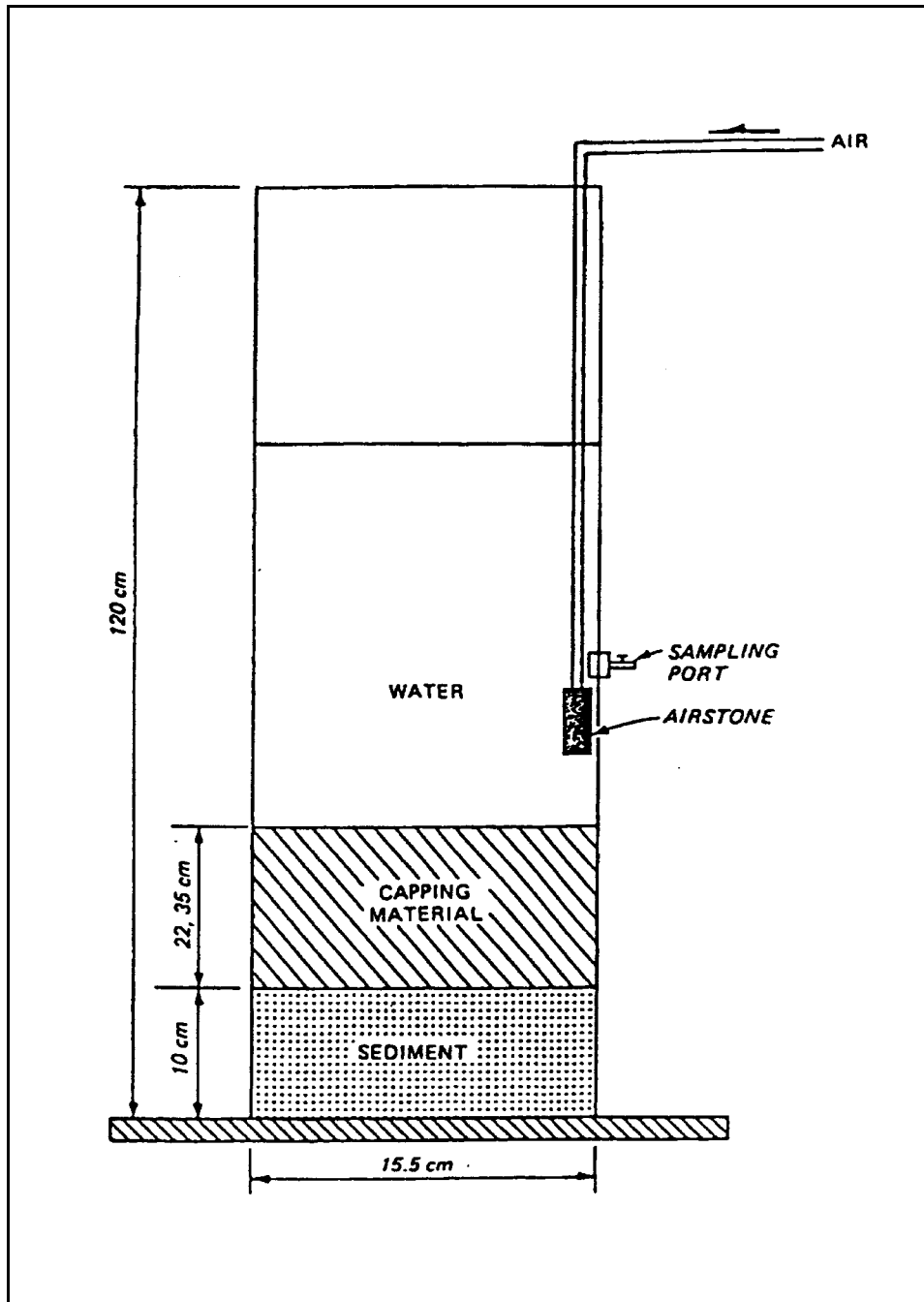

Figure C1. Small-scale column test unit for capping effectiveness (Sturgis and Gunnison 1988)

column. However, DO depletion can be used as a tracer for determining the effectiveness of a cap in isolating an underlying contaminated dredged material having an oxygen demand exceeding that of the capping material. A cap thickness that is effective in preventing or reducing the diffusion of DO into the contaminated sediment will also prevent or reduce the diffusion of DO-demanding species from the contaminated sediment into the overlying water column. Once

an effective cap thickness has been achieved, there will be no significant difference in oxygen-depletion rates between the contaminated sediment with cap material and the cap material alone.

A similar rationale is applicable for using ammonium-nitrogen and orthophosphate-phosphorus as tracers. These constituents are released only under anaerobic conditions. However, if the layer of cap material is thick enough to prevent the diffusing materials in the underlying contaminated dredged material from reaching the water column, the release rates from the capped contaminated sediment will be the same as from the cap material alone.

Because of the potential variation of chemical and biochemical properties in sediments, more than one tracer (ammonium-nitrogen, orthophosphate-phosphorus, and DO depletion) must be considered for each application (Brannon et al. 1985, 1986; Gunnison et al. 1987; Environmental Laboratory 1987). Frequently, the contaminated sediment and the proposed capping material are so different that a chemical property of the contaminated sediment is easily distinguishable from that same property of the cap material. However, when the cap material has chemical properties similar to the contaminated sediment, chemical differences are harder to distinguish. In such a case, if only one tracer is measured and negative results are obtained, a second series of tests is necessary.

Water analysis

The release rates of ammonium-nitrogen and orthophosphate-phosphorus must be determined in accordance with procedures recommended by Ballinger (1979). The depletion rate of DO is determined using either the azide modification of the Winkler method, as described in Standard Methods (American Public Health Association 1986), or a DO meter.

Sediment collection

Samples of contaminated sediment must be collected that are representative of sediment to be dredged. Samples of the proposed capping material must also be taken. To ensure that sediment samples are not diluted with large volumes of water, a clamshell dredge or similar device is used to sample both contaminated sediment and capping material. Representative subsamples of both materials are taken for initial bulk analysis and characterization. All sediments are to be placed into polyethylene-lined steel barrels, sealed, and stored at 4 °C until tested.

Sediment sampling and preparation

The capping effectiveness test is run using representative samples of the contaminated and capping sediments (see Chapter 3 of the main text). Sediment

samples are composited and mixed, using a motorized mixer (to ensure a homogenous sediment sample). Any unused sediment is returned to the containers, stored at 4 °C, and later discarded if there is no further need for the sediment.

Materials and equipment

The following items are required to conduct the laboratory test:

- a. Twelve to fifteen 22.6-L cylindrical plexiglass units, 120 cm in height and 15.5 cm in diameter attached to a 30-cm, 2-plexiglass base (Figure C1). The units should be fitted with a sampling port.
- b. Twelve plexiglass plungers, 80 cm in length with a wire hook attached at the top.
- c. Twelve pint-size bottles of mineral oil.
- d. Six aquarium pumps (two small-scale units per pump) or some other source of air supply.
- e. Twelve 1-cm-long air stones.
- f. Two plexiglass tubes, 130 cm in length, 7.28-cm inside diameter.
- g. Two large funnels, 40.8-cm top diameter, 6.60-cm outside diameter at the base.
- h. Tygon tubing, 3.02-mm inside diameter.

Test procedure

Step 1 - Add contaminated sediment to the units. The contaminated sediment is mixed, then placed in the bottom of the small-scale units to a depth of 10 cm (Figure C1). It is important to add the sediment carefully to avoid splashing on the sides of the units. Three of the units are reserved for capping material only as described in Step 2.

Step 2 - Add capping material. The capping material is mixed and then added in varying thicknesses (e.g., 10, 20, and 30 cm) to triplicate units containing the contaminated sediment (Figure C1). Three units with contaminated sediment receive no cap. An additional three units receive 10 cm each of capping material only. Units containing contaminated sediment alone and units with capping material alone serve as controls.

Step 3 - Water addition and unit aeration. For an estuarine or marine simulation, 10 L of artificial seawater is prepared using artificial sea salts to

achieve the salinity of the proposed disposal area. For a freshwater simulation, 10 L of either distilled or reverse osmosis water is used. The water is added as gently as possible to each small-scale unit and allowed to equilibrate for 3 days while being aerated. Aeration will ensure that the DO concentration in all units is at or near saturation (within ± 0.5 mg/L) at the start of the test.

After 3 days of aeration, the airstone is removed, and a plunger and mineral oil are added. The plunger is used for daily mixing to prevent the establishment of concentration gradients in the water column and to ensure a well-mixed column. Mineral oil is used to seal the surface of the water column from the atmosphere to allow the development of anaerobic conditions in the water column. The plunger is suspended between the sediment and the mineral oil. Mixing should be done in a manner that will not disturb the sediment in the bottom of the unit or breach the mineral oil on the surface of the water. After mixing, the plunger is left suspended in the water column.

Step 4 - DO measurements. Water samples are taken immediately after aeration for initial DO determination. Dissolved oxygen is measured daily until the DO is depleted in the water column of the uncapped contaminated sediment. The consequences of reducing the volume of the water column by taking DO samples is accounted for by multiplying the DO concentration (milligrams per liter) by the volume of water remaining in the unit after a given sampling. (See the Calculations section that follows.)

Step 5 - Water sampling and preservation. Water samples to be analyzed for ammonium-nitrogen and orthophosphate-phosphorus are taken immediately after the DO is depleted (Day 0) and subsequently on Days 15 and 30. These water samples should be cleared of particulate matter by passing through a 0.45- μ m membrane filter, preserved by acidification with concentrated hydrochloric acid (HCl) to pH 2, then stored at 4 °C. After the water column is sampled on Day 30, all water samples (Days 0, 15, and 30) are analyzed. Results from previous small-scale studies (Brannon et al. 1985, 1986; Gunnison et al. 1987; Environmental Laboratory 1987) have shown that complete anaerobic conditions are achieved in the water column within 30 days.

Data interpretation and analyses

The results from these laboratory tests indicate which of the thicknesses tested reduce overlying-water oxygen demand and transfer of ammonium-nitrogen and orthophosphate-phosphorus from the contaminated sediment to the level of the cap material alone.

Oxygen-depletion rates and ammonium-nitrogen and orthophosphate-phosphorus release rates are determined by performing linear regression analyses of mass uptake or release per unit area (milligrams per square meter) versus time. Means and standard deviations are determined for the triplicates, and t-tests are conducted to determine the statistical significance of differences between the

means. Rates plotted are the means and standard deviation of three replicates and represent values greater than the controls.

Calculations

The rates in this test are defined as milligrams per square meter per day. The total tracer concentration is determined by Equation C1:

$$T_t = P_d \cdot V_r \quad (1)$$

Then, the rate of release or mass uptake is evaluated using Equation 2,

$$R_a = T_t / A_u / \text{day} \quad (2)$$

where

T_t = tracer total concentration (mg) in the unit

P_d = tracer dissolved concentration (mg/ml) as determined by chemical analysis

V_r = volume of water (ml) remaining in the water column after a given sampling

R_a = rate of release or mass uptake, mg/m²/day

A_u = area (m) of the unit

day = number of days of study

The recommended thickness can then be evaluated by comparing the release rates (R_a) of tracers through the thicknesses tested to the release rates of tracers from the capping material alone. For a given thickness to be considered effective, its release rates must equal those from the capping material alone, or there should be no statistically significant difference.

Figure C2 is an example graph showing oxygen-depletion rates of the Black Rock Harbor sediment capped with sand plotted against cap thickness (centimeters). It is important to note that a series of cap thicknesses ranging from 2 to 26 cm were evaluated. The data points for Figure C2 are means and standard deviations of three replicates. Results show that a 22-cm cap of sand resulted in inhibition of oxygen demand equal to that of the sand cap itself, thus indicating a seal effective in isolating the overlying water column from oxygen demand due to Black Rock Harbor sediment. In this case, the recommended thickness for reducing oxygen demand on the overlying water by the contaminated sediment is 22 cm.

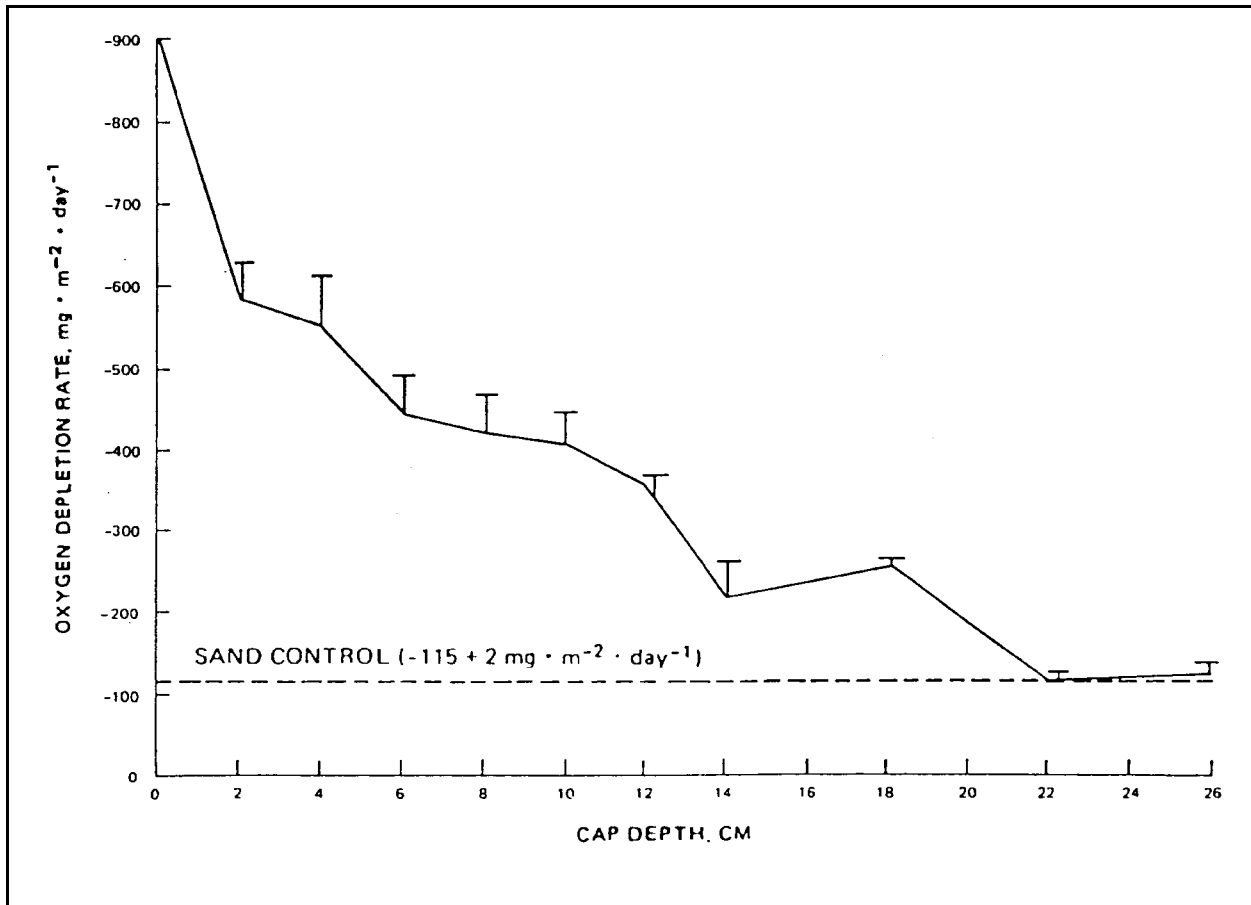

Figure C2. Typical results for effect of sand cap on oxygen command (Sturgis and Gunnison 1988)

Appendix D

Short-Term Fate (STFATE) of Dredged Material Model

Introduction

This appendix presents a summary description of the STFATE (Short-Term FATE of dredged material disposal in open water) model, a module of the Automated Dredging and Disposal Alternatives Management System (ADDAMS) (Schroeder and Palermo 1990). ADDAMS is an interactive computer-based design and analysis system in the field of dredged-material management. The general goal of the ADDAMS is to provide state-of-the-art computer-based tools that will increase the accuracy, reliability, and cost effectiveness of dredged-material management activities in a timely manner. The description of STFATE given in this appendix is a summary of the detailed information available in the users guide for the model provided in the inland testing manual for dredged material disposal (U.S. Environmental Protection Agency/U.S. Army Corps of Engineers (EPA/USACE), in preparation).

Theoretical Basis

The STFATE module is based on the earlier DIFID (DIsposal From an Instantaneous Discharge) model originally prepared by Koh and Chang (1973). STFATE has been refined several times to expand its predictive capability over a wider range of project conditions. The model is used for discrete discharges from barges and hoppers. The behavior of the material during disposal is assumed to be separated into three phases: convective descent, during which the disposal cloud falls under the influence of gravity and its initial momentum imparted by gravity; dynamic collapse, occurring when the descending cloud either impacts the bottom or arrives at a level of neutral buoyancy where descent is retarded and horizontal spreading dominates; and passive transport-dispersion, commencing when the material transport and spreading are determined more by ambient currents and turbulence than by the dynamics of the disposal operation. Figure D1 illustrates these phases. Details on the theoretical basis of the model are found in EPA/USACE (1991), EPA/USACE (in preparation), Johnson (1990), Koh and Chang (1973), and Brandsma and Divoky (1976).

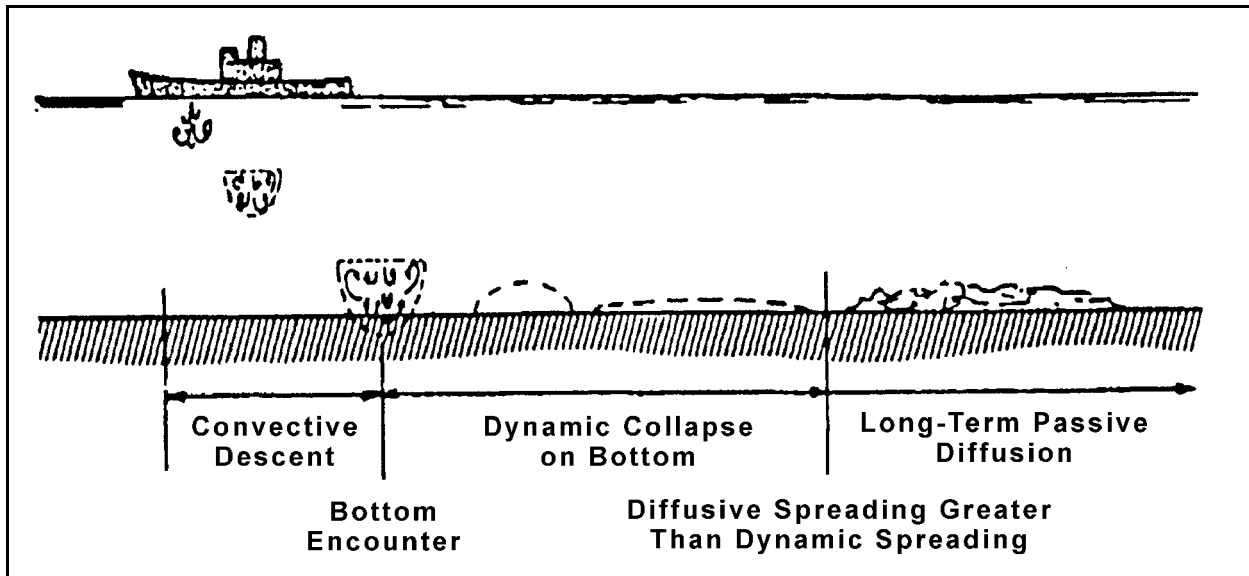

Figure D1. Illustration of placement processes

Model Input

Input data for the model are grouped into the following general areas:

- (a) description of the disposal site, (b) description of site velocities, (c) controls for input, execution, and output, (d) description of the dredged materials, (e) description of the disposal operation, and (f) model coefficients.

Ambient conditions include current velocity, density stratification, and water depths over a computational grid. The dredged material is assumed to consist of a number of solid fractions, a fluid component, and conservative dissolved contaminants. Each solid fraction has to have a volumetric concentration, a specific gravity, a settling velocity, a void ratio for bottom deposition, critical shear stress, and information on whether or not the fraction is cohesive and/or strippable. For initial-mixing calculations, information on initial concentration, background concentration, and water quality standards for the constituent to be modeled has to be specified. The description of the disposal operation includes the position of the disposal barge or hopper dredge on the grid; the barge or hopper dredge velocity, dimensions, and draft; and volume of dredged material to be dumped. Coefficients are required for the model to accurately specify entrainment, settling, drag, dissipation, apparent mass, and density gradient differences. These coefficients have default values that should be used unless other site-specific information is available. Table D1 lists the necessary input parameters with their corresponding units. Table D1 also lists the input parameters for determining the contaminant of concern to be modeled based on dilution needs. More detailed descriptions and guidance for selection of values for many of the parameters are provided directly on-line in the system.

Model Output

The output starts by echoing the input data and then optionally presenting the time history of the descent and collapse phases. In descent history, the location of the cloud centroid, the velocity of the cloud centroid, the radius of the hemispherical cloud, the density difference between the cloud and the ambient water, the conservative constituent concentration, and the total volume and concentration of each solid fraction are provided as functions of time since release of the material.

At the conclusion of the collapse phase, time-dependent information concerning the size of the collapsing cloud, its density, and its centroid location and velocity as well as contaminant and solids concentrations can be requested. The model performs the numerical integrations of the governing conservation equations in the descent and collapse phases with a minimum of user input. Various control parameters that give the user insight into the behavior of these computations are printed before the output discussed above is provided.

At various times, as requested through input data, output concerning suspended sediment concentrations can be obtained from the transport-diffusion computations. With Gaussian cloud transport and diffusion, only concentrations at the water depths requested are provided at each grid point.

For evaluations of initial mixing, results for water column concentrations can be computed in terms of milligrams per liter of dissolved constituent for Tier II evaluations or in percent of initial concentration of suspended plus dissolved constituents in the dredged material for Tier III evaluations. The maximum concentration within the grid and the maximum concentration at or outside the boundary of the disposal site are tabulated for specified time intervals. Graphics showing the maximum concentrations inside the disposal-site boundary and anywhere on the grid as a function of time can also be generated. Similarly, contour plots of concentration can be generated at the requested water depths and at the selected print times.

Target Hardware Environment

The system is designed for the 80386-based processor class of personal computers using DOS. This does not constitute official endorsement or approval of these commercial products. In general, the system requires a math coprocessor, 640 KB of RAM, and a hard disk. The STFATE executable model requires about 565 KB of free RAM to run; therefore, it may be necessary to unload network and TSR software prior to execution. The model is written primarily in Fortran 77, but some of the higher level operations and file-management operations are written in BASIC; some of the screen control operations in the Fortran 77 programs are performed using an Assembly language utility program.

Availability of Models

All U.S. Army Engineer Waterways Experiment Station (WES) computer models referred to in this report are available as a part of the Automated Dredging and Disposal Alternatives Modeling System (ADDAMS), and can be downloaded from the World Wide Web from the WES Dredging Operations Technical Support (DOTS) homepage at <http://www.wes.army.mil/el/dots/dots.html>.

References

- Brandsma, M. G., and Divoky, D. J. (1976). "Development of models for prediction of short-term fate of dredged material discharged in the estuarine environment," Contract Report D-76-5, U.S. Army Engineer Waterways Experiment Station, Vicksburg, MS.
- Johnson, B. H. (1990). "User's guide for models of dredged material disposal in open water," Technical Report D-90-5, U.S. Army Engineer Waterways Experiment Station, Vicksburg, MS.
- Koh, R. C. Y., and Chang, Y. C. (1973). "Mathematical model for barged ocean disposal of waste," Environmental Protection Technology Series EPA 660/2-73-029, U.S. Army Engineer Waterways Experiment Station, Vicksburg, MS.
- Schroeder, P. R., and Palermo, M. R. (1990). "Automated dredging and disposal alternatives management system, User's Guide," Technical Note EEDP-06-12, U.S. Army Engineer Waterways Experiment Station, Vicksburg, MS.
- U.S. Environmental Protection Agency/U.S. Army Corps of Engineers. (1991). "Evaluation of dredged material proposed for ocean disposal (Testing Manual)," EPA-503/8-91/001, Office of Water, U.S. Environmental Protection Agency, Washington, DC.
- _____. "Evaluation of dredged material proposed for discharge in inland and near-coastal waters - Testing manual," Report in preparation, U.S. Environmental Protection Agency, Washington, DC.

Table D1 STFATE Model Input Parameters			
Parameter	Disposal Operation Types¹	Units	Options²
Contaminant Selection Data			
Solids concentration of dredged material		g/L	
Contaminant concentration in the bulk sediment		µg/kg	
Contaminant concentration in the elutriate		µg/L	
Contaminant background concentration at disposal site		µg/L	
Contaminant water quality standards		µg/L	
Site Description			
Number of grid points (left to right)	H, B		
Number of grid points (top to bottom)	H, B		
Spacing between grid points (left to right)	H, B	ft	
Spacing between grid points (top to bottom)	H, B	ft	
Constant water depth	H, B	ft	C
Roughness height at bottom of disposal site	H, B	ft	
Slope of bottom in x-direction	H, B	degrees	
Slope of bottom in z-direction	H, B	degrees	
Number of points in density profile	H, B		
Depth of density profile point	H, B	ft	
Density at profile point	H, B	g/cc	
Salinity of water at disposal site	H, B	ppt	Optional
Temperature of water at disposal site	H, B	Celsius	Optional
Grid points depths	H, B	ft	V
Velocity Data			
Type of velocity profile	H, B		
Water depth for averaged velocity	H, B	ft	
Vertically averaged x-direction velocity	H, B	ft/sec	
<i>(Sheet 1 of 4)</i>			
¹ The use of a parameter for disposal operations by a multiple bin hopper dredge is indicated in the table by an H, while a parameter used for disposal from a split-hull barge or scow is indicated by a B. ² The use of a parameter for the constant depth option or variable depth option is indicated in the table by a C or V, respectively. Other optional uses for parameters are so indicated.			

Table D1 (Continued)			
Parameter	Disposal Operation Types	Units	Options
Velocity Data (Continued)			
Vertically averaged z-direction velocity	H, B	ft/sec	
Water depths for 2-point profile	H, B	ft	
Velocities for 2-point profile in x-direction	H, B	ft/sec	
Velocities for 2-point profile in z-direction	H, B	ft/sec	
Velocities for entire grid in x-direction	H, B	ft/sec	
Velocities for entire grid in z-direction	H, B	ft/sec	
Input, Execution, and Output Keys			
Processes to simulate	H, B		
Duration of simulation	H, B	sec	
Long-term time step for diffusion	H, B	sec	
Convective descent output option	H, B		
Collapse phase output option	H, B		
Number of print times for long-term diffusions	H, B		
Location of upper left corner of mixing zone on grid	H, B	ft	
Location of lower right corner of mixing zone on grid	H, B	ft	
Water quality standards at border of mixing zone for contaminant of concern	H, B	mg/L	
Contaminant of concern	H, B		
Contaminant concentration in sediment	H, B	mg/kg	
Background concentration at disposal site	H, B	mg/L	
Location of upper left corner of zone of initial dilution (ZID) on grid	H, B	ft	
Location of lower right corner of ZID on grid	H, B	ft	
Water quality standards at border of ZID for contaminant of concern	H, B	mg/L	
Number of depths in water column for which output is desired	H, B		
Depths for transport - diffusion output	H, B	ft	
Predicted initial concentration in fluid fraction	H, B	mg/L	
Dilution required to meet toxicity standards	H, B	percent	
Dilution required to meet toxicity standards at border of ZID	H, B	percent	
<i>(Sheet of 2 of 4)</i>			

Table D1 (Continued)			
Parameter	Disposal Operation Types	Units	Options
Material Description Data			
Total volume of dredged material in the hopper dredge	H	yd ³	
Number of distinct solid fractions	H, B		
Solid-fraction descriptions	H, B		
Solid-fraction specific gravity	H, B		
Solid-fraction volumetric concentration	H, B	yd ³ /yd ³	
Solid-fraction fall velocity	H, B	ft/sec	
Solid-fraction deposited void ratio	H, B		
Solid-fraction critical shear stress	H, B	lb/sq ft	
Cohesive? (yes or no)	H, B		
Stripped during descent? (yes or no)	H, B		
Moisture content of dredged material as multiple of liquid limit	H, B		Cohesive
Water density at dredging site	H, B	g/cc	
Salinity of water at dredging site	H, B	ppt	Optional
Temperature of water at dredging site	H, B	Celsius	Optional
Desired number of layers	B		
Volume of each layer	B	yd ³	
Velocity of vessel in x-direction during dumping of each layer	B	ft/sec	
Velocity of vessel in z-direction during dumping of each layer	B	ft/sec	
Disposal Operation Data			
Location of disposal point from top of grid	H, B	ft	
Location of disposal point from left edge of grid	H, B	ft	
Length of disposal vessel bin	H, B	ft	
Width of disposal vessel bin	H, B	ft	
Distance between bins	H	ft	
Predisposal draft of hopper	H	ft	
Postdisposal draft of hopper	H	ft	
Time required to empty all hopper bins	H	sec	
Number of hopper bins opening simultaneously	H		
(Sheet 3 of 4)			

Table D1 (Concluded)			
Parameter	Disposal Operation Types	Units	Options
Disposal Operation Data (Continued)			
Number of discrete openings of sets of hopper bins	H		
Vessel velocity in x-direction during each opening of a set of hopper bins	H	ft/sec	
Vessel velocity in z-direction during each opening of a set of hopper bins	H	ft/sec	
Bottom depression length in x-direction	H, B	ft	Optional
Bottom depression length in z-direction	H, B	ft	Optional
Bottom depression average depth	H, B	ft	Optional
Predisposal draft of disposal vessel	B	ft	
Postdisposal draft of disposal vessel	B	ft	
Time needed to empty disposal vessel	B	sec	
Coefficients			
Settling coefficient	H, B		
Apparent mass coefficient	H, B		
Drag coefficient	H, B		
Form drag for collapsing cloud	H, B		
Skin friction for collapsing cloud	H, B		
Drag for an ellipsoidal wedge	H, B		
Drag for a plate	H, B		
Friction between cloud and bottom	H, B		
4/3 Law horizontal diffusion dissipation factor	H, B		
Unstratified water vertical diffusion coefficient	H, B		
Cloud/ambient density gradient ratio	H, B		
Turbulent thermal entrainment	H, B		
Entrainment in collapse	H, B		
Stripping factor	H, B		
<i>(Sheet 4 of 4)</i>			

Appendix E

Multiple Dump Fate (MDFATE) of Dredged Material Model

Introduction

This appendix provides information on the computer program Multiple Dump Fate (MDFATE) formally known as Open-Water Disposal Area Management Simulation (ODAMS) (Moritz and Randall 1995). MDFATE is a site management tool that bridges the gap between the STFATE (Johnson 1990) and LTFATE (Scheffner et al. 1995) models. It simulates multiple disposal events at one site to predict the creation of navigation hazards, examine site capacity, and conduct long-term site planning. MDFATE uses modified versions of STFATE and LTFATE for simulations. Similar to LTFATE, local wave and tide information input is required as well as disposal-site boundaries and bathymetry. The disposal-site bathymetry can be either automatically generated (flat or sloping), or actual bathymetric data from an ASCII file can be imported. The suspended solids and conservative tracer portions of STFATE are removed so the modified STFATE version models the convective descent, dynamic collapse, and passive diffusion process only.

Because of the modified LTFATE version, MDFATE can also account for cohesive and noncohesive sediment transport, cohesive sediment consolidation, and noncohesive avalanching. MDFATE can also simulate capping based on the slow release of material from a barge/hopper so it may spread evenly on the bottom with a minimum amount of momentum imparted to the primary mound.

This appendix provides an overview of the theoretical background of MDFATE, personal computer (PC) requirements, required input, and typical output.

Overview of MDFATE

MDFATE was developed to address dredged material placement site management issues. By tracking the volume of material placed in an offshore disposal site from multiple dredging operations, site managers can plan for maximum utilization of the site. Multiple disposals that are point dumped during one specific operation can be simulated to determine if navigation obstructions would be created. For site-use planning, MDFATE will ultimately allow site managers to plan for additional disposal sites as sites reach capacity.

While STFATE simulates short-term processes (seconds to hours) and LTFATE simulates long-term processes (days to months) of dredged material mounding, MDFATE brackets these processes by modeling the accumulation of material on the bottom resulting from multiple disposals.

MDFATE may be roughly categorized into three primary components: grid generation, model execution, and postprocessing. The initial step in executing MDFATE and the foundation of the model is grid generation. Subsequent to grid generation, model execution consists of running the modified versions of LTFATE and STFATE, which provide information to augment the grid. Post-processing consists of various plotting routines to present model results.

Disposal site-grid generation is based on a user-specified horizontal control (state plane or latitude-longitude) to create a horizontal grid. Presently, MDFATE can accommodate a grid with 40,000 nodes, which will allow representation of a disposal site up to approximately 22,000 by 22,000 ft (100-ft grid interval). ODMDS corner points are specified by the user, and MDFATE creates the horizontal grid based on desired grid intervals.

Vertical control is based on a user-specified datum. MDFATE can automatically create a uniform flat or sloping bottom based on the datum of interest, or MDFATE can overlay actual bathymetric data in ASCII form and apply it to the horizontal grid by a multipoint polynomial interpolation.

Once grid generation is completed, MDFATE can simulate multiple (hundreds) disposal events that can extend over 1 year. The disposal operation is broken down into individual week-long episodes during which long-term processes are simulated by the modified version of LTFATE. Within each week-long episode, the modified version of STFATE is executed that simulates dredged material dumped through the water column to bottom accumulation. Cumulative results are generated for self-weight consolidation, sediment transport by waves and currents, and mound avalanching.

The original version of STFATE simulates single disposal events (i.e., one dump) to model water column concentrations of suspended solids and a conservative tracer (not done for MDFATE version). STFATE also generates a disposal mound footprint identifying the extent of dredged material coverage for the dump as well as mound volume and thickness. Water column currents can be

accounted for as well as sloping or depression disposal areas. Differences in material composition can be considered, and layering of different materials in the hopper can be modeled also. Based on material properties, currents, etc., stripping of fines is accounted for, and an estimate of how the material accumulates on the seafloor is provided. STFATE output consists of plots of mound footprint coverage and thickness of bottom accumulation. MDFATE modifies the existing bathymetric grid according to the STFATE-predicted mound footprint and bottom thickness. Subsequent STFATE outputs are appended to the grid, thus creating a composite mound.

For the week-long simulations, LTFATE models the long-term processes affecting the created composite mound. The processes modeled include morphological changes resulting from cohesive and noncohesive sediment erosion, noncohesive sediment avalanching, and cohesive sediment consolidation. For the sediment erosion processes, LTFATE requires input from hydrodynamic databases for tides and waves. The tidal current time-series is generated from user-specified tidal constituents for the site of interest by the program TIDE. Wave statistics from the Wave Information Study (WIS) are used (provided by the user for the site of interest) by the program HPDSIM to generate a wave time-series and ultimately wave-induced currents. The net resulting tidal and wave currents are then used to drive the sediment transport portion of the model. These two routines are also used by the STFATE model within MDFATE to generate the water column currents that affect material settling for the short-term processes.

A summary of the noncohesive and cohesive sediment transport algorithms used by MDFATE can be found in the description of LTFATE (Appendix F).

The avalanching routine applied in LTFATE is based on a routine developed by Larson and Kraus (1989), who adapted the work of Allen (1970) on slope failure. Allen's (1970) experiments showed that two limiting slopes occurred, angle of initial yield and the residual angle after shearing, which were influenced by the particle deposition-rate gradient, particle concentration at the time of deposition, and particle size and density. Allen (1970) examined the effect of a larger deposition rate at the top of a slope versus the toe of a slope, which in effect produced a steepening by rotating the slope around the toe. When the slope becomes unstable, it avalanches, and a new more stable slope is formed.

To account for consolidation of cohesive sediment, the procedure developed by Poindexter-Rollings (1990) for predicting the behavior of a subaqueous sediment mound was followed. The consolidation calculations used by Poindexter-Rollings (1990) and used in LTFATE were based on finite strain theory introduced by Gibson, England, and Hussey (1967). Numerical solutions were developed by Cargill (1982, 1985). Finite strain theory is well-suited for the prediction of consolidation in cases of thick deposits of fine-grained sediments because it provides for the effect of self-weight, permeability that varies with void ratio, nonlinear void ratio-effective stress relationship, and large strains (Scheffner et al. 1995).

Data Requirements

Data requirements for running MDFATE are much the same as those for STFATE (Appendix D) and LTFATE (Appendix F). As described previously, the user must specify ODMDS corner coordinates and interval size for grid generation. Bathymetric data (including datum) must be provided from an external source or automatically generated. Site locations must be identified to specify necessary constituents for the tidal constituent program and to create the wave time series from the WIS location of interest. Other data needs include volume of material to be dredged, dredged material properties (i.e., composition, voids, density, etc.), characteristics of disposal equipment, disposal duration, water column data (density, currents), and method of disposal vessel control. Four options exist for simulating disposal vessel control:

- a.* Disposal within a given radial distance of a specific geographic location (i.e., disposal within a certain radius of a buoy). Dumps are randomly placed with a bias applied toward the direction of approach of the disposal vessel.
- b.* Disposals along transect lines identified by starting and ending coordinates.
- c.* User-specified coordinates for each disposal load.
- d.* Prerecorded coordinates for each disposal load.

System Requirements

Recommended minimum system requirements for running MDFATE are as follows:

- a.* IBM compatible 486.
- b.* DOS version 5.0 or greater.
- c.* 592 KB RAM.
- d.* 8 MB available hard disk space.
- e.* Printer capable of printing graphics (recommended).

Postprocessing

Model output from MDFATE consists of two-dimensional (2-D) contour plots and 3-D surface images. Output can be either viewed within MDFATE or data exported to an external graphics package for plotting. MDFATE also allows grid comparison where before/after scenarios can be examined to analyze mounding and/or erosion of a dredged material mound. Generic mounds may also be created to model long-term morphological behaviors.

Capping Option

A dredged material capping option was developed for inclusion in the MDFATE model. It is based on a modification to STFATE that allows for the slow release of material from a barge/hopper so it may spread evenly on the bottom with a minimum amount of momentum. The capping option specifically addresses the short-term processes that affect dredged material as it experiences passive transport, diffusion, and settling of solids based on individual particle fall speed. The capping option assumes the material will be placed along multiple transects that are repeated and offset to achieve the desired cap thickness.

The STFATE model and its associated grid domain is used as a kernel within the MDFATE grid domain for every disposal/capping event. The capping module uses STFATE with a grid limited to 25 by 25 square elements as opposed to the standard 45 by 45 rectangular grid elements available in the original version of STFATE. If the capping site is large, each load of cap material may require partitioning to ensure its fit within the adapted STFATE grid. Running the adapted STFATE grid as a kernel within the MDFATE grid and possible material partitioning contributes to a higher level of complexity for the capping module than for MDFATE alone. This complexity, therefore, leads to increased execution time.

Two disposal methods can be simulated with the capping module. One method is the slow release of cap material through the slightly cracked (1 to 2 ft) split hull of a split hull barge/hopper dredge. The second method simulates hydraulic pipeline discharge from a hopper dredge reversing its dredge pumps. The simulation can be either for pumping in the direction of vessel transport or counter to vessel transport as the vessel transects the disposal area.

Due to the DOS 640K memory limitations, the capping module must be run independently of the LTFATE long-term processes simulation. If the user desires to simulate both capping and long-term processes, the MDFATE capping module must first be executed followed by the LTFATE portion of MDFATE.

Typical Output

Figures E1 and E2 show typical MDFATE graphical output, 2-D and 3-D contour plots of bathymetry resulting from MDFATE simulations. Textual output consists of tables showing locations of the dumps, volume differences between two bottom bathymetries, and maximum elevation of mounds created. Also, ASCII files containing tables showing the amount of sediments on the bottom and in the water column, identical to those produced by STFATE are created. Finally, the velocity of the descending jet can also be determined from the STFATE-like files.

Availability of Models

All U.S. Army Engineer Waterways Experiment Station (WES) computer models referred to in this report are available as a part of the Automated Dredging and Disposal Alternatives Modeling System (ADDAMS) and can be downloaded from the World Wide Web from the WES Dredging Operations Technical Support (DOTS) homepage at <http://www.wes.army.mil/el/dots/dots.html>.

References

- Ackers, P., and White, W. R. (1973). "Sediment transport: New approach and analysis," *Journal of the Hydraulics Division, Proceedings of the American Society of Civil Engineers* 99 (HY11).
- Allen, J. R. L. (1970). "The avalanching of granular solids on dune and similar slopes," *Journal of Geology* 78.
- Ariathurai, R., MacArthur, R. C., and Krone, R. B. (1977). "Mathematical model of estuarial sediment transport," Technical Report D-77-12, U.S. Army Engineer Waterways Experiment Station, Vicksburg, MS.
- Cargill, K. W. (1982). "Consolidation of soft layers by finite strain analysis," Miscellaneous Paper GL-82-3, U.S. Army Engineer Waterways Experiment Station, Vicksburg, MS.
- _____. (1985). "Mathematical model for the consolidation/desiccation process in dredged material," Technical Report D-85-4, U.S. Army Engineer Waterways Experiment Station, Vicksburg, MS.

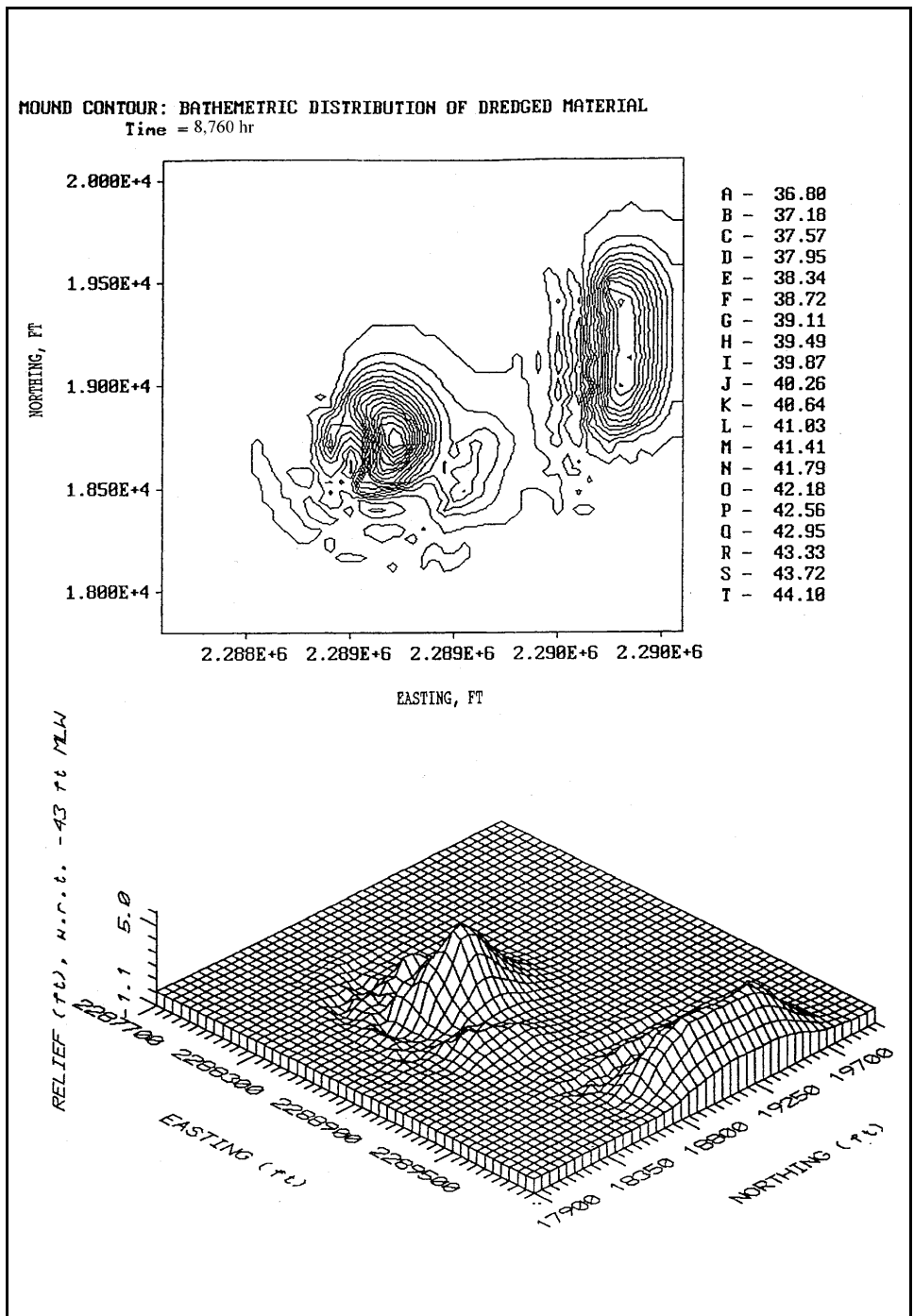

Figure E1. Typical MDFATE model output showing differences between pre-disposal and postdisposal bathymetry

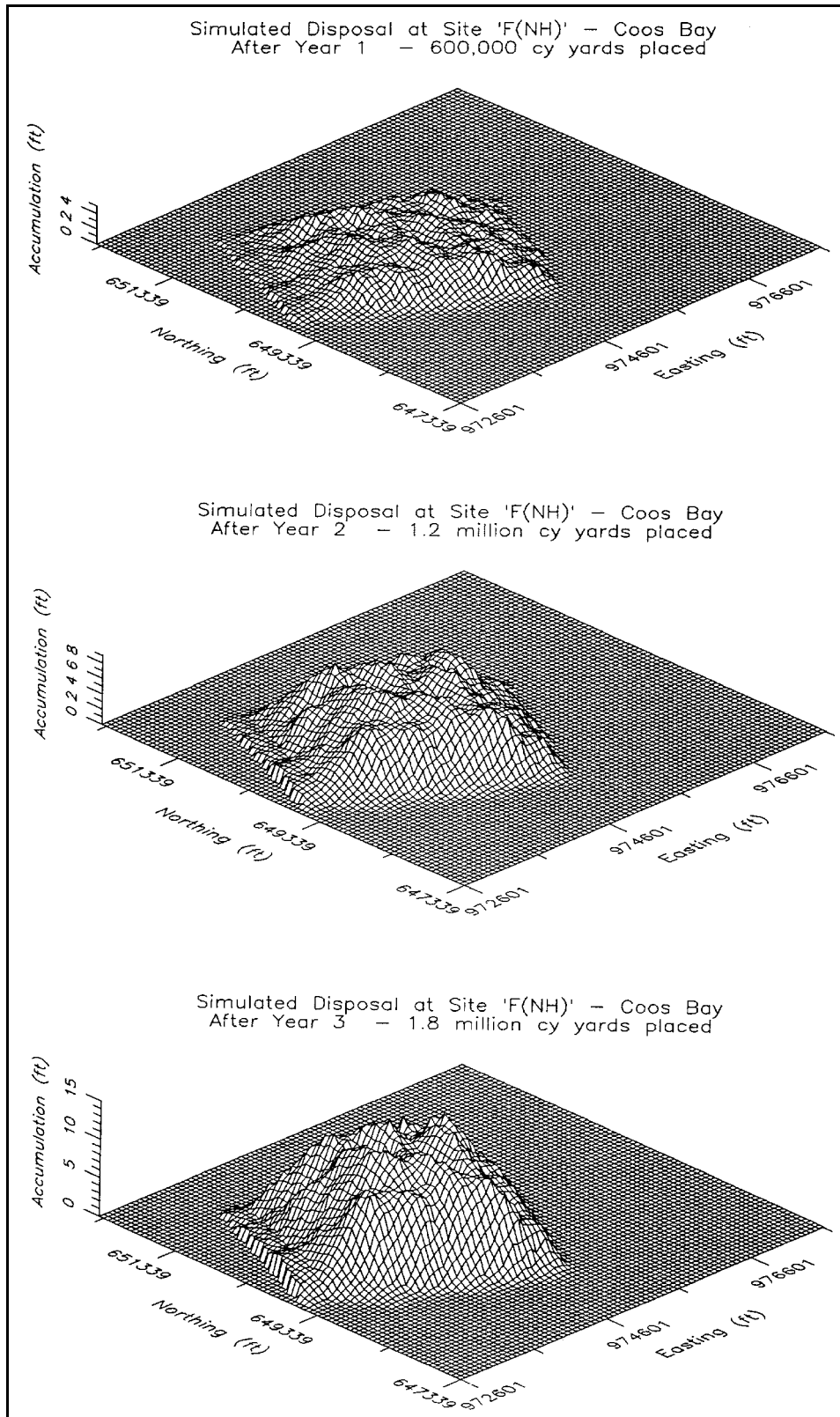

Figure E2. Typical MDFATE model output showing mound formation 1-3 years of disposal at Coos Bay

- Gibson, R. E., England, G. L., and Hussey, M. J. L. (1967). "The theory of one-dimensional consolidation of saturated clays; I. Finite non-linear consolidation of thin homogeneous layers," *Geotechnique* 17, 261-273.
- Johnson, B. H. (1990). "User's guide for models of dredged material disposal in open water," Technical Report D-90-5, U.S. Army Engineer Waterways Experiment Station, Vicksburg, MS.
- Larson, M., and Kraus, N. C. (1989). "SBEACH: Numerical model for simulating storm induced beach change, Report 1: Empirical foundation and model development," Technical Report CERC-89-9, U.S. Army Engineer Waterways Experiment Station, Vicksburg, MS.
- Moritz, H. R., and Randall, R. E. (1995). "Simulating dredged-material placement at open-water disposal sites," *Journal of Waterway, Port, Coastal, and Ocean Engineering* 121(1).
- Poindexter-Rollings, M. E. (1990). "Methodology for analysis of subaqueous sediment mounds," Technical Report D-90-2, U.S. Army Engineer Waterways Experiment Station, Vicksburg, MS.
- Scheffner, N. W., Thevenot, M. M., Tallent, J. R., and Mason, J. M. (1995). "LTFATE: A model to investigate the long-term fate and stability of dredged material disposal sites; User's guide," Instruction Report DRP-95-1, U.S. Army Engineer Waterways Experiment Station, Vicksburg, MS.
- Teeter, A. M., and Pankow, W. (1989). "Schematic numerical modeling of harbor deepening effects on sedimentation, Charleston, SC," Miscellaneous Paper HL-89-7, U.S. Army Engineer Waterways Experiment Station, Vicksburg, MS.
- White, P. (1972). "A sediment transport in channels: A general function," Report Int 104, Hydraulics Research Station, Wallingford, England.

Appendix F

Long-Term Fate (LTFATE) of Dredged Material Model

Introduction

This appendix provides information on the computer program used to execute the Long Term FATE (LTFATE) model. LTFATE is a site-evaluation tool that estimates the dispersion characteristics of a dredged material placement site over long periods of time, ranging from days for storm events to a year or more for ambient conditions. Simulations are based on the use of local wave and currents input to the model. Local, site-specific hydrodynamic input information is developed from numerical model-generated databases; however, user-supplied data files can be substituted for the database-generated files described in this report.

LTFATE has the capability of simulating both noncohesive and cohesive sediment transport. In addition, avalanching of noncohesive sediments and consolidation of cohesive sediments are accounted for to accurately predict physical processes that occur at the site. It should be emphasized that LTFATE, although demonstrated to accurately simulate mound movement, is still under development. Modifications are underway that will improve the basic description of sediment processes. These additions include modifications for mounds on a sloped bottom bathymetry and layering of sediments to account for the decrease in cohesive sediment resuspension potential with depth. Also, additional field and laboratory work are necessary to fully understand (and thus be able to model) cohesive sediment erosion and deposition processes under high shear stresses. LTFATE is designed to lend itself easily to code modification to include new processes.

This appendix provides an overview of the theoretical background on which the model is based, the personal computer (PC) requirements to run the model, required input, and typical output. Details on all of these aspects can be found in Scheffner et al. 1995.

Overview of LTFATE

LTFATE is a site-analysis program that uses coupled hydrodynamic, sediment transport, and bathymetry change models to compute site stability over time as a function of local waves, currents, bathymetry, and sediment size. LTFATE was developed to simulate the long-term fate and stability of dredged material placed in open water with an initial intended use for classifying existing or proposed disposal sites as dispersive or nondispersive. If the site is demonstrated to be dispersive, model output will provide an estimate of the temporal and spatial fate of the eroded material. This determination is often difficult to quantify because the movement of sediment is a function of not only the local bathymetry and sediment characteristics, but also the time-varying wave and current conditions. LTFATE overcomes these difficulties by using an information database to provide design wave and current time series boundary conditions that realistically represent conditions at the candidate disposal site.

The wave simulation methodology and the elevation and current databases referenced in this report were developed through the Dredging Research Program (DRP) at the U.S. Army Engineer Waterways Experiment Station (WES). The procedures for generating stochastic wave height, period, and direction time series are reported in Borgman and Scheffner (1991). The database of tidal elevations and currents for the east coast, Gulf of Mexico, and Caribbean Sea are described in Westerink, Luettich, and Scheffner (1993), and the database of tropical storm surge and current hydrographs is reported in Scheffner et al. (1994). These data are used to generate wave and current boundary condition data for use as input to LTFATE for evaluating mound stability. If these databases are not available for the geographic area of interest to the user, then replacement input files will have to be supplied by the user and copied into the appropriately designated files.

Noncohesive mound movement

The LTFATE model uses four coupled subroutines to predict dredged material movement of various types of noncohesive material during different stages of mound evolution. These subroutines simulate hydrodynamics, sediment transport, mound cascading, and bathymetry change. LTFATE uses the equations reported by Ackers and White (1973) as the basis for the noncohesive sediment transport model. The equations are applicable to uniformly graded noncohesive sediment with a grain diameter in the range of 0.04 to 4.0 mm (White 1972). Because many disposal sites are located in relatively shallow water, a modification of the Ackers-White equations was incorporated to reflect an increase in the transport rate when ambient currents are accompanied by surface waves. The modification is based on an application of the concepts developed by Bijker (1971) and enhanced by Swart (1976). This preliminary model was verified to prototype data by Scheffner (1991) and was shown to be a viable approach to providing quantitative predictions of disposal-site stability.

Kraus and Larson (1988) found that in some large wave tank cases, the local slope of a mound of noncohesive material exceeded the angle of repose due to constant waves and water levels. Therefore, the concept of slope failure was incorporated in LTFATE to ensure stability of the dredged material mound by employing an algorithm developed by Larson and Kraus (1989). The algorithm is based on laboratory studies conducted by Allen (1970), who investigated steepening of slopes consisting of granular solids. Allen (1970) recognized two limiting slopes, the angle of initial yield and the residual angle after shearing. If the slope exceeds the angle of initial yield, material is redistributed along the slope through avalanching, and a new stable slope is attained, known as the residual angle after shearing.

Cohesive mound movement

An improved cohesive sediment transport model has recently been incorporated into LTFATE to account for transport of fine-grained material, i.e., silts and clays. Fine-grained sediments are hydraulically transported almost entirely in suspension rather than as bed load; therefore, the Ackers-White equations are not applicable for these conditions. The cohesive sediment transport model requires bottom shear stress as input. The total bottom shear stress due to currents and waves is determined using the combined current/wave >perceived velocity=, V_{wc} (Bijker 1971; Swart 1976) and bottom roughness parameters. This method for calculating shear stress, like most others, is influenced by bottom roughness parameters. These parameters are frequently not available for the study area, and the results may change significantly depending on their values. Bottom roughnesses for typical ocean sediments can be used in lieu of actual data.

The factors influencing the resistance of a cohesive sediment bed to erosion may be best described by Ariathurai and Krone (1976) as: (a) the types of clay minerals that constitute the bed; (b) structure of the bed (which in turn depends on the environment in which the aggregates that formed the bed were deposited), time, temperature, and the rate of gel formation; (c) the chemical composition of the pore and eroding fluids; (d) stress history, i.e., the maximum overburden pressure the bed had experienced and the time at various stress levels; and (e) organic matter and its state of oxidation. It is obvious from this description that the resistance of the bed to erosion will be different not only from site to site, but also potentially with depth at a given location. Therefore, erosion potential is usually considered a site-specific function of shear stress (and sometimes depth). Methods have been developed to determine erosion based on stresses, but these equations require parameters whose values are site specific. A commonly used method of relating erosion to shear stress has been incorporated into LTFATE. This method relates erosion as a function of shear stress to some exponential power. The equation for the erosion rate in grams/square centimeter/second is:

$$\varepsilon = A_0 \left(\frac{J - J_{cr}}{J_r} \right)^m$$

where

A_0 and m = site-specific parameters

J = shear stress due to currents and waves

J_{cr} = site-specific critical shear stress below which no erosion occurs
(which can reasonably be set to 5 *dynes/cm*² if site data are not available)

J_r = a reference shear stress (assumed to be 1 *dyne/cm*²)

Most research on cohesive sediment erosion has been performed in laboratory settings at moderate shear stresses less than 20 *dynes/cm*² (Lavelle, Mofjeld, and Baker 1984). The method incorporated into LTFATE was developed for moderate stresses. Data for high shear stresses are sparse, and the experimental methods are still under development (McNeil, Taylor, and Lick 1996). Despite this, a lot can be determined by using the moderate shear equations in high-shear regions. It would appear from bathymetry measurements in high-shear regions that the above equation can adequately simulate these conditions.

It should be noted that the values of the site-specific parameters used in these methods can vary significantly. Experimentally determined values of A_0 range over several orders of magnitude from 1×10^{-9} to 5×10^{-6} (*g/cm*²/*sec*) and m ranges from 1 to 5 (Lavelle, Mofjeld, and Baker 1984). The experimental range of exponent m values coupled with the equation for J demonstrate that the relationship between velocity and erosion is highly nonlinear (J is a function of V^2 and ε is a function of J^m resulting in ε is a function of V^{2m}). Therefore, the rare storm events will produce most of the cohesive sediment erosion for a given year. This is well known to occur in many rivers, lakes, and nearshore environments. Some studies on San Francisco Bay sediments suggest that m ranges from 1-2 for these sediments, assuming they have had long compaction periods (Parthenaides 1965). The higher values of m are reserved for freshwater lake and river sediments. For application of LTFATE, erosion tests should be performed on site sediments. If at all possible, values for A_0 and m should be determined from laboratory experiments on sediment cores extracted from the study area. If no such data are available, values for A_0 and m can be set to 7.6×10^{-8} *g/cm*²/*sec* and 2, respectively. These values will produce a decent conservative (i.e., high) estimate for erosion potential. They were developed for recently deposited sediments at the New York Bight Mud Dump site. They will produce a conservative estimate because they are for recently deposited, and therefore more easily resuspended, sediments.

Required hardware

The following are recommended minimum hardware requirements for running the LTFATE interface on a PC with a standard Disk Operating System (DOS) Version 3.3 or greater:

- a.* 386-25 MHZ processor (faster processors are recommended, they greatly reduce execution time).
- b.* Math coprocessor.
- c.* 620 K resident memory.
- d.* VGA monitor (required).
- e.* Hard disk with several megabytes free.
- f.* HP LaserJet II or III (or compatible) printer for hard copy.

A compiler is not required because the LTFATE interface and model are distributed as executable files together with several data files. The PC version of the LTFATE interface may access all memory within the 640-K DOS limit. Therefore, the LTFATE interface should be run from the DOS prompt with all resident memory programs removed to ensure enough memory exists for model execution. The graphic routine provided in this package, HGRAPH,¹ is non-proprietary and property of the U.S. Government.

Program files

The LTFATE package presently consists of the following three main programs:

- a.* PC_WAVEFIELD.
- b.* PC_TIDAL.
- c.* PC_LTFATE.

LTFATE in its entirety may be used as a complete site evaluation package, or individual programs may be accessed independently for other applications.

PC_WAVEFIELD creates a time series of wave height, period, and direction based on the computed intercorrelation matrix describing the statistical properties of wave height, period, and direction, and their respective interrelationships.

¹ The program HGRAPH was developed by Mr. David W. Hyde, Structural Engineer, WES, Structures Laboratory, Vicksburg, MS.

The matrix is computed from a time series of data corresponding to the location of interest.

In PC_TIDAL, a database containing the harmonic constituents for tidal elevation and currents for a site-specific location are used to generate an arbitrarily long sequence of tidal data. PC_TIDAL includes the following two options: (a) simulation of the long-term tide sequence, and (b) generation of time history plots for the tide elevation, velocity components, and direction.

Lastly, the program PC_LTFATE automatically accesses data generated by the programs PC_WAVEFIELD and PC_TIDAL to simulate long-term dredged material mound movement. These two programs require input files describing the statistical distribution of a site-specific wave field and tidal harmonic constituents relative to that site. If these data are not available, the user is required to supply the appropriately named files to substitute for the output files ordinarily generated by the programs PC_WAVEFIELD and PC_TIDAL.

The PC_LTFATE program should be employed only after executing programs PC_WAVEFIELD and PC_TIDAL. PC_LTFATE includes the following four options: (a) seabed geometry configuration program, (b) simulation of dredged material mound movement, consolidation, and avalanching, (c) generation of dredged material mound evolution contour plots, and (d) generation of dredged material mound evolution cross-sectional plots.

Databases for waves, tides, and storm surge to support LTFATE are available only for the east and Gulf coasts of the United States. For these applications in other areas, the user is required to supply time series data for waves and storm surge (for storm-event applications) or provide tidal elevation and current constituents, and wave time series (for long-term simulations). Therefore, it is assumed that the user is proficient in the use of a PC, is able to use an editor (if necessary), and can write simple data construction programs and manipulate files. These skills are necessary in order to transfer user-supplied data into the PC and copy it into the appropriate files that are accessed by LTFATE.

Three external user-supplied input files are required by the model to specify wave, tidal, and storm surge boundary conditions for a specific location of interest. Site-specific files will have to be obtained (the Coastal and Hydraulics Laboratory (CHL), WES, can provide these files) or generated by the user in order to define wave and current boundary condition input corresponding to the location of interest.

The first of these external files, named TIDAL.DAT, is used to define a time series tidal elevation and current boundary condition at the subject disposal mound. The TIDAL.DAT file contains amplitude and epoch harmonic tidal constituents for both elevation and currents corresponding to the location of the mound.

Because the LTFATE model requires both tidal elevation and current (*U* and *V*) time series input, harmonic constituents for all three variables must be contained in the data file. This input file can be generated through execution of the program TIDES.EXE. However, the TIDES.EXE program requires an input database of harmonic constituents at discrete locations and, through interpolation, generates elevation and current constituents for any desired location into the appropriate format in the file TIDAL.DAT. The constituent database has been generated for the east coast, Gulf of Mexico, and Caribbean Sea (Westrink, Luettich, and Scheffner 1993) and described in DRP Technical Note DRP-1-13 (Scheffner 1994). Constituent output for a specific location can be obtained by contacting CHL. The tidal constituent database for the west coast is currently under development.

If tidal constituent coverage of the area of user interest is not available, tidal constituent data will have to be obtained from alternate sources; for example, WES technical reports, the National Oceanic and Atmospheric Administration, university sources, open literature, etc., or through harmonic analyses of available or collected elevation and current time series. Adequate data are usually available, but will have to be located and supplied by the user. An example use of external data is reported by Scheffner and Tallent (1994). If the user supplies the necessary data, it must be formatted as shown in Table F1 and should be named TIDAL.DAT.

Table F1							
Example LTFATE Tidal Input Data File—TIDAL.DAT							
MOBILE, ALABAMA							
TIDAL HEIGHT HARMONIC CONSTITUENTS (CM/SEC)							
	6	0.0	-5.8	-10.4			
CONST	SPEED-D/H	AMP-M	EPOCH-D	AMP-C/S	EPOCH-D		
AMP-C/S	EPOCH-D						
		HEIGHT		VEL-U		VEL-V	
M2	28.984104	.01	321.00	4.3	46.	6.7	41.
S2	30.000000	.01	309.60	1.2	47.	1.8	5.
N2	28.439730	.00	339.10	0.6	317.	1.2	255.
K1	15.041069	.13	325.70	8.5	229.	14.3	231.
O1	13.943036	.12	313.30	6.7	242.	10.4	235.
M1	14.492754	.00	332.80	0.6	330	0.6	346

The second file required for long-term simulation of dredged material mound movement is a file containing a time series of wave height, period, and direction named HPDSIM.OUT. This file can either be user supplied or generated internally by LTFATE and is in the format shown in Table F2. If LTFATE generates the file, the additional file HPDPRE.OUT is required. The HPDPRE.OUT file represents the precomputed cross-correlation matrix corresponding to a WIS station location nearest the mound. The combined LTFATE/HPDPRE.OUT

Table F2
Example LTFATE Wave Input Data File—HPDSIM.OUT

```

START MO = 3  START YR = 1987  END MO = 8  END YR = 1987
NYR,NNY,NMO=  20 20 12
IYEARS=  1 1 1 1 1 1 1 1 1 1 1 1 1 1 1 1 1 1 1 1 1
MONTHS=  1 1 1 1 1 1 1 1 1 1 1 1
CUTOFF=  0.083333  0.083333  0.083333  0.083333  0.083333
CUTOFF=  0.083333  0.083333  0.083333  0.083333  0.083333
CUTOFF=  0.083333  0.083333
IY=  1 2 3 4 5 6 7 8 9 10 11 12 13 14 15 16 17 18 19 20
IJM=  1 2 3 4 5 6 7 8 9 10 11 12
198703 100      1.00000      5.00002      343.83057
198703 103      1.10000      5.00000      35.42109
198703 106      1.20000      5.00001      52.58537
198703 109      1.20000      5.00000      58.00993
198703 112      1.20000      5.00000      53.44814
198703 115      1.10000      5.00000      36.73721
198703 118      1.00000      5.00000      340.76096
198703 121      0.90000      5.00000      293.34930
198703 200      0.80000      5.00000      283.34152
198703 203      0.76876      5.00000      279.52328
198703 206      0.70000      5.00000      277.62357
198703 209      0.60000      5.00001      276.96350
198703 212      0.60000      5.00000      276.80725
198703 215      0.70000      5.00001      277.28809

```

```

.....
1987082903      0.90000      6.00001      81.11949
1987082906      0.90000      6.00002      81.50021
1987082909      0.90000      5.00002      81.90755
1987082912      0.80001      5.00003      82.21406
1987082915      0.80000      5.00001      82.76773
1987082918      0.70000      5.00002      83.25628
1987082921      0.60000      5.00000      83.61486
1987083000      0.60000      5.00000      83.84423
1987083003      0.60000      5.00002      83.97083
1987083006      0.50000      5.00001      84.04659
1987083009      0.50000      5.00001      84.10904
1987083012      0.50000      5.00000      84.17479
1987083015      0.50000      5.00000      84.23292
1987083018      0.50000      5.00000      84.25816
1987083021      0.60000      5.00003      84.26725
1987083100      0.80000      5.00003      84.27031
1987083103      0.90000      5.00002      84.25816
1987083106      1.00000      6.00002      84.21492
1987083109      1.10000      6.00001      83.96118
1987083112      1.10000      6.00001      83.34565

```

wave simulation capability is described by Borgman and Scheffner (1991) and Scheffner and Borgman (1992). This approach is used to generate an arbitrarily long time sequence of simulated wave data that preserves the primary statistical properties of the full 20-year WIS hindcast, including wave sequencing and seasonality. Once the matrix has been computed, multiple wave field simulations can be performed, with each time series stored on the file HPDSIM.OUT.

The primary advantage of using this statistically based wave simulation approach is that the user is not limited to a finite length of data; instead, seasonal or yearly repetitions of time series can be used for evaluations of site stability. Each simulation will be statistically similar to the hindcast data but will contain variability consistent with observations. If HPDPRE.OUT matrix is not available for the location of interest, one can be computed by the user or by CHL through use of a WIS 20-year hindcast input file and execution of the program HPDPRE. If the location of interest is not covered by the WIS hindcast database, existing time series of wave height, period, and direction will have to be supplied by the user.

The long-term simulations described above, i.e., simulations of months to years, compute disposal mound stability as a function of residual currents specified by the user in LTFATE, the normal seasonal wave climate, and the tidal elevation and currents computed from the specified tidal constituents in the TIDAL.DAT file. Storm-event erosion calculations are based on surge elevation and currents and the wave field associated with that specific event. These data are contained in the final input file required by LTFATE, the file STORM.DAT. This file must be assembled from existing databases or generated by the user. However, the file is required only if the user desires to simulate the passage of a storm event over the disposal site.

The STORM.DAT file contains either a tropical or extratropical storm surge elevation and current time series hydrograph with a corresponding storm wave height and period corresponding to the selected event. A database of tropical storm hydrographs for 134 historically based tropical storms has been completed for the 486 WIS and offshore discrete locations along the east and Gulf of Mexico coasts and for selected stations offshore of Puerto Rico. This database is described by Scheffner et al. (1994). The companion extratropical event database for the east and Gulf coasts and Puerto Rico has been completed.

A wave climate corresponding to the selected event can be obtained from either available data (if the surge is historically based) or estimated as a function of storm-associated or design peak wave height and periods. In the New York Bight Mud Dump example shown in the frequency of erosion appendix, the surge elevation and velocities were obtained from numerical simulations of the December 1992 extratropical event. The wave field corresponding to the December event was obtained from National Data Buoy Center data. For future applications, surge and current information is now available in a DRP database (reference). If wave data are not available for the selected event, then design peak wave height and period estimates can be used.

The STORM.DAT file should be created by the user of LTFATE to describe a particular storm event or a storm event of assumed shape and duration. An example of hypothetical event use in disposal analysis is given in Scheffner and Tallent (1994).

Program Output

As stated above, the LTFATE program can simulate movement of dredged material mounds both over the long-term and for storms. The final output of the model is a file containing the new mound bathymetry. The bathymetry files can be viewed either as plan view contour plots or cross sections. Figure F1 shows the initial bathymetry of a small sand mound placed in shallow water (17 ft) off Mobile, AL. Figure F2 shows the bathymetry of the same mound approximately 6 months later. Figure F3 shows the change in cross section of the mound along a line 1,500 ft below the centerline of the mound.

Availability of Models

All WES computer models referred to in this report are available as a part of the Automated Dredging and Disposal Alternatives Modeling System (ADDAMS) and can be downloaded from the World Wide Web from the WES Dredging Operations Technical Support (DOTS) homepage at <http://www.wes.army.mil/el/dots/dots.html>.

Additional Information

For additional information on the LTFATE program, contact Dr. Norman Scheffner (601) 634-3220 of the Research Division of the Coastal and Hydraulics Laboratory at the U.S. Army Engineer Waterways Experiment Station.

References

- Ackers, P., and White, R. W. (1973). "Sediment transport: New approach and analysis," *Journal of the Hydraulics Division* 99 (HY11), 2041-60.
- Allen, J. R. L. (1970). "The avalanching of granular solids on dune and similar slopes," *Journal of Geology* 78 (3), 326-51.
- Ariathurai, R., and Krone, R. B. (1976). "Finite element model for cohesive sediment transport," *J. Hydraul. Div. Am. Soc. Civ. Eng.* 102(HY3), 323-338.

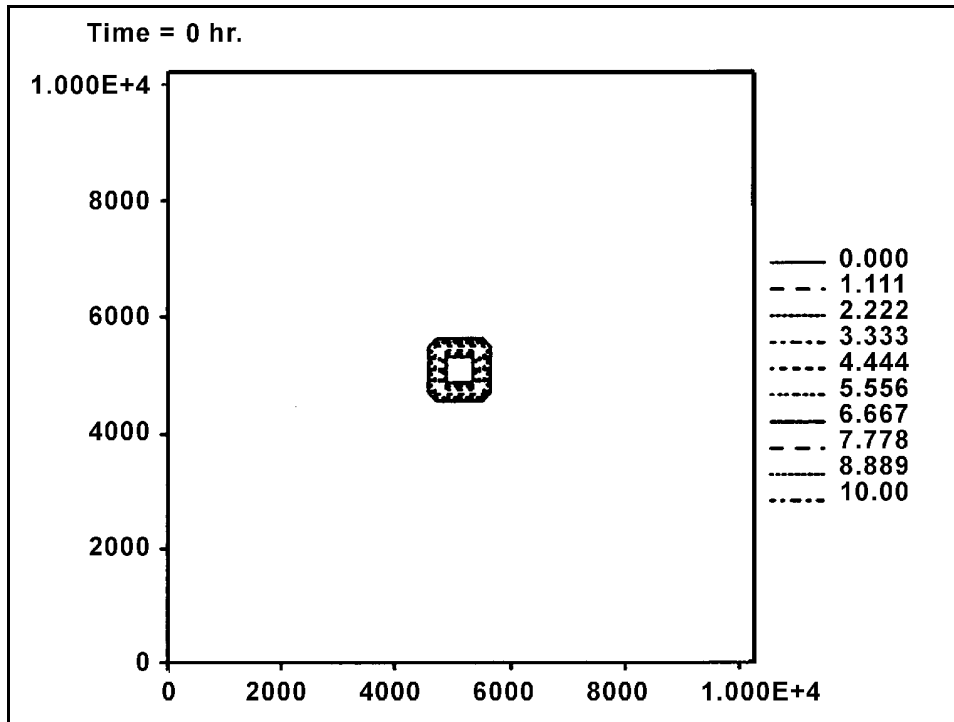

Figure F1. Initial Sand Island mound contours

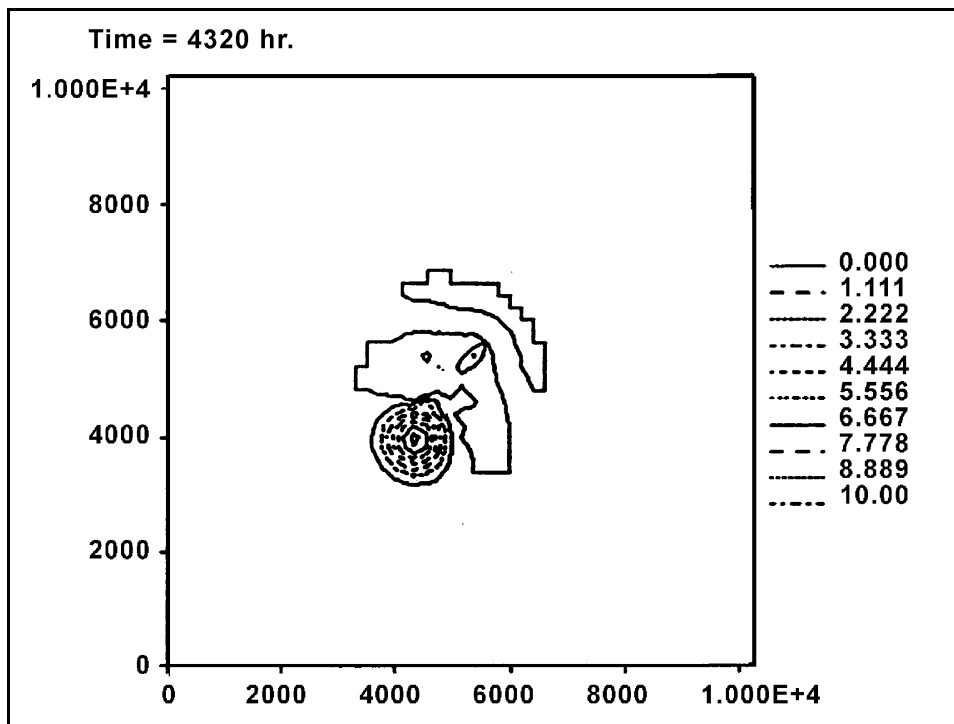

Figure F2. Simulated Sand Island mound contours after 180 days

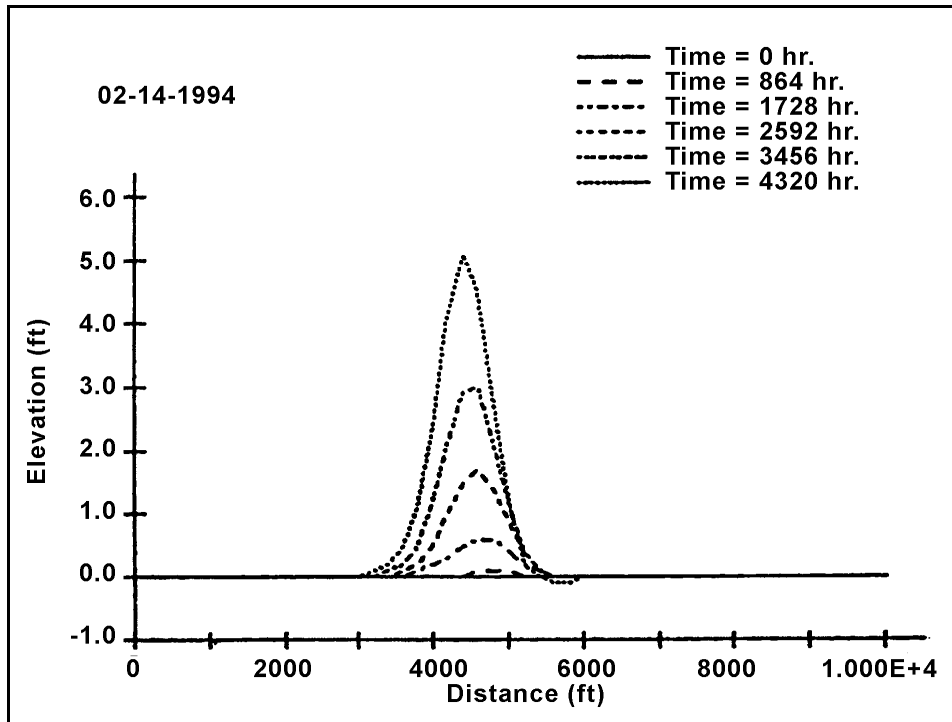

Figure F3. Simulated Sand Island cross section 1,500 ft below centerline

Ariathurai, R., MacArthur, R. C., and Krone, R. B. (1977). "Mathematical model of estuarial sediment transport," Technical Report D-77-12, U.S. Army Engineer Waterways Experiment Station, Vicksburg, MS.

Bijker, E. W. (1971). "Longshore transport computations," *Journal of the Waterways, Harbors, and Coastal Engineering Division (WW4)*, 687-701.

Borgman, L. E., and Scheffner, N. W. (1991). "The simulation of time sequences of wave height, period, and direction," Technical Report DRP-91-2, U.S. Army Engineer Waterways Experiment Station, Vicksburg, MS.

Cargill, K. W. (1982). "Consolidation of soft layers by finite strain theory," Miscellaneous Paper GL-82-3, U.S. Army Engineer Waterways Experiment Station, Vicksburg, MS.

_____. (1985). "Mathematical model of the consolidation/desiccation process in dredged material," Technical Report D-85-4, U.S. Army Engineer Waterways Experiment Station, Vicksburg, MS.

Corson, W. D., Resio, D. T., and Vincent, C. L. (1980). "Wave information study of US coastlines; Surface pressure field reconstruction for wave hind-casting purposes, Report 1," Technical Report HL-80-11, U.S. Army Engineer Waterways Experiment Station, Vicksburg, MS.

- Gibson, R. E., England, G. L., and Hussey, M. J. L. (1967). "The theory of one-dimensional consolidation of saturated clays; I, Finite nonlinear consolidation of thin homogeneous layers," *Geotechnique* 17(3), 261-73.
- Hands, E. B., and Allison, M. C. (1991). "Mound migration in deeper water and methods of categorizing active and stable berms." *Proceedings of Coastal Sediments '91*, ASCE, 1985-99.
- Kraus, N. C., and Larson, M. (1988). "Beach profile change measured in the tank for large waves, 1956-1957 and 1962," Technical Report CERC-86-6, U.S. Army Engineer Waterways Experiment Station, Vicksburg, MS.
- Larson, M., and Kraus, N. C. (1989). "ASBEACH: Numerical model for simulating storm induced beach change, Report 1: Theory and model foundation," Technical Report CERC-89-9, U.S. Army Engineer Waterways Experiment Station, Vicksburg, MS.
- Lavelle, J. W., Mofjeld, H. O., and Baker, E. T. (1984). "An in situ erosion rate for a fine-grained marine sediment," *J. Geophys. Res.* 89(C4), 6543-6552.
- McNeil, J., Taylor, C., and Lick, W. (1996). "Measurements of the erosion of undisturbed bottom sediments with depth," *J. Hydraul. Eng.* 122(6), 316-324.
- Mehta, A. J., Hayter, E. J., Parker, W. R., Krone, R. B., and Teeter, A. M. (1989). "Cohesive sediment transport - I: Process description," *Journal of Hydraulic Engineering*, ASCE 115(3), 1076-93.
- Parthenaides, E. (1965). "Erosion and deposition of cohesive soils," *J. Hydraul. Div. Am Soc. Civ. Eng.* 91(HY1), 105-138.
- Scheffner, N. W. (1989). "Disposal site evaluation for the New York Bight," Coastal Engineering Research Center, U.S. Army Engineer Waterways Experiment Station, Vicksburg, MS.
- _____. (1991). "A systematic analysis of disposal site stability." *Proceedings of Coastal Sediments '91*, ASCE, 2012-26.
- _____. (1992). "Dispersion analysis of Humboldt Bay, California, interim offshore disposal site," Miscellaneous Paper DRP-92-1, U.S. Army Engineer Waterways Experiment Station, Vicksburg, MS.
- _____. (1994). "Tidal constituent data base - East Coast, Gulf of Mexico, and Caribbean Sea," DRP Technical Note DRP-1-13, U.S. Army Engineer Waterways Experiment Station, Vicksburg, MS.
- Scheffner, N. W., and Borgman, L. E. (1992). "A stochastic time series representation of wave data," *Journal of Waterways, Ports, Coastal, and Ocean Engineering* 118(4).

- Scheffner, N. W., Mark, D. J., Blain, C. A., Westerink, J. J., and Luettich, R. A. (1994). "AADCIRC: An advanced three-dimensional circulation model for shelves, coasts, and estuaries; Report 5, Tropical storm database for the East and Gulf of Mexico Coasts of the United States," Technical Report DRP-92-6, U.S. Army Engineer Waterways Experiment Station, Vicksburg, MS.
- Scheffner, N. W., and Tallent, J. R. (1994). "Dispersion analysis of the Charleston, South Carolina, ocean dredged material disposal site," Miscellaneous Paper DRP-94-1, U.S. Army Engineer Waterways Experiment Station, Vicksburg, MS.
- Scheffner, et al. (1995). "LTFATE: A model to investigate the long-term fate and stability of dredged material disposal sites; User's guide," Dredging Research Program Instruction Report DRP-95-1, U.S. Army Engineer Waterways Experiment Station, Vicksburg, MS.
- Swart, D. H. (1976). "Predictive equations regarding coastal transports." *Proceedings of the 15th Coastal Engineering Conference*. ASCE, 1113-32.
- Teeter, A. M., and Pankow, W. (1989). "Schematic numerical modeling of harbor deepening effects on sedimentation, Charleston, SC," Miscellaneous Paper HL-89-7, U.S. Army Engineer Waterways Experiment Station, Vicksburg, MS.
- Westerink, J. J., Luettich, R. A., Jr., and Scheffner, N. W. (1993). "AADCIRC: An advanced three-dimensional circulation model for shelves, coasts, and estuaries; Report 3, Development of a tidal constituent database for the Western North Atlantic and Gulf of Mexico," Technical Report DRP-92-6, U.S. Army Engineer Waterways Experiment Station, Vicksburg, MS.
- White, P. (1972). "Sediment transport in channels: A general function," Report Int 104, Hydraulics Research Station, Wallingford, England.

Appendix G

Procedures for Conducting Frequency-of-Erosion Studies

Introduction

This appendix describes a procedure for determining frequency-of-occurrence relationships for vertical erosion (aka erosion frequency) of dredged material mounds off the Gulf and Atlantic coasts of the United States due to tropical and extratropical storms. The erosion frequency data can be used as a basis for computing the required thickness of the erosion layer portion of a contaminated dredged material mound cap. The design cap must be sufficiently thick to accommodate erosion from storm activity and still provide chemical and biological isolation. The primary goal of erosion frequency studies are therefore to develop information that can be used to determine (a) how thick a cap should be to provide sufficient protection and/or (b) at what depth must a mound with a given cap thickness be located to provide the same level of protection. Specific recommendations for erosion layer thickness design are contained in the body of this report. To make the erosion frequency discussion more easily understood, the procedures are illustrated in an example. The example used is an erosion frequency study done for the U.S. Army Engineer District, New York, as part of a site-capacity study for the Mud Dump disposal site located off Sandy Hook, NJ.

Numerical Models

The ability to effectively conduct erosion frequency studies has been made possible as a result of advances in modeling made by the Corps' Dredging Research Program (DRP) (Hales 1995).¹ The modeling advances were made in two areas. The first area was the development of an integrated hydrodynamic, sediment transport, and bathymetry change model, called Long-Term FATE of Dredged Material (LTFATE) model. This model is capable of modeling the

¹ References cited in this appendix are listed in the References at the end of the main text.

topographic evolution of dredged material mounds over time periods ranging from hours to centuries (Scheffner et al. 1995). A detailed description of LTFATE is found in Appendix F.

The second major modeling advance was the development of a series of databases containing the hydrodynamic driving force time series needed to run LTFATE - water levels and currents. Prior to the DRP, obtaining the hydrodynamic data to run LTFATE was a virtually impossible task because actual storm surge elevation and current data are unavailable except for a few recent storms at selected locations. The water level and current data needed for LTFATE required modeling tides and their associated currents and storm surges due to tropical and extratropical storms over a large area. To accomplish the modeling effort, the DRP funded the development of a state-of-the-art three-dimensional circulation model, called the advanced circulation model, or ADCIRC. A series of reports (Bain et al. 1994; Bain et al. 1995; Luettich, Westerink, and Scheffner 1992; Westerink, Luettich, and Scheffner 1993; and Westerink et al. 1994) describe the model, its development, and testing.

A primary application of ADCIRC for hydrodynamic input required by LTFATE was to compute tides and currents for the east and Gulf coasts. The 20,000 point grid over which ADCIRC computed surface elevations and currents is shown in Figure G1. A companion effort was to compute storm surge levels and the associated currents for 134 major tropical storms (hurricanes) on the east and Gulf coasts (Scheffner et al. 1994). A similar effort has also been conducted for extratropical storms. A comparable effort has been started for the West Coast (Luettich, Westerink, and Scheffner 1994), but the full suite of data needed for routine application of LTFATE for erosion-frequency studies on the West Coast and Great Lakes Coast are not yet available.

Wave data required as input to LTFATE are more readily available, both from gauges and from the Wave Information Studies (WIS) (Hubertz et al. 1994). The WIS series of reports provides hindcast wave heights, periods, and directions data at over one thousand coastal sites on all United States coasts for periods of 20 years or more. WIS wave data are provided at widely spaced (1 degree of latitude) deep-water sites and closely spaced locations (1/4 degree of latitude) in shallow water (typically about 10 m). Wave data can be accessed via a series of WIS reports, more recently electronically via the Coastal Engineering Data Retrieval System (CEDRS) available in Corps Coastal District offices (McAneny, in preparation), and the data are now available on the internet (ref).

Selecting the Proper Methodology for Determining Frequency-of-Occurrence Relationships

There are two methods that have been used by Corps' Districts in coastal design projects for computing frequency-of-occurrence relationships: (a) limited historical data and the selection of one or more "design storms" and/or

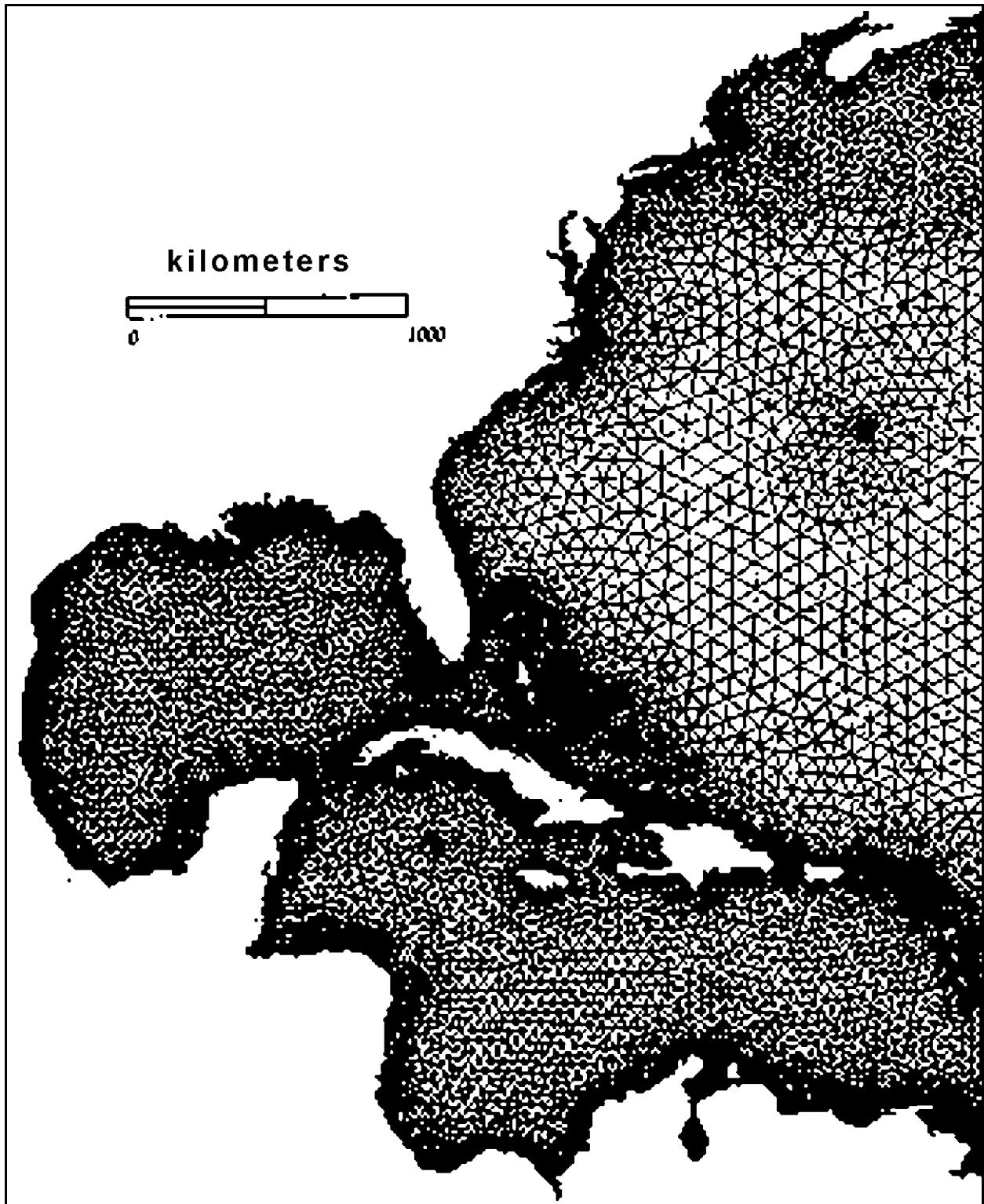

Figure G1. ADCIRC grid for computing surface elevations and currents

(b) application of the Joint Probability Method (JPM). The design storm approach basically involves selecting a severe historic storm event and using it to define a worst case scenario. The disadvantage of this method is that the frequency-of-occurrence of the design storm is usually not well known. Therefore the selected event may impose a more stringent cap design condition than necessary. Conversely, a worst case event may never have occurred at a specific location, and the design storm could lead to an overdesigned cap. In either case, the design storm event provides no information on frequency of occurrence and does not provide any error bands for use in design analysis.

The general JPM approach to assigning frequency relationships begins with parameterizing the storm that generated the effect of concern (e.g., wave height, surge level, bottom current). For hurricanes, descriptive parameters include maximum pressure deficit, maximum winds, radius to maximum winds, speed of translation, and track. The JPM is based on the assumption that the probability for each of the listed parameters can be modeled with empirical, or parametric, relationships. The joint probability of occurrence for a given effect, such as maximum surge, is defined as the probability of a particular storm event, computed as the product of the individual storm parameter probabilities via these assumed parametric relationships. This assumption is the primary basis of the JPM method used in past studies (Myers 1975).

However, the parameters that describe tropical storms are not independent, but are interrelated in some nonlinear sense (Ho et al. 1987). Because the parameters are not independent, joint probability cannot be computed as the product of individual parameter probabilities. Furthermore, it is generally recognized that extratropical storms cannot be effectively parameterized, so parametric probability relationships do not exist. Therefore, the JPM may not provide accurate approximations for tropical storms and is not appropriate for extratropical storms.

The empirical simulation technique (EST) is a statistical procedure for simulating nondeterministic multiparameter systems such as tropical and extratropical storms. The EST, which is an extension of the “bootstrap” statistical procedure (Efron 1982; Efron 1990), overcomes the JPM limitations by automatically incorporating the joint probability of the historical record. The bootstrap method on which EST is based incorporates resampling with replacement, interpolation based on a random walk nearest neighbor techniques with subsequent smoothing. More detailed descriptions of EST can be found in Scheffner, Borgman, and Mark (1993) and Borgman et al. (1992).

In EST, the various geometric and intensity parameters from storms are used to create a large artificial population (several centuries) of future storm activity (Borgman et al. 1992). The only assumption required for EST is that future storms will be statistically similar to past storms. Thus, the future storms generated during EST simulations resemble the past storms but possess sufficient variability to fill in the gaps in the historical data.

To perform the EST, historical storms impacting a site are broken down into the parameters that impact the engineering aspect of interest: storm track, maximum winds, radius to maximum, pressure deficit, etc. These variables are termed input vectors. The storm response of interest, in this case vertical erosion of the capped mound, is also calculated for each historical storm using an appropriate model (in this case LTFATE is used). The response of interest is referred to as response vector. During EST simulations, N-repetitions (say 100 or more) of T-year responses (say 100 to 200 years) of the response vector of interest (vertical erosion for capping projects) are produced providing mean value frequency relationships with accompanying confidence limits such that probability of occurrence can be defined with error band estimates. In other words, the mean vertical erosion for a range of return intervals with confidence limits (based on the number of standard deviations) are produced by the EST procedure.

There have been a number of applications of the bootstrap method and EST to coastal problems. Prater et al. (1985) described error estimation in coastal stage frequency curves for Long Island. Mark and Scheffner (1993) discuss use of the EST to compute frequency of occurrence of storm surge elevations in Delaware Bay. Farrar et al. (1994) describe the use of EST to estimate the frequency of horizontal beach erosion as part of an economic analysis for design of beach fills at Panama City, FL. Most recently, the EST technique was used to predict frequency of vertical erosion estimates for capped mounds at a range of depths at the Mud Dump disposal site located east of Sandy Hook, NJ (Clausner et al. 1996). The work was part of a larger effort for the New York District to determine remaining capacity of the Mud Dump site for both suitable sediments and those requiring capping.

Application of the EST to a capping project involves a series of sequential steps to calculate the cap erosion thickness, which are described in the remainder of this appendix.

Recommended Erosion Frequency Procedure

To define the required cap erosion layer thickness as a function of depth at a specific site, first the erosion frequency must be determined. It consists of a site-specific quantitative analysis approach that requires the completion of several sequential tasks. These tasks are (a) selection of appropriate storm events, (b) development of storm surge elevation and current hydrographs for each event, (c) development of four tidal phase elevation and current hydrographs, (d) development of a wave height and period time series corresponding to each storm event, (e) generation of input files representing the combination of tasks 2-4 to the Long-Term Fate of Dredged Material (LTFATE) model used to predict erosion, (f) execution of the LTFATE model to determine maximum vertical erosion at the site as a result of each of the storm events, (g) development of input files for the Empirical Simulation Technique (EST) program to generate multiple repetitions of storm-event activity and the corresponding vertical erosion, and finally, (h) using the EST program to generate vertical erosion

frequency relationships (with error band estimates) for a particular disposal mound configuration.

Detailed descriptions of how each of the above tasks of an erosion frequency study should be conducted follow some background information on the Mud Dump case study example.

Mud Dump Disposal Site Study - Background Information

The frequency-of-occurrence methods described are illustrated in their application to concerns over erosion of capped mounds at the Mud Dump disposal site, the designated dredged material open-water disposal site for the Port of New York and New Jersey (PNY/NJ). Critical to the management of dredged material removed from the PNY/NJ is the remaining capacity within the Mud Dump site. The above procedures were developed to assist in determining the minimum water depths in which capped mounds can be placed without experiencing unacceptable amounts of erosion and therefore directly influence the ultimate capacity of the Mud Dump site to contain contaminated dredged material.

At the time this appendix was written (1996), the Mud Dump disposal site was virtually the only authorized site for open-water placement of dredged material from the PNY/NJ. The site is a 1.12 by 2 n mile rectangle located approximately 6 n miles east of Sandy Hook, NJ (Figure G2), in an area known as the New York Bight. Water depths at the site range from less than 50 ft to over 90 ft. As of October 1994, up to 65 M yd³ of dredged material (based on scow logs) had been placed in the site. Because the Mud Dump site was the only available disposal site for fine-grained dredged material from the PNY/NJ, the remaining capacity was an extremely important issue in the overall plan for managing dredging and disposal for the Port. Because of the large volume of contaminated material inside the port, the remaining capacity of the Mud Dump site for Category II (requiring special handling, i.e., capping for open-water placement) dredged material (USACE/USEPA 1991) was critical in the sediment management process for the New York District and the PNY/NJ.

At the request of the New York District, the U.S. Army Engineer Waterways Experiment Station's Coastal Engineering Research Center (CERC) conducted a study to define Mud Dump site capacity and other issues related to capping (Clausner, Scheffner, and Allison 1995). Studies to compute the vertical erosion frequency for mounds of various elevations in the Mud Dump site were the most critical part of this effort. Previous studies have shown erosion of fine-grained materials from mound flanks as a result of severe northeasters (McDowell 1993; McDowell, May, and Pabst 1994). At the request of the New York District, mounds with cap elevations ranging from 50 to 75 ft were modeled, with ambient depths of 60 to 83 ft.

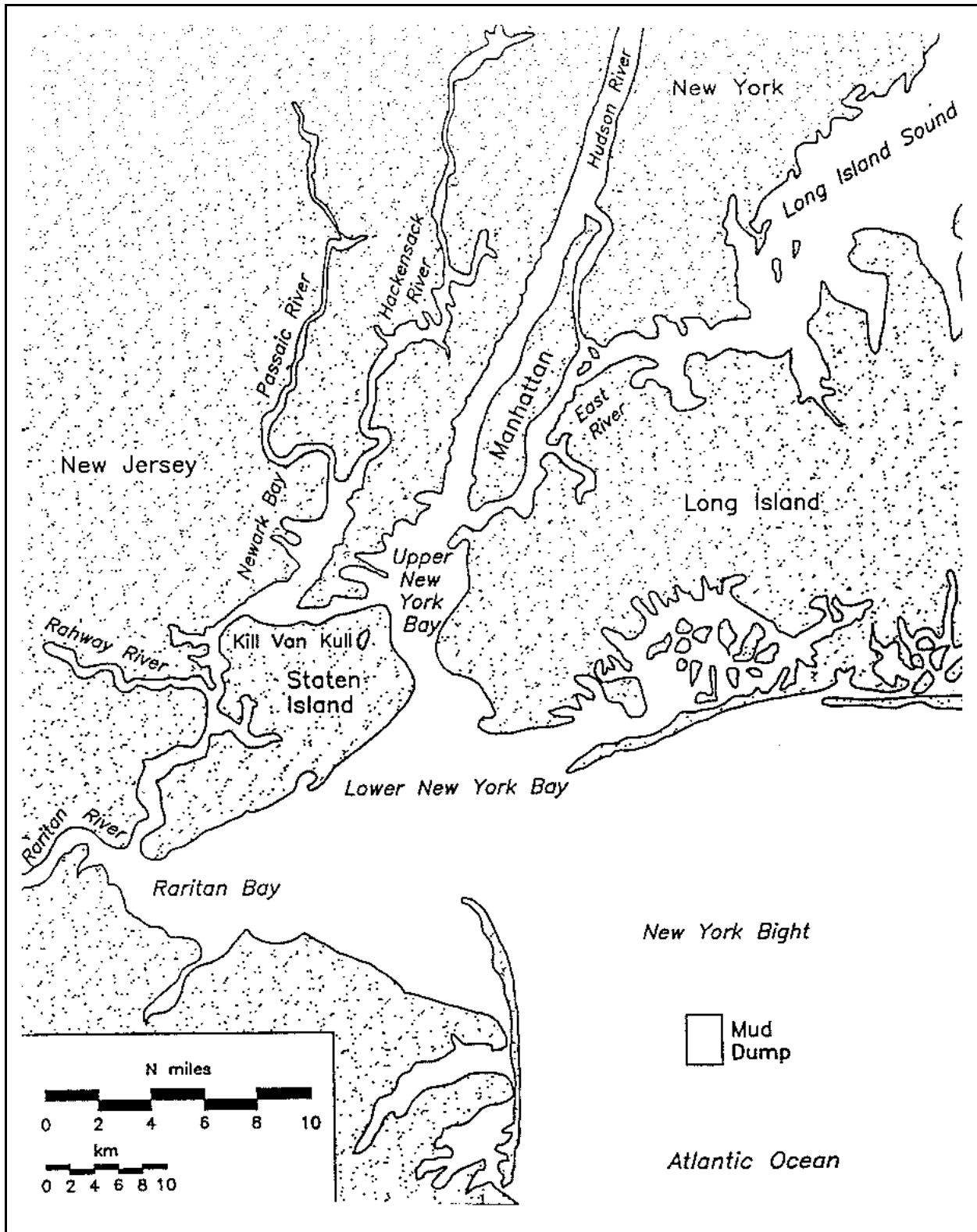

Figure G2. Mud Dump disposal site location map

Storm Selection

The first step in a frequency-of-erosion study is to identify storms that have impacted the site of interest. For sites on the east coast, particularly the northeast coast, both tropical storms (hurricanes) and extratropical storms (northeasters) have to be included. While the tropical storms often have higher winds, the longer duration of the extratropical storms allows them to produce vertical erosion of equal or greater magnitude than hurricanes. Also, northeasters occur much more frequently than hurricanes. For sites on the Gulf coast, northeasters will generally not be a major problem; hurricanes will most likely be the only storms of concern.

Tropical storm selection

The tropical storm database of the National Hurricane Center's HURricane DAT (HURDAT) database (Jarvinen, Neuman, and Davis 1988) is the recommended source of historical events that have impacted the east and Gulf coasts (and therefore the Mud Dump site). The tropical storm database generated by the DRP (Scheffner et al. 1994) contains an atlas of 134 storm events, as well as their respective tracks, that impacted the east and Gulf coasts of the United States. The database contains maximum computed storm surge elevations at up to 486 discrete locations impacted by each event according to the criteria that (a) the minimum pressure of the storm was less than or equal to 995 mb, (b) the eye of the storm passed within 200 statute miles of the location of interest (the Mud Dump site in this application), and (c) the storm generated a surge of at least 1 ft above mean sea level (MSL). The published atlas in Scheffner et al. (1994) tabulates maximum storm surges that have impacted each station and the respective storm events responsible for that surge. Cross-referencing is also provided to show which stations were impacted by each of the 134 events and the respective maximum surge at those stations.

This dual tabulation should be used to identify potential storms impacting the site of interest, the Mud Dump site in this example. Elevation and current hydrographs corresponding to each event and impacted location are available from the DRP database.

The DRP tropical storm database was constructed by simulating the 134 historically based storm events as they propagated over the east coast, Gulf of Mexico, and Caribbean Sea computational domain shown in Figure G1 using the numerical hydrodynamic model ADCIRC described earlier. The DRP database of storm-surge hydrographs and currents was archived at 240 east and Gulf coast Wave Information Study (WIS) stations (Hubertz et al. 1993) with additional locations prescribed for Puerto Rico. To use the DRP tropical storm database information, the WIS station nearest the disposal site of interest is selected. WIS Station 304 (DRP numbering system) is nearest to the Mud Dump site; therefore, storm events impacting this station were selected for the frequency analysis (Figure G3). Station 304 has a depth of approximately 108 ft.

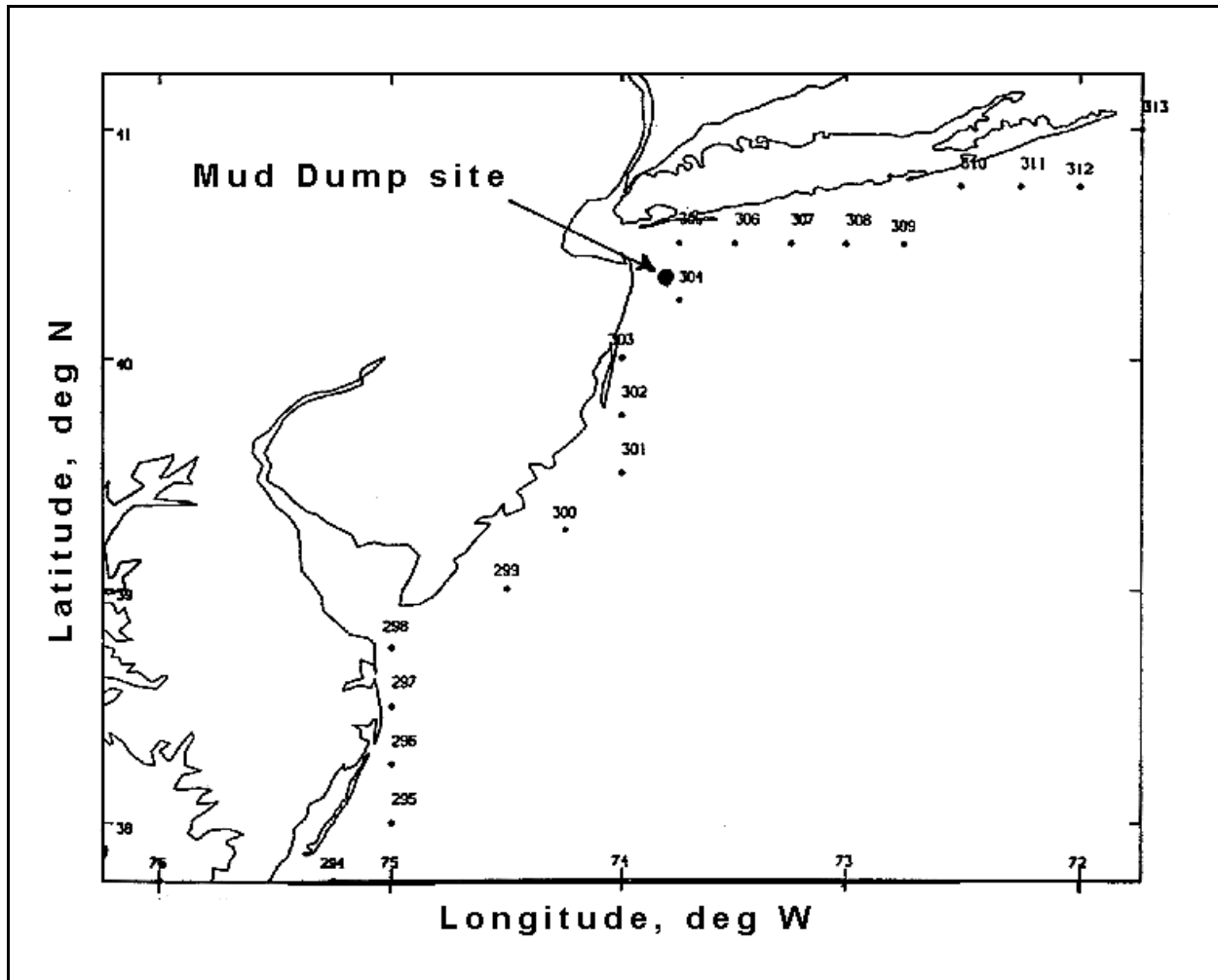

Figure G3. Map showing WIS locations relative to the Mud Dump site

To convert the surge current values from the database location to the disposal site, the mean depth at the two locations is determined. The surge current values should then be assumed to be proportional to the relative depths at the two sites. A mean depth for the Mud Dump site was determined to be approximately 83 ft; therefore, the DRP-generated surge current hydrographs were adjusted according to the criteria that $Q=VA=Const$; therefore, $V_{Mud} = V_{304} * 108/83$.

Sixteen tropical storm events were retrieved from the DRP archives that impacted the location of DRP Station 304 (Mud Dump site) according to the criteria described above. Sixteen tropical storm events in 104 years of record correspond to an annual frequency-of-occurrence of 0.15385 events per year (or one event every 6.5 years). These events are shown in Table G1.

Table G1 Tropical Events Impacting Mud Dump Site		
HURDAT Storm No.	Given Name	Date (month/day/year)
296	Not Named	9/22/1929
327	Not Named	8/17/1933
332	Not Named	9/8/1933
353	Not Named	8/29/1935
370	Not Named	9/8/1936
386	Not Named	9/10/1938
436	Not Named	9/9/1944
535	Carol	8/25/1954
541	Hazel	10/5/1954
545	Connie	8/3/1955
597	Donna	8/29/1960
657	Doria	9/8/1967
702	Doria	8/20/1971
712	Agnes	6/14/1972
748	Belle	8/6/1976
835	Gloria	9/16/1985

Extratropical storm event selection

Extratropical events occur at a much greater frequency than tropical events. As a result, a shorter historical time period can be used to represent the range of events that can be expected to impact a particular area. For the extratropical event analysis, approximately 15 to 20 years of winter activity were determined to contain an adequate representation of extratropical events¹ for any area along the east coast of the United States. The 16 winter seasons (September through March) for the period of 1977-78, 1978-79, ... , 1992-93 were selected as the time period for which the DRP extratropical storm database was generated. This time period was selected because it corresponds to dates when the Navy wind-field database containing the extratropical winds was available in an ADCIRC-compatible format. The DRP database was then used as the basis for the extratropical frequency analysis described in this appendix.

The DRP extratropical storm database was also constructed by using the ADCIRC numerical hydrodynamic model to simulate all 16 winter seasons over the entire computational domain shown in Figure G1. The U.S. Navy's windfield

¹ Personal Communication, 1994, L. E. Borgman, Professor, University of Wyoming, Laramie, WY.

database, which is archived at every 2.5 degrees of latitude and longitude at a temporal period of 6 hr, was used as input to ADCIRC. The 16 winter season (September-March) input files were prepared by archiving the data within the area of 100° - 60° west longitude and 5° - 50° north latitude, which encompasses the east coast, Gulf of Mexico, and Caribbean Sea as part of ADCIRC's 20,000-node computational grid.

ADCIRC-generated surface elevation and current hydrographs for each 7-month period were archived at 686 locations at a sampling period of 1 hr. Of the 686 stations, 340 correspond to locations (WIS) stations. As for the tropical storms, extratropical storms impacting WIS Station 304 were selected for the frequency analysis.

Storm-Surge Hydrograph Development

Tropical storms

Once identified, the selected tropical storms are retrieved from the DRP database. However, each hydrograph represents the entire storm history, from beginning to end, often a week or more in duration. Because only the erosional effect of the event on the site being studied are of interest, each hydrograph was constructed at a time step of 3 hr to be 99 hr in duration, measured as 48 hr before the well-defined 3-hr duration peak and 48 hr after the peak, for example see Figure G4. The time of peak is selected as the time when the eye of the storm is closest site of interest.

Extratropical storms

For the extratropical storms, the storm event time periods of impact will not be well defined at many locations, including the Mud Dump site. Examination of surge elevation, current magnitude and wave height, and period records from the Mud Dump site did not allow extratropical storms and their duration to be readily identified.

One reason for this difficulty in identifying extratropical storms is the fact that the surge currents accompanying each event are generally relatively small (i.e., on the order of 20-30 cm/sec at the Mud Dump site), and their effects have to be considered with respect to other environmental factors occurring at the time of the storm. These factors include the local depth, the orbital velocities of the wave field, the duration of the event, and the phase of the tide. Therefore, to isolate significant events from the 7-month record, a more quantitative approach to event parameterization is recommended and was developed for the Mud Dump study. This second order parameterization approach is defined following the descriptions of tide and wave field data accompanying the hydrodynamic surge and current response.

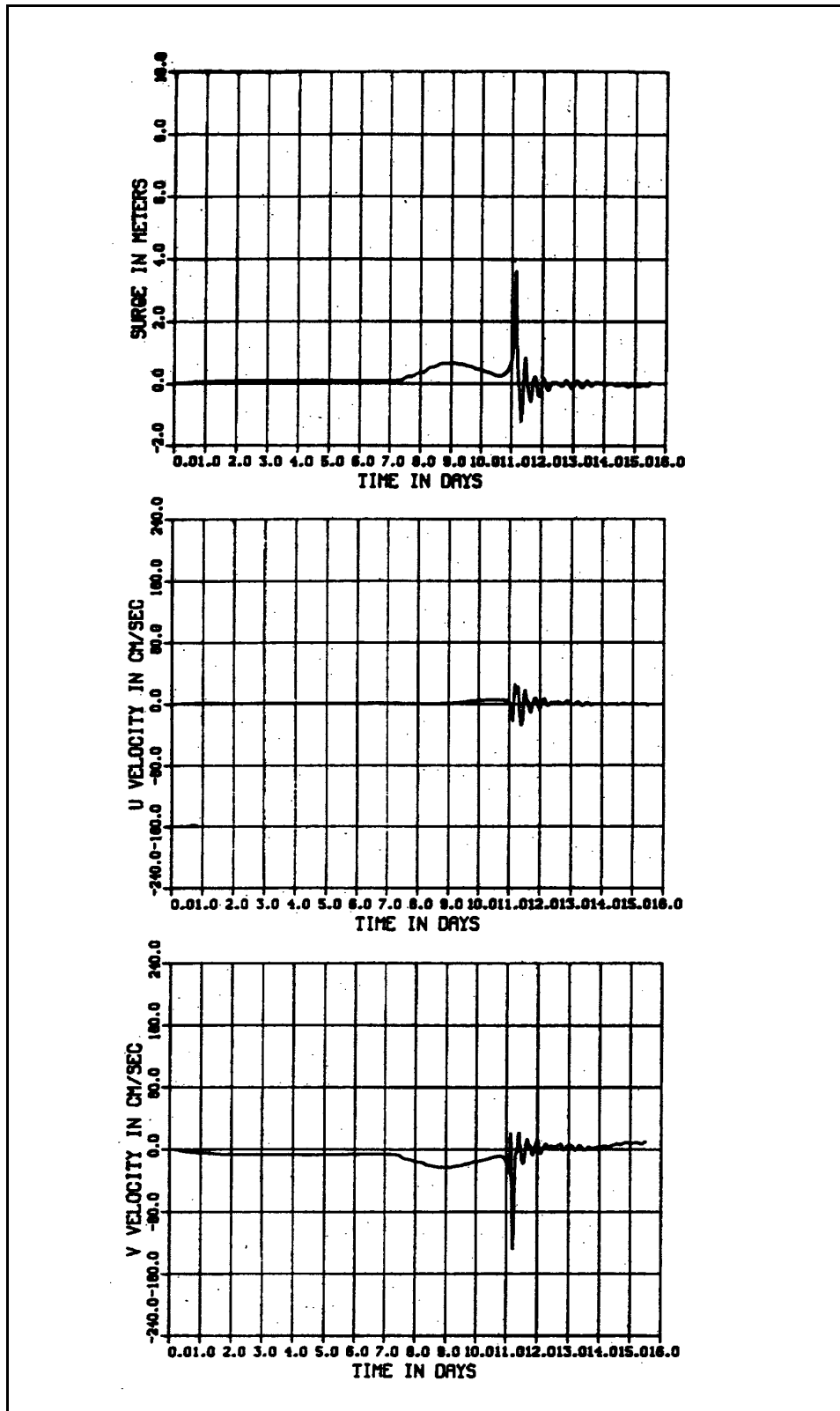

Figure G4. Surge elevation and current hydrograph for Hurricane Gloria, without tides

Tidal Hydrograph Development

The surge hydrographs corresponding to the tropical and 1977-1993 extra-tropical storm seasons were simulated over the domain shown in Figure G1; however, simulations did not include tides at the time of the event, i.e., they were modeled with respect to MSL. Because tide elevation and currents will be a factor in mound erosion, they must be included. When tidal phase is accounted for, each storm event has an equal probability of occurring at (a) high tide, (b) MSL during peak flood, (c) low tide, and (d) MSL during peak ebb. These four phases are designated as phases 0, 90, 180, and 270 degrees, respectively.

Obtaining the needed tidal elevation and current data can most effectively be accomplished by using the DRP-generated 8-constituent (4 primary semidiurnal and 4 diurnal) database of tidal constituents corresponding to each node shown in Figure G1 (Westerink, Luettich, and Scheffner 1993). This effort also made use of the ADCIRC program. A linear interpolation scheme (described in the report) uses this database to provide tidal constituents at any location within the domain. At the Mud Dump site the M_2 semidiurnal tidal constituent accounts for over 90 percent of the tidal energy (based on the 8-constituent database) as can be seen in the listing of constituent amplitude and local epochs k generated for DRP-WIS Station 304 shown in Table G2. (Constituents were generated at Station 304 instead of the Mud Dump site in order for the tide to correspond to the hydrographs archived at Station 304).

Const	h-amp, m	h-k, deg	U-amp, cm/sec	U-k, deg	V-amp, cm/sec	V-k, deg
k_1	0.0867	95.2	0.0049	194.3	0.0061	27.1
O_1	0.0589	100.4	0.0028	193.3	0.0042	43.5
P_1	0.0359	91.0	0.0020	193.5	0.0028	19.7
Q_1	0.0111	98.3	0.0006	202.4	0.0007	19.2
N_2	0.1704	195.6	0.0181	295.6	0.0226	116.0
M_2	0.7744	215.3	0.0837	313.8	0.1012	133.8
S_2	0.1507	254.6	0.0169	355.4	0.0213	173.4
K_2	0.0482	246.6	0.0054	347.2	0.0068	164.9

To account for the four tidal phases, M_2 amplitude A and local epoch phase data k for elevation ($h = 0.7744$ m, $k = 215.3^\circ$) and current ($U: A = 0.0837$ m/sec, $k = 313.8^\circ$; $V: A = 0.1012$ m/sec, $k = 133.8^\circ$) were extracted from the DRP database and used to expand the 16 tropical storms and 16 extratropical season database of storms without tides to a 64 tropical storm database with tides and a 64 extratropical season database with tides. This expanded set of

hydrographs represents a combination of the surge hydrograph with the tidal hydrographs generated for the four phases of the tide based on the M_2 tidal constituent.

Wave Field Hydrograph Development

Waves are a critical component of LTFATE input. This section recommends procedures for providing input waves for both tropical and extratropical storms.

Tropical storms

Because LTFATE does not have a storm wave field component, a methodology was adopted from the Shore Protection Manual (SPM) (Headquarters, Department of the Army 1984). The approximation reported in the SPM gives an estimate of the deepwater significant wave height and period at the point of maximum wind for a slowly moving hurricane. A full numerical hindcast of the wave field associated with the historical event would be more accurate than the adopted procedure; however, the SPM approach is expected to be adequate for the purposes of most erosion frequency studies.

The wave height and period are given by the following formulae:

$$H_o = 16.5 e^{\frac{R\Delta p}{100}} \left[1 + \frac{0.208\alpha V_F}{\sqrt{U_R}} \right] \quad (G1)$$

and

$$T_s = 8.6 e^{\frac{R\Delta p}{200}} \left[1 + \frac{0.104\alpha V_F}{\sqrt{U_R}} \right] \quad (G2)$$

where

H_o = deepwater significant wave height in feet

T_s = corresponding significant wave period in seconds

R = radius to maximum wind in nautical miles

$Dp = p_n - p_o$, where p_n is the normal pressure of 29.93 in. of mercury and p_o is the central pressure of the hurricane

V_F = forward speed of the hurricane in knots

U_R = maximum sustained windspeed in knots calculated 33 feet above MSL at radius R

α = a coefficient depending on the speed of the hurricane. The suggested value is 1.0 for a slowly moving hurricane

All of the above variables used in Equations G1 and G2 are contained in or can be calculated from the HURDAT database.

Given a maximum wave height and period, a wave field time series for tropical storms was calculated through the following expansion:

$$[H(t), T(t)] = [H_o, T_s] e^{\left(\frac{-9.21}{D}\right)^2 \left(t - \frac{D}{2}\right)^2} \quad (G3)$$

where

t = time in hours starting 51 hr before peak surge (at hour 51) and extending 48 hr after peak surge

D = significant duration of the surge, taken as 24 hr

Given a maximum wave height and period, a wave field time series should be calculated starting 51 hr before peak surge (at hour 51) and extending 48 hr after peak surge. Wave heights and periods described by Equation G3 decay to zero; therefore, minimum values must be prescribed for the time series. These minimum values were specified based on summary tables provided by WIS (Hubertz et al. 1993) for the WIS station location cited in this report (WIS Station 72, which corresponds to DRP #304). The average direction of travel for the 16 tropical events was computed to be approximately 11° clockwise from true north (an azimuth of 191° by WIS convention). According to Hubertz et al. (1993), the largest number of waves at an azimuth of 180° were in the 5.0-6.9 sec band. Therefore, a minimum period of 6.0 sec was selected for the storm-event hydrographs. Maximum mean wave conditions for the months of September and October were reported to be 1.2 and 1.3 m, respectively; therefore, a minimum wave condition was selected to be 1.25 m. Finally, maximum wave heights were limited to the breaking wave criteria of $H_b = 0.65 \cdot \text{depth}$ based on measurements indicating that storm-generated waves in open water are limited to approximately 0.6-0.7 times the local depth (Resio 1994). Scenarios, to be described below, included mound configurations located at three depths, the minimum of which was 63.0 ft. In order to prescribe wave field boundary conditions that are consistent for all simulations, the minimum depth was used to define maximum wave criteria. Therefore, maximum allowable waves were limited to $0.65 \cdot 63.0 = 40.95 \text{ ft} = 12.48 \text{ m}$. This criteria should be used for all simulation scenarios.

Extratropical storms

The wave field input for the extratropical database of events should normally be extracted from the WIS hindcast database unless site-specific wave data from a gauge are available. For the Mud Dump study, the wave field was extracted from the WIS hindcast database for the periods of time corresponding to each of the 1977-1993 storm seasons. These data, available at a 3-hr time step, were obtained from the WIS database and combined with the storm surge elevation and current and tidal elevation and current databases. All hydrographs were generated at a 3-hr time step to be compatible with the WIS database and input requirements of the LTFATE model.

Extratropical Storm Identification

As stated above, first order parameters such as surge elevation and currents or wave heights and periods did not immediately isolate specific extratropical storm events of interest for the Mud Dump site. For example, Figure G5 shows the WIS wave height and period time series for the 1977-79 extratropical storm season. The surface elevation and U,V current hydrographs are similar, i.e., specific storms are difficult to identify. This conclusion is in agreement with the recognized observation that extratropical events are not conducive to parameterization.¹ Because it is not feasible to model the entire season with LTFATE to determine which events impact the Mud Dump site (this would require days on a PC running at 100 MHz), a procedure had to be developed to isolate events of interest.

Developing a systematic procedure to identify and subsequently separate significant storm events from the extratropical storm database required an analysis of combinations of individual parameter components that may provide an indication of impact to east coast sites. Because the storm effect of interest for this example is vertical erosion of a disposal mound located at the Mud Dump site, a methodology for identifying storms with measurable erosional impact was developed by combining available storm-event information into a second order parameter, one which represents some combination of first order parameters such as surge, tide, wave height, etc. This parameter was chosen to be the instantaneous sediment transport magnitude, computed as a function of the storm-induced surge elevation and current, the maximum M_2 tidal amplitude and maximum M_2 tidal velocity magnitude, and the wave height and period.

The transport relationship used is based on the Ackers-White (1973) equations with a modification for additional energy provided by waves suggested by Bijker (1971) used in the LTFATE model. The result of the computation is a transport magnitude hydrograph computed as a function of surge, tide, and wave climate. For the Mud Dump site example, the mean depth was specified as 83 ft

¹ Personal Communication, 1994, L. E. Borgman, Professor, University of Wyoming, Laramie, WY.

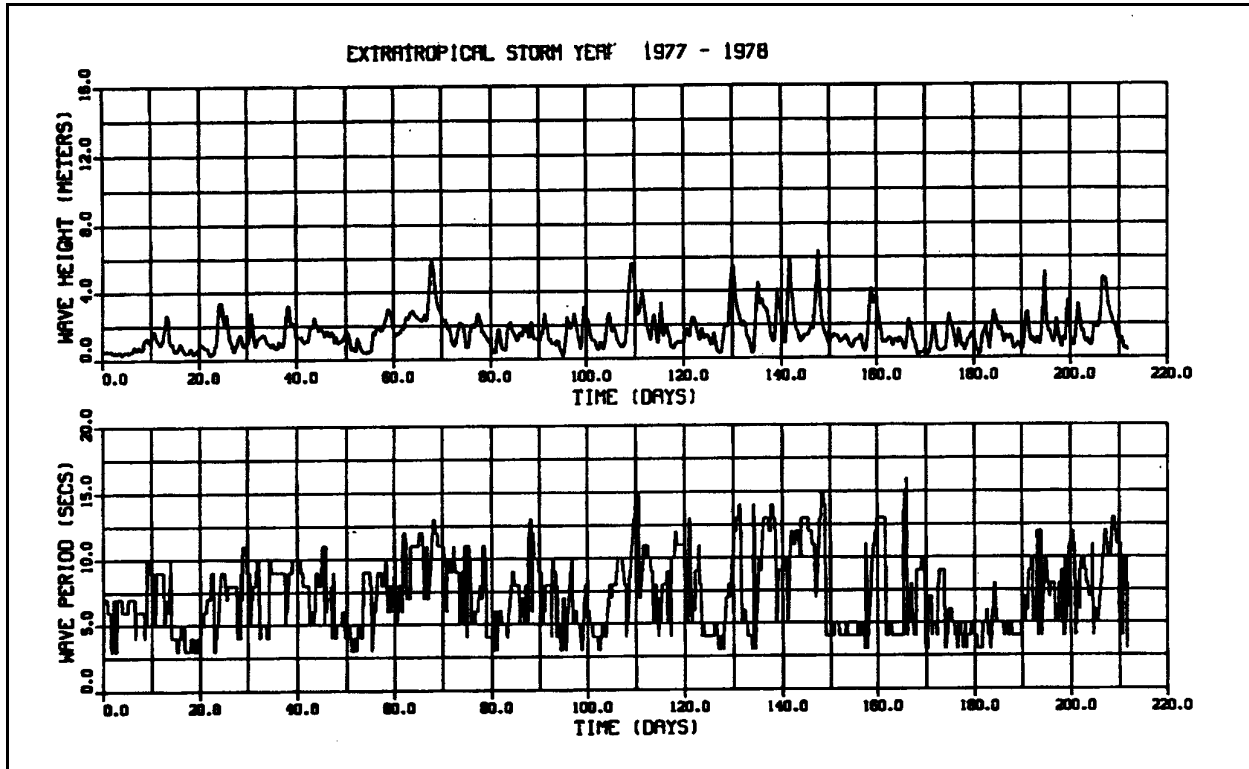

Figure G5. WIS wave height and period time series for 1977-78 extratropical storm season

and mean grain size set at 0.40 mm. The 83 ft depth was the base depth area within the Mud Dump site considered for capping; 0.40 mm sand was the suggested cap material.

The sediment transport hydrograph for the 1977-78 storm season is shown in Figure G6. As evident in the figure, distinct events are now clearly visible in the time series. This approach to event identification is in contrast to the first order parameter time series shown in Figure G5.

Analysis of the 16 seasonal transport hydrographs resulted in the adoption of a threshold value of 30.0×10^{-4} ft³/sec/ft-width as the basis for selecting events that may cause erosion to the Mud Dump site. This value, selected by trial and error through application of the LTFATE model, will produce a maximum of 0.25 ft of vertical erosion per 24 hr at the corner of mound cap measuring 100 by 100 ft. Table G3 presents a summary of the analysis for the 1977-1993 storm years in the form of the approximate day (measured from 1 September) of occurrence and the magnitude of the peak transport value. The total number of events per season is also tabulated. According to this criteria, the computed average number of events per year that impact the Mud Dump site is 38 events/16 seasons = 2.375 events/year.

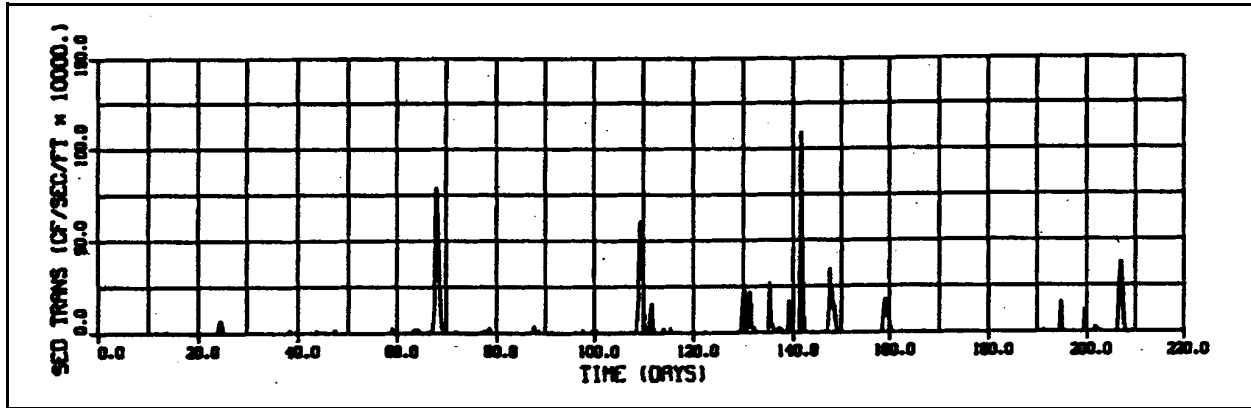

Figure G6. Sediment transport hydrograph for the 1977-78 storm season

Table G3 Summary of Storm Events by Day of Season/Maximum Transport Magnitude in $\text{ft}^3/\text{sec}/\text{ft-width} \times 10^{-4}$						
Year	1	2	3	4	5	Total
77-78	68/80	110/65	142/110	207/35	--	4
78-79	146/190	171/50	193/50	205/50	--	4
79-80	132/35	138/35	195/50	--	--	3
80-81	55/125	154/70	163/105	210/30	--	4
81-82	--	--	--	--	--	0
82-83	55/70	164/50	199/50	--	--	3
83-84	41/35	102/110	180/45	210/165	--	4
84-85	43/85	165/180	--	--	--	2
85-86	27/160	65/125	160/30	191/30	200/70	5
86-87	93/190	115/40	123/40	--	--	3
87-88	--	--	--	--	--	0
88-89	--	--	--	--	--	0
89-90	49/33	--	--	--	--	1
90-91	--	--	--	--	--	0
91-92	126/40	--	--	--	--	1
92-93	101/150	165/30	185/120	194/155	--	4

The purpose of selecting specific storms is ultimately to determine frequency-of-occurrence relationships. The specific effect of interest will clearly have a direct bearing on the selection of appropriate storm events. For example, the 10 storm events that cause the most shoreline erosion at a particular location are not necessarily the same 10 events that cause the most vertical erosion of a

capped mound in the same area. A separate storm analysis would be required to identify events that cause shoreline/dune recession. However, this second-order parameter approach to storm isolation has been found to be successful in identifying events that cause erosion to a disposal mound. By defining the appropriate parameter, the approach is equally applicable to shoreline processes analyses.

Because vertical erosion is the impact of interest, the transport hydrographs (Figure G6 for 1977-78) were used to identify 38 specific events with a peak transport magnitude greater than the threshold value of $30.0 \times 10^{-4} \text{ ft}^3/\text{sec}/\text{ft}$ -width at the Mud Dump site. These events are listed in Table G3. For each event, surge, tidal, and wave field time series were extracted from the seasonal summary tables to generate hydrographs of total water surface elevation (storm plus tide), total U and V current (storm plus tide), and wave height and period. Each of the 152 hydrographs (38 events with 4 tidal phases) was constructed to be 6 days in duration, centered on the day indicated in Table G3. These hydrographs represent input to the LTFATE model.

LTFATE Model Simulations

After the selected storms have been identified, LTFATE simulations should be used to determine the maximum amount of vertical erosion resulting from each storm for each of the disposal site configurations of interest. As noted earlier, for the Mud Dump site, six combinations of ambient depth, mound height, and crest depth were tested (Table G4). All mound configurations had side slopes of 1:50 with the cap material specified to be noncohesive sand with a d_{50} of 0.40 mm.

Test Number	Ambient Depth, ft	Mound Height, ft	Crest Depth, ft
1	63	13	50
2	63	8	55
3	73	13	60
4	73	8	65
5	83	13	70
6	83	8	75

LTFATE input file generation

The surge, tidal, and wave field time series must be placed into a format compatible with LTFATE. An example LTFATE input file for hurricane #835 is shown in Table G5. For the Mud Dump study, storm-event input files

Table G5 Example LTFATE Input File					
Hurricane: 835 WIS Station: 304	Wave Height, m	Wave Period sec	U-cm/sec	V-cm/sec	Surge, m
219.00	1.250	6.000	9.251	-38.308	1.164
222.00	1.250	6.000	11.406	-39.243	0.071
225.00	1.250	6.000	-3.124	-20.060	0.049
228.00	1.250	6.000	-5.420	-15.662	1.071
231.00	1.250	6.000	9.419	-30.920	1.172
234.00	1.250	6.000	15.334	-35.614	0.077
237.00	1.250	6.000	1.519	-16.542	-0.207
240.00	1.250	6.000	-4.056	-7.843	0.794
243.00	1.250	6.000	9.616	-22.601	1.095
246.00	1.250	6.000	17.646	-30.015	0.074
249.00	1.250	6.000	5.436	-13.767	-0.424
252.00	1.250	6.000	-3.789	-0.846	0.462
255.00	1.748	6.000	7.207	-12.689	1.008
258.00	4.787	6.000	17.136	-24.358	0.165
261.00	9.829	9.460	6.573	-13.044	-0.361
264.00	12.485	14.567	-7.198	-8.491	0.750
267.00	12.485	15.433	-31.538	20.684	3.775
270.00	12.485	14.567	30.319	-121.682	0.077
273.00	9.829	9.460	-28.224	13.077	-1.510
276.00	4.787	6.000	6.797	-4.497	0.262
279.00	1.748	6.000	-0.205	8.166	0.201
282.00	1.250	6.000	5.546	-6.199	0.412
285.00	1.250	6.000	13.366	-12.180	-1.050
288.00	1.250	6.000	-18.947	27.948	-0.298
291.00	1.250	6.000	2.285	1.164	0.663
294.00	1.250	6.000	5.566	-1.685	0.223
297.00	1.250	6.000	9.583	-6.201	-0.647
300.00	1.250	6.000	-6.529	13.946	-0.438
303.00	1.250	6.000	-4.978	15.048	0.544
306.00	1.250	6.000	7.271	0.057	0.589
309.00	1.250	6.000	13.559	-10.128	-0.625
312.00	1.250	6.000	-7.279	14.726	-0.672
315.00	1.250	6.000	-9.291	15.761	0.606

representing the 99-hr time sequences for each of the 16 tropical storm events and the 144-hr time sequences for each of the 38 extratropical storm events were input to LTFATE.

Model simulations

The six Mud Dump ambient depth/mound height combinations were subjected to the 64 tropical storm surge hydrographs (16 storms times four possible tide phases) to evaluate the erosion potential of the configurations shown in Table G4. An identical procedure was followed for the 152 extratropical storm surge hydrographs (38 storms times four possible tide phases). In all six simulations for each type of storm, the maximum vertical erosion experienced at any location on the mound during each of the simulations was archived for use in the EST to develop vertical erosion versus frequency-of-occurrence relationships.

EST Input File Development

As noted earlier, EST is a statistical procedure that uses a limited database of historical occurrences to generate multiple simulated scenarios from which frequency relationships and error estimates can be computed. The EST requires two types of input. The first set represents descriptive storm parameters that define the dynamics of each storm event. These parameters, referred to as input vectors, should be (a) tidal phase, (b) duration of the event measured as the number of hours during which the computed transport magnitude exceeds 10.0×10^{-4} ft³/sec/ft-width, (c) maximum transport magnitude computed during the storm event, (d) wave height, (e) wave period, and (f) maximum depth-averaged velocity magnitude associated with the maximum transport value.

The second input parameter represents a measure of damage resulting from the passage of the storm event. These parameters are referred to as response vectors. Typical response vectors are storm surge elevation, shoreline erosion, dune recession, flood inundation, or for capping projects, vertical erosion.

Tropical storm vectors

Input and response vectors for hurricanes #296, 327, 748, and 835 for high water after flood (maximum tidal surface elevation) for the site scenario of an 8-ft mound located in 83 ft of water are shown in Table G6.

The EST uses the parameters of Table G6 for all tropical storm events and each of the four tidal phases as a basis for simulating multiple repetitions of multiple years of storm activity. In this application, 100 repetitions of a 200-year sequence of storm activity were simulated for the six scenarios shown in Table G6. As mentioned above, the EST assumes that future storm activity will be similar to past events, i.e., a hurricane such as Camille, which devastated the

Table G6 Tropical Storm Input and Response Vectors for the Mud Dump Site								
Hurr. No.	Tide Phase 0-1	Min. Dist. miles	Track Angle deg	Pres. Def., mb	Max. Vel. knots	Forw. Vel. knots	Rad. Max. nm	Vert. Eros., ft
296	1.0	84.85	29.35	25.83	30.68	18.39	43.42	0.20
327	1.0	172.3	10.41	35.31	45.00	20.19	43.42	0.20
748	1.0	17.45	13.46	32.19	67.53	21.81	8.68	0.10
835	1.0	11.32	20.59	56.97	82.04	37.89	36.93	0.80

Gulf coast in 1969, cannot occur in the Bight because historical records indicate that storms of this magnitude have not impacted the Bight. This is probably due to both the exposure of the Bight and the northerly latitude. The second assumption is that the frequency of events is similar to historic activity. In the New York Bight, the frequency used is 16 events per 104 years, i.e., frequency = 0.15385.

Extratropical storm vectors

Input and response vectors for the four events of the 1977-78 extratropical storm season for the zero tidal phase for the site scenario of an 8-ft mound located in 83 ft of water are shown in Table G7.

Table G7 Extratropical Storm Input and Response Vectors for Mud Dump Site							
Storm No.	Tidal pH-deg	Dur, hr	Q-Max	H, m	T,sec	V-Max cm/s	E-Max, ft
1	0	21	68.9	5.9	12.0	51.8	0.20
2	0	21	57.6	5.6	12.0	50.8	0.20
3	0	18	50.4	5.6	10.0	51.8	0.20
4	0	15	35.3	4.7	12.0	49.5	0.10

In an identical procedure to the tropical storm simulations, the EST uses the input and response vectors of Table G7 for the selected extratropical storm events and for each of the four tidal phases as a basis for simulating multiple repetitions of multiple years of storm activity. As mentioned above, the EST assumes that future storm activity will be similar to past events. In the New York Bight, the frequency used is 38 events per 16 years, i.e., frequency = 2.375 storms/year.

The EST program generates a 200-year tabulation consisting of the number of storm events that occurred each year and the vertical erosion corresponding to

each event. To define an erosion magnitude consistent with the tropical storm analysis, the total summation of erosion magnitudes per year was selected as the parameter of interest. For example, if three storm events were simulated during the first year, the sum of the three vertical erosions would be used to define the parameter for which frequency-of-occurrence relationships would be computed. The computational process is described in the following section.

EST simulation results - vertical erosion versus frequency-of-occurrence

To most effectively use the results from the EST simulations for cap erosion layer thickness design, frequency of vertical erosion curves and tables should be generated from the data. For the Mud Dump site example, vertical erosion versus frequency-of-occurrence relationships were generated for each of the 100 simulations described above for each of the six depth/mound height configurations for both tropical and extratropical storms.

The frequency curves for each simulation are generated by (a) rank-ordering the computed erosion magnitudes, (b) generating a cumulative distribution function (cdf, $P(x)$ versus magnitude), and (c) interpolating an erosion magnitude for an n -year event from the cdf for a probability of occurrence $P(x)$ of the form resulting in an erosion versus frequency curve for each simulation.

Tropical storms. In the analysis of the 100 frequency relationships, an average vertical erosion magnitude is computed relative to each return period. From the EST simulations of tropical storms, an example plot of the 100 recurrence relationships and mean value (indicated by O) for the 8-ft mound located at an 83-ft depth is shown in Figure G7. Note that the spread of data points about the mean demonstrates a reasonable degree of variability, as would be expected of a stochastic process.

Finally, the standard deviation of the 100 events relative to the mean is computed as a measure of variability. Output for design purposes contains only the mean frequency-of-occurrence relationship with a +/- one standard deviation band. An example of this output is shown in Figure G8 for the 8-ft mound at the 83-ft depth shown in Figure G7. Table G8 summarizes the frequency-of-occurrence of vertical erosion from tropical storms for all six mound configurations in the form of a mean value and +/- standard deviation error that can be added to or subtracted from the mean value.

Extratropical storms. A set of analyses identical to those made for tropical storms should be made for the extratropical storms. From the Mud Dump site analysis, an example plot of the 100 recurrence relationships and mean value (indicated by O) for the 8-ft mound located at an 83-ft depth is shown in Figure G9. As for the tropical storms, the spread of data points about the mean demonstrates a reasonable degree of variability, as would be expected of any stochastic process. An example of the mean frequency-of-occurrence relationship with a +/- one standard deviation band is shown in Figure G10 for the 8-ft

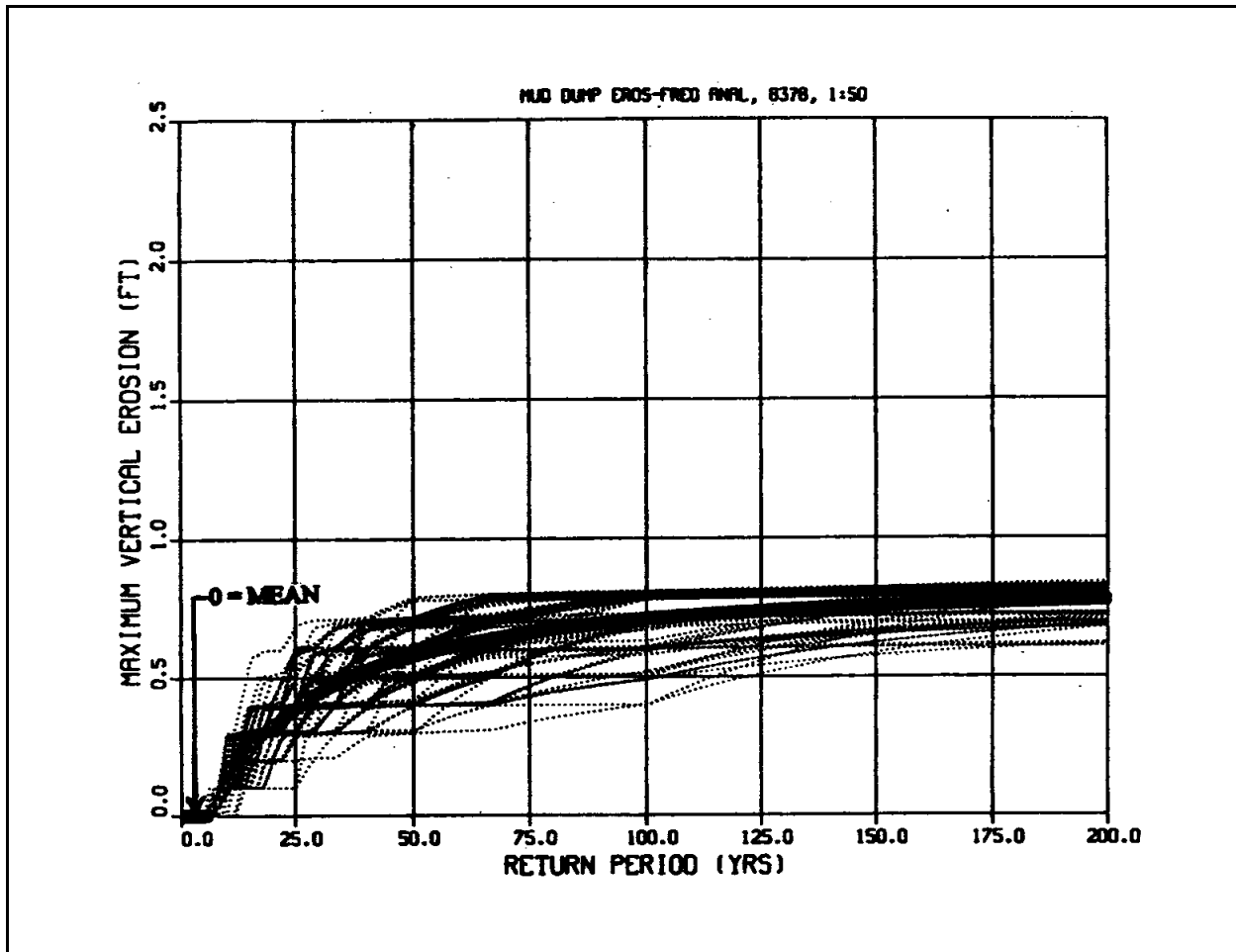

Figure G7. Simulated tropical storm-induced vertical erosion frequency curves for an 8-ft mound located at 83-ft depth, crest depth of 75 ft

Table G8 Mean Value of Vertical Erosion/Frequency-of-Occurrence for Tropical Storms at Mud Dump Site			
Test Number/ Ambient Depth - Mound Height/ Crest Depth, ft	25-year mean (± sd), ft	50-year mean (± sd), ft	100-year mean (± sd), ft
1 / (63-13) / 50	1.2 (0.23)	1.6 (0.23)	1.9 (0.26)
2 / (63-8) / 55	0.9 (0.19)	1.3 (0.23)	1.5 (0.19)
3 / (73-13) / 60	0.8 (0.18)	1.2 (0.22)	1.4 (0.20)
4 / (73-8) / 65	0.6 (0.13)	0.8 (0.17)	1.0 (0.16)
5 / (83-13) / 70	0.5 (0.12)	0.8 (0.14)	0.9 (0.15)
6 / (83-8) / 75	0.4 (0.10)	0.6 (0.12)	0.7 (0.10)

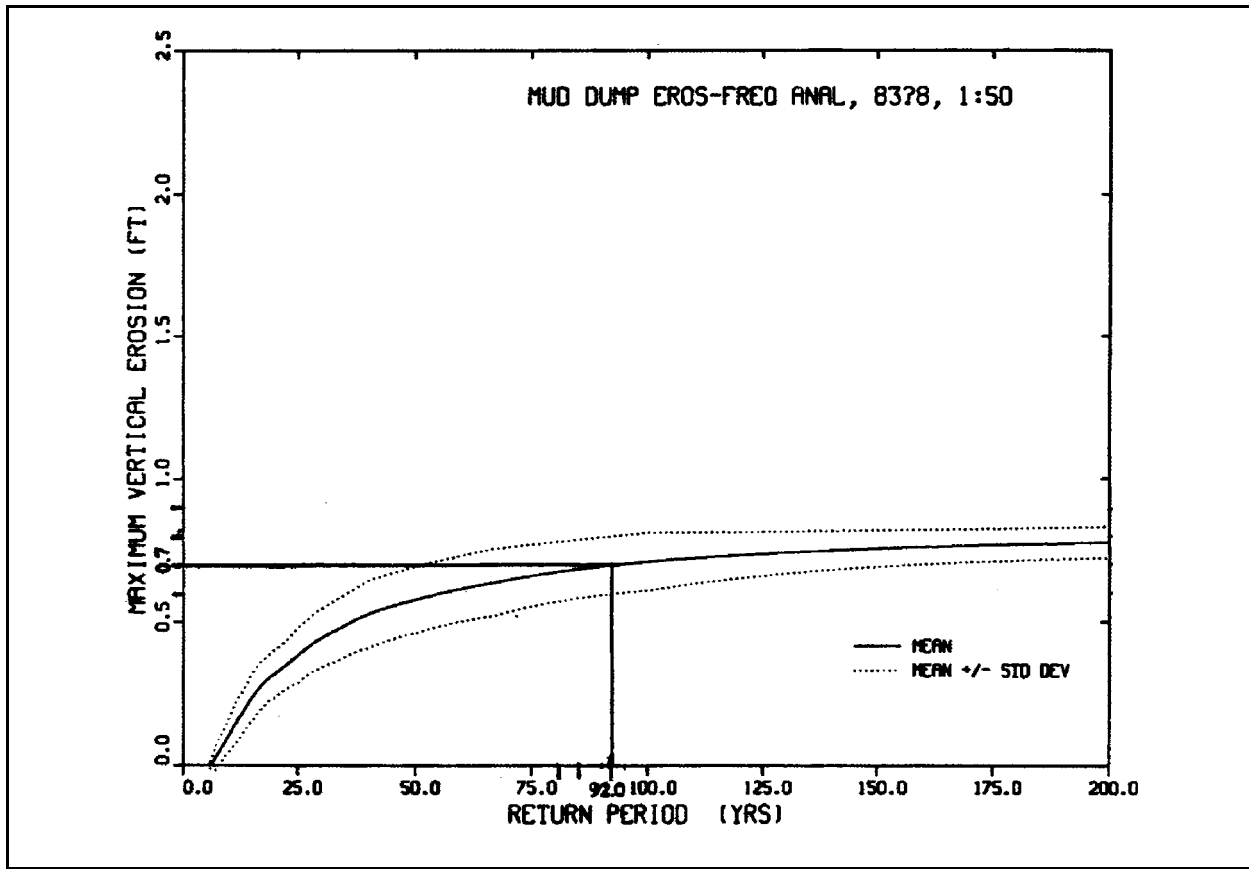

Figure G8. Mean value with error limits for frequency of vertical erosion from tropical storms for 8-ft mound located at 83-ft depth, crest depth of 75 ft

mound at the 83-ft depth. Table G9 summarizes the frequency-of-occurrence of vertical erosion from extratropical storms for all six mound configurations in the form of a mean value and +/- standard deviation error that can be added to or subtracted from the mean value.

Frequency of erosion for the combined impacts of tropical and extratropical storms

For most sites it is probably only practical (and cost effective) to replace any lost cap material due to erosion on a yearly basis. Therefore, for sites that experience both tropical and extratropical storms, the potential for vertical erosion from the combined impacts of both types of storms over a year's time must be considered. Proper design of a cap should consider both the episodic erosion from the less frequently occurring severe storms and the cumulative erosion from normal storm activity (average intensity storms experienced every year) experienced over a period of years. If this is not done, then after say 5 to 20 years of annual erosion, the remaining erosion thickness could fall below the design level (say a 100-year return frequency erosion event).

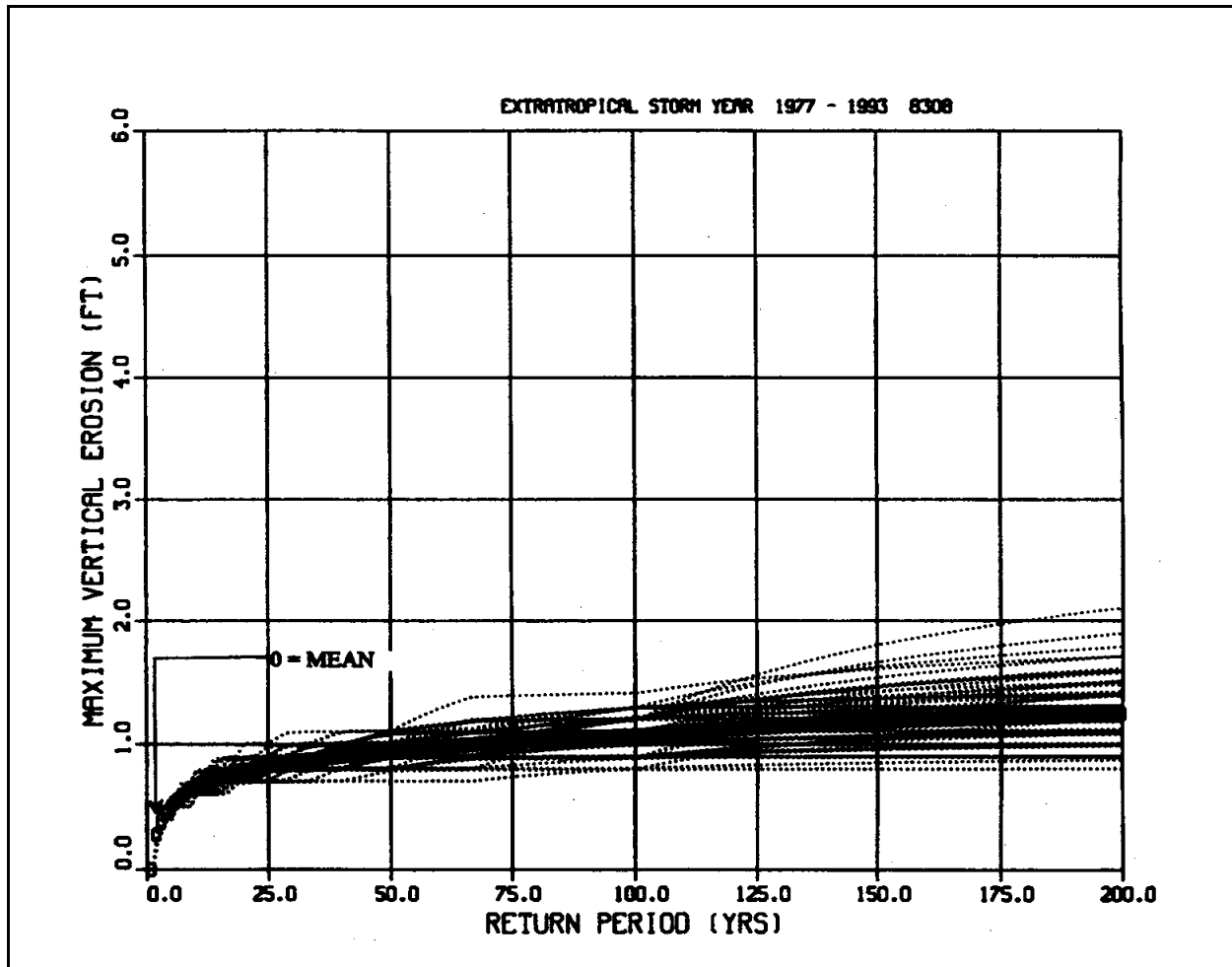

Figure G9. Simulated extratropical storm-induced vertical erosion frequency curves for an 8-ft mound located at 83-ft depth, crest depth of 75 ft

Table G9			
Mean Value Erosion/Frequency-of-Occurrence for Extratropical Storms at the Mud Dump Site			
Test Number/ Ambient Depth - Mound Height/ Crest Depth, ft	25-year mean (± sd), ft	50-year mean (± sd), ft	100-year mean (± sd), ft
1 / (63-13) / 50	3.0 (0.22)	3.4 (0.30)	3.9 (0.42)
2 / (63-8) / 55	2.1 (0.15)	2.3 (0.2)	2.6 (0.29)
3 / (73-13) / 60	1.8 (0.13)	2.0 (0.17)	2.3 (0.26)
4 / (73-8) / 65	1.3 (0.10)	1.4 (0.13)	1.6 (0.18)
5 / (83-13) / 70	1.1 (0.09)	1.3 (0.12)	1.5 (0.16)
6 / (83-8) / 75	0.8 (0.07)	0.9 (0.09)	1.1 (0.13)

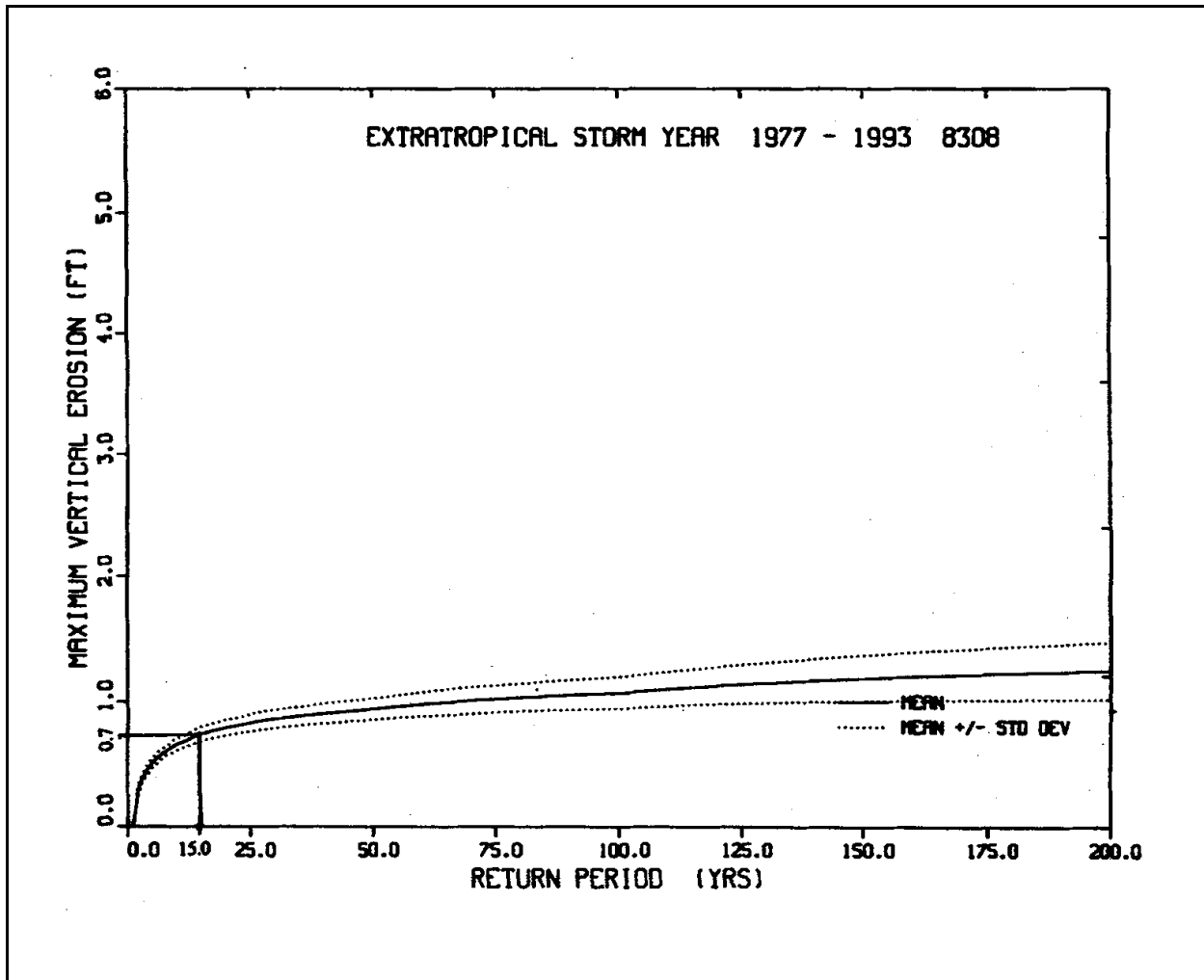

Figure G10. Mean value with error limits for frequency of vertical erosion from extratropical storms for 8-ft mound located at 83-ft depth, crest depth of 75 ft

Therefore, estimates of potential erosion of a disposal mound in the New York Bight require an analysis of both (a) episodic event erosion resulting from tropical and extratropical storms and (b) cumulative erosion. For the Mud Dump site, cumulative erosion would be considered to be due only to average intensity extratropical events. Tropical events are not considered in the average yearly erosion rate because tropical events impact the Bight at a return period of approximately 6.5 years. At more southerly east coast sites and Gulf coast sites, tropical storms may need to be considered for the yearly average erosion computations.

Cumulative erosion. As noted above, cumulative erosion is the vertical erosion expected to occur over intervals of 5 to 20 years due to a normal storm activity, i.e., moderate storms that occur regularly. Because cumulative erosion over periods of 5 to 20 years may consist of a fairly large number of storms, it is

important that erosion per storm and the cumulative effects be computed as realistically as practical.

A simple method to compute cumulative erosion is to compute an annual average erosion then multiply that value by the number of years of interest. This can be done by examining the full set of training storms modeled in the erosion frequency analysis, then summing the maximum erosion from each storm and dividing by the number of storms to compute the average maximum erosion per storm. The average annual erosion could then be computed as the average maximum erosion per storm times the average number of storms per year (e.g., 2.375 for the Mud Dump site). This method would likely produce extremely conservative estimates of annual erosion because successive storms would not necessarily produce erosion in the same location. Also as the mound erodes, the elevation decreases, which decreases the erosion rate during future storms. This method also includes the erosion from severe, infrequent storms which would perhaps cause some significant cap erosion such that the cap would have to be repaired.

A correction for the gross annual erosion estimates computed by the above method could be calculated by computing the total mound erosion resulting from a series of low to moderate intensity storms (those with erosion frequencies of less than 5-10 years) applied consecutively (using LTFATE) to a specific mound configuration. The mound geometry from the first storm would be the initial geometry for the second storm and so on. The maximum total erosion at any location on the mound after a series of storms that could normally be experienced in a year (say two to four for the Mud Dump) applied consecutively could then be compared with the maximum total cap erosion of each storm summed individually. The correction factor would then be the ratio of the consecutive total maximum erosion divided by the individual total maximum erosion. Average annual erosion would then be the number of storms per year times the maximum average erosion per storm times the correction factor. Cumulative erosion would then be the corrected average annual erosion times the number of years of interest.

A more sophisticated estimate of cumulative annual erosion values would be to use LTFATE to model erosion for a particular capped mound configuration for a period of 10 to 20 years from which the training storms were selected. The storm-induced capped mound geometry from the initial storm would be, as above, the input geometry for the following storm, with the resulting capped mound geometry from each preceding storm becoming the input geometry for the subsequent storm.

At the end of each year, the maximum erosion, average erosion thickness, and area of erosion (as defined in Figure G11) would be computed. Because of the multiple years of data, running averages of each of the quantities could be computed along with basic statistics such as the average, maximum, and standard deviation. With these values a considerably more realistic estimate of annual and cumulative annual erosion is more likely. Additional research on the application of this suggested approach to actual projects is planned to determine

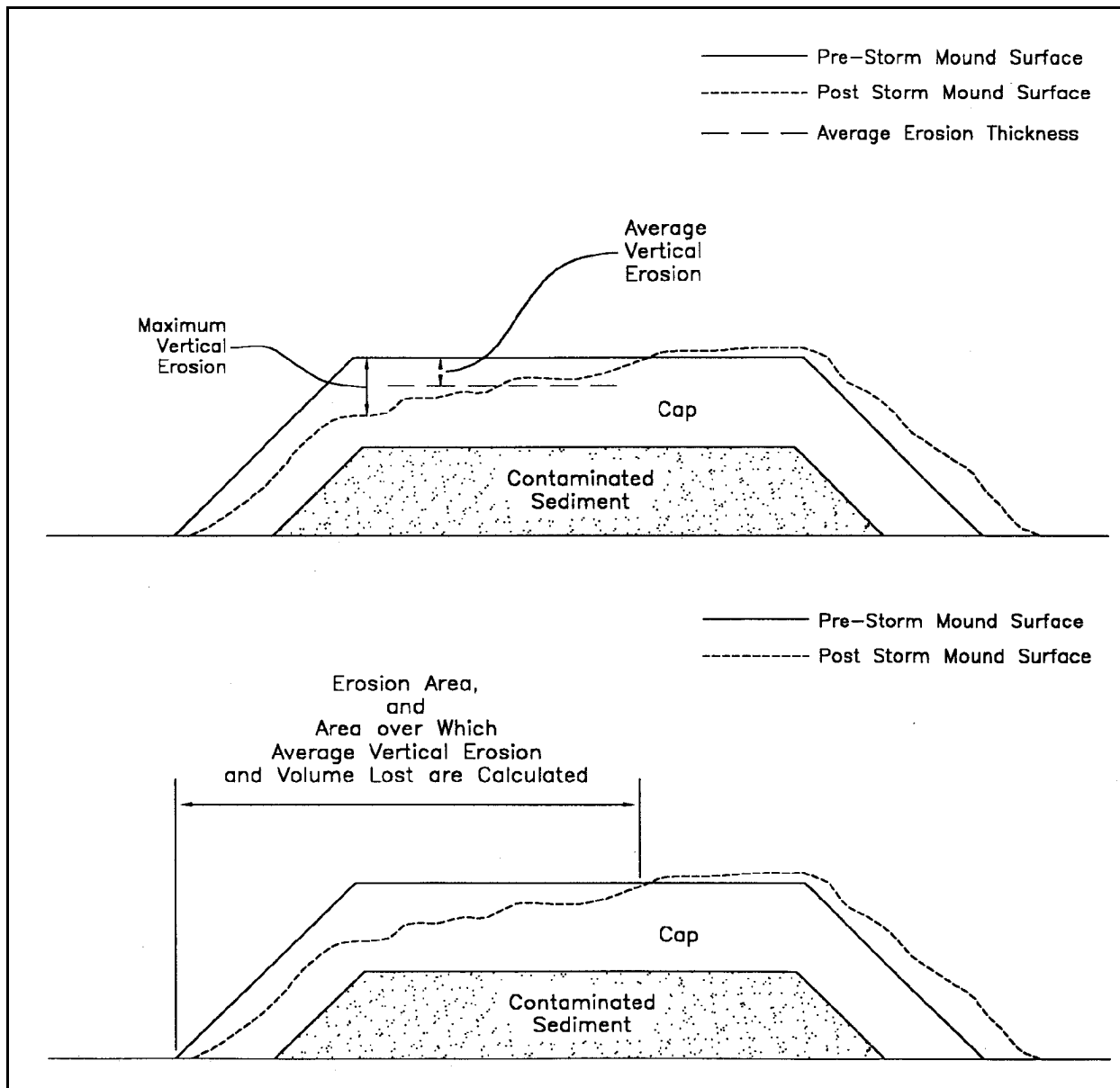

Figure G11. Idealized mound cross sections showing maximum and average vertical erosion and areas over which erosion volume is computed

if in fact, this more complicated method of computing annual and cumulative erosion estimates provides significantly different answers than the simpler methods.

Episodic erosion. Episodic event erosion was individually described for tropical and extratropical events in the prior sections. For tropical events, the curves and tables represent the vertical erosion associated with individual hurricanes. For example, a 100-year erosion value is the erosion associated with a single severe event with a return period of 100 years. However, the curves and tables presented for the extratropical events represent erosion due to multiple

events occurring during a single storm season. For example, although an average of only 2.4 events occur per year at the Mud Dump site, results from the program EST generates a simulated 200-year sequence of extratropical storm activity during which it is possible to have eight or nine events in a single season. If eight or nine severe events were to occur during a single winter season, the summation of maximum erosion magnitudes for each event may be large enough for that season to be ranked as a 100-year season.

The erosion versus frequency-of-occurrence relationships for tropical and extratropical events were combined to generate a single curve and table of frequencies for each of the design configurations. The combined frequency-of-occurrence is computed by adding the frequencies associated with tropical and extratropical events for a given magnitude of erosion. For example, consider the 8-ft mound located in 83 ft of water. An erosion of 1.0 ft corresponds to a return period of 83 years for hurricanes but only 10 years for extratropical events. The combined frequency is equal to $1/83 + 1/10$ or 0.11, corresponding to a return period of just 9 years. A comparison of the combined event, Table G10, shown below, and Tables G8 and G9, shows that extratropical events are the dominant storm type in the New York Bight. This dominance is evidenced by the fact that the combined event frequency relationships are very similar to the extratropical relationships. This is not surprising considering that on the average, 15 extratropical storms occur for every hurricane. Also, vertical erosion due to extratropical events is generally more severe than for tropical events due to the longer duration of extratropical storms.

Table G10				
Mean Maximum Vertical Erosion Frequency due to Tropical and Extratropical Storms Impacting 0.4-mm Sand-Capped Mounds				
Mound Configuration Base Depth/Mound Height/Crest Depth, ft	Combined Hurricane/Northeaster Single-Year Erosion Frequency, ft			
	10 year	25 year	50 year	100 year
63/10/50	2.4	3.0	3.4	3.9
63/08/55	1.6	2.0	2.3	2.6
73/13/60	1.5	1.8	2.0	2.3
73/08/65	1.0	1.3	1.5	1.7
83/13/70	0.9	1.2	1.3	1.6
83/08/75	0.7	0.8	0.9	1.1

A summary of results for the Mud Dump site, shown in Table G10, was prepared to provide both episodic and cumulative erosion estimates for each design option. The episodic values are provided at return periods of 10, 25, 50, and 100 years.

For example, the 100-year mean maximum erosion thickness for combined storms for a mound in 73 ft of water that is 8 ft tall with a crest elevation of 65 ft is 1.7 ft.

Use of Table G10 for evaluating disposal site design parameters such as cap thickness or site depth should consider both episodic event erosion and net cumulative erosion. Yearly monitoring of the disposal site should be conducted to ensure that the cap has maintained its integrity, i.e., cap thickness has not been reduced by erosion below the minimum safe level. Even with annual monitoring, the cap should be designed to withstand multiyear erosional events. Therefore, the disposal site should be designed such that the cap will not be compromised by either (a) episodic event (tropical) or episodic season (extra-tropical) erosion of some defined level of intensity such as the 100-year occurrence or (b) several years, 5 for example, of normal storm activity.

Summary

In conclusion, vertical erosion frequency and annual cumulative erosion estimates generated through the techniques described in this appendix can be used as a basis for designing a capped disposal mound. However, it should be emphasized that the erosion magnitudes reported can be considered somewhat conservative for the following reason:

Single event erosion is calculated as the maximum erosion computed at any location on the cap as a result of the single event. In most cases, this erosion is limited to the edge of a cap at the intersection of the side slope and the crest. If localized erosion of the cap were indicated by annual surveys, maintenance or remedial disposal could easily restore the cap to its design thickness at the appropriate location. The amount of cap material that would be required to restore the cap to its original thickness is roughly estimated at 10 to 25 percent of the original cap volume. Computations of average mound erosion thickness and the area of mound experiencing erosion are recommended to provide additional insight on the potential for cap failure.

The storm-surge frequency analyses described in this study make extensive use of the EST. The approach requires the generation of a database of storm responses that, for this analysis, were selected to be vertical erosion. Because the procedure is a statistical one based on a training set of single-event erosion magnitudes, the above assumptions leading to conservatism cannot be eliminated from the analysis. Therefore, the fact that the estimates are conservative must be considered in the final design.

For specific cap design projects, a comprehensive and rigorous analysis of the cumulative erosion due to the occurrence of multiple events per year is recommended. This could include either computing a gross erosion reduction factor or an LTFATE simulation of multiple years of normal storm activity.

Finally, the procedures recommended in this appendix to generate vertical erosion versus frequency of occurrence utilizes a newly generated database of tropical and extratropical storm surge elevation and current hydrographs. No similar database has ever been available for use in an analysis similar to this. Because the present analysis uses this database in conjunction with thoroughly tested and documented hydrodynamic, sediment transport, and bathymetry change modeling concepts, the approach can be considered to be comprehensive, reasonably accurate, and appropriate for the purpose of developing disposal site design criteria. Future improvements in the algorithms used to compute sediment transport, better values for storm induced processes, and more high quality data on storm-induced erosion of dredged material mounds will provide higher levels of accuracy in the computations and greater confidence in cap design.

Appendix H

Calculation of Required Cap Volumes for Level-Bottom Capping Projects

The primary focus of this appendix is the calculation of the volume of capping material required for level-bottom capping projects, including the influence of various operational considerations on required volumes. The information in this appendix assumes a specific capping project has been identified, a disposal site is available, the contaminated mound geometry (footprint, side-slopes, and elevation) has been estimated, and the cap has been designed with respect to the thickness of capping material required.

Capping Volumes for Circular and Elliptical Mounds

From a plan view, capped mounds typically take either a circular or elliptical/oval shape (Chapter 10, main text), so required cap volume calculations depend on this shape. For a uniform cap thickness over the entire contaminated mound surface (Figure H1), design must allow for inclusion of the cap volumes of the inner flank, outer flank, and apron in the overall mound cap volume calculation. This will be demonstrated in a generic example. If the cap thickness will be less over the apron (Figure H2), then the cap volume calculation requires isolating different sections of the cap for ease in calculation. For both cases, the volume of cap material included in the apron must also be calculated as constructed projects have shown this volume can be significant. Note that the following relationships are unit independent (i.e., either English or SI may be used as long as consistency is maintained).

For a uniformly thick cap on a circular mound (Figure H1), the following methodology is given to calculate cap volume:

$$\begin{aligned}
 V_M &= t_c \pi r_M^2 \\
 V_{CA} &= \pi (r_{TC}^2 - r_M^2) \frac{1}{2} t_{ta}
 \end{aligned}
 \tag{H1}$$

where

V_M = volume of cap material over dredged material mound

V_{CA} = volume of material in cap apron

t_c = thickness of cap

t_{ta} = thickness of cap at toe of mound apron

r_M = radius of overall dredged material mound

r_{TC} = radius of total capped surface

For a uniformly thick cap on an elliptical mound, the following methodology is given to calculate cap volume:

$$\begin{aligned}
 V_M &= t_c (\pi r_1 r_2) \\
 V_{CA} &= \pi [(r_1 r_2)_{TC} - (r_1 r_2)_M] \frac{1}{2} t_{ta}
 \end{aligned}
 \tag{H2}$$

where

V_M = volume of cap material over dredged material mound

V_{CA} = volume of material in cap apron

t_c = thickness of cap

t_{ta} = thickness of cap at toe of mound apron

r_1, r_2 = long, short radius of ellipse

M = subscript for dredged material mound

TC = subscript for total capped surface

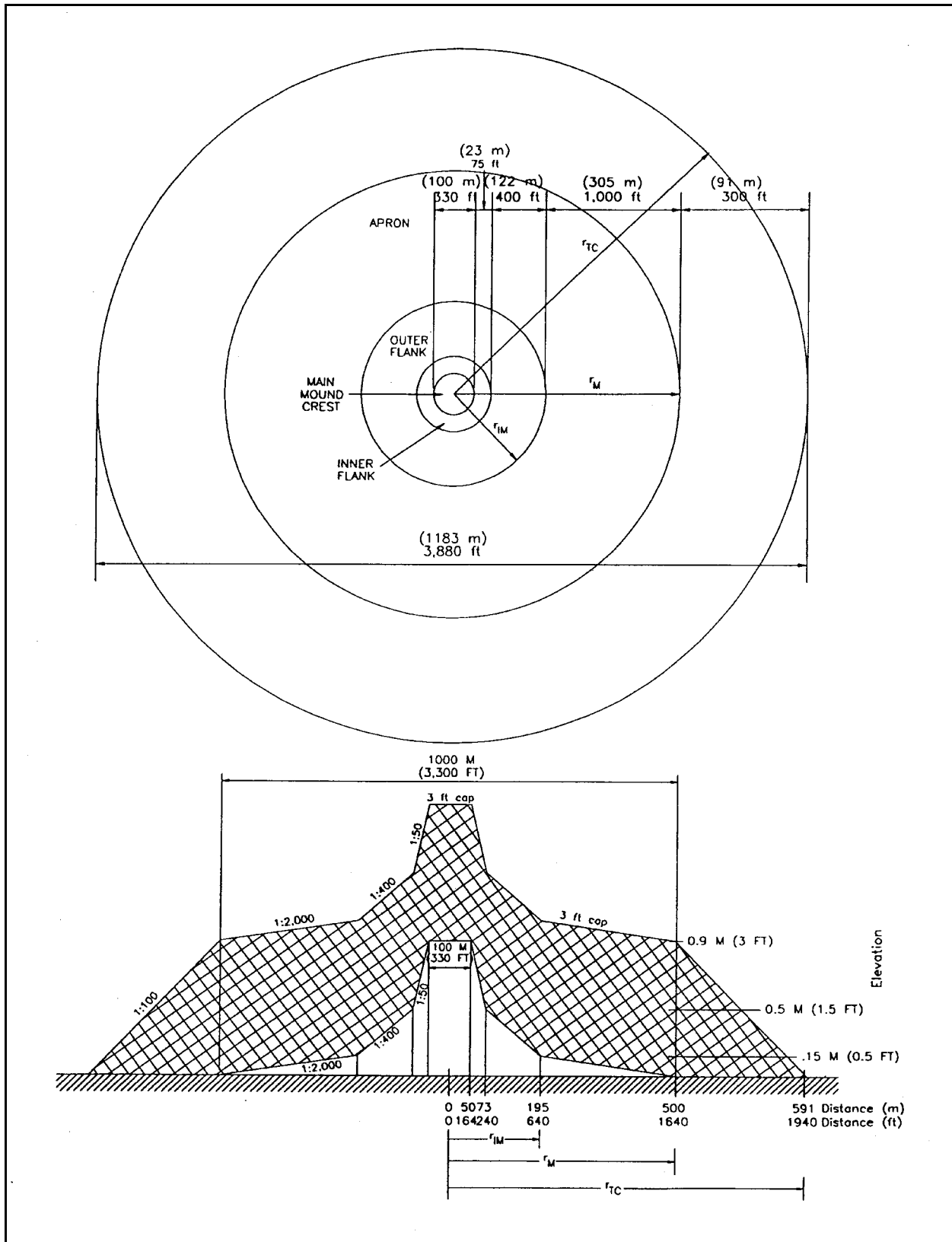

Figure H1. Geometry for a uniform cap thickness over a mound

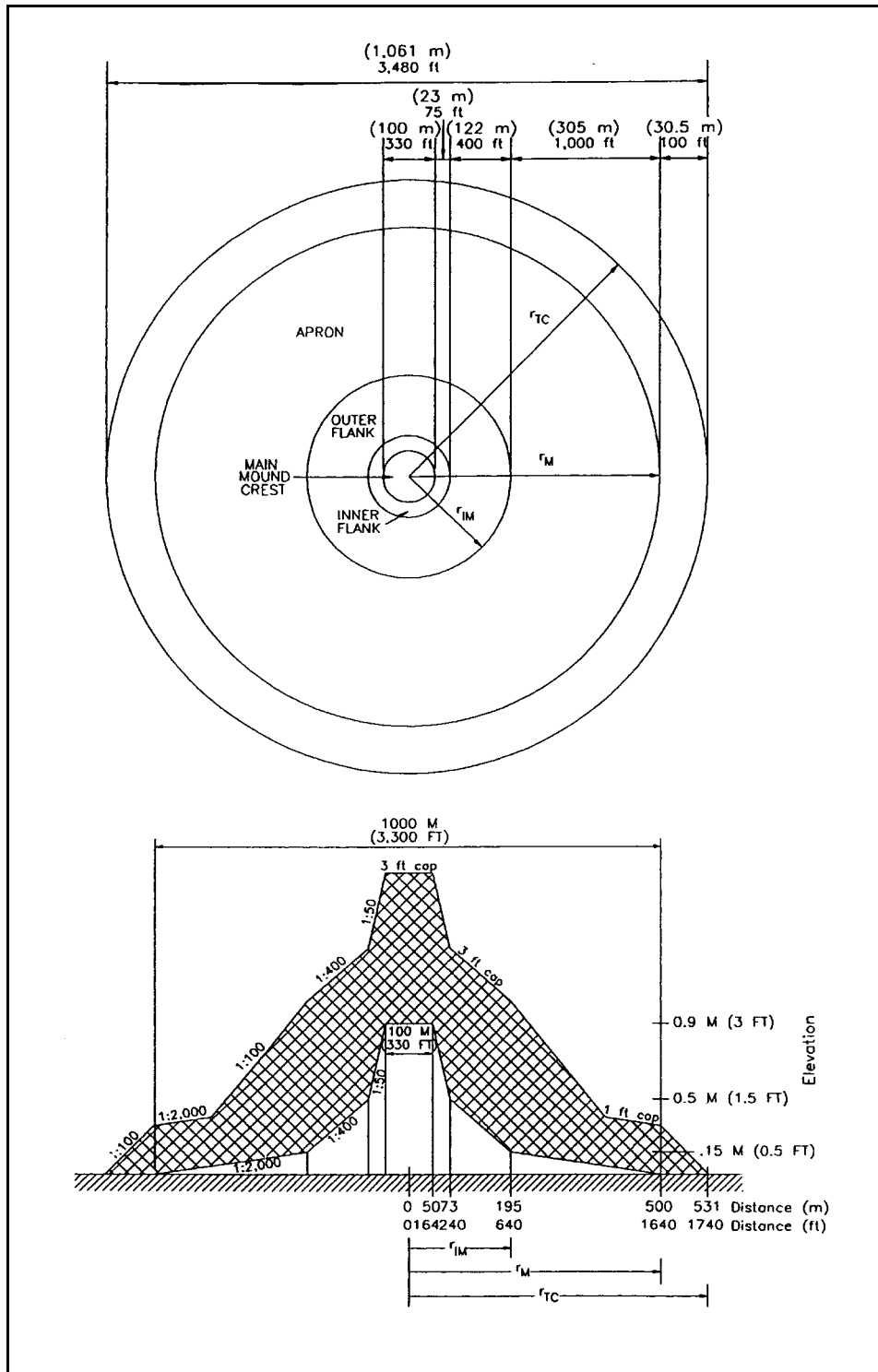

Figure H2. Geometry for a uniform cap with lesser thickness over apron

For a circular mound where the cap thickness is decreased over the apron (Figure H2, the following methodology is given to calculate cap volume:

$$V_M = t_{pc} \pi r_{IM}^2 + 0/00 \Delta t_c \pi \left[\left(r_{IM} + \Delta \frac{t_c}{m} \right)^2 - r_{IM}^2 \right] + \pi t_{ta} (r_M^2 - r_{IM}^2) \quad (H3)$$

$$V_T = V_M + V_{CA}$$

where

V_M = volume of cap material over dredged material mound

V_{CA} = volume of material in cap apron

V_T = total volume of cap material

t_{pc} = thickness of primary cap

t_{ta} = thickness of cap at toe of mound apron

t_c = change in cap thickness over apron ($t_{pc} - t_{ta}$)

r_M = radius of overall dredged material mound

r_{IM} = radius of inner dredged material mound (crest, inner flank and outer flank)

r_{TC} = radius of total capped surface

m = slope of change in cap thickness (i.e., 1:100!m=0.01)

$$V_M = t_{pc} \pi r_1 r_2 + 0/00 \Delta t_c \pi \left[\left(r_{1IM} + \frac{\Delta t_c}{m} \right) \left(r_{2IM} + \frac{\Delta t_c}{m} \right) - (r_1 r_2)_{IM} \right] + \pi t_{ta} [(r_1 r_2)_M - (r_1 r_2)_{IM}] \quad (H4)$$

For an elliptic mound where the cap thickness is decreased over the apron, the following methodology is given to calculate cap volume:

$$V_T = V_M + V_{CA}$$

$$V_{CA} = \pi [(r_1 r_2)_{TC} - (r_1 r_2)_M] \frac{1}{2} t_{ta} \quad (H5)$$

where

V_M = volume of cap material over dredged material mound

V_{CA} = volume of material in cap apron

V_T = total volume of cap material

t_{pc} = thickness of primary cap

t_{ta} = thickness of cap at toe of mound apron

t_c = change in cap thickness over apron ($t_{pc} - t_{ta}$)

r_1, r_2 = long, short radius of ellipse

M = subscript for dredged material mound

M = subscript for inner dredged material mound (crest, inner flank and outer flank)

TC = subscript for total capped surface

m = slope of change in cap thickness (i.e., 1:100!m=0.01)

The volume of cap material overlying the inner and outer flanks may be calculated as part of the overall dredged material mound cap volume calculations. When there is no change in cap thickness over the mound apron as in Figure H1, the cap volume over the mound apron may also be included in the overall dredged material mound cap volume calculations. To demonstrate, assume a generic circular mound having a relief of 2.1 m (7 ft) with cap 0.9 m (3 ft) thick is created (Figure H3). Approximate average inner flank, outer flank, and apron slopes are 1:50, 1:400, and 1:2000, respectively. Table H1 shows that for this example, the horizontal length and slope length are nearly equal, so use of the horizontal length in cap volume calculation is justified. For steeper slopes and/or higher mound relief, this assumption should be verified.

Table H1 Lengths Associated with Generic-Capped Mound in Figure H3						
	Vertical Length		Horizontal Length		Slope Length	
	m	ft	m	ft	m	ft
A - B Inner Flank	0.9	3	46	150	46.009	150.03
B - C Inner Flank	0.9	3	366	1,200	366.0011	1,200.00375
C - D Apron	0.3	1	610	2,000	610.000074	2,000.00025

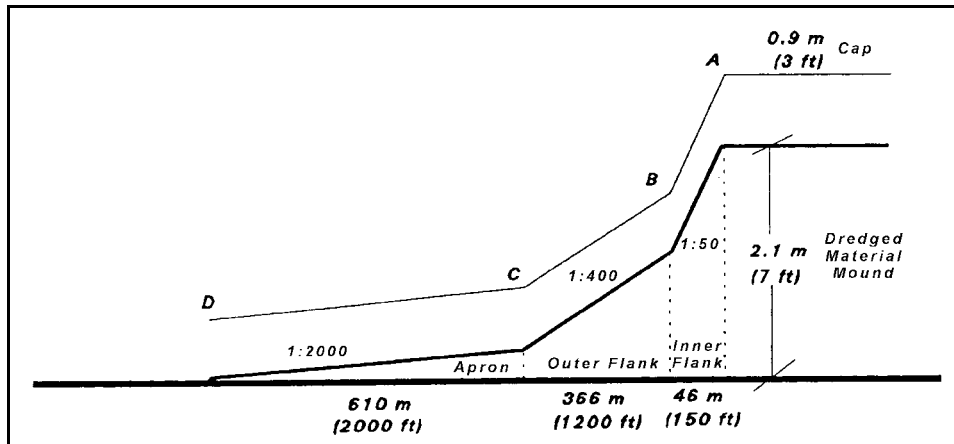

Figure H3. Cap slope length calculation

Effect of Placement Operation on Required Cap Volume

A number of operational factors should be considered in computing required cap volume. These factors include the “full” cap thickness versus “average” cap thickness, the required cap thickness over the apron, and how far beyond the contaminated boundary the cap should be placed. The following paragraphs discuss each of these factors in turn. In general, cap volume to contaminated sediment volume ratios of 1:2 to 1:5 have been used for capping projects. While the following paragraphs describe how to compute specific cap volume requirement, some generalizations can be made. Higher cap to contaminated material ratios will be found for projects that use thin mounds, those consisting of maintenance material that is fine grained with low shear strength, where barges placing contaminated material will not be required to stop, and sites with deeper water. Also, for smaller volume contaminated sediment projects, the apron will tend to occupy an increasingly large percentage of the total area, greatly increasing required cap volume to contaminated sediment volume ratio (particularly if the full cap thickness is required over the entire apron). Lower cap to contaminated sediment volumes can be expected for thicker mounds, those consisting of material with high shear strength, mounds placed in shallow water, where barges come to a complete halt or are moving at low speeds (less than 1/2 to 1 knot).

Achieving full cap thickness over the entire contaminated mound footprint is nearly impossible to accomplish without placing a considerable amount of additional material over that required for a level cap. This is because underwater placement is difficult to precisely control. Depending on the method of cap placement, the cap surface will have greater or lesser amounts of surface relief. For caps that are “sprinkled,” this degree of surface relief will probably be less for sprinkled caps than for bottom-dumped caps.

One issue that must be resolved for cap design is whether or not the entire cap area requires the “full cap thickness.” While a cap with a constant thickness

is assumed for calculations, in reality, the cap thickness is a distribution, with an average value and the actual cap depth in specific cells (say 50 by 50 m) probably following a Gaussian distribution. For example, if a 1-m-thick cap is specified and the standard deviation of cap thickness is 15 cm (6 in.), after 100 percent of the level cap volume has been placed, 99 percent of the contaminated footprint would have 0.55 m of cap, 95 percent would have 0.70 m of cap, 67 percent would have 0.85 m of cap, 50 percent would have 1.0 m of cap, 33 percent would have 1.15 m of cap, 5 percent would have 1.3 m of cap, and 1 percent would have 1.45 m of cap. Should more cap material be placed?

It is recommended that the cap be considered complete if all the contaminated sediment has a minimum thickness equal to thickness required for chemical isolation and bioturbation plus some agreed on thickness, say 5 to 10 cm, to account for elevation variation within a given cell. The reason this procedure is acceptable is that during storms, it is extremely likely that the high spots on the cap will erode first and fill in the low areas. Thus, the requirement to place material in excess of the “level surface cap volume” should be unnecessary.

In addition to the large amount of additional material placed to meet the requirement to achieve 100-percent thickness everywhere over a cap, this requirement will also dictate repeated monitoring, which is also expensive. Finally, the actual placement process becomes less efficient as the vessel placing the cap material attempts to cover a smaller and smaller area. Statistics from the capping effort at the Port Newark/Elizabeth project (Table H2), where the goal was to place 1-m-thick cap over the entire contaminated mound, indicated that an additional 25 percent over the level cap volume was required to achieve full cap thickness coverage at over 90+ percent of the area, resulting in cap thicknesses of over 1.25 m over almost 40 percent of the area.

Table H2 Final Statistics of Cap Thickness from Port Newark/Elizabeth Project (March 1994)		
Cap Thickness, m	Percent of Area Covered	Cumulative Coverage, Percent
0.00 - 0.25	0.0	0.0
0.25 - 0.50	0.2	0.2
0.50 - 0.75	2.9	3.1
0.75 - 1.00	16.4	19.5
1.00 - 1.25	42.2	61.7
1.25 - 1.50	30.4	92.1
1.50 - 1.75	6.5	98.6
1.75 - 2.00	1.1	99.7
2.00 - 2.25	0.1	99.8

To calculate required cap volume, it is recommended that the “full cap thickness” volume (i.e., a level cap at full thickness) be computed over the main mound and inner flanks. Up to an additional 10-20 percent of cap material should be identified as possibly being required and should be available.

The required cap thickness over a few centimeters-thick mound apron can become an important issue when one considers the volume (and cost) of cap material required to cover mound aprons. Table H3 compares volumes and dimensions from the Port Elizabeth/Newark project (which required a 1-m cap over the entire contaminated mound) and two generic cap projects based on the mounds shown in Figures H1 (0.9-m cap over the entire mound) and H2 (0.9-m cap over the main mound and a 0.3-m cap over the apron). Volume calculations show that over half (55.6 percent) of the 1,870,000 m³ (2,446,000 yd³) of material placed at the Port Elizabeth/Newark mound covered the contaminated mound apron, which contained about 12 percent of the contaminated material volume. Table H3 also shows that in the generic mounds shown in Figures H1 and H2 (identical contaminated mound shapes), the total volume of cap material required is reduced by nearly 60 percent, from 847,200 m³ (1,108,100 yd³) to 347,800 m³ (454,900 yd³) when the required cap thickness over the apron is reduced from 1 to 0.3 m. The volume required to cover the contaminated apron reduces from 16.4 to 4.3 percent of total cap volume. The dredging and cap placement over the wide area covered by the apron will, for most projects, significantly increase the project costs. In rare instances where an abundance of cap material is being dredged as part of an authorized dredging project, the cap material can be considered “free.” However, the capping project must still cover the additional cost of precisely placing the cap.

For low levels of contaminants, bioturbation-induced mixing of the cap-contaminated material and native sediment may be sufficient to reduce the resulting level of contamination to an acceptable level. McFarland (in preparation)¹ describes procedures that can be used to determine the effects of reduced cap thicknesses over the apron based on bioaccumulation studies. For the sediments used on the Port Newark/Elizabeth 1993 project, McFarland (in preparation) found that a cap thickness to apron thickness ratio of 2:1 was sufficient to reduce bioaccumulation of the contaminant of concern (dioxin) to acceptable levels. The apron thickness for the Port Newark/Elizabeth mound ranged from 1 to 10 cm with a 5 cm average thickness. Thus using McFarland’s results, a cap thickness over the apron of 10 to 20 cm would have been sufficient. Most of the capped mounds created as part of the New England Division’s capping program have cap thicknesses over the apron of 20 to 50 cm.

Another issue impacting the amount of cap required is how far beyond the known contaminated mound boundary to place cap material. Because the edge of the cap will normally be located with a sediment profiling camera, the edge of the contaminated material will normally be defined to a precision of about 50 m. Therefore, it seems reasonable to place cap material such that the cap material

¹ References cited in this appendix are listed in the References at the end of the main text.

Table H3 Contaminated and Cap Material Volumes and Mound Dimensions					
Project	Tot Vol, m³ (yd³)	Apron Vol, M³ (yd³)	% Total	Footprint, m², (acres)	Max thick, m (ft)
Contaminated					
Port Elizabeth/ Newark	448,000 (586,000)	52,000 (68,000)	11.6	1,470,000 (363)	2.40 (8.0)
Generic No. 1 (Figure H1)	96,600 (126,300)	49,900 (65,300)	51.7	785,400 (194)	0.9 (3.0)
Generic No. 2 (Figure H2)	96,600 (126,300)	49,900 (65,300)	51.7	785,400 (194)	0.9 (3.0)
Cap					
Port Elizabeth/ Newark (1 m cap over entire project)	1,870,000 (2,445,900)	1,040,000 (1,360,300)	55.6	1,470,000 (363)	1.8 (5.91)
Generic No. 1 (Figure H1) (0.9 m cap over entire project)	847,200 (1,108,100)	140,400 (183,600)	16.6	1,097,000 (271)	0.9 (2.95)
Generic No. 2 (Figure H2) (0.9 m cap over main mound, 0.3 m cap over apron)	347,800 (454,900)	15,100 (19,750)	4.3	885,800 (219)	0.9 (2.95)

extends a distance of 15 to 30 m beyond the expected edge of the contaminated material.

For sites with significant currents (say 30-50 cm/sec and greater) some loss of cap material will probably be experienced. The Seattle District has documented that for small sites (100 to 150 m overall dimensions) this “volume lost,” which is a actually cap material that is moved beyond the edge of the contaminated sediment, can be from 10 to 20 percent of the estimated volume required based on a flat cap over the contaminated sediment footprint (Parry 1994).

For a fine-grained cap, the volume lost to consolidation will have to be taken into account for the erosion layer. An estimate of the amount of consolidation over time will be required and the additional thickness added to account for potential erosion. Note that the reduced cap thickness from consolidation may not be a problem from a chemical isolation standpoint due to advection of contaminants. The reduced cap thickness from consolidation is somewhat compensated for by the reduced void ratio and permeability, creating more tortuous paths for the contaminants to diffuse through.

However, the reduction in cap thickness due to consolidation should be considered from the standpoint of advection of pore water. Consolidation will reduce the void ratio and thus will force pore water further out into the cap.

Effect on Volume Due to Change in Void Ratio

The volume of material to be dredged for the cap must be calculated to determine if potential sources of capping material, say from an available maintenance dredging project, will be adequate. The potential changes in volume due to dredging and placement must be considered. The required volume of capping material (in situ in the channel) can be calculated as follows:

$$V_{ci} = V_c \left(\left[\frac{(e_o - e_i)}{(1 - e_i)} \right] + 1 \right) \quad (\text{H6})$$

where

V_{ci} = volume of cap material in situ in channel

V_c = volume of cap material initially placed

e_o = average void ratio of cap material initially placed

e_i = average void ratio of cap material in situ in channel

For projects in which the capping material is hydraulically placed, the value of e_o can be determined in the same way as that used in design of confined disposal facilities (USACE 1987, EM 1110-2-5027). For mechanically dredged sediments, an approach to determine the minimum cap volume required is to assume no difference in e_o and e_i (i.e., $V_{ci} = V_c$). It is recommended that those with experience dredging a particular project (USACE District Operations Division staff, dredging contractors, etc.) be contacted for suggestions on bulk-ing factors. SAIC (1995) reports that the assumption of no difference in e_o and e_i is reasonable.

Options if Required Volume is Too Large

The information from the prior section along with the information in Chapter 6 (main text) on expected contaminated mound footprint should be used to compute required cap volume. If the estimated cap volume is too large, either because insufficient cap material is available or the cost is too high, the following options are available. As noted earlier, the most obvious is to reduce the volume of contaminated material. A second option may be to delay dredging until additional cap material becomes available, perhaps combining several small

projects that collectively can afford the cap required. Other options involve creating a contained aquatic disposal (CAD) site, either by creating berms from clean material (perhaps dredged from the disposal site creating additional capacity) or potentially using geotextile fabric containers. Use of geosynthetic fabric containers (GFCs) to contain the contaminated sediments is also an option to reduce the amount of cap required. However, this is a fairly recent development, and specific guidelines for this application are not yet available. Clausner et al. (1996) summarize the present state of knowledge and critical issues for geotextile container use with contaminated dredged material.

Good advance planning can be used to create a “natural” CAD site. As described in Chapter 6, over a several-year time period, the New England Division created a series of capped mounds in a circle. The de facto CAD site in the center was then used for a rather large project. This technique greatly reduced the potential spread of the contaminants and allowed a low cap volume to contaminated sediment volume ratio. Fredette (1994) describes this project in detail.

Appendix I

Consolidation Testing

Consolidation Testing Procedures

Consolidation analysis of soft dredged material requires that laboratory compressibility data be obtained across the entire, wide range of void ratios that are commonly encountered in these soft materials as they consolidate. Void ratios in dredged materials can vary much more than those of normal soils. In typical (nonsediment) soils in the natural state, void ratios normally vary between 0.25 and 2.0, with some soft organic clays reaching 3.0. Recently deposited in situ sediments often have void ratios as high as 5 or 6, double or triple the values of most soils. When dredged by hopper or hydraulic dredges, the initial void ratios after disposal may reach as high as 10 to 12; in a few clayey sediments; the maximum values may reach even higher. Mechanical dredging does not dramatically alter the void ratio of the mass of dredged material; however, there will be clumps of material at about the in situ void ratio with much softer (slurry consistency) material between the clumps.

Laboratory consolidation testing of soft materials often requires use of at least two types of consolidation tests. Both a modified version of the standard oedometer consolidation test and a self-weight consolidation test must normally be conducted; these tests provide data for the low and high ends of the anticipated range of void ratios, respectively. However, on relatively firm dredged materials that are mechanically dredged, use of oedometer testing alone may suffice.

Several additional consolidation test devices and procedures have been developed and evaluated in recent years, but none are currently available or recommended for routine dredged material testing. Some of these devices were intended to supplement the self-weight and oedometer test by providing more continuous void ratio-effective stress ($e-\sigma$) and void ratio-permeability ($e-k$) throughout the middle ranges of interest, while some devices were intended to provide all of the necessary data, thus eliminating the need for any other tests (e.g., Poindexter 1988). Because of continued widespread interest in slurry consolidation in the dredging, mining, and phosphate industries, it is anticipated that the American Society for Testing and Materials (ASTM) will develop a

standard (or standards) for consolidation testing of very soft materials in the near future.

The modified oedometer test procedure is outlined in Appendix D of EM 1110-2-5027 (U.S. Army Corps of Engineers (USACE) 1987). The self-weight consolidation test and its interpretation and use have been described by Poindexter (1988) and Poindexter-Rollings (1990). Both of these consolidation tests will be briefly discussed below. For additional information and exact testing procedures, the reader is referred to the following documents: ASTM D 2435, USACE (1986), USACE (1987), Cargill (1986).

Standard Oedometer Test

The standard oedometer (consolidometer) test can be used to conduct consolidation tests on dredged materials and foundation soils, as shown in Figure I1 (USACE 1986). Due to the soft, often fluidlike consistency of the sediment samples normally tested, the fixed ring consolidometer should be used, instead of the floating ring device, since extrusion of the sample from the device will be less likely in the fixed ring consolidometer. Sample preparation and loading method constitute the only modifications necessary for testing of dredged material in this device. Consolidation test procedures for use with soft dredged materials are outlined below; more detailed procedures are provided in USACE (1987), Poindexter (1988), Poindexter-Rollings (1990), and Palermo, Montgomery, and Poindexter (1978), and troubleshooting tips are provided in Rollings and Rollings (1996). Although the foundation soils under dredged



Figure I1. Standard oedometer testing device

material mounds are generally stiffer than dredged sediments, they are usually still categorized as soft soils within the geotechnical community. Therefore, it is prudent to test the foundation soils in the fixed ring device, although the standard loading sequence may be used.

A representative sample of the fine-grained (minus No. 40 sieve) portion of sediments to be dredged should be used for the standard oedometer test. Since sediments have typically been remolded during the dredging process and any internal structure existing in situ in the channel has been destroyed, a remolded sample can be used for this test. The samples of foundation soils for consolidation testing, however, should be undisturbed.

When soft disturbed sediment samples are used, they are often spooned into the consolidation device. In this case, the dredged material must be placed carefully into the consolidometer to prevent inclusion of air bubbles that would invalidate the test results. After the sample is placed in the consolidation ring in the oedometer, the initial load is applied. The seating load consisting of the porous stone, loading plate, and ball bearings plus the compression load caused by the dial indicator is considered as the initial load increment for the test. This load should not exceed 0.005 tsf. If the sample consistency is extremely fluid-like, a lower initial load may be necessary to prevent extrusion of the soft material from the consolidation ring.

Succeeding load increments may be placed using the normal beam and weight or pneumatic loading devices. The following loading schedule is typically used for dredged material testing: 0.005, 0.01, 0.02, 0.05, 0.10, 0.25, 0.50, and 1.0 tsf. A maximum load of 1.0 tsf should be adequate for most applications. However, the maximum effective stress anticipated to occur at the bottom of the dredged material deposit during its existence should be estimated and the loading sequence extended, if necessary, to cover the full range of potential effective stresses.

Time-consolidation data should be examined while the test is in progress to ensure that 100-percent primary consolidation is reached for each load increment. In some cases, it may be necessary to allow each load increment to remain for a period of several days. Rebound loadings are not normally required since the dredged material will not typically be excavated after placement at a disposal site (USACE 1987).

Self-Weight Consolidation Test

A test device and testing procedure were developed by Cargill (1985 and 1986) to allow determination of the compressibility characteristics of dredged material at high void ratios. This test represents a modification to a testing procedure developed by Bromwell and Carrier (1979) for use in analyzing phosphate mining wastes. It is used to supplement the standard consolidation test in order to provide $e-\sigma'$ and $e-k$ data over the full range of anticipated void ratios and is especially useful for hopper or hydraulically dredged materials.

This test is useful for determining the upper portion of the void ratio-effective stress and void ratio-permeability relationships; it is presently the only method available to determine this needed information.

The self-weight testing device is shown in Figure I2. This device consists of an outer plexiglass cylinder that encircles a second plexiglass column composed of either 0.25- or 0.50-in.-thick rings. The device allows consolidation testing and subsequent incremental sampling of a specimen 6 in. in diameter and up to 12 in. high. The material tested in this device should consist of only the fine-grained portion of the sediment, i.e., that portion passing the No. 40 sieve. Use of only minus No. 40 material is necessary to prevent, or minimize, segregation of the coarser fraction from the high void ratio slurry being tested.

The sediment is mixed with water from the dredging site to form a slurry. In order to develop the entire $e-\sigma'$ relationship, this slurry should always be at a void ratio greater than the void ratio at zero effective stress, e_{oo} , which is the void ratio of the dredged material after sedimentation and before consolidation. The initial void ratios usually used in this test range from approximately 10.0 to 16.0.

The slurry is placed in the consolidometer, and it is allowed to undergo self-weight consolidation. Deformation versus time data are collected during the consolidation process. After the completion of primary consolidation, the test device is disassembled and the specimen is sampled at 0.25- or 0.50-in. intervals throughout its depth to obtain the necessary data to calculate void ratio, effective stress, and permeability values for the upper portion of the $e-\sigma'$ and $e-k$ curves.

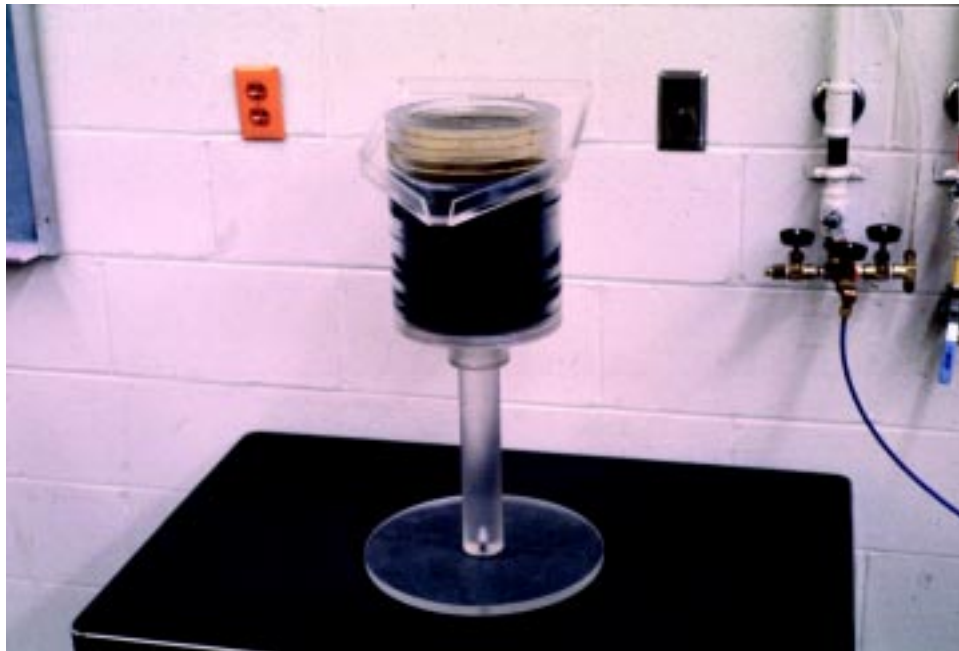

Figure I2. Self-weight consolidation test device

(Only one average value of k is obtained from this test.) Typical void ratios encountered in the specimen after completion of this test range from 5 to 12 (from bottom to top of specimen).

The self-weight consolidation test was developed to provide compressibility and permeability data for material that had been hydraulically dredged and placed in the disposal site as a slurry; thus the initial void ratios used in this test were required to be greater than the zero effective stress void ratio. Despite the fact that dredging methods other than hydraulic dredging will commonly be used for material placement at subaqueous disposal sites, continued use of this procedure will ensure that the e - σ' and e - k relationships developed for a particular material will cover the entire possible range of conditions.

Test Results

Both void ratio-effective stress and void ratio-permeability relationships must be developed from laboratory test results for each material (cap, contaminated dredged material, and foundation soil). These relationships should extend across the entire range of void ratios that may exist in each material. For dredged material, results obtained from the self-weight and oedometer tests (described in the previous section) must be combined to yield composite e - σ' and e - k relationships. For the stiffer foundation soils and some mechanically dredged materials, standard oedometer tests will typically provide adequate data. Tests needed for capping material will depend upon the type of material and its consistency; if sand is used for capping, no consolidation test will be required. Example compressibility and permeability curves are shown in Figures I3 through I8.

References

- Bromwell, L. G., and Carrier, W. D., III. (1979). "Consolidation of fine-grained mining wastes," *Proceedings of the Sixth Pan American Conference on Soil Mechanics and Foundation Engineering, Lima, Peru*.
- Cargill, K. W. (1985). "Mathematical model of the consolidation/desiccation process in dredged material," Technical Report D-85-4, U.S. Army Engineer Waterways Experiment Station, Vicksburg, MS.
- Cargill, K. W. (1986). "The large strain, controlled rate of strain (LSCRS) device for consolidation testing of soft, fine-grained soils," Technical Report GL-86-13, U.S. Army Engineer Waterways Experiment Station, Vicksburg, MS.
- Gibson, R. E., England, G. L., and Hussey, M. J. L. (1967). "The theory of one-dimensional consolidation of saturated clays, I. Finite, non-linear consolidation of thin homogeneous layers," *Geotechnique* 17, 261-273.

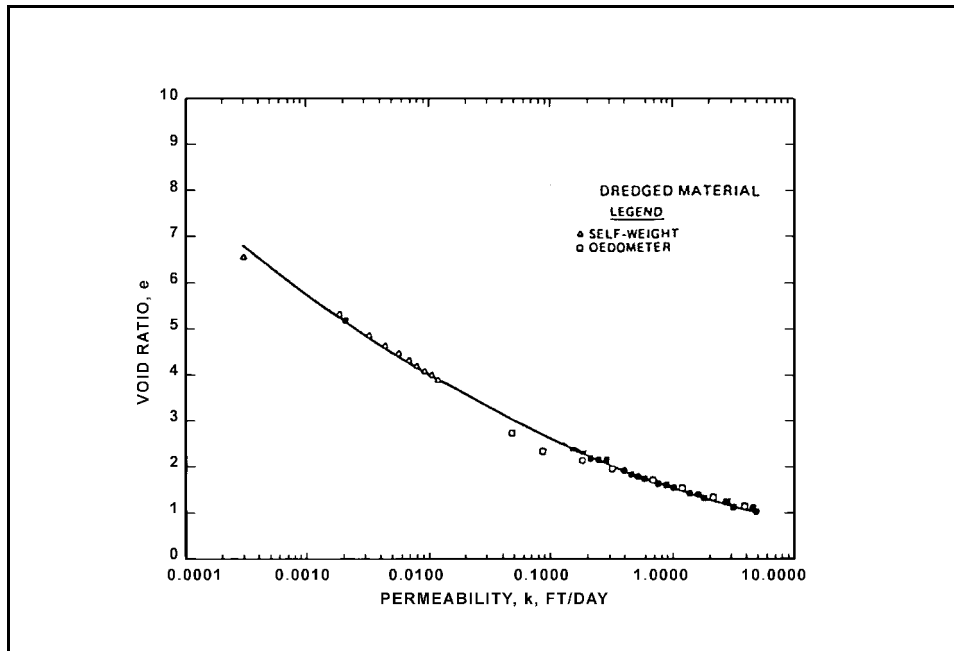

Figure I3. Void ratio-effective stress relationship for contaminated dredged material

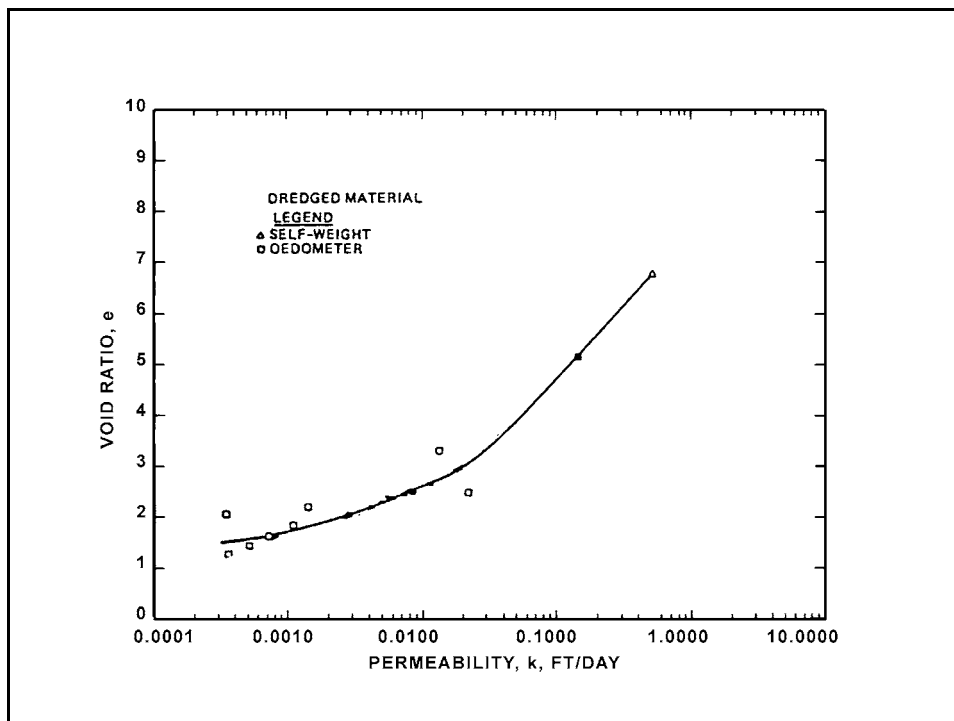

Figure I4. Void ratio-permeability relationship for contaminated dredged material

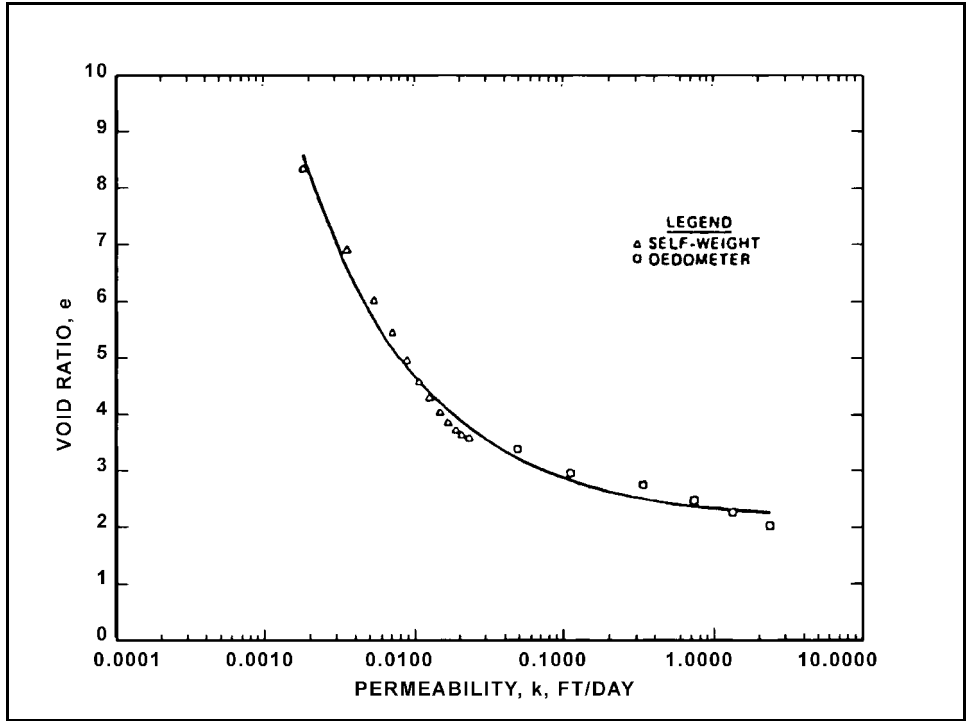

Figure I5. Void ratio-effective stress relationship for capping material

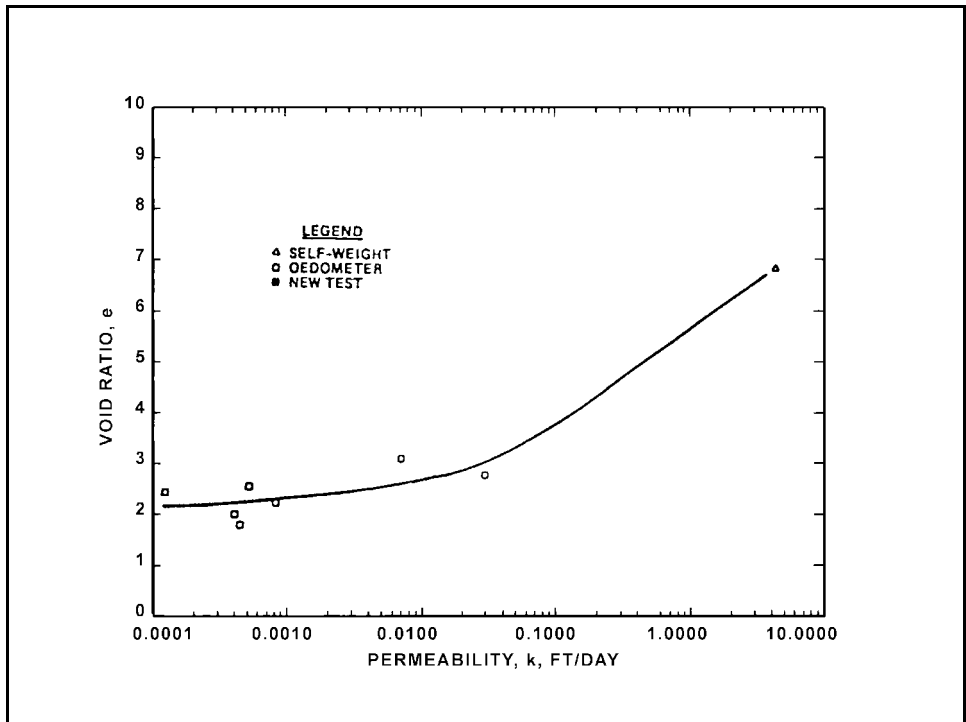

Figure I6. Void ratio-permeability relationship for capping material

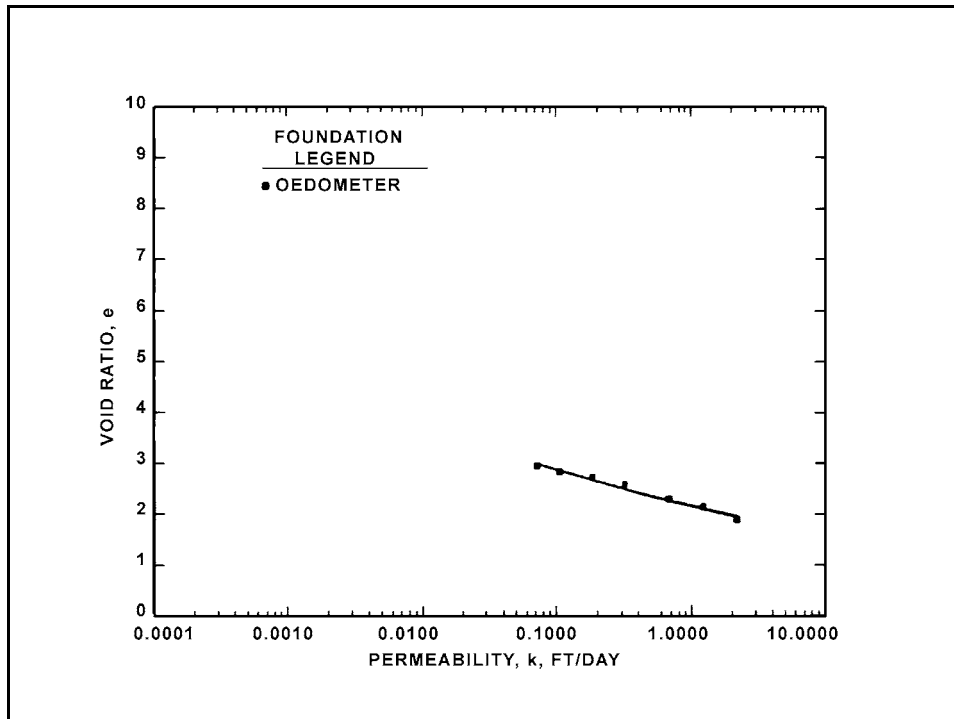

Figure 17. Void ratio-effective stress relationship for foundation soil

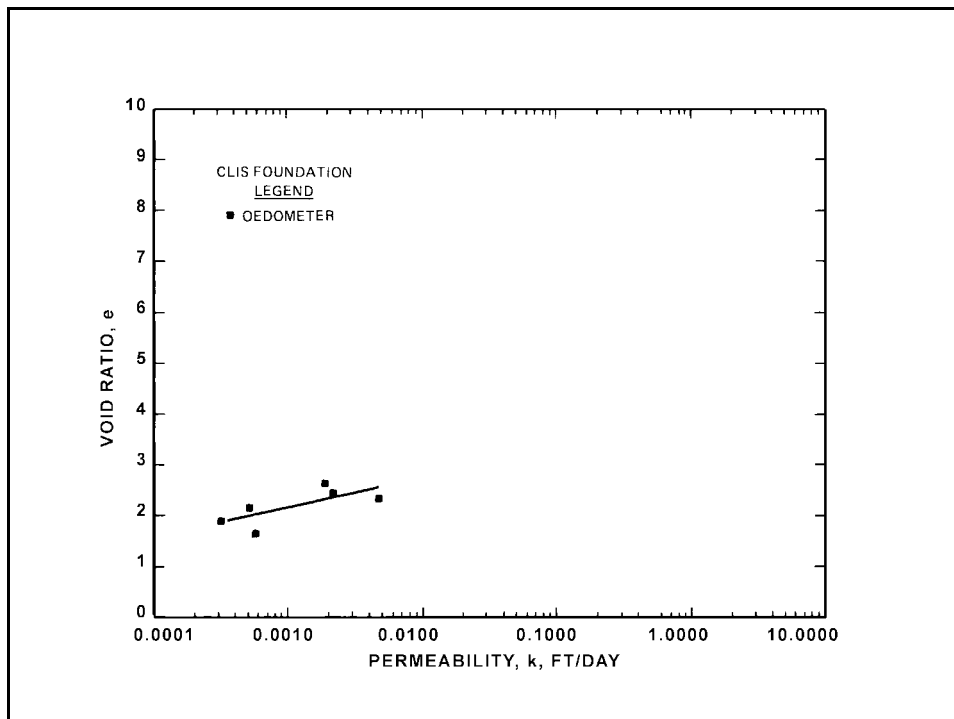

Figure 18. Void ratio-permeability relationship for foundation soil

- Gibson, R. E., Schiffman, R. L., and Cargill, K. W. (1981). "The theory of one-dimensional consolidation of saturated clays, II. Finite, non-linear consolidation of thick homogeneous layers," *Canadian Geotechnical Journal* 8, 280-293.
- Palermo, M. R., Montgomery, R. L., and Poindexter, M. E. (1978). "Guidelines for designing, operating, and managing dredged material containment areas," Technical Report DS-78-10, U.S. Army Engineer Waterways Experiment Station, Vicksburg, MS.
- Poindexter, M. E. (1988). "Behavior of subaqueous sediment mounds: Effect on disposal site capacity," Ph.D. Diss., Texas A&M University, College Station, TX.
- Poindexter-Rollings, M. E. (1990). "Methodology for analysis of subaqueous sediment mounds," Technical Report D-90-2, U.S. Army Engineer Waterways Experiment Station, Vicksburg, MS.
- Rollings and Rollings. (1996). *Geotechnical materials in construction*. McGraw-Hill, New York.
- Townsend, F. C. (1987). "Clay waste pond reclamation by sand/clay mix or capping," *ASCE Journal of Geotechnical Engineering* 115(11), New York.
- Townsend, F. C., and McVay, M. C. (1990). "State-of-the-art: Large strain consolidation predictions," *ASCE Journal of Geotechnical Engineering* 116(2), New York.
- U.S. Army Corps of Engineers. (1986). "Laboratory soils testing," Engineer Manual 1110-2-1906, Washington, DC.
- _____. (1987). "Confined disposal of dredged material," Engineer Manual 1110-2-5027, Washington, DC.

REPORT DOCUMENTATION PAGE			<i>Form Approved OMB No. 0704-0188</i>	
Public reporting burden for this collection of information is estimated to average 1 hour per response, including the time for reviewing instructions, searching existing data sources, gathering and maintaining the data needed, and completing and reviewing the collection of information. Send comments regarding this burden estimate or any other aspect of this collection of information, including suggestions for reducing this burden, to Washington Headquarters Services, Directorate for Information Operations and Reports, 1215 Jefferson Davis Highway, Suite 1204, Arlington, VA 22202-4302, and to the Office of Management and Budget, Paperwork Reduction Project (0704-0188), Washington, DC 20503.				
1. AGENCY USE ONLY (Leave blank)		2. REPORT DATE June 1998	3. REPORT TYPE AND DATES COVERED Final report	
4. TITLE AND SUBTITLE Guidance for Subaqueous Dredged Material Capping			5. FUNDING NUMBERS	
6. AUTHOR(S) Michael R. Palermo, James E. Clausner, Marian P. Rollings, Gregory L. Williams, Tommy E. Myers, Thomas J. Fredette, Robert E. Randall				
7. PERFORMING ORGANIZATION NAME(S) AND ADDRESS(ES) See reverse.			8. PERFORMING ORGANIZATION REPORT NUMBER Technical Report DOER-1	
9. SPONSORING/MONITORING AGENCY NAME(S) AND ADDRESS(ES) U.S. Army Corps of Engineers Washington, DC 20314-1000			10. SPONSORING/MONITORING AGENCY REPORT NUMBER	
11. SUPPLEMENTARY NOTES Available from National Technical Information Service, 5285 Port Royal Road, Springfield, VA 22161.				
12a. DISTRIBUTION/AVAILABILITY STATEMENT Approved for public release; distribution is unlimited.			12b. DISTRIBUTION CODE	
13. ABSTRACT (Maximum 200 words) <p>When dredged materials proposed for open-water placement are found to require isolation from the benthic environment due to the presence of contaminants, capping may be appropriate for consideration as a management action. This report is intended to provide technical guidance for evaluation of capping projects. From a technical perspective, this guidance is applicable to dredged material capping projects in ocean waters as well as inland and near-coastal waters.</p> <p>Subaqueous dredged material capping is the controlled, accurate placement of contaminated dredged material at an appropriately selected open-water placement site, followed by a covering or cap of suitable isolating material. A number of capping operations under a variety of placement conditions have been accomplished. Conventional placement equipment and techniques are frequently used for a capping project, but these practices must be controlled more precisely than for conventional placement. Level bottom capping (LBC) is defined as the placement of a contaminated material in a mounded configuration and the subsequent covering of the mound with clean sediment. Contained aquatic disposal is similar to LBC but with the additional provision of some form of lateral confinement (e.g., placement in natural bottom depressions, constructed subaqueous pits, or behind subaqueous berms) to minimize spread of the materials on the bottom.</p> <p style="text-align: right;">(Continued)</p>				
14. SUBJECT TERMS Capping Contaminated sediments			15. NUMBER OF PAGES 302	
Dredged material Open-water disposal Dredging			16. PRICE CODE	
17. SECURITY CLASSIFICATION OF REPORT UNCLASSIFIED	18. SECURITY CLASSIFICATION OF THIS PAGE UNCLASSIFIED	19. SECURITY CLASSIFICATION OF ABSTRACT	20. LIMITATION OF ABSTRACT	

7. (Concluded).

U.S. Army Engineer Waterways Experiment Station
3909 Halls Ferry Road, Vicksburg, MS 39180-6199;
U.S. Army Engineer District, New England
696 Virginia Road, Concord, MA 01742-2751;
Texas A&M University, College Station, TX 77843

13. (Concluded).

The main body of this report describes specific procedures for all aspects of capping project evaluation and design. A recommended sequence of design activities is presented, and specific design steps are organized into flowcharts as necessary. A number of appendixes are also included in this report that provide detailed information on specific testing procedures, predictive models, etc.

A capping operation must be treated as an engineered project with carefully considered design, construction, and monitoring to ensure that the design is adequate. There is a strong interdependence between all components of the design for a capping project. By following an efficient sequence of activities for design, unnecessary data collection and evaluations can be avoided, and a fully integrated design is obtained. The major components of the project design and evaluation process include site selection, equipment and placement techniques, geotechnical considerations, mixing and dispersion during placement, required capping sediment thickness, material spread and mounding during placement, cap stability, and monitoring. Processes influencing the cap design include bioturbation, consolidation, erosion, and potential for advection or diffusion of contaminants. The basic criterion for a successful capping operation is simply that the cap thickness required to isolate the contaminated material from the environment be successfully placed and maintained.

The cost of capping is generally lower than alternatives involving confined (diked) disposal facilities. The geochemical environment for subaqueous capping favors long-term stability of contaminants as compared with the upland environment where geochemical changes may favor increased mobility of contaminants. Capping is therefore an attractive alternative for disposal of contaminated sediments from both economic and environmental standpoints.