

FRANKLIN

engineering group, inc.

381 Riverside Drive, Suite 200
Franklin, TN 37064
615/591-0058 voice

**CLARIFIER WASTE TREATABILITY STUDY
PHASE 2 REPORT
PILOT PLANT DESIGN AND TESTING**

Prepared for:

Rhodia, Inc.
Silver Bow
119130 German Gulch Road
Butte, MT 59750

Prepared by:

Franklin Engineering Group, Inc.
381 Riverside Drive, Suite 200
Franklin, TN 37064

February 2011

TABLE OF CONTENTS

1.0 INTRODUCTION	4
2.0 PROCESS DESIGN	4
3.0 STILL TECHNOLOGY ALTERNATIVES AND ANCILLARY REQUIREMENTS	5
3.1 System Descriptions.....	5
3.1.1 American Process Systems (APS) Plow Blender	6
3.1.2 Advanced Thermal Solutions (ATS) Pan Processor	6
3.1.3 FEG-Designed Rotating Vessel Still.....	6
3.2 Condenser and Ancillary Equipment	10
4.0 PILOT PLANT DESCRIPTION	10
4.1 Overview.....	10
4.2 Major System Components.....	10
4.2.1 Pan Still.....	10
4.2.2 Condenser	11
4.2.3 Recirculation system	11
4.2.4 Control Systems	11
4.2.5 Furnace	12
4.3 Process Hazards Review.....	12
4.4 Operations Narrative.....	12
5.0 TEST RUNS OVERVIEW	13
5.1 Test Run #1	13
5.2 Test Run #2.....	14
5.3 Test Run #3.....	14
6.0 TEST RESULTS	14
6.1 Run #1	14
6.2 Run #2.....	14
6.3 Run #3.....	23
7.0 CONCLUSIONS	29
8.0 FUTURE PLANS	29
8.1 Control Room Improvements	29
8.2 Furnace and Still Improvements	30
8.3 Vapor Line Improvements	30
8.4 Nitrogen System Improvements	30
8.5 Condenser Improvements	30
8.6 Water Recycle System Improvements	30
9.0 PICTURES	31
10.0 PHR RECOMMENDATIONS	35
11.0 DRAWINGS	41

LIST OF FIGURES

Figure 1 APS Plow Blender Still Demonstration System.....	7
Figure 2 Advanced Thermal Systems Pan Processor Still Demonstration System	8
Figure 3 FEG Rotating Vessel Still Demonstration System.....	9
Figure 4 TCLP Analysis of Run #2 Residue	17
Figure 5 Phosphorus Analysis of Run #2 Residue	18
Figure 6 Run #2 Plot of Temperature Data.....	19
Figure 7 Run #2 Plot of Pressure Data	20
Figure 8 Run #2 Heat Balance.....	21
Figure 9 Run #2 Batch Summary Data Sheet	22
Figure 10 Run #3 Plot of Temperature Data.....	24
Figure 11 Run #3 Plot of Pressure Data	25
Figure 12 Run #3 Batch Summary Data Sheet	26
Figure 13 Run #3 Heat Balance	27
Figure 14 Run #3 Plot of Power-Temperature.....	28
Figure 15 PHR Recommendations Page 1.....	36
Figure 15 PHR Recommendations Page 2.....	37
Figure 15 PHR Recommendations Page 3.....	38
Figure 15 PHR Recommendations Page 4.....	39
Figure 15 PHR Recommendations Page 5.....	40

1.0 INTRODUCTION

The clarifier at the former Rhodia phosphorus manufacturing facility in Silver Bow, Montana contains approximately 500,000 gallons of solidified phosphorus-rich material. It contains 8 to 9 feet of phosphorus-rich material covered by more than 2 feet of water (the water cap). This material consists of elemental phosphorus (about 20% [v/v]), water and solids including phosphate dust, coke dust, and silica dust.

In 2007, Rhodia retained Franklin Engineering Group (FEG) to perform Phase 1 of a Treatability Study for this material. Phase 1 involved the compilation of process information for several candidate processes for treatment of the phosphorus-rich solids in the clarifier. A report summarizing the findings from the Phase 1 research was submitted in October 2007. The Phase 1 report was approved by the US Environmental Protection Agency (EPA) in February 2009. A joint decision was made between Rhodia, the Montana State Department of Environmental Quality (MDEQ), and the EPA to further evaluate batch still technology similar to that developed by Albright and Wilson (A&W) for evaporation and subsequent recovery of the phosphorus. This technology was chosen because it:

- Has proven to be effective in processing similar materials
- Allows Rhodia to recover the phosphorus contained in the clarifier
- Could be evaluated with pilot-scale equipment
- Reduces total volume of waste

In April 2009, Rhodia retained FEG to perform Phase 2 of the treatability study: a more thorough evaluation of the still-based phosphorus recovery process. This evaluation included reviewing available processing systems, selecting the most appropriate system for testing, system design and operation. This report describes the various options reviewed for the type of vessel (still) available to vaporize the phosphorus, describes the actual pilot plant design, and presents test results and data from the 2010 operation of the pilot plant.

2.0 PROCESS DESIGN

The evaluation began with a literature search to establish the required vaporizer (still) operating temperature. Butte, MT is at an elevation of 5,545 ft above sea level so the vaporization temperatures were adjusted from 14.7 psia to 11.95 psia using vapor pressure equations. At this pressure, phosphorus vaporizes at approximately 503 °F. At this temperature, a portion of the white phosphorus is expected to polymerize to the more stable amorphous red phosphorus. Red phosphorus must be heated to approximately 731 °F at 11.95 psia before it will sublime to form phosphorus vapor. The 1975 A&W mud still patent and historical operating data indicate that the solids temperature may need to be as high as 1,110 °F before all the phosphorus is vaporized. This discrepancy may be related to heat transfer through the static bed of the A & W mud still and it will be resolved during testing.

The original A&W mud still system utilized electric heating elements to melt a lead bath. Molten lead was used as both the heat transfer medium, and as a liquid seal to prevent the phosphorus vapor from escaping from the joint between the still lid and still vessel.

FEG and Rhodia personnel identified 3 different still designs as candidates for testing with the intent of selecting one technology for testing an evaluation. Each uses a different heating system. The heating systems include direct-contact electrical tracing, electric heat with molten salt as a heat transfer medium, and convection heating using combustion exhaust gas. (Conventional organic heat transfer fluids were excluded from the evaluation since they are only recommended for temperatures below approximately 750 °F.) A description of each still design is presented below in Section 3.0.

The system includes, besides the phosphorus vaporization still, additional components for recovery of the phosphorus. The entire system is shown in the Process Flow Diagram and Heat and Material Balance Drawing #721-101. A direct-contact water spray condenser will be utilized to condense the water and phosphorus vapor from the still. The condenser is based on the Rhodia design used for the original A&W mud still system. The vent gas from the still will flow upward through the condenser, counter-current to the downward water spray. Multiple spray nozzles are used to optimize condenser performance. The condensed phosphorus accumulates in the bottom of the condenser where it is periodically drained into a collection container in a water-filled drum. Each run should recover approximately 5.5 gallons of phosphorus. The condenser cone is maintained above the freezing point of phosphorus using steam or electric heat tracing. An eductor is fitted to the condenser vent to regulate system pressure and maintain a draft through the condenser.

Condenser spray water is recirculated, with makeup water added as needed to control system temperature. Makeup water can either be potable water, or it can come from the clarifier. A makeup water rate of about 2 gpm is anticipated, with a similar blowdown flowrate circulated back to the clarifier.

Condenser circulation, makeup water, and blowdown flowrates are designed for a maximum condenser effluent temperature of 140 °F. The vapor pressure of phosphorus is 0.009 psia at 140 °F. The mass balance indicates that approximately 0.09 lb/batch of phosphorus vapor will be vented from the condenser vent to the atmosphere during the pilot test; however, this does not account for any phosphorus entrainment that may be encountered due to condenser inefficiency.

3.0 STILL TECHNOLOGY ALTERNATIVES AND ANCILLARY REQUIREMENTS

The purpose of a pilot test study is to evaluate and select the best still technology for this application, and confirm the design basis for the condenser. Initial criteria to be evaluated include: energy usage, removal efficiency, cycle time, practicality of operation, quality of product recovered, and safety. The proven A&W mud still is considered a good system to use as an initial basis for design.

3.1 System Descriptions

The 3 candidate batch still processing systems are depicted in Figures 1-3. The testing was anticipated to occur on the existing concrete pad near the clarifier. The same condenser and supporting ancillary equipment can be used with all the stills. The stills have similar material capacity, approximately 3 cubic feet. All systems include a nitrogen sweep gas rate of 2 standard cubic feet per minute.

3.1.1 American Process Systems (APS) Plow Blender

Figure 1 depicts a system using an American Process Systems Plow Blender as a still. The device consists of a horizontal cylindrical vessel with a rotating plow to mix the solids and improve heat transfer. The plow is also used to direct solids to a discharge port after the batch is complete. The drum is directly heated using HTS/Amptek Duo-Tape® heating elements.

3.1.2 Advanced Thermal Solutions (ATS) Pan Processor

A full-sized A&W mud still was located in a warehouse in Columbia, TN. This unit would not be practical for testing purposes due to its large size. Advanced Thermal Solutions builds pan processors that are similar to the original A&W mud still. A demonstration system using the ATS Pan Processor is depicted by Figure 2. Their still is a vertical double-walled vessel with an internal mixing paddle. It is electrically heated and uses NaNO_2 salt as the heat transfer fluid. When approached about the Rhodia project, ATS reported they were currently resource-limited and could not actively participate in the testing program at the time. They do have a small test unit that can be purchased for the pilot tests. The unit would need some modifications for this application and reconditioning to make it operable.

3.1.3 FEG-Designed Rotating Vessel Still

Figure 3 shows a third type of still. This purpose-built device uses combustion gases to convectively heat a rotating drum that contains the clarifier sludge. The drum is supported by a tube that is used to carry inert gas (nitrogen) into the still, and convey nitrogen, water and phosphorus vapors out of the still. The drum is heated inside an insulated fire box fitted with a propane burner. An external electric motor rotates the drum to enhance mixing and improve heat transfer. Once vaporization is complete, the drum is removed from the fire box and placed on stands for cooling. The vessel hatch is be opened after it reaches an acceptable temperature and the contents discharged onto the ground. Additional drums would be used to increase throughput and shorten cycle time.

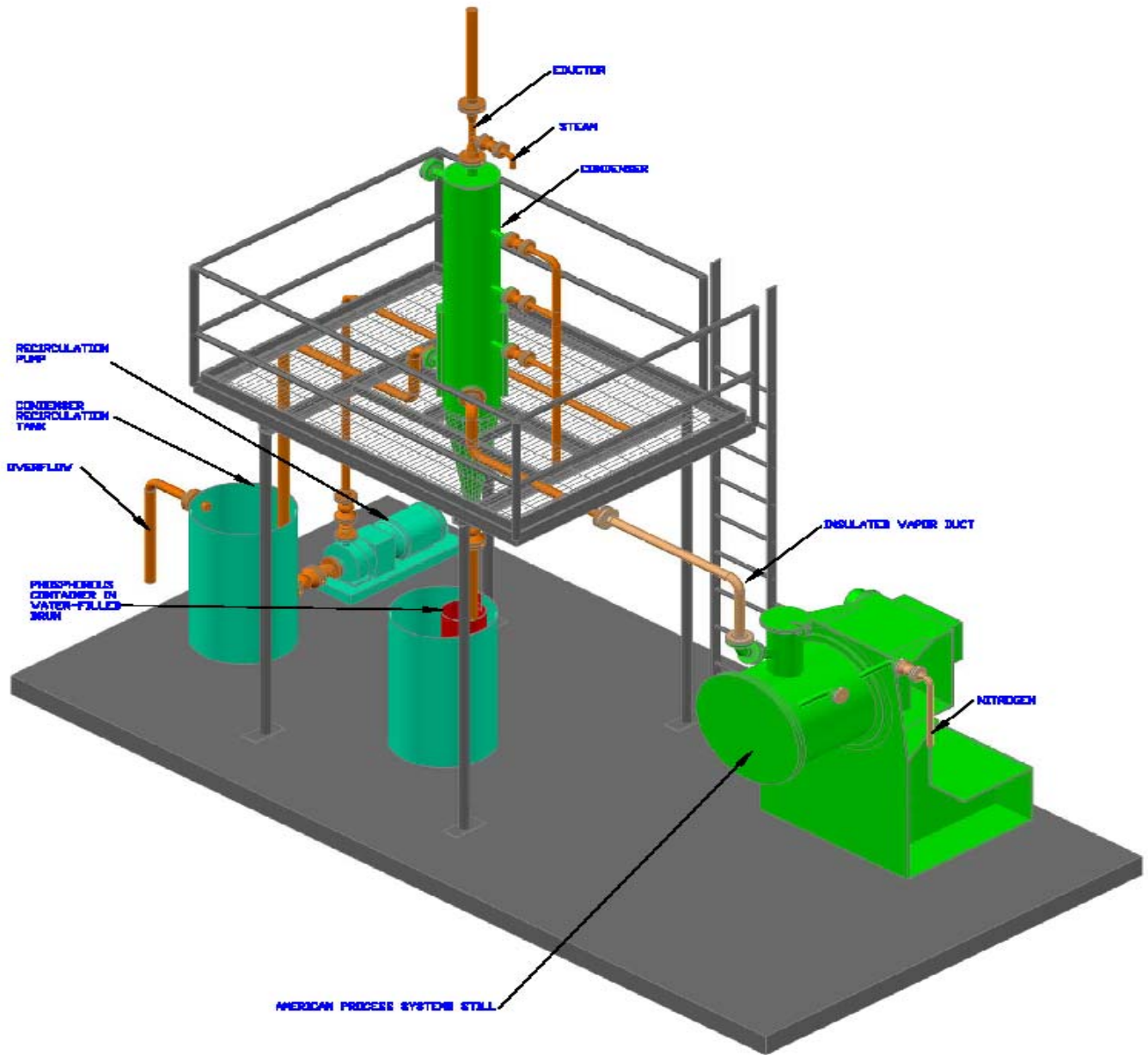

Figure 1 APS Plow Blender Still demonstration System

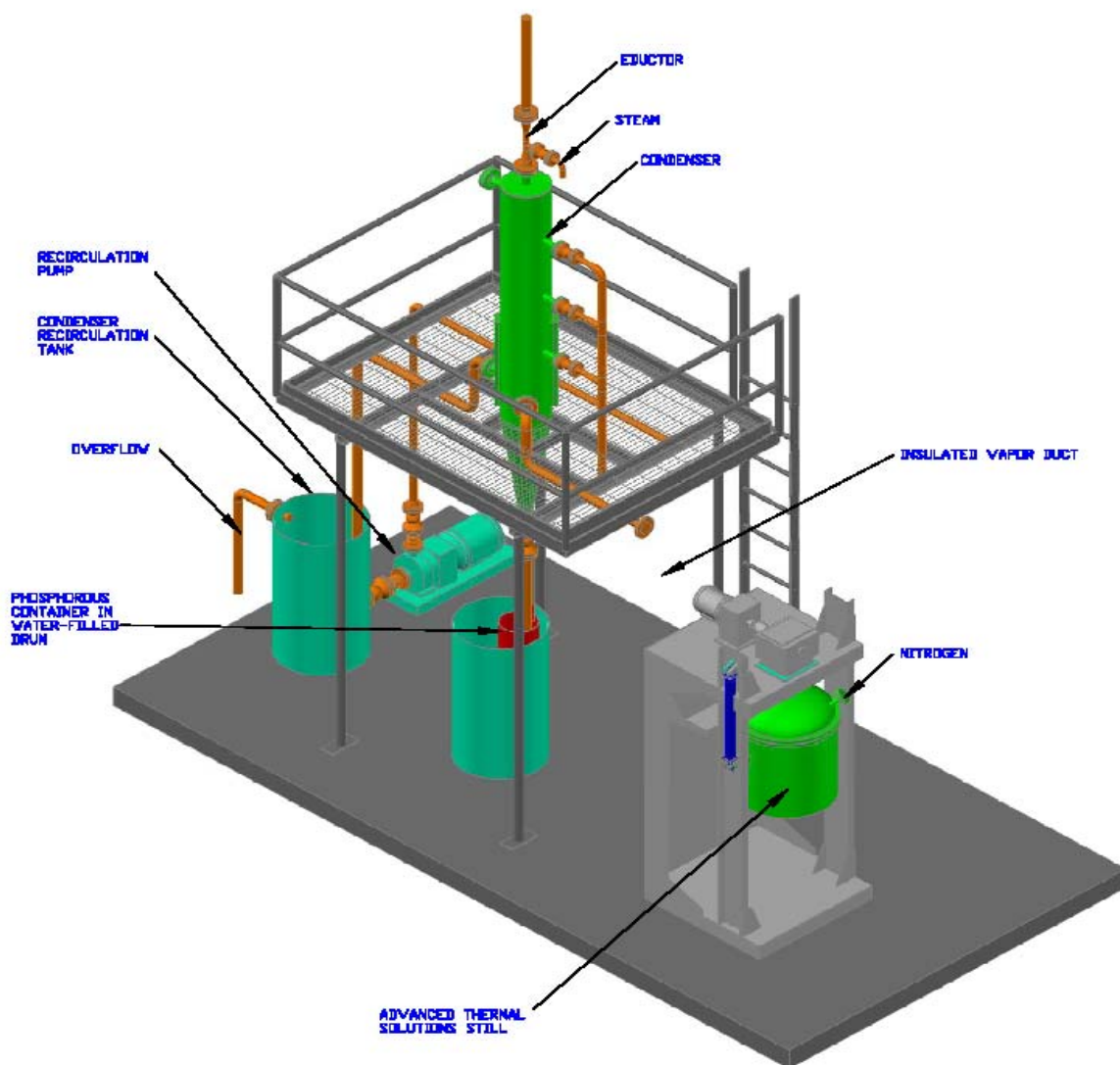

Figure 2 Advanced Thermal Systems Pan Processor Still Demonstration System

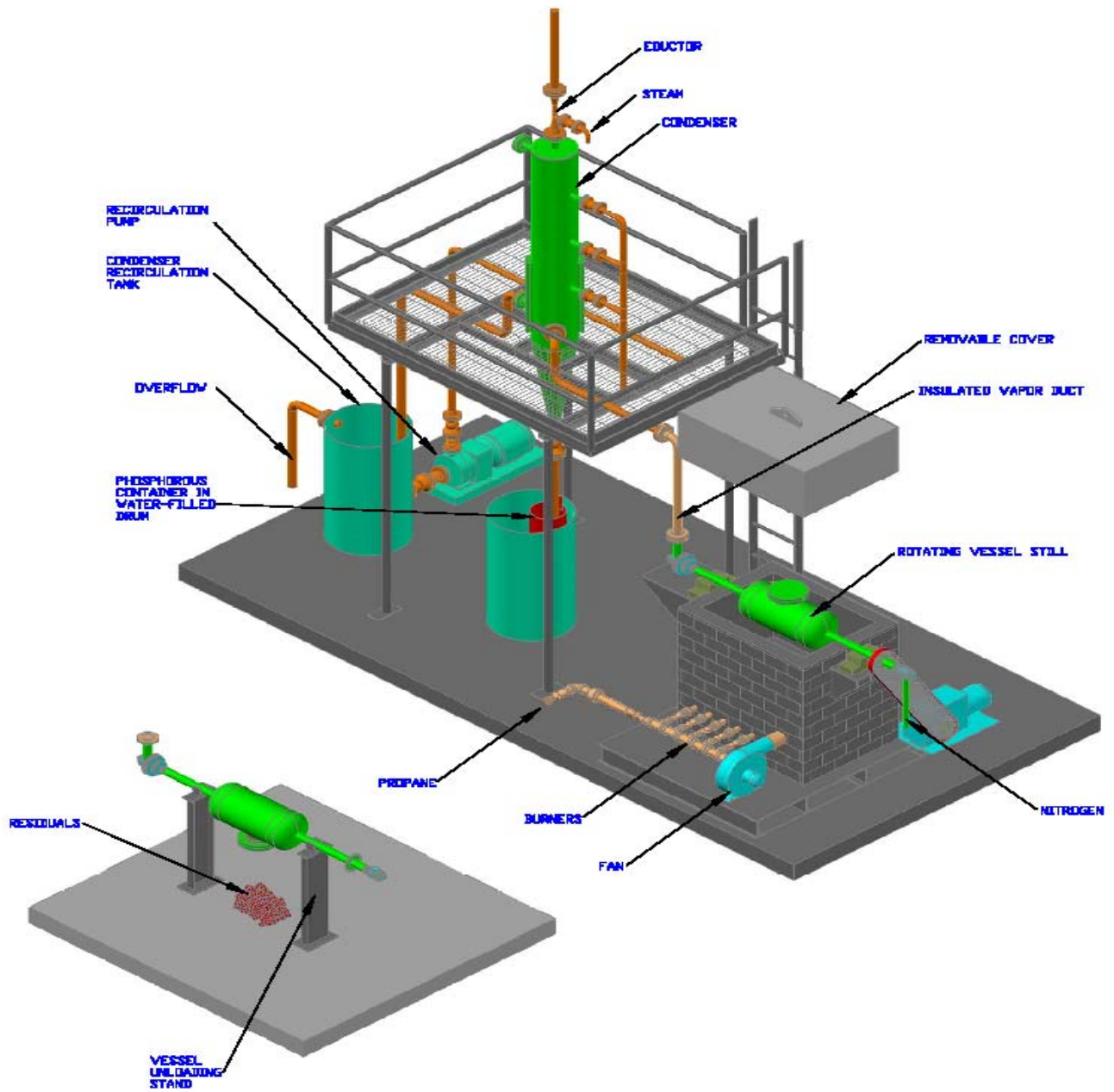

Figure 3 FEG rotating Vessel Still Demonstration System

3.2 Condenser and Ancillary Equipment

In addition to the vaporization still, the major ancillary components required for the pilot plant include:

- Direct-contact water spray condenser modeled after the Rhodia design
- Platform to support condenser
- Ducting for the vent gas and condenser overflow system
- Recirculation tank, pump, and piping for the condenser spray system
- N₂ cylinders for sweep gas
- Electricity supply for heating and equipment
- Condenser scrubber/eductor system
- Rental equipment
- Controls
- Data logger

4.0 PILOT PLANT DESCRIPTION

4.1 Overview

The still system that was chosen for the pilot plant was the Advanced Thermal Systems (ATS) Pan Processor. The ATS still design was thought to most closely resemble the proven A&W mud still technology. However, this unit was subsequently found to be unavailable. It was then decided to design and build a pan still similar to the ATS system.

The system consists of three functional sections: a stainless steel pan still with a separate 45 kW electric furnace to heat the sludge and vaporize the phosphorus, a stainless steel condenser to condense and recover phosphorus, and a stainless steel recirculation tank and pump to capture the overflow water from the condenser and recirculate back to the condenser. The overall process is shown on the attached Process Flow Diagram/Heat and Material Balance (Drawing # 721-101). A more detailed depiction of the process, with controls and instrumentation shown, is provided by the attached Piping & Instrumentation Diagram's (Drawing # 721-111 and 721-114).

4.2 Major System Components

4.2.1 Pan Still

The pan still design uses a section of 24" schedule 40, stainless steel pipe with a flat plate for a bottom and a stainless steel flange at the top for attaching a lid, shown in Drawing # 721-420. The design capacity for the still is 3 cubic feet of clarifier material per batch. The lid had a matching flange to mate up to the bottom section and seal the still during operation. The lid also was equipped with an agitator to enhance the heat and mass transfer efficiency of the still, shown in Drawing #721-421. The still assembly is placed within the electric furnace during operation.

4.2.2 Condenser

The condenser is a counter current flow, direct contact stainless steel vessel with three water nozzles that spray downward inside the condenser. The hot gases from the still enter through a side inlet near the bottom of the condenser, rise through the falling water spray, and exit through the vent at the top of the condenser. This gas flow is enhanced by a scrubber/eductor on the scrubber vent. The condensed phosphorus is recovered at the end of each batch from the bottom of the condenser and collected in a water filled drum. The condenser design is shown in Drawing # 721-401.

4.2.3 Recirculation system

The recirculation system consists of a stainless steel recirculation tank and pump to circulate heated process water through the system. The water overflow from the condenser is collected in the tank and recirculated back into the condensing system. Any phosphorus carryover from the condenser is collected in the bottom of the recirculating tank and drained into a water filled recovery drum at the end of the test. Any water overflow from the recirculating tank is returned to the clarifier. The recirculation tank design details are shown in Drawing # 721-402.

4.2.4 Control Systems

Key process variables are measured with field instrumentation. Instrument signals are sent to a data recorder for real-time monitoring and data recording.

There are two control loops used for controlling the system when in operation. The first control loop controls the electric furnace temperature to a setpoint entered manually by the operator through the front faceplate of the furnace controller. A thermocouple mounted on the furnace face is used by a Eurotherm controller to modulate silicon controlled rectifiers regulating the power to the heating elements of the furnace. The second control loop regulates the temperature of the recirculation water to the direct contact condenser by adjusting the amount of make-up water introduced into the recirculation line. A thermocouple mounted in the recirculation line is connected to a Red Lion controller outputting to a control valve in the make-up water supply line. The operator adjusts the temperature of the recirculation line water via the manually entered setpoint on faceplate of the Red Lion controller.

Pressure on the furnace/condenser system is controlled manually using a ball valve to adjust the flow of recirculation water to the scrubber/eductor on the top of the condenser. There are both electronic pressure transmitters and visual pressure indicators on the vapor line from the furnace and on the top gas exit line of the condenser immediately prior to the scrubber/eductor. These instruments are used by the operator to control the pressure in the vapor line from the furnace to near zero inches of water column pressure or slightly negative. The pressure is controlled near zero to minimize the possibility oxygen might be pulled into the system or phosphorus might be pushed out. Either condition would likely initiate a fire.

Heated nitrogen is introduced to the furnace vapor space to act as a carrier gas for the phosphorus vapors. The nitrogen is introduced at the packing gland for the agitator (when present) and through a nozzle on the furnace lid. The nitrogen supply is from a nitrogen cylinder under pressure. The cylinder pressure is reduced using a pressure

reduction valve to a level appropriate for the furnace. The flow rate of gas is regulated by two rotometers, one for each supply point to the still.

4.2.5 Furnace

The electric furnace is from Mellen, a supplier of commercial furnace products. The furnace is capable of supplying 45 kW of power input to heat the still to a maximum operating temperature of 1400°F. The furnace system is supplied complete with a Eurotherm temperature controller and high temperature cutoff.

4.3 Process Hazards Review

Construction of the pilot plant was completed in early August of 2010. Following commissioning activities, a comprehensive Process Hazards Review was completed. The purpose of this process/procedural hazard review was to determine if the Phosphorus Pilot Recovery System as designed and constructed could safely recover phosphorus from the clarifier material. An additional objective was to determine if adequate safeguards had been specified in the process design to detect, prevent, or mitigate releases and other non-standard operating events. Industrial hygiene, ergonomic and personnel protection requirements for each specific task were reviewed.

Rhodia was represented by the Silver Bow Site Manger and Environmental, Safety and Health Manager. The engineering and design Project Manager from Franklin Engineering Group (FEG) attended the two day review. The Construction Manager, Field Superintendent and operating personnel from KASE/Warbonnet (KW) were in attendance to provide operating and procedural input. A professional facilitator with extensive phosphorus manufacturing experience was contracted to provide structure to the review and to provide a summary working document.

The design review was based on the Heat and Material Balance drawing provided by Franklin Engineering Group. The normal operating parameters and procedures for each of the eighteen process streams were evaluated separately and in relation to the system as a whole. Each of the normal operating parameters were then evaluated on a ‘what if’ deviation basis, ie. Flow: Higher than normal flow, lower than normal or no flow. Temperature: Higher than normal temperatures, lower than normal temperatures. Controls and safeguards were identified as well as system or procedural revisions. A Qualified Risk Matrix (QRM) was considered when warranted. The QRM adds a component of severity and likelihood to the process deviations.

A document was generated at the conclusion of the Process Hazards Review to record the group recommendations. Tracking completion of the recommendations was the responsibility of the construction group. A copy of the Process/Procedural Hazards Review Recommendations is include at the end of this report as Figure 15.

4.4 Operations Narrative

The following is a description of typical steps to process a batch of sludge from the clarifier through the pilot plant.

1. Sludge is removed from the clarifier using a small trackhoe and carefully loaded through a funnel/bin into the still bottom.
2. The sludge is allowed to settle and the excess water is decanted from the surface and returned to the clarifier. A thin layer of water is left to cover the clarifier sludge to prevent burning.
3. The loaded still bottom is moved to the maintenance area/spill pan next to the clarifier.
4. The still lid with agitator is lifted and placed on top of the still bottom and the bolts installed and torqued to specification.
5. The loaded still assembly is placed on the platform scale to record the beginning weight for the batch.
6. The loaded still is then placed into the furnace frame and secured with bolts.
7. Process connections are made between the still, condenser system, and the nitrogen purge/vent piping.
8. The condensing and recirculation system heat tracing and tank heaters are energized to bring and maintain the system within an acceptable temperature range (120-140°F).
9. The thermocouples on the furnace are re-installed and connected to the data recorder input wiring.
10. The furnace is energized and heat applied in a controlled fashion to bring the temperature in the still up to the set point temperatures.
11. During the heat up, the pressures and temperatures of the condensing and recirculation system are monitored and adjusted to stay within process limits.
12. The still vapor line temperature is monitored as a basis for predicting the start and end of the water and phosphorus vapor phases. Once the vapor line temperature is judged to indicate the phosphorus has been vaporized, the furnace is turned off and the system allowed to cool overnight.
13. The connections between the still, condenser system, and nitrogen/vent piping are removed.
14. The still is lifted from the furnace frame, weighed to determine batch final weight, and moved to the maintenance area/spill pan next to the clarifier.
15. The bolts are removed and the lid is removed. (If any phosphorus remains, water is added to suppress fires/smoke and the still is cleaned.)
16. The phosphorus that was vaporized and then condensed in the condenser is drained into a drum through a ball valve on the bottom of the condenser. The drum is located inside an oversized drum of heated water.
17. The product drum is then removed and weighed to determine how much phosphorus was distilled.
18. Any phosphorus collected in the recirculation tank is also drained into a drum and weighed.
19. The system is then cleaned with hot water flushes to remove any residual phosphorus and prepare for the next batch.

5.0 TEST RUNS OVERVIEW

5.1 Test Run #1

Run #1 was performed on August 31, 2010 with the batch size of approximately one half the design capacity of the still (batch weight = 193 lbs). This run was made without the agitator installed in the lid of the still and the agitator mounting flange was covered with a blind flange. There was visible phosphorus remaining in the central area of the still at the end of the batch with a muddy crust on the still wall. This run illuminated several areas within the system that could be improved prior to the next run. These included:

- Agitation - Agitation may be necessary for heat and mass transfer to be successfully accomplished in a timely manner so an agitator will be installed.
- Insulation - Various areas of the still and condenser system needed insulation for improved heat retention and to prevent condensing and buildup of phosphorus.
- Maintenance - Modifications to allow for easier maintenance and cleanup of the system after each batch were needed.
- Temperature Control - The condenser system temperature needed to be controlled within the range of 120-140°F for the phosphorus to properly settle and collect in the condenser.
- Metering – Monitoring and recording furnace power usage is important so a meter to record the furnace power usage will be added.

5.2 Test Run #2

After the improvements identified in run #1 were implemented, run #2 was performed on September 13, 2010. This batch size was also approximately one half the design capacity of the still (batch weight = 221 lbs). The furnace setpoint was raised in a stepwise fashion throughout the batch. This batch was successful with the residue contents of the still being visually phosphorus free. The amount of phosphorus collected from the condenser and the recirculation tank was within the anticipated range.

5.3 Test Run #3

Run #3 was performed on September 21, 2010 with the batch size near the full design capacity of the still (batch size = 342 lbs). The furnace setpoint was raised to 1200°F at the beginning of the batch and held there throughout the batch. There was significant phosphorus remaining in the residue of the still at the end of the batch requiring water quenching when the lid was removed. Analysis of run #3 process information indicates the residual phosphorus resulted from an incomplete run where the time and temperature required to vaporize all red phosphorus was not achieved.

6.0 TEST RESULTS

6.1 Run #1

Agitation, insulation, and maintenance issues with run #1, combined with significant white phosphorus remaining in the residue, eliminated fruitful discussion of the process data. Run #1 will not be presented in the results discussion because of these issues. As required by the test plan, all material from run #1 was returned to the clarifier.

6.2 Run #2

Run #2 was the only run in which the phosphorus was completely vaporized and so it presented the only sample of residue that could be analyzed for elemental phosphorus and TCLP metals. Those analyses are attached as Figure 4 and Figure 5. The residue did not smoke or ignite as it contained only 0.0016 mg/kg elemental phosphorus. The residue failed the TCLP analysis for cadmium as 1 mg/L is the limit for non-hazardous waste and 2.13 mg/L was the measured value. The residue was stored on the Hazardous Waste Storage area on site, and shipped off site for hazardous waste (i.e., D006) disposal within the 90 day storage period.

The trend plot of the temperature data from run #2 (Figure 6) shows the recorded temperatures for the batch. The top red line is the furnace temperature with the stepwise ramp-up during the batch reaching the final maximum of 1350°F. The lower blue line is the still vapor line temperature and reveals the most information about what is happening within the batch. The still contents temperature is not directly measured but can be deduced from the vapor line temperature.

Initially the still vapor line temperature is steady at ~200°F which corresponds to approximately the boiling point of water at altitude. As the still contents temperature increases and the amount of water in the still diminishes, the vapor temperature slowly increases until there is not enough vapor flow to carry heat up to the temperature sensor in the still vapor line (~ 2:56PM). The vapor line temperature then slowly drops for the next hour and a half as the still contents temperature increases to the boiling point of white phosphorus (~560°F).

When phosphorus vaporizes in significant quantities, the temperature rises quickly to ~480°F and remains there as long as there is enough phosphorus being vaporized (~5:30PM). The vapor line temperature then drops again as the vapor flow from the still is too low to carry the heat from the still to the temperature sensor in the vapor line. The vapor line temperature continues to drop for the next 45 minutes as the still contents temperature increases to the vaporization point of red phosphorus.

When red phosphorus vaporizes in significant quantities, the vapor line temperature rises quickly again to ~460°F. After the red phosphorus is exhausted from the still, the vapor line temperature gradually falls again as there is not enough vapor to carry the heat from the furnace to the temperature sensor. The red phosphorus present is believed to have been produced by conversion of the white phosphorus into red during the heat up prior to vaporization of the white phosphorus. The two temperature rises from the white and red phosphorus are indicated by two humps on the temperature chart for the vapor temperature line. The relative size of the two humps is a crude approximation of the ratio of white to red phosphorus in the batch. As expected, the white phosphorus hump is significantly larger than the red phosphorus hump.

The trend plot of the pressure data from run #2 (Figure 7) shows the recorded vapor line and condenser outlet pressures for the batch. There are several excursions of the pressure from the control point (slightly positive for the vapor pressure line), but none of these are thought to have any significant impact on the process.

The batch time for run #2 (a half batch) was 10 hours 10 minutes, which is longer than estimated on the original Heat and Material Balance (HMB) for a full batch. There are likely two major factors for the extended cycle time; the amount of water that is retained in the batch charge even after decanting, and the degree of agitation particularly near the wall of the still. The original HMB estimated the still feed after decanting as ~15% by weight water. The summary sheet for run #2 (Figure 9) indicates the still feed after decanting actually to be ~62% by weight water. This additional water is a large heat requirement for the system and must be removed before any phosphorus can be vaporized. A simple heat balance for run #2 (Figure 8) indicates that approximately 79% of the BTU's used by the process were used to heat and vaporize the water. Batch #1 and #2 had a small amount of fouling on the inside wall of the still but batch #3 showed a significant fouling layer. Since the vertical side walls

of the still are the only direct heating surface for the system (no direct heating on the bottom), any fouling on those surfaces would significantly affect heat transfer into the still.



IAS — ENVIRO CHEM
 3314 Pole Line Road • Pocatello, Idaho 83201
 Phone: (208) 237-3300 • Fax: (208) 237-3336
 Email: iasec3308@iasenvirochem.com

EnviroChem

INDUSTRIAL - WATER - WASTE - SOIL - GEOCHEMICAL - FIRE ASSAY - QA/QC

Kase Warbonnet Inc.
 Mark R. Smith
 1477 Thunderbolt
 Pocatello, ID 83204

Date Submitted: 9/17/2010
 Date Reported: 9/28/2010

Certificate of Analysis

Sample Description:	Clarifier Matl					
Sampling Date:	9/17/2010					
Sampling Time:	00:00					
Date Received:	9/17/2010					
Lab Tracking #:	I009128-01					
	<u>Analyte</u>	<u>Result</u>	<u>Units</u>	<u>Method</u>	<u>Analyzed</u>	<u>Analyst</u>
	TCLP Arsenic	< 0.05	mg/L	1311/6020A	9/22/2010	RP
	TCLP Barium	0.40	mg/L	1311/6020A	9/22/2010	RP
	TCLP Cadmium	2.13	mg/L	1311/6020A	9/22/2010	RP
	TCLP Chromium	0.08	mg/L	1311/6020A	9/22/2010	RP
	TCLP Lead	0.87	mg/L	1311/6020A	9/22/2010	RP
	TCLP Mercury	< 0.01	mg/L	1311/6020A	9/22/2010	RP
	TCLP Selenium	< 0.05	mg/L	1311/6020A	9/22/2010	RP
	TCLP Silver	< 0.05	mg/L	1311/6020A	9/22/2010	RP

G. Ryan Pattie
 Laboratory Director

Figure 4 TLCP Analysis of Run #2 Residue

Kase Warbonnet Inc.
 Mark R. Smith
 1477 Thunderbolt
 Pocatello, ID 83204

Date Submitted: 09/28/2010
 Date Reported: 10/15/2010

Certificate of Analysis

Sample Description:	Clarifier Matl					
Sampling Date:	9/17/2010					
Sampling Time:	00:00					
Date Received:	9/28/2010					
Lab Tracking #:	I009208-01					
<u>Analyte</u>	<u>Result</u>	<u>Units</u>	<u>RL</u>	<u>Method</u>	<u>Analyzed</u>	<u>Analyst</u>
Total Phosphate as P	9.64	%	0.50	Gravimetric	09/29/2010	GRP
White phosphorus	1.6	ug/kg	0.50	EPA 7580	10/13/2010	SUB

ND = Not Detected



G. Ryan Pattie For G Ryan Pattie
 Laboratory Director

Figure 5 Phosphorus Analysis of Run #2 Residue

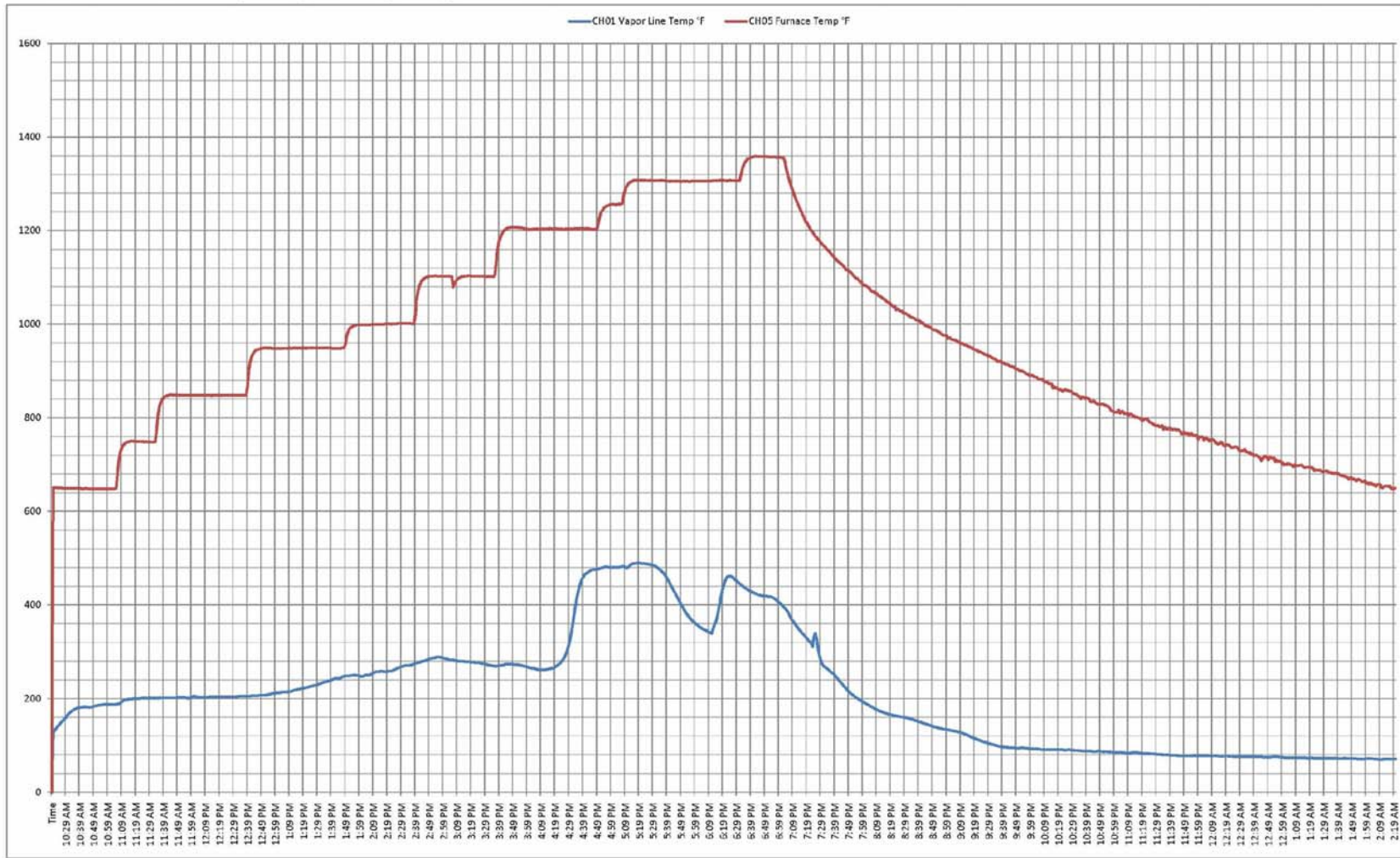

Figure 6 Run #2 Plot of Temperature Data

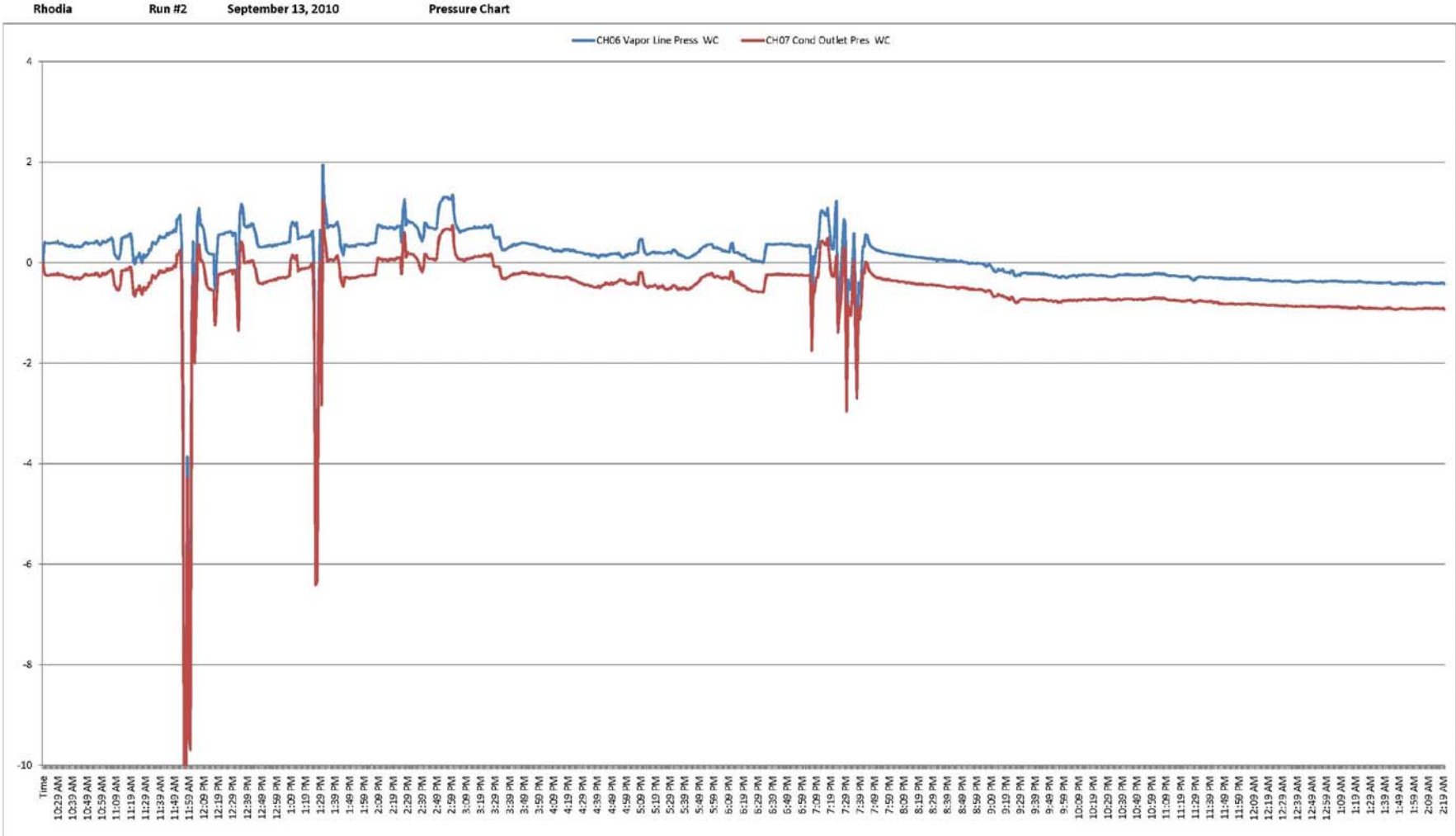

Figure 7 Run #2 Plot of Pressure Data

Heat and Material Balance for Run #2

Assumptions and Physical Properties:

1. All of the water was vaporized from the still.
2. The material balance information is from the run #2 operations summary sheet.
3. The total heat consumed for run #2 was 118.5 kWh or 404,338 BTU, from the summary log
4. The water is heated to 202 DegF before vaporization occurs.
5. The phosphorus is heated to 400 DegF before vaporization occurs.
6. The soil/silt that remains in the still is heated to ~600 DegF prior to turning off the furnace.
7. The stainless steel components of the still are heated to an average of ~600 DegF.
8. The initial temperature of the batch is 55 DegF.
9. Calculated weight of the 316SS still is ~456 lbs

Physical properties:

	Heat Capacity (BTU/lb DegF)	Heat of Vap. (BTU/lb)
Soil/Silt	0.2	N/A
Phosphorus	0.184	172
Water	1	970
316 SS	0.12	N/A

Material Balance Summary:

Total Batch Weight	221 lbs
Water	136 lbs
Phosphorus Recovered	18 lbs
Soil/Silt/Phos remaining in still	67 lbs

Heat Required to Recover the Water:

BTU's to heat the water to boiling=	19,992 BTU (5.86 kWh)
BTU's to vaporize the water=	131,920 BTU (38.7 kWh)
Total to process water=	151,912 BTU (44.5 kWh)
% of total process heat=	79%

Heat Required to Recover the Phos.:

BTU's to heat the Phos. to vap. Temp.=	1,143 BTU (0.33 kWh)
BTU's to vaporize the Phos.=	3,096 BTU (0.91 kWh)
Total to process Phos.=	4,239 BTU (1.24 kWh)
% of total process heat=	2%

Heat Required for Still Residue:

Heat Required to heat up the silt/soil=	7,303 BTU (2.14 kWh)
% of total process heat=	4%

Heat Required for Still:

Heat required to heat the 316SS Still=	29,822 BTU (8.74 kWh)
% of total process heat=	15%

Total heat accounted for by the process= 193,276 BTU (56.6 kWh)

Total heat lost through system inefficiencies= 211,062 BTU (61.9 kWh)

Percent heat lost to inefficiencies= 52%

Figure 8 Run #2 Heat Balance

Rhodia Pilot Phosphorus Recovery System

Batch Summary Data Sheet

Batch No. 02
 Date 9/13/2010 Day Monday
 Weather Low 34, high 75, mostly sunny
 Operators Keller, Freeman, Whiteus

Miscellaneous Information

Clarifier Material Sample Location Clarifier Southside

Approximate Sample Depth 8' below water

Batch Start Information

Pan Still Gross	Pan Still Wt.	Net Batch Wt.
1404	1183	221

Batch End Information

Pan Still Gross	Pan Still Wt.	Net Residue Wt.
1250	1183	67

KWH Meter Reading - Start of Batch 140.0

KWH Meter Reading - End of Batch 258.5

KWH Consumed for Batch 118.5

Furnace Ramp Rate
0-500 F for 1 hour
500-650 F for 1 hour (or more)
650-1000 F @ 100F/30 minutes
Overflow @ 11:20, Furnace 750 deg F. Vapor line at 200 deg F

Batch Start Time 8:50 AM

Batch End Time 7:00 PM

Batch Run Time 10:10 hours:minutes

N2 Supply Start 1800 / 2400

N2 Supply End 0 / 500

N2 Consumed 203+240=443 cf

Product Container Start Weight 208

Product Container End Weight 225

Product Produced (Pounds) 17

TK-100 Start 62

TK-100 End 63

P4 (Pounds) 1

		% of Batch
Net Batch Weight (from above)	221	100.00%
Net Residue Weight (from above)	67	30.32%
Product Produced - Pounds	18	8.14%
Net Water Evaporated - Pounds	136	61.54%

Figure 9 Run #2 Batch Summary Data Sheet

6.3 Run #3

Since run #3 did not vaporize all of the phosphorus from the batch, it was not possible to sample or analyze the residue in the still. As required in the Pilot Test Waste Plan, all of the residue from the run #3 was returned to the clarifier.

The trend plot of the temperature data from run #3 (Figure 10) shows the recorded temperatures for the batch. The furnace temperature is set to 1200°F at the beginning of the batch and remains there for the duration of the batch. The vent line temperature presents a similar profile to the run #2 vent line temperature for the same reasons. The one significant difference is the absence of the second phosphorus rapid temperature rise, indicating that the boiling point for red phosphorus was not reached in the still. This was confirmed by the significant amounts of red phosphorus remaining in the still residue. The other temperatures shown on the chart record the vent and scrubber operation, which were fairly stable during the run.

The trend plot of the pressure data from run #3 (Figure 11) shows the recorded pressures for the batch. There are a few pressure excursions from the control point (slightly positive for the vapor pressure line), but none are thought to have any significant impact on the process.

The batch time for run #3 was 10 hours, almost the same as run #2. However, run#3 had a larger batch size and did not completely vaporize all of the phosphorus. This was probably mostly due to an incomplete batch cycle. The batch composition was similar to run #2 with ~ 54% (run #3 summary sheet – Figure 12) water vs. ~62% (run #2). A simple heat balance for run #3 (Figure 13) shows that approximately 80% of the BTU's used by the process were used to heat and vaporize the water. The walls of the still were coated in a muddy cake of material.

As an operational improvement from run #2, the power meter readings were recorded on the operation log for run #3. This allows an analysis of power usage through the batch. This power data has been plotted with the vapor line temperature and furnace temperature (Figure 14). From ~11:30 through to the end of the batch, the slope of the power line is constant, indicating constant power draw by the furnace to hold the 1200°F setpoint. The entire white phosphorus temperature rise on the vapor line occurs during this constant power draw. This is consistent with the simple heat balance for run #3 as the vaporization of the phosphorus uses only ~4800 BTU (1.4 kWh). This would not be enough of a heat sink to be seen in the power usage above the noise and inefficiencies inherent in the system. The kilowatt-hours used per pound of phosphorus processed through the pilot plant is affected mostly by the amount of water in the feed and secondly by the heat transfer inefficiencies inherent in the system.

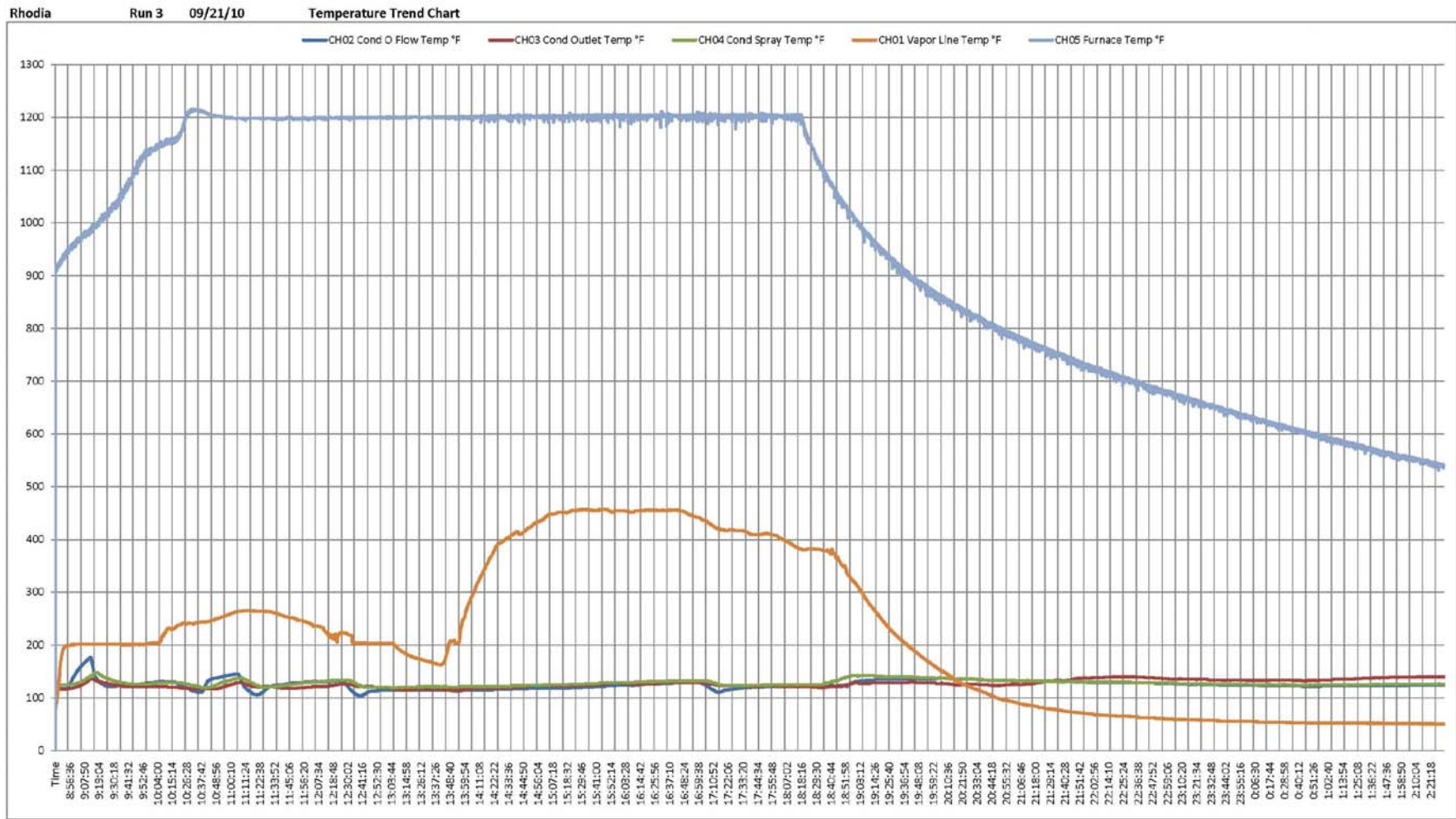

Figure 10 Run #3 Plot of Temperature Data

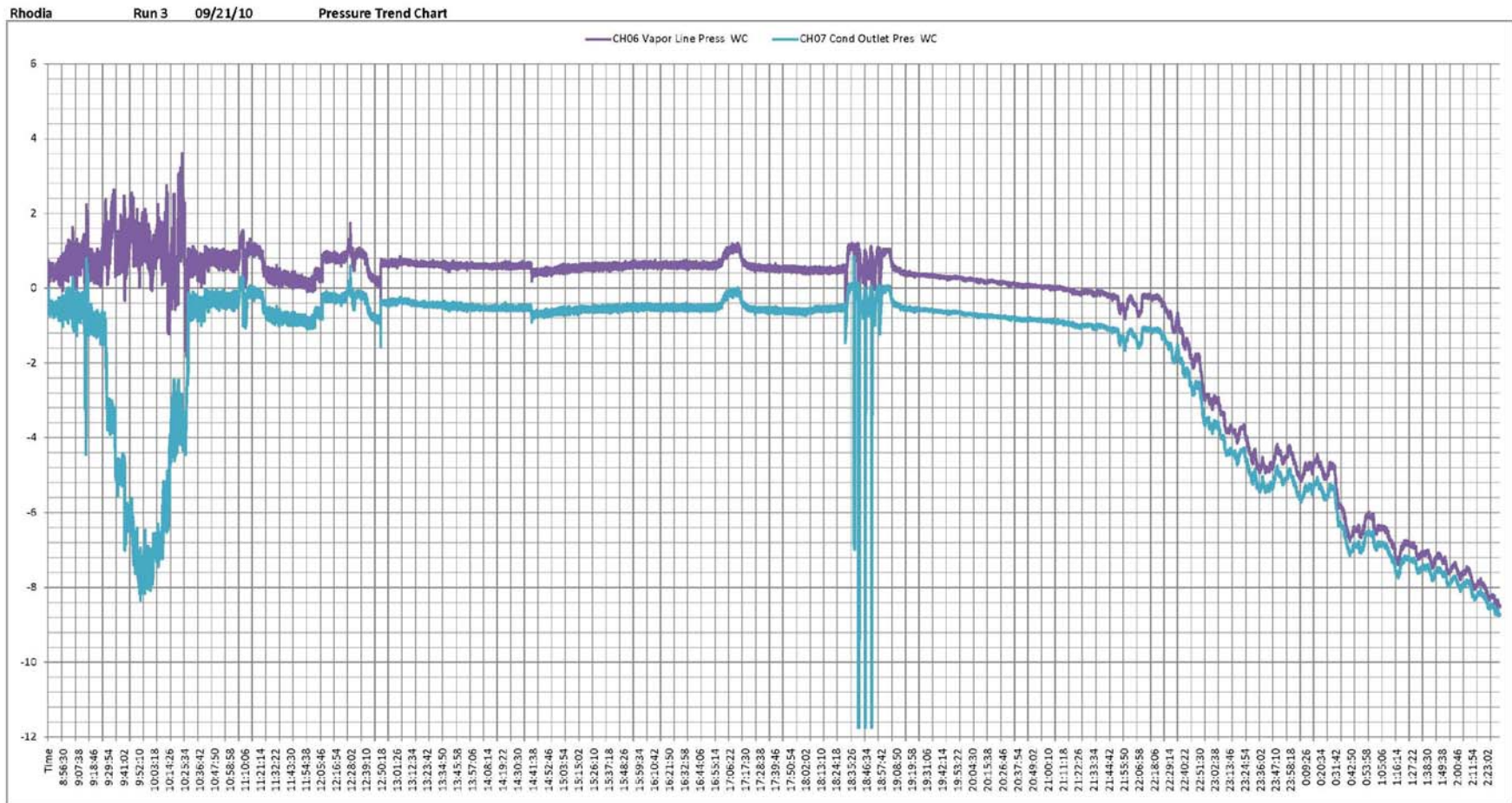

Figure 11 Run #3 Plot of Pressure Data

Rhodia Pilot Phosphorus Recovery System
Batch Summary Data Sheet

Batch No. 03
 Date 9/21/2010 Day Tuesday
 Weather Low 34, high 67, mostly sunny
 Operators Keller, Freeman, Whiteus, Smith

			Miscellaneous Information	
Clarifier Material Sample Location	<u>Clarifier Southside</u>			
Approximate Sample Depth	<u>8' below water</u>			
Batch Start Information				
Pan Still Gross	Pan Still Wt.	Net Batch Wt.		
<u>1525</u>	<u>1183</u>	<u>342</u>		
Batch End Information				
Pan Still Gross	Pan Still Wt.	Net Residue Wt.		
<u>1314</u>	<u>1183</u>	<u>131</u>		
KWH Meter Reading - Start of Batch	<u>258.5</u>			
KWH Meter Reading - End of Batch	<u>401.2</u>			
KWH Consumed for Batch	<u>142.7</u>			
Batch Start Time	<u>8:20 AM</u>		N2 Supply Start	<u>2400+2400</u>
Batch End Time	<u>6:20 PM</u>		N2 Supply End	<u>0 + 0</u>
Batch Run Time	<u>10:00</u>	hours:minutes	N2 Consumed	<u>608 c.f.</u>
Product Container Start Weight	<u>216</u>		TK-100 Start	<u>68</u>
Product Container End Weight	<u>244</u>		TK-100 End	<u>68</u>
Product Produced (Pounds)	<u>28</u>		P4 (Pounds)	<u><1</u>
			% of Batch	
Net Batch Weight (from above)	<u>342</u>		<u>100.00%</u>	
Net Residue Weight (from above)	<u>131</u>		<u>38.30%</u>	
Product Produced - Pounds	<u>28</u>		<u>8.19%</u>	
Net Water Evaporated - Pounds	<u>183</u>		<u>53.51%</u>	

Figure 12 Run #3 Batch Summary Data Sheet

Heat and Material Balance for Run #3

Assumptions and Physical Properties:

1. All of the water was vaporized from the still.
2. The material balance information is from the run #3 operations summary sheet.
3. The total heat consumed for run #3 was 142.7 kWh or 486,912 BTU, from the summary log
4. The water is heated to 202 DegF before vaporization occurs.
5. The phosphorus is heated to 400 DegF before vaporization occurs.
6. The soil/silt that remains in the still is heated to ~600 DegF prior to turning off the furnace.
7. The stainless steel components of the still are heated to an average of ~600 DegF.
8. The initial temperature of the batch is 55 DegF.
9. Calculated weight of the 316SS still is ~456 lbs

Physical properties:

	Heat Capacity (BTU/lb DegF)	Heat of Vap. (BTU/lb)
Soil/Silt	0.2	N/A
Phosphorus	0.184	172
Water	1	970
316 SS	0.12	N/A

Material Balance Summary:

Total Batch Weight	342 lbs
Water	183 lbs
Phosphorus Recovered	28 lbs
Soil/Silt/Phos remaining in still	131 lbs

Heat Required to Recover the Water:

BTU's to heat the water to boiling=	26,901 BTU (7.88 kWh)
BTU's to vaporize the water=	177,510 BTU (52.0 kWh)
Total to process water=	204,411 BTU (59.9 kWh)
% of total process heat=	80%

Heat Required to Recover the Phos.:

BTU's to heat the Phos. to vap. Temp.=	1,777 BTU (0.52 kWh)
BTU's to vaporize the Phos.=	4,816 BTU (1.4 kWh)
Total to process Phos.=	6,593 BTU (1.9 kWh)
% of total process heat=	3%

Heat Required for Still Residue:

Heat Required to heat up the silt/soil=	14,279 BTU (4.18 kWh)
% of total process heat=	6%

Heat Required for Still:

Heat required to heat the 316SS Still=	29,822 BTU (8.74 kWh)
% of total process heat=	12%

Total heat accounted for by the process= 255,106 BTU (74.8 kWh)

Total heat lost through system inefficiencies= 231,806 BTU (67.9 kWh)

Percent heat lost to inefficiencies= 48%

Figure 13 Run #3 Heat Balance

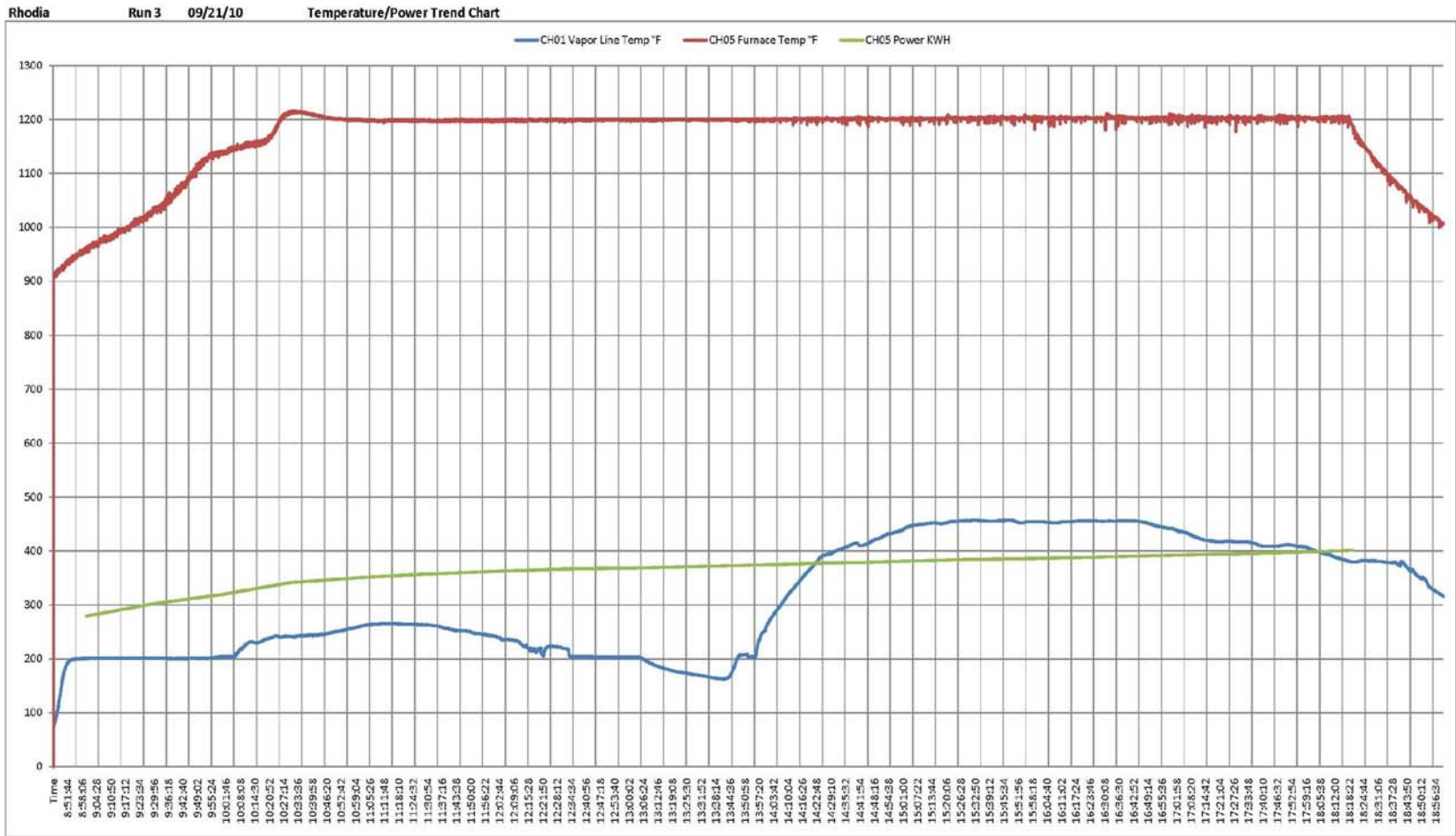

Figure 14 Run #3 Plot of Power-Temperature

7.0 CONCLUSIONS

The basic process as designed demonstrated a capability to safely vaporize and condense the phosphorus contained in the clarifier material. Visually good phosphorus was recovered from all three batches. The non-ignitable residue produced by one batch (run #2) remained hazardous due to leachable cadmium present in the still residue. Additional evaluation is needed to evaluate whether the process can render the crude phosphorus residue to be non-hazardous.

Cycle time for complete vaporization of the phosphorus is reduced by agitation of the still material. A reduction in the cycle time for the still could be made by addressing the fouling that occurs with the muddy cake that deposits on the inside wall of the still. Other improvements in cycle time could be accomplished by reducing the amount of water that is carried in with the feed and minimizing the generation of red phosphorus during a batch. Minimizing the amount of water in the feed might not be possible with the present method of charging the still, but could help significantly in reducing cycle time if accomplished. Minimizing the red phosphorus generation will require finding the optimum set of process conditions, particularly furnace temperature setpoints and ramp rates. An improvement to the furnace which might help in controlling the amount of red phosphorus generated is the addition of a bottom heating coil to the existing furnace. The additional heat transfer area and heat input could assist in reducing the time where the temperature is high enough to convert white phosphorus to red, but not enough to vaporize white phosphorus from the still.

Correct operation of the condenser system requires the temperature to be controlled within a prescribed range. Any future designs should include thermal insulation for piping and equipment to assure systemic heat loss is controllable as part of the design basis and the operational plans.

8.0 FUTURE PLANS

Additional pilot plant runs are tentatively planned for June, July, and August of 2011. A meeting was held January, 2011 in Phoenix, AZ to discuss system modifications, develop a plan for future pilot plant runs, and identify design information that might be needed for the production scale design.

Some recommendations for future improvements to the process include:

8.1 Control Room Improvements

- Install Air Conditioning
- Move Eurotherm furnace temperature controller to control room
- Conduit required for thermocouple (T/C) wires
- Additional #2 welding lead required
- Add Watt-hour meter inputs to data logger
- Control recirculation pump speed with field T/C inputs
- Utilize thermocouple (T/C) input to control water temperatures
- Resolve span issues on water recirculation control I/P air controller

8.2 Furnace and Still Improvements

- Add Thermocouple in Still (agitator) to measure still contents temperature
- Re-design agitator seal (pump style packing) and move blades closer to shell
- Possibly add bottom plate and support to agitator
- Replace faulty sidewall heat coils
- Repair south T/C port (tube not straight)
- Install heat coil in furnace bottom
- Add monorail to install still in furnace
- Add Lifting bale for furnace across lid
- Machine raised face off Still lid flange
- Possibly fabricate spare Still for optimization

8.3 Vapor Line Improvements

- Re-design Vapor Line, possibly larger
- Improve routing, including 45 deg elbows, to reduce trapped phosphorus
- Add additional insulation and heat tracing
- Heat trace block and bleed
- Add chicago couplings for wash lines
- Replace vent line temperature indicator (TI-1000) with lower range gauge
- Replace magnahelic pressure indicator with plus/minus scale gauge

8.4 Nitrogen System Improvements

- Hook up both Nitrogen heaters to input additional heat
- Install temperature controller
- Insulate Nitrogen supply lines
- Consider Liquid N2 supply instead of compressed gas cylinders
- Relocate pressure gauge port

8.5 Condenser Improvements

- Confirm Eductor nozzle size. Possibly install smaller nozzle
- Add control valve for Eductor
- Move VL plug valve to bottom of Condenser
- Add sight glass gaskets
- Weld/replace threaded fittings. Remove unions
- Replace magnahelic pressure indicator with plus/minus scale gauge
- Heat trace and insulate Eductor and Condenser outlet
- Add condenser insulation
- Install heat tape controllers

8.6 Water Recycle System Improvements

- Move fresh water makeup to TK-100 recycle tank
- Install sight glass level indicator on TK-100
- Install visual flow meter
- Re-design overflow collector
- Repair pin hole weld leaks
- Move strainer closer to pump (possible bypass)
- Install heat tape controllers

9.0 PICTURES



Picture of the overall system



Still residue after Run #2



Still residue after Run #3 indicating red phosphorus



Some of the recovered phosphorus immediately after lifting from the water cap.

10.0 PHR RECOMMENDATIONS

RHODIA P4 Recovery Pilot Plant

Process/Procedural Hazard Review

Recommendations

Rec Ref No.	Recommendations	By	Recommendation status
1.1.1.1	Perform practice digging in clarifier, practice runs moving equipment. to ensure no interference when loading material and working around the pilot	KW Completed	Completed test dig(s) in clarifier with CAT mini-excavator. Tested logistics without material in bucket.
1.1.1.2	Include in the procedures for loading the material to take a sample bucket at each level going down, and dump it in the middle of the clarifier to test the consistency of the material to give an indication of what will be dealing with for loading the still.	KW Completed	Completed test dig(s) in the clarifier. Brought up material from multiple depths to judge consistency and material reaction to handling.
1.2.1.1	Will need access to the top of the hopper, so have portable stairway staged to be able to water-wash down top of hopper. Could consider cleaning the hopper in place rather than extending over the clarifier for washing.	KW Completed	Utilizing an eight foot step ladder placed beside the hopper during loading to wash the clarifier material from the sidewalls prior to moving the moving the hopper to the staging area. Water is contained by the Still.
1.3.1.1	In order to keep unauthorized personnel away from potential hazards, consider barricading (cones to identify) ~ 25' (other larger) area- barricaded for safe work area. Need to require proper PPE in the procedures, and may need additional personnel for some policing at the perimeter in the beginning.	KW Completed	An exclusion zone is delineated by cones/candles each time the Still is loaded.
1.3.2.1	Need to design a splash guard for the space between the hopper and the still. Could use a 55 gallon drum, cut in half with a hinge, but will need to seal around the agitator shaft also. One design could consider hangers on the bottom of hopper to attach the splash guard.	KW Completed	Added 8" beams to the containment pan so the top of the Still is raised to a level where the hopper discharge pipe extends down into the Still.
1.3.6.1	Include in procedures--the need to move the still closer to the edge of the containment pan so the operator can decant easier.	KW Completed	Included in the operating procedures
1.3.6.2	Will include in the procedures --to stop decanting the pan still at a level that leaves a small amount of clear water to cover the slurry.	KW Completed	Included in the operating procedures
1.3.7.1	Will need to build ramps to other sampling points and level them out for smooth transport of still.	KW Completed	Fill material was installed and compacted at the east sample site.
1.3.8.1	Could consider installing the lid on the loaded still before moving it back to the pilot to avoid spilling material. However, it might be more difficult logistically to move tools etc. Another possibility is to design a temporary cover for the still to put in place when moving it to avoid spilling.	KW Not Complete. Alternate process utilized	An alternate process is being utilized.
1.3.8.2	Consider installing C-clamp as well as crossed chokers to ensure the still does not slip off the forks of the forklift when moving.	KW Complete	C-clamps are utilized when transporting Still. Crossing the chokers was not necessary.
2.1.1.1	Need to estimate N2 use during a batch to order correct sized bottle and back up bottle, and determine the reorder point.	KW Complete	Quantity consumed is included in the batch summary report.
2.1.1.2	Consider installing some type of shielding around the agitator shaft if the seal fails and P4 is released.	Kw Complete	A open top shield was fabricated that covers the bottom and sides of the agitator packing housing and N2 purge inlet.

36 Figure 15 PHR Recommendations Page 1

RHODIA P4 Recovery Pilot Plant

Process/Procedural Hazard Review

Recommendations

Rec Ref No.	Recommendations	By	Recommendation status
2.1.1.3	Franklin Engineering Group (FEG) will provide the chart for the eductor, as information to be included in the procedures, if the operator has to manually adjust the flow as necessary	FEG Complete	Information has been provided. Process has not been refined enough to have defined adjustments to the eductor system. Adjustments are made to balance the eductor to the vapor line pressure/suction.
2.1.1.4	Need to get the pressure operating parameter set points from Franklin Engineering (FEG) for the still and offtake during normal operation and what max and mins should be.	FEG Complete	Baseline parameters have been provided.
2.2.1.1	Consider modifying the existing extra blind flange on the furnace to be able to vent it safely away from the furnace, or use the nitrogen purge line and branch off of it (since this line would likely be cleared). Be sure the modification design does not interfere with lifting and moving of the lid and furnace. Will need the range for the new pressure gauge on the still, from FEG.	KW Complete	A flanged PRV line with a manual valve has been installed on the 2" nozzle opposite the vapor line. A block and bleed piping spool has also been provide.
2.3.1.1	Determine baseline pressure of the inlet to the eductor to determine if the existing pressure gauge range is correct, or if it should measure a suction.	Rhodia/FEG/ KW Complete	Various operating parameters were experienced during testing, both pressure and suction. The local readout gauge may be replaced with a gauge that reads both positive and negative pressure.
2.3.2.1	Include logging the pressure gauges (PI-1010 & PI-1009 & PI-1011) to record readings and help determine operation of the eductor.	Kw Complete	Pressure indicator gauges are included on the operator log sheet.
2.5.1.1	Will verify that the Recirculation pump could not cause a suction that would overcome the N2 flow.		
2.7.2.1	If there is suspected liquid P4 flowing into the Recirculation tank, would want to drop the discharge line lower (under hot water?) so the P4 doesn't burn on top of the water.	KW Complete	Added a xx tail piece to the bottom drop valve of the TK-100 recycle tank. TK-100 is filled with hot water prior to draining material from the tank.
2.8.1.1	Include in the procedures and determine a way to verify N2 flow to the furnace before ever venting and opening a half baked batch.		
2.9.1.1	Need more information on the rate of heat up for the furnace from the vendor and the estimated temperature calculated for an indication of the batch end time.	Rhodia/FEG/ KW Complete	Testing and analysis, confirmed by data collection will dictate future heat up rates.
2.10.1.1	Install the lid on the pan still before inserting it into the furnace to be able to access the bolts. Install the packing gland last for the agitator.	KW Complete	Included in operating procedures
2.10.1.2	Existing design does not include any pressure indication on the furnace still, need to include this in the design, and determine where to install the pressure instrumentation.	KW Complete	0"-100" w.c. gauge was installed below the PRV outlet.

Figure 15 PHR Recommendations Page 2

RHODIA P4 Recovery Pilot Plant

Process/Procedural Hazard Review

Recommendations

Rec Ref No.	Recommendations	By	Recommendation status
2.10.4.1	Include a level switch in the condenser to minimize the potential of water flowing back into the furnace. Determine the proper action taken by the interlock for the switch- (i.e. stop the water flow to the condenser-either solenoid valve on the fresh water line or interlock temperature control valve, and shut off the pump). Could use the flange for the old overflow to install the level switch if it works with level instrument. Install two level switches with high visual alarm and high high interlocked to close the solenoid valve if reasonable time to respond.	Rhodia/FEG/ KW Complete	High level and High/High level instrumentation has been installed in the condenser. High level switch activates a strobe type indicator light on the second level of the condenser structure and another strobe type indicator light in the control room. High/high level switch activates a warning horn and closes a normally open solenoid valve on the fresh water supply line. High/high level switch also turns off P-100 recirculating pump.
2.11.1.1	Include in the procedures for the spool removal, that the N2 will not be turned off until the spool is removed, and include proper PPE required.	KW In Progress	Procedures for vapor line spool removal are/have been revised several times to reflect the testing conditions. Full P4 gear is required for VL spool removal.
2.13.1.1	FE process engineering to determine the maximum vaporization rate of the P4 compared to condenser capacity to include this type of information in the procedures. Possibly some type of temperature vs. time graph for operators	FEG Complete	Results are difficult to quantify. Preliminary testing has not indicated that it is possible to overload the condenser with P4 vapor. Additional information will be requested from FEG.
2.14.1.1	Devise a cover for over the support of the agitator to be able to avoid build up of P4 when filling the still.	KW Not required	Current procedures require the agitator to be installed after the clarifier material is loaded into the still.
2.14.2.1	Will need to include in procedures for shutdown -- that if the agitator fails during the batch, continue to the end of the batch, and proceed with special procedure for venting before breaking into system.	KW In Progress	To be included in comprehensive revision of the operation procedures to be completed before 2011 pilot testing.
3.3.1.1	FEG process engineering to get high temp set point for temperature control valve for inclusion in procedures.	FEG Complete	Temperature control valve begins to open at 130 degrees F.
3.3.3.1	FEG process engineering to inform of the consequences if the condenser is operated on one spray, so can be included in the operating procedures.	FEG Complete	Condenser was designed to operated on on spray nozzle.
3.3.5.1	Procedures to include the operator to shut off the furnace (maybe at the disconnect) and get to safe ground until cooled down if there is a complete loss of water supply.	KW - In progress	To be included in comprehensive revision of the operating procedures to be completed before 2011 pilot testing.
3.3.6.1	Consider training the operators on how to switch water supply well sources.	KW/Rhodia Complete	Operators were trained.
3.3.6.2	Need additional level of water in the bucket on the vent to the recirculation tank than the level in the recirc tank. However there needs to be an allowance left for condensate to accumulate. Consider 10", but have FEG to confirm. (Note: drum is 18 1/4" tall).	Rhodia/FEG/ KW Complete	Established 10" of water to be maintained in the vent barrel.
3.3.6.3	Include in procedures to check the level in the bucket under the vent for the recirc tank regularly.	KW Complete	Included in the pre-startup checklist
3.6.1.1	Consider how to determine if the heat tracing is working, and include instructions in the procedures.	KW Complete	Visual temperature checks. Included in pre-startup checklist

38 Figure 15 PHR Recommendations Page 3

RHODIA P4 Recovery Pilot Plant

Process/Procedural Hazard Review

Recommendations

Rec Ref No.	Recommendations	By	Recommendation status
3.10.1.1	FEG process engineering to get information about the VFD settings for the pump. Include in the procedures to check the pressure gauges. Could check the pressures for the different scenarios of plugged or lost spray nozzles in the commissioning and baseline testing for inclusion in the procedures.	FEG Complete	VFD settings included in pre-startup checklist. Testing for possible pump speed to pressure control relationships is ongoing.
3.10.3.1	Ensure that the new solenoid valve installed on the water line is a fail closed valve, to not allow water back into the furnace, and consider manual bypass around the solenoid valve also, just in case water needs to be put back into the system once it has cooled down to open the system up safely.	KW Complete	Installed following Process Hazards Review.
3.14.1.1	Include in procedures to check temperature of heaters and record regularly	KW Complete	Included in hourly operator log sheet.
3.15.1.1	Develop a procedure to thaw bottom of condenser in case of material freezing inside.	KW Complete	Utilize Hotsy to super heat recirculation water.
3.15.3.1	Consider hooking up laptop to the datalogger for additional indication of real-time data and trending during runs.	Complete	
3.17.1.1	Need to determine if the Condenser will be flushed to the clarifier for each batch and include in the procedures.	KW/Rhodia Complete	Not required
3.18.1.1	Consider adding N2 sweep line to the head space of the recirculation tank, and include a rotameter or way to confirm flow before having to disassemble the equipment.	KW Complete	Installed following Process Hazards Review.
7.1.1.1	Gather baseline data during commissioning on startup pressures, eductor, etc. for inclusion in the procedures.	Rhodia/FEG/KW Complete	Baseline parameters are included on operator log sheets
7.3.1.1	If there are problems with the strainer always plugging, there is the possibility of increasing the size of the strainer holes, as well as installing a parallel strainer for cleaning.	Not required	No strainer issues were experienced.
8.1.1.1	Since there will be a purge added to the recirc tank with associated flow as needed, be sure that volume of N2 is sufficient.	KW Complete	Two T size N2 tanks (608 c.f.) are provided to ensure a sufficient volume of N2 was available.
12.1.1.1	Check the bolt stretch during heat up of the equipment and consider materials of construction of the bolts compared to the furnace to eliminate leakage from material expansion.	KW Complete	No issues
12.2.2.1	Include to perform pressure check on each individual spray before start up in the procedures.	KW Complete	Included in the pre-startup checklist
12.2.3.1	Perform a check of the solenoid valve by opening the bypass valve around the temperature control valve and verify flow before each batch.	KW Complete	Included in the pre-startup checklist
12.2.4.1	Consider how check the level switch on the condenser somehow between batches, or after the first batch. Later determine the frequency to test the level switches.	Rhodia/FEG/KW Complete	Confirmed operation by installing a blank in the condenser overflow line to fill the condenser to the level required to activate the High/High High level alarms.
12.2.5.1	Consider stroking the temperature control valve in manual from the temperature controller to test its operation before each batch.	KW Complete	Valve operation is checked by lowering the set point on the temperature control instrumentation and verifying in the field.

39 Figure 15 PHR Recommendations Page 4

RHODIA P4 Recovery Pilot Plant

Process/Procedural Hazard Review

Recommendations

Rec Ref No.	Recommendations	By	Recommendation status
12.2.6.1	Include reinstalling the flange guards in the checklist for startup.	KW Complete	Included in procedures
13.1.1.1	Design start up heating ramp rate completed manually for the first batches. The temperature controller can be programmed at different ramp rates after determined pattern. FEG to summarize operating procedures for the controller in automatic and manual for inclusion in procedures.	Rhodia/FEG/ KW Complete	Several ramp rates were utilized to test operating variables.
13.1.1.2	Also include times to try the agitator, initially start it at around approximately 150 degrees and include in the procedures	KW Complete	Agitator rotated freely prior to energizing the furnace.
15.2.1.1	Consider Line-Of-Fire issues around the agitator chain drive, or pinch points and include protection in the design.	KW Complete	A guard was provided around the agitator packing housing.
16.1.1.1	Consider using the exiting drum clamp to help clean out the still.	Not required	
16.1.2.1	Include in the procedures to flush the condenser first by draining the water from the condenser into the drum and overpak-overflowing into the clarifier as the condenser is flushed and then weigh the drum.	KW Complete	Included in the procedures
16.1.3.1	Be sure to check the offtake and flush as needed to prepare for next batch if needed. Need to determine what to flush into or change spool flow direction and run into bucket and include in the procedures.	KW Complete	Block and bleed valving has been provided. A removable spool piece was fabricated to run flush water back to the clarifier.
16.1.4.1	Need to train operators about electrical supply connections to the plant power, to avoid unnecessary power loss.	KW Complete	Operators have been trained on the pilot plant electrical supply system.

Figure 15 PHR Recommendations Page 5

11.0 DRAWINGS

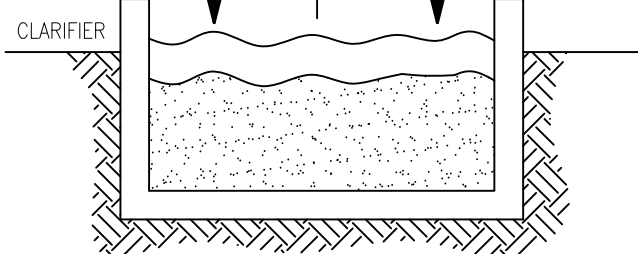
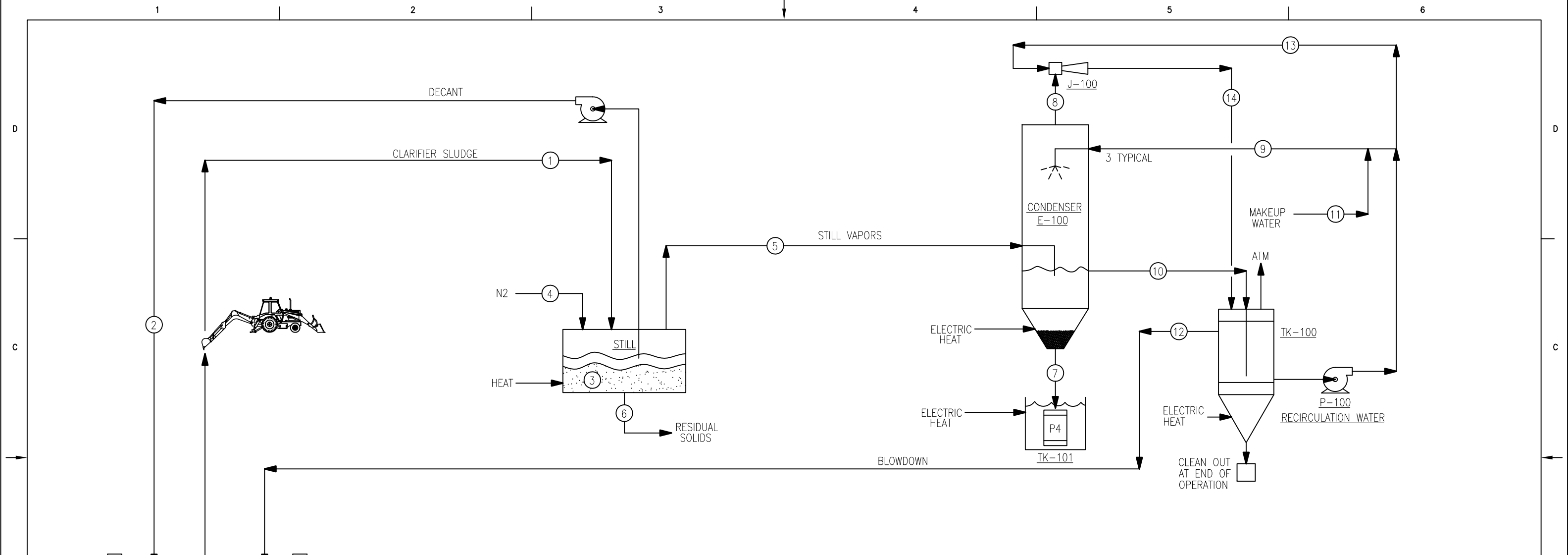

Assumptions

Clarifier P4 content	20.0%	vol%
Clarifier Clear H2O content	22.7%	vol%
Clarifier Sand/silt/h2O content	57.3%	vol%
Solids porosity	25.0%	vol%
Embedded water content	14.3%	vol%
Clarifier Sand/silt content	43.0%	vol%
Clarifier Water content	37.0%	vol%
Clarifier Temp	68	F
Decant vol	46.0%	vol% total H2O
White P --> Red P conversion	24.3%	wt %
White P --> Red P conversion	572	F
White P BP	536	F
Red P Vaporization Temp	731	F
P4 solubility in water	3.33	mg/l
Inert gas sweep rate	2	scfm
Sweep gas temp	68	F
Raw Batch Size	4.10	ft3
Condenser Temp	140	F
HMB Ref Temp	68	F
Atm Pressure	11.95	psia
Technology	Batch Still	
Batch size	3.4	ft3
Max Heat Rate	10	F/min
Max Temp	1400	F

MATERIAL BALANCE (Batch Totals)

PARAMETER	STREAM NUMBER	1	2	3	4	5A	6A	5B	6B	5C	6C	7	8	9	10	11	12	13	14	
	STREAM NAME	From Clarifier	Decant	Still Feed	Sweep Gas	Still Vent	Residue	Still Vent	Residue	Still Vent	Residue	P4	Cond Vent	Spray Water	Cond Overflow	Make-up H2O	Cond B/D	Eductor Water	Eductor Exhaust	
time lapse	min			0	0	57.6	57.6	109.2	109.2	135.4	135.4	135.4	135.4	135.4	135.4	135.4	135.4	135.4	135.4	
temp	F	68	68	68	68	202	202	503	503	731	731	139	140	130	139	68	139	139	139	
temp	C	20.0	20.0	20.0	20.0	94.4	94.4	261.7	261.7	388.3	388.3	59.7	60.0	54.4	59.7	20.0	59.7	59.4	59.4	
temp	K	293.2	293.2	293.2	293.2	367.6	367.6	534.8	534.8	661.5	661.5	332.8	333.2	327.6	332.8	293.2	332.8	332.6	332.6	
pressure	psia			12.45	12.45	12.45	12.45	12.45	12.45	12.45	12.45	11.95	11.95	11.95	11.95	11.95	11.95	11.95	11.95	
Water	lb	94.7	43.6	51.1	0	51.1	0.0	0	0	0	0	0	4.1	8170.0	8217.0	1073.5	1120.6	2877.93	2882.03	
White P	lb	93.1	0.0	93.1	0	1.8	91.3	68.7	0.0	0	0	93.0	0.09	0.024	0.03	0	0.004	0.010	0.10	
Red P	lb	0.0	0.0	0.0	0	0	0	0	22.6	0	0	0	0	0	0	0	0	0	0.00	
Sand/silt	lb	208.7	0.0	208.7	0	0	208.7	0	208.7	0	0	208.7	0	0	0	0	0	0	0.00	
Nitrogen	lb	0.0	0.0	0.0	20.0	8.5	0.0	7.6	0.0	3.9	0	0	0	20.0	0	0	0	0	19.99	
Total	lb	396.5	43.6	352.9	20.0	61.4	300.0	76.3	231.3	26.5	208.7	93.0	24.2	8170.0	8217.1	1073.5	1120.6	2877.9	2902.1	
Water	Pvap psia					12.01	0	0	0	0	0	0	2.89	2.22	2.84	0.34	2.84			
White P	Pvap psia					0.06	0.06	12.00	0	0	0	0.009	0.009	0.007	0.009	0	0.009			
Red P	Pvap psia					0	0	0	0.35	0	0	0	0	0	0	0	0			
Sand/silt	Pvap psia					0	0	0	0	0	0	0	0	0	0	0	0			
Nitrogen	Pvap psia					0.38	0.45	0.45	0.51	0	0	0	9.1	0	0	0	0			
Total	Pvap psia					12.45	12.45	12.45	12.45	0.0	11.95	2.2	2.9	0.3	2.9					
Water	mole-frac					0.965	0.000	0.000	0.242											
White P	mole-frac					0.005	0.964	0.000	0.001											
Red P	mole-frac					0.000	0.000	0.959	0.000											
Sand/silt	mole-frac					0.000	0.000	0.000	0.000											
Nitrogen	mole-frac					0.030	0.036	0.041	0.041											
Total	mole-frac					1.000	1.000	1.000	1.000											
Water	lb-mole	5.26	2.42	2.84	0.00	2.838	0.00	0.00	0.00	0.00	0.00	0.00	0.228	453.49			62.20			
White P4	lb-mole	0.75	0.00	0.75	0.00	0.014	0.55	0.00	0.00	0.75	0.001	0.0002					0.0000			
Red P	lb-mole																			
Sand/silt	lb-mole																			
Nitrogen	lb-mole					0.304		0.272	0.138											
Total	lb-mole					3.156		0.827	0.138											
Total	Actm/gpm					29.568		5.942	0.990					3.545	7.38	7.42	0.95	1.01	2.6	4.00 / 2.60
Water	Btu	0	0	0	0	56.471	0	0	0	0	0	0	133	506.540	586.525	0	79.985			
White P4	Btu	0	0	0	0	360	3,088	16,265	0	0	0	1,221	1.18	0.27	0.36	0	0.05			
Red P	Btu	0	0	0	0	0	0	0	2,015	6,850	0	0	0	0	0	0	0			
Sand/silt	Btu	0	0	0	0	0	5,592	0	20,993	0	0	0	0	0	0	0	0			
Nitrogen	Btu	0	0	0	0	285	0	828	0	641	0	0	360	0	0	0	0			
Total	Btu	0	0	0	0	57.116	8,681	17,093	23,007	7,491	27,670	1,221	494	506,540	586,525	0	79,985			

Physical Properties

	Density	Cp	Latent Heat of Vaporization	Heat of Fusion	MP	BP @ 11.95 psia	MW
	g/cc	Btu/lb°F	BTU/lb	BTU/lb	°F	°F	
Water	1	1	970.3		202	212	18.016
White P	1.82	0.184	172.1	9.16	111.6	503	123.92
Red P	2.2	0.184	172.1			731	
Sand/silt	1.9	0.2					
Nitrogen	0.0738	0.25					28.013
N2 - lb/ft3							
Water Vapor		0.45					18.016

NOTE: BOILING POINTS IGNORE THE EFFECTS OF SWEEP GAS

5		
4		
3		
2		
1	02/25/10	REV. PER 02/24/10 CONF. CALL
0	02/11/10	ISSUED FOR REVIEW
REV.	DATE	REVISION DESCRIPTION

FRANKLIN
engineering group, inc.
DATE: 02-11-10 ALL RIGHTS RESERVED
NOTICE: THIS DRAWING HAS NOT BEEN PUBLISHED AND IS THE SOLE PROPERTY OF FRANKLIN ENGINEERING GROUP. IT IS LOANED TO THE BORROWER FOR THEIR CONFIDENTIAL USE ONLY, AND IN CONSIDERATION OF THE LOAN OF THIS DRAWING, THE BORROWER AGREES TO RETURN IT UPON REQUEST AND AGREES THAT IT SHALL NOT BE REPRODUCED, COPIED, LOANED OR OTHERWISE DISPOSED OF DIRECTLY OR INDIRECTLY NOR USED FOR ANY PURPOSE OTHER THAN FOR WHICH IT IS FURNISHED.

PROJECT MANAGER
LEAD ENG
DESIGNER
CLIENT APPROVAL
SAFETY APPROVAL
Mgmt APPROVAL

FIGURE 1
PILOT PHOSPHORUS
RECOVERY SYSTEM PFD/HMB

RHODIA
BUTTE, MONTANA

SCALE: N.T.S. PAPER: D DRAWING NO: 721-101 SHEET: 1 of 1 REV: 1

1

2

3

4

5

6

H-200
ELECTRIC FURNACE

MFG: THE MELLEEN COMP.
MODEL: CV08-26X30V-1Z
CAP: 45 KW
MAX. TEMP: 1472 °F

E-201
PAN STILL

MFG: FEG
MODEL:
CAP.: 3.5 CU/FT

MX-203
PAN STILL MIXER

HP: 2 HP 3ø 460V

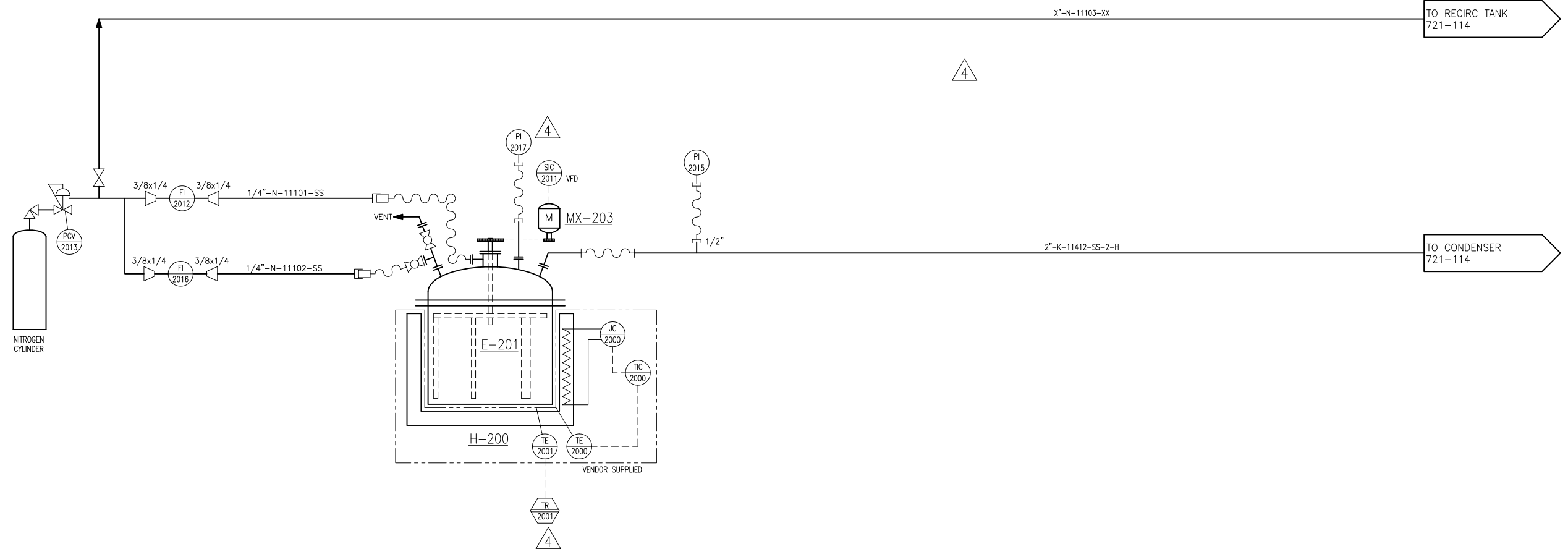

D
C
B
A

D
C
B
A

NOTE:
1, INSTRUMENT TAPS SHALL BE FEMALE NPT UNLESS OTHERWISE NOTED.

5		
4	08/18/10	REVISED PER 08/12/10 HAZARD REVIEW
3	08/04/10	ISSUED FOR HAZARDS REVIEW
2	06/08/10	ADDED INSTRUMENT TAP SIZES
1	06/04/10	REVISED
0	04/29/10	ISSUED FOR BID
REV.	DATE	REVISION DESCRIPTION

FRANKLIN
engineering group, inc.
DATE: 04/29/10 ALL RIGHTS RESERVED
NOTICE: THIS DRAWING HAS NOT BEEN PUBLISHED AND IS THE SOLE PROPERTY OF FRANKLIN ENGINEERING GROUP. IT IS LOANED TO THE BORROWER FOR THEIR CONFIDENTIAL USE ONLY, AND IN CONSIDERATION OF THE LOAN OF THIS DRAWING, THE BORROWER AGREES TO RETURN IT UPON REQUEST AND AGREES THAT IT SHALL NOT BE REPRODUCED, COPIED, LOANED OR OTHERWISE DISPOSED OF DIRECTLY OR INDIRECTLY NOR USED FOR ANY PURPOSE OTHER THAN FOR WHICH IT IS FURNISHED.

PROJECT MANAGER	
LEAD ENG	
DESIGNER	FEG
CLIENT APPROVAL	
SAFETY APPROVAL	
MGMT APPROVAL	
SCALE	NTS
PAPER	D
DRAWING NO.	721-111
SHEET	1 of 1
REV.	4

PILOT PHOSPHORUS RECOVERY SYSTEM
PAN STILL P&ID
RHODIA
BUTTE, MONTANA

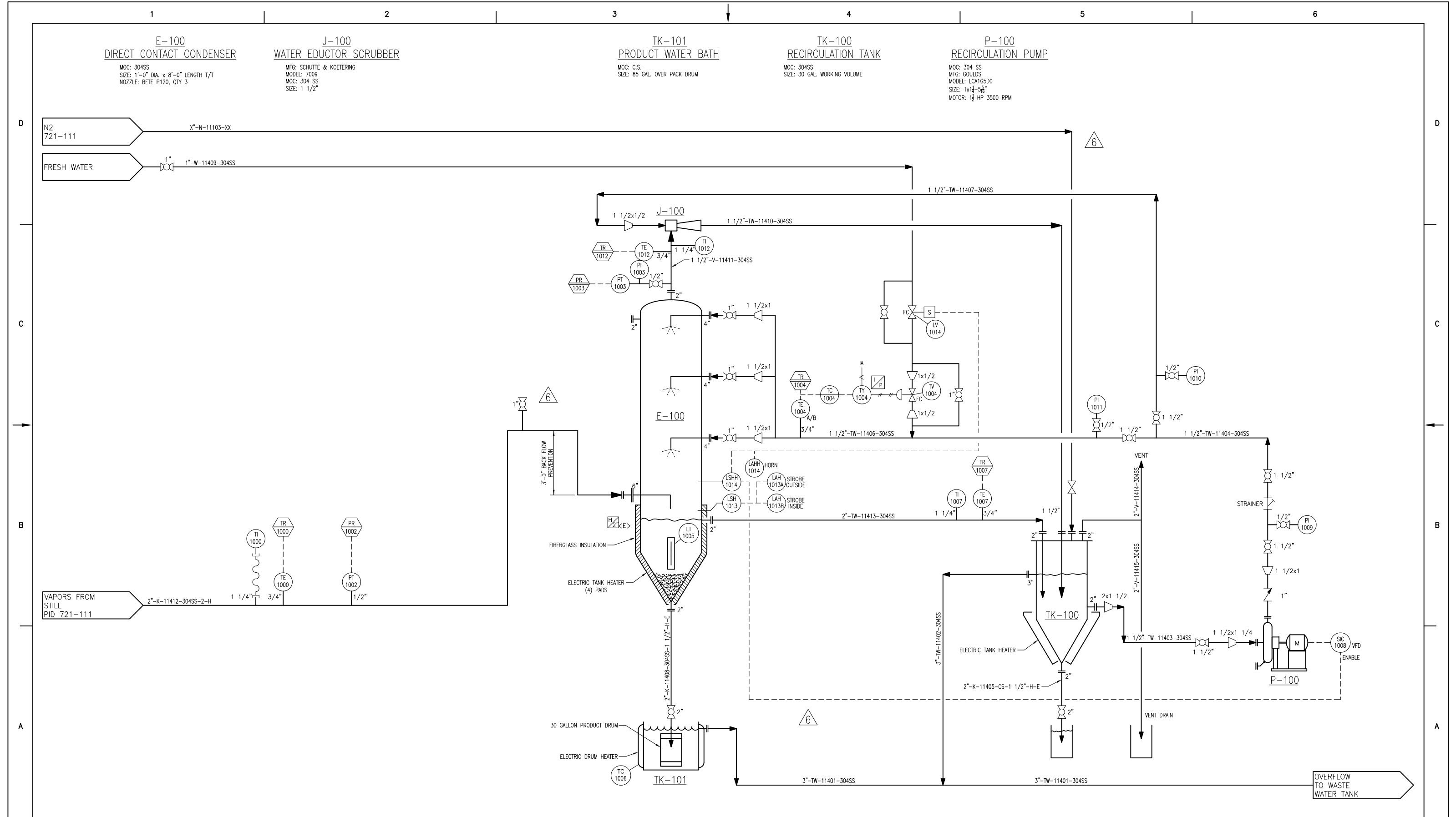

NOTE:
1, INSTRUMENT TAPS SHALL BE FEMALE NPT UNLESS OTHERWISE NOTED.

5	08/04/10	ISSUED FOR HAZARDS REVIEW
4	06/08/10	ADDED INSTRUMENT TAP SIZES
3	06/04/10	REVISED
2	04/29/10	ISSUED FOR BID
1	02/25/10	ISSUED FOR PIPING AND MECH BID
6	08/18/10	REVISED PER 08/12/10 HAZARD REVIEW
REV.	DATE	REVISION DESCRIPTION

FRANKLIN
engineering group, inc.
DATE: 02/11/10 ALL RIGHTS RESERVED
NOTICE: THIS DRAWING HAS NOT BEEN PUBLISHED AND IS THE SOLE PROPERTY OF FRANKLIN ENGINEERING GROUP. IT IS LOANED TO THE BORROWER FOR THEIR CONFIDENTIAL USE ONLY, AND IN CONSIDERATION OF THE LOAN OF THIS DRAWING, THE BORROWER AGREES TO RETURN IT UPON REQUEST AND AGREES THAT IT SHALL NOT BE REPRODUCED, COPIED, LOANED OR OTHERWISE DISPOSED OF DIRECTLY OR INDIRECTLY NOR USED FOR ANY PURPOSE OTHER THAN FOR WHICH IT IS FURNISHED.

PROJECT MANAGER	PILOT PHOSPHORUS RECOVERY SYSTEM CONDENSER P&ID		
LEAD ENG	RHODIA BUTTE, MONTANA		
DESIGNER	RHODIA BUTTE, MONTANA		
CLIENT APPROVAL	SCALE	PAPER	DRAWING NO.
SAFETY APPROVAL	NTS	D	721-114
MGMT APPROVAL	SHEET	1 of 1	
	REV.	6	

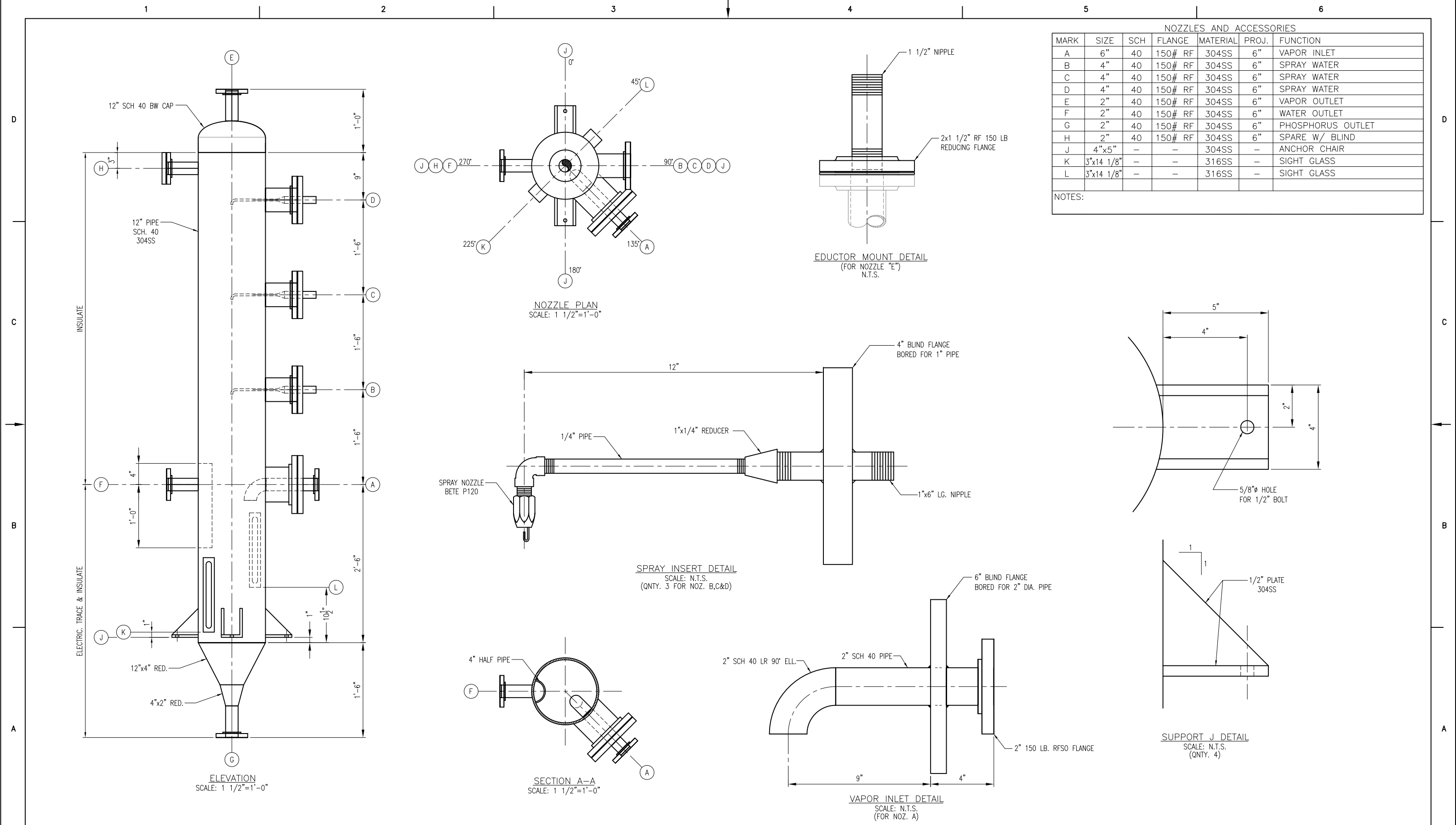

NOZZLES AND ACCESSORIES						
MARK	SIZE	SCH	FLANGE	MATERIAL	PROJ.	FUNCTION
A	6"	40	150# RF	304SS	6"	VAPOR INLET
B	4"	40	150# RF	304SS	6"	SPRAY WATER
C	4"	40	150# RF	304SS	6"	SPRAY WATER
D	4"	40	150# RF	304SS	6"	SPRAY WATER
E	2"	40	150# RF	304SS	6"	VAPOR OUTLET
F	2"	40	150# RF	304SS	6"	WATER OUTLET
G	2"	40	150# RF	304SS	6"	PHOSPHORUS OUTLET
H	2"	40	150# RF	304SS	6"	SPARE W/ BLIND
J	4"x5"	-	-	304SS	-	ANCHOR CHAIR
K	3"x14 1/8"	-	-	316SS	-	SIGHT GLASS
L	3"x14 1/8"	-	-	316SS	-	SIGHT GLASS

NOTES:

NOTE: 1. ALL MATERIALS 304SS UNLESS NOTED.
 2. ALL 304SS THREADED FITTINGS 1 1/2" AND BELOW SHALL BE SCH 80.

REV.	DATE	REVISION DESCRIPTION
5		
4		
3		
2		
1	02/25/10	ISSUED FOR BID
0	02/11/10	ISSUED FOR REVIEW

FRANKLIN
 engineering group, inc.
 DATE: 02/11/10 ALL RIGHTS RESERVED
 NOTICE: THIS DRAWING HAS NOT BEEN PUBLISHED AND IS THE SOLE PROPERTY OF FRANKLIN ENGINEERING GROUP. IT IS LOANED TO THE BORROWER FOR THEIR CONFIDENTIAL USE ONLY, AND IN CONSIDERATION OF THE LOAN OF THIS DRAWING, THE BORROWER AGREES TO RETURN IT UPON REQUEST AND AGREES THAT IT SHALL NOT BE REPRODUCED, COPIED, LOANED OR OTHERWISE DISPOSED OF DIRECTLY OR INDIRECTLY NOR USED FOR ANY PURPOSE OTHER THAN FOR WHICH IT IS FURNISHED.

PROJECT MANAGER	PHOSPHORUS RECOVERY PILOT PLANT CONDENSER E-100 FABRICATION DETAIL
LEAD ENG.	
DESIGNER	
CLIENT APPROVAL	
SAFETY APPROVAL	RHODIA BUTTE, MONTANA
MGMT APPROVAL	
SCALE	1 1/2"=1'-0"
PAPER	D
DRAWING NO.	721-401
SHEET	1 of 1
REV.	1

NOZZLES AND ACCESSORIES						
MARK	SIZE	SCH	FLANGE	MATERIAL	PROJ.	FUNCTION
A	3"	40	150# RF	304SS	6"	OVERFLOW
B	2"	40	150# RF	304SS	6"	PUMP FEED
C	2"	40	150# RF	304SS	6"	DRAIN
D	2"	40	150# RF	304SS	6"	CONDENSER INLET
E	1 1/2"	40	150# RF	304SS	6"	SCRUBBER INLET
F	2"	40	150# RF	304SS	6"	VENT
G	1/2"	-	-	CS	-	EYE BOLT SUPPORT LUG
NOTES:						

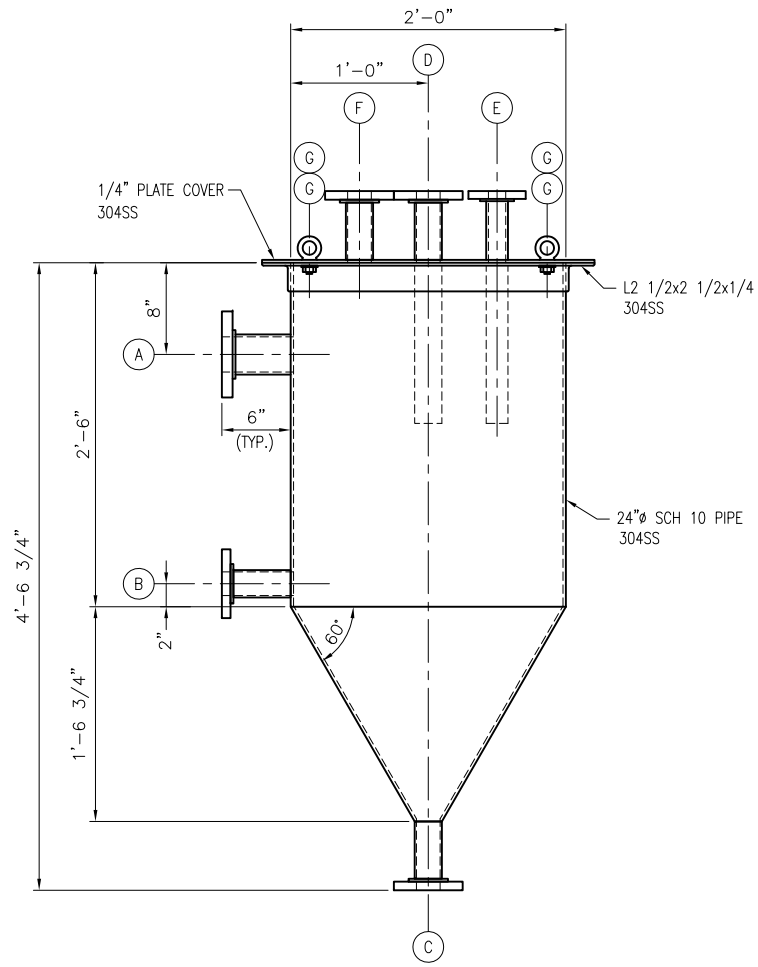

ELEVATION
SCALE: 1 1/2"=1'-0"

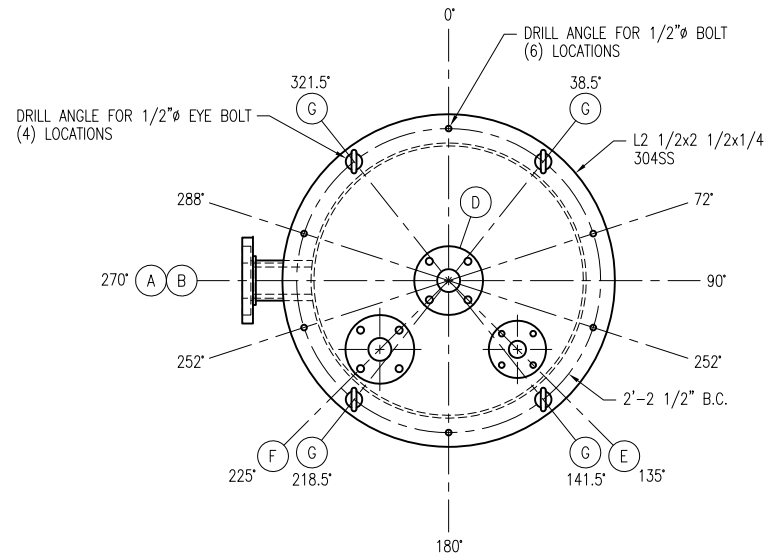

NOZZLE ORIENTATION PLAN
SCALE: 1 1/2"=1'-0"

NOTE: ALL MATERIALS TO BE 304SS UNLESS NOTED

5		
4		
3		
2		
1	02/25/10	ISSUED FOR BID
0	02/11/10	ISSUED FOR REVIEW
REV.	DATE	REVISION DESCRIPTION

© **FRANKLIN**
engineering group, inc.
DATE: 02/11/10 ALL RIGHTS RESERVED
NOTICE: THIS DRAWING HAS NOT BEEN PUBLISHED AND IS THE SOLE PROPERTY OF FRANKLIN ENGINEERING GROUP. IT IS LOANED TO THE BORROWER FOR THEIR CONFIDENTIAL USE ONLY, AND IN CONSIDERATION OF THE LOAN OF THIS DRAWING, THE BORROWER AGREES TO RETURN IT UPON REQUEST AND AGREES THAT IT SHALL NOT BE REPRODUCED, COPIED, LOANED OR OTHERWISE DISPOSED OF DIRECTLY OR INDIRECTLY NOR USED FOR ANY PURPOSE OTHER THAN FOR WHICH IT IS FURNISHED.

PROJECT MANAGER	PHOSPHORUS RECOVERY PILOT PLANT		
LEAD ENG	RECIRCULATION TANK T-100		
DESIGNER	FABRICATION DETAIL		
CLIENT APPROVAL	RHODIA BUTTE, MONTANA		
SAFETY APPROVAL			
MGMT APPROVAL			
SCALE	PAPER	DRAWING NO.	SHEET
1 1/2"=1'-0"	D	721-402	1 of 1

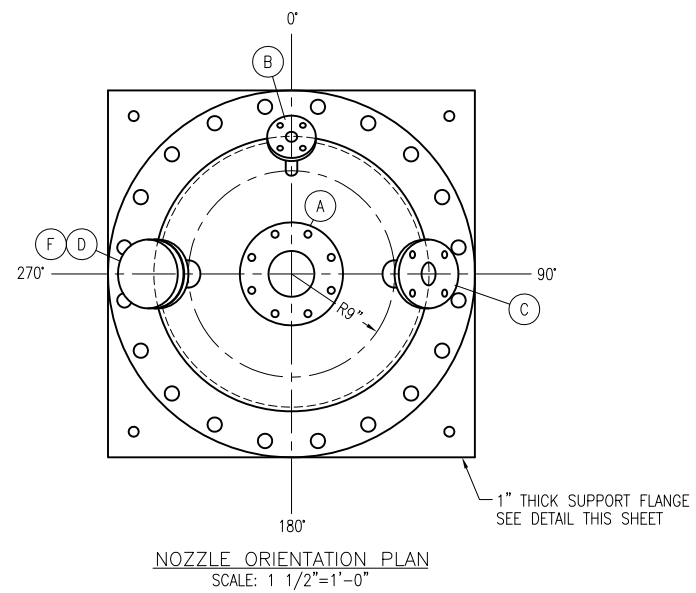

NOZZLE ORIENTATION PLAN
SCALE: 1 1/2"=1'-0"

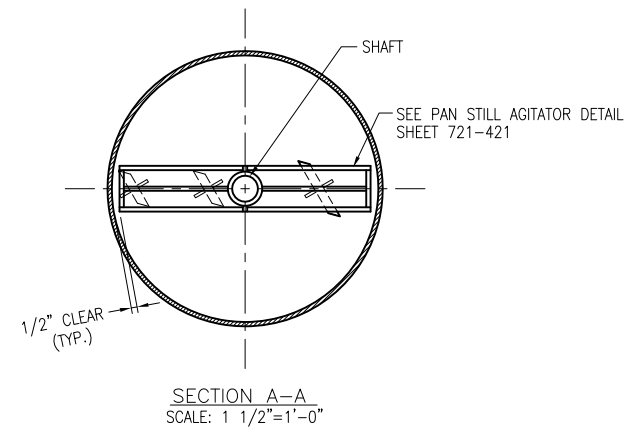

SECTION A-A
SCALE: 1 1/2"=1'-0"

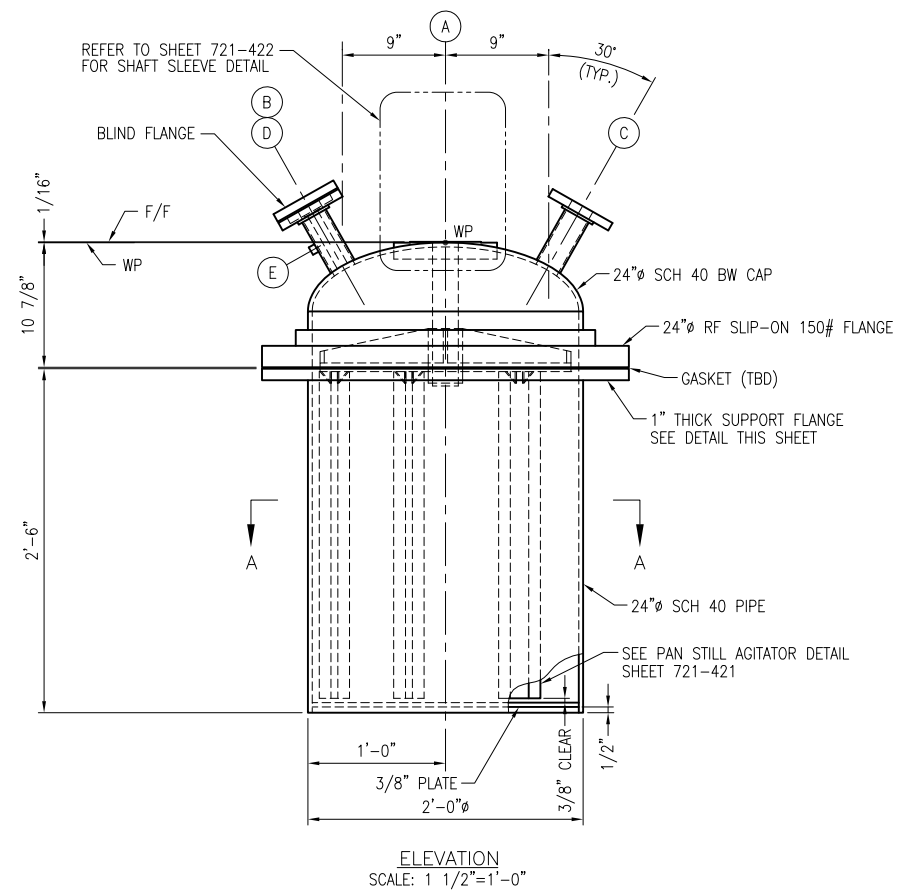

ELEVATION
SCALE: 1 1/2"=1'-0"

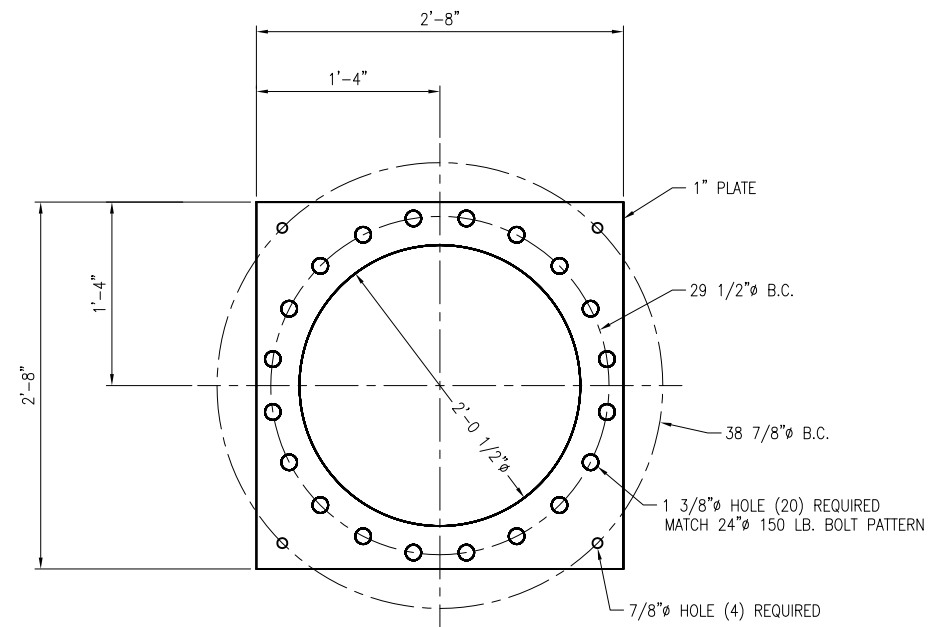

SUPPORT FLANGE DETAIL
SCALE: 1 1/2"=1'-0"

NOZZLES AND ACCESSORIES						
MARK	SIZE	SCH	FLANGE	MATERIAL	PROJ.	FUNCTION
A	4"	-	150# RF	316LSS	-	PAD FLANGE
B	1"	40	150# RF	316LSS	6"	THERMOWELL
C	2"	40	150# RF	316LSS	6"	VAPOR OUTLET
D	2"	40	150# RF	316LSS	6"	BLIND FLANGE
E	1/4" NPT	40	1/2 COUPLING	316LSS	-	NITROGEN

NOTES:

NOTE: ALL MATERIALS TO BE 316L SS UNLESS NOTED

5			FRANKLIN engineering group, inc. DATE: 04/29/10 ALL RIGHTS RESERVED NOTICE: THIS DRAWING HAS NOT BEEN PUBLISHED AND IS THE SOLE PROPERTY OF FRANKLIN ENGINEERING GROUP, IT IS LOANED TO THE BORROWER FOR THEIR CONFIDENTIAL USE ONLY, AND IN CONSIDERATION OF THE LOAN OF THIS DRAWING, THE BORROWER AGREES TO RETURN IT UPON REQUEST AND AGREES THAT IT SHALL NOT BE REPRODUCED, COPIED, LOANED OR OTHERWISE DISPOSED OF DIRECTLY OR INDIRECTLY NOR USED FOR ANY PURPOSE OTHER THAN FOR WHICH IT IS FURNISHED.	PROJECT MANAGER JGD	PHOSPHORUS RECOVERY PILOT PLANT PAN STILL FABRICATION DETAIL
4				LEAD ENG DUL	
3				DESIGNER TRT	
2	06/22/10	REVISED SHAFT SLEEVE DESIGN		CLIENT APPROVAL	
1	05/25/10	ISSUED FOR FABRICATION		DESIGNER 	RHODIA BUTTE, MONTANA
0	04/29/10	ISSUED FOR BID	SAFETY APPROVAL		
REV.	DATE	REVISION DESCRIPTION	MGMT APPROVAL		
				SCALE AS NOTED	PAPER D
				DRAWING NO.	721-420
				SHEET	1 of 1
				REV.	2

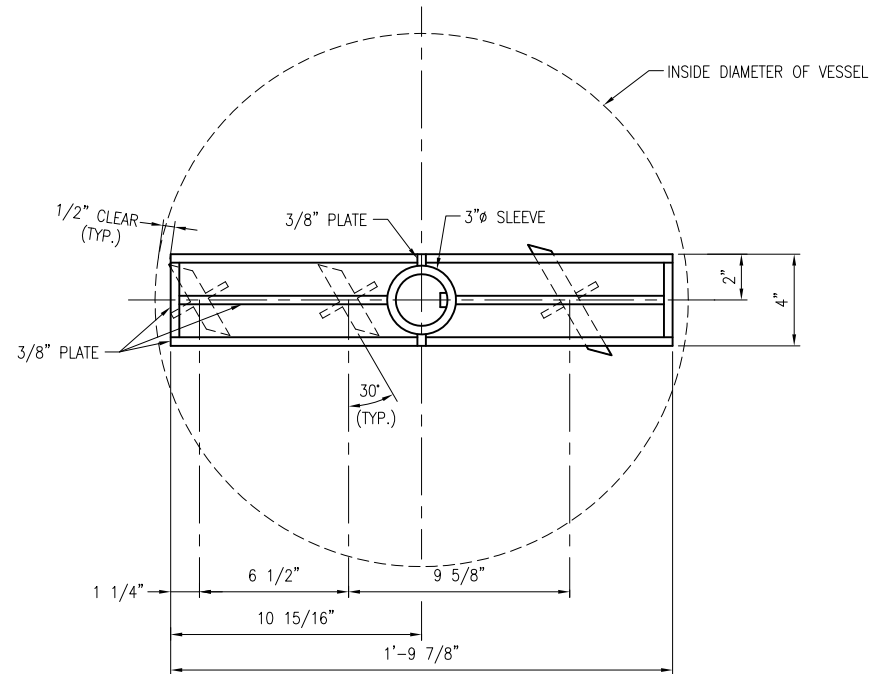

TOP VIEW
SCALE: 3"=1'-0"

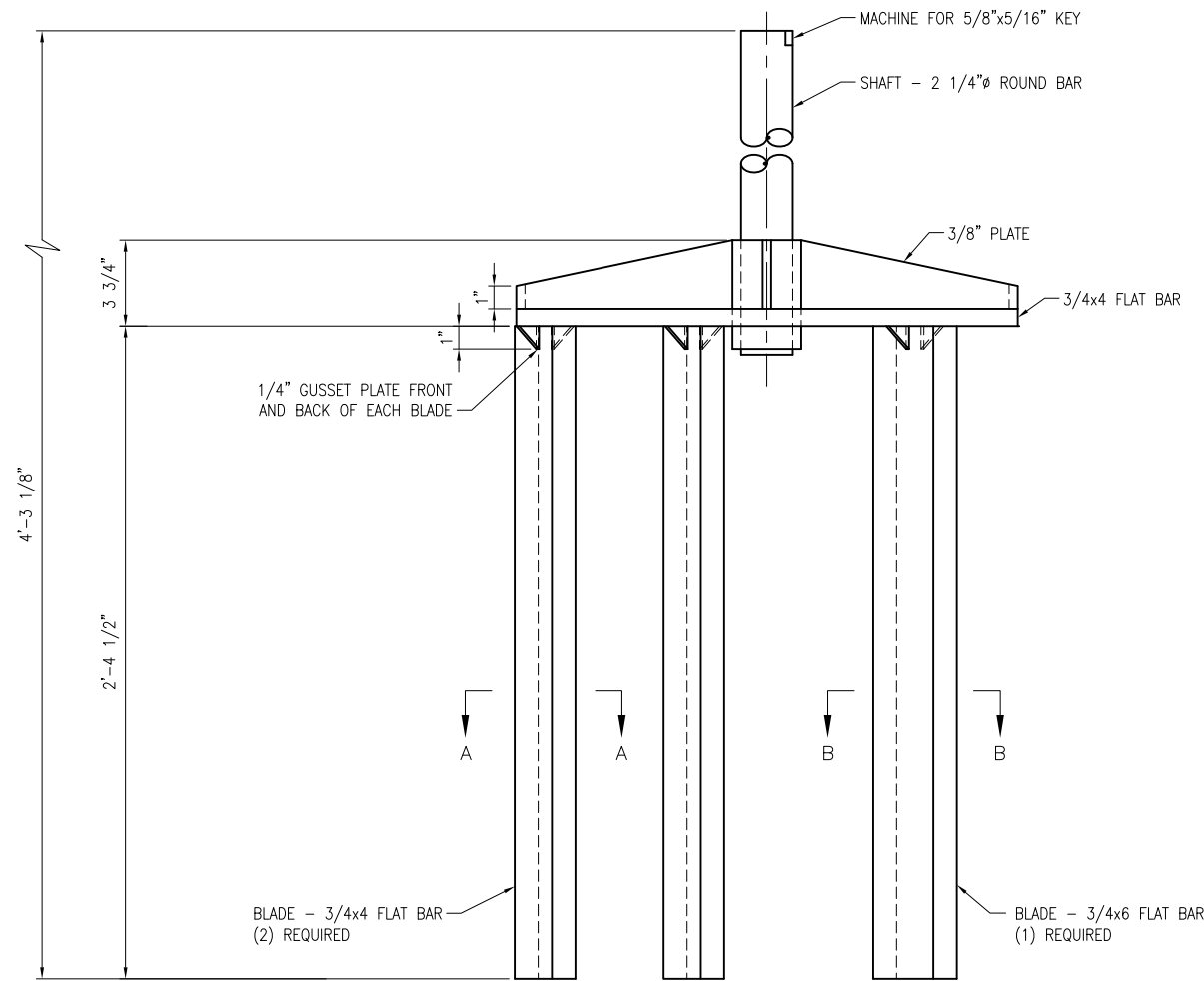

FRONT VIEW
SCALE: 3"=1'-0"

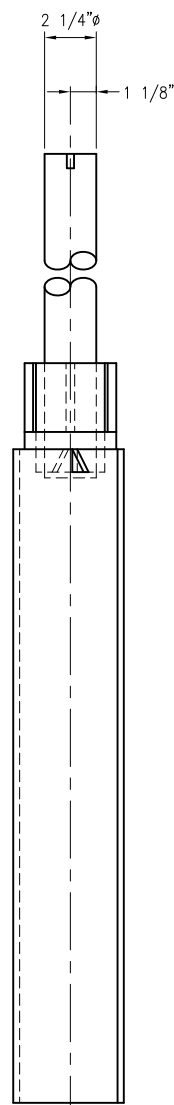

SIDE VIEW
SCALE: 3"=1'-0"

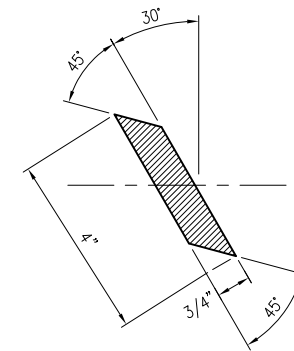

SECTION A-A
SCALE: 6"=1'-0"

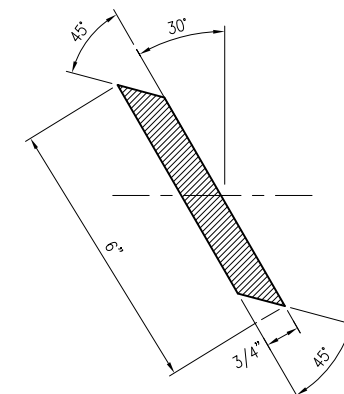

SECTION B-B
SCALE: 6"=1'-0"

NOTE: ALL MATERIALS TO BE 316L SS UNLESS NOTED

REV.	DATE	REVISION DESCRIPTION
5		
4		
3		
2		
1	05/25/10	ISSUED FOR FABRICATION
0	04/29/10	ISSUED FOR BID

© **FRANKLIN**
engineering group, inc.
DATE: 04/29/10 ALL RIGHTS RESERVED
NOTICE: THIS DRAWING HAS NOT BEEN PUBLISHED AND IS THE SOLE PROPERTY OF FRANKLIN ENGINEERING GROUP. IT IS LOANED TO THE BORROWER FOR THEIR CONFIDENTIAL USE ONLY, AND IN CONSIDERATION OF THE LOAN OF THIS DRAWING, THE BORROWER AGREES TO RETURN IT UPON REQUEST AND AGREES THAT IT SHALL NOT BE REPRODUCED, COPIED, LOANED OR OTHERWISE DISPOSED OF DIRECTLY OR INDIRECTLY NOR USED FOR ANY PURPOSE OTHER THAN FOR WHICH IT IS FURNISHED.

PROJECT MANAGER JGD	PHOSPHORUS RECOVERY PILOT PLANT PAN STILL AGITATOR DETAIL
LEAD ENG DUL	
DESIGNER TRT	RHODIA BUTTE, MONTANA
CLIENT APPROVAL	
SAFETY APPROVAL	SCALE AS NOTED
MGMT APPROVAL	PAPER D
	DRAWING NO. 721-421
	SHEET 1 of 1
	REV. 1