

# **MODEL *p*DR-1000AN/1200**

***persona*/DATARAM**

**PARTICULATE MONITOR**

**INSTRUCTION MANUAL**

**P/N (100181-00)**

**THERMO ELECTRON CORPORATION  
ENVIRONMENTAL INSTRUMENTS  
27 FORGE PARKWAY FRANKLIN MASSACHUSETTS 02038**

**(866) 282-0430 Toll Free  
(508) 520-0430 International  
(508) 520-1460 Fax**

**[www.thermo.com/agp](http://www.thermo.com/agp)**

Apr2005

© 2003 Thermo Electron Corporation. All rights reserved. Thermo Electron Corporation, question everything, and Analyze. Detect. Measure. Control are trademarks of Thermo Electron Corporation. All other product names and logos are the property of their respective owner.

Specifications, terms and pricing are subject to change. Not all products are available in all countries. Please consult your local sales representative for details.

# Table of Contents

<b>WARRANTY</b> .....	<b>iv</b>
<b>1.0 GENERAL DESCRIPTION</b> .....	<b>1</b>
<b>2.0 SPECIFICATIONS</b> .....	<b>3</b>
<b>3.0 USER GUIDELINES</b> .....	<b>6</b>
3.1 Handling Instructions.....	6
3.2 Safety Instructions.....	6
3.3 Handling and Operation.....	6
3.3.1 Model <i>pDR-1000AN</i> .....	6
3.3.2 Model <i>pDR-1200</i> .....	7
3.4 Air Sampling Guidelines.....	8
3.5 Environmental Constraints and Certifications.....	8
<b>4.0 ACCESSORIES</b> .....	<b>8</b>
4.1 Standard Accessories.....	8
4.2 Optional Accessories.....	9
<b>5.0 INSTRUMENT LAYOUT</b> .....	<b>9</b>
5.1 Front Panel.....	10
5.2 Bottom Base.....	14
5.3 Right Side Panel.....	14
5.4 Back Panel and Belt Clip.....	17
5.5 Sensing Chamber.....	17
<b>6.0 PREPARATION FOR OPERATION</b> .....	<b>17</b>
6.1 Battery Installation.....	17
6.2 Battery Replacement.....	18
6.3 AC Power Supply.....	18
6.4 Rechargeable Battery Module.....	19
6.5 Zeroing the <i>personal</i> /DataRAM.....	19
6.5.1 Zeroing the model <i>pDR-1000AN</i> .....	19
6.5.2 Zeroing the model <i>pDR-1200</i> .....	20
6.6 <i>pDR-1200</i> Filter Holder Installation.....	21

<b>7.0</b>	<b>OPERATING MODES</b> .....	<b>21</b>
7.1	Start-Up Mode.....	21
7.2	Ready Mode.....	21
7.3	Run and Logging Mode.....	21
	7.3.1 Data Logging.....	22
	7.3.2 Clearing Memory.....	22
	7.3.3 Run Mode Display and Commands.....	22
<b>8.0</b>	<b>OPERATION</b> .....	<b>23</b>
8.1	Start-Up.....	23
8.2	Setting Up For A Run.....	24
8.3	Measurement Run Procedure.....	25
8.4	Abbreviated Run Start/Stop Instructions.....	27
8.5	Resetting Procedure.....	27
<b>9.0</b>	<b>COMMUNICATIONS WITH COMPUTER</b> .....	<b>28</b>
9.1	Hardware and Software Requirements.....	28
9.2	Software Installation Procedure.....	28
9.3	Communications Between <i>personal</i> DataRAM and Computer.....	29
9.4	Real-Time RS-232 Output.....	30
<b>10.0</b>	<b>ANALOG SIGNAL OUTPUT</b> .....	<b>31</b>
10.1	Analog Output Description.....	31
10.2	Analog Output Connection.....	31
<b>11.0</b>	<b>ALARM</b> .....	<b>32</b>
11.1	Alarm Description and Operation.....	32
11.2	Alarm Output.....	32
11.3	Remote Alarm Unit.....	33
<b>12.0</b>	<b>MAINTENANCE</b> .....	<b>33</b>
12.1	General Guidelines.....	33
12.2	Cleaning of Optical Sensing Chamber.....	33
	12.2.1 Model <i>pDR-1000AN</i> .....	33
	12.2.2 Model <i>pDR-1200</i> .....	34
12.3	Cyclone Cleaning (Model <i>pDR-1200</i> only).....	34
<b>13.0</b>	<b>CALIBRATION</b> .....	<b>34</b>
13.1	Factory Calibration.....	34
13.2	Field Gravimetric Calibration.....	35
13.3	Scattering Coefficient Calibration.....	36
13.4	Internal Span Check.....	36

<b>14.0</b>	<b>PARTICLE SIZE CLASSIFICATION (Model <i>pDR-1200</i> only)</b> .....	<b>37</b>
14.1	Size Fractionated Monitoring.....	37
14.2	Particle Sizing.....	37
<b>15.0</b>	<b>CONVERSION BETWEEN <i>personalDataRAM</i> VERSIONS</b> .....	<b>40</b>
15.1	Conversion procedure from <i>pDR-1000AN</i> to <i>pDR-1200</i> .....	40
15.2	Conversion procedure from <i>pDR-1200</i> to <i>pDR-1000AN</i> .....	41
<b>16.0</b>	<b>SEQUENCE OF KEYSTROKES AND SCREENS</b> .....	<b>42</b>
<b>17.0</b>	<b>SERVICE LOCATIONS</b> .....	<b>46</b>

## WARRANTY

Seller warrants that the Products will operate substantially in conformance with Seller's published specifications, when subjected to normal, proper and intended usage by properly trained personnel, for 13 months from date of installation or 12 months from date of shipment, whichever is less (the "Warranty Period"). Seller agrees during the Warranty Period, provided it is promptly notified in writing upon the discovery of any defect and further provided that all costs of returning the defective Products to Seller are pre-paid by Buyer, to repair or replace, at Seller's option, defective Products so as to cause the same to operate in substantial conformance with said specifications. Replacement parts may be new or refurbished, at the election of Seller. All replaced parts shall become the property of Seller. Shipment to Buyer of repaired or replacement Products shall be made in accordance with the provisions of Section 5 above. Lamps, fuses, bulbs and other expendable items are expressly excluded from the warranty under this Section 8. Seller's sole liability with respect to equipment, materials, parts or software furnished to Seller by third party suppliers shall be limited to the assignment by Seller to Buyer of any such third party supplier's warranty, to the extent the same is assignable. In no event shall Seller have any obligation to make repairs, replacements or corrections required, in whole or in part, as the result of (i) normal wear and tear, (ii) accident, disaster or event of force majeure, (iii) misuse, fault or negligence of or by Buyer, (iv) use of the Products in a manner for which they were not designed, (v) causes external to the Products such as, but not limited to, power failure or electrical power surges, (vi) improper storage of the Products or (vii) use of the Products in combination with equipment or software not supplied by Seller. If Seller determines that Products for which Buyer has requested warranty services are not covered by the warranty hereunder, Buyer shall pay or reimburse Seller for all costs of investigating and responding to such request at Seller's then prevailing time and materials rates. If Seller provides repair services or replacement parts that are not covered by the warranty provided in this Section 8, Buyer shall pay Seller therefore at Seller's then prevailing time and materials rates.

ANY INSTALLATION, MAINTENANCE, REPAIR, SERVICE, RELOCATION OR ALTERATION TO OR OF, OR OTHER TAMPERING WITH, THE PRODUCTS PERFORMED BY ANY PERSON OR ENTITY OTHER THAN SELLER WITHOUT SELLER'S PRIOR WRITTEN APPROVAL, OR ANY USE OF REPLACEMENT PARTS NOT SUPPLIED BY SELLER, SHALL IMMEDIATELY VOID AND CANCEL ALL WARRANTIES WITH RESPECT TO THE AFFECTED PRODUCTS.

THE OBLIGATIONS CREATED BY THIS SECTION TO REPAIR OR REPLACE A DEFECTIVE PRODUCT SHALL BE THE SOLE REMEDY OF BUYER IN THE EVENT OF A DEFECTIVE PRODUCT. EXCEPT AS EXPRESSLY PROVIDED IN THIS SECTION 8, SELLER DISCLAIMS ALL WARRANTIES, WHETHER EXPRESS OR IMPLIED, ORAL OR WRITTEN, WITH RESPECT TO THE PRODUCTS, INCLUDING WITHOUT LIMITATION ALL IMPLIED WARRANTIES OF MERCHANTABILITY OR FITNESS FOR ANY PARTICULAR PURPOSE. SELLER DOES NOT WARRANT THAT THE PRODUCTS ARE ERROR-FREE OR WILL ACCOMPLISH ANY PARTICULAR RESULT.

## 1.0 GENERAL DESCRIPTION

The Thermo Electron Corporation *personalDataRAM*<sup>TM</sup> (for *Personal Data*-logging *Real-time Aerosol Monitor*) is a technologically advanced instrument designed to measure the concentration of airborne particulate matter (liquid or solid), providing direct and continuous readout as well as electronic recording of the information.

The *personalDataRAM* is available in two versions: model *pDR-1000AN* and model *pDR-1200*. The model *pDR-1000AN* operates as a passive air sampler whereas the model *pDR-1200* uses active air sampling. The user can convert from one to the other of these two versions by means of optional conversion kits offered by Thermo Electron (see Sections 4.2 and 15.0 of this manual).

The model *pDR-1000AN* passively samples (i.e., without a pump) the air surrounding the monitor; air freely accesses the sensing chamber of the instrument by means of convection, diffusion, and adventitious air motion. The model *pDR-1200*, on the other hand, requires a separate vacuum pump (not included) such as Thermo Electron's *pDR-PU*, a personal-type pump for its operation.

In addition, the model *pDR-1200* includes a particle size-selective inlet cyclone which permits size segregated measurements (i.e., PM<sub>10</sub>, PM<sub>2.5</sub>, respirable, etc.) as well as enabling the user to perform aerodynamic particle sizing by varying the sampling flow rate. The model *pDR-1200* incorporates, downstream of its photometric sensing stage, a standard 37-mm filter holder on which all sampled particles are collected for subsequent analysis or gravimetric referencing/calibration, if so desired.

The *personalDataRAM* is the result of many years of field experience acquired with thousands of units of its well known predecessor, the Thermo Electron/MIE MINIRAM, and embodies many technological advances made possible by the latest electronic hardware and software. The *personalDataRAM* is also a worthy miniaturized companion to the Thermo Electron DataRAM 4, a recognized paragon of portable aerosol monitors.

The *personalDataRAM* is a high sensitivity nephelometric (i.e. photometric) monitor whose light scattering sensing configuration has been optimized for the measurement of the respirable fraction of airborne dust, smoke, fumes and mists in industrial and other indoor environments.

The *personalDataRAM* is an ultra-compact, rugged and totally self-contained instrument designed for hand-held, belt-worn, as well as unattended operation. It is powered either by its internal replaceable 9V battery, or by an optional attachable rechargeable battery pack, or by an AC supply (included as standard accessory). For the model *pDR-1200*, power to an adjunct pump must be provided separately.

Zeroing is accomplished by means of a hand-inflatable “zero air” pouch included with the model *pDR-1000AN*, and by an inlet filter cartridge provided with the model *pDR-1200*. In addition, the instrument automatically checks agreement with its original factory calibration by checking its optical background during the zeroing sequence.

The *personalDataRAM* covers a wide measurement range: from 0.001 mg/m<sup>3</sup> (1 µg/m<sup>3</sup>) to 400 mg/m<sup>3</sup>, a 400,000-fold span, corresponding to very clean air up to extremely high particle levels.

In addition to the auto-ranging real-time concentration readout, the *personalDataRAM* offers the user a wide range of information by scrolling its two-line LCD screen, such as run start time and date, time averaged concentration, elapsed run time, maximum and STEL values with times of occurrence, etc.

Operating parameters selected and diagnostic information displays are also available. Furthermore, the *personalDataRAM* features complete, large capacity internal data logging capabilities with retrieval through an externally connected computer. The stored information (up to 13,000 data points) includes average concentration values, maximum and STEL values with time information as well as tag numbers.

Selectable alarm levels with built-in audible signal and switched output, a RS-232 communications port, and a programmable analog concentration output (voltage and current) are all part of this versatile instrument.

A custom software package is provided with the *personalDataRAM* to program operating/logging parameters (e.g. logging period, alarm level, concentration display averaging time, etc.) as well as to download stored or real-time data to a PC or laptop for tabular and/or graphic presentation. If required, the data can also be imported to standard spreadsheet packages (e.g. Microsoft Excel™, IBM Lotus 1-2-3™, etc.).



## 2.0 SPECIFICATIONS

- Concentration measurement range (auto-ranging)<sup>1</sup>: 0.001 to 400 mg/m<sup>3</sup>
- Scattering coefficient range: 1.5 x 10<sup>-6</sup> to 0.6 m<sup>-1</sup> (approx.) @ λ =880 nm
- Precision/repeatability over 30 days (2-sigma)<sup>2</sup>:  
± 2% of reading or ±0.005 mg/m<sup>3</sup>, whichever is larger, for 1-sec. averaging time  
±0.5% of reading or ±0.0015 mg/m<sup>3</sup>, whichever is larger, for 10-sec. averaging time  
±0.2% of reading or ±0.0005 mg/m<sup>3</sup>, whichever is larger, for 60-sec. averaging time
- Accuracy<sup>1</sup>: ±5% of reading ±precision
- Resolution: 0.1% of reading or 0.001 mg/m<sup>3</sup>, whichever is larger
- Particle size range of maximum response: 0.1 to 10 μm
- Flow rate range (model pDR-1200 only): 1 to 10 liters/minute (external pump required)
- Aerodynamic particle sizing range (model pDR-1200 only): 1.0 to 10 μm
- Concentration display updating interval: 1 second
- Concentration display averaging time<sup>3</sup>: 1 to 60 seconds
- Alarm level adjustment range<sup>3</sup>: selectable over entire measurement range
- Alarm averaging time<sup>3</sup>: real-time (1 to 60 seconds), or STEL (15 minutes)
- Datalogging averaging periods<sup>3</sup>: 1 second to 4 hours
- Total number of data points that can be logged in memory: 13,391
- Number of data tags (data sets): 99 (maximum)
- Logged data:
  - ❖ Each data point: average concentration, time/date, and data point number
  - ❖ Run summary: overall average and maximum concentrations, time/date of maximum, total number of logged points, start time/date, total elapsed time (run duration), STEL concentration and time/date of occurrence, averaging (logging) period, calibration factor, and tag number.

- Elapsed time range: 0 to 100 hours (resets to 0 after 100 hours)
- Time keeping and data retention: > 10 years
- Readout display: LCD 16 characters (4 mm height) x 2 lines
- Serial interface: RS-232, 4,800 baud
- Computer requirements: IBM-PC compatible, 486, Pentium, or higher, Windows™ '95 or higher, ≥ 8 MB memory, hard disk drive, CD-ROM Drive, VGA or higher resolution monitor
- Outputs:
  - ❖ Real-time digital signal (1 sec<sup>-1</sup>): concentration, 16-character code, simplex mode
  - ❖ Real-time analog signal: 0 to 5 V and 4 to 20 mA. Selectable full scale ranges: 0-0.1, 0-0.4, 0-1.0, 0-4.0, 0-10, 0-40, 0-100, and 0-400 mg/m<sup>3</sup>.
  - ❖ Minimum load impedance for voltage output: 200 kΩ.
  - ❖ Maximum load impedance for current output: 300 Ω (when powered by AC power supply)
  - ❖ Alarm output: 1 Hz square wave, 5 V peak-to-peak amplitude. Load impedance > 100 kΩ
- Internal battery: 9V alkaline, 20-hour run time (typical)
- Current consumption: 15 to 25 mA (in Run Mode); 10 to 20 mA (in Ready Mode)
- AC source: universal voltage adapter (included) 100-250 V~, 50-60 Hz (CE marked)
- Optional battery pack: model *pDR-BP*, rechargeable NiMH, 72-hour run time (typical)
- Operating environment: -10° to 50° C (14° to 122° F), 10 to 95% RH, non-condensing
- Storage environment: -20° to 70° C (-4° to 158° F)
- Dimensions (max. external):
  - ❖ Model *pDR-1000AN*: 153 mm (6.0 in) H x 92 mm (3.6 in) W x 63 mm (2.5 in) D
  - ❖ Model *pDR-1200* (including cyclone and filter holder): 160 mm (6.3 in) H x 205 mm (8.1 in) W x 60 mm (2.4 in) D

- Weight:
  - ❖ Model *pDR-1000AN*: 0.5 kg (18 oz)
  - ❖ Model *pDR-1200*: 0.68 kg (24 oz)
- Cyclone (included in model *pDR-1200* only): Model KTL
- Filter holder (included in model *pDR-1200* only): Model MAWP037AO (with 0.8  $\mu\text{m}$  pore size filter)

---

<sup>1</sup> Referred to gravimetric calibration with SAE Fine (ISO Fine) test dust (mmd = 2 to 3  $\mu\text{m}$ ,  $\sigma_g = 2.5$ , as aerosolized)

<sup>2</sup> At constant temperature and full battery voltage

<sup>3</sup> User selectable

---

## 3.0 USER GUIDELINES

### 3.1 Handling Instructions

The *personalDataRAM* is a sophisticated optical/electronic instrument and should be handled accordingly. Although the *personalDataRAM* is very rugged, it should not be subjected to excessive shock, vibration, temperature or humidity. As a practical guideline, the *personalDataRAM* should be handled with the same care as a portable CD player.

If the *personalDataRAM* has been exposed to low temperatures (e.g. in the trunk of a car during winter) for more than a few minutes, care should be taken to allow the instrument to return near room temperature before operating it indoors. This is advisable because water vapor may condense on the interior surfaces of the *personalDataRAM* causing temporary malfunction or erroneous readings. Once the instrument warms up to near room temperature, such condensation will have evaporated. If the *personalDataRAM* becomes wet (e.g. due to exposure to water sprays, rain, etc.), allow the unit to dry thoroughly before operating.

Whenever the *personalDataRAM* is shipped care should be taken in placing it in its carrying case and repackaging it with the original cardboard box with the factory provided padding.

### 3.2 Safety Instructions

- Read and understand all instructions in this manual.
- Do not attempt to disassemble the instrument. If maintenance is required, return unit to the factory for qualified service.
- The *personalDataRAM* should be operated only from the type of power sources described in this manual.
- When replacing the internal 9V battery, follow the instructions provided on the back panel of the unit.
- Shut off *personalDataRAM* and any external devices (e.g. PC or Laptop) before connecting or disconnecting them.
- Shut off *personalDataRAM* before replacing the internal battery, or when plugging in or disconnecting the AC power supply or the optional rechargeable battery pack.

### 3.3 Handling and Operation

#### 3.3.1 Model *pDR-1000AN*

The model *pDR-1000AN* can be operated in any position or orientation. Exposure to high intensity fluctuating light of the interior of the sensing chamber, through the front and back slotted air openings (see Section 5.5), should be avoided. Such large intensity transients may cause erroneous readings. Direct access of sunlight to the sensing chamber should be prevented.

Typical modes of instrument support/handling include:

- Hand-held. Do not obstruct or cover the sensing chamber opening slots on front and back of unit.
- Belt attached. Use belt clip provided as standard accessory. The unit can be worn on a waist belt, or with optional shoulder belt (model *pDR-SS*) for breathing zone monitoring.
- Tabletop operation. The *pDR-1000AN* can be placed on a table either in an upright position (i.e., resting on its lower protective bumper), or on its back (i.e., resting on the rear edges of its two protective bumpers).
- Tripod mounted. The unit can be attached to any standard tripod using the threaded bushing on the bottom of the monitor (see Figure 3).
- Fixed point operation. The model *pDR-1000AN* can be mounted at a fixed location (e.g., wall or post) using the optional wall-mounting bracket, model *pDR-WB*.

### 3.3.2 Model *pDR-1200*

The *pDR-1200* requires an external vacuum pump, such as a small diaphragm pump (e.g., model *pDR-PU*) for its sampling operation. The inlet of the pump must be connected by means of tubing to the hose fitting on the *pDR-1200* 37-mm filter holder attached to sensing chamber (see Figure 2).

The inlet metal tube of the cyclone can be oriented in any desired direction (i.e., upward, forward, downward or backward) by rotating the cyclone body within its holder cup on the right side of the sensing chamber (see Figure 2).

Always ensure unobstructed access to the cyclone inlet when sampling directly the air in the instrument's vicinity. Alternatively, tubing can be connected to the cyclone inlet in order to extract a sample stream from a duct, chamber or other enclosed volume.

Typical modes of instrument support/handling include:

- Hand-held. For example, using a personal type pump, clipped to the belt and using a tubing connection to the *pDR-1200*.
- Belt attached. Use belt clip kit provided as standard accessory. The unit can be worn on a waist belt, or with the optional shoulder belt (model *pDR-SS*) for breathing zone monitoring. A personal pump can then be belt-worn as well.
- Tabletop operation. The *pDR-1200* can be placed on a table either in an upright position (i.e. resting on its lower protective bumper), or on its back (i.e. resting on its backside).
- Wall mounted for fixed point monitoring. Use optional wall mounting bracket, model *pDR-WB*, either in combination with model *pDR-PU* pump module and model *pDR-AC* power supply (powering both the *pDR-1200* and the *pDR-PU*), or with a separate pump.

- Tripod mounted. The unit can be attached to any standard tripod using the threaded opening on the bottom base (see accessory attachment fitting on Fig. 4).

### **3.4 Air Sampling Guidelines**

Although the *personalDataRAM* is designed primarily for intramural use, i.e. for indoor air quality, in-plant, or mining environment monitoring, its active sampling version (model *pDR-1200*) also makes it compatible with extramural use (i.e. ambient monitoring). General ambient monitoring applications, however, are performed preferentially using an appropriate inlet configuration, in order to ensure representative particle sampling under conditions of variable wind speed and direction. Consult with Thermo Electron Corporation for such outdoor applications.

For typical area monitoring applications, the *personalDataRAM* should be placed and operated centrally within the area to be monitored, away from localized air currents due to fans, blowers, ventilation intakes/exhausts, etc. This is to ensure representative sampling within the area to be assessed.

### **3.5 Environmental Constraints and Certifications**

The *personalDataRAM* is designed to be reasonably dust and splash resistant, however, it is not weatherproof. To operate the unit outdoors provisions should be made to protect it from environmental extremes outside its specified range, and from any exposure to precipitation.

The *personalDataRAM* has received intrinsic safety approval (No. 2G-4126-0) from the U.S. Mine Safety and Health Administration (MSHA) for use in coal-mining environments containing methane gas. The MSHA approval (type 2G) closely resembles the standard intrinsic safety rating as defined by Class 1, Div. 1, Group D. This approval makes the MIE *personalDataRAM* the only commercially produced direct reading dust monitor so certified by MSHA and, therefore, the only instrument of this type permitted to be used routinely in U.S. coal mines and similar environments.

The *personalDataRAM* is certified for compliance with the electromagnetic radiation limits for a Class A digital device, pursuant to part 15 of the FCC Rules. The unit also complies and is marked with the CE (European Community) approval for both immunity to electromagnetic radiation and absence of excessive emission interference.

## **4.0 ACCESSORIES**

### **4.1 Standard Accessories**

The *personalDataRAM* is provided to the user with the following standard accessories:

- Soft-shell carrying case (Thermo Electron model *pDR-CC-1*)
- Digital communications cable (Thermo Electron model *pDR-DCC*)
- Analog signal/alarm output cable (Thermo Electron model *pDR-ANC*)
- Communications software disk (Thermo Electron model *pDR-COM*)
- Z-Pouch zeroing kit (Thermo Electron model *pDR-ZP* [for use with *pDR-1000AN* only])
- Zeroing filter cartridge and tubing (Thermo Electron model *pDR-ZF*)(for use with *pDR-1200* only)
- Belt clip kit (Thermo Electron model *pDR-CA*)
- AC power supply (and charger for optional Thermo Electron model *pDR-BP*) (Thermo Electron model *pDR-AC*)
- Metal cyclone (Thermo Electron model *pDR-GK2.05*)(for use with *pDR-1200* only)
- 37-mm filter holder and hose fitting (Thermo Electron model *pDR-FH*)(for use with *pDR-1200* only)
- Instruction manual

## 4.2 Optional Accessories

The following optional accessories are available from Thermo Electron for use with the *personalDataRAM*:

- Rechargeable battery module (Thermo Electron model *pDR-BP*)
- Shoulder strap (Thermo Electron model *pDR-SS*)
- Remote alarm unit (Thermo Electron model *pDR-RA*)
- Wall mounting bracket (Thermo Electron model *pDR-WB*)
- Active sampling kit to convert model *pDR-1000AN* to model *pDR-1200* (Thermo Electron model *pDR-ASC*)
- Upper bumper kit to convert model *pDR-1200* to model *pDR-1000AN* (Thermo Electron model *pDR-UB*)
- Attachable pump unit (Thermo Electron model *pDR-PU*)(for use with *pDR-1200* only)

## 5.0 INSTRUMENT LAYOUT

The user should become familiar with the location and function of all externally accessible controls, connectors and other features of the *personalDataRAM*. Refer to Figures 1 through 6.

All user related functions are externally accessible. All repair and maintenance should be performed by qualified Thermo Electron personnel. Please contact the factory if any problem should arise. Do not attempt to disassemble the *personalDataRAM*, except as described in Section 12.0 (Maintenance), **otherwise voiding of instrument warranty will result.**

## 5.1 Front Panel

Refer to Figures 1 (for model *pDR-1000AN*) or 2 (for model *pDR-1200*) for location of controls and display.

The front panel contains the four touch switches (keys) and the LCD screen required for the operation of the *personalDataRAM*.

The four touch switches provide tactile ("popping") feedback when properly actuated.

The ON/OFF key serves only to turn on the unit (while it is in the off state), and to turn it off (when it is operating).

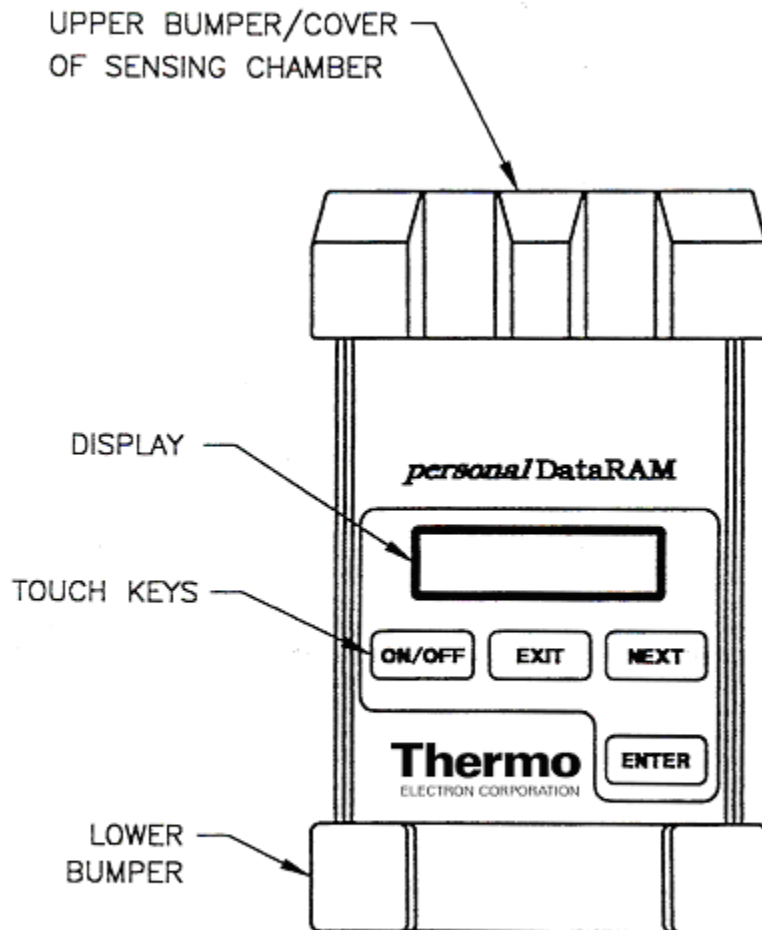

Figure 1 – FRONT PANEL (MODEL *pDR-1000AN*)



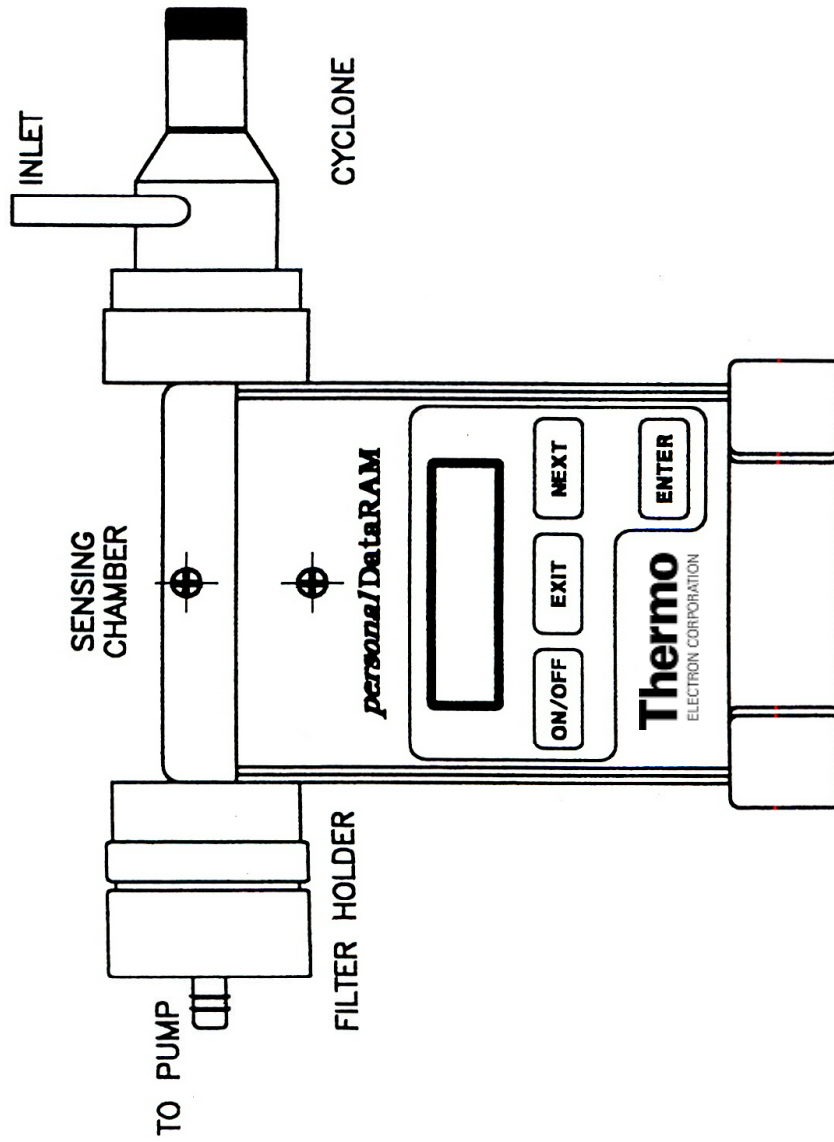

Figure 2. MODEL pDR-1200 WITH CYCLONE & 37MM FILTER HOLDER

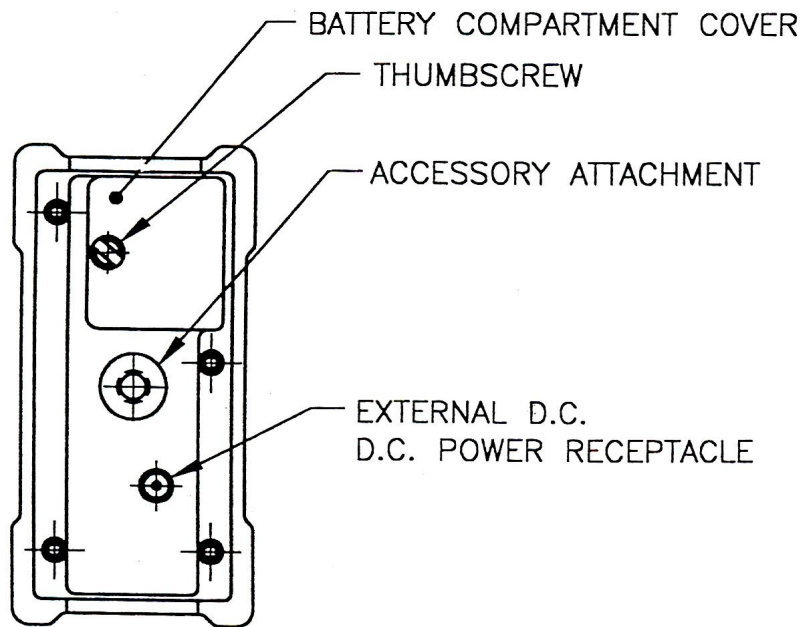

Figure 3 - BOTTOM BASE (MODEL pDR-1000AN)

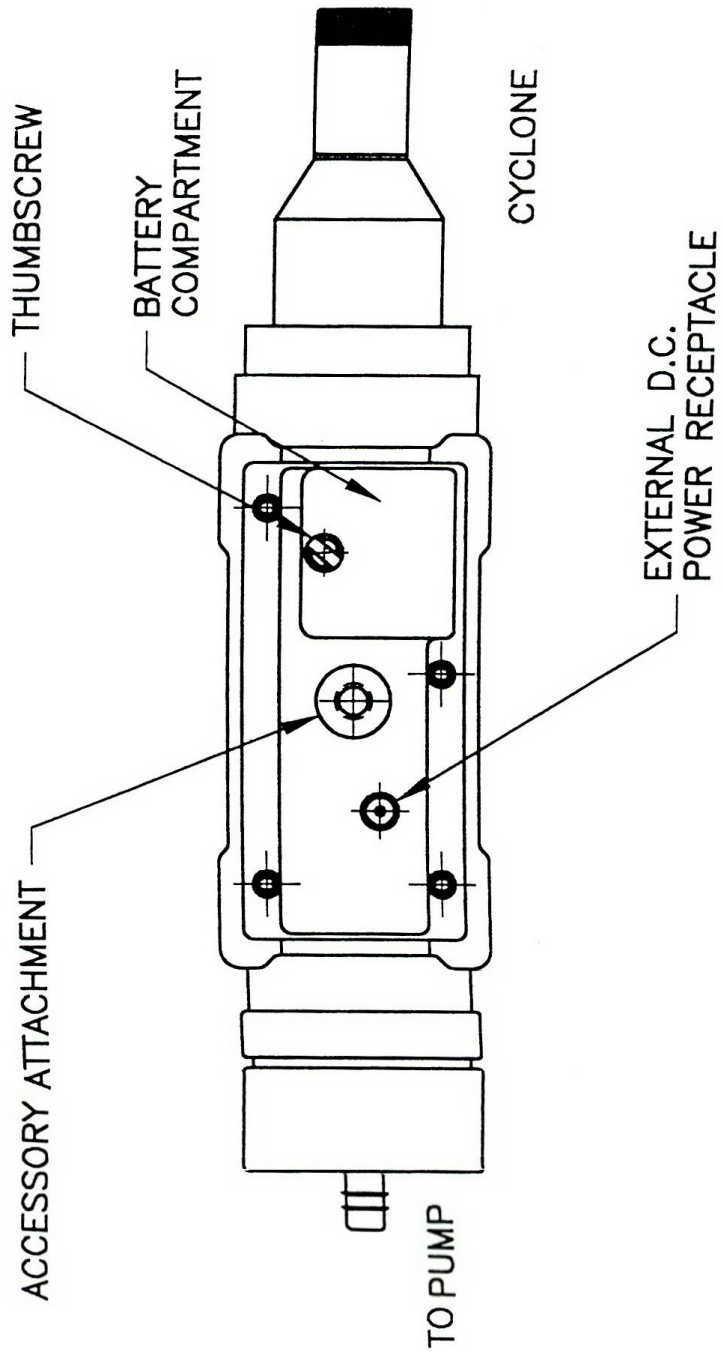

Figure 4 - BOTTOM VIEW (MODEL pDR-1200)

The EXIT and ENTER keys serve to execute specific commands that may be indicated on the screen, and the NEXT key generally serves to scroll the displayed information, e.g. to review the operating parameters that have been programmed, display maximum/STEL values, diagnostic values, etc.

If an incorrect command is keyed (e.g. ENTER when the *personalDataRAM* displays real-time concentration) a beep is heard to alert the user.

The two-line, 16-character per line LCD indicates either measured values of concentration (instantaneous and time averaged on the same screen), elapsed run time, maximum and STEL (short term excursion limit) values, operating and logging parameters, diagnostics, or other messages.

The acoustic alarm transducer is located directly behind the center of the Thermo Electron Corporation logo on the front panel.

## **5.2 Bottom Base**

Refer to Figures 3 (for model *pDR-1000AN*) or 4 (for model *pDR-1200*). The base of the *personalDataRAM* contains the following: a) internal battery compartment cover, b) external DC power input receptacle, and c) threaded bushing for the attachment of optional battery pack, tripod, or other mounting/support hardware.

Only the internal battery compartment cover should be opened by the user, for removal and replacement of the on-board 9V battery. Removal of the base plate could result in voiding of instrument warranty.

## **5.3 Right Side Panel**

Refer to Figures 5 (for model *pDR-1000AN*) or 6 (for model *pDR-1200*) which shows the manner of attachment of the belt clip assembly (belt clip should be attached only if required by the user). The right side panel (as viewed from front panel) contains the RJ-12 6-contact modular jack connector receptacle for digital (RS-232) communications and analog signal output. This connector also provides the alarm output control for a remote/auxiliary alarm signal. The contacts (from top to bottom) are:

- 1: 4 – 20 mA analog output (positive)
- 2: Alarm output
- 3: Digital data transmission
- 4: Digital input
- 5: Common ground (signal returns)
- 6: 0 to 5 V analog output (positive)

The digital communications cable provided as a standard accessory is to be inserted into this receptacle for interconnection to a computer (for data downloading or to

reprogram parameters). The analog output cable is provided with flying leads for interconnection with other data processing and/or control systems.

**WARNING:** The modular jack receptacle on the side of the *personalDataRAM* should be used only for communications with computers and alarm circuitry. **Do not, under any circumstance, connect any communications equipment (e.g., telephone) to this receptacle.**

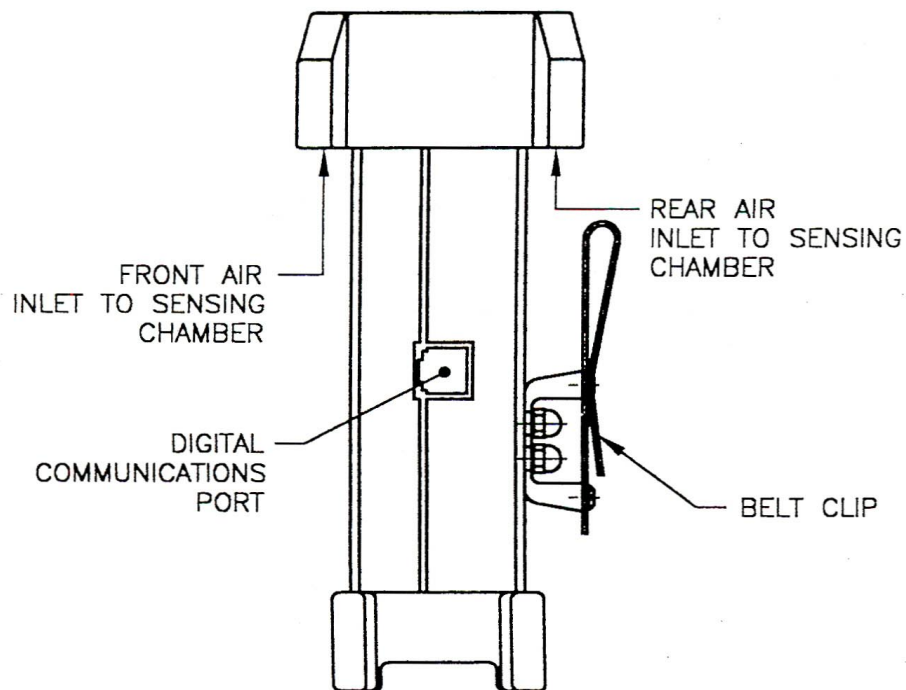

Figure 5 — RIGHT SIDE PANEL (MODEL pDR-1000AN)  
(SHOWN WITH BELT CLIP ATTACHED)

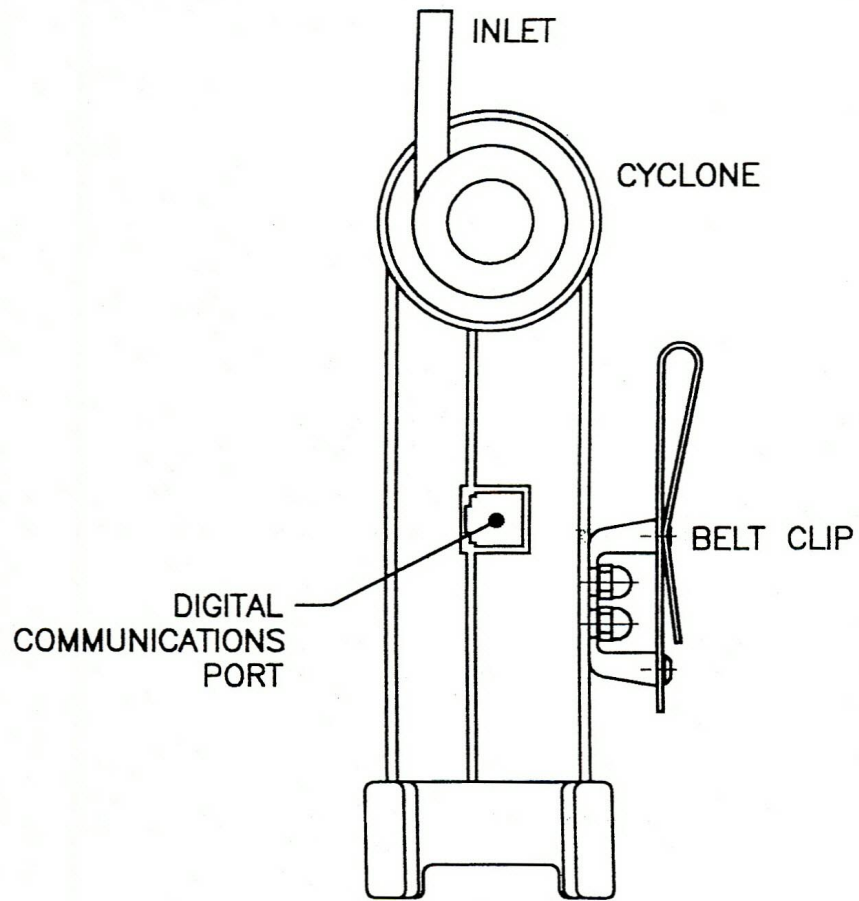

Figure 6 – RIGHT SIDE VIEW (MODEL pDR-1200)  
(SHOWN WITH BELT CLIP ATTACHED)

## 5.4 Back Panel and Belt Clip

The back panel consists of a label with important user information on safety procedures and certifications, model and serial numbers, etc. and is provided with mounting hardware for the attachment of the belt clip kit (see Figures 5 or 6 for mounting configuration of the belt clip).

## 5.5 Sensing Chamber

Referring to Figure 1 or 2, the upper mid-section of the *personalDataRAM* contains the optical sensing chamber. This chamber is the only internal section that the user should access for maintenance purposes (see Section 12.2).

On the model *pDR-1000AN*, air enters the sensing chamber through the two slot shaped inlets (one on the front and other on the back) under the protective bumper. During instrument operation those two openings should remain unobstructed in order to ensure free access of the surrounding air. When the model *pDR-1000AN* is used as personal monitor, i.e., clipped to a person's belt, the rear air inlet opening may be partially obstructed, but care should be exercised in ensuring that the front air inlet remains free of any obstructions.

On the model *pDR-1200*, air enters the sensing chamber through the opening in the cyclone receptacle cup (black cup on right side of sensing chamber), passes through the photometric stage, and exits through the opening in the filter holder receptacle cup (black cup on left side of sensing chamber), after which the air passes through the filter.

## 6.0 PREPARATION FOR OPERATION

### 6.1 Battery Installation

When shipped from the factory, the *personalDataRAM* will arrive without its replaceable 9V battery installed. Two fresh alkaline batteries (Duracell® type MN1604) are factory packed separately in the carrying case, one of which should be installed in the *personalDataRAM* when preparing it for operation.

NOTE: Whenever the *personalDataRAM* is to be left unused for an extended time (i.e. longer than a month), the 9V battery should be removed from the unit.

Removing the battery will lose neither the program, time/date keeping, nor stored data.

To install the battery proceed as follows:

- Hold the *personalDataRAM* upside down.
- Loosen thumbscrew that secures the battery compartment cover (see Figure 3 or 4), and remove that cover.

- Observe battery polarity and the back panel battery orientation pattern (the negative battery terminal is the one closer to the side of the instrument).
- Insert the battery by sliding it in until it bottoms out. It should protrude slightly above the bottom surface of the instrument.
- Place battery compartment cover over battery and, while pushing down the cover firmly (taking care that the cover seats flush on the bottom surface of the *personalDataRAM*), tighten thumbscrew securely.

## 6.2 Battery Replacement

Normally, only a 9V Duracell® type MN1604 alkaline batteries should be used with the *personalDataRAM* in accordance the MSHA intrinsic safety approval.

Only fresh batteries should be used in order to ensure the maximum operating time. The *personalDataRAM* shuts itself off whenever the battery voltage falls below 6 volts (while retaining all programming and data). A fresh 9V alkaline battery, at room temperature, should provide typically 20 hours of continuous operation (please note that not all manufacturers produce batteries of equal capacity). Intermittent operation should extend the total running time because of partial battery recovery effects.

The approximate remaining battery capacity is indicated by the *personalDataRAM* (see Section 8.2) in increments of 1%, starting from 99%. If the remaining battery capacity is 40% or less, immediate restarting after shut off is automatically inhibited to prevent incomplete runs. If, nevertheless, a new run is to be initiated with low remaining battery capacity, do not shut off the *personalDataRAM* at the end of the previous run (i.e., remain in the Ready Mode, see section 7.0).

When significantly extended operating times are required (beyond the typical 20 hours), the use of either lithium or zinc-air batteries can be considered. The use of such alternative battery types can provide about 2 to 3 times longer operation than alkaline batteries.

## 6.3 AC Power Supply

A universal line voltage AC to DC power supply (Thermo Electron model *pDR-AC*) is provided as standard accessory with the *personalDataRAM*. This power supply can be used with any line with a voltage between 100 and 240 VAC (50 to 60 Hz). When using that power supply, its output plug should be inserted into the external DC receptacle at the base of the *personalDataRAM* (see Figure 3 or 4). Insertion of that connector automatically disables the internal 9V battery of the instrument. Removal of the *pDR-AC* plug from the instrument automatically re-connects the internal 9V battery.

**NOTE: Before plugging in or unplugging the external power supply, the *personalDataRAM* must be shut off.**



## 6.4 Rechargeable Battery Module

A rechargeable battery pack (Thermo Electron model *pDR-BP*) is available as an optional accessory. This unit attaches directly to the base of the *personalDataRAM*.

The *pDR-BP* contains a sealed nickel-metal-hydride battery (NiMH), which provides typically 72 hours of continuous operation between successive charges (for 3-hour charging).

The use of the *personalDataRAM*, in combination with the *pDR-BP* connected to the AC power line ensures totally uninterrupted operation over an indefinite period. In this operating mode, line power interruptions lasting up to 72 hours have no effect on measurement run continuity.

To attach the *pDR-BP* to the *personalDataRAM*, the instrument should be shut off. Carefully plug the *pDR-BP* into the external DC receptacle on the *personalDataRAM*. Rotate the large thumbscrew at the opposite end of the *pDR-BP* tightening it firmly. The *pDR-BP* can be recharged by means of the AC power supply of the *personalDataRAM*.

Detailed instructions for the use of the rechargeable battery module are furnished with that accessory.

## 6.5 Zeroing the *personalDataRAM*

One of the most important steps to be performed by the user before initiating a measurement run with the *personalDataRAM* is to zero the instrument. This is required to ensure maximum accuracy of concentration measurements, especially at low levels, i.e. below about  $0.1 \text{ mg/m}^3$ .

During the 2-minute pre-run automatic zeroing sequence (see Section 8.1), the *personalDataRAM* registers its own optical background, stores that level in its memory, and then subtracts that background from all measured concentration values, until the zero is updated again by the user.

Although zeroing can be performed as often as desired (e.g., before every run), in practice it should not be necessary to do so more than once-a-month or even less frequently, except if average particulate concentrations should exceed about  $0.5 \text{ mg/m}^3$ .

### 6.5.1 Zeroing the model *pDR-1000AN*

Zeroing of the model *pDR-1000AN* requires a particle-free environment such as a clean room, clean bench, duct or area directly downstream of a HEPA filter, or the *pDR-1000AN Z-Pouch* (standard accessory). In some cases, a very clean, well air-conditioned office may offer a sufficiently low particle concentration environment

(i.e.,  $\leq 5 \mu\text{g}/\text{m}^3$ ) for zeroing, as determined by another monitor (e.g., Thermo Electron DataRAM 4).

To zero the model *pDR-1000AN* by means of its Z-Pouch, proceed as follows:

- Wipe the outside surfaces of the *pDR-1000AN* to remove as much dust from those surfaces as possible before placing the instrument inside the Z-Pouch.
- In a reasonably clean environment, open the zipper of the Z-Pouch and place the *pDR-1000AN* inside it. Close the zipper shut.
- Open the small nipple on the Z-Pouch, and insert the fitting of the hand pump/in-line filter unit into the nipple.
- Start pumping the hand-pump until the Z-Pouch begins to bulge, and proceed with the steps in Section 8.1, pressing the keys of the instrument through the wall of the Z-Pouch. Then slowly continue to pump to maintain positive pressure within the Z-Pouch.
- After completing the zeroing (step 2. of Section 8.1) procedure, open the Z-Pouch zipper and remove the *pDR-1000AN*. Close the zipper and flatten the Z-Pouch while plugging its nipple, in order to prevent dust contamination of the interior of the Z-Pouch.
- The *pDR-1000AN* is now zeroed and ready for a measurement run.

### 6.5.2 Zeroing the model *pDR-1200*

To provide the particle-free air required to zero the *pDR-1200*, either of two methods can be used: a) place the instrument on a clean-air bench or in a clean room, or b) connect to the cyclone inlet the green zeroing filter cartridge supplied with the *pDR-1200*. In either case, proceed as follows:

- After implementing either of the two methods, above, run the attached pump for at least one minute (e.g., at 2 liters/minute), and then proceed as described in Section 8.1 of this instruction manual, while continuing to run the pump (or leaving the unit in the clean air environment).
- Once the CALIBRATION: OK message appears on the *pDR-1200* display, stop the pump and disconnect the zeroing filter cartridge from the cyclone inlet (or remove *pDR-1200* from clean bench/room).
- The *pDR-1200* is now zeroed and ready for a measurement run.

**Note:** While the *pDR-1200* is used to monitor high dust concentrations ( $\geq 0.5 \text{ mg}/\text{m}^3$ ), the flow through its sensing chamber should not be stopped before purging it, which can be done by connecting the green zeroing filter to the cyclone inlet and continuing to run the pump for about 2 minutes before shutting it off. This is to prevent dust contamination of the sensing chamber.

## 6.6 *p*DR-1200 Filter Holder Installation

The 37-mm filter holder provided with the *p*DR-1200 must be installed before operation of the instrument, in order to connect a sampling pump. To install the filter holder, remove protective cover, and insert the open collar over the black attachment cup with the external o-ring, on the left side of the *p*DR-1200 sensing chamber. Ensure complete insertion.

To replace the membrane filter separate the two sections of the plastic holder prying them apart with screwdriver or a coin. Make sure to place backing under the membrane filter before rejoining the two plastic rings.

## 7.0 OPERATING MODES

The *personal*DataRAM has several different operating modes which will be described in what follows. The specific commands and displays within each of these operating modes will be explained in detail in Section 8.0. A complete flow chart of keystrokes and screens is provided in Section 16.0.

### 7.1 Start-Up Mode

The *personal*DataRAM enters the Start-Up Mode as soon as the instrument is switched on. The user then has the choice to:

- a) Wait before proceeding;
- b) Zero the instrument and check its readiness; or
- c) Proceed directly to the Ready Mode.

### 7.2 Ready Mode

Once the *personal*DataRAM is in the Ready Mode, the user is presented with the following alternatives:

- a) Start a run immediately, or after any of the subsequent steps;
- b) Review (by scrolling the display) all operating parameters, status and diagnostic data;
- c) Activate or deactivate the logging function; activate, select (instantaneous or STEL), or deactivate alarm;
- d) Program parameters or output logged data through a computer.

### 7.3 Run and Logging Mode

The Run Mode is the measurement/logging mode. The user can operate the *personal*DataRAM in this mode either with or without data logging. For example, the instrument may be used first as a survey monitor without logging, for walk-through assessment of an industrial plant, before deciding where to set up the unit for continuous monitoring and logging.

### 7.3.1 Data Logging

In order to activate the logging function, the unit must be in (or returned to) the Ready Mode (see Section 8.2).

If data logging has been enabled, the data will be logged in the next free (unrecorded) tag or data set. For example, if data had been recorded previously in tags # 1, 2 and 3 then, when a new run is initiated, the new data will be stored in tag #4. The data can be separated into number of sets (tags) up to a total of 99.

Any number of individual data points can be stored in a given tag, i.e. up to a maximum of 13,000 points (i.e. the total memory capacity of the *personalDataRAM*) assuming that no other data had been logged in other tags. This means that the total memory capacity of 13,000 data points can be grouped into any number of the available 99 data sets (tags).

### 7.3.2 Clearing of Memory

Data recorded in the *personalDataRAM* memory can be erased either through an external PC command using the Thermo Electron *pDR-COM* Custom Communications software provided as a standard accessory, or resetting the instrument (see Section 8.5). The PC method permits to erase the data in any number of selected tags, whereas the resetting method results in the deletion of all data stored in the *personalDataRAM*.

### 7.3.3 Run Mode Display and Commands

When a measurement run has been initiated (see Section 8.3), the user has the following display choices:

- a) Instantaneous and time-averaged concentrations (both on the same screen);
- b) Elapsed run time, and run start time and date (both on the same screen);
- c) Maximum displayed concentration from run start, and time/date at which current maximum occurred;
- d) Short term excursion limit (STEL) from run start, and time/date at which current STEL occurred;
- e) Remaining battery charge, and (if logging function is enabled) remaining free memory.
- f) Analog output concentration range (if enabled)

The user can command the termination of the run at any time returning it to the Ready Mode. To download logged data into a PC, the *personalDataRAM* must be in the Ready Mode. No changes in the program parameters or operating conditions can be made while in the Run Mode.

The *personalDataRAM* can be shut off from any of the three operating modes. Even if shut off while in the Run Mode, the instrument will save all stored data.

## 8.0 OPERATION

### 8.1 Start-Up

	<b>KEY</b>	<b>DISPLAY</b>	<b>NOTES</b>
1.	<b>ON/OFF</b>	START ZERO:ENTER GO TO RUN: NEXT	Before starting a run with the <i>personalDataRAM</i> , zero it (see Section 6.5) and key <b>ENTER</b> while the unit is exposed to particle-free air. Alternatively, key <b>NEXT</b> to go to RUN/READY mode. If <b>ENTER</b> is keyed:
2.	<b>ENTER</b>	ZEROING V2.00  CALIBRATION: OK  BACKGROUND HIGH  MALFUNCTION	Keep clean air flowing while ZEROING is displayed* for 1.1 min., followed by one of these screens:  or,  or,  If CALIBRATION: OK, then go to step 3. If one of the other two screens is displayed, consult Section 12.0.
3.	<b>NEXT</b>	START RUN: ENTER READY: NEXT	To start a measurement run key <b>ENTER</b> (Section 8.3, step 1). To set up for a run and scroll logging/operating parameters, key <b>NEXT</b> (see Section 8.2).
4.	<b>ON/OFF</b>	TURN OFF PDR? Y:ENTER N:NEXT	Keying <b>ON/OFF</b> while the unit is operating will elicit this message to prevent accidental shut off. To confirm shut down, key <b>ENTER</b> . To continue operation, key <b>NEXT</b> .

\*The number following the V on the screen refers to the installed firmware version.

## 8.2 Setting Up For A Run (Ready Mode)

	KEY	DISPLAY	NOTES
1.	NEXT	LOGGING DISABLED	This screen indicates the logging status. To enable the logging function, key <b>ENTER</b> . Toggling of the on/off logging status can be done by keying ENTER.
2.	ENTER	LOG INTRVL 600s TAG#: 4	<u>This message indicates that logging is enabled.</u> Example is for 10-min log period, selected through the PC (see Section 9.0), and next free tag is #4.
3.	NEXT	ALARM: OFF	This screen indicates the alarm status. Keying <b>ENTER</b> repeatedly toggles through the 3 alarm modes:
4.	ENTER	ALARM: INSTANT LEVEL:1.50 mg/m <sup>3</sup>	This enables the alarm based on the real-time concentration. The level (e.g. 1.50 mg/m <sup>3</sup> ) must be set on the PC.
5.	ENTER	ALARM: STEL LEVEL:0.50 mg/m <sup>3</sup>	This enables the alarm based on the 15-min STEL value. The level (e.g. 0.50 mg/m <sup>3</sup> ) must be set on the PC.
6.	NEXT	ANALOG OUTPUT: DISABLED	This screen indicates the analog signal output status. Keying ENTER will enable the analog output. Toggling the analog output on/off can be done by keying <b>ENTER</b> :
7.	ENTER	ANALOG OUTPUT: 0 – 0.400 mg/m <sup>3</sup>	This enables the analog output. The concentration range (e.g., 0 – 0.400 mg/m <sup>3</sup> ) must be set on the PC.
8.	NEXT	CAL FACTOR: 1.00 DIS AVG TIME 10s	This screen displays the calibration factor and the display averaging time. Edit via PC

9.	<b>NEXT</b>	BATTERY LEFT 83% MEMORY LEFT 96%	This screen displays the remaining battery charge, and the remaining percentage of free memory.
10.	<b>NEXT</b>	CONNECT TO PC	When this screen has been selected, the operating parameters can be edited and/or the logged data can be downloaded via the PC (see Section 9.0). If <b>NEXT</b> is keyed again, the screen returns to RUN/READY:
11.	<b>NEXT</b>	START RUN: ENTER READY: NEXT	The instrument is now ready to run following the procedure in section 8.3.

### 8.3 Measurement Run Procedure

KEY	DISPLAY	NOTES	
1.	<b>ENTER</b>	LOGGING DISABLED  LOG INTRVL 600s TAG #: 4  CONC*0.047 mg/m <sup>3</sup> TWA 0.039 mg/m <sup>3</sup>	or, if logging was enabled:  <u>Logging status will be displayed for 3 seconds.</u>  After a 3-second delay, the concentration screen appears values shown here are examples). CONC is the real-time and TWA is the time-averaged concentration. <u>The “*” appears only if logging has been enabled.</u>
2.	<b>EXIT</b>	TERMINATE RUN? Y:ENTER N:EXIT	To terminate the current run and return to the Ready Mode, key <b>ENTER</b> . To continue the run, key <b>EXIT</b> .
3.	EXIT	CONC*0.047 mg/m <sup>3</sup> TWA 0.039 mg/m <sup>3</sup>	Keying <b>NEXT</b> successively scrolls the display to show various run values (elapsed run time, maximum, STEL, etc.). Keying <b>EXIT</b> returns to the concentration display.

4.	<b>NEXT</b>	ET 06:12:49 ST 08:18:26MAY15	This screen shows the elapsed run time (ET) and the run start time/date (ST).
5.	<b>NEXT</b>	MAX: 0.113 mg/m <sup>3</sup> T 10:08:44 MAY15	This screen shows the maximum concentration of current run and time/date of occurrence.
6.	<b>NEXT</b>	STEL:0.058 mg/m <sup>3</sup> T 09:59:22 MAY15	This screen shows the 15-min STEL value of the current run and the time/date of occurrence.
7.	<b>NEXT</b>	BATTERY LEFT 83%  BATTERY LEFT 83% MEMORY LEFT 96%	or, if logging was enabled:  This screen shows the amount of usable charge left in the battery and, if logging has been enabled, the overall amount of free memory left.
8.	<b>NEXT</b>	ANALOG OUTPUT: 0 – 0.400 mg/m <sup>3</sup>	This screen shows the status of the analog signal output, and the range, if this output has been enabled.
9.	<b>NEXT</b>	CONC*0.047 mg/m <sup>3</sup> TWA 0.039 mg/m <sup>3</sup>	The last <b>NEXT</b> command returns the display to the concentration screen.
10.	<b>EXIT</b>	TERMINATE RUN? Y:ENTER N:NEXT	As indicated in step 2, to end current run, key <b>ENTER</b> , to return to the Ready Mode:
11.	<b>ENTER</b>	START RUN: ENTER READY: NEXT	This keystroke terminates the current run and returns the unit to the Ready Mode.

If during a run the instrument memory is filled completely, or if all 99 tags have been used, the run is automatically terminated and the display will indicate:

RUN TERMINATED  
FULL MEMORY

If a new run is initiated after the memory has been filled, the *personal*DataRAM can be operated only as a monitor without logging. The memory must then be cleared (see Section 7.3.2) first before logging can be enabled again.



## 8.4 Abbreviated Run Start/Stop Instructions

To power-up and start a measurement run without zeroing and without logging, proceed as follows:

- Key sequentially **ON/OFF**, **NEXT** and **ENTER**.

To terminate run and shut down, proceed as follows starting from the concentration screen (otherwise key **EXIT** first):

- Key sequentially **EXIT**, **ENTER**, **ON/OFF** and **ENTER**.

## 8.5 Resetting Procedure

The *personalDataRAM* memory can be reset through commands entered on its own keypad (i.e. without requiring a PC).

Resetting accomplishes the following:

- Erases all stored data from memory;
- Resets all parameters and operating conditions to their default values and conditions; and
- Cancels the zero correction offset.

**WARNING: THE RESET TEST WILL ERASE ALL DATA STORED IN MEMORY AND SET ALL PARAMETERS TO FACTORY DEFAULT SETTINGS. DOWNLOAD ANY DATA BEFORE THE RESET PROCEDURE.**

The procedure to reset the instrument is as follows:

Starting with the unit shut off, press the **EXIT** and **ENTER** keys at the same time, and while holding down those two keys, press **ON/OFF**. The screen will then indicate: PDR SELF-TEST... and several diagnostic screens will appear in rapid sequence (see Section 16.0, Resetting/Electronics Checking Mode), ending in the message TESTING COMPLETE. The unit will shut off. When turned on again, the *personalDataRAM* memory will have been reset, as described above.

The **default** values and operating conditions of the *personalDataRAM* are:

- Logging period (LOG INTRVL): 60 seconds
- Logging status: disabled (LOGGING DISABLED)
- Alarm level: 1 mg/m<sup>3</sup>

- Alarm status: disabled (ALARM: OFF)
- Analog output: 0 to 4 mg/m<sup>3</sup>
- Analog output status: disabled (ANALOG OUTPUT :DISABLED)
- Real-time display averaging time (DIS AVG TIME): 10 seconds
- Calibration factor (CAL FACTOR): 1.00

When turning on the *personalDataRAM* after resetting the instrument, it should be zeroed (see steps 1 and 2 of Section 8.1) before a run is initiated. Otherwise, its internal optical background level will not be subtracted from the indicated concentration readings. Alternatively, if the instrument is not zeroed after resetting, it will indicate its unsubtracted optical background when run under particle free conditions.

## 9.0 COMMUNICATIONS WITH COMPUTER

### 9.1 Hardware and Software Requirements

The computer requirements to install the software provided with the *personalDataRAM* (Thermo Electron *pDR-COM*) are the following:

- IBM-PC compatible
- 486, Pentium, or better processor
- Minimum operating system: Windows 95™ or better
- ≥ 8 MB of RAM
- 2 MB of hard drive space
- CD-ROM drive
- VGA or higher resolution monitor

**NOTE:** When large files are logged in the *personalDataRAM* in one single tag, a faster computer speed is required to handle the data. For example, if all 13,000 data points are logged in one tag, a Pentium I or II processor with a minimum speed of 166 MHz will be required. If, however, the maximum number of data points per tag is 1,000 or below, a 33 MHz, 486 DX processor will suffice.

Thermo Electron custom hardware and software (provided as standard accessories):

- Digital communications cable (Thermo Electron model *pDR-DCC*)
- CD-ROM disk (Thermo Electron model 100034-00)

### 9.2 Software Installation Procedure

To install the Thermo Electron provided software in the computer, proceed as follows:

1. Insert the CD-ROM disk labeled "*pDR-COM*" into computer.

2. For Windows 95™ or higher users, select **Start** and then **Run**.
3. Type in on the **Command Line**: **x: install** (where “x” is the CD-ROM drive).
4. The message "**Do you wish to install pDR-COM?**" will appear. Click **OK** to continue, or **Cancel**.
5. A message appears allowing the option to change the default directory:
6. "**C:\PDRCOM**". It is advisable to leave the default directory (unless you address the hard drive by a different letter), and select **OK**.
7. After a successful installation, the message "**Installation Complete!**" will appear.

### 9.3 Communication Between *personalDataRAM* and Computer

To effect the communication between the *personalDataRAM* (via the *pDR-COM* software installed in the computer as described in the preceding section) and the PC, proceed as follows:

1. Connect the *personalDataRAM* to one of the computer's serial ports using the *pDR-DCC* cable provided by Thermo Electron. This cable has a 9-pin female connector for the computer port.
2. Key **ON/OFF** the *personalDataRAM* and then key **NEXT** repeatedly until **CONNECT TO PC** is displayed on the *personalDataRAM*.
3. On the computer, double click on the **pDR-COM** icon. A four-tabbed notebook display should appear. Click on the **Com Port Select** and select the port to which the *pDR-DCC* cable has been connected.
4. From the four-tabbed notebook displayed on the computer screen select the tab with the desired option. The options are:
  - **Main:** This page allows the user to input the *personalDataRAM* serial number (or any other desired label), and select the Serial Com Port.
  - **Logged data:** This page allows the user to download, tabulate, print data, or transfer to a CSV file the data stored in the *personalDataRAM*. This page also serves to display real-time numerical data when the computer is connected to the *personalDataRAM* in the Run Mode.
  - **Graph data:** This page enables the downloading and graphing of stored data to the computer screen and to a printer. In the Run Mode, this page displays the real-time data in graphic format.
  - **Configure pDR:** This screen allows the user to edit the operating/logging parameters. Click on the item to be edited and select or type in the new value.

To review the parameter values currently programmed into the *personalDataRAM*, click on **Get configuration**. After editing the parameters, click on **Set configuration** to input the new values into the *personalDataRAM* program.

Most operations within *pDR-COM* are self-evidently labeled, including fly-over dialog boxes. In addition, instructions may be found in the On-line Help files by selecting **Help** and then **Contents**.

The following operating/logging parameters of the *personalDataRAM* are selected (edited) via the computer:

- Current date (month and day of the month)
- Current time (hour, minute and second)
- Display averaging time (1 to 60 seconds, in 1-second increments)
- Calibration factor (0.01 to 9.99, in 0.01 increments)
- Logging interval (1 to 14,400 seconds, in 1-second increments)
- Analog output full scale concentration (0.1, 0.4, 1, 4, 10, 40, 100, or 400 mg/m<sup>3</sup>)
- Analog output status (enabled, or disabled) (can also be selected directly through *personalDataRAM* keyboard, see Section 8.2)
- Alarm level (0.001 to 409.599 mg/m<sup>3</sup>, in 1-μg/m<sup>3</sup> increments)
- Alarm mode (Off, Instantaneous, or STEL) (can also be selected directly through *personalDataRAM* keyboard, see Section 8.2)

The serial number of the *personalDataRAM* is transferred automatically to the PC and displayed on its screen.

In addition, the user can input any other identification for the instrument (up to 20 characters).

#### 9.4 Real-Time RS-232 Output

During the RUN mode, the *personalDataRAM* can communicate real-time concentration data through its serial port via the *pDR-COM* software package. This software application decodes the data and displays it on the computer screen in both graphical and tabulated form.

In order to use this output with some other application, the following information will enable the user to decipher the encoded output signal.

The communication settings for the digital output of the *personalDataRAM* are:

- Baud rate: 4800 bps or 9600 bps
- Data bits: 8
- Stop bits: 1
- Parity: none
- Flow control: Xon/Xoff

Every second during a run, the *personalDataRAM* serial port will output a sixteen-character code. It consists of two brackets with 14 hexadecimal digits between them, representing sum check (2 digits), sensed concentration (8 digits), and calibration factor (% , 4 digits). The concentration in  $\mu\text{g}/\text{m}^3$  is obtained by multiplying the sensed concentration times the calibration factor and dividing by 100.

## 10.0 ANALOG SIGNAL OUTPUT

### 10.1 Analog Output Description

The *personalDataRAM* incorporates the capability to provide both a voltage and a current signal output directly proportional to the sensed concentration of airborne particulates. Both these analog signal outputs are concurrently available. These outputs are provided, principally, for fixed-point applications with hard-wired installations, such as for continuous HVAC monitoring and control.

The particulate concentration range corresponding to the output voltage and current ranges (0 to 5 V and 4 to 20 mA) can be user selected (via a PC). The most sensitive range available is 0 to 0.100  $\text{mg}/\text{m}^3$ , and the least sensitive range is 0 to 400  $\text{mg}/\text{m}^3$ . For example, if the user selects the analog output range of 0 to 0.400  $\text{mg}/\text{m}^3$  then the analog output signal levels, at a concentration of 0.200  $\text{mg}/\text{m}^3$ , would be 2.5 V and 12 mA.

Selection of the concentration range of the analog output must be performed on the PC. This range is independent of the digital display, data logging and real-time digital output range which are controlled automatically (auto-ranging).

Enabling the analog output increases the current consumption from the power source (battery or power supply) of the *personalDataRAM* by typically 5 mA when no load is connected to the analog signal current output. If such a load is connected then the current consumption of the *personalDataRAM* further increases by the magnitude of the output signal current (up to a maximum increment of 20 mA). Therefore, when not using the analog output, it is advisable to disable that output (see Section 8.2) in order to minimize power consumption (this is important only when powering the *personalDataRAM* from a battery source).

### 10.2 Analog Output Connection

The *personalDataRAM* is provided with a cable (model *pDR-ANC*) which has a 6-contact plug at one end and flying leads at the other. There are 4 leads for the analog and alarm outputs. The additional two contacts of the connector are used only for digital communication with a PC, for which a separate cable (model *pDR-DCC*) is provided.

Counting from top to bottom on the *personalDataRAM* connector receptacle, contact #1 is the positive 4 – 20 mA analog output, contact #2 is the alarm output, contact #5

is the common ground (return for all signals), and contact #6 is the positive 0 – 5 V analog output.

For the 0 – 5 V output signal, the externally connected load must have an impedance of more than 200 kilo-ohms. For the 4 – 20 mA output signal, the externally connected load must have an impedance of less than 200 ohms when powering the *personalDataRAM* with a battery, or less than 300 ohms when using the its AC supply.

Since both voltage and current outputs are present at the same time, both can be used concurrently, if so required.

The accuracy of the analog output signals is better than 1% of the reading with respect to the digital reading.

## **11.0 ALARM**

### **11.1 Alarm Description and Operation**

The *personalDataRAM* alarm function is provided both as an audible signal as well as an electrical output. The audible alarm consists of a series of beeps generated by an on-board piezo-transducer. The electrical output, available at the digital communications port, consists of a 1 Hz square wave signal which can be used to trigger/activate other equipment through an appropriate interface (consult with the factory).

The alarm function can be enabled/disabled by the user through the *personalDataRAM* keyboard (see Section 8.2). Setting of the alarm level must be performed on the PC (see Section 9.0).

The alarm is triggered whenever the preset alarm level is exceeded based either on: a) the displayed real-time concentration, if ALARM: INSTANT was selected (see Section 8.2), or b) a 15-minute running average concentration, if ALARM: STEL was selected. When the concentration falls below that level the alarm condition stops. While the alarm is on the user can stop it (i.e. silence the alarm) by pressing any key of the *personalDataRAM*. If the concentration continues to exceed the set alarm level after 10 seconds, however, the alarm restarts.

### **11.2 Alarm Output**

A pulsed voltage output is available on the *personalDataRAM* in synchronism with the audible signal. This signal consists of a 1 Hz square wave with an amplitude level of 5 V pp. An externally connected load should have an impedance of no less than 100 kilo-ohms. This alarm output signal is available at pins 2 and 5 (counting from top to bottom) of the 6-contact output/communications port on the side of the *personalDataRAM* (see Figure 5 or 6).

### 11.3 Remote Alarm Unit

An alarm relay unit (Thermo Electron model *pDR-RA*) is available as an optional accessory for the *personalDataRAM*. The *pDR-RA*, when connected to the alarm output of the *personalDataRAM*, provides a switched output triggered by the alarm signal of the monitor. This switched output (up to 8 amperes, 250 volts) can be used to activate or deactivate other equipment (e.g. ventilation systems, machinery, etc.), or to control remotely located (by wire connection) alarm indicators (e.g. buzzers, lights, etc.).

## 12.0 MAINTENANCE

### 12.1 General Guidelines

The *personalDataRAM* is designed to be repaired at the factory. Access to the internal components of the unit by others than authorized personnel voids warranty. The exception to this rule is the occasional cleaning of the optical sensing chamber.

Unless a MALFUNCTION message is displayed, or other operational problems occur, the *personalDataRAM* should be returned to the factory once every two years for routine check out, testing, cleaning and calibration.

### 12.2 Cleaning of Optical Sensing Chamber

Continued sampling of airborne particles may result in gradual build-up of contamination on the interior surfaces of the sensing chamber components. This may cause an excessive rate of increase in the optical background. If this background level becomes excessive, the *personalDataRAM* will alert the user at the completion of the zeroing sequence, as indicated in Section 8.1, by the display of a BACKGROUND HIGH message. If this message is presented, the *personalDataRAM* can continue to be operated providing accurate measurements. However, it is then advisable to clean the interior of the sensing chamber at the first convenient opportunity, proceeding as indicated below.

#### 12.2.1 Model *pDR-1000AN*

- Remove the two screws on the top of the large protective bumper that covers the sensing chamber (see Figure 1);
- Remove the large protective bumper by lifting it firmly upwards and away from the sensing chamber;
- Remove the socket-head screws on the front and back black covers that were exposed by removal of the large top bumper. Lift away the freed front and back covers of the sensing chamber; set them aside carefully and such that they can be reattached in the same position as they were previously; avoid touching the dull black side of these plates;

- Using filtered (particle-free) pressurized air, blow the inside of the sensing chamber taking great care in not marring or scratching any of the exposed surfaces;
- Reposition the two sensing chamber cover plates in the same location (front and back) as they had been originally. Insert and tighten socket head screws firmly making sure that the two plates are aligned perfectly with the top of the sensing chamber;
- Reposition large protective bumper over sensing chamber pushing down until properly seated. Insert the two top screws holding down the bumper and tighten gently (do not over-tighten);
- Check optical background by zeroing the *pDR-1000AN* as indicated in Section 8.1. If the sensing chamber cleaning was performed correctly, the message CALIBRATION: OK should be displayed at the end of the zeroing period.

### **12.2.2 Model *pDR-1200***

- Remove the two screws (one in the front and one in the back) holding the front and back gasketed covering plates of the sensing chamber, and set these plates aside, such that they may be reattached in the same location as they were previously.
- Using filtered (particle-free) pressurized air, blow the inside of sensing chamber taking great care in not marring or scratching any of the exposed surfaces.
- Reposition the two sensing chamber cover plates in the same location (front and back) as they had been originally. Insert and tighten socket head screws firmly making sure that the two plates are aligned perfectly with the top of the sensing chamber.
- Check optical background by zeroing the *pDR-1200* as indicated in Section 8.1. If the sensing chamber cleaning was performed correctly, the message CALIBRATION: OK should be displayed at the end of the zeroing period.

### **12.3 Cyclone Cleaning (Model *pDR-1200* only)**

The cyclone will require occasional cleaning. It is advisable to do so whenever the sensing chamber of the *pDR-1200* is cleaned (see above). To clean the cyclone, remove it from its black attachment cup on the sensing chamber, and unscrew the grit pot (narrower knurled end). Use clean pressurized air to blow out the grit pot and through all openings of cyclone body. Reattach grit pot to cyclone body and insert cyclone body into attachment cup making sure it is fully inserted.

## **13.0 CALIBRATION**

### **13.1 Factory Calibration**

Each *personalDataRAM* is factory calibrated against a set of reference monitors that, in turn, are periodically calibrated against a gravimetric standard traceable to the National Institute of Standards and Testing (NIST).



The primary factory reference method consists of generating a dust aerosol by means of a fluidized bed generator, and injecting continuously the dust into a mixing chamber from which samples are extracted concurrently by two reference filter collectors and by two master real-time monitors (Thermo Electron DataRAM 4) that are used for the routine calibration of every *personalDataRAM*.

The primary dust concentration reference value is obtained from the weight increase of the two filters due to the dust collected over a measured period of time, at a constant and known flow rate. The two master real-time monitors are then adjusted to agree with the reference mass concentration value (obtained from averaging the measurements of the two gravimetric filters) to within  $\pm 1\%$ .

Three primary, NIST traceable, measurements are involved in the determination of the reference mass concentration: the weight increment from the dust collected on the filter, the sampling flow rate, and the sampling time. Additional conditions that must be met are: a) suspended dust concentration uniformity at all sampling inlets of the mixing chamber; b) identical sample transport configurations leading to reference and instrument under calibration; and c) essentially 100% collection efficiency of filters used for gravimetric reference for the particle size range of the test dust.

The test dust used for the Thermo Electron factory calibration of the *personalDataRAM* is SAE Fine (ISO Fine) supplied by Powder Technology, Inc. It has the following physical characteristics (as dispersed into the mixing chamber):

- Mass median aerodynamic particle diameter: 2 to 3  $\mu\text{m}$
- Geometric standard deviation of lognormal size distribution: 2.5
- Bulk density: 2.60 to 2.65  $\text{g}/\text{cm}^3$
- Refractive index: 1.54

### **13.2 Field Gravimetric Calibration**

If desired, the *personalDataRAM* can be calibrated gravimetrically for a particular aerosol (dust, smoke, mist, etc.) under field conditions (actual conditions of use). To effect such calibration in the particle environment of interest, proceed as indicated below.

For field calibration of the model *pDR-1000AN*, a personal type filter sampler is placed side-by-side (collocated) to the *pDR-1000AN* to be calibrated, and the two units should be started simultaneously. For the model *pDR-1200*, its own filter and attached pump can be conveniently used for the same purpose.

- Weigh and load into filter holder a fresh membrane filter.
- Start pump.
- Immediately turn on *personalDataRAM* and start a run such that the pump and the *personalDataRAM* are started nearly simultaneously.

The duration of this comparison run should be sufficient to collect a mass of at least 1 mg on the reference filter (in order to permit accurate weighing of the collected mass by means of an analytical balance). The time-weighted average (TWA) reading of the *personalDataRAM* can be used to estimate the required sampling time to collect the above-mentioned mass on the filter. To estimate the required sampling time (ET as measured on the *personalDataRAM*) in minutes, read the TWA value (see Section 8.3) after an elapsed time (ET) of one minute or more, and apply the following relationship:

$$ET \geq 500/TWA$$

For example, if  $TWA = 2.5 \text{ mg/m}^3$ , then  $ET \geq 200$  minutes (approximately 3 hours). If the TWA value changes significantly as the run proceeds, recalculate the required ET accordingly.

At the end of the run (after time ET has elapsed), record TWA, ET and the flow rate Q used to sample the air. Weigh the filter on an analytical balance and obtain  $\Delta m$ , the mass increment due to the collected particles.

Calculate the average gravimetric concentration C, as follows:

$$C = 1000 \Delta m/ET \times Q$$

Compare the recorded value of TWA and the calculated value C, and calculate the calibration factor to be programmed into the *personalDataRAM* (see Section 9.0) as follows:

$$\text{CAL FACTOR} = C/TWA$$

For example, if C was found to be  $3.2 \text{ mg/m}^3$ , and TWA had been determined to be  $2.5 \text{ mg/m}^3$ , the CAL FACTOR equals 1.28. Select this value on the PC, as described in Section 9.0. This completes the gravimetric calibration of the *personalDataRAM* for a specific aerosol.

### 13.3 Scattering Coefficient Calibration

Users interested in using the *personalDataRAM* for scattering coefficient measurements (e.g., for atmospheric visibility monitoring) should contact the factory. A special primary Rayleigh scattering calibration for such purpose can be performed by the factory.

### 13.4 Internal Span Check

The zeroing procedure (see Section 8.1) and the resulting normal diagnostic display of "CALIBRATION: OK" (step 2) informs the user that the instrument's calibration agrees with the original factory setting. This is an internal span check that consists of an automatic comparison between the initial (factory) optical background of the *personalDataRAM* (registered in its non-volatile memory), and the current optical background sensed during the zeroing sequence.

## 14.0 PARTICLE SIZE CLASSIFICATION (model *pDR-1200* only)

The particle size selective cyclone of the *pDR-1200* provides the user with two important capabilities: a) to measure the particulate matter concentration of a specific aerodynamic size fraction, and b) to determine the mass median size of a particle population. These two applications will be discussed in what follows. For both these applications, a variable measured flow rate pump is required, such as the model *pDR-PU* (for which a separate instruction manual is provided).

### 14.1 Size Fractionated Monitoring

The *pDR-1200* can be used to monitor a specific particle size fraction below a selectable cut off equivalent aerodynamic diameter. The particle size cut point can be selected by adjustment of the sampling flow rate. The higher the flow rate through the cyclone the smaller the cut off particle diameter. Figure 7 is a graph showing the dependence of the particle cut off size in micrometers as a function of the sampling flow rate in liters per minute. The cut off size is the particle aerodynamic diameter at which the collection efficiency of the cyclone is 50%, or conversely, the size at which the cyclone transmission is 50%. For example, to obtain a particle size cut off of 2.5  $\mu\text{m}$  (i.e., PM<sub>2.5</sub>), the required sampling flow rate is 4 liters/minute. At that flow rate only particles smaller than (approximately) 2.5  $\mu\text{m}$  are allowed to pass into the *pDR-1200* sensing stage, to be monitored and then to be collected on the filter.

As can be seen on Fig. 7, the lowest particle size cut for the GK 2.05 cyclone included with the *pDR-1200* is about 1  $\mu\text{m}$ , and the largest is about 12  $\mu\text{m}$ . For particle size classification outside this range, consult with the factory.

### 14.2 Particle Sizing

The selectable particle size capability of the cyclone, in combination with the concentration measuring capability of the photometric system of the *pDR-1200* permits the user to determine the mass median aerodynamic particle diameter of an aerosol, i.e., of the airborne particle population being sampled.

One simple procedure to determine the median particle size is as follows (please refer to the graph of Fig. 7):

- Remove cyclone from its black attachment cup and set cyclone aside
- Start pump and sample aerosol at a flow rate between 2 and 4 liters/minute
- Press ON key on *pDR-1200* panel and after about one minute key NEXT and then ENTER
- After an elapsed time (ET) of about one minute, read and note TWA concentration
- Shut off pump
- Plug in cyclone into its attachment cup

- Start pump and run at about 1 liter/minute. Observe real-time concentration (CONC) reading
- Increase flow rate very slowly and gradually until CONC reading is one-half of the initial concentration measured without the cyclone. Continue sampling at this flow rate for about one minute and confirm that TWA reading is about one-half of the initial one. Otherwise readjust flow rate. Note final flow rate at which the TWA value has decreased to one-half the value noted without the cyclone.
- Enter the final flow rate for which the TWA value is one-half of the initial value into the graph of Fig. 7 and read the corresponding D50 particle size in micrometers. This represents the mass median particle diameter of the aerosol.

For example, if the TWA value without the cyclone was  $0.8 \text{ mg/m}^3$ , and the flow rate (with the cyclone attached) required to reduce the TWA to  $0.4 \text{ mg/m}^3$  is 2 liters/minute, the mass median particle size (as obtained from the curve of Fig. 7) is approximately  $5.5 \text{ }\mu\text{m}$ .

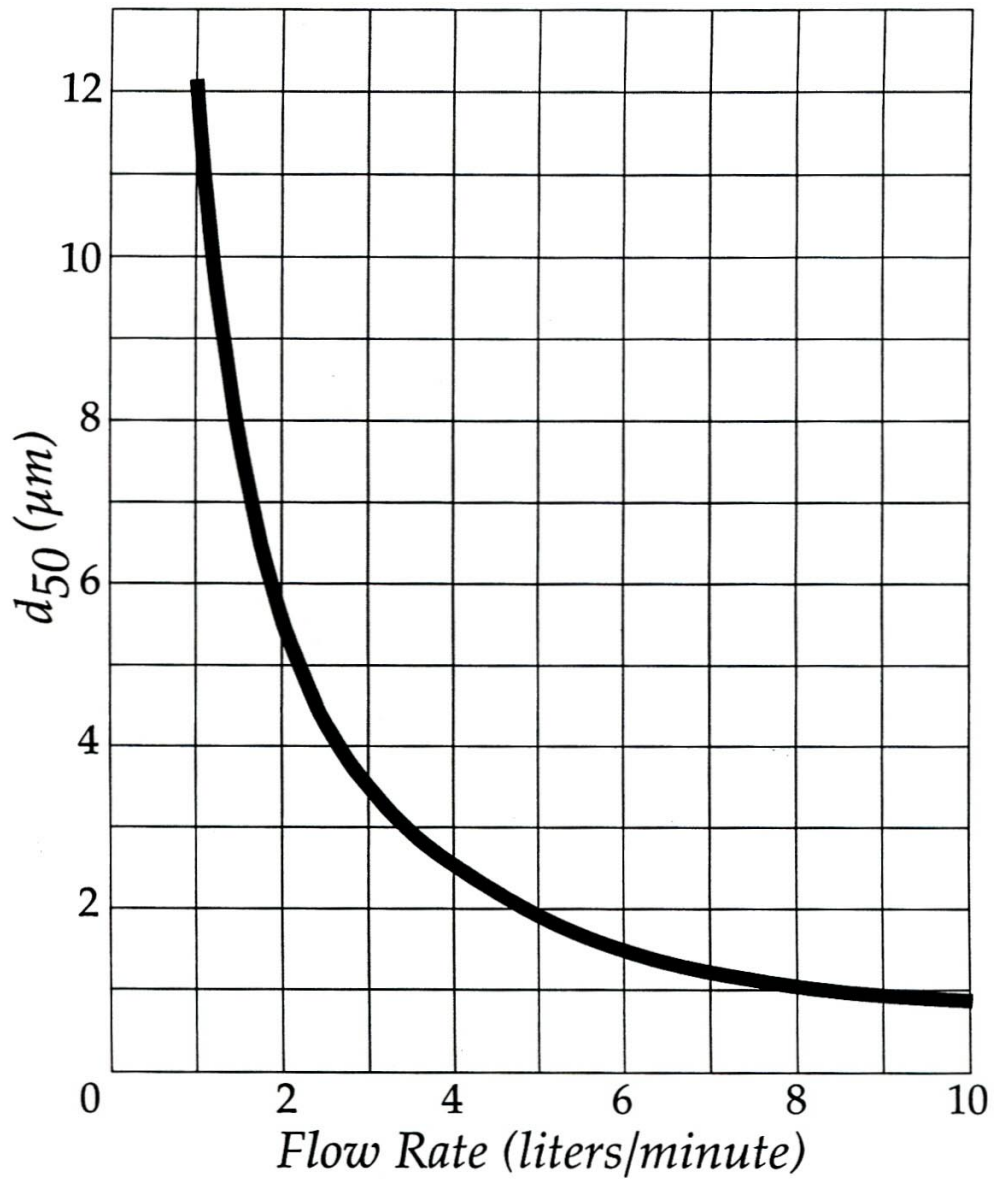

**Figure 7. GK 2.05 Cyclone Cut Point ( $d_{50}$ ) as a Function of Flow Rate**

## 15.0 CONVERSION BETWEEN *personalDataRAM* VERSIONS

The *personalDataRAM* user has the option to convert from a model *pDR-1000AN* to a model *pDR-1200* or vice versa using the appropriate conversion kit. To convert from a *pDR-1000AN* to a *pDR-1200* (i.e., from a passive air sampling configuration to an active one), the user requires the model *pDR-AS* conversion kit. To convert from a *pDR-1200* to a *pDR-1000AN* (i.e., from an active air sampling configuration to a passive one), the user requires the model *pDR-UB* conversion kit.

### 15.1 Conversion Procedure From *pDR-1000AN* to *pDR-1200*

To effect this conversion, use model *pDR-AS* conversion kit. As you remove parts from the *pDR-1000AN*, in order to attach the conversion kit components, store these parts carefully for possible future re-conversion. Proceed as follows:

- Remove the two screws on the top of the large protective bumper that covers the sensing chamber (see Figure 1). This bumper is not used on the *pDR-1200*;
- Remove the large protective bumper by lifting it firmly upwards and away from the sensing chamber;
- Reinsert in the upper two threaded holes and tighten the two screws that had held the protective bumper;
- Remove the socket-head screws on the front and back black covers that were exposed by removal of the large top bumper. Lift away the freed front and back covers of the sensing chamber; store them carefully for future use, ensuring that their surfaces are not scratched or marred;
- Position one of the two gasketed (soft rubber) sensing chamber cover plates provided in the conversion kit on the front side of the sensing chamber. Insert and tighten the included socket head screw firmly making sure that the plate is aligned perfectly with the top of the sensing chamber. Similarly, attach the other cover plate on the back side of the sensing chamber;
- Identify the two black cups of the *pDR-AS* conversion kit. One of them has an external o-ring (filter holder cup), and the other has no o-ring (cyclone cup); refer to Figures 2 and 4 for the location of these cups on the *pDR-1200* sensing chamber. These cups can be installed on either side of the sensing chamber, i.e., the cyclone can be either on the left or the right side of the sensing chamber (Figure 2 shows the case where the cyclone is on the right side);
- Attach one cup to the left side of the sensing chamber using the two black socket head screws. Tighten screws firmly. Similarly, attach the other cup to the right side of the sensing chamber;
- Take the cyclone/filter holder unit provided as part of the conversion kit, and separate the 37-mm plastic filter holder from the metal cyclone by firmly pulling the two units apart;
- Carefully slide the large open end of the plastic filter holder over the cup with the external o-ring, previously attached to the sensing chamber. Ensure that the cup is fully inserted into the filter holder;

- Carefully insert the large diameter open end of the metal cyclone into the other cup on the opposite side of the sensing chamber. The cyclone inlet (small short metal tube on side of cyclone) can be oriented as desired (upwards, as shown in Figure 2, sideways, downwards, etc.). Ensure that the cyclone is fully inserted into the cup;
- When ready to operate, connect a length of tubing between the barbed fitting at the downstream end of the plastic filter holder and the pump to be used in combination with the *pDR-1200*.
- Perform a zeroing sequence (see Sections 6.5.2 and 8.1) before starting a run. This completes the conversion of the *pDR-1000AN* to the *pDR-1200*.

## 15.2 Conversion Procedure from *pDR-1200* to *pDR-1000AN*

To effect this conversion use model *pDR-UB* conversion kit. As you remove parts from the *pDR-1200*, in order to attach the conversion kit components, store these parts carefully for possible future re-conversion. Proceed as follows:

- Pull off both the cyclone and the filter holder from their respective cups on the two sides of the sensing chamber;
- Loosen the two screws that hold each of the two cups on the sides of the sensing chamber (total of 4 screws), and remove the two side cups;
- Loosen the single screw on each of the two (front and back) gasketed sealing covers enclosing the sensing chamber, and remove the two covers;
- Identify the two flat sensing chamber cover plates provided in the conversion kit; one face of each of each of these two plates has a dull black finish (antireflective); avoid touching those surfaces;
- Position one of the two sensing chamber cover plates over the open front of the sensing chamber with the dull surface on the inside, and such that the hole in the plate is aligned with the corresponding threaded mounting hole on the upper wall of the sensing chamber. Insert and tighten firmly black socket head screw provided with the conversion kit, making sure that the plate is aligned perfectly with the top of the sensing chamber. Similarly, attach the other cover plate to the rear of the sensing chamber, with the dull surface facing inward;
- Loosen and remove the two small screws on the top surface of the sensing chamber;
- Position large protective bumper (provided in the conversion kit) over sensing chamber pushing down until properly seated. Insert the two top screws (two shiny Phillips-head screws provided in the conversion kit) into the two holes in the bumper while holding down the bumper, and tighten gently (do not over-tighten) making sure that the heads of these screws are well inside their cavities in the bumper;
- Perform a zeroing sequence (see Sections 6.5.1 and 8.1) before starting a run. This completes the conversion from a *pDR-1200* to a *pDR-1000AN*.

**16.0 SEQUENCE OF KEYSTROKES AND SCREENS**  
**(pDR-1000AN/1200, ADR-1200S and HPM-1000)**  
**Start-Up and Survey Run Mode (Without Data Logging)**

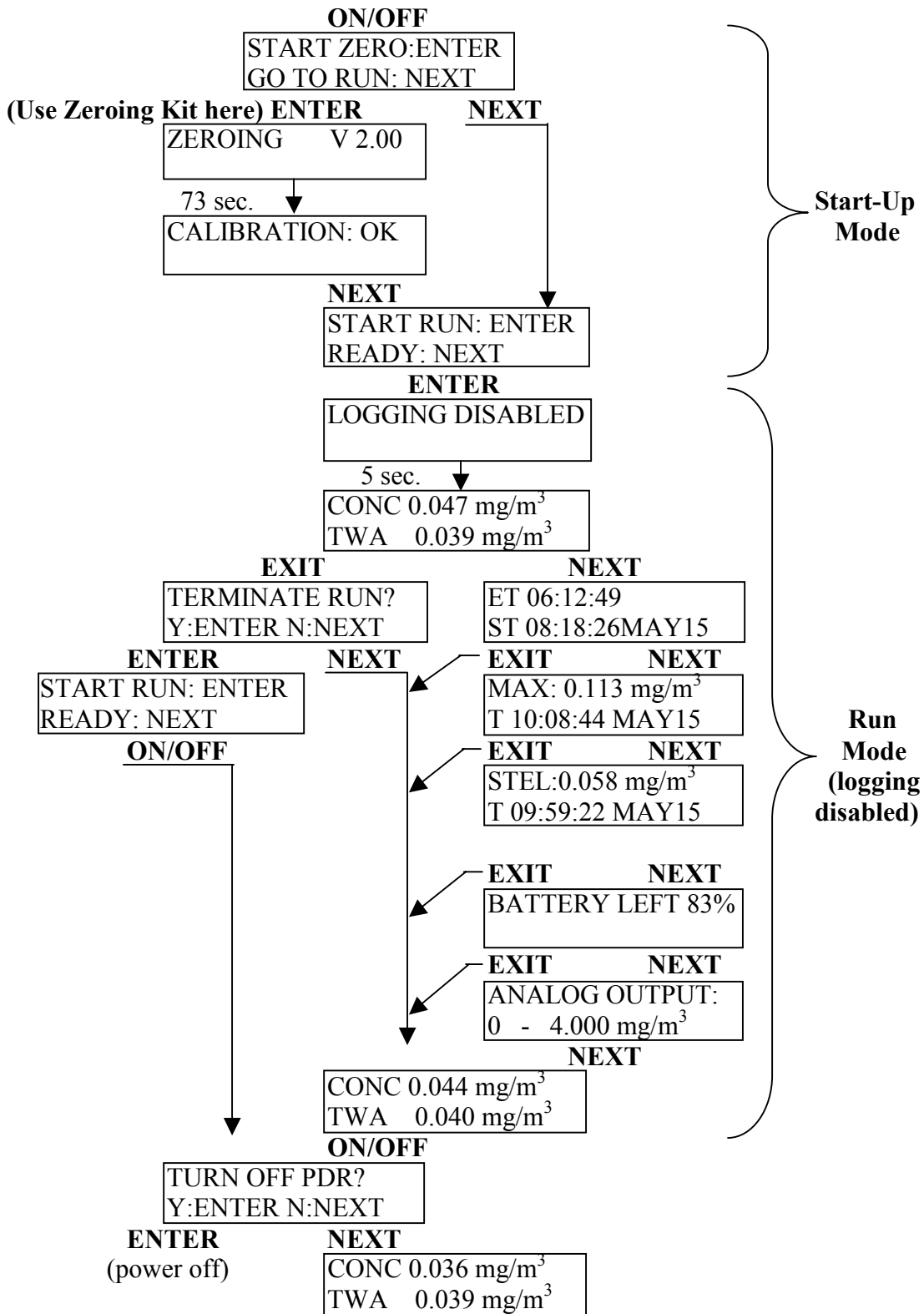



## Start-Up, Set-Up and Run Mode (With Data Logging)

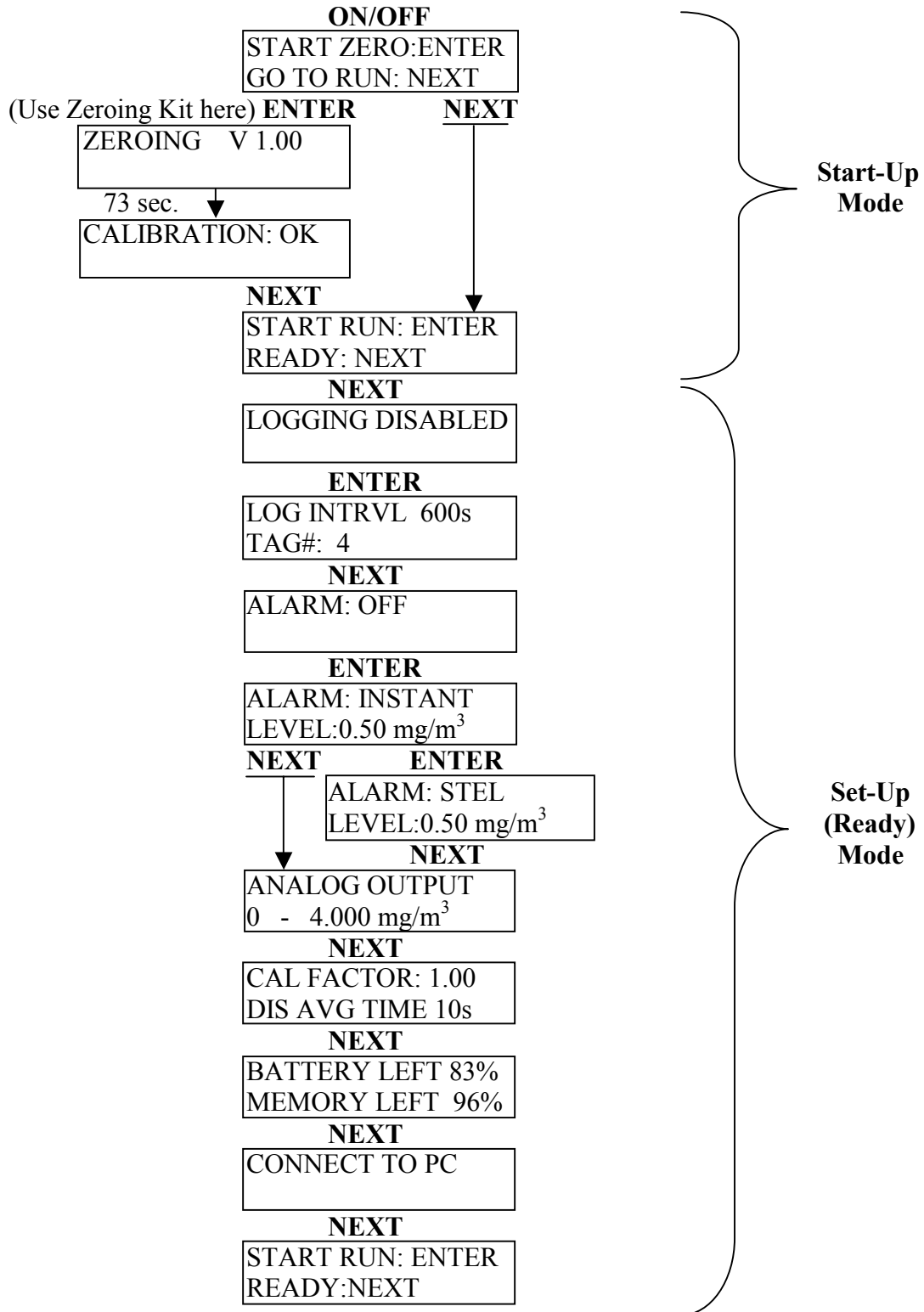

(Continues on next page)

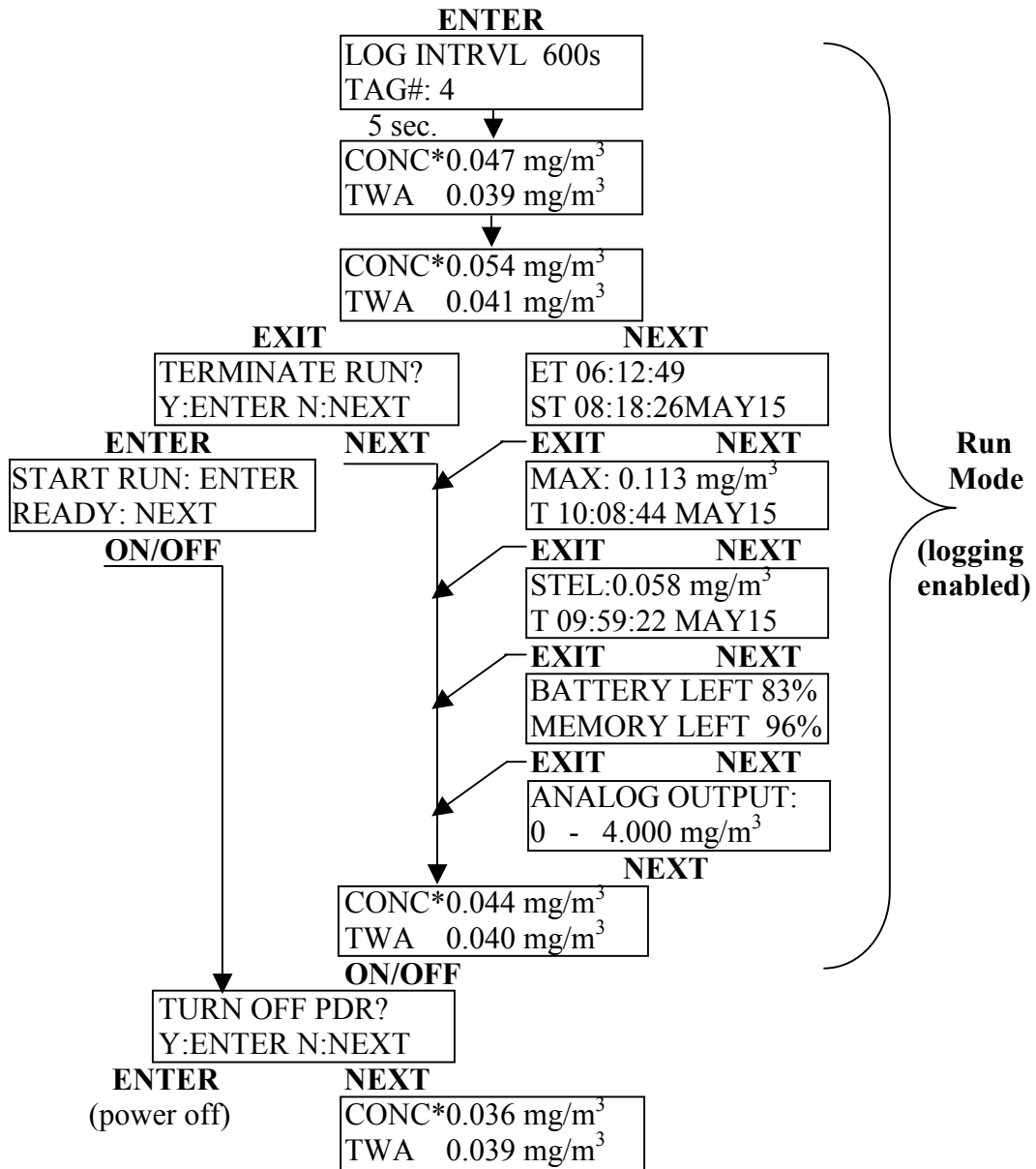

## Resetting/Electronic Checking Mode

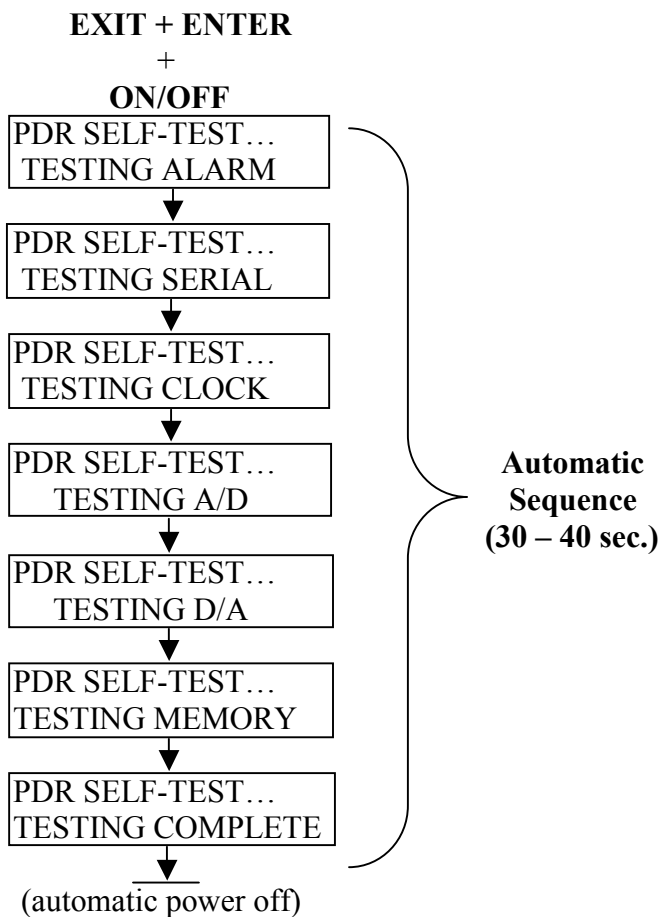

**NOTE:** After the preceding resetting sequence, the instrument should be zeroed; otherwise its optical background will remain unsubtracted.

---

## **17.0 SERVICE LOCATIONS**

For additional assistance, Environmental Instruments Division has service available from exclusive distributors worldwide. Contact one of the phone numbers below for product support and technical information.

**866-282-0430 Toll Free**  
**508-520-0430 International**