

United States
Environmental Protection
Agency

Office of Air Quality
Planning and Standards
Research Triangle Park, NC 27711

89018 014
EPA-451/R-93-012
September 1993

Air/Superfund



AIR/SUPERFUND NATIONAL TECHNICAL GUIDANCE STUDY SERIES

OPTIONS FOR DEVELOPING AND EVALUATING MITIGATION STRATEGIES FOR INDOOR AIR IMPACTS AT CERCLA SITES

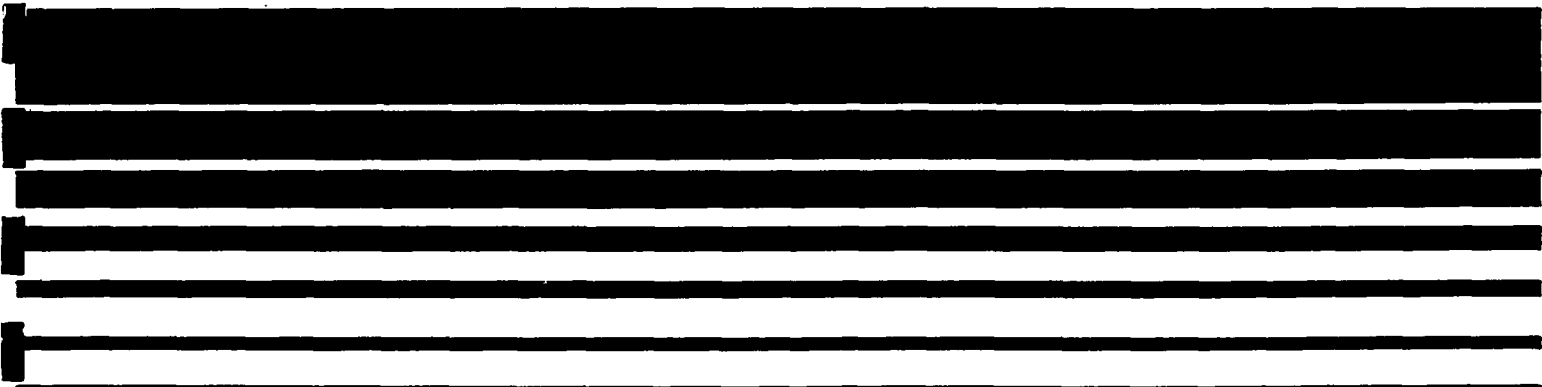

DISCLAIMER

NOTICE: The materials and descriptions compiled for this paper are not to be considered Agency guidance or policy, but are provided for informational and discussion purposes only. They are not intended, nor can they be relied upon, to create any rights enforceable by any party in litigation with the United States. Mention of companies, trade names, or commercial products does not constitute endorsement or recommendation for use.

AIR/SUPERFUND NATIONAL TECHNICAL
GUIDANCE STUDY SERIES
Report ASF-36

OPTIONS FOR DEVELOPING AND EVALUATING MITIGATION STRATEGIES
FOR INDOOR AIR IMPACTS AT CERCLA SITES

Contract No. 68D30032
Work Assignment No. 4

Work Assignment Manager
Kathy Diehl, U.S. EPA Region IX

U.S. Environmental Protection Agency
Office of Air Quality Planning and Standards
Research Triangle Park, North Carolina 27711

September 1993

TABLE OF CONTENTS

DISCLAIMER	i
TABLES	iv
FIGURES	iv
1.0 INTRODUCTION	1-1
1.1 BACKGROUND	1-1
1.2 PURPOSE	1-1
1.3 SCOPE	1-2
1.4 RELATIONSHIP TO EXISTING REGULATIONS AND GUIDANCE	1-2
2.0 MITIGATION TECHNIQUES	2-1
2.1 CONTAMINANT PATHWAYS	2-1
2.2 TECHNICAL MEASURES	2-3
2.2.1 Source Removal	2-3
2.2.2 Prevention of Soil Gas Entry	2-4
2.2.3 Removal From Indoor Air	2-29
2.2.4 Techniques for New Construction	2-38
2.3 INSTITUTIONAL	2-46
2.3.1 Governmental ICs	2-49
2.3.2 Proprietary Institutional Controls	2-51
3.0 DEVELOPING AND SELECTING MITIGATION STRATEGIES	3-1
3.1 DEFINING THE OBJECTIVE	3-2
3.1.1 Mitigation Level Desired	3-4
3.1.2 Reduce Impacts for Current Property Usage	3-5
3.1.3 Prevent/Reduce Impact for Future Property Usage	3-5
3.2 BASIC INFORMATION NEEDS	3-5
3.2.1 Source Type, Strength, Route of Impact	3-6
3.2.2 Building Structural Features	3-9
3.2.3 Current and Potential Future Uses	3-12
3.3 EVALUATION OF OPTIONS	3-13
3.3.1 Estimated Effectiveness of Potential Technical Measures	3-13
3.3.2 Estimated Effectiveness of Institutional Controls	3-18
3.4 DEVELOPING MITIGATION STRATEGY ALTERNATIVES	3-21
3.4.1 Combinations of Mitigation Options Meeting/Exceeding Objectives ..	3-21
3.4.2 Probable costs to Implement and Operate	3-46
4.0 EVALUATING A PROPOSED MITIGATION STRATEGY	4-1
4.1 OBJECTIVE OF EVALUATION	4-1
4.2 REVIEW SITE RELATED INFORMATION	4-1
4.2.1 Contaminant Source and Route of Impact	4-2
4.2.2 Duration of Impacts	4-2
4.2.3 Comparison of Site Information to the Strategy	4-3
4.3 REVIEW IMPACTED STRUCTURE/AREA INFORMATION	4-6
4.3.1 Developed vs Undeveloped Land	4-8
4.3.2 Current and Potential Future Uses	4-9
4.3.3 Measured and Estimated Level of Impact	4-9

	4.3.4	Structural Characteristics	4-9
	4.3.5	Proposed Technical and Institutional Controls	4-11
	4.3.6	Completion of Review	4-11
4.4		REVIEW PROPOSED MITIGATION STRATEGY TECHNIQUES	4-13
	4.4.1	Comparability to Strategies Used in Similar Cases	4-13
	4.4.2	Applicable to Specific Case	4-15
	4.4.3	Reduction Estimates Reasonable	4-16
	4.4.4	Cost Estimates Reasonable	4-16
	4.4.5	Enforceability	4-17
5.0		EVALUATING EFFECTIVENESS OF IMPLEMENTED MITIGATION STRATEGY	5-1
	5.1	TECHNICAL EFFECTIVENESS	5-2
		5.1.1 Direct Indoor Air Measurements	5-2
		5.1.2 Diagnostic Testing for Effectiveness	5-4
		5.1.3 Diagnostic System Testing with Corrective Action	5-5
	5.2	INSTITUTIONAL CONTROLS	5-10
APPENDIX		CASE STUDIES	A-1

LIST OF TABLES

<u>Table</u>		
2.1	Factors Contributing to the Driving Force For Soil Gas Entry	2-7
2.2	Possible Soil Gas Entry Routes Into a Typical House	2-9
2.3	Sealing of Entry Routes	2-11
2.4	Sealant Manufactures/Suppliers	2-12
2.5	Sealant Information	2-13
2.6	Drain Tile Soil Ventilation (Active)	2-20
2.7	Sub-Slab Soil Ventilation (Active)	2-24
2.8	Block Wall Ventilation (Active)	2-26
2.9	Sub-Slab Soil Ventilation (Passive)	2-29
3.1	Technical Control Options	3-16
3.2	Institutional Control Options	3-23
3.3	Master Matrix Table	3-27
3.4	Strategy 1 Matrix Table	3-31
3.5	Strategy 2 Matrix Table	3-34
3.6	Strategy 3 Matrix Table	3-37
3.7	Strategy 4 Matrix Table	3-42
3.8	Strategy 5 Matrix Table	3-45
4.1	Example Format for Comparison of Site Information	4-4
4.2	Example Review of Site Information	4-7
4.3	Example Format for Reviewing Impacted Structure/Area Information	4-8
4.4	Example Reviewing Impacted Structure/Area Information	4-14

LIST OF FIGURES

<u>Figure</u>		
2-1	Negative Pressure Sources in a Typical House	2-6
2-2	Major Soil Gas Entry Routes	2-8
2-3	Theory of Operation of a Sub-slab Depressurization System	2-16
2-4	Drain Tile Ventilation Where Tile Drains to Sump	2-18
2-5	Sub-slab Suction Using Pipes Inserted Through Foundation Wall	2-21
2-6	Sub-slab Suction Using Pipes Inserted Down Through Slab	2-22
2-7	Wall Ventilation with Individual Pressurization Point Walls	2-25
2-8	Passive Sub-slab Ventilation System	2-28
2-9	Possible Configuration for a Fully Ducted HRV	2-33
2-10	New Construction Techniques	2-39
2-11	Post Construction Soil Gas Removal	2-40
2-12	Passive Sub-slab Ventilation System	2-42
2-13	Summary of Mechanical Barrier Approach	2-43
2-14	Methods to Reduce the Vacuum Effect	2-47
3-1	Mitigation Strategy Development	3-3
3-2	Strategy 1 - Most Technical	3-28
3-3	Strategy 2 - Best Technical	3-32
3-4	Strategy 3 - Least Technical	3-35
3-5	Strategy 4 - Most ICs	3-39
3-6	Strategy 5 - Best ICs	3-44

SECTION 1 INTRODUCTION

1.1 BACKGROUND

The Comprehensive Environmental Response, Compensation, and Liability Act of 1980 (CERCLA or "Superfund") and its reauthorization in the Superfund Amendments and Reauthorization Act (SARA) of 1986 established a national program for responding to releases of hazardous substances into the environment. The mandate of the CERCLA program is to protect human health and the environment from current and potential threats posed by these releases.

Occupants of existing structures proximate to a CERCLA site may be exposed to the released chemicals from their transport into the indoor environment. The potential also exists for similar exposures to occupants of future structures proximate to the site. Mitigation may be needed when investigations of the site and proximate areas demonstrated that these exposures reach levels determined unacceptable for occupants of current structures, or are likely to be reached for occupants of potential new structures.

Many EPA Regions have sites where such impacts have occurred and mitigation has been required. Methods used to select the mitigation procedure(s) for those impacts vary within and among Regions. Although information and reference documents exist for mitigation techniques for certain types of impacts, most notably for radon, no information or guidance document exists for developing or evaluating indoor air impact mitigation strategies.

1.2 PURPOSE

The purpose of this document is to present and analyze approaches that may be used to mitigate CERCLA site impacts on the indoor air quality of nearby structures. This document is based on relevant published literature, information on specific cases made available by EPA, and expertise

and experience provided by its review committee. The document is designed to provide information that may assist in resolution of indoor air quality concerns at CERCLA sites. The procedures and methods, however, may also be useful in developing mitigation strategies for indoor air impacts from other hazardous wastes and hazardous materials sources.

1.3 SCOPE

This document assumes that the need for mitigation of indoor air impacts related to the site has been established. Assessment procedures are, therefore, not included. The reader may refer to the Air/Superfund National Technical Guidance Study Series Report "Assessing potential Indoor Air Impacts for Superfund Sites", EPA-451/R-92-002, for assistance in assessing the potential impacts.

This document focuses primarily on mitigation methods which may be applied in the immediate vicinity of the impacted or potentially impacted structure(s). Reference is made to CERCLA site remediation methods which may also have a beneficial impact on indoor air quality, but these are not discussed in detail here. The document includes summary level information on technical methods to prevent or reduce the intrusion of site related chemicals into the indoor environment and institutional methods to restrict the use of developed and undeveloped property to the extent necessary to reduce risks to acceptable levels.

1.4 RELATIONSHIP TO EXISTING REGULATIONS AND GUIDANCE

This document provides supplemental information to assist the reviewer in focusing on mitigation of indoor air impacts occurring at a CERCLA site using techniques that involve little or no treatment to reduce or prevent indoor air exposures. This document assumes that other actions designed to eliminate the contaminants at the site through treatment or removal may be occurring that also reduce or eliminate indoor air impacts.

The RI/FS guidance requires that, while developing alternatives, screening procedures be used that consider effectiveness, implementability, and costs for media-specific technologies and to assist with reducing the

number of alternatives prior to detailed evaluation. Section 3 of this document, which discusses procedures for developing alternative strategies for detailed evaluation, assists in the screening of the alternatives regarding effectiveness, costs, and reduction of the number of alternatives.

The NCP and RI/FS guidance requires that remedy selection for a site be accomplished by detailed evaluation of alternatives against nine criteria. The suggested alternative strategies development procedures in Section 3 and the review procedures of Section 4 were designed to consider these criteria. The review procedures of Section 4 assist in addressing specific concerns relevant to the criteria for the indoor air pathway.

CERCLA and the NCP require a periodic review of remedial actions, at least every five years after initiation, for so long as hazardous substances, pollutants, or contaminants that do not allow unrestricted use remain at the site. Section 5 provides procedures that may be of use in conduct of such reviews for the indoor air mitigation efforts at a site as well as for effectiveness reviews that may be desirable following implementation of the mitigation.

REFERENCE FOR SECTION 1

EPA88 Guidance for Conducting Remedial Investigations and Feasibility Studies under CERCLA. EPA/540/G-89/004, OSWER Directive 9355.3-01. October 1988.

EPA92 National Oil and Hazardous Pollution Contingency Plan (The NCP). Publication 9200.2-14. NTIS PB92-963261. January 1992.

SECTION 2 MITIGATION TECHNIQUES

The techniques described in this document are provided as options that may assist in the development of mitigation strategies for the indoor air impacts at CERCLA sites. These techniques may be considered as supplement to state-of-the-art source control technologies, such as soil gas extraction wells, ground water pumping systems, etc.

The mitigation techniques presented are intended to address indoor air contaminants that migrate into a building from external sources. The primary transport mechanisms for indoor air impacts on proximate structures are ambient air (to include wind driven), soil gas intrusion, and ground water migration. Development of the mitigation strategy may be influenced by the transport mechanism.

The techniques are presented in one of two broad classes: technical measures; and institutional controls. Technical measures are mitigation techniques that employ engineering principles to reduce the indoor air impact. Institutional controls are mitigation techniques based on legal principles that reduce indoor air impacts by restricting the use of the affected property. Institutional controls are used to supplement engineering controls at the site.

2.1 CONTAMINANT PATHWAYS

Air emissions from the site, both gaseous and particulate, may be carried by ambient air to the impacted structure. The rate at which ambient air infiltrates a building is a function of several factors including wind speed, indoor-outdoor temperature differences, height of the building, and leaks in the building envelope. The use of vented equipment, such as mechanical ventilation systems, bathroom and kitchen fans, or oil and gas furnaces and fireplaces also affects infiltration. Typical buildings ex-

change between about 0.5 and 1.0 building volumes of air per hour. "Tight" buildings may have exchange rates as low as 0.25 building volumes per hour.

Volatile pollutants in migrating soil gases, such as from a landfill or groundwater plume, may also enter the ambient air at the ground surface near the structure and enter with the ambient air. While generally these concentrations would be expected to be low, they may be high enough to be of concern in cases where the pollutant is highly toxic.

Contaminated soil gases can enter a structure through any opening in that part of the building shell directly above or in contact with the ground. This includes, among others, cracks in below-grade floors and walls, porous structural components such as cinder blocks, sumps, and openings where utilities such as electrical, water, or gas or oil lines enter. Soil gases may diffuse into the building or be drawn in due to reduced pressure in the building. Air pressures below ambient can develop in the lower stories of a building as a result of indoor-outdoor thermal differences, the use of vented equipment, or it may be wind induced. Although these pressure differences are small, typically between 1 and 10 pascals, they can result in the building literally sucking in soil gases through cracks and openings.

If the water table is near the ground surface, direct intrusion of contaminated groundwater into below-grade parts of the structure is possible. Contamination may be from a migrating plume of contaminated groundwater or from groundwater contact with contaminated soil near the structure.

Many commercial and residential buildings use wells as a water supply. If these wells intersect the contaminated groundwater, the pollutants may be volatilized from indoor uses of that water. Typical residential activities which may result in volatilization of the pollutants are showering, cooking, and clothes washing.

2.2 TECHNICAL MEASURES

Much of the technical information contained in this Section is based on techniques found to be applicable to radon reduction in indoor air. Although that information was intended only for the mitigation of radon, the principles of operation and the primary entry routes are theoretically comparable to those for other gases. They are applicable; therefore, to the development of mitigation strategies for the indoor air impacts related to CERCLA sites.

The following technical measures are offered as available options to be considered when developing a mitigation strategy. The list is not exhaustive. It is likely that combinations of, or adaptations to, the listed techniques may produce the most benefit. This technology is in its infancy and innovation and ingenuity are often required to obtain the desired results. The technical measures discussed in this Section are:

- Source Removal
- Prevention of Soil Gas Entry
- Removal from Indoor Air
- New Construction Techniques

2.2.1 Source Removal

Source removal requires substantial or complete removal of the source generating the indoor air contaminant. This technique may involve the removal of contaminated soil and the back fill of uncontaminated soil or the removal of the remote source of the contamination. Applicability is limited to situations in which a significant amount of the source can be isolated and removed. Obviously, the cost-effectiveness and feasibility of this alternative should be evaluated.

Building materials may be contaminated by settled particulate matter or groundwater intrusion. In some cases, removal of these contaminants

from the building materials, or removal of the contaminated building materials that have been identified as causing elevated indoor contaminant levels, may be indicated. Applicability is limited to situations in which the contaminant source has been isolated and can be effectively remediated or removed. The cost-effectiveness and feasibility of this alternative can restrict its application.

2.2.2 Prevention of Soil Gas Entry

Soil permeability is a function of the void to solid ratio of soil. The voids between the solids will be occupied by either liquids or gases. Pressure and/or concentration differentials between adjacent voids cause the liquids or gases to migrate. This migration is a primary pathway for contaminant transport from the source to an impacted building.

In order for contaminated soil gas to have a deleterious effect on the indoor air of an impacted building, the soil gas must enter the building envelope. The driving forces influencing the entry of soil gas are somewhat complex. Examples of the driving forces influencing soil gas entry are weather, building design, indoor/outdoor temperature differences, and mechanical depressurization (e.g., exhaust fans). Figure 2-1 illustrates some of the driving forces acting on a residential building which may induce a negative pressure differential between the building and the soil. A checklist of factors that may contribute to the driving force of soil gas entry are listed in Table 2-1. In general, soil gas entry can be prevented or controlled through:

- Sealing soil gas entry routes,
- Ventilating the soil or crawl space beneath the building to divert soil gas away from the building substructure, and
- Adjusting the pressure inside the building to reduce or eliminate the driving force for soil gas entry.

2.2.2.1 Sealing of Soil Gas Entry Routes

Soil gas may enter a building via numerous pathways or entry routes. Soil gas entry routes can be categorized by their relative potential for soil gas influx. Major entry routes allow virtually unrestricted flow of soil gas into the building. Examples of major entry routes include exposed soil, sumps, floor drains, French drains, and uncapped hollow block walls. Minor entry routes include slab/wall cracks and block wall pore openings. Although minor entry routes have a lower potential for soil gas influx than major entry routes, they are considered a significant pathway for soil gas migration into a building (EPA88). Figure 2-2 diagrams potential entry routes into a building. Table 2-2 lists possible soil gas entry routes into a residential building. These can be used to assist with a visual inspection to identify entry routes. Visual inspection alone is not likely to locate all entry routes. Some actual examples of locating and sealing entry routes are described in the Appendix (Case examples 3 and 5).

In order to effectively seal an entry route, a gas-tight physical barrier must be placed in the pathway between the source and the interior space. Numerous sealants, caulks, and membranes are commercially available to seal entry routes. When properly selected and applied, these products effectively seal entry routes. One-part gun grade or flowable urethane caulks are most effective for cement surfaces and when permanent sealing is being considered. Silicon caulks are not as effective on cement surfaces and are easily removed. Gas-tight sealing of minor entry routes and inaccessible major entry routes is often impractical or impossible. In some cases it is possible to partially seal or close entry routes. Closure of an entry route will restrict gas flow but not necessarily provide a gas-tight seal. Periodic inspection of the installed seals will help to ensure the seals or closures effectively minimize soil gas entry.

The complexity of the sealing effort is dependent on the level of mitigation required and is site specific. Some form of entry route sealing is recommended for almost all mitigation techniques. Sealing is often used in conjunction with other remediation techniques. The sealing of potential

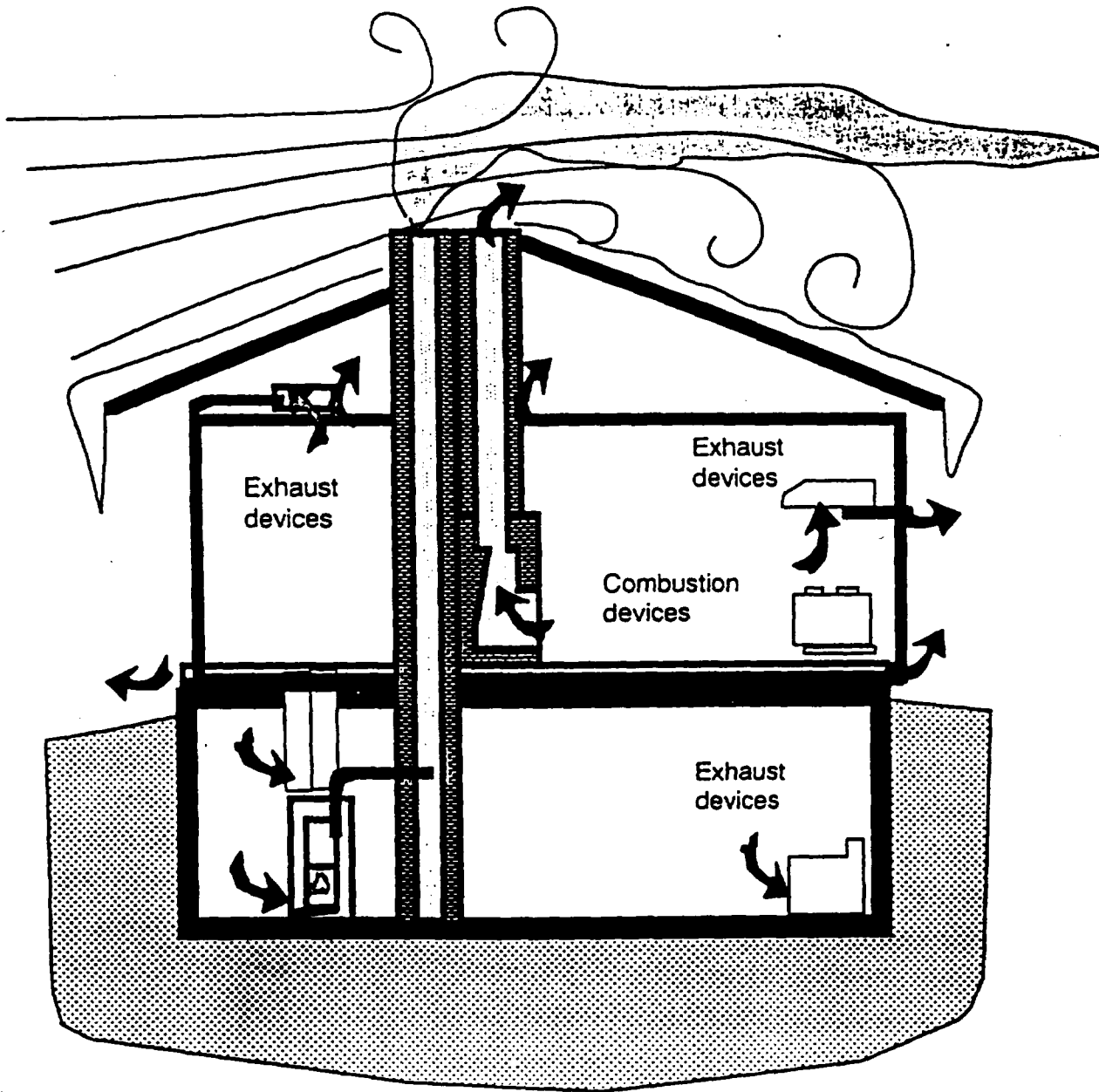

Source: EPA91A

Figure 2-1. Negative Pressure Sources in a Typical House

Table 2-1. Factors Contributing to the Driving Force for Soil Gas Entry*

WEATHER FACTORS	
	Cold temperatures outdoors create a buoyant force on the inside warm air and depressurize lower levels.
	High winds contribute to depressurizing the building.
DESIGN FACTORS	
	Openings through the building shell above the neutral plane contribute to exfiltration of warm air, potentially increasing soil gas infiltration. Such openings can include: spaces between windows and window frames; uncaulked gaps between window frames and the exterior house finish; attic soffit vents (must remain open); open dampers in chimneys and flues; concealed openings through walls and roof (e.g., openings around electrical junction boxes and switch plates in the walls, seams between strips of siding).
	Openings through the floors and ceilings inside the house can potentially increase warm air exfiltration and soil gas infiltration. Internal airflow bypasses include: open stairwells; utility and duct chases; laundry chutes; cavity inside frame walls; attic access doors; recessed ceiling lights; hollow block walls; HVAC ducts.
OCCUPANT ACTIVITIES AND APPLIANCE USE	
	Appliance which draw combustion air from inside and exhaust to the outside such as: fireplaces; wood or coal stoves; central gas or oil furnaces and fuel fired water heaters located indoors.
	Fans which exhaust indoor air outdoors such as: window or portable fans in exhaust mode; clothes dryer exhausts; kitchen, bath, and attic fans.
	HVAC systems where the return ducts, by design or through leaks, preferentially withdraws air from, and depressurizes, the lower floors of the structure.
	Open doors in the stairwells between floors.
	Open doors or windows only on downwind side of building.

* - Adapted from EPA88

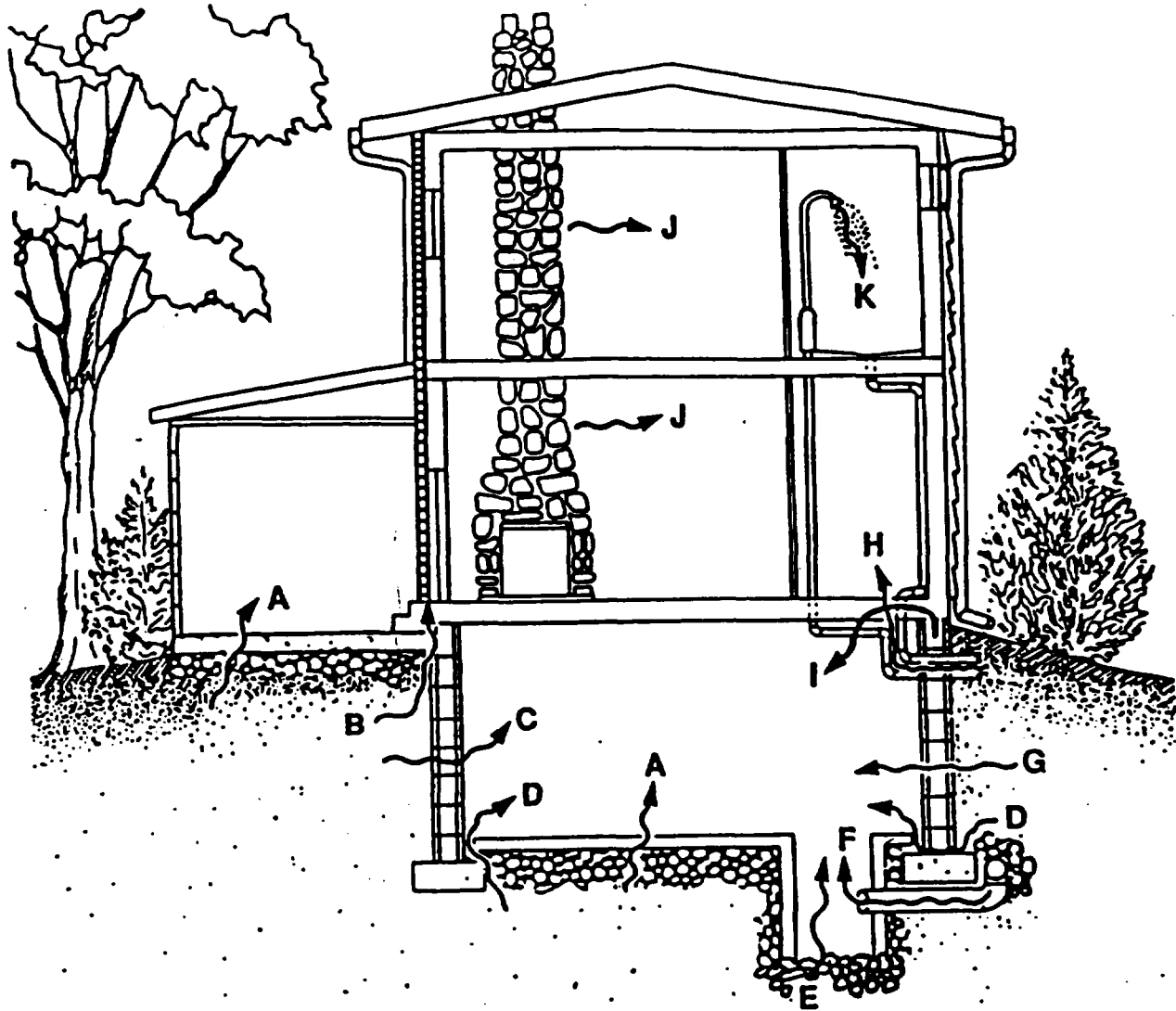

- A. Cracks in concrete slabs
- B. Spaces behind brick veneer walls that rest on uncapped hollow-block foundation
- C. Pores and cracks in concrete blocks
- D. Floor-wall joints
- E. Exposed soil, as in a sump
- F. Weeping (drain) tile, if drained to open sump
- G. Mortar joints
- H. Loose fitting pipe penetrations
- I. Open tops of block walls
- J. Openings around fireplace and chimney supports
- K. Water (from some wells)

Source: EPA87

Figure 2-2. Major Soil Gas Entry Routes

Table 2-2. Possible Soil Gas Entry Routes into a Typical House

ENTRY ROUTES ASSOCIATED WITH THE FOUNDATION WALL	
	Holes in foundation walls around utility penetrations through the wall (e.g., water, sewer, electrical, fuel oil)
	Any other holes in the walls, such as defects in individual blocks in hollow-block walls, drilled holes for electrical junction boxes, chinks between fieldstones in this type wall
	Any location in which the wall consists of exposed soil or underlying rock
	With hollow-block walls, unclosed voids in the top course, unclosed voids in blocks around windows and door penetrations, pores in the face of the blocks, cracks through the blocks or along mortar joints (including hairline cracks). Applies to exterior walls and interior walls which penetrate the floor slab and rest on footings beneath the slab.
	With poured concrete foundation walls, settling cracks in the concrete, pressure cracks, and pouring flaws
	In split-level houses with slab-on-grade or partial basement section adjoining lower basement, joint between the lower basement wall and the floor slab of the higher level
	Any block or stone structure built into a wall, such as fireplace or fireplace support, where a cavity can serve as hidden conduit for soil gas entry
ENTRY ROUTES ASSOCIATED WITH CONCRETE FLOORS	
	Any exposed soil or rock in which concrete is absent, such as sometimes found in fruit cellars, attached greenhouses, and earthen floor basements
	Any holes in the slab exposing soil, such as from wooden forms or posts that have been removed or rotted
	Sumps which have exposed soil at the bottom and/or drain tiles opening into the sump (drain tiles can serve as soil gas collectors and route it into the house via the sump)
	Floor drains, if untrapped or no water in trap or cleanout plug missing, and if drain connects to the soil (e.g., connects to perforated drain tiles or to septic system).
	Openings through the slab around utility penetrations
	Cold joints in the slab
	Settling Cracks in the slab

Table 2-2. (Cont'd)

	Wall/floor joint around the perimeter where the slab meets the foundation wall. The crack can be 1 to 2 in. wide in houses with French drains. Wall/floor joints for interior walls which penetrate the slab can also be entry points.
	Any hollow objects which penetrate the slab, such as: hollow metal load-bearing posts; hollow concrete blocks (e.g., serving as base for furnace or water tank); hollow pipes (e.g., serving as legs for fuel oil tank)
ENTRY ROUTES ASSOCIATED WITH DECOUPLED CRAWL SPACE HOUSES	
	Seams and openings in the subflooring between the crawlspace and the living area (e.g., openings around utility penetrations)
	If a central forced-air HVAC is situated in the crawl space, leaks in the low-pressure return ducting which permits crawl space air to leak into the house circulating air

entry routes can be a simple quick fix to reduce the infiltration of contaminated soil gas or a major effort to form a gas-tight membrane over exposed soil in the basement of a building. In most cases, in order to significantly reduce the infiltration of soil gas, sealing must be supplemented with another mitigation technique (EPA88).

Foundation and/or soil settling can cause a building's sub-structure to move or shift. These dynamics often cause sealed entry routes to reopen over time and to introduce new entry routes. Therefore, periodic inspections of the sealed openings and condition of the unsealed substructure are critical aspects of ensuring the long-term effectiveness of this mitigation technique. Table 2-3 identifies some of the advantages and disadvantages of using sealing entry routes as the primary mitigation technique.

The application of this mitigation strategy is, in theory, relatively simple. The first step is to identify major and minor soil gas entry routes, which can be difficult in many cases. Once these are identified, the mitigator should compare possible alternatives and select the most appropriate and cost effective products to achieve the desired results.

Table 2-3 SEALING OF ENTRY ROUTES

ADVANTAGES	DISADVANTAGES
Applicable to all buildings	Extensive surface preparation may be required
Relatively simple to implement	Requires periodic inspections to ensure airtight seals over time
30 to 90 percent reduction in contaminant level possible if all major entry routes sealed	Difficult to seal all entry routes. Access to floor/wall joints is difficult and can be labor intensive
Sealants recommended for specific applications are readily available	

Detailed preparation of the substrate will often be required to form an effective gas-tight seal. This preparation can be time consuming and expensive. The manufacturer's installation instructions should be followed during application of the selected product.

After installation, periodic inspection of the sealed areas should be conducted to identify damage from physical contact, degradation, or water. The inspection should include damaged seals, seals that may have reopened, and new cracks that have opened due to movement and shifting of the substructure caused by normal settling of the foundation over the life of the building. Identified new openings and damaged seals should be repaired.

The cost of materials for sealing soil gas entry routes can range from \$100 to \$500 depending on the extent of the sealing effort (EPA88). Labor costs could cause significant increases when extensive surface preparation or elaborate membrane systems are required (EPA88).

A list of manufacturers is provided in Table 2-4. A list of commercially available products is provided in Table 2-5.

Table 2-4. Sealant Manufacturers/Suppliers

Manufacturer	Mailing Address	City	State	Zip	Phone
Acme Chemicals & Insulation Co.	166 Chapel Street	New Haven	CT	06513	(213) 562-2171
American Cyanamid	One Cyanamid Plaza	Wayne	NJ	07470	(201) 831-2000
Dow Chemical Co.	2020-T Dow Center	Midland	MI	48640	(517) 636-1000
Dow Corning Corp.	P.O. Box 0994	Midland	MI	48640	1-800-447-4700
Essex Chemical Corp.	1401 Broad St.	Clifton	NJ	07015	(201) 773-6300
Fomo Products, Inc.	1090 Jacoby Rd. P.O. Box 4261	Akron	OH	44321	(216) 753-4585
Geocel Corp.	Box 398	Elkhart	IN	46515	(219) 264-0645
Halltech, Inc.	465 Coronation Drive	West Hill	Ontario	M1E 2K2	(416) 284-6111
Insta-Foam Products, Inc.	1500 Cedarwood Drive	Joliet	IL	60435	1-800-435-9359
Sika Chemical Corp.	P.O. Box 297T	Lyndhurst	NJ	07071	(201) 933-8800
Thiokol Corp.	Box 8296 930 Lower Ferry	Trenton	NJ	08650	(609) 396-4001
Tremco	10701 Shaker Blvd.	Cleveland	OH	44104	(216) 292-5000
Universal Foam systems, Inc.	Box 548 60001 S. Penn.	Cudahy	WI	53110	(414) 744-6066
Bostik Construction Products	P.O. Box 8	Hunting Dan Valley	PA	19008	(800) 523-6530
Ventron Corp.	150-T Andover St.	Danvers	MA	01923	(617)744-3100

Note: Inclusion of a manufacturer on this list should not be construed as an endorsement by EPA of the manufacturer or the manufacturer's products. This table is not represented as a complete listing of suitable manufacturers. This table is intended only as a partial listing of some vendors known to be marketing sealants.

Table 2-5. Sealant Information

Sealant Name	Sealant type	Manufacturer
SMALL CRACKS		
Fomofill	Bead caulk	Fomo Products
Geocel Construction 1200	Caulk, silicone	Geocel
Geocel SPEC 3000	Caulk, urethane	Geocel
Sikatop	Nonshrink grout w/ binder	Sika Chemical
Silastic	Caulk, silicone	Wright/Dow Corning
Intra-Seal Kit, I-S 550	Bead caulk	Insta-Foam
Handi-Foam, Model I-160	Bead caulk	Fomo Products
LARGE CRACKS		
Versi-foam 1	2-part urethane foams	Universal Foam
Versi-foam 15	2-part urethane foams	Universal Foam
Froth Pak FP-180	2-part urethane foams	Insta-Foam
Dow Corning Fire Stop Foam Kit # 2001	2-part silicone liquid	Insta-Foam
Insta-Seal Kit, I-S 550	Bead caulk	Insta-Foam
Handi-Foam, Model I-160	Bead caulk	Fomo Products
Froth-Pak Kit FP-9.5	2-part spray foam	Insta-Foam
Fomofill	Bead caulk	Fomo Products
Geocel Construction 2000	Caulk, silicone	Geocel
Temco THC-900	Flowable urethane, two-part	Geocel
Zonolite 3300	Spray foam	W.R. Grace
Polycel One	Expanding foam, ure- thane	W.R. Grace

Table 2-5 (Cont'd)

Sealant Name	Sealant type	Manufacturer
PORES		
Thiokol WD-6	Alkylpolsulfide copolymer (0.102 cm thick)	Thiokol
Rock Coat 82-3	PVC copolymer solution	Halltech
Resitron II	2-part furan	Ventron
HydrEpoxy 300	2-part water based epoxy	Acme Chemical
Aerospray 70	One component	American Cyanamid
Acryl 60	Surface bonding cement	Standard Dry Wall Products
Trocal, etc.	Sheeting; polymer, Almylar, PVC, polyethylene	Dynamit Nobel Of America, Inc.
DESIGN OPENINGS		
Versi-foam 1 & 15	2-part urethane foam	Universal Foam
Froth Pak FP-180	2-part urethane foam	Insta-Foam
Froth Pak Kit FP-9.5	2-part spray foam	Insta-Foam
Velkem	Flowable urethane	
Zonolite 3300	Spray foam	W.R. Grace

Note: Inclusion of a sealant in this table should not be construed as an endorsement by EPA of this sealant or its manufacturer. This table is not represented as a complete listing of suitable products or manufacturers. This table is intended only as a partial listing of some of the sealants known to be commercially available.

2.2.2.2 Diverting Soil Gas Away from Foundation

Active and passive systems to effectively divert soil gases away from a building's foundation have been developed. These systems fall into one of three general categories: the system may mechanically introduce a negative pressure on sub-floor soil and vent contaminated gas away from the foundation; the system may mechanically introduce a positive pressure on the sub-floor soil to dilute the contaminated soil gas before it enters the building (not recommended); the system may afford the soil gas a controlled means to vent away from the house without active mechanical assistance. Based on currently available information, negative pressure soil ventilation has been a consistently effective method of mitigation for radon reduction (EPA88).

In the pressurization mode, outdoor air is forced into the sub-floor region to create a "pressure bubble" under the building to force soil gases away from the foundation. This technique can cause re-entry of sub-slab contaminants into the building through unsealed entry routes. EPA has experienced pesticide re-entry when using positive pressurization.

In the depressurization mode, a negative pressure is mechanically applied to the sub-floor region which causes soil gases to be evacuated before they can enter the building (Figure 2-3). Gas movement through unsealed entry routes should be toward the gas collection system when the system is properly operating.

Particular care should be used when installing any of the active depressurization systems discussed below due to the potential to cause backdrafting of combustion equipment. If significant amounts of indoor air are drawn into the depressurization system through unsealed entry routes, the relative negative pressure created in the building may draw combustion products from fireplaces and fired furnaces into the structure. Diagnostic testing should be performed after installation to assess this possibility.

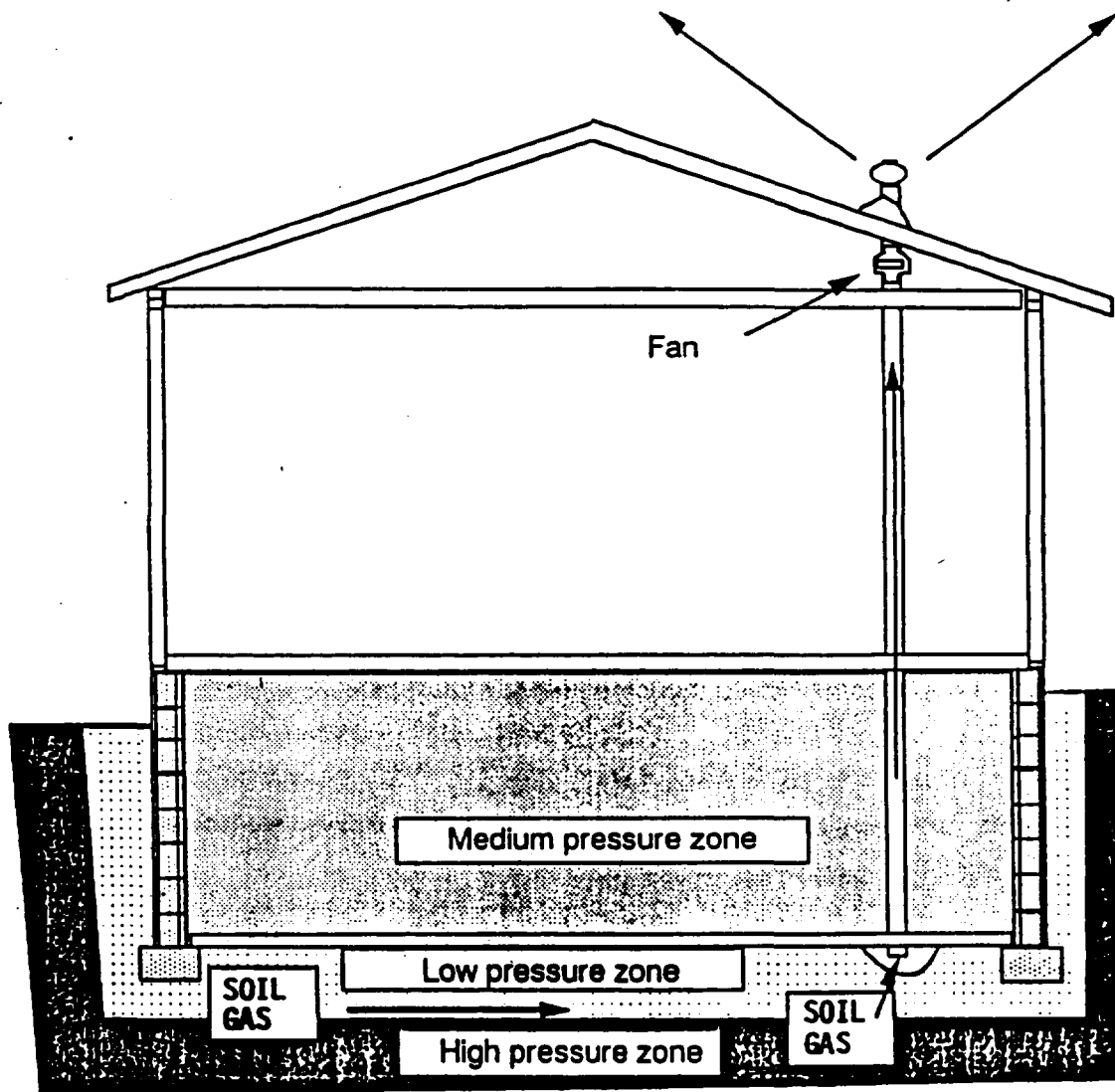

Source: EPA91A

Figure 2-3. Theory of Operation of a Sub-slab Depressurization System

Gases from the system vents should be exhausted above the building roofline in a location that will minimize the potential for the exhausted gases to reenter the building. Generally, the gases are exhausted directly to the atmosphere. In a few cases, control devices, such as activated carbon, have been used to capture the pollutants in the system exhaust. These exhaust emissions may be included as part of the pathway in calculating risks to determine if controls are actually warranted.

Passive venting of contaminated soil gas may be accomplished in some instances. Soil gases are vented from the sub-floor region as a result of the buoyancy caused by temperature and pressure differentials across the building envelope.

The types of soil ventilation techniques that have been used include:

- Drain Tile Soil Ventilation (Active)
- Sub-Slab Ventilation (Active)
- Block Wall Ventilation (Active)
- Isolation and Ventilation of Sources (Active and Passive)
- Passive Ventilation

2.2.2.2.1 Drain Tile Soil Ventilation

Drain tiles are frequently used to control water intrusion into a building. They are placed during construction and can either circle the perimeter of the building on the interior or exterior of the foundation wall. Interior (or sub-floor) drain tiles can be placed either around the perimeter adjacent to footings or in a pattern under the floor. Water collected in the drain tiles is routed to a remote above-grade discharge, a dry well, or to a sump for mechanical pumping to an above grade discharge.

Drain tiles provide a convenient in-place network that enables the suction or pressure field to be applied over a relatively wide area. Active drain tile ventilation may be applied to buildings having drain tile loops which surround most or all of the perimeter of the foundation or buildings with open sumps with connected drain tiles (Figure 2-4). This

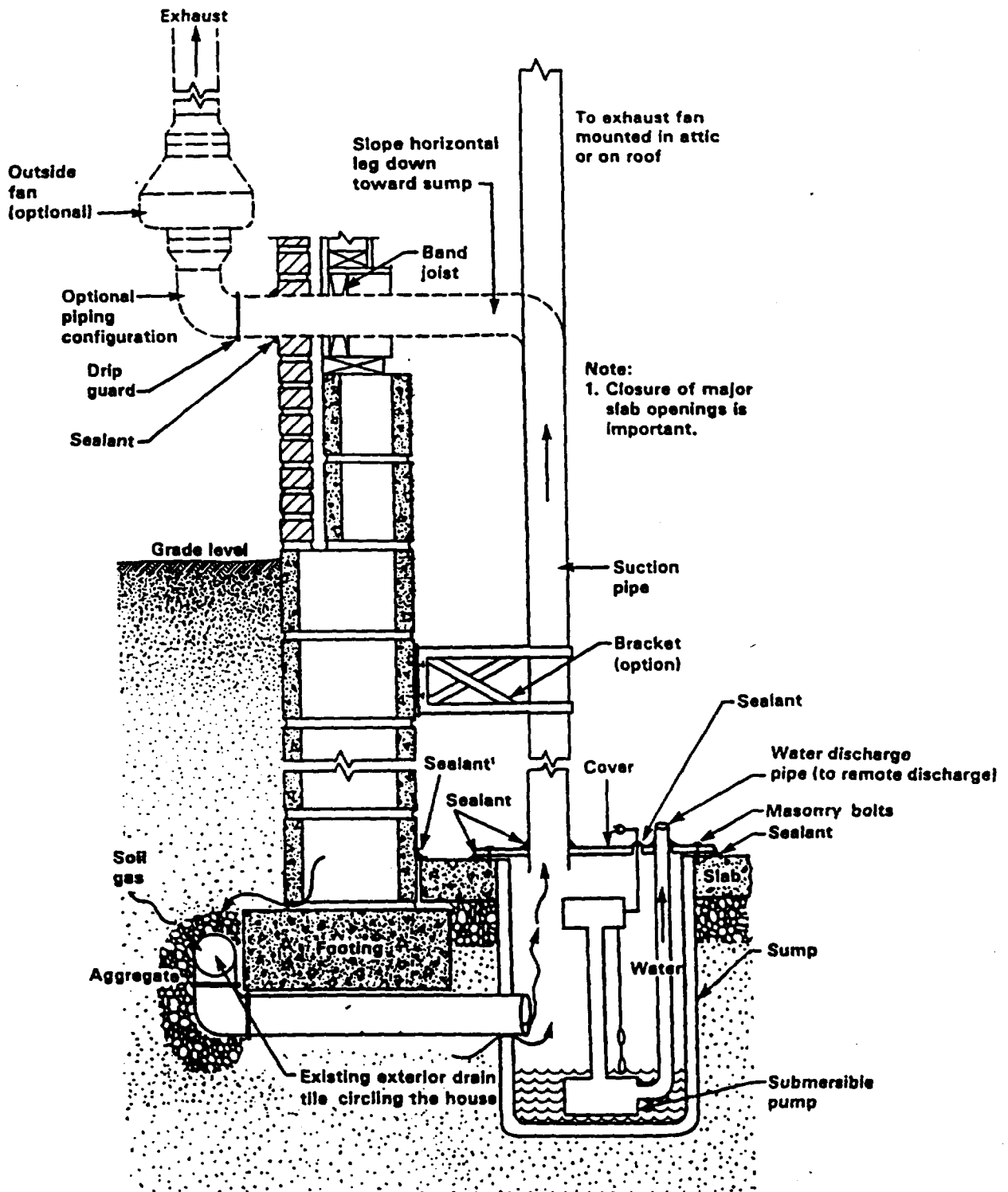

Source: EPA87

Figure 2-4. Drain Tile Ventilation Where Tile Drains to Sump

technique has demonstrated a high degree of success in the mitigation of radon. Reductions as high as 99 percent have been achieved (EPA88). Assuming an intact unclogged drain tile network, a marked reduction in soil gas contaminant entry may be achieved using this mitigation technique.

Ventilation of drain tile systems should receive first consideration if it is in place and soil ventilation appears appropriate. Because a considerable amount of outside air may be drawn into the suction system, in some cases an adequate lowering of sub-slab pressure may not be practically achieved. Diagnostic testing is required to assess the practicality of this technique. However, alternative mitigation techniques are likely to be more cost effective than retrofitting a drain tile system around an existing structure.

The design and installation costs for a drain tile ventilation system (not including drain tile installation) for a single family residential building might cost between \$700 and \$2,500 (EPA88). This cost estimate is dependent on the depth of the drain tile network, the presence of a sump, the location of the exhaust fan, the length of piping, and the number of vertical connections to the drain tile required to achieve adequate ventilation of the sub-slab region. Existing building finishes, performance requirements, the level of diagnostic testing performed, and the specific construction characteristics of the building will influence the cost. Table 2-6 identifies some advantages and disadvantages of using drain tile soil ventilation as the primary mitigation technique.

2.2.2.2.2 Sub-slab Ventilation (Active)

In the application of this technique, either a suction or pressure field may be applied to the gravel fill beneath a concrete slab. The field is mechanically induced by installing a venting system with an attached fan. Sub-slab depressurization (SSD) has been the most successful and widely used radon reduction technique in slab-on-grade and basement houses. It has been proven capable of achieving very high radon reductions in single-family residential buildings. Its applicability to larger struc-

tures has been tested in schools and proven effective. It has also been used successfully in controlling VOC intrusions for

Table 2-6 DRAIN TILE SOIL VENTILATION (Active)

ADVANTAGES	DISADVANTAGES
Applies ventilation at major entry routes. Effective on hollow block wall construction	Drain tile loops difficult to access
Provides an in-place network for pressure field	Requires intact, undamaged drain tile loop for optimum performance
90 percent or higher reduction in contaminant level possible	Major entry routes should be sealed
Can be installed where tiles drain to an internal sump	Outside air flow into system can reduce performance
	Flooding may reduce performance
	Energy penalty for fan use
	Fan maintenance required

detached houses, townhouse clusters, and a school (see the Appendix). Assuming good permeability of the sub-slab region and sufficient ventilation points to create a pressure field beneath the entire slab, it is likely that a marked reduction in soil gas contaminant entry will be achieved using this mitigation technique.

In the depressurization (suction) mode, soil gases are drawn from the sub-slab region and exhausted via a network of pipes to the outside of the building (Figures 2-5 and 2-6). The intent of the system is to create a continuous low-pressure region beneath the entire slab sufficient to prevent soil gas from entering the building. Systems operating in suction mode rather than in pressure mode have a greater likelihood of success. Results have been mixed with pressure systems and there is evidence that pressurization can result in an increase of soil gas influx and resuspension of contaminants through some entry routes.

Note:

1. Closing of major slab openings (e.g., major settling cracks, utility penetrations, gaps at the wall/floor joint) is important.

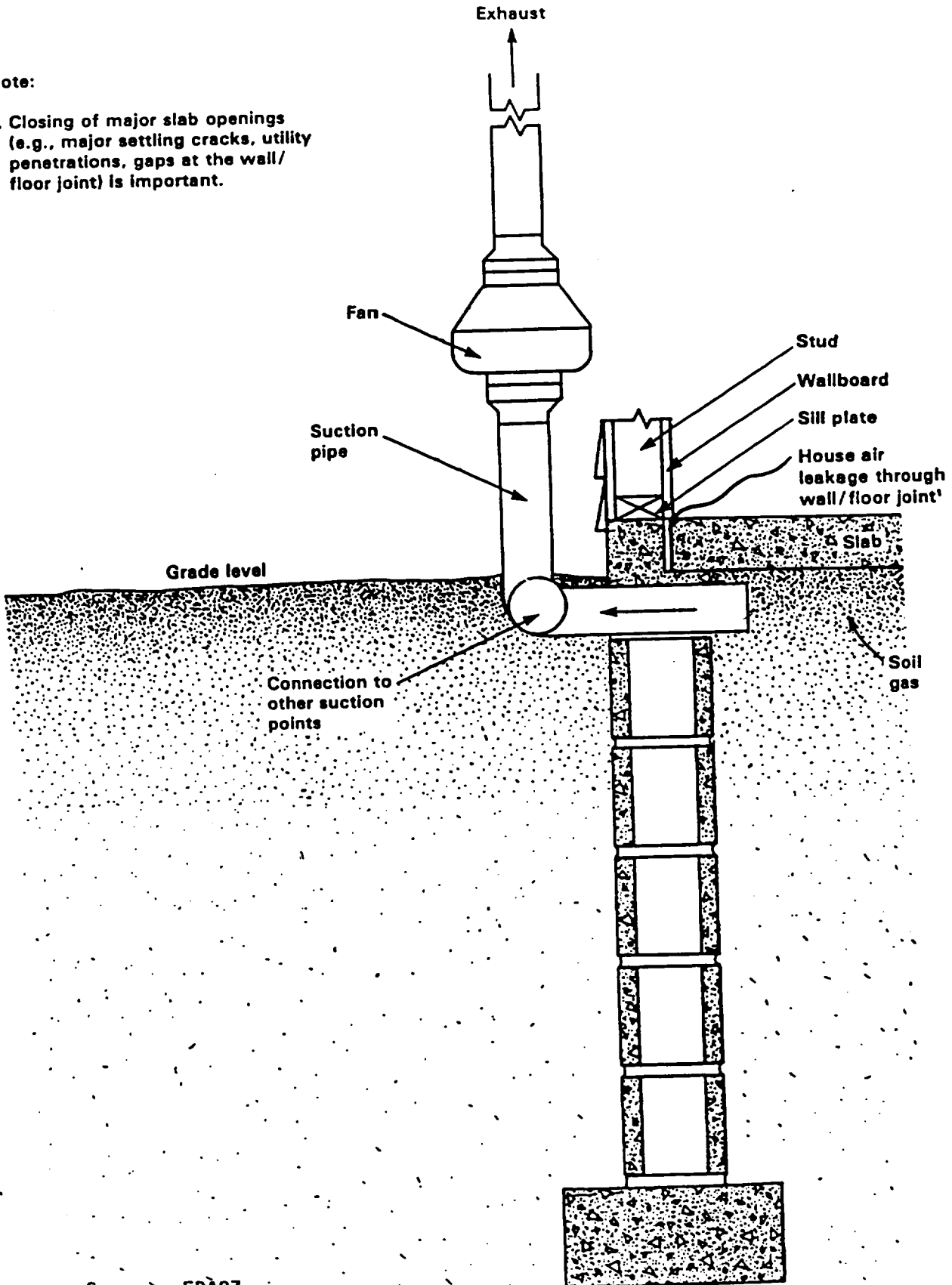

Source: EPA87

Figure 2-5. Sub-slab Suction Using Pipes Inserted Through Foundation Wall

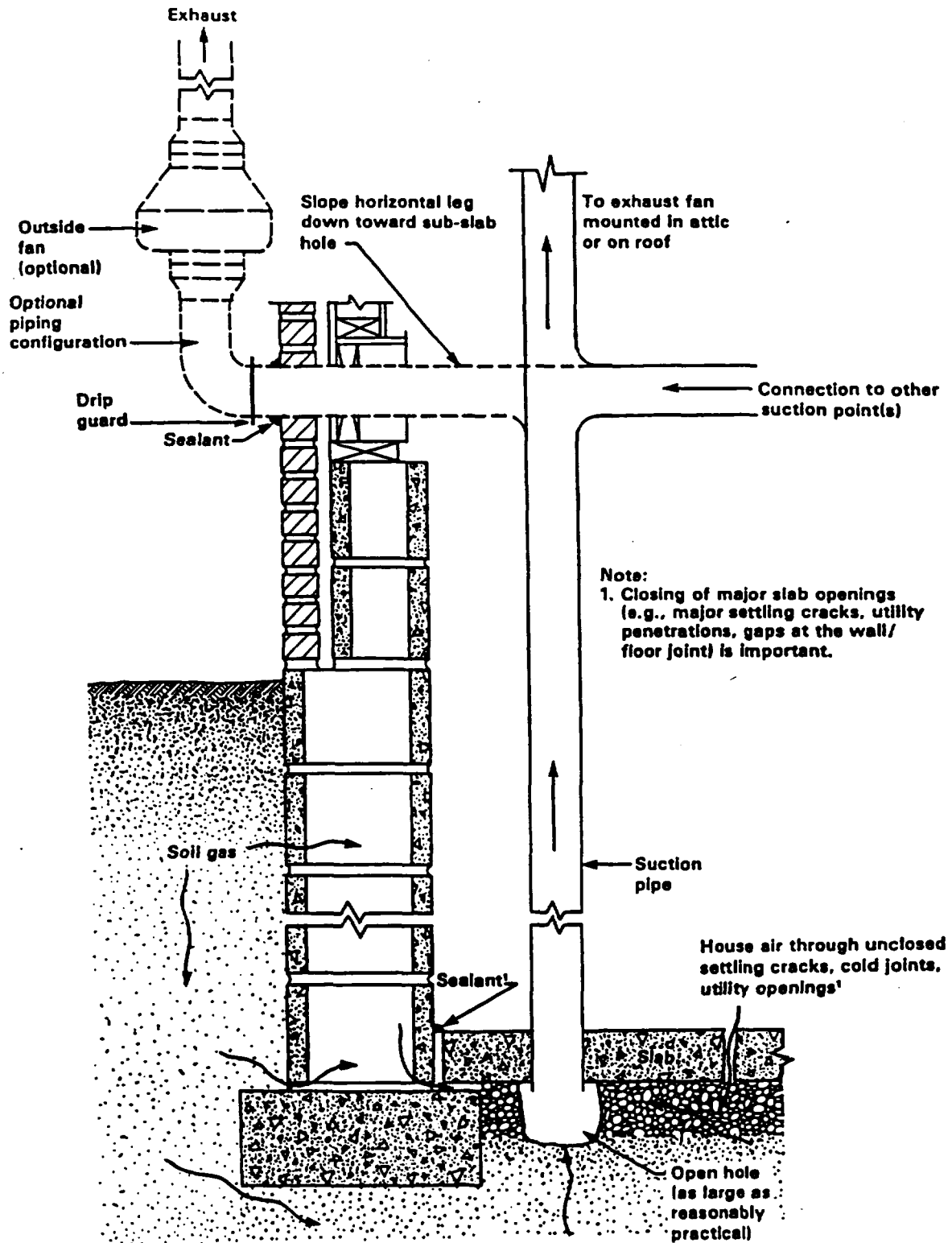

Source: EPA87

Figure 2-6. Sub-slab Suction Using Pipes Inserted Down Through Slab

Typical systems installed use 3 to 6 inch diameter PVC pipes (size depends on length of pipe run, number of bends, etc.) for gas collection and venting. Exhaust fans are generally sized to produce about 0.5 to 1 inch water column vacuum at the point the suction pipe enters the floor slab. In-line 250 cubic feet per minute fans are frequently used. However, the actual fan selected for a given installation will depend on the sub-slab permeability, the air leakage into the system, the piping pressure losses, among other considerations.

This mitigation technique may be applied to any building or any area of a building that has an impermeable floor slab. However, the permeability of the sub-slab region is a significant factor in the effectiveness of this mitigation technique. Good permeability will permit the ventilation effects of a limited number of suction points to extend effectively under the entire slab. Slabs having limited permeability under all or part of the sub-slab region will require a greater number of ventilation points.

A variation of SSD is referred to as sub-membrane depressurization (SMD). SMD has been successful in reducing radon levels in a number of houses constructed over crawl spaces. A polyethylene or rubber membrane is laid over the soil floor and sealed to the crawl space walls and internal piers. Suction is applied to the soil underneath the membrane and the soil gas is exhausted to the outdoors.

The design and installation costs for a sub-slab ventilation system for a single-family residential building might cost between \$900 and \$2,500 (EPA88). This cost estimate is influenced by the presence of a permeable sub-slab region, the location of the exhaust fan, the length of piping, and the number of vertical ventilation points required to achieve adequate ventilation of the sub-slab region. Existing interior finishes, performance requirements, the level of diagnostic testing performed, and the specific construction characteristics of the building will influence the cost of design and installation. Table 2-7 list some advantages and disadvantages of this technique.

Table 2-7 SUB-SLAB SOIL VENTILATION (Active)

ADVANTAGES	DISADVANTAGES
Can be applied to any building with a concrete floor slab under all or part of the building	Soil permeability unknown prior to diagnostic testing
Extensive installation performance documentation available	Low permeability sub-slab regions require numerous ventilation points
90 percent or higher reduction in contaminant level	Exhaust of high concentration of contaminated air when in suction mode
Sub-slab region likely to consist of gravel layer	Major entry routes should be sealed
	Energy penalty related to fan operation and exhaust of room air through unsealed entry routes
	Fan maintenance required

2.2.2.2.3 Block Wall Ventilation (Active)

Hollow block walls have been identified as potential major soil gas entry routes. The voids within hollow block walls can serve as a conduit for soil gas to enter a building through mortar joints, pores, and other wall penetrations (Figure 2-7). Mitigators have used hollow block walls as an in-place network to apply a negative pressure to remove soil gas from the void or apply a positive pressure to keep soil gas from entering the void.

Block wall ventilation may only be applied to buildings with hollow block walls. Buildings where satisfactory mitigation is not achieved with a sub-slab suction system may have supplemental ventilation points installed in the wall cavity. This mitigation technique when used in conjunction with other mitigation techniques can be very effective.

The design and installation costs for a block wall ventilation system for a single family residential building might cost between \$300 and \$2,500

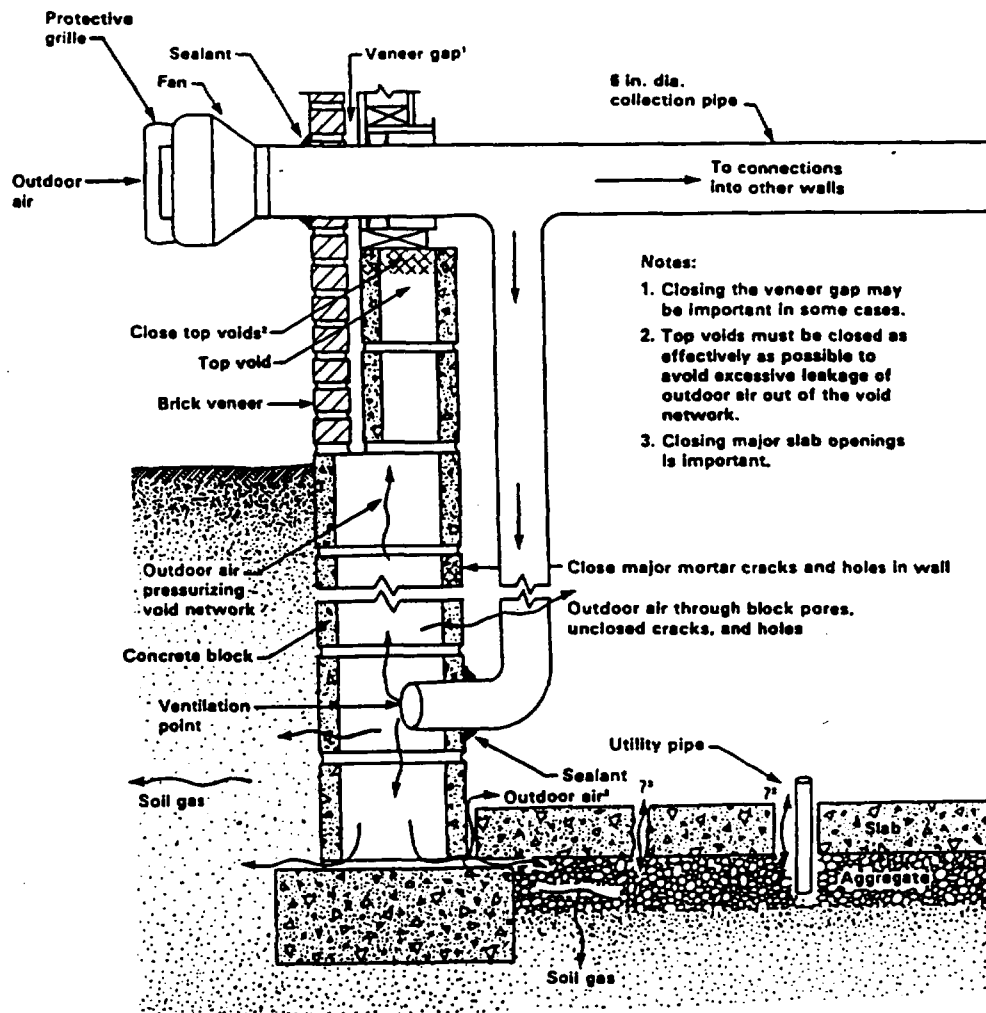

Source: EPA87

Figure 2-7. Wall Ventilation with Individual Pressurization Point

(EPA88). This cost estimate is dependent on the accessibility of major entry routes requiring closure, the location of the exhaust fan, the length of piping, and the number of ventilation points required to achieve adequate ventilation of the wall cavity. Existing interior finishes, performance requirements, the level of diagnostic testing performed, and the specific construction characteristics of the building will influence the cost of design and installation. Some of the advantages and disadvantages of block wall ventilation are given in Table 2-8.

Table 2-8 BLOCK WALL VENTILATION (Active)

ADVANTAGES	DISADVANTAGES
Can be applied to any building with hollow concrete block walls	May require numerous ventilation points
Wall cavity provides an in-place network to apply ventilation over a wide area	Energy penalty related to fan operation and exhaust of room air through unsealed entry routes
	Exhaust of high concentration of contaminated air when in suction mode
	Major entry routes should be sealed
	Percent reduction in contaminant level difficult to estimate
	Fan maintenance required

2.2.2.2.4 Isolation and Active Ventilation of Areas Sources

Where a large soil gas entry route (or a collection of entry routes) exists, it may be economical to cover (or enclose) the large route, and to ventilate the enclosure with a fan. Thus, the source of the soil gas is isolated, and the soil gas can not enter the living space. Examples of such an isolation/ventilation approach would be:

- Covering an earth-floored crawl space or basement with an air-tight plastic sheet ("liner"), and actively ventilating the space between the liner and the soil (for example, using a network of perforated piping under the liner).

- Building an airtight false wall over an existing foundation wall which is a soil gas source, and ventilating the space between the false wall and the foundation wall.
- Building an airtight false floor over a cracked concrete slab, and ventilating the space between the false floor and the slab.

This mitigation technique is best applied to crawl spaces with soil or gravel floors for which it is infeasible or uneconomical to use natural or forced air ventilation. This mitigation technique has been applied in conjunction with other mitigation techniques and has been fairly successful. No data are available on the effectiveness of this technique as the sole form of mitigation.

2.2.2.2.5 Passive Soil Ventilation

Theoretically, any of the fan-assisted ("active") soil ventilation approaches described in the previous sections could be attempted without the aid of a fan (that is, "passively"). With passive systems, natural phenomena are relied upon to develop the suction needed to draw the soil gas away from the entry routes into the building. Passive systems require the use of a vertical stack, connected to the ventilation piping network, that rises through the building and penetrates the roof (Figure 2-8). A natural suction is created in the stack by two phenomena: 1) the movement of wind across the top of a properly positioned vertical stack can create a negative pressure in the stack; 2) the buoyancy created when the stack (indoors) is warmer than outdoor air causing the stack to act as a pathway for soil gas to raise. Depending on the outdoor temperature and wind currents, the pressure differential created in the stack (but not under the slab which can be considerably less) of a passive system is typically on the order of several hundredths of an inch of water, considerably less than that developed by fan-assisted systems.

Passive soil ventilation may be best applied to buildings with slightly elevated levels of contaminants in the indoor air that have entered with soil gas. If properly designed, the system may be retrofitted with a fan, if required, for warm weather operation. Sub-slab permeability

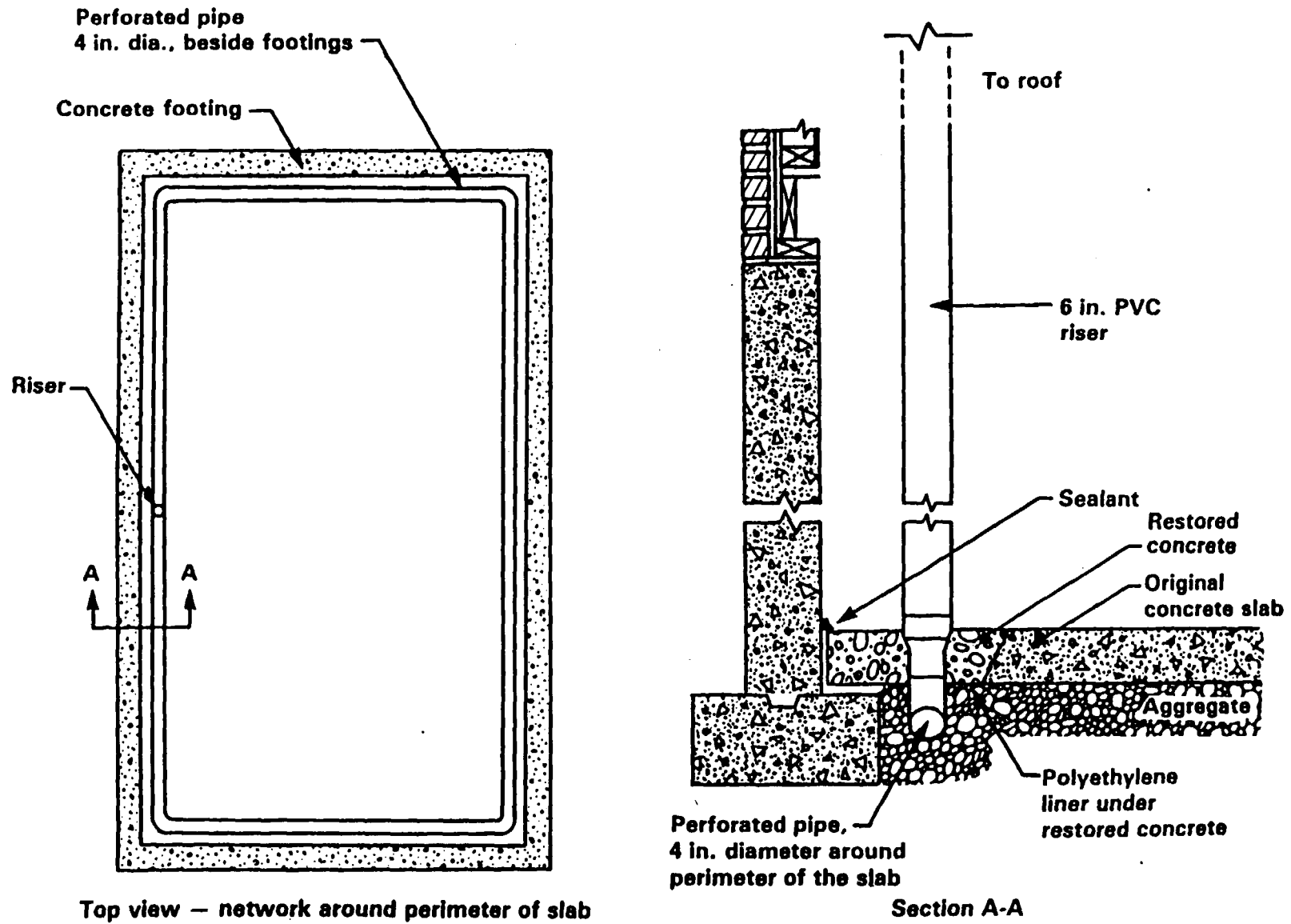

Source: EPA87

Figure 2-8. Passive Sub-slab Ventilation System

is a significant factor in the success of passive ventilation. If the permeability is good enough to allow soil gas ventilation with the slight suction created passively, the system has a much better opportunity for success. Advantages and disadvantages are summarized in Table 2.9.

2.2.3 Removal from Indoor Air

Once a contaminant has been introduced into the indoor air of a building, the control options are limited to dilution to control the indoor concentrations or removal by mechanical air cleaners.

Table 2-9 SUB-SLAB SOIL VENTILATION (Passive)

ADVANTAGES	DISADVANTAGES
Can be applied to any building with a concrete floor slab under all or part of the building	Soil permeability unknown prior to diagnostic testing
Fan maintenance is not required	Low permeability sub-slab regions require numerous ventilation points
70 to 90 percent reduction in contaminant level possible in some cases	Likely not to work in warm weather without fan assist
Sub-slab region likely to consist of gravel layer	Major entry routes should be sealed

2.2.3.1 Ventilation/Dilution

Contaminants infiltrating the sub-structure and entering a building can be controlled by diluting the indoor concentrations with uncontaminated outdoor air. The objective of this mitigation technique is to increase the building's air exchange rate. Typical air exchange rates in U.S. homes are approximately 0.5 to 1.0 air changes per hour (ACH). The air exchange rate is a function of mechanical air exchange, and infiltration/exfiltration rates. Infiltration/exfiltration rates are influenced by weather conditions and air tightness of the building. Air exchange in residential construction is typically achieved by local exhaust ventilation, and air exfiltration/infiltration. In other types of construction, mechanical ventilation systems may draw or force outdoor air into the building.

The stack effect phenomena accounts for much of the passive air exchange in residential buildings. The upward buoyant force of warm air creates, relative to outdoors, a positive pressure region in the upper portions of the house and a negative pressure region in the lower portions of the house. Between these pressure regions lies a neutral plane at which no detectable pressure differential exists. As indoor air rises, it leaks out (exfiltrates) through penetrations in the building envelope on the upper levels of the building (above the neutral plane). To compensate for the exfiltration, outdoor air and soil gases leak into the lower levels of the building (below the neutral plane). Only about 1 to 5 percent of the outdoor infiltration air is composed of soil gases (EPA88).

House ventilation can be used as a mitigative technique by following one or more of the following techniques:

- Increase ventilation using natural ventilation
- Mechanically induce air movement and air exchange without energy recovery
- Mechanically induce air movement and air exchange with energy recovery

2.2.3.1.1 Increase Ventilation using Natural Ventilation

This method is based on keeping windows and doors open to the maximum extent practical. It can generally be used in any building with operable windows and doors. The principle governing this technique is that contaminated indoor air is diluted with uncontaminated outdoor air. This technique will obviously only be effective if outdoor contaminant concentrations are below acceptable levels. Ninety percent reductions have been observed in the mitigation of indoor radon using this method.

Due to the obvious problems with this method (e.g., security, heating and cooling costs), it is unlikely to be used as part of any strategy for mitigating the impacts addressed in this document.

2.2.3.1.2 Mechanical Outdoor Air Introduction without Energy Recovery

The mechanical introduction of outdoor air can act to dilute indoor contaminant concentrations and pressurize the building to reduce the influx of soil gas through entry routes. Most existing residential buildings are not designed with the capacity to introduce outdoor air into the building. It is possible to reconfigure an existing HVAC system to introduce outdoor air. Alterations to an existing HVAC system should only be made by qualified HVAC contractors. Outdoor air may also be introduced through a separate system, such as a window mounted fan or a ducted outdoor air fan. The fan should discharge into the building below the neutral plane. Fans must not be operated in the exhaust mode as this depressurizes the building and can increase soil gas intrusion.

Several important considerations should be addressed prior to selecting mechanical outdoor air introduction with an existing HVAC system:

1. The existing fan and motor must be sized correctly to provide a sufficient volume of outdoor air to dilute indoor contaminants to a satisfactory level. The addition of a second fan, a two speed fan, or a variable speed fan may be necessary to attain the desired results.
2. The heating and cooling capacities of the system must be sized correctly to handle the increased heating, cooling, and moisture loads caused by the introduction of outdoor air. Humidification may be required in some locations.
3. Increased filtration may be required to ensure dust, pollen, microbes, etc. are removed from the outdoor air being introduced into the system.
4. An energy analysis is recommended to determine the energy penalty associated with the introduction of outdoor air.

2.2.3.1.3 Mechanical Air Exchange with Energy Recovery

By using an energy recovery device to pre-condition the outdoor air, the energy penalty for mechanical outdoor air introduction will be reduced. Energy recovery devices, heat recovery ventilators (HRVs), or air-to-air

heat exchangers, are devices which use fans to accomplish a controlled degree of forced-air ventilation, while recovering some of the energy from the exhaust air stream (Figure 2-9). HRVs typically include two fans, one blowing a controlled amount of outdoor air into the building, and a second blowing an equal amount of indoor air to the outside. The incoming and outgoing air streams pass near each other in the core of the exchanger. In cold weather, the warmer indoor air being exhausted heats the incoming air. In hot weather, the cooler indoor air cools the incoming air. Thus, some of the energy used to condition indoor air is recovered. Several types of HRVs are commercially available. Three basic types of HRVs are presently available: 1) fixed-plate; 2) rotary wheel; and 3) heat transfer fluid pipes.

HRVs have been installed for radon mitigation. Their effectiveness as a control device is questionable. Success has been achieved in single-family homes only when installed to treat basements. A 50 to 75 percent reduction in radon concentrations has been reported (EPA88). Whole-house residential HRV treatment is not usually recommended unless the house is extremely tight (i.e., hourly air exchange rates of 0.25 or less) because of the limited air handling capacity of appropriate units. The principle reduction mechanism acting when using HRVs is dilution. As previously discussed, two reduction mechanisms are acting when mechanical outdoor air introduction is implemented. First, the driving force drawing soil gas into the building is reduced by facilitating the introduction of outdoor air below the neutral plane to compensate for exfiltration above the neutral plane. Second, soil gases that do enter the building are diluted by the increased influx of outdoor air. By comparison, the advantages of the first mechanism are virtually lost when using HRVs. HRVs typically provide no net supply of outdoor air below the neutral plane to compensate for the exfiltration above the neutral plane.

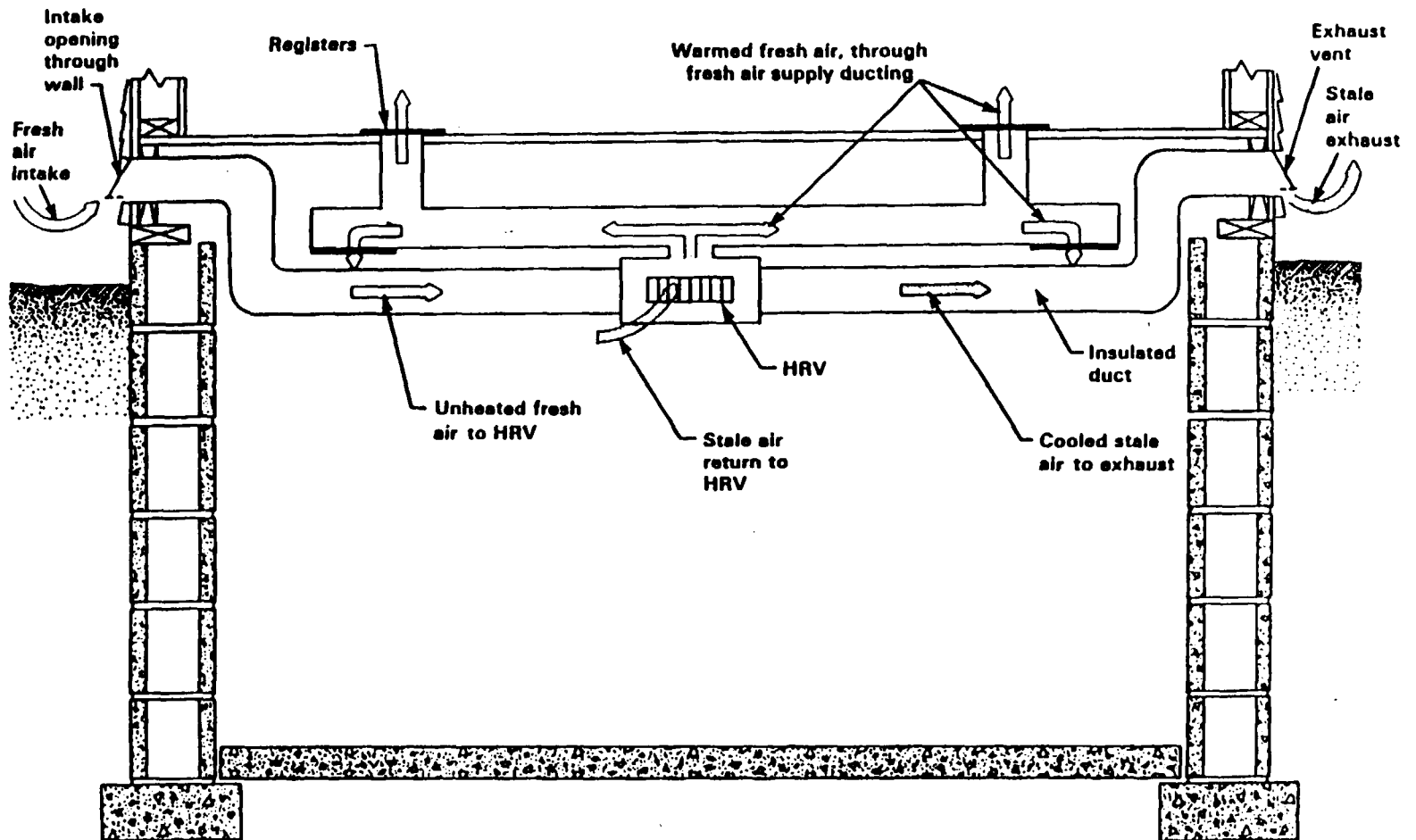

Note: Air flows are labeled for cold weather, where cold outdoor air is being warmed in the HRV. In hot weather, hot outdoor air would be cooled and dehumidified.

Source: EPA 87

Figure 2-9. Possible Configuration for a Fully Ducted HRV

As with other outdoor air introduction techniques, several important factors should be addressed when considering the installation of an HRV:

- The heating and cooling capacities of the existing HVAC system may be unable to condition the increased volume of outdoor air.
- Increased levels of dust, pollen, microbes, etc. are likely due to the increased volume of outdoor air.
- Depending on the climate, an energy penalty may be realized due to the introduction of increased volumes of outdoor air.

The relative impact of each will be reduced by a factor determined by the efficiency of the HRV selected.

The design and installation of an HRV might cost between \$1,000 and \$3,000. The installed cost is a function of the efficiency of the HRV and the operating air flow volume. Factors influencing the cost of design and installation are the accessibility of major entry routes requiring closure, and the retrofit of existing HVAC components. Existing building finishes, performance requirements, the level of diagnostic testing performed, and the specific construction characteristics of the building will influence the cost of design and installation.

Depending on the local climate, the HRV efficiency, and the volume of air exchanged by the HRV, a significant energy penalty can be experienced. Therefore, an operating cost for the operation of the HRV fan and increased energy costs for heating and cooling should be estimated and included in the mitigation plan.

2.2.3.2 Indoor Air Cleaning (EPA90)

Air cleaners are devices that attempt to remove particulate or gaseous pollutants from the indoor air. Typically, residential furnace filters are installed in prepackaged blower units and are the simplest form of air filtration to remove particles. This basic filtration system may be upgraded by installing more efficient filters that trap smaller pollutants or by adding additional air cleaning devices such as portable air cleaners.

Air cleaners generally rely on filtration or ionization to remove particles from the air. The use of air cleaning to remove pollutants from the air in residential applications is in its infancy.

There are three general types of air cleaners to remove particles presently available in the market: mechanical filters; electronic air cleaners; and ion generators. Mechanical filters may be installed in buildings with central heating and or air conditioning or may be used in portable devices.

There are two major types of mechanical air filters: flat or panel filters, and pleated or extended surface filters. Flat or panel filters consist of either a low packing density of coarse glass fibers, animal hair, vegetable fibers or synthetic fibers which are often tactified to increase the holding capability and adhere to particulate materials. Flat filters may efficiently collect large particles, but remove only a small percentage of respirable sized particulate (RSP). Flat filters may also be made of "electret" media, consisting of a permanently-charged plastic film or fiber. Particles in the air are attracted to the charged material.

Pleated or extended surface filters generally attain greater efficiency for capture of RSP than flat filters. Their greater surface area allows the use of smaller fibers and an increase in packing density of the filter without a large drop in air flow.

Electronic air cleaners use an electric field to trap particles. Like mechanical filters, they may be installed in buildings with central HVAC systems or may be portable units with fans. Electronic air cleaners are usually electrostatic precipitators or charged-media filters. In electrostatic precipitators, particles are collected on a series of flat plates. In charged-media filter devices, which are less common, the particles are collected on the fibers of a filter. In most electrostatic precipitators and some charged-media filters, the particles are deliberately ionized (charged) before the collection process, resulting in a higher collection efficiency. Ion generators also use static charges to remove

particles from the air. These devices come in portable units only. They act by charging particles in a room, so they are attracted to walls, floors, tabletops, draperies, occupants, etc. In some cases, these devices contain a collector to attract charged particles back to the unit. Note that the latter two types of devices may produce ozone, either as a by-product of use or intentionally. Because ozone is a lung irritant, consideration must be given to the potential risks of replacing one type of pollutant with another.

Some newer systems on the market, referred to as hybrid devices, contain two or more of the particle removal devices discussed above. For example, one or more types of mechanical filters may be combined with an electrostatic precipitator or an ion generator.

The performance of air cleaners in removing particles from indoor air depends not only on the air flow rate through the cleaner and the efficiency of its particles capture mechanism, but also on factors such as: the mass of the particles entering the device, the characteristics of the particles (e.g., their size), the degradation rate of the efficiency of the capture mechanism caused by loading, filter by-pass, and ventilation effectiveness.

There are at least three standard methods by which particle removal efficiency can be assessed: American Society of Heating, Refrigerating, and Air-Conditioning Engineers (ASHRAE) Standard 52-76 weight arrestance test, ASHRAE Standard 52-76 atmospheric dust spot test, and the dioctylphthalate (DOP) method in military standard 282. The weight arrestance test is only used to evaluate low efficiency filters designed to remove the largest and heaviest particles. It is of limited value in assessing the removal of respirable particles. The dust spot test is used to rate medium efficiency filters which can remove some respirable sized particles. The efficiency rating is determined using a complex mixture of dusts and is not a size specific rating. For example, EPA tests (EPA90) of a filter with an ASHRAE rating of 95 percent found only 50 to 60 percent of particles in the 0.1 to 1 μm size range. Military standard 282 is used only for high

efficiency (i.e., rating above about 98 percent) filters. The test measures the percentage removal of 0.3 μm particles of DOP.

Removal of gaseous pollutants requires the use of a sorbent material. As mentioned earlier, removal of gaseous pollutants has been applied in industrial and manufacturing processes, but the effectiveness for removal of organic compounds in residential or commercial settings is not well-documented. In general, capacities of current sorbent systems are too low to be of practical use in mitigating indoor air impacts addressed in this document.

The most frequently used process for removing such contaminants from indoor air is sorption by solid sorbents. The effectiveness is dependent upon:

- air flow rate through the sorbent material,
- concentration of the pollutants in the air stream,
- presence of other gases or vapors (e.g., water vapor),
- physical and chemical characteristics of both the pollutants and the sorbent,
- configuration of the sorbent in the device, and
- the quantity of sorbent used as well as the bed depth.

Because the rate of pollutant capture by sorbents (i.e., efficiency) decreases with the amount of pollutants captured, air cleaners for gaseous pollutants are generally rated in terms of the sorption capacity (i.e., the total amount of the chemical that can be captured) and penetration time (i.e., the amount of time before capacity is reached). Sorbents can be engineered to remove specific gaseous pollutants such as formaldehyde or classes of compounds such as volatile organic chemicals (VOCs).

Activated carbon has been used to reduce indoor concentrations of low molecular weight gases and odors to imperceptible levels. Research addressing ability to remove high concentration of pollutants, useful life, holding capacity over time, and ability to adapt to variations in type and concentration of indoor pollutants is in progress.

Special sorbents have been developed to remove specific gaseous pollutants such as formaldehyde. Many of these are "chemi-sorbents", impregnated with chemically activated materials, such as potassium permanganate or copper oxide, which will react with one or a limited number of different reactive gaseous pollutants.

2.2.4 Techniques for New Construction (EPA91A)

New buildings, developed on sites in which there is a potential for indoor air impacts from nearby CERCLA sites, may be designed using construction and mitigation techniques that will help control indoor air contaminant concentrations (Figure 2-10). As with existing buildings, control may be accomplished by preventing its entry into the building, or by reducing the indoor concentration of the contaminant once it is present in the indoor air. The principles and theories applied to existing buildings, in particular soil ventilation systems, mechanical barriers, and modified mechanical system operation are also applicable to new construction. In fact, their design and application during construction may involve less labor and financial investment.

Although these techniques have been discussed for the development of radon-resistant housing, they have not been fully demonstrated and tested. These techniques are discussed because they have a sound technical and theoretical basis and potential for success. The soil ventilation techniques have been applied and have proven to be applicable for diverting contaminated soil gas.

2.2.5.1 Soil Ventilation Systems

Soil ventilation systems may be used when the contaminant pathway is pressure-driven soil gas. Installation costs for sub-slab depressurization systems in existing houses typically range from \$900 to \$2,500. A roughed-in system that would allow for future installation, as necessary, would cost much less. Figure 2-11 illustrates how a final installation might appear so that consideration can be given during construction to locating vent pipes, etc. such that interior finishes do not have to be removed for future installation. The figure is a composite of several construction

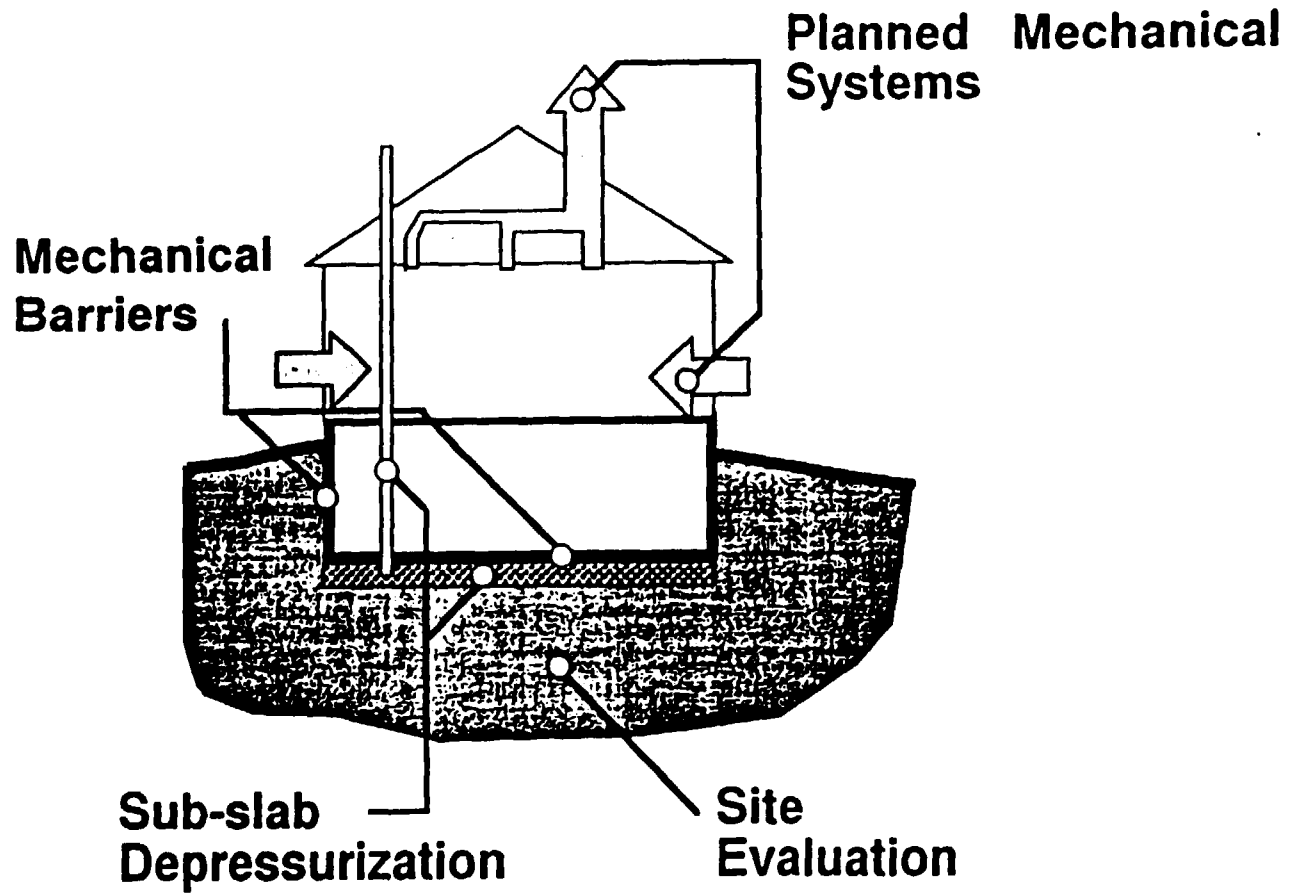

Source: EPA91A

Figure 2-10. New Construction Techniques

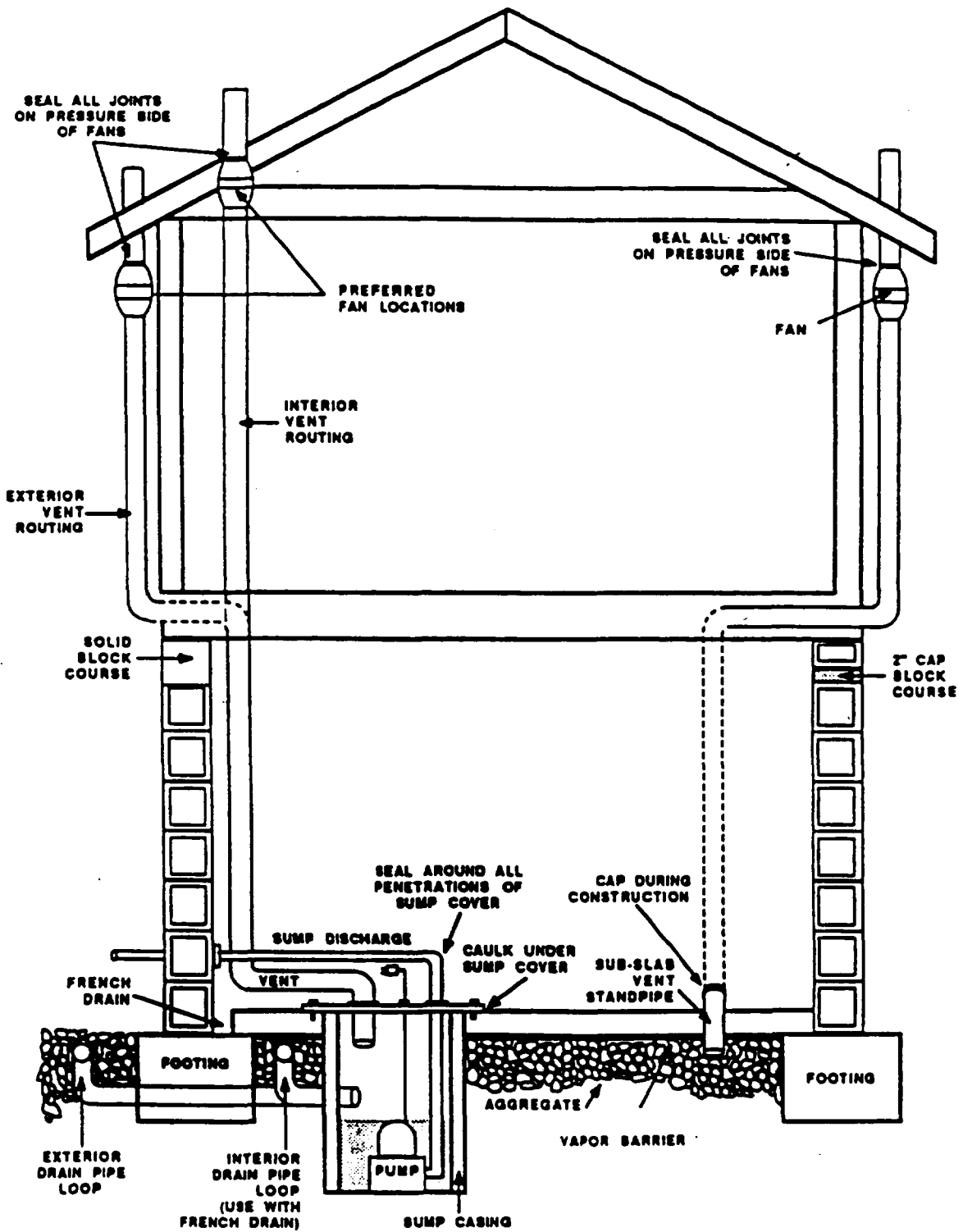

Source: EPA87

Figure 2-11. Post Construction Soil Gas Removal

techniques not likely to all be found at a specific building. A properly roughed-in system would involve a good layer of aggregate beneath the floor slab and a capped PVC pipe at a central ventilation point. A network of perforated drain tiles beneath the slab and tied to the ventilation point has also been used (Figure 2-12). If a good layer of aggregate is installed, it is not necessary to install such a network.

Passive sub-slab ventilation systems may be installed by the developer which allow for the future installation of an in-line fan. If elevated contaminant levels occur when the system is operating passively, a fan could easily be mounted on the existing passive vent stack for little more than the cost of the fan. Again, the developer should ensure a good layer of permeable aggregate is placed beneath the floor slab.

2.2.5.2 Mechanical Barriers

Theoretically, a gas-tight barrier may be placed between the soil and the building foundation to eliminate the possibility of soil gas intrusion. (Figure 2-13). The types of mechanical barriers that have been tried or suggested may be categorized as follows:

- Foundation Materials
- Coatings
- Membranes
- "Site" Barriers

Foundation materials may form a mechanical barrier. New construction typically incorporates cast-in-place concrete in the foundation. The entire foundation or merely the footings and floor slab are usually cast-in-place. Concrete masonry walls and their mortar joints can provide minor entry routes for soil gases. Solid or filled blocks should be placed as the bottom and top course of a concrete masonry wall. Dampproofing or waterproofing treatments inhibit soil gas migration and are typically required by building codes. If conventional foundation construction techniques are used, the constructor should ensure that possible entry routes are treated with a sealant after construction is completed.

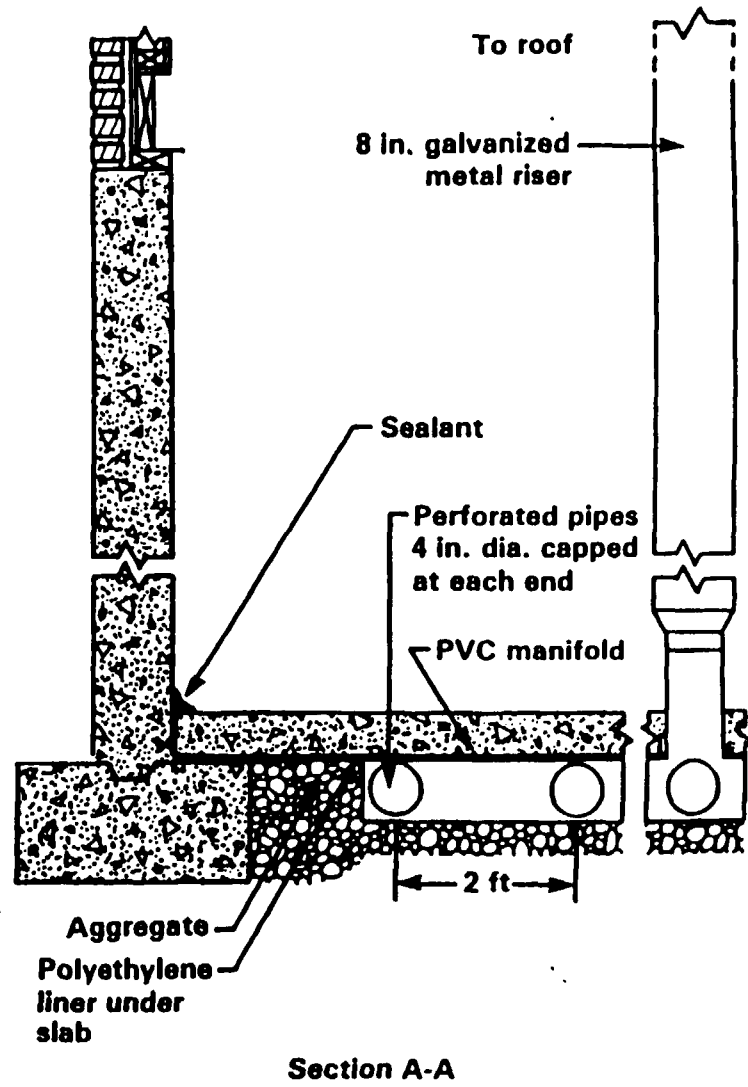
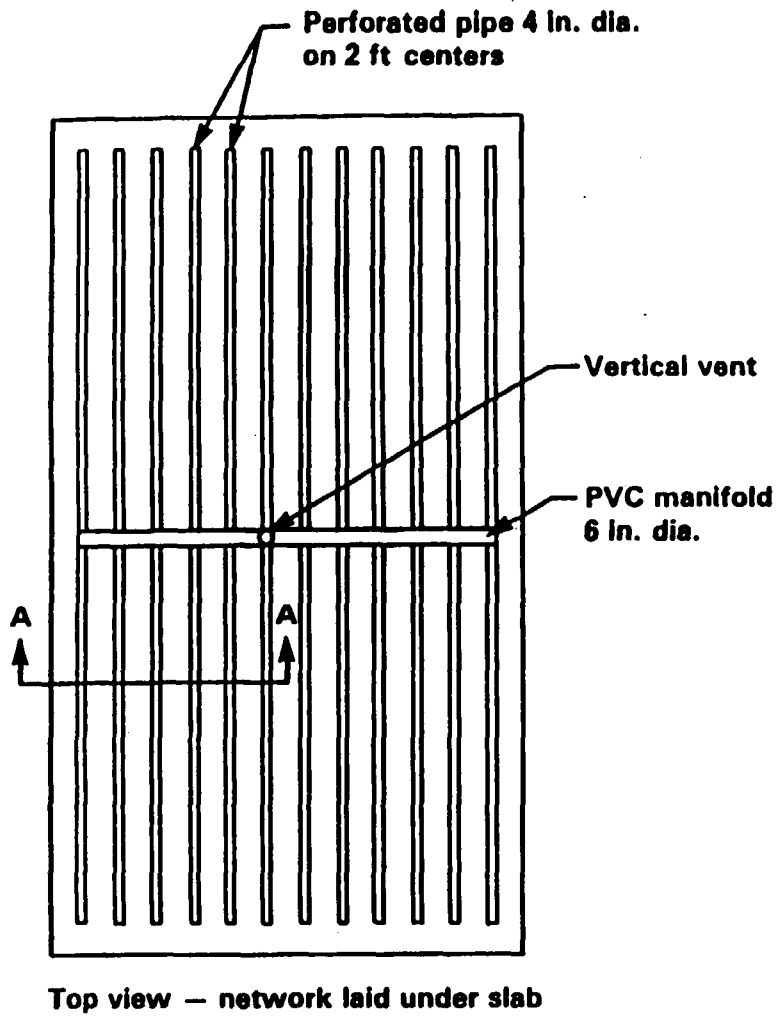

Source: EPA87

Figure 2-12. Passive Sub-slab Ventilation System

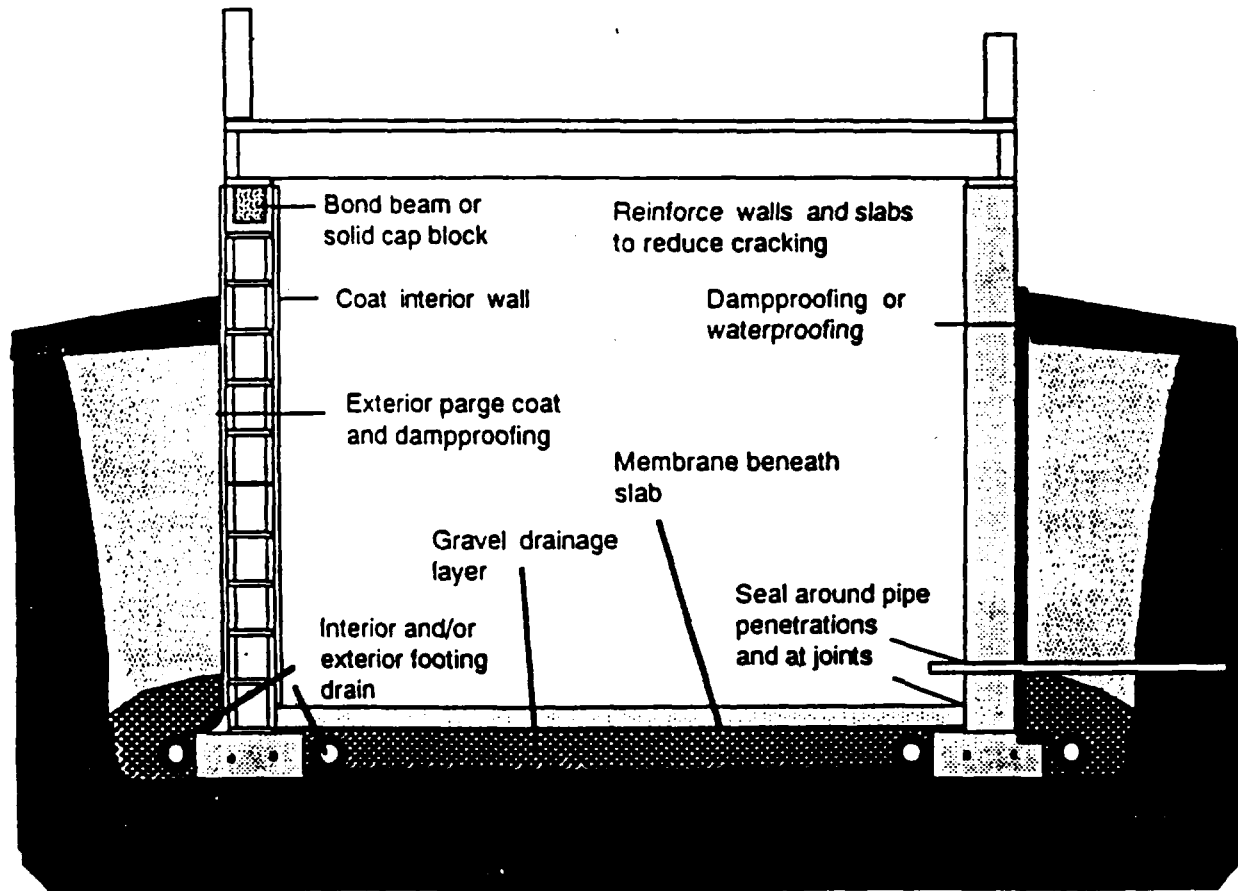

Source: EPA91A

Figure 2-13. Summary of Mechanical Barrier Approach

Membranes of plastics and rubbers that are used to control liquid water penetration and water vapor diffusion can be effective gas-tight barriers. If they are adequately sealed at the joints and penetrations and undamaged during installation, they could provide an effective soil gas barrier. The 4 to 6 mil plastic film presently being used during foundation construction as a vapor barrier has been proven to be insufficient to stop the influx of radon gas (EPA91A). More comprehensive installation measures and more durable vapor barriers may be required to control strong sources or high soil gas flow rates. Several types of membranes are commercially available:

- Polyethylene Films
- Foil faced, High Strength Bubble Pack
- Aluminum Foil over Glass Scrim Webbing
- PVC Membranes
- Ethylene Propylenediene Monomers (EPDM)

Polyethylene films have been used as a vapor barrier to prevent moisture entry from beneath the slab for several decades. Although these barriers offer a gas-tight seal when intact, it is virtually impossible to install them without puncturing or tearing them. Another issue is the stability of the polyethylene vapor barrier. Ultraviolet (UV) exposure is known to deteriorate polyethylene. Although their exposure to UV may be short lived during construction, the materials deterioration over time is not well known.

On the other hand, no evidence exists that polyethylene deteriorates with exposure to soil chemicals. High-density polyethylenes are used for storage and transport of numerous chemicals. Polyethylene is chemically stable, but may be adversely affected by aliphatic hydrocarbons (such as butane, hexane, and octane) and chlorinated solvents. Polyethylene-based membranes have been used at hazardous waste landfills, lagoons, and similar applications to control subsurface migration.

Foil faced, High Strength Bubble Pack has a high compression strength and doubles as an insulator. This material is somewhat fragile and is susceptible to puncture. Therefore, its ability to endure the construction and installation process make its applicability questionable.

A product using aluminum foil facing on two sides with an asphalt coating over a glass scrim webbing has potential but has not been tested for its resistance capability. The product will likely perform similarly to other foil faced products. It also is susceptible to puncture during installation.

PVC and EPDM membranes are very durable and have been used for mitigation of radon in existing houses. Both were originally developed as roofing membranes and can provide air-tight seals, if properly installed.

2.2.5.3 MECHANICAL SYSTEM DESIGN

Potential indoor air impacts should be addressed in the HVAC system design and operation. The HVAC system should be designed to:

- help control soil gas influx,
- allow controlled volumes of outdoor dilution air to enter the building, and
- maintain an acceptable indoor temperature and relative humidity range to the building.

Controlling soil gas influx by mechanical means may be accomplished by establishing a positive pressure on the lower (at and below grade) levels of the building. This is achieved by simply introducing a larger volume of air into the space than is exhausted from the space. That is, the total cubic feet of air supplied to the space should be greater than the total cubic feet of air exhausted from the space.

Other ventilation system features may be incorporated to reduce indoor contaminant concentrations, reduce soil gas entry, or otherwise increase the acceptability of the system. For example heat recovery ventilators

(HRVs) may be incorporated to reduce the energy penalty associated with increasing air exchange rates and combustion appliances should use outdoor air for combustion. Figure 2-14 illustrates ventilation system design aspects that may help achieve the desired results.

2.3 INSTITUTIONAL CONTROLS

In some cases technical controls may have to be supplemented by institutional controls (ICs) to limit exposure. ICs differ from technical controls in that ICs are restrictions on the use of property. ICs may be used to broadly require or prevent certain activities at or near a site or they may be a narrow, specific restriction such as restricting use of contaminated groundwater.

The material in this Section is intended to provide the reader with a general overview of the types of ICs. It is not intended as legal guidance and should not be construed as such. For legal advice, the reader should consult counsel. For legal guidance, the reader may also consult the memorandum from D. F. Coursen to H. F. Corcoran (see Reference EPA92B). Portions of that memorandum are restated here for the reader's benefit.

There are two fundamentally distinct types of ICs, which might be characterized as governmental and proprietary controls. Governmental controls involve a state or local government using its police powers to impose restrictions on citizens or sites under its jurisdiction. Proprietary controls involve property owners using their rights as owners to control the use of, or access to, their property. The two types of ICs must be discussed separately, since they differ significantly in regard to scope, reliability, and appropriate mechanisms for implementation. (EPA92B)

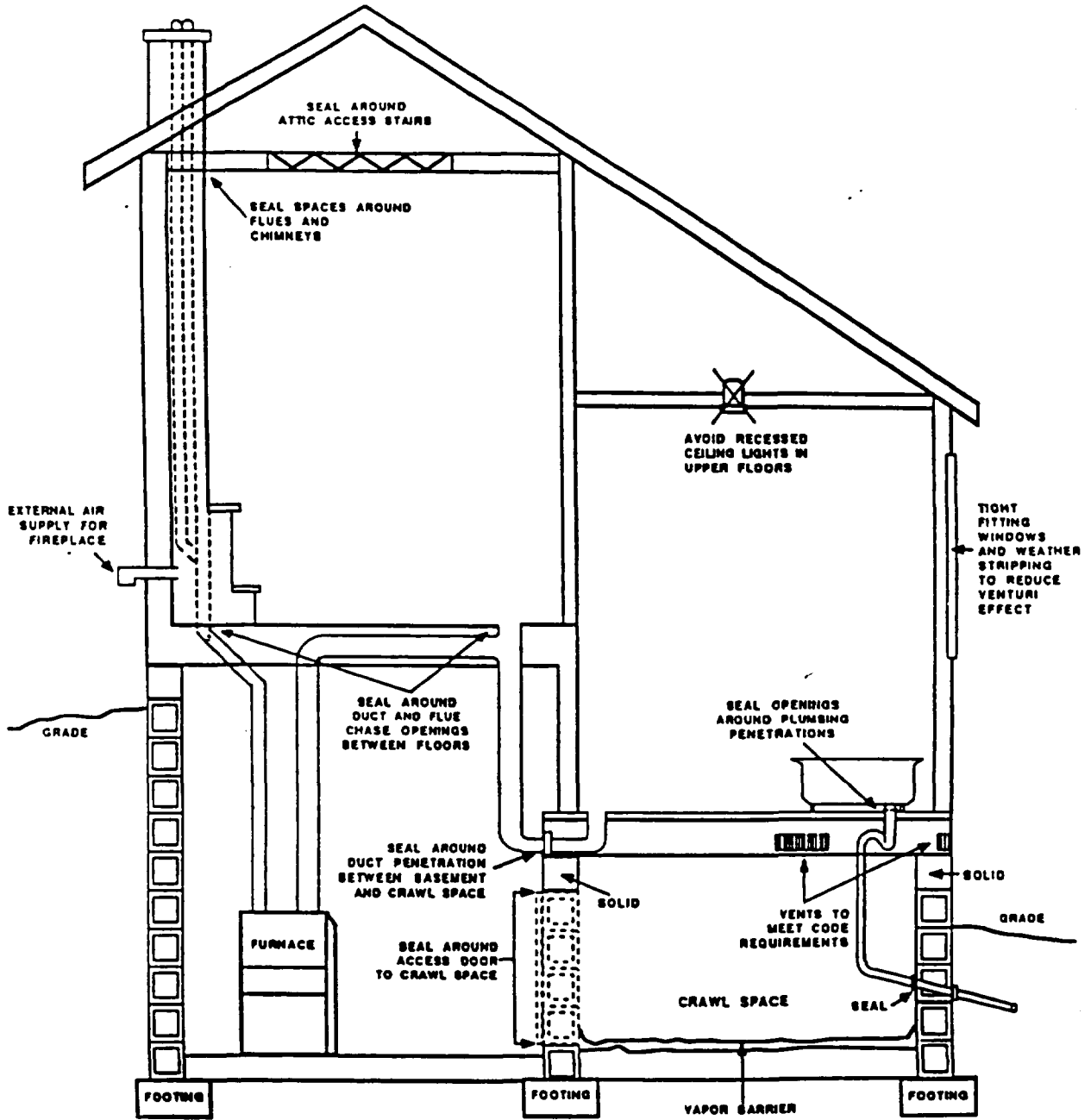

Source: EPA87

Figure 2-14. Methods to Reduce the Vacuum Effect

The National Contingency Plan (NCP) sets out EPA's expectation that ICs "shall not substitute for active response measures ... [that actually reduce, minimize, or eliminate contamination] as the sole remedy unless such measures are determined not to be practicable, based on the balancing of trade-offs among alternatives that is conducted during the selection of remedy." [40 CFR § 300.430(a)(1)(iii)(D)]. Nevertheless, where active remediation is not practicable, ICs may be "the only means available to provide for the protection of human health." [55 Federal Register at 8666, 8706 (March 8, 1990)]. However, where controls are the sole remedy "special precautions must be made to ensure that the controls are reliable." [55 Federal Register at 8706]. Controls may also be "a necessary supplement where waste is left in place as it is in most response actions." Id. (EPA92B)

The NCP does not discuss or identify the precautions needed to ensure the reliability of ICs. It does specify, however, that in appropriate cases the Agency cannot provide remedial action unless a state assures "that institutional controls implemented as part of the remedial action are in place, reliable, and will remain in place after initiation of operation and maintenance." [40 CFR § 300.510(c)(1); see also 42 U.S.C. § 9604(c)(3)]. (EPA-92B)

The use of ICs to assist with mitigation of indoor air impacts must generally be considered as supplemental to both technical measures used specifically for that purpose and to response measures selected to remediate the CERCLA site. The use of ICs for mitigation of indoor air impacts may be considered to be most applicable to situations in which site remediation will quickly eliminate or adequately reduce those impacts, in which technical measures are inadequate or not cost effective during long-term remedial actions, in which active measures are not practical for the site and/or the affected property, and in which they are a necessary supplement to other controls where waste is left in place following remediation.

"An IC may fail if it is inadequately designed or not fully and effectively implemented or if full and effective implementation cannot be maintained for the desired time period." (EPA92B). It is critical to give careful consideration, early in the planning process, to the development of ICs that will meet the needs at the site and to determine what measures can be taken to maximize their effectiveness. It is strongly recommended that

Regional counsel be consulted as soon as it appears that ICs may be needed. Failure to do so may negatively impact the range of ICs that may be considered or the timeliness with which they may be implemented. Assessing effectiveness of ICs is discussed in Section 3.3.2.

2.3.1 Governmental ICs

As the NCP points out, institutional controls typically are unlikely to be implemented by the Agency. Governmental ICs, by definition, involve restrictions that are generally within the traditional police power of state and local governments to impose and enforce. Among the more common governmental institutional controls are water and well use advisories and restrictions, well-drilling prohibitions, building permits, and zoning and other land use restrictions. (EPA92B).

.... § 104(c)(3) expressly requires that, before EPA provides remedial action at a site, the state in which the site is located must provide certain assurances, including an assurance of all future maintenance; if a state will not provide this assurance, it may be difficult to implement institutional controls. (EPA92B)

Typically, the mechanism for providing such an assurance is a Superfund cooperative agreement or a Superfund State Contract (SSC) in which the state, pursuant to CERCLA § 104(c)(3), assures EPA that it will operate and maintain a remedy. In many cases, the continued enforcement of the IC can be characterized as an aspect of the effective operation and maintenance (O&M) of a site. (EPA92B)

With a cooperative agreement or SSC in place, the state retains whatever authority it has to alter or permit the alteration of zoning or other use restrictions but is contractually obligated to EPA to continue the ICs to the extent it has the authority to do so. Thus if the remedy fails, EPA may be able (depending on applicable law), to pursue a breach of contract claim against the state. The ultimate utility of such an action may depend both on whether EPA prevails in the action, and, if it does, on whether it could obtain specific performance or would be limited to a damages remedy. (EPA 92B).

However, states may have delegated the types of police powers that are needed for ICs to local governments, which often are not parties to an agreement with EPA and are not required, under CERCLA, to give an O&M assurance. Since it is the state that has made the assurance, EPA's remedy for a failure of the control is from the state, which may not have the legal authority to prevent the local government from actions that might lead to failure of the IC, such as a zoning regulation change. (EPA92B).

This differs somewhat from other aspects (i.e., those not involving ICs) of O&M at a site for which the state has provided assurances but the local government implements the O&M. If the local government fails to carry out activities necessary to O&M, the state's O&M assurance would appear to obligate the state to step in. Nevertheless, while a state typically possesses the legal authority to carry out O&M, it may not have the legal authority to impose an institutional control. (EPA92B).

One approach to increasing the reliability of governmental ICs is to create a direct contractual relationship between EPA and the governmental entity responsible for implementing and enforcing the use restriction. In situations where the state proposes to have the local government implement O&M, arguably an adequate assurance should include some commitment by the local government to EPA in a three party agreement or to the state in a separate agreement, that it will not reduce or eliminate the necessary use restrictions; the effectiveness of such a commitment will depend in part on the extent that the commitments of the signatory government are binding on successive governments. In some cases, this could be done in a three-party SSC or a cooperative agreement. Before entering into such an agreement, Regional council should be consulted regarding the remedies available in the event of a breach. (EPA92B).

Where EPA is not providing remedial action, some comparable method of formalizing a contractual relationship between EPA and the state or local government in which EPA receives an assurance that the institutional control will remain in place may be useful. Cf. 40 CFR §§ 35.6200-6205 (authorizing removal response cooperative agreements). The mere fact that CERCLA does not require certain types of assurances in certain circumstances does not preclude the Agency from obtaining assurances needed to maximize protection of health and the environment at the site. (EPA92B).

A less formal, but perhaps more effective, means of ensuring the reliability of this type control is to emphasize obtaining community understanding of, and support for, the IC. A community's belief in the importance and appropriateness of an IC could, as a practical matter, increase the likelihood of adequate implementation of the control. (EPA92B).

It should be remembered, however, that political developments are unpredictable, and changes may render governmental ICs ineffective for long-term actions.

The United States has authority under CERCLA § 106(a) to issue orders or take other appropriate actions taken, as "may be necessary to protect public health and the environment" if there "may be an imminent and substantial endangerment." An order issued

under this authority may, in appropriate cases, require the implementation of institutional controls by other parties. In addition, the order itself, to the extent it effectively restricts or prohibits certain land uses, may function as an institutional control with respect to the party to whom it was issued. (EPA92B).

2.3.2 Proprietary Institutional Controls

Proprietary institutional controls (PICs) involve some form of ownership of an interest in the property. "With a proprietary control, a party owning sufficient rights in a property restricts the use of the property." (EPA92B). "The rights of property owners are generally defined by the property laws of the state where the property is located. This makes it critical to identify and understand the applicable property law principles as part of the process of developing an IC." (EPA92B). "Ideally, a proprietary control will be implemented with sufficient flexibility to allow all appropriate uses of the property, and to permit the owner to convey most interest in the property." EPA92B).

PICs can often be implemented, particularly in an enforcement context, under consent agreements between EPA and property owners. However, in some cases, implementation may require the acquisition of an interest in real property. Further, in some such situations, a necessary part of the response may be for EPA to acquire property on its own behalf. Whenever EPA acquires property, certain procedures and rules apply. (EPA92B).

As part of a remedial action, the Agency may "acquire, by purchase, lease, condemnation, donation, or otherwise, any real property or any interest in real property" under CERCLA § 104(j). A condition of the exercise of acquisition authority under CERCLA § 104(j) is that, before an interest in real estate is acquired, "the State in which the interest to be acquired is located assures...[EPA]... that the State will accept transfer of the interest following completion of the remedial action." § 104(j)(2). Where the property interest will be extinguished (e.g., a lease with a limited term or an easement for a specific term or purpose) by the completion of the remedial action, no assurance is necessary. (EPA92B).

EPA's Facilities Management and Services Division (FSMD) has sole authority within the Agency to acquire real property under Agency Delegation 1-4. In addition, CERCLA Delegation 14-30 requires the approval of the Assistant Administrator for Solid Waste and Emergency response, with the concurrence of the General Counsel, for all real property acquisitions, "by EPA or pursuant to a

cooperative agreement for response action, including a removal, remedial planning activity, or remedial action." After the necessary concurrences, the Hazardous Site Control Division sends a request for acquisition to FSMD. FSMD may complete the real estate transaction with its own personnel, by contract with a commercial firm, or through an Interagency Agreement with the U.S. Army Corps of Engineers or U.S. Bureau of Reclamation. (EPA92B).

"Full fee title obviously constitutes an interest in property which is sufficiently broad to support an IC, since fee owners can generally restrict the uses of their property as they see fit, within the limits imposed by applicable law." (EPA92B). Where title is held by a PRP, the IC can be enforced through an order or enforcement agreement. Alternatively, the government may take title itself. "... a sovereign may act in the capacity of a property owner and implement a proprietary IC subject to the same conditions that apply to a private party's proprietary controls." (EPA92B). "A lesser interest (preferably recordable) that encompasses rights and control over the property sufficient to enforce a use restriction could also be adequate." (EPA92B).

To implement a control through a privately held interest (either fee title or less), an enforceable agreement may be entered into with a party possessing a sufficient interest in the property to prevent the inappropriate use, in which the party formally agrees to enforce that right and prevent the use.

To ensure the reliability of such an arrangement, it may be desirable to clarify the terms and conditions under which the owner will enforce the restrictions and to address the possible conveyance of the property interest that provides the right to enforce the restriction, and the owner's continuing responsibility to enforce the restriction even where there has been a conveyance. Any such restriction, however, must be framed so that it does not violate the prohibition of restraints on alienation as reflected in the property law of the state where the restriction is to be imposed." (EPA92B).

"An easement is a common, reliable type of property interest sufficient for implementing a proprietary IC. Not only is an easement well-recognized at common law, but it has sufficient flexibility so that it can

be crafted to give the holder precisely the rights needed to restrict use of the property." (EPA92B). Easements can be crafted to include prohibitions on certain types of development including placement of buildings and excavation of soil. Easements can be obtained by purchase, donation, condemnation, etc. Easements "run with the land" and, therefore, bind successive owners.

A covenant running with the land, restricting uses of the property might be adequate, so long as some party has both the ability and willingness to enforce it. It might be useful to explore the possibility that a local community group, motivated by a desire to ensure adequate environmental protection of an area, might hold such an interest. In considering such a possibility, factors affecting the long-term viability of the group must be examined such as its likely longevity, resources for taking legal action to address violations of the control, and its ability to take various actions. (EPA92B).

Another alternative might be a reverter clause in a deed, by which the property reverts to a former owner or some other party if it is ever used in a prohibited way. Yet another option would be the creation of an irrevocable trust to hold the interest and ensure that the property is not used in the prohibited manner. (EPA92B).

Although interests less than fee title may be adequate to protect an IC, it is critical to ensure that, in fact, the party overseeing the IC will be able to manage use of the property in the desired ways. Certain instruments, for example those requiring privity, may not reliably ensure this, since the ability to enforce will cease, and the control may fail, once the property passes out of privity. However, to the extent that failure of such a control results in a CERCLA release, the owner or operator may be liable under CERCLA § 107. Moreover, the presence of a use restriction or notice in a deed would probably be relevant to the ability of a party to maintain an innocent landowner defense to liability. (EPA92B).

It should be obvious that if these kinds of controls are anticipated, early planning and consultation with Regional counsel is required.

REFERENCES FOR SECTION 2

- AEE92 - The Association of Energy Engineers, 1992 Innovative Radon Mitigation Design Competition, Atlanta, GA, 1992.
- EPA88 - U.S. Environmental Protection Agency, Radon Reduction Techniques for Detached Houses, EPA/625/5-87/019, Washington, DC, January 1988.
- EPA89 - U.S. Environmental Protection Agency, Radon Reduction Techniques in Schools, 520/1-89-020, Washington, DC, October 1989.
- EPA90 - U.S. Environmental Protection Agency, Residential Air-Cleaning Devices, 400/1-90-002, Washington, DC, February 1990.
- EPA91A - U.S. Environmental Protection Agency, Radon-resistant Construction Techniques for New Residential Construction, EPA/625/2-91/032, Washington, DC, February 1991.
- EPA91B - U.S. Environmental Protection Agency, Sub-Slab Depressurization for Low-Permeability Fill Material, 625/6-91-029, Washington, DC, July 1991.
- EPA91C - U.S. Environmental Protection Agency, Radionuclides in Drinking Water, 570/9-91-700, Washington, DC, June 1991.
- EPA92A - U.S. Environmental Protection Agency, A Citizen's Guide to Radon, 402-K92-001, Washington, DC, May 1992.
- EPA92B - "Use of Institutional Controls at Superfund Sites", Memorandum from David F. Coursen, Attorney-Advisor, to Howard F. Corcoran, Associate General Council - Grants, Claims and Intergovernmental Division. July 27, 1992.

SECTION 3 DEVELOPING AND SELECTING MITIGATION STRATEGIES

Mitigation of indoor air impacts from a CERCLA site may be accomplished by source control or by preventing the indoor exposure. The NCP requires the development and evaluation of a range of alternatives in the remedy selection process for a CERCLA site. There is a strong preference for source control. However, the NCP also requires the development of one or more alternatives that involve little or no treatment, but provide protection of human health and the environment by preventing potential exposures. Indoor air mitigation techniques that prevent indoor exposures, such as sub-slab depressurization and institutional controls, are examples of such alternatives.

This Section discusses procedures that can be used to develop alternative strategies to mitigate indoor air impacts occurring as a result of pollutant releases at a CERCLA site. It is recognized that mitigating these impacts is only a part of the overall activities being taken to clean-up the site. The indoor air mitigation strategy development process is considered one component in the overall site remediation plan and the utility of strategy elements are considered in the context of compatibility with the overall plan.

Addressed in this Section are development of indoor air mitigation objectives and the basic information needed in developing the indoor air mitigation alternatives. This Section also addresses identifying and selecting potential mitigation measures, and combining them into workable strategies from which a final strategy can be selected. Note specifically that selection of a remedy must be based on an evaluation of the alternatives against the nine NCP criteria (EPA88b). This document may only be used to assist in developing alternatives for evaluation; it cannot be used to conduct the required evaluation and select the remedy.

Matrix techniques are used that allow consideration of a wide range of possible strategies. Figure 3-1 illustrates the overall process suggested in this Section. These techniques allow the evaluation of a large amount of information in a relatively straightforward and concise manner. Although the matrix techniques use quantitative appearing procedures, it must be recognized that qualitative and subjective considerations are involved and, therefore, the result is not a definitive scientific analysis.

This document does not cover procedures for conducting remedial investigations, assessment of the indoor air impacts, or environmental and health risk assessments. The procedures assume that the indoor air impact has already been documented and the risks are such that mitigation has been determined to be necessary.

Application of the procedures is illustrated by development of a set of strategy alternatives for a hypothetical situation which makes use of information from an actual impacted site supplemented by fabricated information to provide additional complexity.

3.1 DEFINING THE OBJECTIVE

Objectives are statements of what outcome is desired. Objectives are accomplished by designing and implementing a cohesive set of appropriately chosen actions - the strategy. Before a workable strategy can be developed to mitigate specific indoor air impacts from a CERCLA site, it is essential that there be definite objectives. If clear objectives are not defined, it is quite possible to develop strategies that do not solve the existing problem, do not prevent recurrence of the problem, or that are excessively costly, cumbersome and complex. In some cases, the objective will be simple and straightforward. In other cases, there may be a number of objectives that cannot be simultaneously met, and which require an evaluation of strategies that provide the best overall solution.

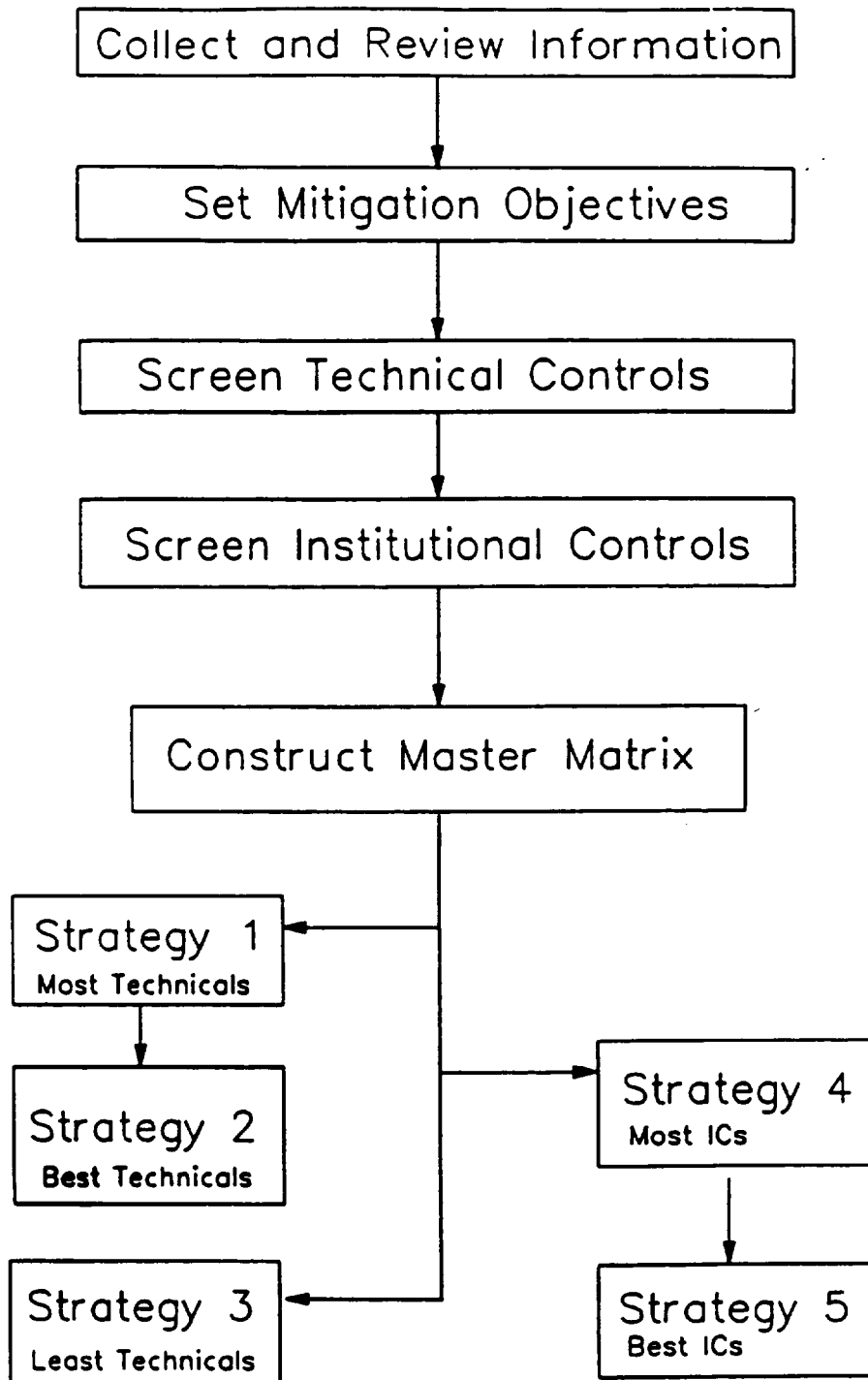

Figure 3-1. MITIGATION STRATEGY DEVELOPMENT

Objectives should be both general and specific. General objectives might be stated, for example, as "reduce the incremental site related cancer risk to the occupants to 10^{-6} ." A specific objective might be, "prevent indoor use of contaminated groundwater". The set of objectives developed become the standard against which the utility of the various technical and institutional controls that make up the strategy can be measured and also provides the focus needed to assist with project discussions with technical and legal experts.

Objectives can be easily thought of in three basic areas: selection of the mitigation level to achieve; reduction of current impacts; and reduction of future impacts. Each of these is discussed below. Objectives cannot be properly developed until the basic information about the site and affected properties required by Section 3.2 is available.

3.1.1 Mitigation Level Desired

The objective of mitigation is to reduce risks due to the release of pollutants from the CERCLA site. Reducing risks from pollutants from non-CERCLA site sources may occur as a side benefit to the strategy implemented. Mitigation of indoor air impacts may be accomplished by reducing the indoor air concentration of the pollutant and/or by reducing the occupants', or potential occupants' exposure to the pollutants. It is important, therefore, when defining the desired mitigation level not to focus solely on indoor air concentrations. However, the most effective strategies will likely be those that reduce the indoor air concentrations of the pollutants.

The first step is setting a goal for the mitigated concentration. This will take place as part of the feasibility study for the site. The information needed to establish this goal may be obtained from the baseline risk assessment or other investigation that concluded mitigation of indoor air impacts was necessary. The target level for each pollutant for each medium should be established at a concentration and intake that corresponds to an excess cancer risk of 10^{-6} or a hazard index of 1, whichever is lower. Note that if indoor air impact is from several chemicals and/or

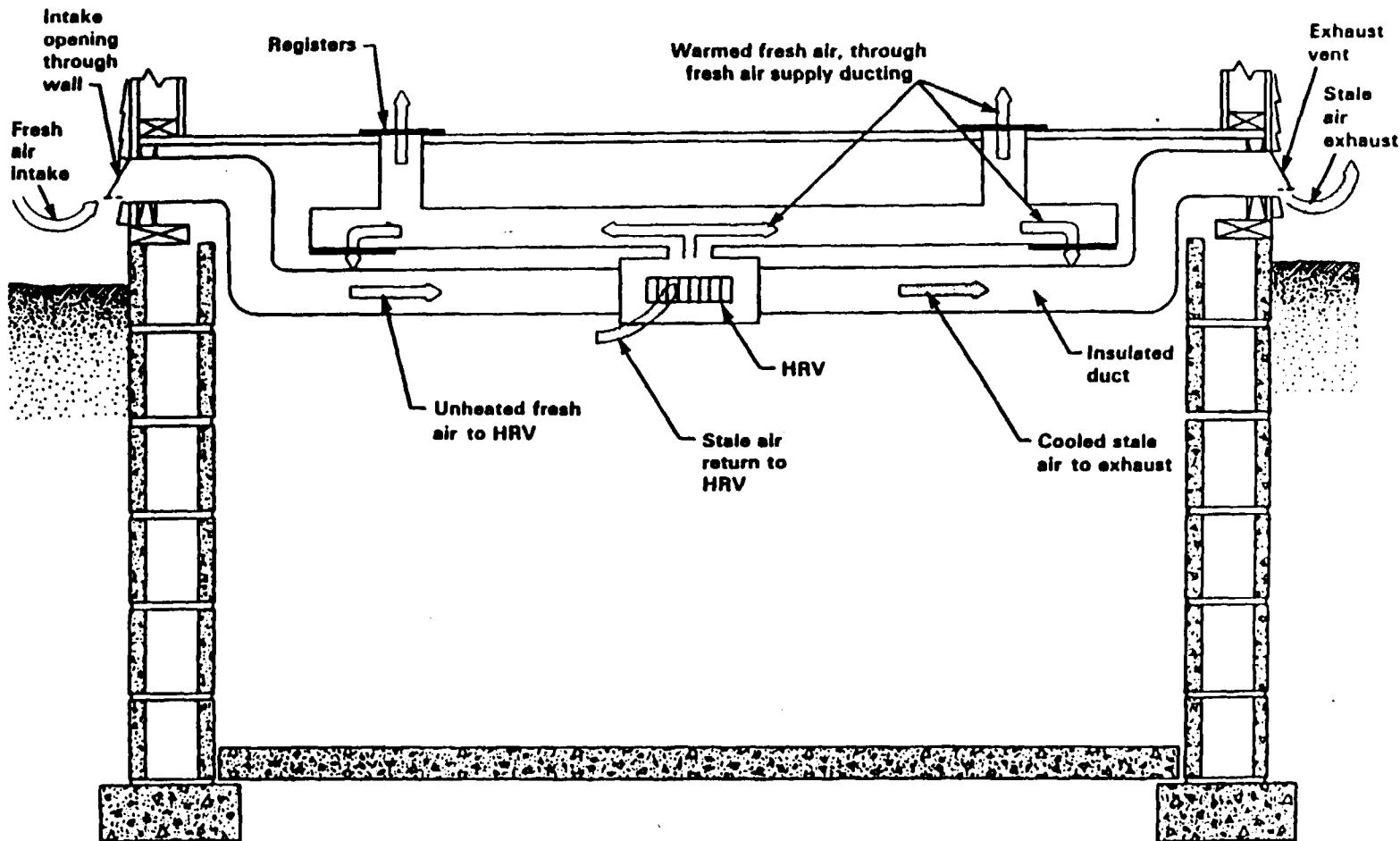

Note: Air flows are labeled for cold weather, where cold outdoor air is being warmed in the HRV. In hot weather, hot outdoor air would be cooled and dehumidified.

Source: EPA 87

Figure 2-9. Possible Configuration for a Fully Ducted HRV

3.2.1 Source Type, Strength, and Route of Impact

An understanding of the source, the type of contaminant generated from the source, and the transport mechanisms acting on the contaminant are vital to setting objectives for mitigation. The chemical and physical properties of the contaminants should be researched and understood. The toxicity, flammability, and reactivity of the contaminant will be important considerations when setting priorities and selecting mitigation objectives. The health effects and environmental impacts of exposure to the contaminants should be researched and understood. It is imperative to know what one is dealing with when developing a control strategy.

The physical location of the source of the contaminant and the extent of the contamination should be identified. Whether the source is on a remote property or on an adjacent property will give some indication of the scope of contamination, potential duration of its impact, and the concentrations to be expected. The presence of the contaminant in the local groundwater, ambient air, soil gas, or community well should be determined by acceptable analytical methods. Hydrogeological surveys, ambient air monitoring, soil gas testing, and groundwater testing may need to be conducted to fully understand the extent of the contamination and to make any necessary corrections for background levels.

The present status of the source should be determined. If the contaminant is still being released from the site, an evaluation of the effectiveness of control strategies used at the site to limit further release should be conducted. If no control strategies are in-place, the first objective of the mitigation plan may include controlling the source. The quantity of contaminant released from the source should be estimated. Based on available information the potential duration of the impact should be estimated.

The route of impact is a primary consideration when selecting a mitigation strategy. The route of impact is the physical movement of the contaminant from the source to the point of impact. Basically, three components comprise the route of impact. First, the transport mechanism deliv-

Air cleaners generally rely on filtration or ionization to remove particles from the air. The use of air cleaning to remove pollutants from the air in residential applications is in its infancy.

There are three general types of air cleaners to remove particles presently available in the market: mechanical filters; electronic air cleaners; and ion generators. Mechanical filters may be installed in buildings with central heating and or air conditioning or may be used in portable devices.

There are two major types of mechanical air filters: flat or panel filters, and pleated or extended surface filters. Flat or panel filters consist of either a low packing density of coarse glass fibers, animal hair, vegetable fibers or synthetic fibers which are often tactified to increase the holding capability and adhere to particulate materials. Flat filters may efficiently collect large particles, but remove only a small percentage of respirable sized particulate (RSP). Flat filters may also be made of "electret" media, consisting of a permanently-charged plastic film or fiber. Particles in the air are attracted to the charged material.

Pleated or extended surface filters generally attain greater efficiency for capture of RSP than flat filters. Their greater surface area allows the use of smaller fibers and an increase in packing density of the filter without a large drop in air flow.

Electronic air cleaners use an electric field to trap particles. Like mechanical filters, they may be installed in buildings with central HVAC systems or may be portable units with fans. Electronic air cleaners are usually electrostatic precipitators or charged-media filters. In electrostatic precipitators, particles are collected on a series of flat plates. In charged-media filter devices, which are less common, the particles are collected on the fibers of a filter. In most electrostatic precipitators and some charged-media filters, the particles are deliberately ionized (charged) before the collection process, resulting in a higher collection efficiency. Ion generators also use static charges to remove

3.2.1 Example - Understanding Source Type, Strength, and Route of Impact

A manufacturing facility is located about 200 yards from a residential community. One of the underground chemical storage tanks leaked TCE for an unknown period of time. The source of the leak has been stopped, however the TCE has migrated into the groundwater. The plume is currently defined as 300 yards wide extending 1,000 yards into the residential community. TCE has been detected in this plume at all depths between the top of the groundwater table, 5 feet below surface, to 50 feet below ground surface. Concentrations are an order of magnitude higher near the source than in the middle of the plume. Hydrogeological testing indicated the groundwater is moving from the facility toward the community at about 0.5 feet per day. Most of the buildings use water from a public surface water system located several miles from the community; however, a few of the older residences use private wells intersecting the plume.

A site investigation has been conducted. Monitoring at the site and affected buildings included soil gases, ambient air, and indoor air in the fall and winter. Indoor air impacts have been documented in a number of buildings. Indoor air concentrations of TCE ranged from 50 to 100 ppb/v. The data indicate that indoor concentrations are significantly higher when the ground is frozen or snow covered. The data also indicate that TCE volatilizing from the plume escapes through the surface when the ground is not frozen. The TCE in the ambient concentrations could migrate into the homes, however the ambient air concentrations were not high enough to be of concern during the monitoring period. Direct intrusion of the contaminated groundwater is not occurring.

The results obtained for frozen or snow covered ground may be related to increased building stack effects due to greater indoor-outdoor temperature differences. The results may also be related to the impermeability of the soil surface causing increased TCE concentrations in near surface soil gases. The ambient air concentrations of TCE in the immediate vicinity of the buildings is of interest because it tells us whether or not the ambient air pathway into the indoor air is important or not.

efficiency (i.e., rating above about 98 percent) filters. The test measures the percentage removal of 0.3 μm particles of DOP.

Removal of gaseous pollutants requires the use of a sorbent material. As mentioned earlier, removal of gaseous pollutants has been applied in industrial and manufacturing processes, but the effectiveness for removal of organic compounds in residential or commercial settings is not well-documented. In general, capacities of current sorbent systems are too low to be of practical use in mitigating indoor air impacts addressed in this document.

The most frequently used process for removing such contaminants from indoor air is sorption by solid sorbents. The effectiveness is dependent upon:

- air flow rate through the sorbent material,
- concentration of the pollutants in the air stream,
- presence of other gases or vapors (e.g., water vapor),
- physical and chemical characteristics of both the pollutants and the sorbent,
- configuration of the sorbent in the device, and
- the quantity of sorbent used as well as the bed depth.

Because the rate of pollutant capture by sorbents (i.e., efficiency) decreases with the amount of pollutants captured, air cleaners for gaseous pollutants are generally rated in terms of the sorption capacity (i.e., the total amount of the chemical that can be captured) and penetration time (i.e., the amount of time before capacity is reached). Sorbents can be engineered to remove specific gaseous pollutants such as formaldehyde or classes of compounds such as volatile organic chemicals (VOCs).

Activated carbon has been used to reduce indoor concentrations of low molecular weight gases and odors to imperceptible levels. Research addressing ability to remove high concentration of pollutants, useful life, holding capacity over time, and ability to adapt to variations in type and concentration of indoor pollutants is in progress.

- The type of foundation wall should be noted. Typically, foundation walls are constructed of cast-in-place concrete, concrete masonry units, stone, or brick. The foundation wall cavity, if present, may be ventilated to control the intrusion of contaminated soil gas.
- An estimate of the building's infiltration rate should be made (see EPA92). Loose construction joints and window/door seals will greatly increase the infiltration rate in a building. Potential major and minor entry routes for intrusion of soil gases and groundwater, and their accessibility for mitigation efforts, should be identified.
- The type of HVAC system in the building should be noted. Typical general systems include: forced-air, hot water w/baseboard radiators, etc. The on/off cycling, and whether the fan delivers a constant volume or a variable volume (usually found only in commercial buildings) of air during operation indicate if mitigation using building pressure adjustments with existing HVAC components is a viable option.
- The property's water source(s) should be identified. Typically, water is provided by a private or community well, or a public source.

Certain site characteristics are also necessary to make an informed mitigation selection. The following information should be obtained from building records, site plans, and soil surveys:

- Depth of Water Table - monthly depth variations
- Frost Line - monthly depth variations
- Soil Type and Permeability
- Well Depth and Water Source

3.2.2 Example - Building Structural Features

There are two types of buildings in the residential community located near the manufacturing facility: two-story condominiums built in clusters of four units on a common slab, and single-family detached housing on slab

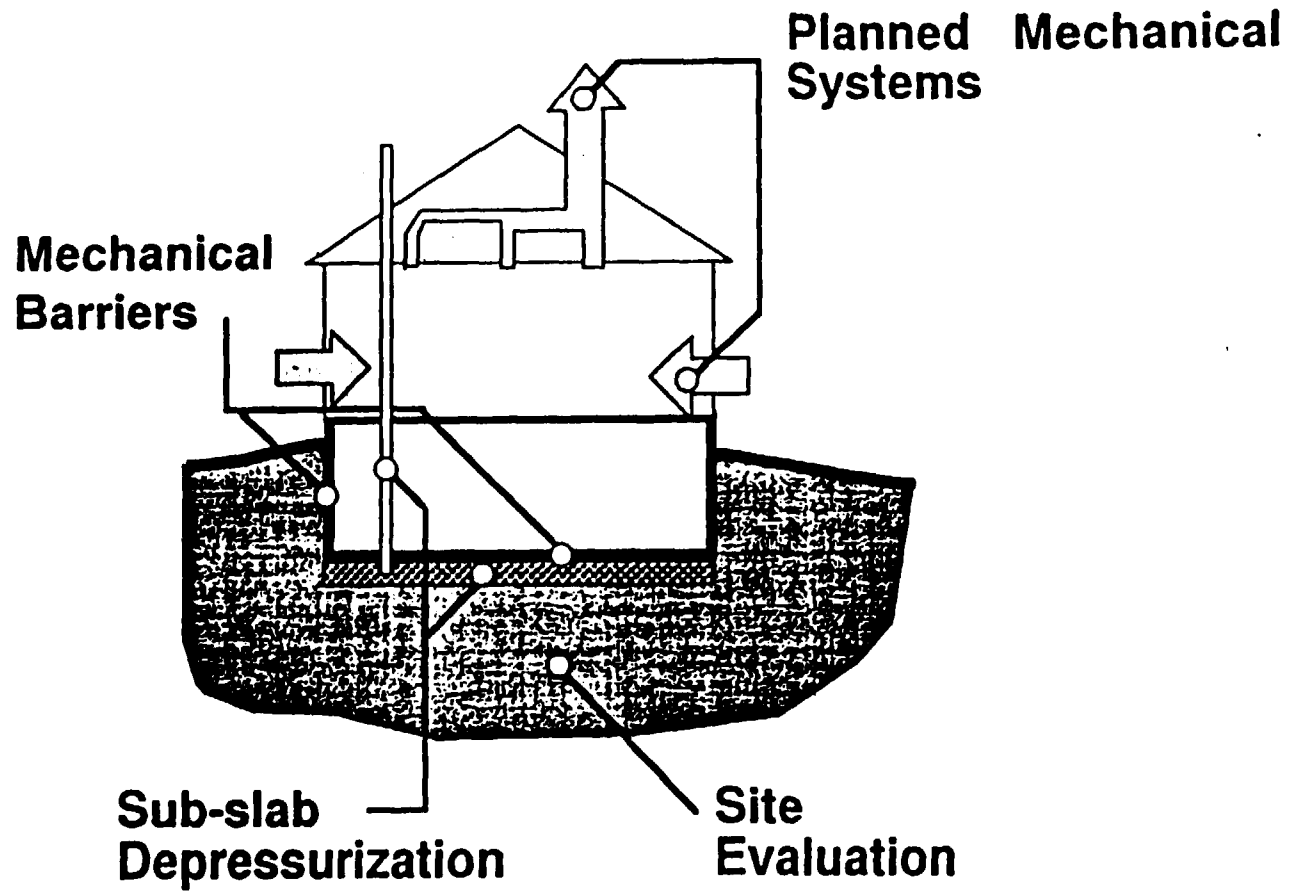

Source: EPA91A

Figure 2-10. New Construction Techniques

tration would fall within typical ranges. Two-story buildings predominate but several are three story. Utilities penetrate both the slab and above grade walls. Heat for all buildings is by forced air oil furnaces located on the lower floor. All homes use private wells and septic systems. Floor drains in the utility room connect to the septic system.

The poured concrete slabs and walls suggest there are probably few openings through which soil gases could enter the buildings. Unsealed utility penetrations are the most likely entry points. It is possible, however, that some soil gases may be channeled to upper floors through the gap between the frame and the brick veneer. Because these homes use wells that may intersect the contaminated groundwater plume, volatilization of contaminants from indoor water uses (i.e., showering, cooking) is likely. Also, septic system drain fields provide an excellent collection system for soil gases which can enter the houses if the floor drains do not include traps or if the traps are not water filled. If, as suspected, the slabs were poured directly on the ground, it is likely that sub-slab soil permeability is low and ventilation of soil gases would be limited to regions near the ventilation points. Because fired equipment, such as the oil furnaces, withdraw air from the houses, they can increase the buildings' underpressurization and cause more soil gas to be drawn into the buildings. Also, if a depressurization system is used for soil ventilation, care must be exercised to ensure that furnace backdrafting is not caused by withdrawing too much air from the house through unsealed gaps in the structure.

3.2.3 Current and Potential Future Uses

The present, future, or intended uses of the building and site should be identified. The selected mitigation method should be based on goals and objectives that account for known long-term use changes and short-term use adaptations. Changes in use could affect the types of systems considered, the maintenance requirements of the system(s), and the level of protection required of the system.

techniques not likely to all be found at a specific building. A properly roughed-in system would involve a good layer of aggregate beneath the floor slab and a capped PVC pipe at a central ventilation point. A network of perforated drain tiles beneath the slab and tied to the ventilation point has also been used (Figure 2-12). If a good layer of aggregate is installed, it is not necessary to install such a network.

Passive sub-slab ventilation systems may be installed by the developer which allow for the future installation of an in-line fan. If elevated contaminant levels occur when the system is operating passively, a fan could easily be mounted on the existing passive vent stack for little more than the cost of the fan. Again, the developer should ensure a good layer of permeable aggregate is placed beneath the floor slab.

2.2.5.2 Mechanical Barriers

Theoretically, a gas-tight barrier may be placed between the soil and the building foundation to eliminate the possibility of soil gas intrusion. (Figure 2-13). The types of mechanical barriers that have been tried or suggested may be categorized as follows:

- Foundation Materials
- Coatings
- Membranes
- "Site" Barriers

Foundation materials may form a mechanical barrier. New construction typically incorporates cast-in-place concrete in the foundation. The entire foundation or merely the footings and floor slab are usually cast-in-place. Concrete masonry walls and their mortar joints can provide minor entry routes for soil gases. Solid or filled blocks should be placed as the bottom and top course of a concrete masonry wall. Dampproofing or waterproofing treatments inhibit soil gas migration and are typically required by building codes. If conventional foundation construction techniques are used, the constructor should ensure that possible entry routes are treated with a sealant after construction is completed.

This section suggests a method for assessing the effectiveness of indoor air control methods. It does not substitute for the selection process set out in the NCP; rather, it suggests an approach that could be used in assessing one or more of the factors that the NCP requires EPA to evaluate in making removal or remedial decisions.

In order to evaluate potential technical mitigation measures, first organize all available and necessary information related to the remediation site. A table should be prepared, listing in column 1 the objectives defined above. Five additional columns will be used to list potential control methods and subjective ratings (see example, Table 3.1). It is suggested that a zero (infeasible) to 5 (high confidence) rating scale be used for the subjective rating of criterion used in the decision making process.

The second column should have the heading "Mitigation Methods." In this column list all technical control methods applicable to the objectives in column 1. In the third column, rate the potential control effectiveness of this method. The likelihood of achieving the mitigation goals should be evaluated. For example, if a 90% reduction in indoor contaminant levels were the goal of a particular mitigation problem, sub-slab ventilation might receive a 5 in certain specific cases, and sealing of entry routes might receive a 1.

The fourth column should be given the heading "Feasibility." The practicability of each mitigation measure should be evaluated and rated. Measures that can not be implemented, such as constraints due to the building's structural features, should be given a zero. For example, drain tile ventilation can not be considered a viable option for a building without a drain tile system. Mitigation measures which require modifications to structural, architectural, mechanical, or electrical systems should be subjectively rated in terms of their relative practicality.

The fifth column should be given the heading "Rough Cost". Ratings for costs should be in the order: 5 for least cost; 0 for most expensive.

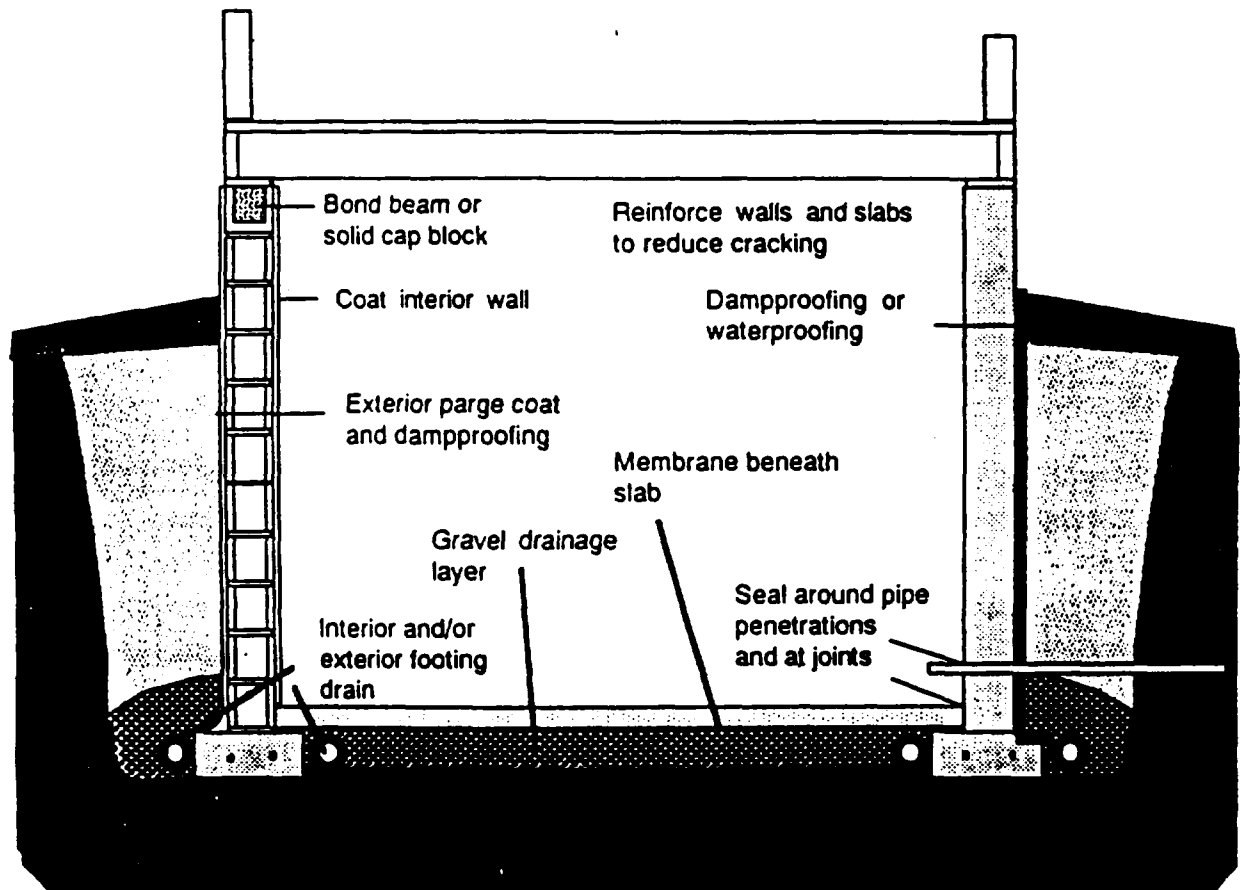

Source: EPA91A

Figure 2-13. Summary of Mechanical Barrier Approach

Table 3.1 Technical Control Options

Objectives	Mitigation Methods	Control Possible	Feasibility	Rough Cost	Rating
Prevent use of well water	<ul style="list-style-type: none"> • Alternate water source • Treat well water 	5	3	3	45
		2	2	1	4
Reduce exposure to soil gas intrusion into condos	• Drain tile Ventilation (passive)	2	5	4	40
	• Drain Tile Ventilation (active)	4	5	4	80
	• Sub-slab ventilation	4	4	3	48
	• Seal openings	1	2	2	4
	• Modify ventilation	2	2	3	12
Reduce exposure to soil gas intrusion into single-family houses	• Drain tile Ventilation	4	0	1	0
	• Sub-slab ventilation	4	2	2	16
	• Seal openings	2	2	3	12
	• Modify ventilation	3	3	4	36
Prevent use of inappropriate construction methods	none				
Reduce contaminant concentrations in ground-water	<ul style="list-style-type: none"> • Pump and treat at community /source boundary • Pump and treat in community 	4	4	4	64
		4	3	2	24

Foil faced, High Strength Bubble Pack has a high compression strength and doubles as an insulator. This material is somewhat fragile and is susceptible to puncture. Therefore, its ability to endure the construction and installation process make its applicability questionable.

A product using aluminum foil facing on two sides with an asphalt coating over a glass scrim webbing has potential but has not been tested for its resistance capability. The product will likely perform similarly to other foil faced products. It also is susceptible to puncture during installation.

PVC and EPDM membranes are very durable and have been used for mitigation of radon in existing houses. Both were originally developed as roofing membranes and can provide air-tight seals, if properly installed.

2.2.5.3 MECHANICAL SYSTEM DESIGN

Potential indoor air impacts should be addressed in the HVAC system design and operation. The HVAC system should be designed to:

- help control soil gas influx,
- allow controlled volumes of outdoor dilution air to enter the building, and
- maintain an acceptable indoor temperature and relative humidity range to the building.

Controlling soil gas influx by mechanical means may be accomplished by establishing a positive pressure on the lower (at and below grade) levels of the building. This is achieved by simply introducing a larger volume of air into the space than is exhausted from the space. That is, the total cubic feet of air supplied to the space should be greater than the total cubic feet of air exhausted from the space.

Other ventilation system features may be incorporated to reduce indoor contaminant concentrations, reduce soil gas entry, or otherwise increase the acceptability of the system. For example heat recovery ventilators

throughout the community. Note that this would likely be considered as part of the overall site remediation plan, not just for indoor air concerns.

Each of these methods must be rated for control capability, feasibility and rough costs. If an uncontaminated alternative water supply is provided for the houses, control of this source is 100 percent; thus, a 5 rating is given for control. Connection to the public water supply, which is already in the community serving the condominiums, is feasible. However, because at this point we do not know the design capacity of the water lines, a feasibility rating of 3 is assigned. A rough cost rating of 3 is assigned because a water distribution system is nearby and there are only a few houses to service. Treating well water at each of the houses receives lower ratings in all categories because contaminant removal is not as good, and significant modifications may be necessary to install properly sized systems.

Passive drain tile ventilation systems for the condominiums are given high ratings for feasibility and rough cost because the tiles exist and the systems can be installed simply. Control capability is rated low, however, because the system may not achieve the 95 percent mitigation objective in cold weather and may not perform well in warm weather. Active drain tile ventilation is assigned a higher control rating, but is not given a 5 because of uncertainty about the effectiveness of control for gases rising near the center of the slabs. That is, the tiles and/or aggregate under the slabs may be partially plugged by silt reducing the vacuum effect far from the tiles.

Sub-slab ventilation was assigned uniformly higher rating for the condominiums than for detached houses primarily because of the high probability of the presence of a permeable gravel layer beneath the condominiums' slabs. This indicated the likelihood of good sub-slab ventilation with a minimum of slab penetrations for vent pipes, associated piping, and interior remodeling. Sealing soil gas intrusion openings as a stand alone control technique was assigned low rating for the condominiums because of

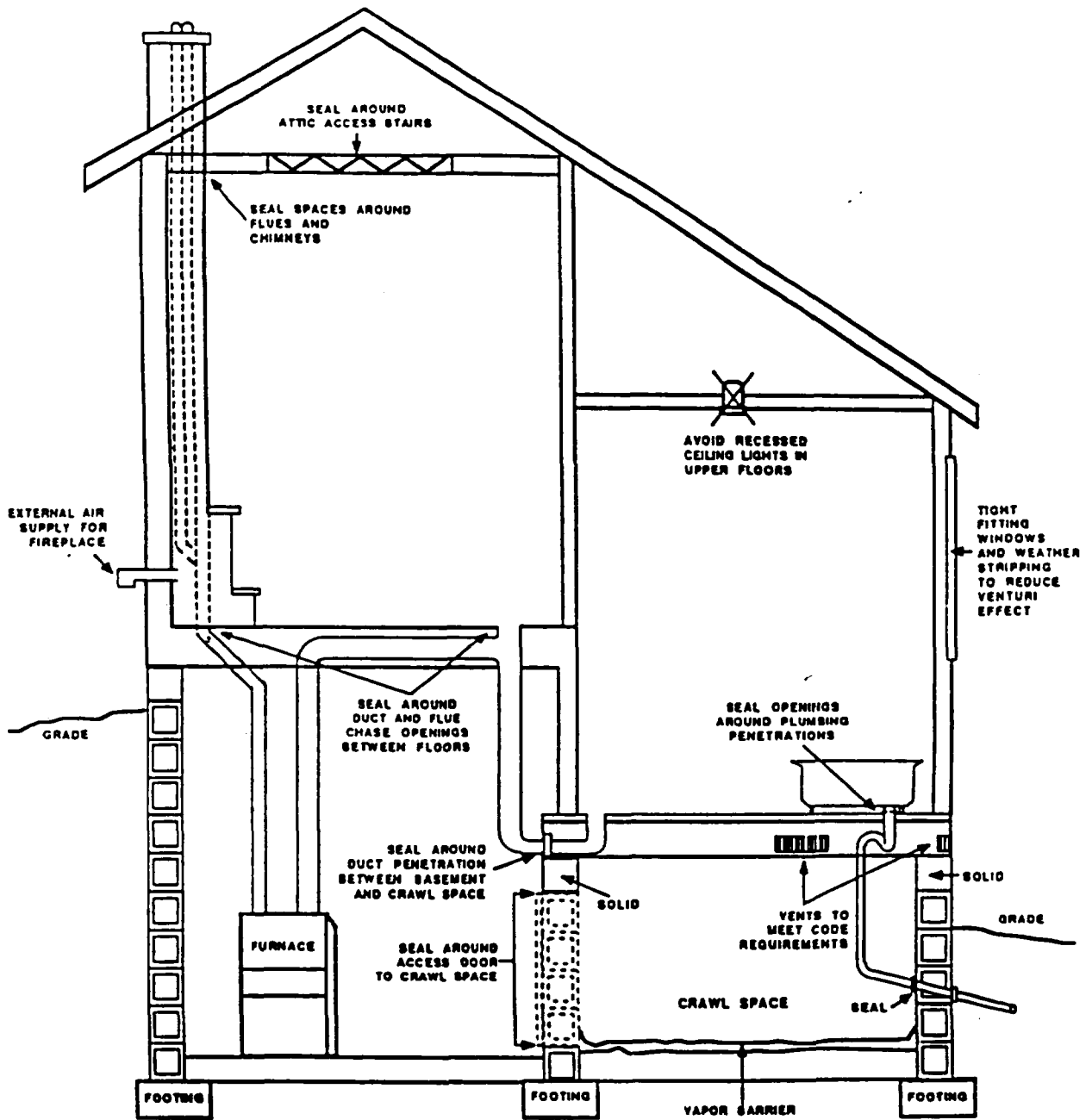

Source: EPA87

Figure 2-14. Methods to Reduce the Vacuum Effect

rating scale be used. The following can be considered as a general guide although site specific considerations may affect the analysis:

- The shorter the term of the IC, the more likely it is to be reliable.
- ICs based on property interests may be more effective than those based on police powers if the IC must be effective over a long period of time and if there is a party with the authority and incentive for long-term enforcement of the IC.
- As a general matter, property interests are likely to be reliable in the descending order (remember, however, that Federal interests must be transferred upon completion of the remedial action): Federal has full fee title, State has full fee title and a Superfund State Contract is in place, Federal or State owns a recordable interest, PRP owns interest and a Consent Agreement is in place, and private party (e.g., local community group) owns interest. In the case of private party interest, enforcement would be very difficult.
- ICs involving three party agreements (Federal, State, and Local governments) are effective only to the extent that the commitments are binding on successive city and county governments.

The table now provides an estimate of the relative effectiveness of each IC for each objective. This table and the similar one developed for technical measures can now be used in developing a set of strategies for the mitigation.

3.3.2 Example - Estimated Effectiveness of Institutional Controls

For the example, the summary for potential effectiveness of institutional controls is given in Table 3.2. Column 1 of that table lists the mitigation objectives as before and in column 2 the potential institutional controls are listed for each objective (there is no implication here that the list is complete or appropriate). Buying some or all of the involved properties is listed for completeness. This option will appear frequently

Regional counsel be consulted as soon as it appears that ICs may be needed. Failure to do so may negatively impact the range of ICs that may be considered or the timeliness with which they may be implemented. Assessing effectiveness of ICs is discussed in Section 3.3.2.

2.3.1 Governmental ICs

As the NCP points out, institutional controls typically are unlikely to be implemented by the Agency. Governmental ICs, by definition, involve restrictions that are generally within the traditional police power of state and local governments to impose and enforce. Among the more common governmental institutional controls are water and well use advisories and restrictions, well-drilling prohibitions, building permits, and zoning and other land use restrictions. (EPA92B).

.... § 104(c)(3) expressly requires that, before EPA provides remedial action at a site, the state in which the site is located must provide certain assurances, including an assurance of all future maintenance; if a state will not provide this assurance, it may be difficult to implement institutional controls. (EPA92B)

Typically, the mechanism for providing such an assurance is a Superfund cooperative agreement or a Superfund State Contract (SSC) in which the state, pursuant to CERCLA § 104(c)(3), assures EPA that it will operate and maintain a remedy. In many cases, the continued enforcement of the IC can be characterized as an aspect of the effective operation and maintenance (O&M) of a site. (EPA92B)

With a cooperative agreement or SSC in place, the state retains whatever authority it has to alter or permit the alteration of zoning or other use restrictions but is contractually obligated to EPA to continue the ICs to the extent it has the authority to do so. Thus if the remedy fails, EPA may be able (depending on applicable law), to pursue a breach of contract claim against the state. The ultimate utility of such an action may depend both on whether EPA prevails in the action, and, if it does, on whether it could obtain specific performance or would be limited to a damages remedy. (EPA 92B).

However, states may have delegated the types of police powers that are needed for ICs to local governments, which often are not parties to an agreement with EPA and are not required, under CERCLA, to give an O&M assurance. Since it is the state that has made the assurance, EPA's remedy for a failure of the control is from the state, which may not have the legal authority to prevent the local government from actions that might lead to failure of the IC, such as a zoning regulation change. (EPA92B).

effectiveness, implementability, and costs. Effectiveness refers to the combined effect of the alternative components in protecting human health and the environment. Implementability refers to the feasibility of constructing, operating, and maintaining technical components and to the administrative requirements such as obtaining approvals from other offices and Agencies. Costs include capital, operating, and maintenance costs for technical and institutional controls. For screening purposes, it is more important that costs be compared on a common basis than that they be highly accurate.

Review the lists of technical and institutional controls developed for each objective and eliminate those with poor ratings (however, if there is only one control for any objective, retain it even if it has a poor rating). The controls remaining form the set of options from which to choose to develop the various strategy options.

The straightforward way to develop the set of strategy options would be to begin by constructing a matrix of all controls and objectives developed in preceding parts of this Section. Again, this approach is not required by the NCP or EPA policy; it is simply one suggested way of performing the screening process provided for by the NCP. That matrix could be decomposed to form strategy options by making all possible combinations of technical and institutional controls for the objectives. This approach is likely to produce a large number of strategies to evaluate, many of which would be comprised of poorer options. In the approach below, the matrix is decomposed into five strategy types ranging from as complete reliance on technical controls as possible to as complete reliance on institutional controls as possible. The strategy types are:

- Strategy 1 "Most Technical" - A technical control is chosen for as many objectives as possible. ICs are selected to supplement the technical controls, where needed.
- Strategy 2 "Best Technical" - Only the best technical controls are used. ICs are selected to supplement the technical controls, where needed.

under this authority may, in appropriate cases, require the implementation of institutional controls by other parties. In addition, the order itself, to the extent it effectively restricts or prohibits certain land uses, may function as an institutional control with respect to the party to whom it was issued. (EPA92B).

2.3.2 Proprietary Institutional Controls

Proprietary institutional controls (PICs) involve some form of ownership of an interest in the property. "With a proprietary control, a party owning sufficient rights in a property restricts the use of the property." (EPA92B). "The rights of property owners are generally defined by the property laws of the state where the property is located. This makes it critical to identify and understand the applicable property law principles as part of the process of developing an IC." (EPA92B). "Ideally, a proprietary control will be implemented with sufficient flexibility to allow all appropriate uses of the property, and to permit the owner to convey most interest in the property." EPA92B).

PICs can often be implemented, particularly in an enforcement context, under consent agreements between EPA and property owners. However, in some cases, implementation may require the acquisition of an interest in real property. Further, in some such situations, a necessary part of the response may be for EPA to acquire property on its own behalf. Whenever EPA acquires property, certain procedures and rules apply. (EPA92B).

As part of a remedial action, the Agency may "acquire, by purchase, lease, condemnation, donation, or otherwise, any real property or any interest in real property" under CERCLA § 104(j). A condition of the exercise of acquisition authority under CERCLA § 104(j) is that, before an interest in real estate is acquired, "the State in which the interest to be acquired is located assures...[EPA]... that the State will accept transfer of the interest following completion of the remedial action." § 104(j)(2). Where the property interest will be extinguished (e.g., a lease with a limited term or an easement for a specific term or purpose) by the completion of the remedial action, no assurance is necessary. (EPA92B).

EPA's Facilities Management and Services Division (FSMD) has sole authority within the Agency to acquire real property under Agency Delegation 1-4. In addition, CERCLA Delegation 14-30 requires the approval of the Assistant Administrator for Solid Waste and Emergency response, with the concurrence of the General Counsel, for all real property acquisitions, "by EPA or pursuant to a

Strategy 3 "Least Technical" - The least number of technical controls are used. ICs are selected to supplement the technical controls, where needed.

Strategy 4 "Most ICs" - ICs are used for as many objectives as possible. These are supplemented by technical controls, where needed.

Strategy 5 "Best ICs" - The best ICs are used. These are supplemented by technical controls, where needed.

The first three strategies rely heavily on technical controls, a preference expressed in the NCP. They vary in the number of different types of controls considered and the quality of those controls. This allows flexibility in choosing controls and strategies that are compatible with the overall site remediation plan.

The last two strategies rely primarily on institutional controls. These are provided to cover situations in which (1) no technical control strategy provides adequate protection during or following completion of remedial actions, (2) indoor air impacts will be mitigated quickly by site remediation activities and ICs would be adequately protective and cost effective, and (3) mitigation of indoor air impacts using ICs best complements the overall site remediation plan.

Master Matrix Table:

- Begin by constructing a matrix table with 4 columns: Objective, Technical Control, Institutional Control, and Probable Costs. See example, Table 3.3.
- Subdivide the technical and institutional control columns into three columns: control, frequency, and rating.
- Fill in the Objectives column.

be crafted to give the holder precisely the rights needed to restrict use of the property." (EPA92B). Easements can be crafted to include prohibitions on certain types of development including placement of buildings and excavation of soil. Easements can be obtained by purchase, donation, condemnation, etc. Easements "run with the land" and, therefore, bind successive owners.

A covenant running with the land, restricting uses of the property might be adequate, so long as some party has both the ability and willingness to enforce it. It might be useful to explore the possibility that a local community group, motivated by a desire to ensure adequate environmental protection of an area, might hold such an interest. In considering such a possibility, factors affecting the long-term viability of the group must be examined such as its likely longevity, resources for taking legal action to address violations of the control, and its ability to take various actions. (EPA92B).

Another alternative might be a reverter clause in a deed, by which the property reverts to a former owner or some other party if it is ever used in a prohibited way. Yet another option would be the creation of an irrevocable trust to hold the interest and ensure that the property is not used in the prohibited manner. (EPA92B).

Although interests less than fee title may be adequate to protect an IC, it is critical to ensure that, in fact, the party overseeing the IC will be able to manage use of the property in the desired ways. Certain instruments, for example those requiring privity, may not reliably ensure this, since the ability to enforce will cease, and the control may fail, once the property passes out of privity. However, to the extent that failure of such a control results in a CERCLA release, the owner or operator may be liable under CERCLA § 107. Moreover, the presence of a use restriction or notice in a deed would probably be relevant to the ability of a party to maintain an innocent landowner defense to liability. (EPA92B).

It should be obvious that if these kinds of controls are anticipated, early planning and consultation with Regional counsel is required.

frequency of 2. Under the institutional controls, only property purchase was listed by more than one objective in Table 3.2. The ICs are listed by all objectives to which they apply and the appropriate frequency of their appearance given. The potential effectiveness ratings given in Tables 3.1 and 3.2 are given in Table 3.3 for each type structure.

The next step is the actual development of the strategies using the matrix table above.

Strategy 1 - "Most Technical"

Illustrated in Figure 3-2 is the process for developing Strategy alternative 1 which is described below.

- Use a copy of the master matrix table.
- In the second column (Technical Controls) of the table, for each objective for which a technical control is given, place a check mark by the control with the highest effectiveness rating for that objective. Flag all occurrences of that control. If two or more controls have the same highest effectiveness rating for an objective, additional "Strategy 1" options can be developed by using each sequentially.
- Delete all unchecked and unflagged technical controls.

At this point, the best technical control for each objective, even if it is a poor control, has been selected. Also shown are the technical controls selected for other objectives which supplement the effectiveness of the selected control for each objective. Make a copy at this point for use in developing Strategy 2.

Institutional controls must now be chosen to supplement those technical controls that would not satisfy the objectives.

- Begin with objectives for which there is no technical control. Check the lowest effectiveness rated IC that will, at the least, ensure that the objective is satisfied.

SECTION 3
DEVELOPING AND SELECTING MITIGATION STRATEGIES

Mitigation of indoor air impacts from a CERCLA site may be accomplished by source control or by preventing the indoor exposure. The NCP requires the development and evaluation of a range of alternatives in the remedy selection process for a CERCLA site. There is a strong preference for source control. However, the NCP also requires the development of one or more alternatives that involve little or no treatment, but provide protection of human health and the environment by preventing potential exposures. Indoor air mitigation techniques that prevent indoor exposures, such as sub-slab depressurization and institutional controls, are examples of such alternatives.

This Section discusses procedures that can be used to develop alternative strategies to mitigate indoor air impacts occurring as a result of pollutant releases at a CERCLA site. It is recognized that mitigating these impacts is only a part of the overall activities being taken to clean-up the site. The indoor air mitigation strategy development process is considered one component in the overall site remediation plan and the utility of strategy elements are considered in the context of compatibility with the overall plan.

Addressed in this Section are development of indoor air mitigation objectives and the basic information needed in developing the indoor air mitigation alternatives. This Section also addresses identifying and selecting potential mitigation measures, and combining them into workable strategies from which a final strategy can be selected. Note specifically that selection of a remedy must be based on an evaluation of the alternatives against the nine NCP criteria (EPA88b). This document may only be used to assist in developing alternatives for evaluation; it cannot be used to conduct the required evaluation and select the remedy.

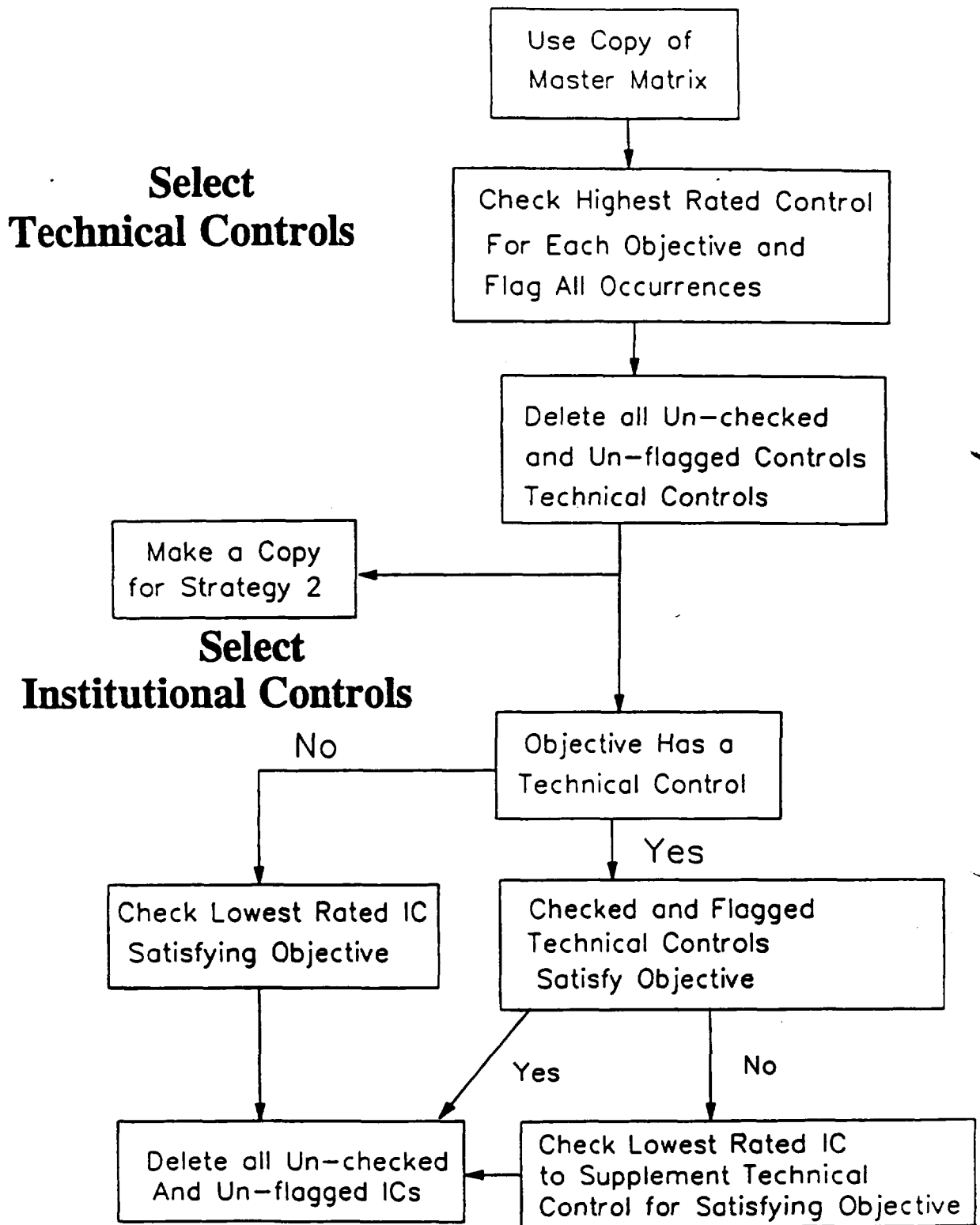

Figure 3-2. STRATEGY 1 - MOST TECHNICAL

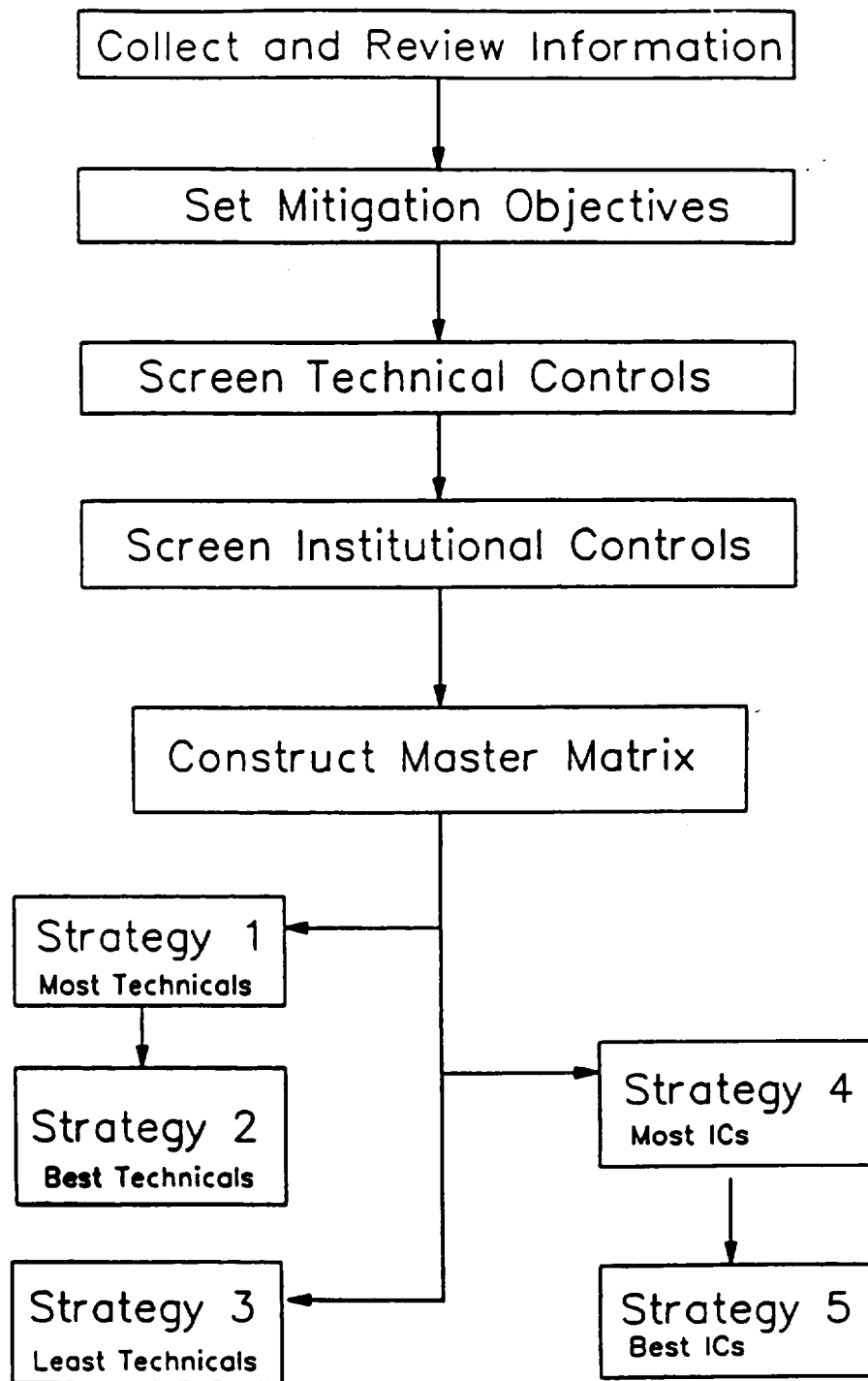

Figure 3-1. MITIGATION STRATEGY DEVELOPMENT

building permit process was selected. The IC would have to ensure that local building codes included a provision that any structure built in the affected area would have to include connection to the public water supply and use construction techniques designed to prevent soil gas intrusion. A consent agreement with the PRP was selected to ensure the pump and treat technical control was installed, operated and maintained. The completed Strategy 1 is shown in Table 3.4.

Strategy 2 - "Best Technical"

Illustrated in Figure 3-3 is the process for developing strategy alternative 2 which is described below.

- Use the copy made previously in developing Strategy 1.
- Review the checked technical controls only and delete all except those with the two highest effectiveness ratings.
- If no technical controls were deleted, Strategies 1 and 2 will be identical and there is no need to proceed with this strategy.

ICs must now be selected for objectives for which there is no technical control or for which the technical controls will not satisfy the objective. The process for making these selections is the same as described under Strategy 1. After the ICs are selected, Strategy 2 is complete. It is composed of technical controls with the two highest effectiveness ratings and the minimum level ICs necessary to supplement the technical controls for each objective.

3.4.1 Example - Strategy 2, "Best Technical"

The checked ratings for technical controls in Table 3.4 (45, 80, 36, and 64) were reviewed and the highest two (80 and 64) identified. Technical controls not having these two high ratings were deleted from the table. This leaves only active drain tile ventilation for the condominiums and pump and treat for the groundwater. ICs must now be selected to supplement the technical controls. Because in this strategy no source of uncontami-

several media, the total risks will likely exceed these values. The goal is an initial guideline. It does not establish that mitigation to that level is warranted; preliminary remediation objectives may be modified during the remedy selection process.

3.1.2 Reduce Impacts for Current Property Usage

Impacts for current property usage are those that are or might occur as a consequence of the existing property usage. For example, if the property is high-density residential and expected to remain in this usage, the mitigation objective must consider reduction of both short-term risks and long-term risks for this usage.

3.1.3 Reduce/Prevent Impacts for Future Property Usage

Objectives must also be developed to deal with potential changes in land use for the period that adverse CERCLA site impacts are expected. This includes potential development of undeveloped property as well as changes in usage. Typical changes might include conversion to higher density usage, such as agricultural to rural, rural to urban, and industrial to residential. Land use assumptions should be consistent with the Agency policies generally applicable to CERCLA risk assessments.

3.2 BASIC INFORMATION NEEDS

Prior to analyzing mitigation options for a property, information related to the source of the contaminant, the fate and transport of the contaminant, the structural features of the building(s) being affected, and the mitigation methods available should be gathered. This information will enable evaluation and assessment of the situation and definition of the mitigation objectives which lead to making an informed, cost-effective selection decision. This information will generally be obtained in the Remedial Investigation, assessments of impacts on specific buildings, removal assessment, and from Section 2 of this document. Certain specific information related to building characteristics may need to be determined. Some useful procedures are described in references EPA88a and EPA92.

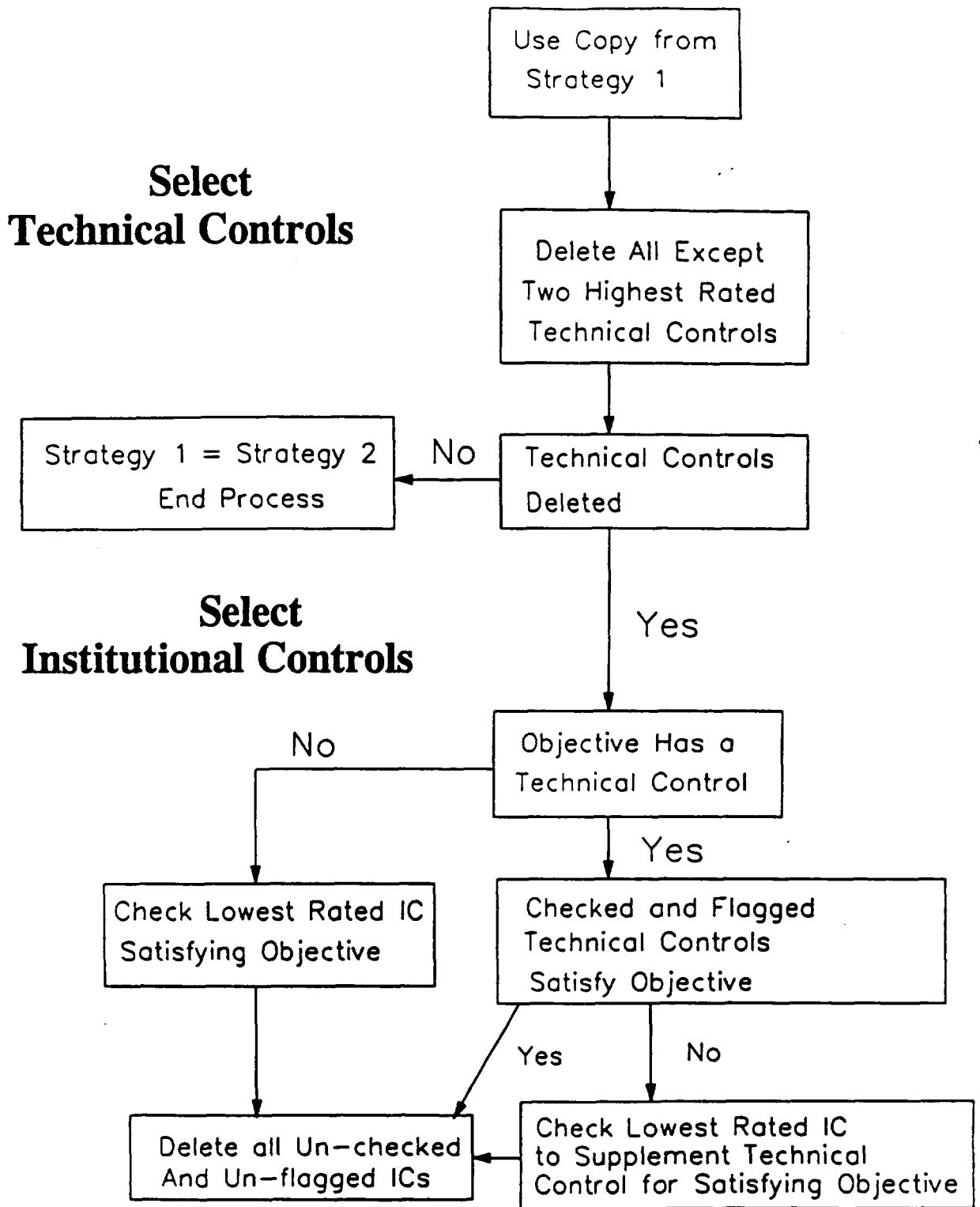

Figure 3-3. STRATEGY 2 - BEST TECHNICAL

ers the contaminant from the source to the building. Second, the means of intrusion allows the contaminant to enter the building envelope to reach the point of impact. Finally, the impact occurs in the form of health effects from exposure to the contaminant.

The transport mechanism causing the migration of the contaminant from the source to the impacted building should be identified. Typically, transport mechanisms fall into one of the following categories:

- Ground Water Migration (or Ground Water Plume)
- Soil Gas Migration
- Ambient Air (Wind Currents)

Based on the analytical results conducted to determine the extent of the contamination, transport mechanisms should be identified. The transport mechanisms should be placed in rank order according to their relative contribution to the transport of the contaminant. The highest ranking transport mechanisms should be identified for control by defining them as mitigation objectives.

As there are several transport mechanisms, there are several means of intrusion. The principal means of intrusion may be categorized as follows:

- Infiltration - Ambient Air
- Infiltration - Soil Gas Intrusion
- Ground Water Intrusion
- Diffusion through Building Materials
- Well Water
- Carried on clothing or shoes (e.g., contaminated soil)

Based on the transport mechanisms acting on the contaminant and the results of the analytical site assessment, the above means of intrusion may be placed in rank order according to their relative potential contribution to the intrusion of the contaminant. The highest ranking should be identified for control by defining them as mitigation objectives.

Table 3.5 Strategy 2 Matrix Table

Objectives	Technical Controls			Institutional Controls			Probable Cost
	Control	Freq.	Rating	Control	Freq.	Rating	
Prevent use of well water				Buy the properties	4	5	
Reduce exposure to soil gas intrusion into condos	Drain Tile Ventilation (a)	1	80				
Reduce exposure to soil gas in single-family houses				Buy the property	4	5	
Prevent use of inappropriate construction methods	None			Use local building permit process	1	3	
Reduce contaminant concentrations in groundwater	Pump and treat at community/source boundary	1	64	Consent agreement with PRP to remediate	1	4	

The data available, therefore, indicate the potential for a long-term indoor impact, that the migrating groundwater plume is likely the source of contaminated soil gases in and around the buildings, soil gas intrusion is likely the only significant impact route in most buildings, and that volatile chemicals in the well water are likely of concern in a few homes.

Based on a previous risk analysis, a mitigation level objective for indoor air concentrations of TCE of no more than 5 ppb/v, annual average may be established. This requires 90 to 95 percent reduction from current levels.

3.2.2 Building Structural Features

Basic information relative to the construction characteristics of the subject building should be gathered. The following building characteristics should be determined:

- The presence of a sub-structure drainage system indicates a potential for application of a drain tile ventilation system. Indications that a drain tile network exists are a basement sump, a dry well, and a remote above ground discharge pipe.
- The type of sub-structure should be noted to indicate if using a sub-slab ventilation system is feasible. The presence of a crawl space with an earth floor may indicate use of crawl space ventilation or sub-enclosure ventilation.
- The composition of the sub-slab region should be determined. The presence and depth of a sub-slab aggregate layer, a moisture barrier, and the porosity of the fill material will indicate the permeability of the materials and the potential for success of a sub-slab ventilation system. Diagnostics could be used to conduct sub-slab communication tests to physically assess the flow potential of the sub-slab. These tests should be conducted by an experienced diagnostician for reliable results.

The checked controls represent the minimum number of technical controls that could be used for all objectives which have a possible technical solution. ICs must now be selected for objectives for which there is no technical control or for which the technical controls will not satisfy the objective. The process for making these selections is the same as described under Strategy 1. After the ICs are selected, Strategy 3 is complete. It is composed of the minimum number of different technical controls, without considering their effectiveness, which can be applied to the most objectives and the minimum level ICs necessary to supplement the technical controls for each objective that could be used for mitigation.

3.4.1 Example - Strategy 3, "Least Technical"

The technical control with the highest frequency (2) is sub-slab ventilation. For the first and last objectives, which have multiple technical controls with frequencies of 1, only the highest rated controls were checked.

ICs are now chosen to supplement the technical controls. For preventing use of well water, using local health department restrictions is chosen to supplement the technical control. Because, in this case, it is believed that sub-slab ventilation is adequate for control of soil gas intrusion into the condos, no supplemental IC is chosen. For reducing soil gas intrusion into the single-family houses, the low rating suggests that sub-slab ventilation may be inadequate. Therefore, a strong IC, the only one listed in this example, was selected as a supplement. Again, the use of the local building permit process is chosen to prevent inappropriate construction and a consent agreement with the PRP is chosen to supplement the pump and treat technical control. The strategy alternative is shown in Table 3.6.

floors. Floors of all buildings are at grade level. The condominiums have a drain tile (French) system completely around the exterior perimeter. The building plans, and on-site inspection, indicate a 4-inch layer of pea gravel was placed under the slab floor. Foundation walls are constructed of hollow cinder block. Exterior frame walls are supported by a sill plate which rests on the top course of block. There is brick veneer on the exterior. There is a solid block wall between units. Utility connections (water, sewer, and electrical) penetrate both the slab and walls. Heating and cooling is all electrically-operated forced air. The buildings are well insulated and have a low air infiltration rate. All buildings are connected to the public water supply.

Structural information for the condominiums is useful for preliminary assessments of potential soil gas entry locations and possible mitigation techniques that could be used. The presence of a French drain suggests the possible presence of a designed gap between the slab and walls through which soil gas can enter. The hollow cinder block walls also can provide a pathway for soil gas to enter the building either through unsealed penetrations (e.g., utilities) or at the wall/sill plate junction. The opening between the brick veneer and the framing materials also can provide a pathway for soil gas to enter the building above the sill plate. The presence of a good layer of gravel beneath the slab indicates this area is probably highly porous and soil gases could probably be ventilated using a limited number of sub-slab ventilation points or by depressurizing the French drain system (assuming it is not plugged). The fact that the condos use electric heating and cooling indicates that 1) operation of the system probably has little effect on building pressures, and 2) backdrafting of furnace combustion products is not a concern if exhaust fan assisted soil ventilation methods are used.

There are ten single-family residences located in a heavily forested section of the community. All have poured concrete slab and foundation walls. There are indications that gravel was not used below the slab and that it was poured directly on the ground. Above grade construction is frame with brick veneer finish. Construction technique suggests air infil-

Strategy 4 - Most ICs"

Illustrated in Figure 3-5 is the process for developing strategy alternative 4 which is discussed below.

- Use a copy of the Master Matrix.
- In the third column (Institutional Controls), for each objective for which an IC is given, place a check mark by the control with the highest effectiveness rating for that objective.
- If purchase of the property is the highest rated, also place a check by the second highest rated IC. The objective here is to try to ensure the strategy does not default to a "purchase the property" option.
- Place a flag by all occurrences of the checked controls.
- Delete all unchecked and unflagged ICs.
- Note that if two or more controls have the same highest effectiveness rating for an objective or if property purchase was checked, additional "Strategy 4" options can be developed by using each of the checked controls sequentially.

At this point, the best IC for each objective, even if it is a poor control, has been selected. Also shown are the ICs selected for other objectives which supplement the effectiveness of the selected IC for each objective. Make a copy for use in developing Strategy 5.

Technical controls must now be chosen to supplement those institutional controls that would not satisfy the objectives.

- Begin with any objective for which there is no IC or for which property purchase was the only IC checked.

3.2.3 Example - Reducing Current and Future Impacts

Only 20 percent of the land immediately above the present position of the contaminated plume has been developed. It is composed of moderate to high density residential. Another 20 percent of the land is currently zoned for high density residential. The remaining land is currently zoned for light industrial. Land in the projected path of the plume is undeveloped but zoned for residential use.

Base on the information available, the following additional objectives were established to approach the mitigation level objective:

Objectives for Reducing Impacts to Current buildings

- *Prevent indoor usage of well water*
- *Reduce exposure to soil gas intrusion into existing buildings*

Objectives for Reducing Impacts from Future Development

- *Prevent the use of inappropriate construction methods*
- *Reduce contaminant concentrations in groundwater*

3.3 EVALUATION OF OPTIONS

With objectives defined and the exact nature of the problem delineated, the technical and institutional control measures that are applicable to mitigating the impacts can be evaluated. The procedures in this Section are oriented toward estimating the potential effectiveness of individual measures in mitigation. Combining these into workable alternative strategies is discussed in Section 3.4.

3.3.1 Estimated Effectiveness of Potential Technical Measures

Technical alternatives will be evaluated either in the process of planning a removal or in selecting a remedy or both. In either case the likely effectiveness of the alternative is a key consideration. The design and installation of the technical mitigation measures requires considerable technical expertise and experience. The EPA has provided technical guidance for design and installation of radon mitigation measures, and there is limited additional information available to assist in the mitigation of other indoor air contaminants.

- Place a check by the lowest effectiveness rated technical control that will, at the least, ensure that the objective is satisfied without relying on property purchase as an IC.
- Repeat until all objectives which have no institutional control or property purchase as the only IC are satisfied.
- For objectives which have only property purchase and one additional IC, select a technical control to supplement the secondary IC, if necessary.
- For all other objectives, review the effectiveness of the checked control plus the effectiveness of any supplemental controls (those selected for other objectives that also appear for this objective) and determine if the combined effectiveness will satisfy the objective. If they will not, a technical control must be selected.
- Place a check by the lowest effectiveness rated technical control that will, at the least, ensure that the combination of technical and institutional controls satisfy the objective. It is likely that those objectives for which the better institutional controls were selected, will not require supplemental technical controls.
- Delete all technical controls that were not checked or flagged for at least one of the objectives.

Strategy 4 is now complete. It is composed of the best institutional control, even though the control may be poor, for each objective and the minimum level technical control necessary to supplement the ICs for each objective, that could be used to effect mitigation.

3.4.1 Example - Strategy 4, "Most ICs"

The first step is to place checks by the highest rated institutional controls. This IC is property purchase for all except the last objective.

Therefore, a secondary IC is selected where possible; no alternative IC is given for reducing soil gas exposures. Using local health department restrictions is checked as the secondary IC for preventing use of well water and using the local building permit process is chosen as the secondary IC for preventing inappropriate construction.

The next step is to select technical controls for objectives with no ICs or those with property purchase as the only IC. In these cases the technical controls must be adequate to meet the mitigation objective without regard to the IC. Technical controls are needed to reduce soil gas intrusion in all occupied buildings. Modifying the ventilation, which will include sealing of major entry routes, is selected for the detached houses. Sub-slab ventilation is selected for the condominiums. Following the instructions, this control is also flagged for the single-family houses. However, it will not provide supplemental control in this case because the control is not applied to the same intrusion route.

Next, technical controls are selected to supplement the secondary IC for those objectives with property purchase as the primary IC. An alternative water supply is needed to supplement the health department restrictions on well usage. For reducing groundwater contaminant concentrations, it is assumed, in this case, that the consent agreement with the PRP is adequate and no supplemental technical controls are needed.

The completed matrix is shown in Table 3.7. Based on the controls selected, there are two possible Strategy 4's; one based on purchasing the property and holding it until the groundwater is cleaned-up sufficiently that indoor air impacts are not of concern, and one based on using the second highest rated ICs supplemented by providing an alternate water source for single-family homes, installing sub-slab ventilation for the condominiums, and modifying the ventilation in the single-family homes.

Strategy 5 - Best ICs"

Illustrated in Figure 3-6 is the process for developing strategy alternative 5 which is discussed below.

Table 3.7 Strategy 4 Matrix Table

Objectives	Technical Controls			Institutional Controls			Probable Cost
	Control	Freq.	Rating	Control	Freq.	Rating	
Prevent use of well water	Alternate water source	1	45	Buy the properties Use Local health department restrictions	4 1	5 3	
Reduce exposure to soil gas intrusion into condos	Sub-slab ventilation	2	48	Buy the property	4	5	
Reduce exposure to soil gas in single-family houses	Sub-slab ventilation Modify ventilation	2 1	16 36✓	Buy the property	4	5	
Prevent use of inappropriate construction methods	None			Buy the properties Use local building permit process	4 1	5 3	
Reduce contaminant concentrations in groundwater	Pump and treat in community	1	24	Consent agreement with PRP to remediate	1	4	

- Use the copy made while developing ICs for Strategy 4.
- Review the checked institutional controls only and mark through all except those with the two highest effectiveness ratings. If no institutional controls were deleted, Strategies 4 and 5 will be identical and there is no need to proceed with this strategy.

Technical controls must now be selected for objectives for which there is no IC or for which the ICs will not satisfy the objective. The process for making these selections is the same as described under Strategy 4. After the technical controls are selected, Strategy 5 is complete. It is composed of institutional controls with the two highest effectiveness ratings and the minimum level technical controls necessary to supplement the ICs for each objective, that could be used to effect mitigation.

3.4.1 Example - Strategy 5, "Best ICs"

In this case, property purchase is checked by all objectives except reducing contaminant concentrations in groundwater. A consent agreement with the PRP is the IC for this objective. Technical controls must be selected to supplement the ICs. First, technical controls are examined for objectives having only property purchase as an IC to determine if any would be adequate without the IC. For preventing use of well water, it is assumed that simply providing an alternate water source without some control in place to prevent continued use of the existing well systems would be inadequate. Therefore, on technical control is chosen for this objective. For the condominiums, it is assumed that sub-slab ventilation would adequately control the soil gas intrusion and it is chosen as a stand alone control. None of the technical controls are considered adequate as stand alone methods for preventing soil gas intrusion into the single-family homes and there is no technical control given for preventing inappropriate construction. For this case, it will be assumed that the consent agreement with the PRP is adequate and no supplemental technical control is needed. The strategy alternative, shown in Table 3.8, would comprise purchasing all the developed and undeveloped impacted properties and requiring the PRP to cleanup the groundwater. It is apparent that this

Select Institutional Controls

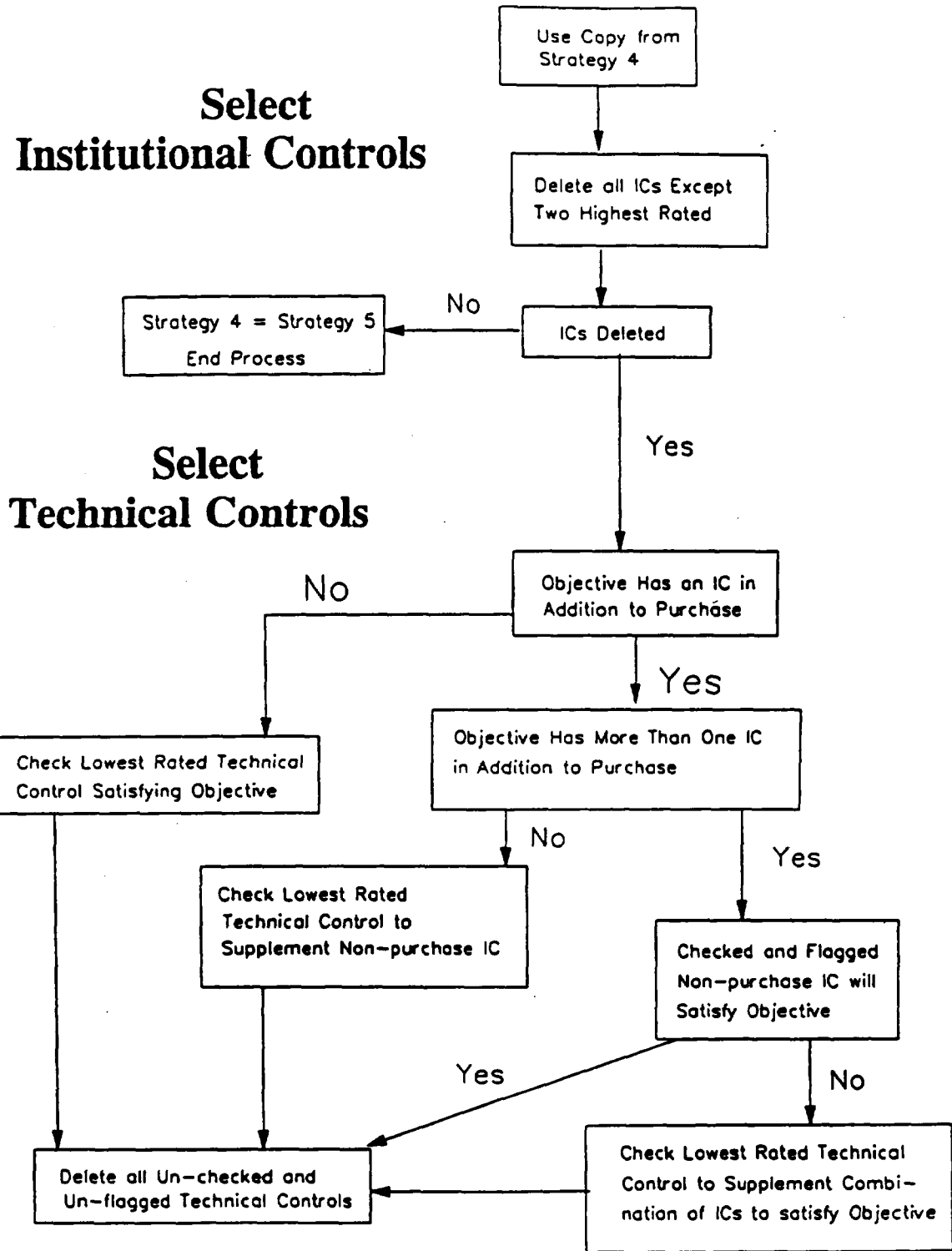

Figure 3-6. STRATEGY 5 - BEST ICs

Table 3.8 Strategy 5 Matrix Table

Objectives	Technical Controls			Institutional Controls			Probable Cost
	Control	Freq.	Rating	Control	Freq.	Rating	
Prevent use of well water				Buy the properties	4	5	
Reduce exposure to soil gas intrusion into condos				Buy the property	4	5	
Reduce exposure to soil gas in single-family houses				Buy the property	4	5	
Prevent use of inappropriate construction methods				Buy the properties	4	5	
Reduce contaminant concentrations in groundwater				Consent agreement with PRP to remediate	1	4	

would be an expensive alternative and may likely be eliminated without further consideration.

At this point, a number of strategies have been developed that should be effective in mitigating the indoor air impacts. These will need to be compared using the NCP evaluation criteria (EPA88b) to determine which strategy will be recommended for implementation. In principle, all of the strategies, as a subpart of overall site remediation efforts, should be effective.

3.4.2 Probable Costs to Implement and Operate

Costs should be considered in terms of the costs to implement the remedy, the costs to operate and maintain the systems, and the length of time that the systems must remain effective. Ranges for installation and operating cost were given in Section 2 for a number of technical mitigation measures. These costs are based on radon mitigation experience. It should be taken into account that cost may rise substantially if more sophisticated equipment is used. For example, when mitigating for high levels of methane or other combustible gases, explosion proof installation may be required for electrical systems, fan motors, etc. Likewise, installation of systems with backup power systems, monitors, or alarms will also increase costs.

The time the remedy must remain in place should be considered in determining how a particular technical method will be implemented. Note that the technical methods in the strategies developed above may be accomplished using different types of equipment and installation methods. Various tradeoffs should be considered in estimating the costs involved.

For short-term requirements, these tradeoffs might include selecting less durable, and thus cheaper, equipment. In these cases, the costs of replacing components, both time and materials, should be considered in determining the total costs over the time period.

In general, as the length of time that the method must be in place increases, the more reliable and aesthetically appealing the installation should become. This invariably leads to higher initial costs which may be offset to some extent by lower operating, including maintenance, costs.

The costs of implementing ICs must also be considered. In addition to the actual compensation paid, when necessary, cost may also include recording fees and other legal fees. In many cases, EPA contracts for many of the legal services needed. Because State laws are quite variable, the costs of implementing identical ICs in different areas may deviate considerably. It is recommended that Regional Counsel be consulted for assistance.

The costs of ensuring that some ICs remain effective for the required period may be affected by the time period required. For example, ICs based on contractual agreements, such as restrictive covenants, may vary in the amount of legal effort required depending on the time the covenant must be effective. If only short-term effectiveness is required, and conveyance is not an issue, less extensive legal work may be adequate. However, as the effectiveness time increases, additional effort may be required to ensure future owners would be bound by the agreement.

3.4.2 Example - Probable Cost to Implement and Operate

In the example used, for prevention of use of well water all strategies rely on either purchase of the 10 homes using well water or providing an alternate water source and using health department restrictions to ensure use of existing wells does not continue. Because public water is already available in the community, connecting the 10 homes to this supply would likely be the least expensive option.

For reducing soil gas intrusion into existing buildings, several types of technical controls are considered. Institutional controls range from none, to purchasing single-family homes only, to purchasing all existing homes. Because drain tiles are already in place for the condominiums,

active ventilation of the tiles would be fairly inexpensive. Drain tile ventilation would be cheaper than sub-slab ventilation, primarily because less remodeling of the highly finished lower floors would be needed. For single-family homes, drain tile ventilation is not a possibility and sub-slab ventilation is questionable due to the high likelihood of poor under slab permeability. If sub-slab ventilation were used, it is likely the costs would be high because all lower levels are highly finished and many suction points may have to be used. Because the slab floor and foundation wall are poured concrete, it is possible that sealing major opening and modifying the building ventilation would be both effective and relatively inexpensive. Ventilation improvements would probably include providing outdoor air as combustion air for the oil furnaces to reduce depressurization, and increasing the proportion of return air that is supplied to the lower floor to increase pressure on that level.

For preventing inappropriate new construction techniques, no technical controls are available and institutional controls are either using restrictions available through local building codes or purchase of the property. Using the building code restrictions would appear to be significantly less expensive and more easily implementable.

Reducing contaminant concentrations in the groundwater is part of the overall site remediation plan. The need to reduce indoor air impacts becomes part of the input to remediation goals. Cost would not be a consideration for mitigating indoor air impacts unless the indoor impact risks drive the groundwater remediation levels required.

REFERENCES FOR SECTION 3

- EPA88a Radon Reduction Techniques for Detached Houses: Technical Guidance. Second Edition, EPA/625/5-87/019, January 1988.
- EPA88b Guidance for Conducting Remedial Investigations and Feasibility Studies Under CERCLA. EPA/540/G-89/004, OSWER Directive 9355.3-01, October 1988.
- EPA89 Risk Assessment Guidance for Superfund: Volume 1 - Human Health Evaluation Manual (Part A). EPA/540/1-89/002, December 1989.
- EPA91 Risk Assessment Guidance for Superfund: Volume 1- Human Health Evaluation Manual (Part B, Development of Risk Based Preliminary Remediation Goals). Publication 9285.7-01B, October 1991.
- EPA92 Assessing Potential Indoor Air Impacts for Superfund Sites. EPA-451/R-92-002, October, 1992.

SECTION 4 EVALUATING A PROPOSED MITIGATION STRATEGY

This Section discusses general procedures that could be used in conducting a screening review of indoor air mitigation strategies that have been proposed. This is not general guidance for the screening analysis; rather, it represents a process that may be a useful tool for conducting such an analysis. The review is useful as part of the alternatives screening process described in section 430(e)(7) of the NCP. The procedures in this section do not include, nor do they substitute for, the detailed evaluation of alternatives required for remedy selection. Note - the screening referred to here is only a preliminary screening to eliminate alternatives that are significantly less effective, infeasible, or grossly excessive in cost. The procedures in this section assume that the reviewer was not involved in the development of the indoor air mitigation part of the alternatives being considered. The procedures, however, may also be of benefit in reviewing mitigation strategies under development.

4.1 OBJECTIVE OF EVALUATION

The objective of this screening evaluation is to determine which alternatives are adequate to proceed to detailed evaluation. Comparisons made during screening are generally made between similar alternatives with only the most promising carried forward for further analysis. As indicated in Section 3, the NCP requires that defined alternatives be evaluated against the short- and long-term aspects of effectiveness, implementability, and costs. The objective of Section 4 is to assist the reviewer in addressing these objectives and to provide procedures to ensure specific concerns relevant to the indoor air impacts are considered.

4.2 REVIEW SITE RELATED INFORMATION

Any review of a proposed strategy should begin with a review of the information about the site. The purpose of this review is to determine if

all pertinent information regarding the site was considered. The purpose is also to determine if the information relevant to the site impacts and their possible mitigation approaches were properly assessed. Most relevant to this review are the contaminant source type(s) and strength(s), the route(s) of potential impacts, and the estimated duration of those impacts.

4.2.1 Contaminant Source and Route of Impact

The background information for the site should first be compared with information from site investigation reports. The objective is to check for consistency and completeness. The easiest way to conduct this check is to prepare a list during review of the information detailing the types of contaminants cited, the amounts or concentrations in the various media, the area and depth of those contaminations, and the pathways for pollutant transport off-site and to receptors. This information should then be compared with site investigation reports to determine its consistency. Information which is inconsistent should be flagged.

Pollutants and their potential pathways listed in the site investigation reports, but not in the proposed strategy background information, should be noted. Any additional pathways for pollutants listed in the strategy should also be noted. These pollutants and their pathways should be evaluated to determine if additional impacts not considered previously may be present. This is an important step because it is possible that the strategy may have been developed solely on documented current indoor air impacts and not considered additional potential future impacts.

4.2.2 Duration of Impacts

Duration of impacts is a significant driver for mitigation method selection. Therefore, it is important that the proposed strategy has taken duration properly into account. The duration of indoor air impacts given in the proposed strategy should be compared to the time estimated for completion of remedial actions which treat or remove the contaminants responsible for the impacts. A similar comparison should be performed regarding the time estimated for residual pollutants, impacting on-site and off-site receptors, to remain at the site.

4.2.3 Comparison of Site Information to the Strategy

The proposed strategy should be reviewed to determine whether or not the information developed during the review of background information per Section 4.2.1 has been considered. Note that, at this point, the review is only to determine if all potential pollutants and pathways have been addressed for the appropriate time frames. The likely effectiveness of those measures proposed by the strategy will be reviewed in Section 4.4.

Using the information developed above, prepare a table giving, in the first column, a list of all impact pathways, the expected duration of impacts by this pathway, and the pollutants potentially impacting through those pathways (i.e., those included in the proposed strategy and those added by the reviewer). Pathways and pollutants added by the reviewer (i.e., those potentially missed during strategy development) should be distinguishable, perhaps by using different color writing, from those in the proposed strategy. Review the various technical and institutional controls utilized in the strategy and list them individually across the top as headings for each additional column. Table 4.1 shows the general appearance such a table would have. Individual technical and institutional controls would be entered as headings for the columns under "Proposed Technical and Institutional Controls".

Beginning in column 2, place a check by each pathway to which that control method is applicable and the pollutant(s) it is expected to control to some degree (should be stated in the proposed strategy). The reviewer should also place a different mark in this column, such as an asterisk, by each pollutant in column 1 the reviewer has reason to believe would also be controlled by this method. Complete the table for all proposed control methods. Place a flag, such as a red "x", in column 1 by any pathway, or pollutant listed for a pathway, not addressed by at least one control method. Use a different kind of flag to indicate pathways included in the proposed strategy for which there is no supporting evidence in the site investigation reports.

Table 4.1 Example Format for Comparison of Site Information

Impact Pathways	Proposed Technical and Institutional Controls			
	Control 1	Control 2	Control 3	Control 4
Ambient Air Duration Pollutant A Pollutant B				
Soil Gas Duration Pollutant A Pollutant B				
Groundwater Duration Pollutant A Pollutant B				

The consistency and completeness check for inclusion of source information is now complete. It indicates whether or not all appropriate pathways and pollutants have been considered. It does not indicate the controls are adequate for the mitigation.

4.2 EXAMPLE REVIEW SITE RELATED INFORMATION

The Strategy 1 alternative presented in Section 3 will be used for the example application of the methods described in this Section. It will be assumed that only the information given in that Section was provided to the reviewer. Information in that Section should be consulted as necessary.

The first step is to create the review table (see Table 4.1 and Table 3.4). The completed table is shown as Table 4.2. Begin by reviewing the information provided for the source of the contamination in Table 3.4 such as pollutants, amounts, area/volume contaminated, and transport pathways. The proposed strategy mentions only one pollutant, TCE. However, the source was identified as a storage tank for a manufacturing facility, and based on the groundwater migration rate, 0.5 ft/d, and the extent of contamination, pollutant found 1,200 yds from the tank, it is likely the

release has been occurring for at least 20 years. It is likely, therefore, that other pollutants, either from material stored in the tank over 20 years or degradation of the TCE in the groundwater, should have been found. Analytical data from the monitoring conducted should be obtained and reviewed. In Table 4.2, additional pollutants are listed as Pollutant B. The duration expected was determined from remediation plans for the site. These plans indicated site remediation would take no more than 10 years.

The proposed strategy indicated monitoring was done in fall and winter and that only low concentrations of TCE were detected in the ambient air. The ambient air pathway was not considered further. As no information was provided regarding potential changes in the depth of the water table, due to snow melt or spring rains, and the effect that might have on surface emissions, this pathway for pollutants released into the air near the buildings and possibly drawn into the indoor environment may have been incorrectly discounted. Additional information on variations in water table depth are needed. Monitoring or modeling may be needed to estimate the importance of this pathway. This additional potential pathway was added to the table.

Soil gas intrusion and indoor uses of the contaminated groundwater were pathways given in the strategy. Because other pollutants besides TCE are expected, a "Pollutant B" was added to each pathway.

The proposed technical and institutional controls given in Table 3.4 are listed across the top of the table. For ambient air impacts (soil gas rising to surface near the building), it is likely that the "Pump and Treat" and "Consent Agreement" controls would reduce the indoor air impacts. Therefore, a check is placed by TCE, listed in the strategy, and an asterisk by Pollutant B, added by the reviewer. None of the other controls are expected to reduce the ambient air impact.

For the soil gas intrusion pathway, check marks are placed by 5 of the controls. The first two are technical controls that work to prevent soil gas entry into existing buildings. The "Building Restriction" control

works to prevent entry into any additional buildings constructed. The remaining two controls, "Pump and Treat" and "Consent Agreement", work to reduce the contaminant concentration in the groundwater and, thus, the potential for impact by any pathway.

For the indoor use of groundwater pathway, 5 controls work to reduce or prevent impact from use of groundwater. These range from stopping current usage to ensuring clean water is used for new construction to remediating the groundwater in order that unrestricted usage may occur.

4.3 REVIEW IMPACTED STRUCTURE/AREA INFORMATION

A critical review of information presented for the impacted area and structures involved should be conducted. The presumption should be that the strategy proposed is based solely on information in the documentation provided to the reviewer supporting that strategy. It is important, therefore, to assess whether or not all appropriate issues were addressed and whether or not the information is consistent with information developed during the assessment phase of the investigation. Review will be most easily accomplished if a table is prepared similar to that developed in Section 4.2. Place in column 1 the review areas listed below, leaving space under each for sub-issues. Significant areas for review to be included in the table are the expected duration of impacts, the developmental status of the affected area, current uses, intended future uses, pollutant levels measured or estimated for existing structures, pollutant levels estimated for future development, and structural characteristics of the soil and buildings. See Table 4.3.

Table 4.2 Example Review of Site Information

Impact Pathways	Proposed Technical and Institutional Controls						
	Alternate Water Source	Drain Tile Ventilation	Modify Ventilation	Pump and Treat	Well Use Restriction	Building Restriction	Consent Agreement
Ambient Air Duration - 10 yrs Pollutant - TCE Pollutant B				✓ *			✓ *
Soil Gas Duration - 10 yrs Pollutant - TCE Pollutant B		✓ *	✓ *	✓ *		✓ *	✓ *
Indoor Use of Groundwater Duration - 10 yrs Pollutant - TCE Pollutant B	✓ *			✓ *	✓ *	✓ *	✓ *

Table 4.3 Example Format for Reviewing Impacted Structure/Area Information

Review Areas	Proposed Technical and Institutional Controls			
	Control 1	Control 2	Control 3	Control 4
Duration				
Development Status				
Current Uses				
Intended Future Uses				
Pollutant Levels, Current				
Pollutant Levels, Future				
Structural Information				

4.3.1 Developed vs Undeveloped Land

Using information from site investigations, indoor air impact assessments, and the proposed strategy, determine if the impacted area is developed or undeveloped. Strategies proposed for developed areas may rely heavily on technical controls for specific properties whereas strategies for undeveloped areas may rely on source control and institutional controls.

Strategies for developed areas may address only those properties known to be currently impacted. If the expected duration of impacts is short as a result of site remediation efforts or other factors which will reduce pollutant concentrations in the affected area and little or no additional development is expected in this time frame, such a strategy may be acceptable. However, if similar or greater impacts are expected to occur for several years, the strategy should address mitigation of potential new structures.

4.3.2 Current and Intended Future Uses

The proposed strategy should state the current uses of the impacted area. Current usage information should include whether the area is used for heavy or light industrial, commercial office buildings, high density residential, single-family detached housing, and schools. It should indicate whether the area is urban or rural, or other information to indicate population density. If mitigation is proposed for only a small number of structures, the strategy should indicate the current usage of those structures.

If adverse impacts for the area are projected to continue for several years, the proposed strategy should include a discussion of intended future uses.

4.3.3 Measured and Estimated Level of Impact

The proposed strategy and supporting impact assessment information should be compared to determine if measured and estimated impact levels are consistent. In this section of the table being created, list the pollutants contained in the table created in Section 4.2 above (Table 4.1). Beside each, insert information given in the proposed strategy for the measured or estimated indoor air concentration of that pollutant which is attributed to impacts from the site. If no concentration data are given for a pollutant, insert an "N" in this space. Compare these to the concentrations given in the indoor air impact assessment document. Place a check by those that are in substantial agreement, a question mark by those in significant disagreement, and an "x" by any of the pollutants not listed in the assessment document.

4.3.4 Structural Characteristics

The strategy should be reviewed to determine if the characteristics of structures for which mitigation is proposed have been adequately addressed. For cases in which future development must also be considered, the assumed characteristics of those structures should be reviewed.

Structural characteristics are most important when the impact pathway is by intrusion of groundwater or soil gases. In these cases, the construction details must be reasonably well described to provide the basis for an adequate review of the applicability of mitigation techniques. The basic information that should be addressed in the proposed strategy or supporting assessment document include (adapted from EPA88b):

General

- Type of building construction; brick, frame, etc,
- Building shell leakage; leaky, moderate, tight,
- Building exposure; open terrain, nearby woods or buildings, heavily forested,
- Water source; private well or off-site supply,
- Substructure type; full slab on grade, full crawl space, full basement, or combination of above,
- Evidence of moisture problems; water marks, mold or mildew,
- Vented combustion devices; fireplace, oil or gas furnace,
- Evidence of asbestos-containing materials

Floor in contact with ground

- Depth/height of floor below/above grade,
- Material; open soil, poured concrete, block, brick, stone,
- Drains; floor drain, French drain, weeping tile system beneath floor, connect to sump septic tank or sewer,
- Soil beneath floor; gravel (4 to 6 inches), soil permeability,
- Floor joint to wall; length and width of crack, type of sealing material,
- Floor condition; utility openings, floor cracks,
- Floor covering; unfinished, carpeted, etc.,

Walls connecting with floor in contact with ground

- Depth/height below/above grade,
- Material; poured concrete, solid block, hollow block (top blocks filled or solid?), hollow block with plenums concrete filled, other,
- Wall condition; utility openings, vents, windows, cracks,

- Wall covering; unfinished, partially finished, fully finished as living area.

Assumptions made for new construction in currently developed areas or in undeveloped areas should be reviewed to determine if they are in general agreement with normal construction practices for the area. Assumptions made based on significantly more expensive construction techniques should be flagged for comparison with any proposed institutional control that might require such construction.

4.3.5 Proposed Technical and Institutional Controls

Complete the table under development by listing the various technical and institutional controls utilized in the strategy individually across the top as headings for each additional column. Beginning in column 2, place a check by each item of column 1 which is addressed for that control method in the proposed strategy. The reviewer should also place a different mark in this column, such as an asterisk, by each item of column 1 the reviewer has reason to believe would also be addressed by this method. Complete the table for all proposed control methods. Place a flag, such as a red "x", in column 1 by any item not addressed by at least one control method. This would also include pathways or pollutants added by the reviewer and potentially overlooked during strategy development. Use a different kind of flag to indicate which, if any, of the items in column 1 lack adequate documentation to justify their inclusion in the strategy.

4.3.6 Completion of Review

The consistency and completeness check for inclusion of information for the impacted area is now complete. It indicates whether or not all appropriate items have been considered. It does not indicate that the controls are adequate for the mitigation. If there are significant data gaps, the reviewer should obtain missing information deemed necessary to complete the review.

4.3 EXAMPLE REVIEW IMPACTED STRUCTURE/AREA INFORMATION

Information related to the impacted area may be reviewed by developing the information suggested by Table 4.3. In table 4.4, information from the strategy description (see Section 3) is included in the Review Areas column. In an actual case, more information, as discussed in the preceding sections, would be included for pollutants and for structural details. The technical and institutional controls from Strategy 1 are listed across the top as column headings. The "N's" are placed by the pollutants for both current and future concentrations indicating that the discussion in Section 3 did not give actual or estimated indoor pollutant concentrations. Concentration data are needed for both condominiums and single-family homes to assess whether the 90 to 95 percent reduction objective given is realistic.

For current purposes, the discussion provided in Section 3 for the proposed strategy adequately addressed the developmental status and the likely future uses of the property, developed and undeveloped. All of the structural information requested by Section 4.3.4 was included and addressed in the strategy except that pertaining to asbestos, floor cracks, and the utility room drain to the septic system for the single-family homes. Asbestos is unlikely in the construction described. Because the lower floors of the buildings are fully finished, floor cracks probably cannot be fully assessed until mitigation begins. However, because French drains, hollow block walls, a sill plate, and a brick veneer were used in the condominiums, all of which provide excellent pathways for intrusion of soil gases, cracks are a minor issue at this stage.

In each of the columns, checks are placed by each review item addressed by the particular control. Asterisks are placed by review items added during the previous review step to which the control is also applicable. The effect of the "Alternate Water Source" control is primarily on current homes and checks are placed by 5 items, all related to current single-family homes, and one item for future impacts. The latter is added because installing the alternative water system to the single-family homes provides an in-place system to service some new or modified construction.

For "Drain Tile Ventilation", additional checks are placed by several structural items because these items were specifically considered in selecting this control for the Strategy 1 alternative. Checks are placed by all items for "Building Restrictions" except for current concentrations of indoor air pollutants. Note that checks are also placed by current uses because the building restrictions would apply to any modifications to existing structures. This is the only control that addresses soil gas intrusion from the septic systems through the floor drains and then only for new/modified construction. The strategy did not specifically address mitigation of current structures for this potential soil gas intrusion through the floor drain, the trap of which likely is not consistently water filled. This can be a major entry route and must be addressed.

4.4 REVIEW PROPOSED MITIGATION STRATEGY TECHNIQUES

Assuming the necessary information has been obtained, the reviewer should proceed with assessing whether or not the proposed strategy is likely to satisfy the mitigation requirements. Elements of this review which are discussed below are:

- comparing the strategy to those successfully used in previous cases,
- modifications of prior successful strategies needed to satisfy the specific case,
- reasonableness of control effectiveness estimates,
- reasonableness of cost estimates,
- enforceability of institutional controls proposed.

4.4.1 Comparability to Strategies Used in Similar Cases

Confidence in a proposed strategy is increased if it uses similar mitigation methods to those that have been successful in comparable cases. There are only a limited number of implemented indoor air impact mitigation strategies at CERCLA sites at which EPA was the lead Agency. Although

Table 4.4 Example Reviewing Impacted Structure/Area Information

Review Areas	Proposed Technical and Institutional Controls						
	Alternate Water Source	Drain Tile Ventilation	Modify Ventilation	Pump and Treat	Well Use Restriction	Building Restriction	Consent Agreement
Duration - 10 yrs	✓	✓	✓	✓	✓	✓	✓
Develop. Status Developed	✓	✓	✓	✓	✓	✓	✓
Undeveloped				✓		✓	✓
Current Uses Single-family	✓		✓	✓	✓	✓	✓
High Dens. Res.		✓		✓	✓	✓	✓
Undeveloped				✓	✓	✓	✓
Intended Future Uses Residential				✓	✓	✓	✓
Current Concentration TCE N	✓	✓	✓		✓		
Pollutant B N	*	*	*		*		
Future Concentration TCE N	✓	✓	✓	✓	✓	✓	✓
Pollutant B N	*	*	*	*	*	*	*
Structural Frame			✓	✓			
Normal Leaks		✓	✓	✓		✓	
Private Wells	✓			✓	✓	✓	
Slab-on-grade		✓	✓	✓		✓	
Oil Furnace		✓	✓	✓		✓	
Concrete Floor		✓	✓	✓		✓	
Floor Drains				✓		✓	

confidence will not be as high for proposed strategies not using those control methods, they should not necessarily be discarded. Performance information for the control methods, as discussed in Sections 4.4.2 and 4.4.3 below, may be useful for assessing their applicability in specific cases. Performance information is also indicated in the case examples in the Appendix.

Information about the performance of indoor air impact mitigation strategies may also be available for sites at which a State Agency had the lead. Performance information may also be available for Radon program activities and RCRA program cleanups.

4.4.2 Applicable to Specific Case

Using the information developed in Sections 4.2 and 4.3, information contained in the proposed strategy document, and other technical information such as that in Section 2, the reviewer can assess the applicability of each control proposed to the particulars of the specific case. Information in the proposal on the applicability of the method and its limitations should be reviewed and compared to the site specific information developed in Tables 4.2 and 4.4. For each control method on these tables, review the information provided to determine if the method is applicable to the items checked. Look particularly for items that may be major impediments. For example, drain tiles blocked with water during wet weather are a major impediment to drain tile ventilation. If major defects are found, the strategy should be eliminated from those that will be subjected to detailed evaluation for selection of the remedy.

If no major defects are found, the reviewer should consider the methods being proposed to mitigate a specific type of impact, such as use of contaminated groundwater, as a group. Attention should be given to any group of methods that rely on several substantially similar techniques to effect incremental control as this may be an unreliable approach. Attention should also be given to groups that contain a large number of different techniques for the control of a type of impact. This may indicate that the strategy proposed is more conservative than necessary.

4.4.3 Reduction Estimates Reasonable

Estimates of indoor contaminant reductions for each specific type of indoor impact in the proposed strategy should be compared to known or estimated performance for the controls proposed. See Section 2. Most confidence in the reduction estimates occurs when only one or two control methods are responsible for most of the contaminant reduction and the estimated control effectiveness is less than the demonstrated performance in similar applications. Least confidence occurs when several methods, each with estimated effectiveness at the limit of demonstrated or theoretical performance, are proposed to control a single indoor impact pathway. Attention should be given to the methodology used to arrive at the overall control effectiveness estimated. In general, performance information is based on each control as the only one in use. The combined effectiveness for several controls based on similar techniques may be less than expected for simple addition of the effectiveness of individual controls.

The reviewer should tabulate the control effectiveness information in the proposed strategy for each specific type of indoor impact and compare it to the estimates developed during the review. Estimates substantially above or below those in the strategy should be flagged for additional review. All estimates should be compared to the objectives stated in the proposed strategy to determine if those objectives are met.

4.4.4 Cost Estimates Reasonable

Cost estimates in the proposed strategy should be compared to published ranges, or recent Agency experience, for installation and operation of the methods used. Regional counsel should be contacted to verify costs of implementing ICs unless concurrence of the counsel regarding costs is contained in the proposed strategy. Cost estimates should be examined to determine if they have been properly adjusted for the region of the country and escalated properly from the base year for which the cost were reported. Cost for post-mitigation diagnostics and costs for checks to verify technical and institutional controls remain effective should also be included.

Therefore, a secondary IC is selected where possible; no alternative IC is given for reducing soil gas exposures. Using local health department restrictions is checked as the secondary IC for preventing use of well water and using the local building permit process is chosen as the secondary IC for preventing inappropriate construction.

The next step is to select technical controls for objectives with no ICs or those with property purchase as the only IC. In these cases the technical controls must be adequate to meet the mitigation objective without regard to the IC. Technical controls are needed to reduce soil gas intrusion in all occupied buildings. Modifying the ventilation, which will include sealing of major entry routes, is selected for the detached houses. Sub-slab ventilation is selected for the condominiums. Following the instructions, this control is also flagged for the single-family houses. However, it will not provide supplemental control in this case because the control is not applied to the same intrusion route.

Next, technical controls are selected to supplement the secondary IC for those objectives with property purchase as the primary IC. An alternative water supply is needed to supplement the health department restrictions on well usage. For reducing groundwater contaminant concentrations, it is assumed, in this case, that the consent agreement with the PRP is adequate and no supplemental technical controls are needed.

The completed matrix is shown in Table 3.7. Based on the controls selected, there are two possible Strategy 4's; one based on purchasing the property and holding it until the groundwater is cleaned-up sufficiently that indoor air impacts are not of concern, and one based on using the second highest rated ICs supplemented by providing an alternate water source for single-family homes, installing sub-slab ventilation for the condominiums, and modifying the ventilation in the single-family homes.

Strategy 5 - Best ICs*

Illustrated in Figure 3-6 is the process for developing strategy alternative 5 which is discussed below.

Applicable to Specific Case -- The information provided indicates that site specific consideration have been taken into account. Specifically, the likely permeability of subsurface soils and building construction details were considered in selection of techniques for the alternative. No more than one technical control and one institutional control were given for control of any single objective. Thus, the alternative is likely not to be overly conservative. Thus, the reduction achieved should be similar to that achieved in prior applications.

Reduction Estimates Reasonable -- Although not specifically stated in the proposed strategy, all technical methods proposed have been shown, in similar or related applications, to equal or exceed the 90 to 95 percent reduction stated as the objective. And because no more than one technical control and one institutional control were given for control of any single objective, the reduction achieved should be similar to that achieved in prior applications.

Cost Estimates Reasonable -- The proposed strategy discusses likely costs in relative terms rather than specifics. There is no way to know from the discussion what the likely final cost would be.

Enforceability -- Enforceability of the ICs was not discussed. No information was given on assurances or binding agreements made to ensure these would not be changed. Considering the pressure to develop for this area, such assurances should be obtained or the ICs should be considered unreliable for the 10 year period proposed.

The strategy has several flaws, pointed out above, that should be addressed before the strategy is accepted as a potential remedial alternative. These include the ambient air pathway, soil gas intrusion through floor drains, and reliability of the ICs proposed.

- Use the copy made while developing ICs for Strategy 4.
- Review the checked institutional controls only and mark through all except those with the two highest effectiveness ratings. If no institutional controls were deleted, Strategies 4 and 5 will be identical and there is no need to proceed with this strategy.

Technical controls must now be selected for objectives for which there is no IC or for which the ICs will not satisfy the objective. The process for making these selections is the same as described under Strategy 4. After the technical controls are selected, Strategy 5 is complete. It is composed of institutional controls with the two highest effectiveness ratings and the minimum level technical controls necessary to supplement the ICs for each objective, that could be used to effect mitigation.

3.4.1 Example - Strategy 5, "Best ICs"

In this case, property purchase is checked by all objectives except reducing contaminant concentrations in groundwater. A consent agreement with the PRP is the IC for this objective. Technical controls must be selected to supplement the ICs. First, technical controls are examined for objectives having only property purchase as an IC to determine if any would be adequate without the IC. For preventing use of well water, it is assumed that simply providing an alternate water source without some control in place to prevent continued use of the existing well systems would be inadequate. Therefore, on technical control is chosen for this objective. For the condominiums, it is assumed that sub-slab ventilation would adequately control the soil gas intrusion and it is chosen as a stand alone control. None of the technical controls are considered adequate as stand alone methods for preventing soil gas intrusion into the single-family homes and there is no technical control given for preventing inappropriate construction. For this case, it will be assumed that the consent agreement with the PRP is adequate and no supplemental technical control is needed. The strategy alternative, shown in Table 3.8, would comprise purchasing all the developed and undeveloped impacted properties and requiring the PRP to cleanup the groundwater. It is apparent that this

Table 3.8 Strategy 5 Matrix Table

Objectives	Technical Controls			Institutional Controls			Probable Cost
	Control	Freq.	Rating	Control	Freq.	Rating	
Prevent use of well water				Buy the properties	4	5	
Reduce exposure to soil gas intrusion into condos				Buy the property	4	5	
Reduce exposure to soil gas in single-family houses				Buy the property	4	5	
Prevent use of inappropriate construction methods				Buy the properties	4	5	
Reduce contaminant concentrations in groundwater				Consent agreement with PRP to remediate	1	4	

The land adjacent to the landfill was initially undeveloped but zoned for residential. Development of the property was desirable. Local authorities were, however, concerned that some impacts from soil gas migration, due the presence of buried refuse, might occur in buildings constructed on the property. Therefore, an institutional control was utilized that worked through the building permit. Any developer of the property was required to remove any refuse buried beneath proposed building foundations and to install passive venting systems. A number of townhouse clusters were subsequently built in accordance with the institutional controls.

5.1 TECHNICAL EFFECTIVENESS

Quantitative testing of the building indoor air should be conducted to determine if the projected reduction in pollutant levels has been achieved. It is recommended that the monitoring methods and procedures described in "Assessing Potential Indoor Air Impacts for Superfund Sites", EPA 451/R-92-002, be used for this purpose. It should be noted, however, that procedures in that manual for estimating the intrusion of pollutants into the structure will likely not be applicable if soil gas ventilation systems have been installed. In these cases, sampling only the ambient and indoor air and comparing the results to premitigation concentration levels may provide a measure of the reduction achieved. Any sampling methodology used should be designed and implemented by qualified individuals.

Two types of monitoring may be required: direct indoor air pollutant measurements under existing conditions and diagnostic type testing to assess control probability under conditions less favorable to control techniques in place. Diagnostic testing may also be used to ensure the system is operating as intended and to find the cause of system failure so that corrective actions may be taken.

5.1.1 Direct Indoor Air Measurements

Comparison of short-term direct indoor air measurements to premitigation conditions can serve as an indicator of the level of mitigation achieved. However, because many variables may have changed, the reduction determined may not be completely attributable to the mitigation systems.

In general, as the length of time that the method must be in place increases, the more reliable and aesthetically appealing the installation should become. This invariably leads to higher initial costs which may be offset to some extent by lower operating, including maintenance, costs.

The costs of implementing ICs must also be considered. In addition to the actual compensation paid, when necessary, cost may also include recording fees and other legal fees. In many cases, EPA contracts for many of the legal services needed. Because State laws are quite variable, the costs of implementing identical ICs in different areas may deviate considerably. It is recommended that Regional Counsel be consulted for assistance.

The costs of ensuring that some ICs remain effective for the required period may be affected by the time period required. For example, ICs based on contractual agreements, such as restrictive covenants, may vary in the amount of legal effort required depending on the time the covenant must be effective. If only short-term effectiveness is required, and conveyance is not an issue, less extensive legal work may be adequate. However, as the effectiveness time increases, additional effort may be required to ensure future owners would be bound by the agreement.

3.4.2 Example - Probable Cost to Implement and Operate

In the example used, for prevention of use of well water all strategies rely on either purchase of the 10 homes using well water or providing an alternate water source and using health department restrictions to ensure use of existing wells does not continue. Because public water is already available in the community, connecting the 10 homes to this supply would likely be the least expensive option.

For reducing soil gas intrusion into existing buildings, several types of technical controls are considered. Institutional controls range from none, to purchasing single-family homes only, to purchasing all existing homes. Because drain tiles are already in place for the condominiums,

The indoor only testing, although definitely indicating indoor impacts, did not provide adequate information to determine if soil gas concentrations had substantially increased in certain areas of the complex or if some of the passive systems were not functioning properly.

5.1.2 Diagnostic Testing for Effectiveness

Diagnostic testing using building depressurization may be used to simulate building stack effects. The building may be depressurized either using mechanical means (e.g., blower doors; see Section 2) or by increasing the indoor temperature to well above the outdoor temperature. Mechanical depressurization does not, in general, provide a realistic test of passive ventilation systems which rely on indoor/outdoor temperature differences to create the vacuum needed for ventilation.

By monitoring the indoor air while artificially lowering the building pressure, an indication of control effectiveness during cold weather operation may be obtained during warm weather. However, the method is likely to give inaccurate indications of control effectiveness if soil gas pollutant concentrations are substantially below those upon which the strategy was based. Soil gas concentrations may be low due to a number of possible factors including lower water table and increased permeability of non-frozen ground surfaces.

5.1.2 Example - Diagnostic Testing For Effectiveness

Several engineering studies of the site were conducted over the spring and summer months. These studies included detailed mapping of soil gas concentrations throughout the complex. Concurrent with the soil gas mapping, indoor temperatures were increased to simulate winter operations. One study indicated that a significant amount of the methane was migrating from refuse present within property boundaries and recommended removal of all or part of the on-site refuse and the possible installation of a perimeter gas-control system. Gas collection systems at the property boundaries were installed but the indoor testing showed that this was ineffective in controlling methane entry into basements.

REFERENCES FOR SECTION 3

- EPA88a Radon Reduction Techniques for Detached Houses: Technical Guidance. Second Edition, EPA/625/5-87/019, January 1988.
- EPA88b Guidance for Conducting Remedial Investigations and Feasibility Studies Under CERCLA. EPA/540/G-89/004, OSWER Directive 9355.3-01, October 1988.
- EPA89 Risk Assessment Guidance for Superfund: Volume 1 - Human Health Evaluation Manual (Part A). EPA/540/1-89/002, December 1989.
- EPA91 Risk Assessment Guidance for Superfund: Volume 1- Human Health Evaluation Manual (Part B, Development of Risk Based Preliminary Remediation Goals). Publication 9285.7-01B, October 1991.
- EPA92 Assessing Potential Indoor Air Impacts for Superfund Sites. EPA-451/R-92-002, October, 1992.

be tested. Even slight air flow across an opening will cause the smoke pattern to drift in the direction of the air movement.

The pressure field created by sub-slab depressurization systems can easily be tested with smoke tubes. Test holes may be created by drilling through the slab with a 3/8 inch bit remote to the suction point. The system's pressure field may be tested by gently releasing a steady stream of smoke from the tube near the test hole opening. A good sub-slab suction field will draw the smoke stream into the test hole. This test may also be performed using unsealed openings rather than test holes. Incomplete suction fields may then be addressed by modifying the system.

An example of a typical smoke tube aided inspection might proceed as follows. Measurements of the indoor air indicate an insufficient reduction in indoor contaminant levels. Diagnostic testing of the single suction point, sub-slab depressurization system indicates a portion of the sub-slab region is unaffected by the mitigation system. The diagnostician identifies a concrete footing obstructing the extension of the pressure field.

The system is modified by installing a second suction point through the slab on the other side of the footing. Diagnostic testing of the modified system indicates full extension of the sub-slab depressurization field. Screening measurements of the indoor air indicate a significant reduction in indoor contaminant levels. Follow-up measurements will be taken to ensure seasonal weather variations do not cause indoor contaminant concentrations to increase.

Pressure and flow measurements.-- Active soil ventilation systems and forced-air ventilation systems require the mechanical movement of air for proper operation. Pressure and air flow measurements taken at points along the system can indicate system imbalances, blockages, and/or excessive air leakage. Inadequate pressure and air flow could require an increase in fan capacity or a reduction in the systematic resistance caused by excessively long duct runs, numerous directional changes, etc. Flow velocities in pipes and ducts can be measured using pitot tubes or hot-wire anemometers.

SECTION 4 EVALUATING A PROPOSED MITIGATION STRATEGY

This Section discusses general procedures that could be used in conducting a screening review of indoor air mitigation strategies that have been proposed. This is not general guidance for the screening analysis; rather, it represents a process that may be a useful tool for conducting such an analysis. The review is useful as part of the alternatives screening process described in section 430(e)(7) of the NCP. The procedures in this section do not include, nor do they substitute for, the detailed evaluation of alternatives required for remedy selection. Note - the screening referred to here is only a preliminary screening to eliminate alternatives that are significantly less effective, infeasible, or grossly excessive in cost. The procedures in this section assume that the reviewer was not involved in the development of the indoor air mitigation part of the alternatives being considered. The procedures, however, may also be of benefit in reviewing mitigation strategies under development.

4.1 OBJECTIVE OF EVALUATION

The objective of this screening evaluation is to determine which alternatives are adequate to proceed to detailed evaluation. Comparisons made during screening are generally made between similar alternatives with only the most promising carried forward for further analysis. As indicated in Section 3, the NCP requires that defined alternatives be evaluated against the short- and long-term aspects of effectiveness, implementability, and costs. The objective of Section 4 is to assist the reviewer in addressing these objectives and to provide procedures to ensure specific concerns relevant to the indoor air impacts are considered.

4.2 REVIEW SITE RELATED INFORMATION

Any review of a proposed strategy should begin with a review of the information about the site. The purpose of this review is to determine if

made using the smoke stick testing procedures above. Combustion appliances should be checked to ensure back-drafting of exhaust flues does not occur due to the operation of the mitigation system. Excessive air flow through the building may cause occupant discomfort generating complaints of "drafts".

Mitigation systems relying on the dilution of indoor concentrations of contaminants with uncontaminated outdoor air can be evaluated by determining the ventilation effectiveness of the combined HVAC/mitigation system. Increased outdoor air exchange may exceed HVAC system capabilities and/or cause heating and cooling expenses to dramatically increase. Determining ventilation effectiveness in a building is complex and should only be performed by experienced and well qualified diagnosticians. Whole building air exchange rates may be estimated, but in order to test the entire building, tracer gases must be used. When interpreting the tracer gas data, the diagnostician must consider the dynamics related to weather conditions, mitigation system operation, and HVAC system operation.

5.1.3 Example - Diagnostic Testing with Corrective Action

After perimeter soil gas extraction proved unsuccessful, alternative strategies were investigated. Numerous families had already been evacuated. Control to at least 100 ppm methane in a confined space was set as the objective (This study, which was not conducted in the United States, contained the following rationale for this objective: "...a proposed standard of 100 ppm has been suggested in the United States for a methane concentration in a confined space."). Because a passive venting system had been installed (required by the institutional control) using a drain tile system around each townhouse cluster, the next logical step was to convert the system to an active drain tile ventilation system which was accomplished by attaching suction fans to the existing passive venting systems.

However, after the fans were installed negligible sub-slab soil depressurization resulted and the required reduction of methane gas entry was not achieved. Diagnostic testing of the mitigation system components was conducted. Smoke testing of entry routes was conducted and sub-slab

4.2.3 Comparison of Site Information to the Strategy

The proposed strategy should be reviewed to determine whether or not the information developed during the review of background information per Section 4.2.1 has been considered. Note that, at this point, the review is only to determine if all potential pollutants and pathways have been addressed for the appropriate time frames. The likely effectiveness of those measures proposed by the strategy will be reviewed in Section 4.4.

Using the information developed above, prepare a table giving, in the first column, a list of all impact pathways, the expected duration of impacts by this pathway, and the pollutants potentially impacting through those pathways (i.e., those included in the proposed strategy and those added by the reviewer). Pathways and pollutants added by the reviewer (i.e., those potentially missed during strategy development) should be distinguishable, perhaps by using different color writing, from those in the proposed strategy. Review the various technical and institutional controls utilized in the strategy and list them individually across the top as headings for each additional column. Table 4.1 shows the general appearance such a table would have. Individual technical and institutional controls would be entered as headings for the columns under "Proposed Technical and Institutional Controls".

Beginning in column 2, place a check by each pathway to which that control method is applicable and the pollutant(s) it is expected to control to some degree (should be stated in the proposed strategy). The reviewer should also place a different mark in this column, such as an asterisk, by each pollutant in column 1 the reviewer has reason to believe would also be controlled by this method. Complete the table for all proposed control methods. Place a flag, such as a red "x", in column 1 by any pathway, or pollutant listed for a pathway, not addressed by at least one control method. Use a different kind of flag to indicate pathways included in the proposed strategy for which there is no supporting evidence in the site investigation reports.

ters which showed consistently elevated methane levels, additional suction points were installed with favorable results.

System failures were simulated to determine the effect of possible system down time on indoor methane concentrations. The system failure simulations indicated that elevated indoor methane levels might occur under some conditions (such as immediately following heavy rainfalls or during periods when the ground was snow-covered or frozen) and that secondary technical measures should be considered. Because indoor concentration rose rapidly when the fans were not operating, an auxiliary power source was considered to ensure limited system down time during power failures. However, the local utility company was contacted and indicated that the maximum power failure duration reported for the community over the last 2-1/2 years was 84 minutes. Therefore, costly back-up power or other technical measures were not considered warranted. Meticulous entry route sealing was considered adequate to reduce the short-term entry rate of methane-laden soil gases.

5.2 INSTITUTIONAL CONTROLS

Institutional controls implemented as part of the strategy should be reviewed to ensure they are achieving the desired objective(s), are being followed, and remain in effect. This will generally involve efforts of both on-site evaluators and legal professionals.

The mechanics of the ICs should be reviewed to determine if they are working. Examples include determining if property-based restrictions, such as easement and covenants, are included in deeds resulting from property transfers and determining if restrictions based on police powers, such as well use restrictions, zoning classifications, building permit requirements, etc., have been changed.

It should be determined if the property is being used inconsistently with the ICs. The inspector should compile a list of activities prohibited by the ICs prior to on-site inspection. Examples which the inspector should look for include inappropriate well usage and excavations. If the

release has been occurring for at least 20 years. It is likely, therefore, that other pollutants, either from material stored in the tank over 20 years or degradation of the TCE in the groundwater, should have been found. Analytical data from the monitoring conducted should be obtained and reviewed. In Table 4.2, additional pollutants are listed as Pollutant B. The duration expected was determined from remediation plans for the site. These plans indicated site remediation would take no more than 10 years.

The proposed strategy indicated monitoring was done in fall and winter and that only low concentrations of TCE were detected in the ambient air. The ambient air pathway was not considered further. As no information was provided regarding potential changes in the depth of the water table, due to snow melt or spring rains, and the effect that might have on surface emissions, this pathway for pollutants released into the air near the buildings and possibly drawn into the indoor environment may have been incorrectly discounted. Additional information on variations in water table depth are needed. Monitoring or modeling may be needed to estimate the importance of this pathway. This additional potential pathway was added to the table.

Soil gas intrusion and indoor uses of the contaminated groundwater were pathways given in the strategy. Because other pollutants besides TCE are expected, a "Pollutant B" was added to each pathway.

The proposed technical and institutional controls given in Table 3.4 are listed across the top of the table. For ambient air impacts (soil gas rising to surface near the building), it is likely that the "Pump and Treat" and "Consent Agreement" controls would reduce the indoor air impacts. Therefore, a check is placed by TCE, listed in the strategy, and an asterisk by Pollutant B, added by the reviewer. None of the other controls are expected to reduce the ambient air impact.

For the soil gas intrusion pathway, check marks are placed by 5 of the controls. The first two are technical controls that work to prevent soil gas entry into existing buildings. The "Building Restriction" control

tile ventilation system be installed. The information provided for the example indicates the IC was complied with exactly as written. That information also shows that the IC was inadequate.

Because the drain tile systems were plugged, it is impossible to determine whether or not the IC could have worked. However, it is likely that either specifications for the installation were inadequate or that installation inspection requirements were inadequate or not followed. Also, because the sub-slab depressurization system performed well, it is quite possible that the fan assisted drain tile ventilation system would also have worked. Thus, the failure of the IC to ensure an adequate drain tile system also prevented the use of an efficient and inexpensive technology.

In this case example, it would have been appropriate to examine the IC for the above concerns as soon as it was discovered that the drain tiles were plugged. It may have been possible at that stage to modify the IC for construction of additional townhouse clusters. As this case was concluded, the ICs for future development require removal of buried refuse and installation of sub-slab ventilation systems operated in vacuum mode.

Table 4.2 Example Review of Site Information

Impact Pathways	Proposed Technical and Institutional Controls						
	Alternate Water Source	Drain Tile Ventilation	Modify Ventilation	Pump and Treat	Well Use Restriction	Building Restriction	Consent Agreement
Ambient Air Duration - 10 yrs Pollutant - TCE Pollutant B				✓ *			✓ *
Soil Gas Duration - 10 yrs Pollutant - TCE Pollutant B		✓ *	✓ *	✓ *		✓ *	✓ *
Indoor Use of Groundwater Duration - 10 yrs Pollutant - TCE Pollutant B	✓ *			✓ *	✓ *	✓ *	✓ *

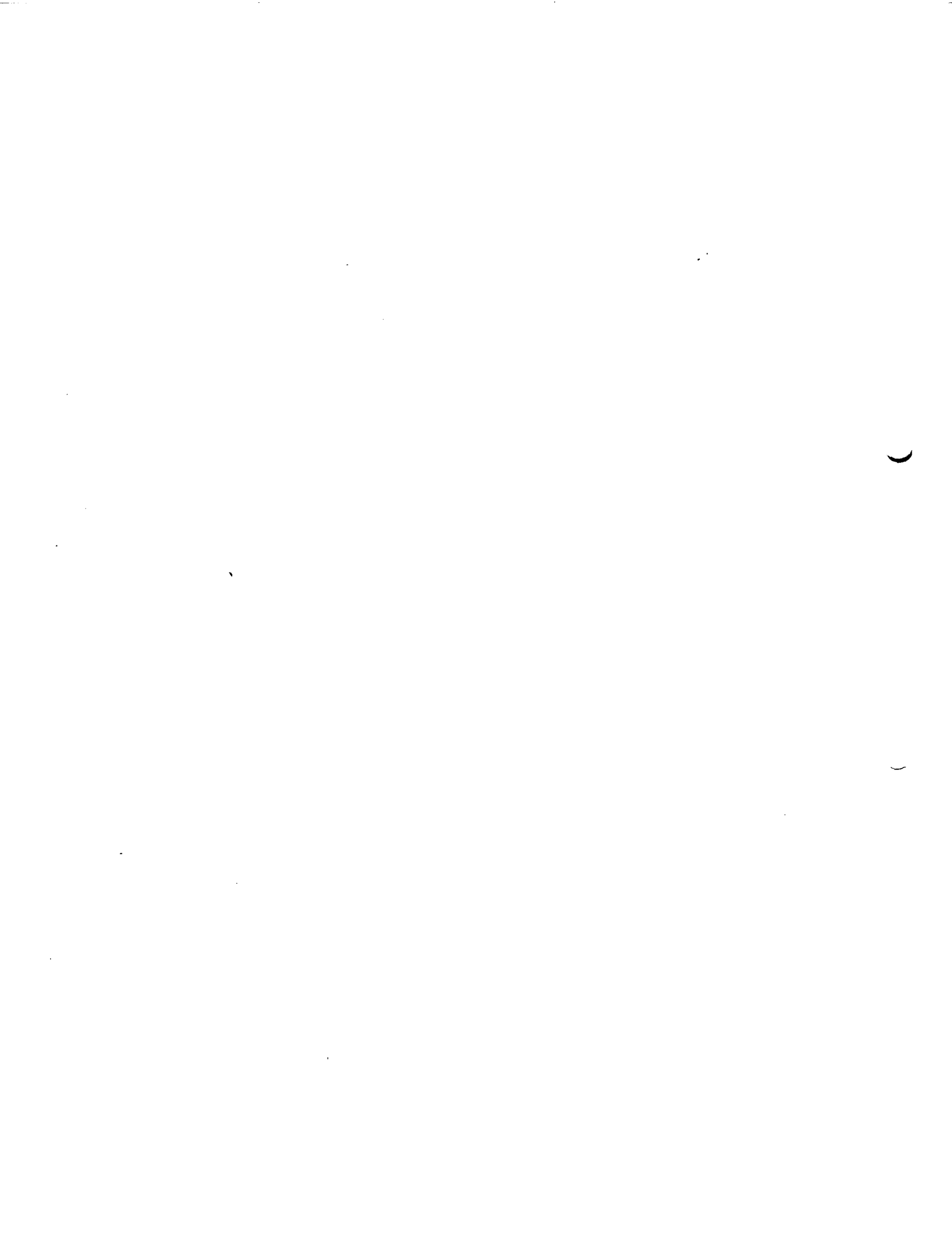

4.3.2 Current and Intended Future Uses

The proposed strategy should state the current uses of the impacted area. Current usage information should include whether the area is used for heavy or light industrial, commercial office buildings, high density residential, single-family detached housing, and schools. It should indicate whether the area is urban or rural, or other information to indicate population density. If mitigation is proposed for only a small number of structures, the strategy should indicate the current usage of those structures.

If adverse impacts for the area are projected to continue for several years, the proposed strategy should include a discussion of intended future uses.

4.3.3 Measured and Estimated Level of Impact

The proposed strategy and supporting impact assessment information should be compared to determine if measured and estimated impact levels are consistent. In this section of the table being created, list the pollutants contained in the table created in Section 4.2 above (Table 4.1). Beside each, insert information given in the proposed strategy for the measured or estimated indoor air concentration of that pollutant which is attributed to impacts from the site. If no concentration data are given for a pollutant, insert an "N" in this space. Compare these to the concentrations given in the indoor air impact assessment document. Place a check by those that are in substantial agreement, a question mark by those in significant disagreement, and an "x" by any of the pollutants not listed in the assessment document.

4.3.4 Structural Characteristics

The strategy should be reviewed to determine if the characteristics of structures for which mitigation is proposed have been adequately addressed. For cases in which future development must also be considered, the assumed characteristics of those structures should be reviewed.

The plume passes beneath several residences, down a steep hill, and beneath the library of an elementary school. TCE concentrations in groundwater near the school of over 7,500 ppb have been measured. Soil gas monitoring wells were installed around the school. The maximum concentrations of soil gas VOCs detected, 99 ppm v/v 1,2 DCE and TCE, were found, at 3 foot depth, 10 feet from the school library on the side facing the plume source. Indoor air monitoring was conducted in the school. Elevated levels of VOCs were found in several areas. The maximum concentration found was for TCE, 100 ppb v/v, in the library.

A.1.1 Structural Characteristics

The 6 residences which were mitigated are all duplexes constructed over slabs on grade. The school is a two-story building constructed slab on grade. However, because the building was built on a grade, the library connects with the second floor of the building. There is at least one above grade crawl-space adjacent to the library. Heating and ventilation in the library is accomplished using self-contained forced-air exterior wall units to which steam is piped from the boiler room. The steam pipes penetrate the floor slab. Additional cracks along the slab/floor interface are present. Although as built construction drawings were not obtained, it was suspected that a French drain tile system was installed to facilitate water drainage beneath the library structure because a possible drainage pipe was found in a catch basin manhole.

A.1.2 Systems Installed

Initial efforts at the school included increased ventilation of the library and installing a fan to ventilate the crawl space. These proved to be inadequate. A sub-slab depressurization system, based on radon mitigation guidance similar to that described for Case Example 3 below, was installed. This system includes alarms to indicate malfunction of the system. The exhaust from the sub-slab depressurization system is treated by activated carbon to reduce VOC emissions and possible reintroduction to the building through the air intake system.

Sub-slab depressurization systems were also installed at each of the 6

- Wall covering; unfinished, partially finished, fully finished as living area.

Assumptions made for new construction in currently developed areas or in undeveloped areas should be reviewed to determine if they are in general agreement with normal construction practices for the area. Assumptions made based on significantly more expensive construction techniques should be flagged for comparison with any proposed institutional control that might require such construction.

4.3.5 Proposed Technical and Institutional Controls

Complete the table under development by listing the various technical and institutional controls utilized in the strategy individually across the top as headings for each additional column. Beginning in column 2, place a check by each item of column 1 which is addressed for that control method in the proposed strategy. The reviewer should also place a different mark in this column, such as an asterisk, by each item of column 1 the reviewer has reason to believe would also be addressed by this method. Complete the table for all proposed control methods. Place a flag, such as a red "x", in column 1 by any item not addressed by at least one control method. This would also include pathways or pollutants added by the reviewer and potentially overlooked during strategy development. Use a different kind of flag to indicate which, if any, of the items in column 1 lack adequate documentation to justify their inclusion in the strategy.

4.3.6 Completion of Review

The consistency and completeness check for inclusion of information for the impacted area is now complete. It indicates whether or not all appropriate items have been considered. It does not indicate that the controls are adequate for the mitigation. If there are significant data gaps, the reviewer should obtain missing information deemed necessary to complete the review.

diameter perforated plastic big "0" pipe laid around the exterior of the perimeter building foundation. A 100 mm diameter non-perforated riser was attached to the big "0" pipe at the end of each townhouse cluster and extended vertically to the top of the building. Passive venting systems rely on two natural phenomena to develop the suction needed to draw soil gas away from sub-slab entry routes: 1) air movement generated by wind currents across the roofline that develop a low-pressure region near the roof; and 2) the natural thermal effects resulting from buoyant forces inside the vertical riser.

Three perimeter methane collection systems were also installed on the landfill/townhouse development property border. The collection systems were intended to control the migration of methane laden soil gas from the adjacent landfill. Indoor air sample results indicated that the perimeter collection systems were ineffective. The occupants of a majority of the townhouse units were evacuated.

Several studies were conducted to evaluate the methane migration and intrusion problems experienced on the site. One investigator hypothesized that a significant portion of the methane was being generated from the decomposition of refuse buried within the townhouse community boundaries. His recommendation was to remove the buried refuse and install a perimeter gas-control system. No mention of the application of soil ventilation technology was made in his recommendations. The property owners questioned the feasibility of the recommendations and decided to explore alternative possibilities.

Another investigation of the site was conducted by a firm familiar with radon mitigation using soil gas ventilation and suggested that active soil ventilation may be a cost-effective and suitable control strategy. An objective of the strategy involved using a phased approach under experimental conditions to derive a technical control measure applicable to the entire townhouse community.

A.2.2 Methane Levels

While the engineering studies of the site were being conducted, indoor

For "Drain Tile Ventilation", additional checks are placed by several structural items because these items were specifically considered in selecting this control for the Strategy 1 alternative. Checks are placed by all items for "Building Restrictions" except for current concentrations of indoor air pollutants. Note that checks are also placed by current uses because the building restrictions would apply to any modifications to existing structures. This is the only control that addresses soil gas intrusion from the septic systems through the floor drains and then only for new/modified construction. The strategy did not specifically address mitigation of current structures for this potential soil gas intrusion through the floor drain, the trap of which likely is not consistently water filled. This can be a major entry route and must be addressed.

4.4 REVIEW PROPOSED MITIGATION STRATEGY TECHNIQUES

Assuming the necessary information has been obtained, the reviewer should proceed with assessing whether or not the proposed strategy is likely to satisfy the mitigation requirements. Elements of this review which are discussed below are:

- comparing the strategy to those successfully used in previous cases,
- modifications of prior successful strategies needed to satisfy the specific case,
- reasonableness of control effectiveness estimates,
- reasonableness of cost estimates,
- enforceability of institutional controls proposed.

4.4.1 Comparability to Strategies Used in Similar Cases

Confidence in a proposed strategy is increased if it uses similar mitigation methods to those that have been successful in comparable cases. There are only a limited number of implemented indoor air impact mitigation strategies at CERCLA sites at which EPA was the lead Agency. Although

optimize system performance and to resolve outstanding issues. A methane concentration of 100 ppm was selected as an appropriate mitigation level.

A.2.3 System Installed

The proposed initial technical control involved attaching an in-line fan to the existing passive venting system to apply a suction field of -25 pascals in the vent pipe at the furthest point from the fan. Upon connectivity testing, the perimeter big "0" piping system was found to be severely blocked with silt and debris. These blockages drastically reduced the performance of the system. Where possible the blockages were removed or the big "0" piping was replaced. Three in-line Kanalflakt fans were installed on the vertical risers and the active sub-slab depressurization (SSD) system was activated. In several instances where the existing venting system was of negligible use, series of interior suction points were installed and tied into the unperforated big "0" pipe mounted on the exterior of the building. The interior suction points were installed by penetrating through the interior basement floor slab into the underlying layer of aggregate. Pressure and flow measurements taken at points in the sub-slab region and in the vent stacks were collected to determine optimum system performance.

System failures were simulated during the Alternatives Assessment Phase to determine the effect of possible system down time on indoor methane concentrations. The system failure simulations indicated that indoor methane levels rose substantially in some townhouses over several hours. Local utility company records indicated that the maximum power failure duration reported for the community over the last 2-1/2 years was 84 minutes. Therefore, back-up power was not considered likely to be warranted.

A.2.4 Volatile Organic Compound

Many volatile organic compounds were detected in the soil gas, basements, and in the system exhaust pipes. These included several freons, halogenated organics, benzene, toluene, and aliphatic hydrocarbons. Vinyl chloride, about $2 \mu\text{g}/\text{m}^3$, was detected in the system exhaust gases at one cluster. The investigators did not consider the VOCs to be of concern and no information was presented on the percent reduction achieved by the installed systems

confidence will not be as high for proposed strategies not using those control methods, they should not necessarily be discarded. Performance information for the control methods, as discussed in Sections 4.4.2 and 4.4.3 below, may be useful for assessing their applicability in specific cases. Performance information is also indicated in the case examples in the Appendix.

Information about the performance of indoor air impact mitigation strategies may also be available for sites at which a State Agency had the lead. Performance information may also be available for Radon program activities and RCRA program cleanups.

4.4.2 Applicable to Specific Case

Using the information developed in Sections 4.2 and 4.3, information contained in the proposed strategy document, and other technical information such as that in Section 2, the reviewer can assess the applicability of each control proposed to the particulars of the specific case. Information in the proposal on the applicability of the method and its limitations should be reviewed and compared to the site specific information developed in Tables 4.2 and 4.4. For each control method on these tables, review the information provided to determine if the method is applicable to the items checked. Look particularly for items that may be major impediments. For example, drain tiles blocked with water during wet weather are a major impediment to drain tile ventilation. If major defects are found, the strategy should be eliminated from those that will be subjected to detailed evaluation for selection of the remedy.

If no major defects are found, the reviewer should consider the methods being proposed to mitigate a specific type of impact, such as use of contaminated groundwater, as a group. Attention should be given to any group of methods that rely on several substantially similar techniques to effect incremental control as this may be an unreliable approach. Attention should also be given to groups that contain a large number of different techniques for the control of a type of impact. This may indicate that the strategy proposed is more conservative than necessary.

tions reported. Therefore, carbon monoxide was not considered a concern.

A.3 CASE EXAMPLE 3 - RADON MITIGATION FOR BASEMENT AND CRAWLSPACE

The contaminant source was improperly disposed radium and related radionuclides. The material was disposed at various location and has impacted several different buildings, both commercial and residential. Similar mitigation techniques were used in all locations, although details of the installations are highly site specific. This example considers the mitigation at only one of the affected properties.

Some of the general specifications for all work were:

- Source control. Remove as much of the contaminated soil and debris as practical.
- Cut and patch structural elements so as to not reduce load-carrying capacity or load-deflection ratio.
- Cut and patch construction exposed on the exterior or in occupied spaces so as to not reduce the building's aesthetic quality or result in visual evidence of the cut and patch.
- Use materials identical to, or which match, existing materials. Remove existing floor or wall coverings and replace with new materials, if necessary to achieve uniform color and appearance.
- Avoid interference with use of, or free passage to, adjoining areas so as to allow for owner occupancy and use by the public.
- Install products, materials, and system components to provide adequate space for inspection, adjustment, future connections, or replacement, where appropriate, avoiding interference with other building components requiring similar access.
- Maintain a set of "as built" drawings.
- Upon completion, clean each surface or unit to the condition expected in a normal building cleaning and maintenance program.

A.3.1 Building Characteristics

The impacted structure is two-story single-family residence with a par-

Cost estimates should be reviewed to determine if site specific conditions have been taken into account. These might include such items as additional expenses for ICs due to complex state laws and contractor expenses in support of property acquisition. They may also include temporary relocation expenses of affected parties, and remodeling expenses due to installation of technical controls.

4.4.5 Enforceability

Enforceability applies to the institutional controls used. The proposed strategy should contain regional counsel concurrence with the controls proposed. If the proposed strategy does not contain this concurrence, possibly indicating counsel review was not obtained, counsel should be contacted for an opinion. Particular attention should be given to unusual ICs, those that rely on police powers of local governments, those that rely on PRP property interests, and any IC that must be effective beyond the end of the remedial action. The remedy available in the event of a breach should also be considered. If remedy is limited to damages and does not allow enforcement of the IC, effectiveness of the IC is substantially reduced.

4.4 EXAMPLE - REVIEW MITIGATION STRATEGY TECHNIQUES

Comparability to Strategies Used in Similar Cases -- The technical controls "Alternate Water Source" and "Pump and Treat" proposed are proven technology and have been shown to be effective for the general type applications proposed. "Drain Tile Ventilation" and "Modify Ventilation" have been used, primarily for radon mitigation, with mixed success (see Section 2). There is little experience with these techniques at CERCLA sites. All of the institutional controls, except the consent agreement with the PRP, rely on police powers of the local government. There is a mixed history using this type of control. Thus, although there is some experience with the controls, the experience is not extensive and thus there is some cause for concern with the methods used in this strategy alternative.

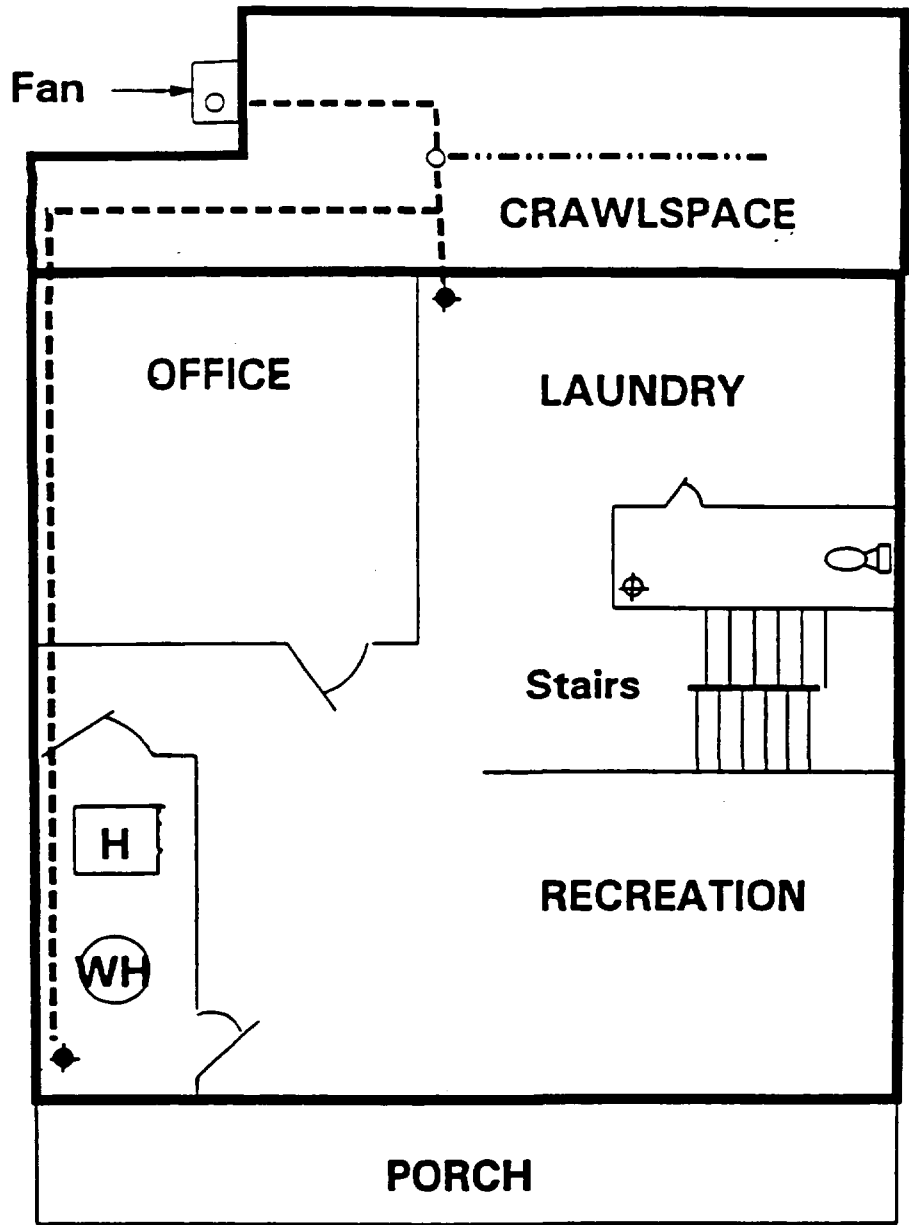

- | | |
|----------------------------------|------------------------|
| ———— Foundation Wall | ○ Vertical Pipe |
| ----- Solid Pipe | ⊕ Sewage Pipe |
| - · - · - Perforated Pipe | ◆ Floor Suction |

Figure A-1 Soil Ventilation System

REFERENCES FOR SECTION 4

- EPA88a "Guidance for Conducting Remedial Investigations and Feasibility Studies Under CERCLA", EPA/540/G-89/004, OSWER Directive 9355.3-01, October 1988.
- EPA88b Radon reduction Techniques for Detached Houses: Technical Guidance (Second Edition). EPA/625/5-87/019. January 1988.

Ten feet of perforated 3-inch diameter pipe was placed in the crawl space and connected to a solid wall riser pipe. An inline damper was placed in the riser pipe and the riser was connected to the manifold. The perforated pipe and entire crawlspace floor was covered with an EPDM membrane. The membrane was sealed to the foundation walls with an expandable urethane spray foam.

A 5-inch diameter hole was drilled through the crawlspace wall and the manifold pipe routed through the hole. The manifold was connected to an inline fan using a vibration and sound absorbing rubber coupling. The installation was sealed using urethane caulk. The fan exhaust was routed vertically from fan housing to above roofline using ultra-violet light tolerant PVC pipe.

A flow verification switch was installed on the negative pressure side of the fan and an "on when running" indicator light and audible alarm with override switch installed. The fan was wired to run continuously and connected to a different circuit from those used for the indicator light and alarm. All system electrical connections were made to a separate panel, located in the heater room, which was identified as the Sub-slab Depressurization Control Panel.

The system was activated and all leaks sealed. The pressure field under the slab was measured, making use of several small holes drilled in the floor, and the adjustable dampers positioned to achieve the desired vacuum at all locations. The dampers were sealed in place and the diagnostic holes patched.

A.3.4 System Effectiveness

Discussions with the RPM for the site indicated the system reduced indoor air radon levels to design specifications given in Section A.3.2.

A.4 CASE EXAMPLE 4 - AMBIENT AIR PCB DUST, SOURCE CONTROL

Indoor air impact at several residences occurred from wind borne dusts from a nearby unpaved road. Dust control measures for the roadway had included oil application. The oil used contained PCBs. Dusts in the buildings were collected by taking wipe samples. No indoor air monitoring was done. The

SECTION 5 EVALUATING EFFECTIVENESS OF IMPLEMENTED MITIGATION STRATEGY

This section includes evaluation exercises and procedures useful for reviewing the basic elements of implemented indoor air impact mitigation strategies. Section 5 provides assistance in conducting a quantitative evaluation to determine the technical effectiveness of an applied mitigation technique. In some instances information is provided on corrective actions which may be taken when technical systems are found ineffective. Section 5 provides assistance for the evaluation of ICs which govern the strategy's operation.

Evaluation of the effectiveness of technical controls soon after their installation is normally done as part of any CERCLA cleanup. The site manager may also require reviews of all control techniques as deemed appropriate. Review of indoor air mitigation measures at a site may also be part of the 5-year reviews required by CERCLA. These reviews are required at least every five years after initiation of cleanup at sites where hazardous substances, pollutants, or contaminants remain on-site at a level that does not allow for unlimited use and unrestricted exposure. Section 5 provides assistance with the conduct of 5-year reviews that may be required. This assistance is supplemental to CERCLA and does not supersede any CERCLA requirements.

5.0 EXAMPLE - BACKGROUND

Application of evaluation procedures discussed in this Section will be applied to a soil gas migration problem experienced at a group of townhouse clusters built on land next to an active landfill. Methane was detected entering into basements and slab on-grade structures of buildings proximate to the landfill. The source of the methane was the decomposition of buried refuse.

- Tier II 20 to 200 pCi/l
Actions should be taken within months to reduce levels to as far below 20 pCi/l as possible.
- Tier III 4 to 20 pCi/l
Actions should be taken within a few years to reduce levels to 4 pCi/l or lower.
- Tier IV 4 pCi/l or Below
No action indicated. Exposures are considered average to slightly above average.

For buildings falling in Tier III, confirmatory measurements were made. Alpha-track monitors were placed in the buildings for one month to confirm levels. If the screening level was above 10 pCi/l, confirmatory testing also included 7-day working level monitors. If the levels were confirmed, a gamma radiation survey was also conducted. Only buildings with elevated gamma levels were considered radium-contaminated properties.

Only 62 of the 67 buildings designated for radon screening were tested because either the owner could not be contacted, the canisters were not returned, or the owner refused. One building was designated Tier I, 3 buildings Tier II, 8 buildings Tier III, and 50 buildings Tier IV. Gamma surveys were required at 6 buildings but one owner refused. Mitigation plans were prepared for the four buildings in Tiers I and II. The estimated costs to mitigate these 4 buildings was \$98,000. Mitigation systems were installed at only three of the locations. The fourth home owner rejected the mitigation plan and, in 1990, an action memorandum was signed to move that home to an uncontaminated property owned by the homeowner.

A.5.1 Mitigation of Buildings 1 and 2

Mitigation at two of the affected structures used sealing and sub-slab depressurization much as described in Case 1 above. A brief description of the building and specific differences in mitigation procedures are given below.

If direct testing is conducted under conditions expected to result in worst, or near worst, case conditions for impacts, or if impact is from a pollutant not normally found in indoor environments this type testing may be adequate.

Air sampling may need to be conducted periodically to account for seasonal variations. Direct testing for soil gas impacts during warm weather will likely be inappropriate in some regions of the country because building stack effects and permeability of surface soils may not be adequately addressed. Building stack effects tend to be greater during cold weather because the temperature difference between the indoor and outdoor environments is larger. In addition, ground surface permeability is reduced when it is rain soaked, frozen, or snow covered, resulting in a lower transport of soil gas contaminants through the ground surface. Under these conditions, pollutant concentrations in the soil gas may increase and an increased volume of soil gas will tend to move towards and through openings in the building shell in contact with the ground. Testing for control of impacts from groundwater intrusion during protracted dry periods is likely to overestimate control effectiveness.

5.1.1 Example - Direct Indoor Air Measurements

After three townhouse clusters were constructed, indoor air sampling measurements were made using spot and continuous monitoring. The measurement results showed one housing cluster reached explosive methane concentrations; another cluster had moderate methane concentrations; and a third cluster was unaffected.

Testing was conducted in late winter and early spring when the ground surface in the area was saturated from winter snow melts. It was felt that soil gas intrusion would be at a maximum at these times because the ground surface would have a low permeability under these conditions, and because there would be a large stack effect in the buildings due to the substantial indoor/outdoor temperature differences. A large stack effect was expected to result in good performance of the passive ventilation system.

ture.

A.5.2 Mitigation of Building 3

This residential structure was built in the 1950's. The property had been a strip mine, a swamp, and then filled in and divided into lots. The structure is built over both crawlspace and a partial basement. The crawlspace, which covers 60 percent of the area, is composed of several subcompartments with poor accessibility. The basement is not livable space. There is a high water table and a sump is located in the basement to collect and remove water from under the slab.

Initial mitigation efforts focused on sub-slab depressurization in the basement and pressurizing the crawlspace. The depressurization system was installed by placing a cover over the sump, inserting the suction pipe through the cover, running the manifold into the attic where the fan was installed, and exhausting through the roof. All floor and wall penetrations were sealed. Heat ducts were removed, replaced, and the new duct joints sealed. Preparations for crawlspace pressurization included sealing all exterior openings, all connections to the basement, and installing plywood on the joists above the crawlspaces. A hole was cut in a closet floor above the crawlspace and a pressure verification switch with alarm placed in the crawlspace. A duct was inserted through the hole and sealed in place. The duct was connected to a fan installed in the closet wall. Performance requirement was that the system maintain a minimum pressure difference between the living area and the crawlspace of 4 pascals.

Testing over the next two years indicated that radon concentrations were slightly above the objective of 4 pCi/l but that in the last 6 months the system performance was deteriorating. In addition, the crawlspace fan had failed at least twice and, on the last occasion, a new type fan was installed. A decision was made to modify the system.

The sub-slab depressurization system was checked by drilling a small hole in the floor 6 ft from the sump with the intent of measuring the pressure. The soil on the drill bit was wet clay. In addition, the hole quickly

5.1.3 Diagnostic System Testing with Corrective Actions

If it is determined that the level of mitigation is insufficient, diagnostic testing of the system may be conducted. Diagnostic testing can aid in the identification of design or installation errors or omissions and/or system modifications that may improve the efficiency of the system's operation. Basically, there are three reasons for performing post-mitigation diagnostics on a system: 1) to ensure that the system is operating as intended; 2) to identify system modifications that might increase the level of mitigation; and (3) to provide some indication of cold weather operation during warm weather testing as discussed in Section 5.1.2 above.

No definitive set of diagnostic procedures exists for the testing of mitigation systems. Post-mitigative radon diagnostics have been performed by researchers and mitigators. A portion of the testing may be done with the building artificially depressurized. This technique is useful during mild weather to simulate the behavior of the building during cold weather. A "blower door" is useful to achieve the desired negative pressure (about 0.05 inches water column). The blower door is simply a large fan that may be attached to an exterior door and exhausted outdoors until the desired indoor to outdoor pressure differential is achieved. Some of the tests that have been used by diagnosticians are:

Visual inspection and smoke stick testing.-- Inspection of system components should be performed, including the integrity of sealed entry routes, system duct connections and hangers, fan wiring, etc. Each component should be inspected for proper installation and operation. The diagnostician should pay particular attention to the effects of HVAC system operation relative to the mitigation system operation.

A smoke tube with an attached aspirator bulb or a smoke punk is a useful tool when conducting visual inspections. The smoke permits the evaluator to see otherwise invisible and/or imperceptible air movement. Air movement across unsealed entry routes or across separate floors of the building may be easily tested by releasing smoke in or near the opening to

routinely buried in the solid waste area. There is an active gravel quarry to the west with several residences between it and the solid waste area of the landfill. The site is partly owned by the town and a private citizen. The Town operates an active waste transfer station on the site. The private citizen has a dog kennel, firing range, and bird hunting preserve on the site.

The site was added to the NPL list in 1989 primarily as a result of contaminated groundwater impacting the local residential water supply. In 1985, the Town authorized construction of a municipal water line extension to the transfer station and eight residential dwellings in the immediate site area. After negotiations with the PRP to conduct an RI/FS were unsuccessful, a federally financed RI/FS was initiated. The soil gas study conducted as part of the RI/FS detected methane and non-methane VOCs (vinyl chloride as the principal component) migrating off-site and toward the residences. Both gases are of concern and are being dealt with under removal action authority.

A.6.2 Access Agreements

In March 1991, EPA sent access agreements to the residents and citizen owning part of the site. The agreement requested permission for access for the purposes of taking samples to scope the extent of contamination. The citizen/owner refused this request. EPA met with the citizen/owner to discuss his concerns and in May sent a second letter indicating EPA's willingness to comply with certain request made by him. This letter also requested that hunting, target shooting, etc., be curtailed during the hours the response activities were occurring. The Citizen/owner refused this request but did sign the original access agreement request. EPA began limited response activities under that agreement. Discussions were held in June and July over this refusal. On both occasions, the citizen/owner clearly stated that hunting activities would not be curtailed.

In March of 1992, EPA issued an Administrative Order to achieve compliance with the previous requests. The order was issued under the authority vested in the President of the United States in Section 104(e) of CERCLA, 42 U.S.C § 9604(e), the NCP, 40 CFR § 300.400 (d) and cited the delegation of that authority to EPA by Executive Order 12580, 52 Federal Register 2923, and

Sub-slab and wall void pressure field measurements.-- Active soil ventilation systems can be tested for proper operation by measuring the suction at various points under the slab. An evaluation of how well the suction field is extending to various sections of the slab may be made. Measured pressure differentials will likely be very small. A micromanometer sufficiently sensitive to detect differentials of 0.01 inches water column is a useful tool when conducting pressure field measurements.

On/off cycling of the mitigation system and recording of pressure differentials may be useful in verifying proper system operation. Pressure field extension measurements can be made through 3/8-in. test holes drilled through the slab at various points remote to the ventilation point. Such measurements can be particularly useful if the initial level of mitigation is unsatisfactory. Modification of the system, to include additional ventilation points, may be indicated in areas in which the pressure field of the system is insufficient.

Measurements to ensure proper venting of combustion appliances should be performed. Active mitigation systems may draw indoor air from the building through former entry routes and in effect depressurize portions of the building. This depressurization may effect the draw of exhaust flues. Air flow measurements and smoke pencil testing should demonstrate that air movement in exhaust flues is consistently upward during mitigation system operation.

Spot contaminant measurements.-- If the level of mitigation is unsatisfactory, direct-reading instruments (such as an OVA), adequately sensitive for the particular pollutant(s) of concern, may be used to identify "hot spots" in the building. Identification of these hot spots may indicate unaddressed entry routes or additional sources. System modifications can be designed based on these spot contaminant measurements.

Ventilation measurements.-- The effects of the mitigation system on the ventilation rate should be evaluated. A qualitative estimation of the effects of the system on the building's indoor air flow patterns can be

- Notify PRPs and give them the opportunity to implement the removal action.
- Coordinate with the RPM to ensure the removal action will be consistent with the remedial action.
- Institute an interagency agreement with the Corp of Engineers for a rapid response contract to develop engineering and design plans to mitigate the underground migration of methane, vinyl chloride, and other VOCs.
- Activate the EPA Emergency Response Cleanup Services removal contractor to implement the design and engineering plan upon its completion.
- Negotiate an operation and maintenance agreement with the State local community, or PRP for the anticipated active gas collection system. Must be in place before construction begins.
- Measure and address emissions of hazardous gases from any collection system installed.
- Provide monitoring adequate to provide an early warning system and to determine the effectiveness of the actions.

A.6.5 Invitation to PRP

Based on available data, including that collected in October 1992, it was recommended that methane monitors be placed in two homes and that a sub-slab depressurization system plus a methane monitor be install in another home while the overall design is being completed. This information was transmitted to the PRP in the notice referred to in Section A.6.4 above and in a meeting among the PRP, EPA, and the State. The PRP agreed to immediately implement the above two recommendations. They also requested an opportunity to evaluate the feasibility of assuming the costs associated with the overall mitigation design and the implementations of the recommendations.

pressures were measured in test holes drilled into the townhouse floors. Smoke released near the entry routes was not drawn into the opening and the pressure tests showed that the sub-slab pressure was nearly the same as ambient pressures. These tests indicated that a pressure field had not been established. Pressure gauges were installed at various points in the drain tile collector pipes and relative vacuum measured while the fans were in operation. In some parts of the system, a good vacuum (e.g., < -25 Pa) was achieved. However, in large sections of the system, there was no measurable difference between the pressure in the drain tiles and ambient air. This revealed that the perimeter drain tiles connected to the modified venting system were severely blocked with silt and debris and major zones were, in effect, not connected to the vacuum system. These blockages drastically reduced the performance of the system.

After numerous attempts to remove the blockages from the perimeter drain tiles failed, a sub-slab depressurization (SSD) system was installed and activated. The SSD system incorporated two suction points through the interior basement floor slab into the underlying layer of aggregate and visible entry routes were sealed. Smoke testing of test holes and entry routes was again conducted. Visible air movement generated by the operation of the SSD system indicated that a negatively pressurized sub-slab region had been achieved.

Pressure and flow measurements taken at points along the systems using manometers did not indicate system imbalances, blockages, or excessive air leakage. A sub-slab pressure differential of approximately -15 Pa was found indicating a good pressure field extension under the slab (pressure differences less than -5 Pa would indicate a poor pressure field extension).

Air monitoring, using an organic vapor analyzer with a flame ionization detector), for the presence of methane indicated a significant reduction in indoor concentrations. Indoor concentrations of methane were reported to be below 100 ppm with few exceptions. In townhouses or clus-

INSTRUCTIONS

1. **REPORT NUMBER**
Insert the EPA report number as it appears on the cover of the publication.
2. **LEAVE BLANK**
3. **RECIPIENTS ACCESSION NUMBER**
Reserved for use by each report recipient.
4. **TITLE AND SUBTITLE**
Title should indicate clearly and briefly the subject coverage of the report, and be displayed prominently. Set subtitle, if used, in smaller type or otherwise subordinate it to main title. When a report is prepared in more than one volume, repeat the primary title, add volume number and include subtitle for the specific title.
5. **REPORT DATE**
Each report shall carry a date indicating at least month and year. Indicate the basis on which it was selected (e.g., *date of issue, date of approval, date of preparation, etc.*).
6. **PERFORMING ORGANIZATION CODE**
Leave blank.
7. **AUTHOR(S)**
Give name(s) in conventional order (*John R. Doe, J. Robert Doe, etc.*). List author's affiliation if it differs from the performing organization.
8. **PERFORMING ORGANIZATION REPORT NUMBER**
Insert if performing organization wishes to assign this number.
9. **PERFORMING ORGANIZATION NAME AND ADDRESS**
Give name, street, city, state, and ZIP code. List no more than two levels of an organizational hierarchy.
10. **PROGRAM ELEMENT NUMBER**
Use the program element number under which the report was prepared. Subordinate numbers may be included in parentheses.
11. **CONTRACT/GRANT NUMBER**
Insert contract or grant number under which report was prepared.
12. **SPONSORING AGENCY NAME AND ADDRESS**
Include ZIP code.
13. **TYPE OF REPORT AND PERIOD COVERED**
Indicate interim final, etc., and if applicable, dates covered.
14. **SPONSORING AGENCY CODE**
Insert appropriate code.
15. **SUPPLEMENTARY NOTES**
Enter information not included elsewhere but useful, such as: Prepared in cooperation with, Translation of, Presented at conference of, To be published in, Supersedes, Supplements, etc.
16. **ABSTRACT**
Include a brief (200 words or less) factual summary of the most significant information contained in the report. If the report contains a significant bibliography or literature survey, mention it here.
17. **KEY WORDS AND DOCUMENT ANALYSIS**
 - (a) **DESCRIPTORS** - Select from the Thesaurus of Engineering and Scientific Terms the proper authorized terms that identify the major concept of the research and are sufficiently specific and precise to be used as index entries for cataloging.
 - (b) **IDENTIFIERS AND OPEN-ENDED TERMS** - Use identifiers for project names, code names, equipment designators, etc. Use open-ended terms written in descriptor form for those subjects for which no descriptor exists.
 - (c) **COSATI FIELD GROUP** - Field and group assignments are to be taken from the 1965 COSATI Subject Category List. Since the majority of documents are multidisciplinary in nature, the Primary Field/Group assignment(s) will be specific discipline, area of human endeavor, or type of physical object. The application(s) will be cross-referenced with secondary Field/Group assignments that will follow the primary posting(s).
18. **DISTRIBUTION STATEMENT**
Denote **releasability** to the public or limitation for reasons other than security for example "Release Unlimited." Cite any availability to the public, with address and price.
19. & 20. **SECURITY CLASSIFICATION**
DO NOT submit classified reports to the National Technical Information service.
21. **NUMBER OF PAGES**
Insert the total number of pages, including this one and unnumbered pages, but exclude distribution list, if any.
22. **PRICE**
Insert the price set by the National Technical Information Service or the Government Printing Office, if known.