

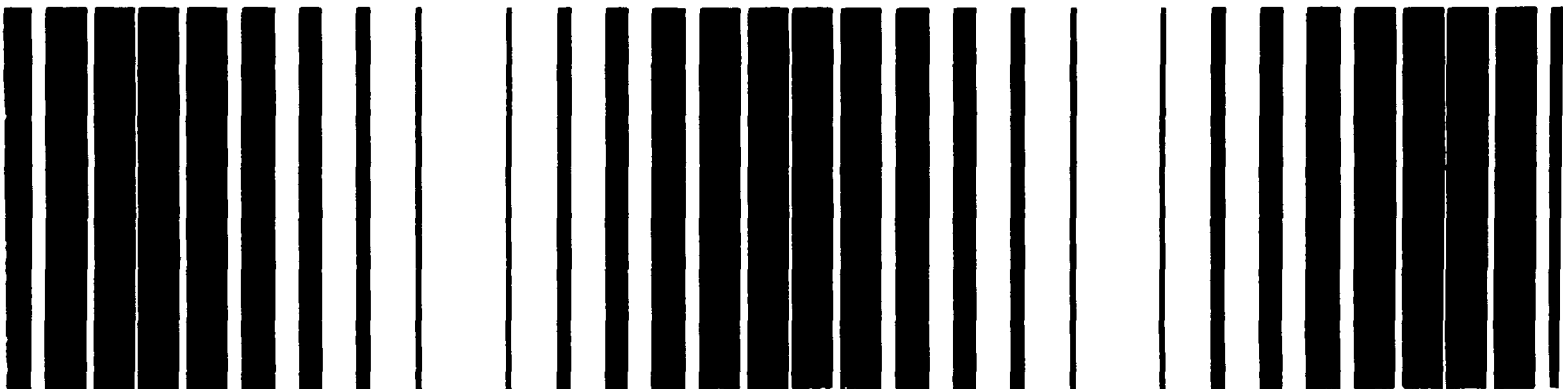

# Seminar Publication

## Design and Construction of RCRA/CERCLA Final Covers



## **Seminar Publication**

# **Design and Construction of RCRA/CERCLA Final Covers**

May 1991

Prepared for:

Center for Environmental Research Information  
U.S. Environmental Protection Agency  
26 West Martin Luther King Drive  
Cincinnati, OH 45268

U.S. Environmental Protection Agency  
Region 5, Library  
230 S. Dearborn Street  
Chicago, IL 60604

by:

Eastern Research Group, Inc.  
6 Whittemore Street  
Arlington, MA 02174



Printed on Recycled Paper

---

## **NOTICE**

The information in this document has been funded wholly or in part by the United States Environmental Protection Agency under Contract 68-C8-0011 to Eastern Research Group, Inc. It has been subject to the Agency's peer and administrative review, and it has been approved for publication as an EPA document. Mention of trade names or commercial products does not constitute endorsement or recommendation for use.

---

## **ACKNOWLEDGMENTS**

This seminar publication is based wholly on papers presented at the U.S. Environmental Protection Agency (EPA) Technology Transfer seminars on Design and Construction of Resource Conservation and Recovery Act (RCRA) and Comprehensive Environmental Response, Compensation, and Liability Act (CERCLA) Final Covers. These seminars were held in July and August 1990 in Atlanta, Georgia; Philadelphia, Pennsylvania; Boston, Massachusetts; Dallas, Texas; Kansas City, Missouri; Denver, Colorado; Newark, New Jersey; Chicago, Illinois; Seattle, Washington; and Oakland, California.

The authors are:

Robert E. Landreth, U.S. Environmental Protection Agency, Risk Reduction Engineering Laboratory (RREL), Cincinnati, Ohio (Chapters 1 and 5)

Dr. David E. Daniel, Department of Civil Engineering, University of Texas, Austin, Texas (Chapters 2 and 6)

Dr. Robert M. Koerner, Drexel University, Geosynthetic Research Institute, Philadelphia, Pennsylvania (Chapters 3, 4, and 7)

Dr. Paul R. Schroeder, Waterways Experiment Station, U.S. Army/Corps of Engineers, Vicksburg, Mississippi (Chapters 8, 9, and 10)

Dr. Gregory N. Richardson, GN Richardson & Associates, Raleigh, North Carolina (Chapters 11 and 12)

Daniel J. Murray of EPA's Center for Environmental Research Information directed the project, providing substantive guidance and review. David A. Carson of EPA's Risk Reduction Engineering Laboratory (RREL), Cincinnati, Ohio, Edwin F. Barth, Jr., of EPA's Center for Environmental Research Information, Cincinnati, Ohio, and Kenneth R. Skahn of EPA's Office of Solid Waste and Emergency Response peer reviewed the document. In addition, Frank Walberg, U.S. Army Corps of Engineers, served as a special reviewer. Susan Richmond, Linda Saunders, Denise Short, and Heidi Schultz of Eastern Research Group, Inc., provided editorial and production support.

---

## PREFACE

Cover systems are an essential part of all land disposal facilities. Covers control moisture infiltration from the surface into closed facilities and limit the formation of leachate and its migration to ground water. The Resource Conservation and Recovery Act (RCRA) Subparts G, K, and N form the basic requirements for cover systems being designed and constructed today. In addition, the Comprehensive Environmental Response, Compensation, and Liability Act (CERCLA) refers to RCRA Subtitle C regulations, and many states have their own more stringent requirements.

This seminar publication provides regulatory and design personnel with an overview of design, construction, and evaluation requirements for cover systems for RCRA/CERCLA waste management facilities. It offers practical and detailed information on the design and construction of final covers for both hazardous and nonhazardous waste landfills that comply with these requirements. As such it should be valuable both to U.S. Environmental Protection Agency (EPA) regional and state personnel involved in evaluating and permitting hazardous waste facility closures and to the environmental design and construction community.

Chapter One presents an overview of cover systems for waste management facilities, including recommended designs for RCRA Subtitle C and CERCLA facilities. Chapter Two describes soils used in typical cover systems and discusses critical parameters for soil liners as well as the effects of environmental impacts such as frost action and settlement. Chapter Three focuses on geosynthetic design and discusses geonet and geocomposite sheet drains, geopipe and geocomposite edge drains, geotextile filters, geogrid reinforcement, and methane gas vents. Chapter Four covers durability and aging of geomembranes, discussing in detail the mechanisms of degradation, as well as synergistic effects, and accelerated testing methods. Chapter Five presents alternative designs that meet the intent of regulations while adapting to site-specific concerns. Chapter Six discusses construction quality assurance for soils, including testing of materials, and construction quality assurance during all phases of site preparation and soil placement. Chapter Seven covers construction quality control for geomembranes from manufacture and shipment to placement of the geomembrane at the site. This chapter also presents destructive and nondestructive tests for solvent and thermal seams in the field. Chapter Eight discusses evaluation of liquid management systems for landfills using the Hydrologic Evaluation of Landfill Performance (HELP) model. Chapter Nine examines design parameter effects on cover performance. In Chapter Ten, gas management systems are discussed with attention to gas generation, migration, and control strategies. Chapter Eleven presents case studies of five closures, including RCRA industrial and commercial landfills, one CERCLA lagoon and one CERCLA landfill, and one municipal solid waste commercial landfill. The final chapter, Chapter Twelve, discusses postclosure monitoring of ground water, leachate, gas generation, subsidence, surface erosion, and air quality.

This publication is not a design manual nor does it include all of the latest knowledge concerning RCRA/CERCLA landfill cover systems; additional sources that provide more detailed information are available. Some of these sources are referred to in the text of the individual chapters. In addition, state and local authorities should be consulted for regulations and good management practices applicable to local areas.

## TABLE OF CONTENTS

		Page
1.	<b>OVERVIEW OF COVER SYSTEMS FOR WASTE MANAGEMENT FACILITIES</b> .....	1
	Introduction .....	1
	Recommended Design for Subtitle C Facilities .....	1
	Low Hydraulic Conductivity Layer .....	2
	Compacted Soil Component .....	2
	Geomembrane .....	2
	Drainage Layer .....	2
	Vegetation/Soil Top Layer .....	3
	Vegetation Layer .....	3
	Soil Layer .....	3
	Optional Layers .....	3
	Gas Vent Layer .....	3
	Biotic Layer .....	4
	Subtitle D Covers .....	4
	CERCLA Covers .....	5
	Applicability of RCRA Requirements .....	5
	Relevant and Appropriate RCRA Requirements .....	6
	State Equivalency .....	6
	Closure .....	6
	Applicability of Closure Requirements .....	6
	Relevant and Appropriate Closure Requirements .....	7
	References .....	7
2.	<b>SOILS USED IN COVER SYSTEMS</b> .....	9
	Introduction .....	9
	Typical Cover Systems .....	9
	Flow Rates Through Liners .....	9
	Critical Parameters for Soil Liners .....	12
	Materials .....	12
	Water Content .....	13
	Compactive Energy .....	14
	Size of Clods .....	16
	Bonding of Lifts .....	18
	Effects of Desiccation .....	18
	Effects of Frost Action .....	20
	Effects of Settlement .....	20
	Interfacial Shear .....	23
	Drainage Layers .....	24
	Summary .....	25
	References .....	25
3.	<b>GEOSYNTHETIC DESIGN FOR LANDFILL COVERS</b> .....	27
	General Comments on Design-by-Function .....	27

Geomembrane Design Concepts .....	27
Geomembrane Compatibility .....	27
Vapor Transmission .....	27
Biaxial Stresses via Subsidence .....	28
Planar Stresses via Friction .....	28
Geonet and Geocomposite Sheet Drain Design Concepts .....	28
Compatibility .....	28
Crush Strength .....	28
Flow Capability .....	29
Geopipe and Geocomposite Edge Drain Design Concepts .....	30
Compatibility .....	30
Crush Strength .....	30
Flow Rate .....	30
Geotextile Filter Design Considerations .....	30
Compatibility .....	30
Permeability .....	30
Geotextile Soil Retention .....	32
Geotextile Clogging Evaluation .....	32
Geogrid, or Geotextile, Cover Soil Reinforcement .....	32
Geotextile Methane Gas Vent .....	32
References .....	33
<b>4. DURABILITY AND AGING OF GEOMEMBRANES .....</b>	<b>35</b>
Polymers and Foundations .....	35
Mechanisms of Degradation .....	35
Ultraviolet Degradation .....	35
Radiation Degradation .....	35
Chemical Degradation .....	35
Swelling Degradation .....	36
Extraction Degradation .....	36
Delamination Degradation .....	36
Oxidation Degradation .....	36
Biological Degradation .....	36
Synergistic Effects .....	37
Elevated Temperature .....	37
Applied Stresses .....	37
Long Exposure .....	37
Accelerated Testing Methods .....	37
Stress Limit Testing .....	37
Rate Process Method for Pipe .....	37
Rate Process Method for Geomembranes .....	37
Arrhenius Modeling .....	37
Multi-Parameter Prediction .....	39
Summary and Conclusions .....	40
<b>5. ALTERNATIVE COVER DESIGNS .....</b>	<b>43</b>
Introduction .....	43
Subtitle C .....	43
Subtitle D .....	43
CERCLA .....	43
Other Cover Designs .....	44
References .....	45
<b>6. CONSTRUCTION QUALITY ASSURANCE FOR SOILS .....</b>	<b>47</b>
Introduction .....	47
Materials .....	47
Atterberg Limits .....	47

Percentage of Fines .....	47
Percentage of Gravel .....	47
Maximum Size of Particles or Clods .....	48
Requirements for Field Personnel .....	48
Frequency of Testing .....	48
Control of Subgrade Preparation .....	48
Soil Placement .....	48
Soil Compaction .....	49
Drainage Layers .....	49
Barrier Materials .....	49
Protection of a Completed Lift .....	55
Sampling Pattern .....	58
Test Pads .....	58
Outliers .....	58
Summary .....	61
Reference .....	61
<b>7. CONSTRUCTION QUALITY CONTROL FOR GEOMEMBRANES .....</b>	<b>65</b>
Preliminary Details .....	65
Manufacture .....	65
Fabrication of Panels .....	65
Storage at Factory .....	65
Shipment .....	65
Storage at Site .....	65
Subgrade Preparation .....	65
Deployment of the Geomembrane .....	66
Geomembrane Field Seams .....	66
Solvent Seams .....	66
Thermal Seams .....	66
Extrusion Seams .....	68
Destructive Seam Tests .....	68
Nondestructive Seam Tests .....	69
Penetrations, Appurtenances, and Miscellaneous Details .....	70
Reference .....	71
<b>8. HYDROLOGIC EVALUATION OF LANDFILL PERFORMANCE (HELP)</b>	
<b>MODEL FOR DESIGN AND EVALUATION OF LIQUIDS</b>	
<b>MANAGEMENT SYSTEMS .....</b>	<b>73</b>
Introduction .....	73
Overview .....	73
Covers .....	73
Leachate Collection/Liner Systems .....	74
HELP Model .....	75
Background .....	75
Process Simulation Methods .....	76
Infiltration .....	76
Evapotranspiration .....	77
Subsurface Water Routing .....	78
Vegetative Growth .....	79
Accuracy .....	79
Input Requirements .....	80
Climatological Data .....	80
Soil and Design Data .....	80
Output Description .....	81
Example Application .....	81
References .....	84

<b>9.</b>	<b>SENSITIVITY ANALYSIS OF HELP MODEL PARAMETERS</b> .....	97
	Introduction .....	97
	Comparison of Typical Cover Systems .....	97
	Design Parameters .....	97
	Results .....	98
	Effects of Vegetation .....	98
	Effects of Topsoil Thickness .....	99
	Effects of Topsoil Type .....	102
	Use of Lateral Drainage Layer .....	103
	Effects of Climate .....	103
	Vegetative Layer Properties	
	Effects of SCS Runoff Curve Number .....	103
	Effects of Evaporative Depth .....	104
	Effects of Drainable Porosity .....	104
	Effects of Plant Available Water Capacity .....	105
	Liner/Drain Systems .....	106
	Clay Liner/Drain Systems .....	107
	Geomembrane/Drain Systems .....	109
	Double Liner Systems .....	111
	Summary of Sensitivity Analysis .....	115
	References .....	116
<b>10.</b>	<b>GAS MANAGEMENT SYSTEMS</b> .....	117
	Gas Generation .....	117
	Gas Migration .....	117
	Gas Control Strategies .....	118
	References .....	121
<b>11.</b>	<b>CASE STUDIES—RCRA/CERCLA CLOSURES</b> .....	123
	Introduction .....	123
	Case 1: RCRA Commercial Landfill .....	123
	Calculation of Localized Subsidence .....	123
	Gas Collection Systems .....	124
	Case 2: RCRA Industrial Landfill .....	125
	Case 3: CERCLA Lagoon Closure .....	129
	Case 4: CERCLA Landfill Closure .....	132
	Case 5: MSW Commercial Landfill .....	135
	Conclusions .....	138
	References .....	138
	Additional References .....	140
<b>12.</b>	<b>POSTCLOSURE MONITORING</b> .....	141
	Introduction .....	141
	Ground-Water Monitoring .....	141
	Leachate Monitoring .....	141
	Gas Generation .....	143
	Subsidence Monitoring .....	144
	Surface Erosion .....	145
	Air Quality Monitoring .....	145
	References .....	145
<b>Appendix A</b>		
	Stability and Tension Considerations Regarding Cover Soils on Geomembrane-Lined Slopes .....	A-1
<b>Appendix B</b>		
	Long-term Durability and Aging of Geomembranes .....	B-1

## LIST OF FIGURES

Figure		Page
1-1	EPA-recommended landfill cover design .....	2
1-2	EPA-recommended landfill cover with options .....	4
2-1	Soil liner, geomembrane liner, and composite liner .....	10
2-2	Soil liner and composite liner .....	12
2-3	Effect of bentonite upon the hydraulic conductivity of a bentonite-amended soil .....	14
2-4	Hydraulic conductivity and dry unit weight versus molding water content .....	15
2-5	Highly plastic soil compacted with standard Proctor procedures at a water content of 12% .....	16
2-6	Highly plastic soil compacted with standard Proctor procedures at a water content of 16% .....	16
2-7	Highly plastic soil compacted with standard Proctor procedures at a water content of 20% .....	16
2-8	Rototiller used to mix soil .....	17
2-9	Blades and teeth on rototiller .....	17
2-10	Influence of compactive effort upon hydraulic conductivity and dry unit weight .....	19
2-11	Road recycler used to pulverize clods of soil .....	20
2-12	Passage of road recycler over loose lift of mudstone to reduce size of chunks of mudstone .....	21
2-13	Effect of imperfect bonding of lifts on hydraulic performance of soil liner .....	21
2-14	Example of heavy footed roller with long feet .....	22
2-15	Effect of desiccation upon the hydraulic conductivity of compacted clay .....	23
2-16	Relationship between distortion and tensile strain .....	24
2-17	Relationship between shearing characteristics of compacted soils and conditions of compaction .....	25
3-1	Required strength .....	28
3-2	Response of common geomembranes to the three-dimensional geomembrane tension test .....	29
3-3	Required geomembrane tension .....	29
3-4	Common crush strength behavior for geonets and geocomposites .....	30
3-5	ASTM D-4716 flow rate test .....	31
3-6	Crush strength of geopipe and geocomposite edge drain cores .....	32
3-7	Required strength of geogrid for cover soil reinforcement .....	33
3-8	Allowable gas flow as adapted from ASTM D-4716 .....	34
4-1	Wavelength spectrum of visible and ultraviolet radiation .....	36
4-2	Stress limit testing for plastic pipe .....	38
4-3	Rate process method for testing pipe .....	38
4-4	Rate process method for testing geomembranes .....	39
4-5	Testing device for Arrhenius modeling .....	39
4-6	Reaction rate for impact testing of polyethylene shielding .....	40
4-7	Experimental and field-measured response curves for multi-parameter lifetime prediction .....	41
5-1	Resistive layer barrier .....	44
5-2	Conductive layer barrier .....	45
5-3	Side view of bioengineered lysimeter. Surface runoff is collected from both engineered surface and soil surface. Soil moisture content is measured with neutron probe. Water table is measured in well .....	45
6-1	Traditional method for specification of acceptable water contents and dry unit weights .....	50
6-2	Data from Mitchell et al. for silty clay compacted with impact compaction .....	51
6-3	Compaction data for silty clay (6); solid symbols represent specimens with hydraulic conductivity less than or equal to $1 \times 10^{-7}$ cm/s and open symbols represent specimens with hydraulic conductivity $>1 \times 10^{-7}$ cm/s .....	52
6-4	Contours of constant hydraulic conductivity for silty clay compacted with kneading compaction .....	52
6-5	Recommended procedure .....	53
6-6	Use of hydraulic conductivity and shear strength data to define a single, overall acceptable zone .....	55
6-7	Possible approaches for specifying lower limit of Acceptable Zone: (A) minimum degree of saturation, S; and (B) line of optimums .....	56
6-8	Compaction curves for Type A soil from East Borrow area at Oak Ridge Y-12 operations project .....	57
6-9	Hydraulic conductivity versus molding water content for Type A soil from East Borrow area at Oak Ridge Y-12 operations project .....	57
6-10	Acceptable zone for Type A soil from East Borrow area at Oak Ridge Y-12 operations project .....	58

6-11	Pushing of thin-walled sampling tube with a backhoe .....	59
6-12	Tilting of sampling tube during push.....	59
6-13	Placement of hydraulic jack on top of sampling tube .....	60
6-14	Use of backhoe as a reaction for hydraulic jack .....	60
6-15	Checklist of critical variables for CQA of low hydraulic conductivity compacted soil used in a cover system.....	62
6-16	Checklist of critical variables for CQA of drainage materials used in a cover system.....	63
7-1	Shear and peel test for geomembrane seams .....	68
8-1	Cover and liner edge configuration with example toe drain.....	73
8-2	Schematic of a single clay liner system for a landfill .....	74
8-3	Schematic of a double liner and leak detection system for a landfill .....	75
8-4	Simulation processes in the HELP model .....	76
8-5	Typical hazardous waste landfill profile .....	81
8-6	Completed data form for landfill materials and design .....	82
8-7	Completed data form for climatological data .....	84
8-8	Example output.....	85
9-1	Cover designs for sensitivity analysis.....	99
9-2	Bar graph for three-layer cover design showing effect of surface vegetation, topsoil type, and location.....	100
9-3	Bar graph for two-layer cover design showing effect of topsoil depth, surface vegetation, and location.....	100
9-4	Effect of saturated hydraulic conductivity on lateral drainage and percolation.....	109
9-5	Effect of ratio of drainage layer saturated hydraulic conductivity to soil liner saturated hydraulic conductivity on ratio of lateral drainage to percolation for a steady-state (SS) inflow of 20 cm/yr(8 in./yr).....	110
9-6	Effect of ratio of drainage layer saturated hydraulic conductivity to soil liner saturated hydraulic conductivity on ratio of lateral drainage to percolation for an unsteady inflow of 127 cm/yr (50 in./yr).....	110
9-7	Effect of ratio of drainage length to drainage layer slope on the average saturated depth in drainage layer ( $KD=10^{-2}$ cm/s) above a soil liner ( $KP=10^{-7}$ cm/s) under a steady-state inflow rate of 20 cm/yr(8 in./yr).....	111
9-8	Synthetic liner leakage fraction as a function of density of holes, size of holes, head on the liner and saturated hydraulic conductivity of the liner .....	112
9-9	Effect of leakage fraction on system performance .....	112
9-10	Liner designs .....	113
9-11	Percent of inflow to primary leachate collection layer discharging from leakage detection layer and bottom liner for double liner systems C and E .....	114
9-12	Percent of inflow to primary leachate collection layer discharging from leakage detection layer and bottom liner for double liner systems D and F.....	114
10-1	Cover with gas vent outlet and vent layer.....	118
10-2	Gravel vent and gravel-filled trench used to control lateral gas movement in a sanitary landfill .....	119
10-3	Typical trench barrier system .....	119
10-4	Gas control barriers .....	120
10-5	Gas extraction well for landfill gas control .....	121
10-6	Gas extraction well design.....	122
11-1	Case 1 - Cap profile and geometry.....	124
11-2	Case 1 - General subsidence model .....	125
11-3	Case 1 - Cumulative subsidence .....	126
11-4	Case 1 - Geomembrane strains in trench subsidence .....	126
11-5	Case 1 - Uniaxial and biaxial geomembrane response .....	127
11-6	Case 1 - Subsidence strain in soil barrier.....	127
11-7	Case 1 - Ultimate tensile strain in clays.....	128
11-8	Case 1 - Gas collector system.....	129
11-9	Case 2 - Cap profile and geometry.....	130
11-10	Case 2 - Direct shear data: texture HDPE.....	130
11-11	Case 2 - Slope factors for soil loss evaluation.....	131
11-12	Case 2 - Sideslope armoring scheme .....	131

---

11-13	Case 3 - Cap profile and geometry .....	132
11-14a	Case 3 - Placement of geogrid over geomembrane .....	133
11-14b	Case 3 - Placement of drainage layer over geogrid.....	133
11-15a	Case 3 - Outlet detail for sideslope toe surface water drainage layer .....	134
11-15b	Case 3 - Erosion at drainage layer outlet.....	134
11-16	Case 4 - Cap profile and geometry .....	135
11-17a	Case 4 - Placement of geotextile on asphalt emulsion .....	136
11-17b	Case 4 - Placement of chip seal on geotextile.....	136
11-18	Case 5 - Cap profile and geometry .....	137
11-19	Case 5 - Profile showing MSW subcells .....	138
11-20	Case 5 - Gas collector well array .....	139
11-21	Case 5 - Perimeter gas monitoring well.....	139
12-1	Monitoring well configuration .....	142
12-2	Monitoring interbedded aquifer .....	142
12-3	Impact of biological growth on filters.....	143
12-4	Gas generation versus time .....	143

---

## LIST OF TABLES

Table	Page
2-1	Calculated Flow Rates through Soil Liners with 30 cm of Water Ponded on the Liner ..... 10
2-2	Calculated Flow Rates through a Geomembrane with a Head of 30 cm of Water above the Geomembrane ..... 10
2-3	Calculated Flow Rates for Composite Liners with a Head of Water of 30 cm ..... 11
2-4	Calculated Flow Rates for Soil Liners, Geomembrane Liners, and Composite Liners ..... 13
2-5	Effect of Size of Clods during Processing of Soil upon Hydraulic Conductivity of Soil after Compaction ..... 18
3-1	Customary Primary Functions of Geosynthetics Used in Waste Containment Systems ..... 27
4-1	Typical Formulations of Geomembranes ..... 35
6-1	Recommended Materials Tests for Barrier Layers ..... 48
6-2	Recommended Tests and Observations on Subgrade Preparation ..... 49
6-3	Recommended Tests and Observations on Compacted Soil for Barrier Layers ..... 54
7-1	Overview of Geomembrane Field Seams ..... 67
7-2	Overview of Nondestructive Seam Tests ..... 69
9-1	Parameters Selected for Sensitivity Analysis ..... 97
9-2	Climatological Regimes ..... 98
9-3	Effects of Climate and Vegetation ..... 101
9-4	Effects of Climate and Topsoil Thickness ..... 101
9-5	Effects of Climate and Topsoil Types ..... 102
9-6	Effects of Evaporative Depth and Runoff Curve Number ..... 105
11-1	Soil Texture Constant for Soil Loss Evaluation ..... 131
12-1	Threshold Limits of Air Contamination ..... 144

---

## CHAPTER 1

### OVERVIEW OF COVER SYSTEMS FOR WASTE MANAGEMENT FACILITIES

#### INTRODUCTION

Proper closure is essential to complete a filled hazardous waste landfill. Research has established minimum requirements needed to meet the stringent, necessary, closure regulations in the United States. In designing the landfill cover, the objective is to limit the infiltration of water to the waste so as to minimize creation of leachate that could possibly escape to ground-water sources.

Minimizing leachates in a closed waste management unit requires that liquids be kept out and that the leachate that does exist be detected, collected, and removed. Where the waste is above the ground-water zone, a properly designed and maintained cover can prevent (for practical purposes) water from entering the landfill and, thus, minimize the formation of leachate.

The cover system must be devised at the time the site is selected and the plan and design of the landfill containment structure is chosen. The location, the availability of soil with a low permeability or hydraulic conductivity, the stockpiling of good topsoil, the availability and use of geosynthetics to improve performance of the cover system, the height restrictions to provide stable slopes, and the use of the site after the postclosure care period are typical considerations. The goals of the cover system are to minimize further maintenance and to protect human health and the environment.

Subparts G, K, and N of the Resource Conservation and Recovery Act (RCRA) Subtitle C regulations form the basic requirements for cover systems being designed and constructed today. Comprehensive Environmental Response, Compensation, and Liability Act (CERCLA) regulations refer to the RCRA Subtitle C regulations but other criteria, primarily approved state requirements, also have to be evaluated for applicability. The proposed RCRA Subtitle D regulations base cover requirements primarily on the hydraulic conductivity of the bottom liner.

#### RECOMMENDED DESIGN FOR SUBTITLE C FACILITIES

After the hazardous waste management unit is closed, the U.S. Environmental Protection Agency (EPA) recommends (1) that the final cover (Figure 1-1) consist of, from bottom to top:

1. *A Low Hydraulic Conductivity Geomembrane/Soil Layer.* A 60-cm (24-in.) layer of compacted natural or amended soil with a hydraulic conductivity of  $1 \times 10^{-7}$  cm/sec in intimate contact with a minimum 0.5-mm (20-mil) geomembrane liner.
2. *A Drainage Layer.* A minimum 30-cm (12-in.) soil layer having a minimum hydraulic conductivity of  $1 \times 10^{-2}$  cm/sec, or a layer of geosynthetic material having the same characteristics.
3. *A Top, Vegetation/Soil Layer.* A top layer with vegetation (or an armored top surface) and a minimum of 60 cm (24 in.) of soil graded at a slope between 3 and 5 percent.

Because the design of the final cover must consider the site, the weather, the character of the waste, and other site-specific conditions, these minimum recommendations may be altered providing the alternative design is equivalent to the EPA-recommended design or will meet the intent of the regulations. EPA encourages design innovation and will accept an alternative design provided the owner or operator demonstrates the new design's equivalency. For example, in extremely arid regions, a gravel top surface might compensate for reduced vegetation, or the middle drainage layer might be expendable. Where burrowing animals might damage the geomembrane/low hydraulic conductivity soil layer, a biotic barrier layer of large-sized cobbles may be needed above it. Where the type of waste may create gases, soil or geosynthetic vent structures would need to be included.

Settlement and subsidence should be evaluated for all covers and accounted for in the final cover plans. The current operating procedures for RCRA Subtitle C facilities (e.g., banning of liquids and partially filled drums of liquids) usually do not present major settlement or subsidence issues. For RCRA Subtitle D facilities, however, the normal decomposition of the waste will invariably result in settlement and subsidence. Settlement and subsidence can be significant, and special care may be required in designing the final cover system. The cover design process should consider the stability of all the waste layers and their intermediate soil covers, the soil and foundation materials beneath the landfill site, all the

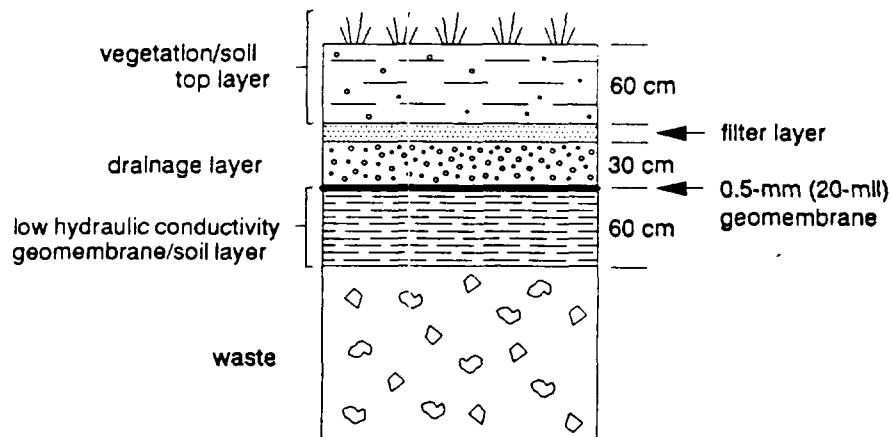

Figure 1-1. EPA-recommended landfill cover design (1).

liner and leachate collection systems, and all the final cover components. When a significant amount of settlement and subsidence is expected within 2 to 5 years of closure, an interim cover that protects human health and the environment might be proposed. Then when settlement/subsidence is essentially complete, the interim cover could be replaced or incorporated into a final cover.

**Low Hydraulic Conductivity Layer**

The function of the composite low hydraulic conductivity layer, composed of soil and a geomembrane, is to prevent moisture movement downward from the overlying drainage layer.

**Compacted Soil Component**

EPA recommends a test pad be constructed before the low hydraulic conductivity soil layer is put in place to demonstrate that the compacted soil component can achieve a maximum hydraulic conductivity of  $1 \times 10^{-7}$  cm/sec. To ensure that the design specifications are attainable, a test pad uses the same soil, equipment, and procedures to be used in constructing the low hydraulic conductivity layer. For Subtitle D facilities, the test fill should be constructed on part of the solid waste material to determine the impact of compacting soil on top of less resistive municipal solid waste.

The low hydraulic conductivity soil component placed over the waste should be at least 60-cm (24-in.) deep; free of detrimental rock, clods, and other soil debris; have an upper surface with a 3 percent maximum slope; and be below the maximum frost line. The surface should be smooth so that no small-scale stress points are created for the geomembrane.

In designing the low hydraulic conductivity layer, the causes of failure—subsidence, desiccation cracking, and freeze/thaw cycling—must be considered. Most of the settling will have taken place by the time the cover is put into place, but there is still a potential for further subsidence. Although estimating this potential is difficult, in-

formation about voids and compressible materials in the underlying waste will aid in calculating subsidence.

A soil with low cracking potential should be selected for the soil component of the low hydraulic conductivity layer. The potential for desiccation cracking of compacted clay depends on the physical properties of the compacted clay, its moisture content, the local climate, and the moisture content of the underlying waste.

Because freeze/thaw conditions can cause soil cracking, lessen soil density, and lessen soil strength, this entire low hydraulic conductivity/geomembrane layer should be below the depth of the maximum frost penetration. In northern areas, then, the maximum depth of the top vegetation/soil layer would be greater than the recommended minimum of 60 cm (24 in.).

Penetrating this low hydraulic conductivity/geomembrane soil layer with gas vents or drainage pipes should be kept to a minimum. Where a vent is necessary, there should be a secure, liquid-tight seal between the vent and the geomembrane. If settlement or subsidence is a major concern, this seal must be designed for flexibility to allow for vertical movement.

**Geomembrane**

The geomembrane placed on the smooth, even, low hydraulic conductivity layer should be at least 0.5-mm (20-mils) thick. The minimum slope surface should be 3 percent after any settlement of the soil layer or sub-base material. Stress situations such as bridging over subsidence and friction between the geomembrane and other cover components (i.e., compacted soil, geosynthetic drainage material, etc.), especially on side slopes, will require special laboratory tests to ensure the design has incorporated site-specific materials.

**Drainage Layer**

The drainage layer should be designed to minimize the time the infiltrated water is in contact with the bottom, low hydraulic conductivity layer and, hence, to lessen the

potential for the water to reach the waste (see Figure 1-1). Water that filters through the top layer is intercepted and rapidly moved to an exit drain, such as by gravity flow to a toe drain.

If the granular material in the drainage layer is sand, the minimum requirements are that it should be at least 30-cm (12-in.) deep with a hydraulic conductivity of  $1 \times 10^{-2}$  cm/sec or greater. Drainage pipes should not be placed in any manner that would damage the geomembranes.

If geosynthetic materials are used in the drainage layer, the same physical and hydraulic requirements should be met, e.g., equivalency in hydraulic transmissivity, longevity, compatibility with geomembrane, compressibility, conformance to surrounding materials, and resistance to clogging. Geosynthetic materials are gaining increased use and understanding of their performance. Manufacturers are also continuing to improve the basic resin properties to improve their long-term durability. The net result is that organizations such as the American Society of Testing Materials (ASTM) and the Geosynthetic Research Institute (GRI), Drexel University, Philadelphia, Pennsylvania, are continually developing new evaluation procedures to better correlate with design and field experiences.

Between the bottom of the top-layer soil and the drainage-layer sand, a granular or geosynthetic filter layer should be included to prevent the drainage layer from clogging by top-layer fines. The criteria established for the grain size of granular filter sand are designed to minimize the migration of fines from the overlying top layer into the drainage layer. (For information on filter criteria, refer to the EPA Technical Guidance Document [1].) ASTM test procedures have also been established to evaluate particulate clogging potential of geosynthetics.

### **Vegetation/Soil Top Layer**

#### **Vegetation Layer**

The upper layer of the two-component top layer (Figure 1-1) should be vegetation (or another surface treatment) that will allow runoff from major storms while inhibiting erosion. Vegetation over soil (part of which is topsoil) is the preferred system, although, in some areas, vegetation may be unsuitable.

The temperature- and drought-resistant vegetation should be indigenous; have a root system that does not extend into the drainage layer; need no maintenance; survive in low-nutrient soil; and have sufficient density to control the rate of erosion to the recommended level of less than 5.5 MT/ha/yr (2 ton/acre/yr).

The surface slope should be the same as that of the underlying soils; at least 3 percent but no greater than 5 percent. To support the vegetation, this top layer should be at least 60-cm (24-in.) deep and include at least 15-

cm (6-in.) of topsoil. To help the plant roots develop, this layer should not be compacted. In some northern climates, this top layer may need to be more than the minimum 60 cm (24 in.) to ensure that the bottom low hydraulic conductivity layer remains below the frost zone.

Where vegetation cannot be maintained, particularly in arid areas, other materials should be selected to prevent erosion and to allow for surface drainage. Asphalt and concrete are apt to deteriorate because of thermal-caused cracking or deform because of subsidence. Therefore, a surface layer 13 to 25-cm (5 to 10-in.) deep of 5 to 10-cm (2 to 4-in.) stones or cobbles would be more effective. Although cobbles are a one-way valve and allow rain to infiltrate, this phenomenon would be of less concern in arid areas. In their favor, cobbles resist wind erosion well.

#### **Soil Layer**

The soil in this 60-cm (24-in.) top layer should be capable of sustaining nonwoody plants, have an adequate water-holding capacity, and be sufficiently deep to allow for expected, long-term erosion losses. A medium-textured soil such as a loam would fit these requirements. If the landfill site has sufficient topsoil, it should be stockpiled during excavation for later use.

The final slopes of the cover should be uniform and at least 3 percent, and should not allow erosion rills and gullies to form. Slopes greater than 5 percent will promote erosion unless controls are built in to limit erosion to less than 5.5 MT/ha/yr (2 ton/acre/yr). The U.S. Department of Agriculture's (USDA's) Universal Soil Loss Equation is recommended as the tool to evaluate erosion potential.

#### **Optional Layers**

Although other layers may be needed on a site-specific basis, the common optional layers are those for gas vents and for a biotic barrier layer (Figure 1-2).

#### **Gas Vent Layer**

The gas vent layer should be at least 30-cm (12-in.) thick and be above the waste and below the low hydraulic conductivity layer. Coarse-grained porous material, similar to that used in the drainage layer or equivalent-performing synthetic material, can be used.

The perforated, horizontal venting pipes should channel gases to a minimum number of vertical risers located at a high point (in the cross section) to promote gas ventilation. To prevent clogging, a granular or geotextile filter may be needed between the venting and the low hydraulic conductivity soil geomembrane layers.

As an alternative, vertical, standpipe gas collectors can be built up as the landfill is filled with waste. These standpipes, which may be constructed of concrete, can be 30 cm (12 in.) or more in diameter and may also be used to provide access to measure leachate levels in the landfill.

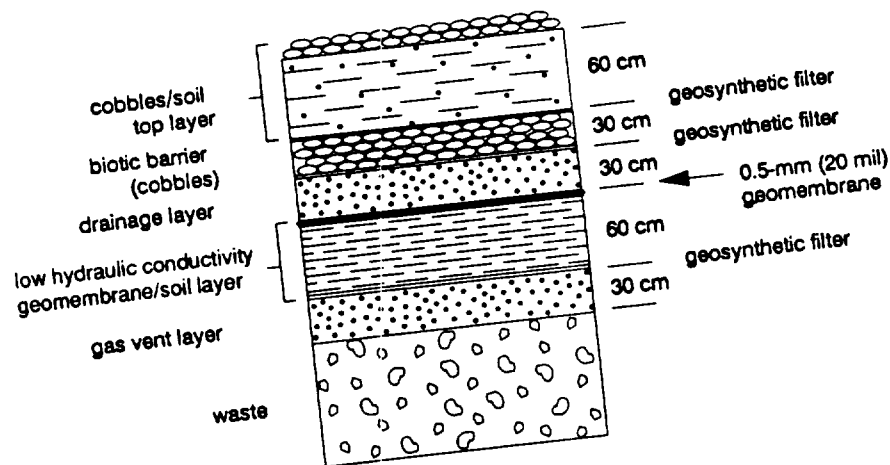

Figure 1-2. EPA-recommended landfill cover with options (1).

### Biotic Layer

Plant roots or burrowing animals (collectively called biointruders) may disrupt the drainage and the low hydraulic conductivity layers to interfere with the drainage capability of the layers. A 90-cm (3-ft.) biotic barrier of cobbles directly beneath the top vegetation layer may stop the penetration of some deep-rooted plants and the invasion of burrowing animals. Most research on biotic barriers has been done in, and is applicable to, arid areas. Geosynthetic products that incorporate a time-released herbicide into the matrix or on the surface of the polymer may also be used to retard plant roots. The longevity of these products requires evaluation if the cover system is to serve for longer than 30 to 50 years.

### SUBTITLE D COVERS

The cover system in nonhazardous waste landfills (Subtitle D) will be a function of the bottom liner system and the liquids management strategy for the specific site. If the bottom liner system contains a geomembrane, then the cover system should contain a geomembrane to prevent the "bathtub" effect. When the bottom liner is less permeable than the cover system, e.g., geomembrane on the bottom and natural soil on the top, the facility will "fill up" with infiltration water (through the cover) unless an active leachate removal system is in place. Likewise, if the bottom liner system is a natural soil liner, then the cover system barrier should be hydraulically equivalent to or less than the bottom liner system. A geomembrane used in the cover will prevent the infiltration of moisture to the waste below and may contribute to the collection of waste decomposition gases, therefore necessitating a gas-vent layer.

There are at least two options to consider under a liquids management strategy, mummification and recirculation. In the *mummification* approach the cover system is designed, constructed, and maintained to prevent moisture infiltration to the waste below. The waste will even-

tually approach and remain in a state of "mummification" until the cover system is breached and moisture enters the landfill. A continual maintenance program is necessary to maintain the cover system in a state of good repair so that the waste does not decompose to generate leachate and gas.

The *recirculation* concept results in the rapid physical, chemical, and biological stabilization of the waste. To accomplish this, a moisture balance is maintained with the landfill that will accelerate these stabilization processes. This approach requires geomembranes in both bottom and top control systems to prevent leachate from getting out and excess moisture from getting in. In addition, the system needs a leachate collection and removal system on the bottom and a leachate injection system on the top, maintenance of this system for a number of years (depending on the size of the facility), and a collection system to remove the waste decomposition gases. In a modern landfill facility, all of the above, except the leachate injection system, would probably be available. The benefit of this approach is that, stabilization, the facility should not require further maintenance. A more important advantage is that the decomposed and stabilized waste may be removed and used like compost, the plastics and metals could be recycled, and the site used again. If properly planned and operated in this manner, several cells could serve a community's waste management needs.

A natural soil material may be used in a cover when the bottom liner system is also natural soils. Regulatory requirements will permit. A matrix of characteristics (using either USDA or USCS) and health characteristics, and site usage characteristics can be determined to provide information on which soil or combination of soils will be the most beneficial.

Health considerations demand the evaluation of the type to minimize vector breeding areas and exposure to animals. The soil should minimize r

filtration (best accomplished by fine grain soils) while allowing gas movement (coarse grain soils are best). This desired combination of seemingly opposite soil properties suggests a layered system. The soil should also minimize fire potential.

Aesthetic considerations include minimizing blowing of paper and other waste, controlling odors, and providing a slightly appealing appearance. All landfill operators strive to be good neighbors and these considerations are very important for community relations.

The landfill site may be used for a variety of activities after closure. For this reason, cover soils should minimize settlement and subsidence, maximize compaction, assist vehicle support and movement, allow for equipment workability under all weather conditions, and allow healthy vegetation to grow. The future use of the site should be considered at the initial landfill design stages so that appropriate end-use design features can be incorporated into the cover during the active life of the facility.

## CERCLA COVERS

The Superfund Amendments and Reauthorization Act of 1986 (SARA) adopts and expands a provision in the 1985 National Contingency Plan (NCP) that remedial actions must at least attain applicable or relevant and appropriate requirements (ARARs). Section 121(d) of CERCLA, as amended by SARA, requires attainment of federal ARARs and of state ARARs in state environmental or facility siting laws when the state requirements are promulgated, more stringent than federal laws, and identified by the state in a timely manner.

CERCLA facilities require information on whether or not the site is under the jurisdiction of RCRA regulations. The cover system design can then be developed based on appropriate regulations.

RCRA Subtitle C requirements for treatment, storage, and disposal facilities (TSDFs) will frequently be ARARs for CERCLA actions, because RCRA regulates the same or similar wastes as those found at many CERCLA sites, covers many of the same activities, and addresses releases and threatened releases similar to those found at CERCLA sites. When RCRA requirements are ARARs, only the *substantive requirements* of RCRA must be met if a CERCLA action is to be conducted on site. Substantive requirements are those requirements that pertain directly to actions or conditions in the environment. Examples include performance standards for incinerators (40 CFR 264.343), treatment standards for land disposal of restricted waste (40 CFR 268), and concentration limits, such as maximum contaminant levels (MCLs). On-site actions do not require RCRA permits or compliance with *administrative requirements*. Administrative requirements are those mechanisms that facilitate the implementation of the substantive requirements of a statute or regulation. Examples include the requirements for

preparing a contingency plan, submitting a petition to delist a listed hazardous waste, recordkeeping, and consultations. CERCLA actions to be conducted off site must comply with both substantive and administrative RCRA requirements.

## APPLICABILITY OF RCRA REQUIREMENTS

RCRA Subtitle C requirements for the treatment, storage, and disposal of hazardous waste are applicable for a Superfund remedial action if the following conditions are met (2):

1. The waste is a RCRA hazardous waste, and either:
2. The waste was initially treated, stored, or disposed of after the effective date of the particular RCRA requirement

or

The activity at the CERCLA site constitutes treatment, storage, or disposal, as defined by RCRA.

For RCRA requirements to be applicable, a Superfund waste must be determined to be a listed or characteristic hazardous waste under RCRA. A waste that is hazardous because it once exhibited a characteristic (or a media containing a waste that once exhibited a characteristic) will not be subject to Subtitle C regulation if it no longer exhibits that characteristic. A listed waste may be delisted if it can be shown not to be hazardous based on the standards in 40 CFR 264.22. If such a waste will be shipped off site, it must be delisted through a rulemaking process. To delist a RCRA hazardous waste that will remain on site at a Superfund site, however, only the substantive requirements for delisting must be met.

Any environmental media (i.e., soil or ground water) contaminated with a listed waste is not a hazardous waste, but must be managed as such until it no longer contains the listed waste—generally when constituents from the listed waste are at health-based levels. Delisting is not required.

To determine whether a waste is a listed waste under RCRA, it is often necessary to know the source of that waste. For any Superfund site, if determination cannot be made that the contamination is from a RCRA hazardous waste, RCRA requirements will not be applicable. This determination can be based on testing or on best professional judgment (based on knowledge of the waste and its constituents).

A RCRA requirement will be applicable if the hazardous waste was treated, stored, or disposed of after the effective date of the particular requirement. The RCRA Subtitle C regulations that established the hazardous waste management system first became effective on November 19, 1980. Thus, RCRA regulations will not be applicable to wastes disposed of before that date, unless the CERCLA action itself constitutes treatment, storage, or disposal (see below). Additional standards have been is-

sued since 1980; therefore, applicable requirements may vary somewhat, depending on the specific date on which the waste was disposed.

RCRA requirements for hazardous wastes will also be applicable if the response activity at the Superfund site constitutes treatment, storage, or disposal, as defined under RCRA. Because remedial actions frequently involve grading, excavating, dredging, or other measures that disturb contaminated material, activities at Superfund sites may constitute disposal, or placement, of hazardous waste. Disposal of hazardous waste, in particular, triggers a number of significant requirements, including closure requirements and land disposal restrictions, which require treatment of wastes prior to land disposal. (See *Guides on Superfund Compliance with Land Disposal Restrictions*, OSWER Directives 9347.3-01FS through 9237.3-06FS, for a detailed description of these requirements.)

EPA has determined that disposal occurs when wastes are placed in a land-based unit. However, movement within a unit does not constitute disposal or placement, and at CERCLA sites, an area of contamination (AOC) can be considered comparable to a unit. Therefore, movement within an AOC does not constitute placement.

#### **Relevant and Appropriate RCRA Requirements**

RCRA requirements that are not applicable may, nonetheless, be relevant and appropriate, based on site-specific circumstances. For example, if the source or prior use of a CERCLA waste is not identifiable, but the waste is similar in composition to a known, listed RCRA waste, the RCRA requirements may be potentially relevant and appropriate, depending on other circumstances at the site. The similarity of the waste at the CERCLA site to RCRA waste is not the only, nor necessarily the most important, consideration in the determination. An in-depth, constituent-by-constituent analysis is generally neither necessary nor useful, since most RCRA requirements are the same for a given activity or unit, regardless of the specific composition of the hazardous waste.

The determination of relevance and appropriateness of RCRA requirements is based instead on the circumstances of the release, including the hazardous properties of the waste, its composition and matrix, the characteristics of the site, the nature of the release or threatened release from the site, and the nature and purpose of the requirement itself. Some requirements may be relevant and appropriate for certain areas of the site, but not for other areas. In addition, some RCRA requirements may be relevant and appropriate at a site, while others are not, even for the same waste. For example, at one site minimum technology requirements may be considered relevant and appropriate for an area receiving waste because of the high potential for migration of contaminants in hazardous levels to ground water, but not for another area that contains relatively immobile waste. Land dis-

posal restrictions at the same site may not be relevant and appropriate for either area because the required treatment technology is not appropriate, given the matrix of the waste. Only those requirements that are determined to be both relevant and appropriate must be attained.

#### **State Equivalency**

A state may be authorized to administer the RCRA hazardous waste program in lieu of the federal program provided the state has equivalent authority. Authorization is granted separately for the basic RCRA Subtitle C program, which includes permitting and closure of TSDFs; for regulations promulgated pursuant to the Hazardous and Solid Waste Amendments (HSWA), such as land disposal restrictions; and for other programs, such as delisting of hazardous wastes. If a site is located in a state with an authorized RCRA program, the state's promulgated RCRA requirements will replace the equivalent federal requirements as potential ARARs.

An authorized state program may also be more stringent than the federal program. For example, a state may have more stringent test methods for characteristic wastes, or may list more wastes as hazardous than the federal program does. Therefore, it is important to determine whether laws in an authorized state go beyond the federal regulations.

#### **Closure**

For each type of unit regulated under RCRA, Subtitle C regulations contain standards that must be met when a unit is closed. For treatment and storage units, closure standards require that all hazardous waste and hazardous waste residues be removed. In addition to removal, closure by removal, called *clean closure*, such as landfills, surface impoundments, and waste treatment units, may be closed as disposal or landfill units with waste in place, referred to as *landfill closure*. Frequently, RCRA closure requirements for such land-based units will be either applicable or relevant and appropriate at Superfund sites.

#### **Applicability of Closure Requirements**

The basic prerequisites for applicability of closure requirements are (1) the waste must be hazardous and (2) the unit (or AOC) must have received waste. The RCRA requirements became effective, either because of the original date of disposal or because of the date of the CERCLA action constituting disposal. When RCRA closure requirements are applicable, the regulations allow only two types of closure:

- **Clean Closure.** All waste residues and containment system components (e.g., lined containers, contaminated subsoils, and structures and equipment) must be removed and the waste must be managed as hazardous waste or disposed of before the site management is completed (see 40 CFR 264.111, 264.228(a)).

- **Landfill Closure.** The unit must be capped with a final cover designed and constructed to:
  - Provide long-term minimization of migration of liquids.
  - Function with minimum maintenance.
  - Promote drainage and minimize erosion.
  - Accommodate settling and subsidence.
  - Have a hydraulic conductivity less than or equal to any bottom liner system or natural subsoils present.

Clean closure standards assume the site will have unrestricted use and require no maintenance after the closure has been completed. These standards are often referred to as the "eatable solid, drinkable leachate" standards. In contrast, disposal or landfill closure standards require postclosure care and maintenance of the unit for at least 30 years after closure. Postclosure care includes maintenance of the final cover, operation of a leachate and removal system, and maintenance of a ground-water monitoring system [see 40 CFR 264.117, 264.228(b)].

EPA has prepared several guidance documents on closure and final covers (1, 3). These guidance documents are not ARARs, but are to be considered for CERCLA actions and may assist in complying with these regulations. The performance standards in the regulation may be attained in ways other than those described in guidance, depending on the specific circumstances of the site.

#### **Relevant and Appropriate Closure Requirements**

If they are not applicable, RCRA closure requirements may be determined to be relevant and appropriate. There is more flexibility in designing closure for relevant and appropriate requirements because the Agency has the flexibility to determine which requirements in the closure standards are relevant and appropriate. Under this scenario, a hybrid closure is possible. Depending on the site circumstances and the remedy selected, clean closure, landfill closure, or a combination of requirements from each type of closure may be used.

The proposed revisions to the NCP discuss the concept of hybrid closure (53 FR 51446). The NCP illustrated the following possible hybrid closure approaches:

- **Hybrid-Clean Closure.** Used when leachate will not impact the ground water (even though residual contamination and leachate are above health-based levels) and contamination does not pose a direct contact threat. With hybrid-clean closure:
  - No covers or long-term management are required.
  - Fate and transport modeling and model verification are used to ensure that ground water is usable.
  - A property deed notice is used to indicate the presence of hazardous substances.
- **Hybrid-Landfill Closure.** Used when residual contamination poses a direct contact threat, but does not pose a ground-water threat. With hybrid-landfill closure:
  - Covers, which may be permeable, are used to address the direct contact threat.
  - Limited long-term management includes site and cover maintenance and minimal ground-water monitoring.
  - Institutional controls (e.g., land-use restrictions or deed notices) are used as necessary.

The two hybrid closure alternatives are constructs of applicable laws but are not themselves promulgated at this time. These alternatives are possible when RCRA requirements are relevant and appropriate, but not when closure requirements are applicable.

#### **REFERENCES**

1. U.S. EPA. 1989. Final covers on hazardous waste landfills and surface impoundments. Office of Solid Waste and Emergency Response Technical Guidance Document EPA 530-SW-89-047, Risk Reduction Engineering Laboratory, Cincinnati, OH.
2. U.S. EPA. 1989. RCRA ARARs: focus on closure requirements. Office of Solid Waste and Emergency Response Directive 9234.2-04FS, Office of Solid Waste and Emergency Response, Washington, DC.
3. U.S. EPA. 1978. Closure and postclosure standards. Draft RCRA Guidance Manual for Subpart G. EPA 530-SW-78-010. Office of Solid Waste and Emergency Response, Washington, DC.

---

## CHAPTER 2

### SOILS USED IN COVER SYSTEMS

#### INTRODUCTION

This chapter describes several important aspects of soils design for cover systems over waste disposal units and site remediation projects. The chapter focuses on three critical components of the cover system: composite action of soil with a geomembrane liner; design and construction of low hydraulic conductivity layers of compacted soil; and mechanisms by which low hydraulic conductivity layers can be damaged. In addition, types of soils used for liquid drainage or gas collection also will be discussed.

#### TYPICAL COVER SYSTEMS

Cover systems perform many functions. One of the principal objectives of a cover system is to reduce leaching of contaminants from buried wastes or contaminated soils by minimizing water infiltration. Cover systems also promote good surface drainage and maximize runoff. In addition, they restrict or control gas migration, or, at some sites, enhance gas recovery. Finally, cover systems provide a physical separation between buried wastes or contaminated materials and animals and plant roots. When designing a cover system, all of these requirements, plus others, typically must be considered.

As presented and discussed in Chapter 1, Figures 1-1 and 1-2 illustrate two typical cover profiles (see pages 1-3 and 1-7). Figure 1-1 illustrates the minimum cover profile recommended by EPA for hazardous waste. Many of the layers shown in the figure are composed of soils or have soil components. Each layer has a different purpose and the materials must be selected and the layer designed to perform the intended function:

- *Topsoil* - The topsoil supports vegetation (which minimizes erosion and maximizes evapotranspiration), separates the waste from the surface, stores water that infiltrates the cover system, and protects underlying materials from freezing during winter and from desiccation during dry periods.
- *Filter* - The filter separates the underlying drainage material from the topsoil so that the topsoil will not plug the drainage material. The filter is often a geotextile, but also can be soil.

- *Drainage Layer* - The drainage layer (which is not needed in arid climates) serves to drain away water that infiltrates the topsoil.
- *Geomembrane Liner and Low Hydraulic Conductivity Soil Layer* - The geomembrane and low hydraulic conductivity soil layer form a composite liner that serves as a hydraulic barrier to impede water infiltration through the cover system.

Figure 1-2 illustrates an alternative cover profile recommended by EPA for hazardous waste. In Figure 1-2, *cobbles* are placed on the topsoil to provide protection from erosion. Cobbles, which are normally used only at very arid sites, allow precipitation to infiltrate underlying materials, but do not promote evapotranspiration (since there are no plants present). Figure 1-2 also depicts a *biobarrier* between two filters. The biobarrier is usually a layer of cobbles, approximately 30- to 90-cm (1- to 3-ft) thick. The biobarrier stops animals from burrowing into the ground, and, if the cobbles are dry, prevents the penetration of plant roots. The *gas vent layer* facilitates removal of gases that could accumulate in the waste layer.

The cover profiles shown in Figures 1-1 and 1-2 provide general guidance only. Depending on the specific circumstances at a particular site, some of the layers shown in these figures may not be necessary. For example, at an extremely arid site, a cover system placed over non-hazardous, nonputrescible waste may simply consist of a single layer of topsoil with no drainage layer, no hydraulic barrier, and no gas vent layer. Conversely, some situations may require more layers than those shown in these figures. For example, radioactive waste such as uranium mill tailings may require a radon-emission-barrier layer. In addition, the designer may need to include several components or layers within the cover system to satisfy multiple objectives. When such objectives lead to conflicting technical requirements, tradeoffs are frequently necessary.

#### FLOW RATES THROUGH LINERS

Figure 2-1 illustrates three types of hydraulic barriers (liners) for cover systems: 1) a low hydraulic conduc-

tivity, compacted soil liner; 2) a geomembrane liner; and 3) a geomembrane/soil composite liner. Flow rates for each of these types of liners are calculated below for the purpose of comparing the effectiveness of the barriers. Flow rates through compacted soil liners are calculated using Darcy's law, the basic equation used to describe the flow of fluids through porous materials. Darcy's law states:

$$q = k_s i A$$

where  $q$  is the flow rate ( $m^3/s$ );  $k_s$  represents the hydraulic conductivity of the soil ( $m/s$ );  $i$  is the dimensionless hydraulic gradient; and  $A$  is the area ( $m^2$ ) over which flow occurs. If the soil is saturated and there is no soil suction, the hydraulic gradient ( $i$ ) is:

$$i = (h + D) / D$$

where the terms are defined in Figure 2-1 ( $h$  is the depth of liquid ponded above a liner with thickness  $D$ ). For example, if 30 cm (1 ft) of water is ponded on a 90-cm (3-ft) thick liner that has a hydraulic conductivity of  $1 \times 10^{-9}$  m/s ( $1 \times 10^{-7}$  cm/s), the flow rate is 120 gal (454 L)/acre/day. If the hydraulic conductivity is increased or decreased, the flow rate is changed proportionally (Table 2-1).

The second liner depicted in Figure 2-1 is a geomembrane liner. It is assumed that the geomembrane has one or more circular holes (defects) in the liner, that the holes are sufficiently widely spaced that leakage through each hole occurs independently from the other holes, that the head of liquid ponded above the liner ( $h$ ) is

**Table 2-1. Calculated Flow Rates through Soil Liners with 30 cm of Water Ponded on the Liner**

Hydraulic Conductivity (cm/s)	Rate of Flow (gal/acre/day) <sup>a</sup>
$1 \times 10^{-6}$	1,200
$1 \times 10^{-7}$	120
$1 \times 10^{-8}$	12
$1 \times 10^{-9}$	1

<sup>a</sup>L = gal x 3.785

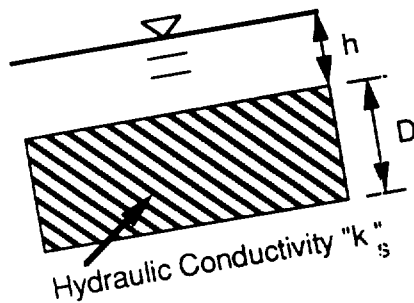

**SOIL LINER**

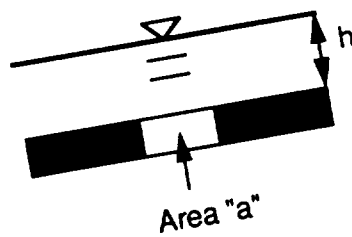

**GEOMEMBRANE**

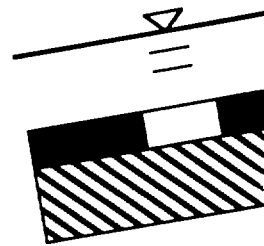

**COMPOSITE**

constant, and that the soil that underlies the geomembrane has a very large hydraulic conductivity (the subsoil offers no resistance to flow through a hole in the geomembrane). Giroud and Bonaparte (1) recommend the following equation for estimating flow rates through holes in geomembranes under these assumptions:

$$q = C_b a (2gh)^{0.5}$$

where  $q$  is the rate of flow ( $m^3/s$ );  $C_b$  is a flow coefficient with a value of approximately 0.6;  $a$  is the area ( $m^2$ ) of a circular hole;  $g$  is the acceleration due to gravity ( $9.81 m/s^2$ ); and  $h$  is the head (m) above the liner. For example, if there is a single hole with an area of  $1 cm^2$  ( $0.0001 m^2$ ) and the head is 30 cm (1 ft) (0.305 m), the calculated rate of flow is 3,300 gal (12,491 L)/day. If there is one hole per acre, then the flow rate is 3,300 gal (12,491 L)/acre/day.

Flow rates for other circumstances are calculated in Table 2-2. Giroud and Bonaparte report that with poor quality control, one hole per acre is typical (1). With good quality control, 30 holes per acre is typical. They also note that most defects are small ( $<0.1 cm^2$ ), but that larger holes are occasionally observed. In calculating the rate of flow for "No Holes" in Table 2-2, it was assumed that any flow of liquid was controlled by water vapor transmission

**Table 2-2. Calculated Flow Rates Through a Geomembrane with a Head of 30 cm of Water above the Geomembrane**

Size of Hole ( $cm^2$ )	Number of Holes Per Acre	Rate of Flow (gal/acre/day)
No holes	--	33
0.1	1	10.0
0.1	30	330
1	1	100
1	30	330
10	1	33

<sup>a</sup>L = gal x 3.785

Soil liner, geomembrane liner, and composite liner.

flux of 0.01 gal/acre/day corresponds to a typical water vapor transmission rate of geomembrane liner materials.

The third type of liner depicted in Figure 2-1 is a *composite liner*. Giroud and Bonaparte (2) and Giroud et al. (3) discuss seepage rates through composite liners. They recommend the following equation for computing seepage rates for cases in which the hydraulic seal between the geomembrane and soil is poor:

$$q = 1.15 h^{0.9} a^{0.1} k_s 0.74$$

where all the parameters and units are as indicated previously. This equation assumes that the hydraulic gradient through the soil is 1. If there is a good hydraulic seal between the geomembrane liner and underlying soil, the flow rate is approximately one-fifth the value computed from the equation shown above; the constant in the equation is 0.21 rather than 1.15 for the case of a good seal. For example, suppose the geomembrane component of a composite liner has one hole/acre with an area of 1 cm<sup>2</sup> per hole, the hydraulic conductivity of the subsoil is 1 x 10<sup>-7</sup> cm/s (1 x 10<sup>-9</sup> m/s), the head of water is 30 cm (1 ft) and a poor seal exists between the geomembrane and soil. The calculated flow rate is 0.8 gal (3 L)/acre/day. Table 2-3 shows other calculated flow rates for composite liners with a head of water of 30 cm (1 ft.)

It is useful to compare the three types of liners under a variety of assumed conditions, as illustrated in Table 2-4. For discussion purposes, each liner type is classified as poor, good, or excellent. EPA requires that low permeability compacted soil liners used for hazardous wastes have a hydraulic conductivity no greater than 1 x 10<sup>-7</sup> cm/s; therefore, a soil liner with a hydraulic conductivity of 1 x 10<sup>-7</sup> cm/s is described in Table 2-4 as a "good" liner. A compacted soil liner with a 10-fold higher hydraulic conductivity is described as a "poor" liner, and a soil liner with a 10-fold lower hydraulic conductivity is described as an "excellent" liner.

For geomembrane liners, a liner with a large number of small holes (30 holes/acre, with each hole having an area of 0.1 cm<sup>2</sup>) is described as a "poor" liner because Giroud and Bonaparte suggest that such a large number of defects would be expected only with minimal construction quality control (1). A "good" geomembrane liner was assumed to have been constructed with good quality assurance and an "excellent" geomembrane liner was assumed to have one small hole/acre (1). For all of the seepage rates computed for composite liners in Table 2-4, it was assumed that there was poor contact between the geomembrane and soil.

As Table 2-4 illustrates, a composite liner (even one built by poor to mediocre standards) significantly outperforms a soil liner or a geomembrane liner alone. For this reason, a composite liner is recommended when there is enough rainfall to warrant a very low-permeability hydraulic barrier in the cover system.

**Table 2-3. Calculated Flow Rates for Composite Liners with a Head of Water of 30 cm**

Hydraulic Conductivity of Subsoil (cm/s)	Size of Hole in Geomembrane (cm <sup>2</sup> )	Number of Holes/Acre	Rate of Flow (gal/acre/day) <sup>a</sup>
1 x 10 <sup>-6</sup>	0.1	1	3
1 x 10 <sup>-6</sup>	0.1	30	102
1 x 10 <sup>-6</sup>	1	1	4
1 x 10 <sup>-6</sup>	1	30	130
1 x 10 <sup>-6</sup>	10	1	5
1 x 10 <sup>-7</sup>	0.1	1	0.6
1 x 10 <sup>-7</sup>	0.1	30	19
1 x 10 <sup>-7</sup>	1	1	0.8
1 x 10 <sup>-7</sup>	1	30	24
1 x 10 <sup>-7</sup>	10	1	1.0
1 x 10 <sup>-8</sup>	0.1	1	0.1
1 x 10 <sup>-8</sup>	0.1	30	3
1 x 10 <sup>-8</sup>	1	1	0.1
1 x 10 <sup>-8</sup>	1	30	4
1 x 10 <sup>-8</sup>	10	1	0.2
1 x 10 <sup>-9</sup>	0.1	1	0.2
1 x 10 <sup>-9</sup>	0.1	30	0.6
1 x 10 <sup>-9</sup>	1	1	0.03
1 x 10 <sup>-9</sup>	1	30	0.8
1 x 10 <sup>-9</sup>	10	1	0.03

<sup>a</sup>L = gal x 3.785

To maximize the effectiveness of a composite liner, the geomembrane must be placed to achieve a good hydraulic seal with the underlying layer of low hydraulic conductivity soil. As shown in Figure 2-2, the composite liner works by limiting the flow of fluid in the soil to a very small area. Fluid must not be allowed to spread laterally along the interface between the geomembrane and soil. To ensure good hydraulic contact, the soil liner should be smooth-rolled with a steel-drummed roller before the geomembrane is placed, and the geomembrane should have a minimum number of wrinkles when it is finally covered. In addition, high-permeability material, such as a sand bedding layer or geotextile, should not be placed between the geomembrane and low hydraulic conductivity soil (Figure 2-2) because this will destroy the composite action of the two materials.

If there are concerns that rocks or stones in the soil material may punch holes in the geomembrane, the stones should be removed, or a stone-free material with a low hydraulic conductivity placed on the surface. Vibratory screens also can be used to sieve stones prior to placement. Alternatively, mechanical devices that sieve stones or move them to a row in a loose lift of soil may be used. A different material, or a differently

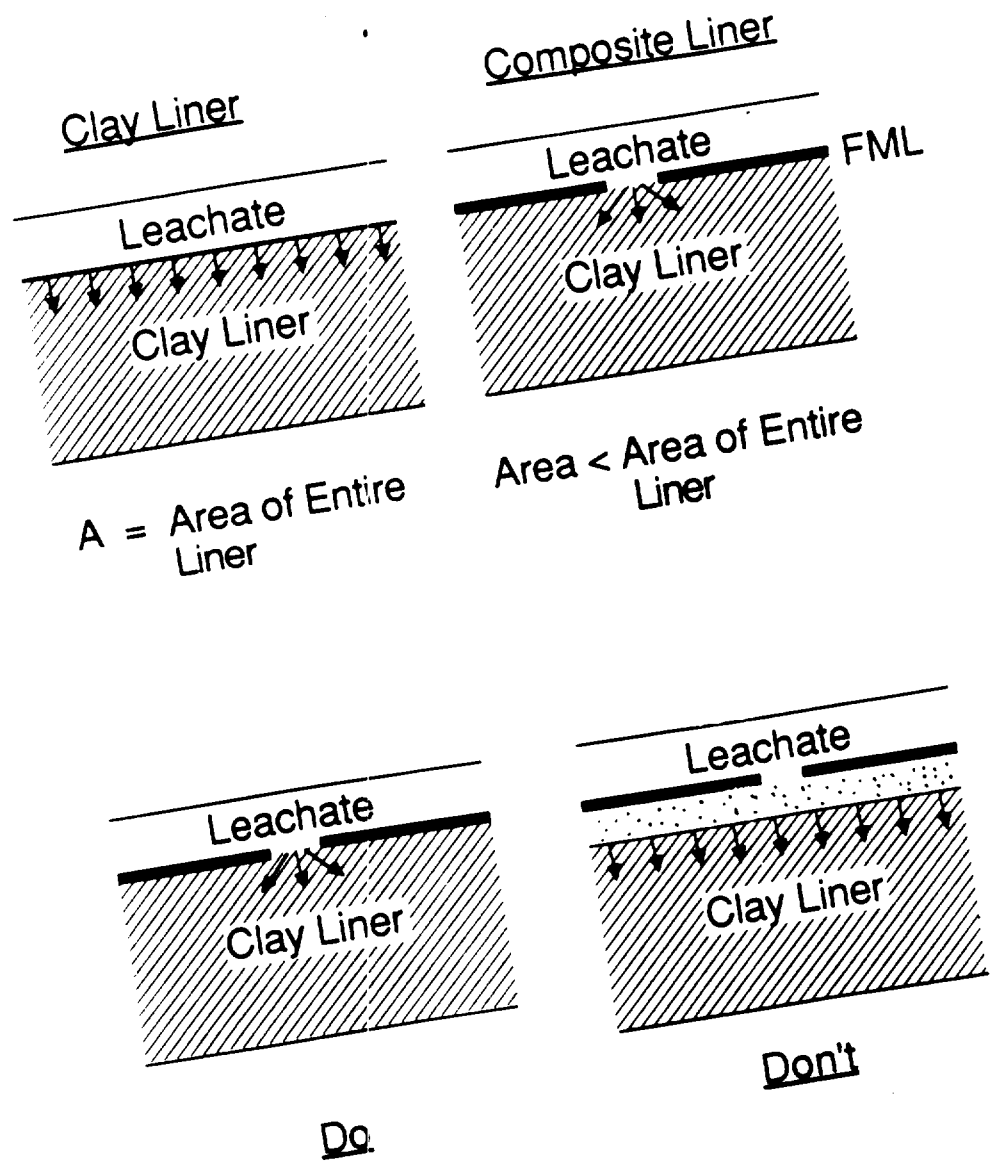

Figure 2-2. Soil liner and composite liner.

processed material that has fewer and smaller stones, may be used to construct the uppermost lift of the soil liner (i.e., the lift that will serve as a foundation for the geomembrane).

### CRITICAL PARAMETERS FOR SOIL LINERS

#### Materials

The primary requirement for a soil liner material is that it be capable of being compacted to produce a suitably low hydraulic conductivity. To meet this requirement, the following conditions should be met:

- **Fines** - The soil should contain at least 20 percent fines (fines are defined as the percentage, on a dry-

weight basis, of material passing the No. 20 sieve which has openings of 0.075 mm).

- **Plasticity Index** - The soil should have a plasticity index of at least 10 percent, although some soils with slightly lower plasticity index may be suitable. Soils with plasticity indices less than about 10 percent and very little clay and usually will not produce the necessary low hydraulic conductivity. Soils with plasticity indices greater than 30 to 40 percent are difficult to work with, as they form hard chunks when compacted in the field, which make them difficult to place. Such soils also tend to have a high shrink/swell potential and may not be suitable.

**Table 2-4. Calculated Flow Rates for Soil Liners, Geomembrane Liners, and Composite Liners**

Type of Liner	Overall Quality of Liner	Assumed Values of Key Parameters	Rate of Flow (gal/acre/day) <sup>a</sup>
Compacted Soil	Poor	$k_5=1 \times 10^{-6}$ cm/s	1,200
Geomembrane	Poor	30 holes/acre; $a=0.1$ cm <sup>2</sup>	10,000
Composite	Poor	$k_5=1 \times 10^{-6}$ cm/s 30 holes/acre; $a=0.1$ cm <sup>2</sup>	100
Compacted Soil	Good	$k_5=1 \times 10^{-7}$ cm/s	120
Geomembrane	Good	1 hole/acre; $a=1$ cm <sup>2</sup>	3,300
Composite	Good	$k_5=1 \times 10^{-7}$ cm/s 1 hole/acre; $a=1$ cm <sup>2</sup>	0.8
Compacted Soil	Excellent	$k_5=1 \times 10^{-8}$ cm/s	12
Geomembrane	Excellent	1 hole/acre; $a=0.1$ cm <sup>2</sup>	330
Composite	Excellent	$k_5=1 \times 10^{-8}$ cm/s 1 hole/acre; $a=0.1$ cm <sup>2</sup>	0.1

<sup>a</sup>L = gal x 3.785

reason. Soils with plasticity indices between approximately 10 and 35 percent are generally ideal.

- **Percentage of Gravel** - The percentage of gravel (defined as material retained on the No. 4 sieve, which has openings of 4.76 mm) must not be excessive. A maximum amount of 10 percent gravel is suggested as a conservative figure. For many soils, however, larger amounts may not necessarily be deleterious if the gravel is uniformly distributed in the soil and does not interfere with compaction by footed rollers. For example, Shakoor and Cook found that the hydraulic conductivity of a compacted, clayey soil was insensitive to the amount of gravel present, as long as the gravel content did not exceed 50 percent (4). Gravel is only deleterious if the pores between gravel particles are not filled with clayey soil and the gravel forms a continuous pathway through the liner. The key problem to be avoided is segregation of gravel in pockets that contain little or no fine-grained soil.

- **Stones and Rocks** - No stones or rocks larger than 2.5 to 5 cm (1 to 2 in.) in diameter should be present in the liner material.

If the soil material does not contain enough clay or other fine-grained minerals to be capable of being compacted to the desired low hydraulic conductivity, commercially produced clay minerals, such as sodium bentonite, may be mixed with the soil. Figure 2-3 shows the relationship between the percentage of bentonite added to a soil and the hydraulic conductivity after compaction for a well-graded, silty soil that was carefully mixed in the laboratory. The percentage of bentonite is defined as the dry weight of bentonite divided by the dry weight of soil to which the bentonite is added ( $W_b/W_s$ ). For well-graded soils containing a wide range of grain sizes, adding just a small amount of bentonite will usually lower the hydraulic conductivity of the soil to below  $1 \times 10^{-7}$ . For poorly graded soils, e.g., those with a uniform grain size, more bentonite is often needed.

Bentonite can be added to soil in two ways. One technique is to spread the soil to be amended over an area in a loose lift approximately 23 to 30 cm (9- to 12-in.) thick. Bentonite is then applied to the surface at a controlled rate and mixed into the soil using mechanical mixing equipment, such as a rototiller or road reclaimer (recycler). Multiple passes of the mixing equipment are usually recommended. The second procedure is to mix the ingredients in a pugmill, which is a large device used to mix bulk materials such as the ingredients that form Portland cement concrete. Bulk mixing in a pugmill usually provides more controlled mixing than combining ingredients in place in a loose lift of soil. However, mixing of bentonite into a loose lift of soil can be adequate if the mixing is done carefully with multiple passes of mechanical mixers and careful control over rates of application and depth of mixing. The reason why bulk mixing is usually recommended is that control over the mixing process is easier.

#### **Water Content**

The water content of the soil at the time it is compacted is an important variable controlling the engineering properties of soil liner materials. The lower half of Figure 2-4 shows a soil compaction curve. If soil samples are mixed at several water contents and then compacted with a consistent method and energy of compaction, the result is the relationship between dry unit weight and molding water content shown in the lower half of Figure 2-4. The molding water content at which the maximum dry unit weight is observed is termed the "optimum water content" and is indicated in Figure 2-4 with a dashed vertical line. Soils compacted at water contents less than optimum ("dry of optimum") tend to have a relatively high hydraulic conductivity whereas soils compacted at water contents greater than optimum ("wet of optimum") tend to have a low hydraulic conductivity. It is usually preferable to com-

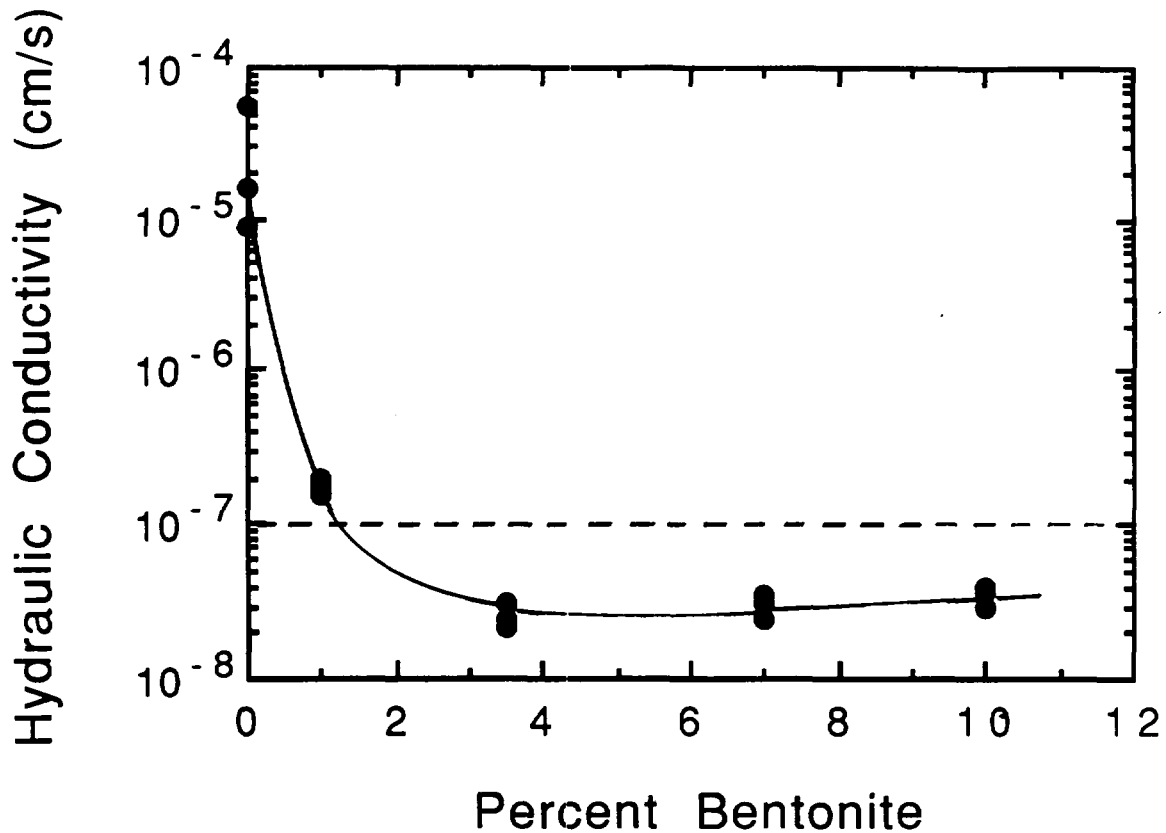

Figure 2-3. Effect of bentonite upon the hydraulic conductivity of a bentonite-amended soil.

$$\left(\text{Percent bentonite} = \frac{W_b}{W_s}\right)$$

compact the soil wet of optimum to achieve minimal hydraulic conductivity.

Figures 2-5 to 2-7 illustrate for a highly plastic soil why wet-of-optimum compaction is so effective in achieving low hydraulic conductivity. These three photographs show a soil that was compacted with standard Proctor energy (ASTM D698). The soil had a plasticity index of 41 percent. The optimum water content for this soil and compaction procedure was 19 percent. The specimen shown in Figure 2-5 was compacted at a water content of 12 percent (7 percent dry of optimum). This compacted soil had a very high hydraulic conductivity ( $1 \times 10^{-4}$  cm/s) because the dry, hard clods of soil were not broken down and remolded by the energy of compaction. The specimen shown in Figure 2-6 was compacted at a water content of 16 percent (3 percent dry of optimum) and had a hydraulic conductivity of  $1 \times 10^{-3}$  cm/s; the clods were still too dry and hard at this water content to permit the clods to be remolded into a homogeneous mass with low hydraulic conductivity. The specimen shown in Figure 2-7 was compacted at a water content of 20 percent (1 percent wet of optimum) and had a hydraulic conductivity of  $1 \times 10^{-9}$  cm/s. At this water content, the clods were wet, soft, and easily remolded into a homogeneous mass that was free of remnant clods and large inter-clod voids and pore spaces. The visual differences between specimens

compacted dry versus wet of optimum are usually not as obvious as they are in Figures 2-5 to 2-7 for soils of lower plasticity. However, even for low-plasticity clays, experience has almost always shown that the soil must be compacted wet of optimum water content to achieve minimum hydraulic conductivity.

The water content of the soil must be adjusted to the proper value prior to compaction and the water should be uniformly distributed in the soil. If the soil requires additional water, it can be added with a water truck; care should be taken to apply the water to the soil in a controlled, uniform manner, e.g., with a spray bar mounted on the rear of the trucks. Rototillers (Figure 2-8) are very effective for mixing wetted soil; these devices distribute the water uniformly among clods of material. Figure 2-9 depicts the teeth on the blades of a rototiller, which provide the mixing action. Mechanical mixing to mix water evenly into the soil is especially important for highly plastic soils that form large clods of soil.

#### Compactive Energy

Another important variable controlling the engineering properties of soil liner materials is the energy of compaction. As shown in Figure 2-10, increasing the energy of compaction increases the dry unit weight of the soil, decreases the optimum water content, and reduces

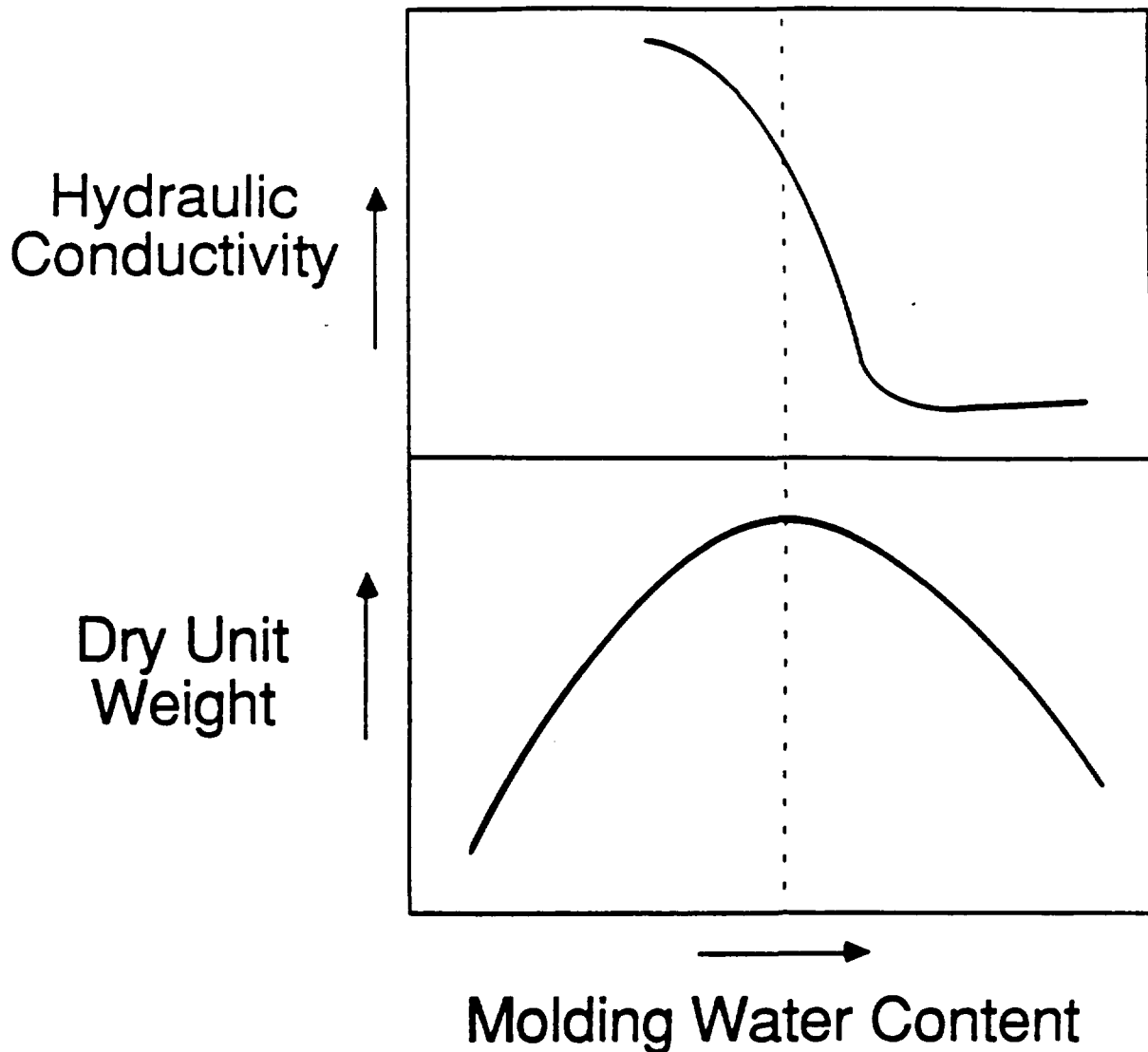

Figure 2-4. Hydraulic conductivity and dry unit weight versus molding water content.

hydraulic conductivity. The hydraulic conductivity of a soil that is compacted wet of optimum could be lowered by one to two orders of magnitude by increasing the energy of compaction, even though the dry unit weight of the soil is not increased measurably. More energy of compaction helps to remold clods of soil, realign soil particles, reduce the size or degree of connection of the largest pores in the soil, and lower hydraulic conductivity.

The compactive energy delivered to soil depends on the weight of the roller, the number of passes of the roller over a given area, and the thickness of the soil lift being compacted. Increasing the weight and number of passes, and decreasing the lift thickness, can increase the compactive effort. The best combination of these factors to use when compacting low hydraulic conductivity soil liners depends on the water content of the soil and the firmness of the subbase.

Heavy rollers cannot be used if the soil is very wet or if the foundation is weak and compressible (e.g., if municipal solid waste is located just 30- to 60-cm [1- to 2-ft] below the layer to be compacted). Rollers with static weights of at least 13,608 to 18,144 kg (30,000 to 40,000 pounds) are recommended for compacting low hydraulic conductivity layers in cover systems. Rollers that weigh up to 31,752 kg (70,000 pounds) are available and may be desirable for compacting bottom liners of landfills, but such rollers are too heavy for many cover systems because of the presence of compressible waste material a short distance below the cover.

The roller must make a sufficient number of passes over a given area to ensure adequate compaction. The minimum number of passes will vary, but at least 5 to 10 passes are usually required to deliver sufficient compactive energy and to provide adequate coverage.

Figure 2-6. Highly plastic soil compacted with standard Proctor procedures at a water content of 16%.

# STANDARD PROCTOR

16 %



Figure 2-5. Highly plastic soil compacted with standard Proctor procedures at a water content of 12%.

# STANDARD PROCTOR

12 %



Figure 2-7. Highly plastic soil compacted with standard Proctor procedures at a water content of 20%.

# STANDARD PROCTOR

20 %

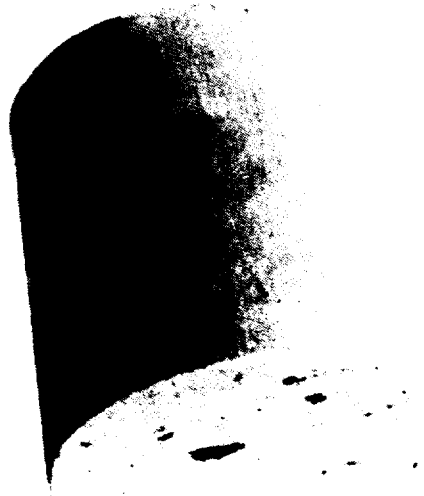

The clay-rich soils that are usually used to construct liners typically form dry, hard clods of soil or clods, depending on water content. Highly plastic soils always form large clods. Soils with low plasticity index less than about 10% do not remold into a homogeneous mass. For soils that form large clods, the clod pores if low hydraulic conductivity is achieved. Benson and Daniel described the influence of a highly plastic soil (plasticity index = 5). These investigations by breaking clods down to a clayey soil (4.76 mm or 0.2 in. then well No. 4 sieve). The soil was then compacted, and hydrated at least 24 hours. Results are Benson and Daniel's (1990) results are Table 2-5. The optimum water content for the clods processed through the sieve is 19 percent and 1.9-cm (3/4-in. in.) opening. Through the sieve, the soil compacted dry of optimum, the soil had a hydraulic conductivity that was magnitude lower than the soil with large soils were compacted wet of optimum had a negligible effect. Size is theref

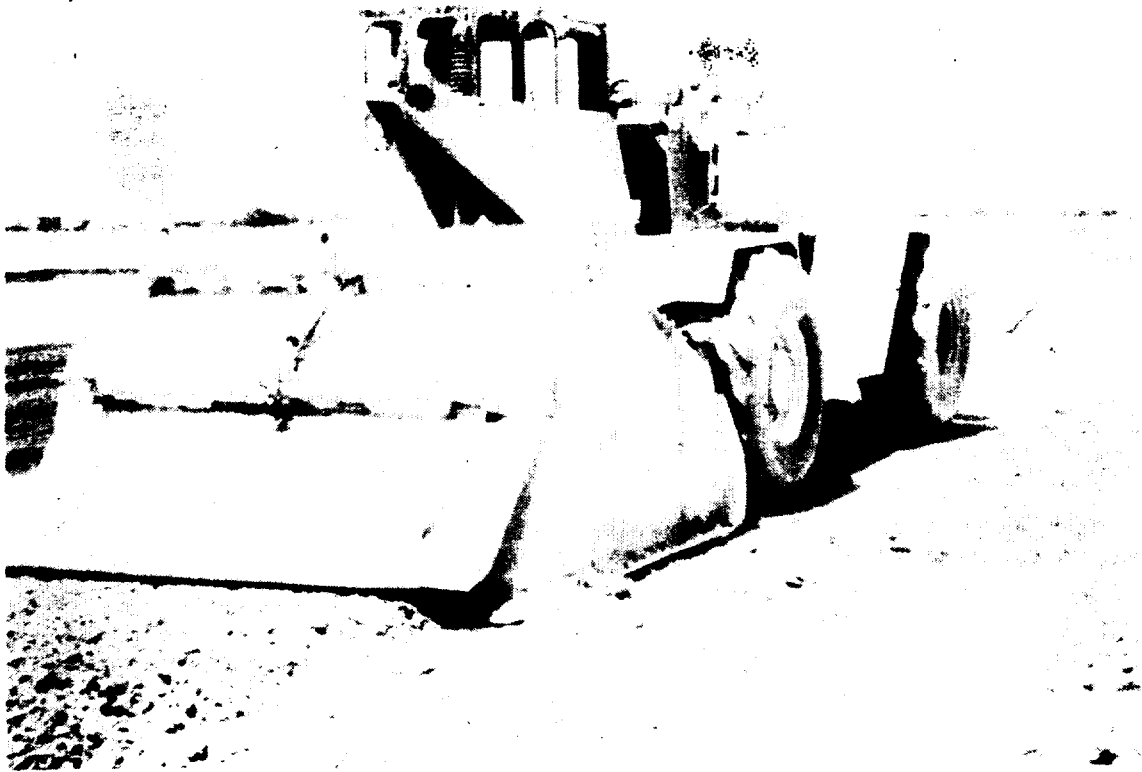

**Figure 2-8. Rototiller used to mix soil.**



**Figure 2-9. Blades and teeth on rototiller.**

**Table 2-5. Effect of Size of Clods during Processing of Soil upon Hydraulic Conductivity of Soil after Compaction**

Molding Water Content (%)	Hydraulic Conductivity (cm/s)	
	0.2-in. Clods <sup>a</sup>	0.75-in. Clods <sup>a</sup>
12	$2 \times 10^{-8}$	$4 \times 10^{-4}$
16	$2 \times 10^{-9}$	$1 \times 10^{-3}$
18	$1 \times 10^{-8}$	$8 \times 10^{-10}$
20	$2 \times 10^{-9}$	$7 \times 10^{-10}$

<sup>a</sup>cm = in. x 2.540

hard clods (dry of optimum), but not for wet, soft clods (wet of optimum). When the soil is compacted wet of optimum, the clods are sufficiently soft that they are easily remolded regardless of their original size.

One way to reduce the size of clods in dry materials is to use a road reclaimer (also called a road recycler), such as the one shown in Figure 2-11. This device pulverizes materials with teeth that rotate on a drum at a high speed. The device was used with great effectiveness at a site in Pennsylvania in which a mudstone was used for a liner material (Figure 2-12). In the figure, the road reclaimer has made a pass through a loose lift of material. After just one pass of the road reclaimer, the size of mudstone clods has been greatly reduced.

### **Bonding of Lifts**

Bonding of lifts is important in achieving a low hydraulic conductivity in soil liners. The upper half of Figure 2-13 illustrates a cross-section of a soil liner consisting of four lifts. A borehole has been drilled into the lowest lift, filled with a dye-stained fluid, left for a period of time, and then drained. The dye penetrates the soil further along lift interfaces than through the lifts themselves. Due to imperfect bonding of lifts, a zone of higher horizontal hydraulic conductivity exists at lift interfaces in this example.

Lift interfaces have important ramifications with respect to the overall hydraulic performance of a soil liner. The lower half of Figure 2-13 depicts a liner consisting of six lifts. Each lift has a few "hydraulic defects." If the lift interfaces have high hydraulic conductivity, water can flow downward through the more permeable zones in a lift and spread laterally along a lift interface until it encounters a permeable zone in the underlying lift. This process repeats for underlying lifts and lift interfaces. In this way lift interfaces provide hydraulic connection between defects in overlying and underlying lifts. Better overall performance (lower hydraulic conductivity) is achieved if lifts are bonded together to eliminate high conductivity at lift interfaces.

To bond lifts together, the surface of the previously compacted lift should be rough so that the newly placed lift can effectively blend into the surface. If necessary, the surface of the previously compacted lift can be roughened by discing the soil to a depth of approximately 2.5 cm (1 in). Discing the soil involves plowing up the soil surface to a shallow depth so that the surface is rough and so that there will be no abrupt interface between lifts.

Compactors with long "feet" on the drums are useful in blending one lift into another. Figure 2-14 shows a popular heavy compactor (20,000 kg [44,000 pounds]) with feet that are 18 to 23 cm (7 to 9 in.) long. During the first few passes of the compactor, the feet sink through a loose lift of soil and compact the newly placed lift into the surface of the previously compacted lift. Using a roller with feet that fully penetrate a loose lift of soil is recommended to bond lifts and to minimize high horizontal hydraulic conductivity at lift interfaces.

If a geomembrane liner will be placed on the compacted soil liner, the final surface of the soil liner should be compacted with a smooth, steel drum roller to achieve a good hydraulic seal.

### **EFFECTS OF DESICCATION**

Desiccation of soil liners occurs whenever the soil liner dries, which can be during or after construction. Desiccation causes soil liner materials to shrink and, potentially, to crack. Cracking can be disastrous in terms of hydraulic conductivity because cracked liners are more permeable than uncracked liners.

Boynton and Daniel desiccated slabs of compacted clay, trimmed cylindrical test specimens for hydraulic conductivity testing from the desiccated slabs, and measured the hydraulic conductivity at different effective confining stresses (6). In laboratory tests, the confining stress simulates the weight of overburden soil; the greater the confining stress, the greater the depth of burial below the surface that is simulated. Control tests also were performed on soils that had not been desiccated. These results are summarized in Figure 2-15. At low confining stress, the desiccated soils were much more permeable than the control. At high confining stress, however, the desiccated soils were no more permeable than the control. It appeared that the application of a large compressive stress (>5 psi, or 35 kPa) closed the desiccation cracks that had formed and, in combination with hydration of the soil, essentially fully healed the damage done by desiccation.

In cover systems, the overburden stress on the liner components is controlled by the depth of soil overlying the liner. Because the thickness of soil overburden above the liner seldom exceeds a few feet, the overburden stress is normally low. Soil applies an overburden stress of approximately 1 psi per foot of depth. Thus, for example, if

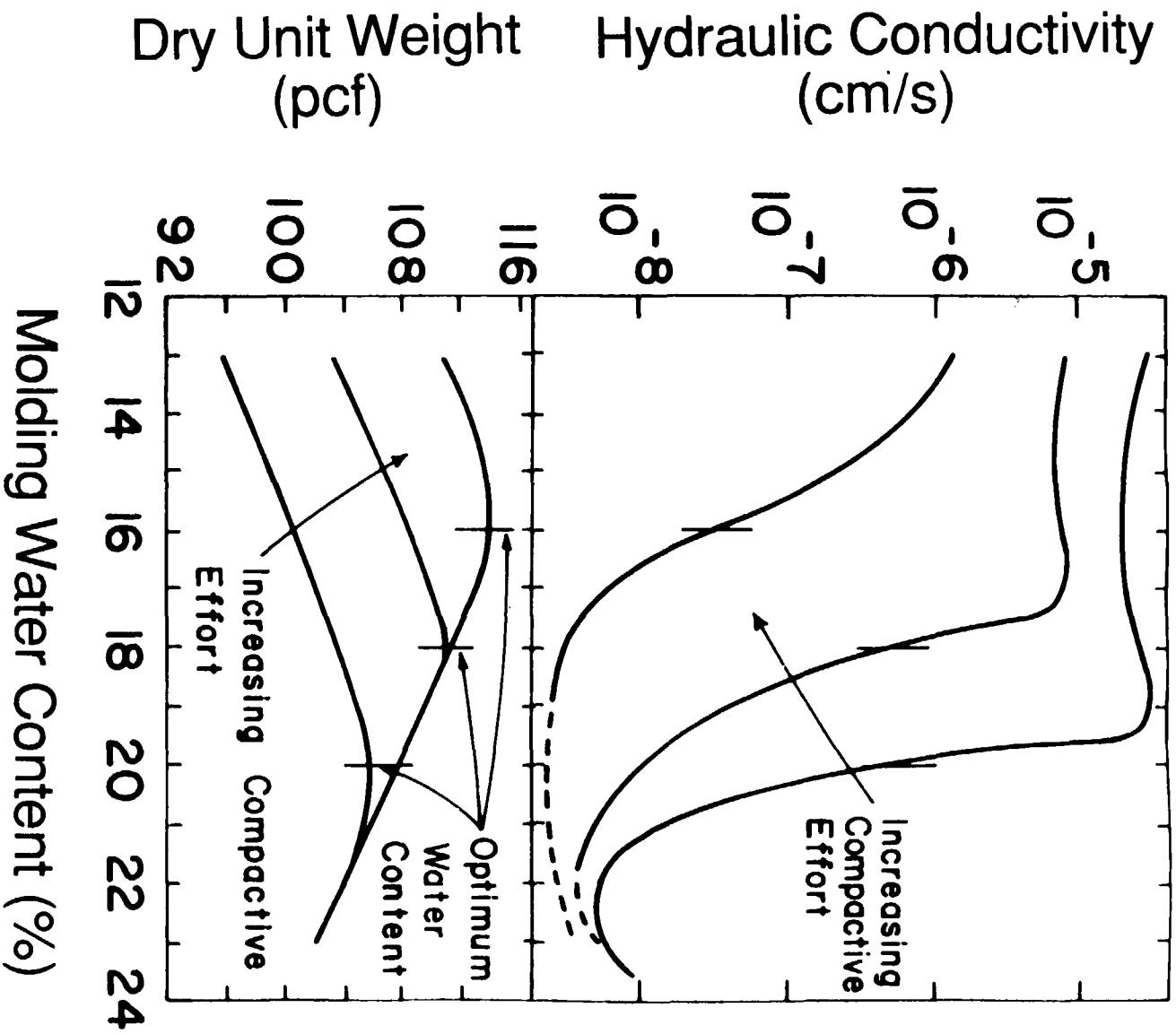

Figure 2-10. Influence of compactive effort upon hydraulic conductivity and dry unit weight.

60 cm (2 ft) of topsoil overlie a 60-cm (2-ft) thick layer of compacted clay, the maximum overburden stress at the bottom of the clay is approximately 4 psi. Based on Boynton and Daniel's results, if desiccation of the compacted soil liner occurs in a cover system, even though wetting of the soil may partly swell the soil and "heal" desiccation cracks, it is not expected that all the damage done by desiccation would be self-healing.

Montgomery and Parsons described an example of the damaging effects of desiccation (7). Test plots were built at the Omega Hills Landfill near Milwaukee, Wisconsin, in 1985. In both test plots, the cover systems consisted of

122 cm (4 ft) of compacted clay. The clay was overlain by 15 cm (6 in.) of topsoil in one plot and 46 cm (18 in.) of topsoil in the other. In both test plots, the upper 20 to 25 cm (8 to 10 in.) of compacted clay had weathered and become blocky after 3 years. Cracks up to 1.3-cm (1/2-in.) wide extended 89 to 102 cm (35 to 40 in.) into the compacted clay liner. The 46 cm (18 in.) of topsoil did not appear to be any more effective than 15 cm (6 in.) in protecting the underlying clay from desiccation.

The layer of low hydraulic conductivity, compacted soil placed in a cover system must be protected from the damaging effects of desiccation both during and after



Figure 2-11. Road recycler used to pulverize clods of soil.

construction. During construction, the soil must not be allowed to dry significantly either during or after compaction of each lift. Frequent watering of the soil is usually the best way to prevent desiccation during construction. The higher the water content of the soil and the higher the plasticity of the soil, the greater is the shrinkage potential from desiccation. There are two ways to provide the required protection after construction. One way is to bury the liner beneath an adequate depth of soil overburden; another technique is to place a geomembrane over the soil. If a geomembrane liner is placed on a soil liner to form a composite, it is often convenient to overbuild the soil liner (i.e., make it thicker than necessary) and then to scrape away a few inches of potentially desiccated surficial soil just before the geomembrane is placed.

#### EFFECTS OF FROST ACTION

Zimmie and La Plante studied the effects of freezing and thawing upon the hydraulic conductivity of a compacted clay by testing soils compacted dry of optimum, at optimum, and wet of optimum (8). They found that freeze/thaw cycles caused an increase in hydraulic conductivity of one to two orders of magnitude in all soils examined. Most of the damage was done after only one to two cycles of freezing and thawing. From this and other work, it is recommended that the low hydraulic conductivity component of cover systems not be allowed to freeze. Freezing can be avoided by burying the low

hydraulic conductivity soil layer under an adequately thick layer of soil.

#### EFFECTS OF SETTLEMENT

Two types of settlement are of concern with respect to covers: total settlement and differential settlement. Total settlement of the surface of a cover is the total downward movement of a fixed point on the surface. Differential settlement is always measured between two points and is defined as the difference between the total settlements at these two points. *Distortion* is defined as the differential settlement between two points divided by the distance along the ground surface between the two points. Excessive differential settlement of underlying waste can damage a cover system. If differential settlement occurs, tensile strains develop in cover materials as a result of bending stresses and/or elongation. Tensile strain is defined as the amount of stretching of an element divided by the original length of the element. Anytime the cover settles differentially, some part of the cover will be subjected to tension and will undergo tensile strain. Tensile strains are of concern because the larger the stretching (tensile strain), the greater the possibility that the soil will crack and that a geomembrane will rupture. *Bending stresses*, stresses that occur when an object is bent, result when covers settle differentially; part of the bent cover is in tension and part is in compression. Bending stresses are of concern because the tensile stresses associated with bending may be large enough to cause the



Figure 2-12. Passage of road recycler over loose lift of mudstone to reduce size of chunks of mudstone.

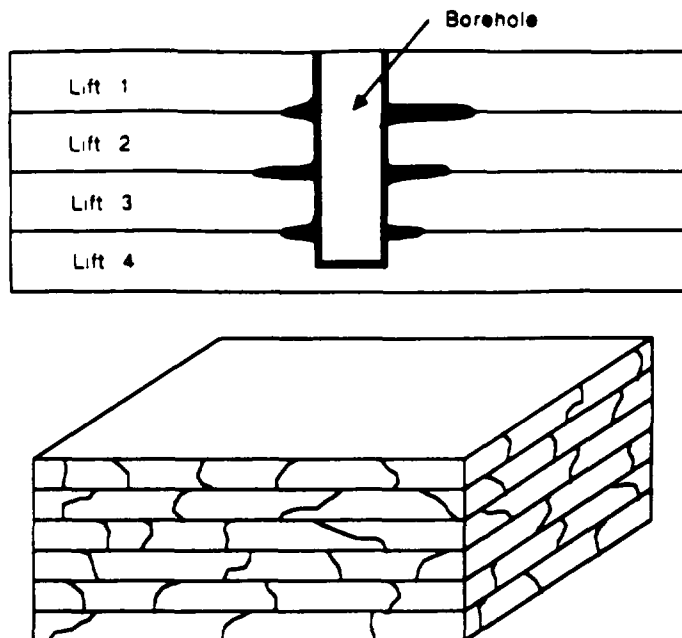

Figure 2-13. Effect of imperfect bonding of lifts on hydraulic performance of soil liner.



Figure 2-14. Example of heavy footed roller with long feet.

soil to crack. Geomembranes can generally withstand far larger tensile strains without failing than soils. The geomembrane also has the ability to elongate (stretch) a great deal without rupturing or breaking.

Gilbert and Murphy discuss the prediction and mitigation of subsidence damage to covers (9). Gilbert and Murphy developed a relationship between tensile strain in a cover and distortion,  $\delta/L$ , where  $\delta$  is the amount of differential settlement that occurs between two points that are a distance ( $L$ ) apart. This relationship is shown in Figure 2-16. As the distortion increases, the tensile strain in the cover soils increases.

Minor cracking of topsoil or drainage layers as a result of tensile stresses is of little concern. However, cracking of a hydraulic barrier, such as a layer of low hydraulic conductivity soil, is of great concern because the hydraulic integrity of the barrier layer is compromised if it is cracked. The amount of strain that a low hydraulic conductivity, compacted soil can withstand prior to cracking depends significantly upon the water content of the soil. As shown in Figure 2-17, soils compacted wet of optimum are more ductile than soils compacted dry of optimum. For cover systems, ductile soils that can withstand significant strain without cracking are preferred. For this reason, as well as the hydraulic conductivity considerations discussed earlier, it is preferable to compact low hydraulic conductivity soil layers wet of optimum. The soil must then be kept from drying out and cracking, as discussed earlier.

Gilbert and Murphy summarize information concerning tensile strain at failure for compacted, clayey soils. The available data show that such soils can withstand maximum tensile strains of 0.1 to 1 percent. If the limit (0.1 percent) is used for design, the maximum allowable value of distortion ( $\delta/L$ ) is approximately (Figure 2-17).

To put this in perspective, suppose that a circular depression develops in a cover system. The depression has a radius of 3 m (10 ft) (diameter=6 m [20 ft]). The maximum allowable  $\delta/L$  is 0.05, and  $L$  is the radius of the depression, which is 3 m (10 ft). The maximum settlement ( $\delta$ ) is 0.05 times 3 m (10 ft), or 0.15 m (6 in.). If the settlement at the center of the depression exceeds 6 in., the clay layer may crack from the strains caused by the settlement.

Some wastes (such as loose municipal solid waste) are not consolidated sludge of varying thickness) are compressible that constructing a cover system over the waste will almost certainly produce distortions larger than 0.05. The hydraulic integrity of a low hydraulic conductivity layer of compacted soil is seriously damaged by the distortion caused by differential settlement. If the waste is continuing to decompose, it may be necessary to place a temporary cover on the waste and allow it to take place prior to constructing a permanent system. Alternatives for stabilizing the

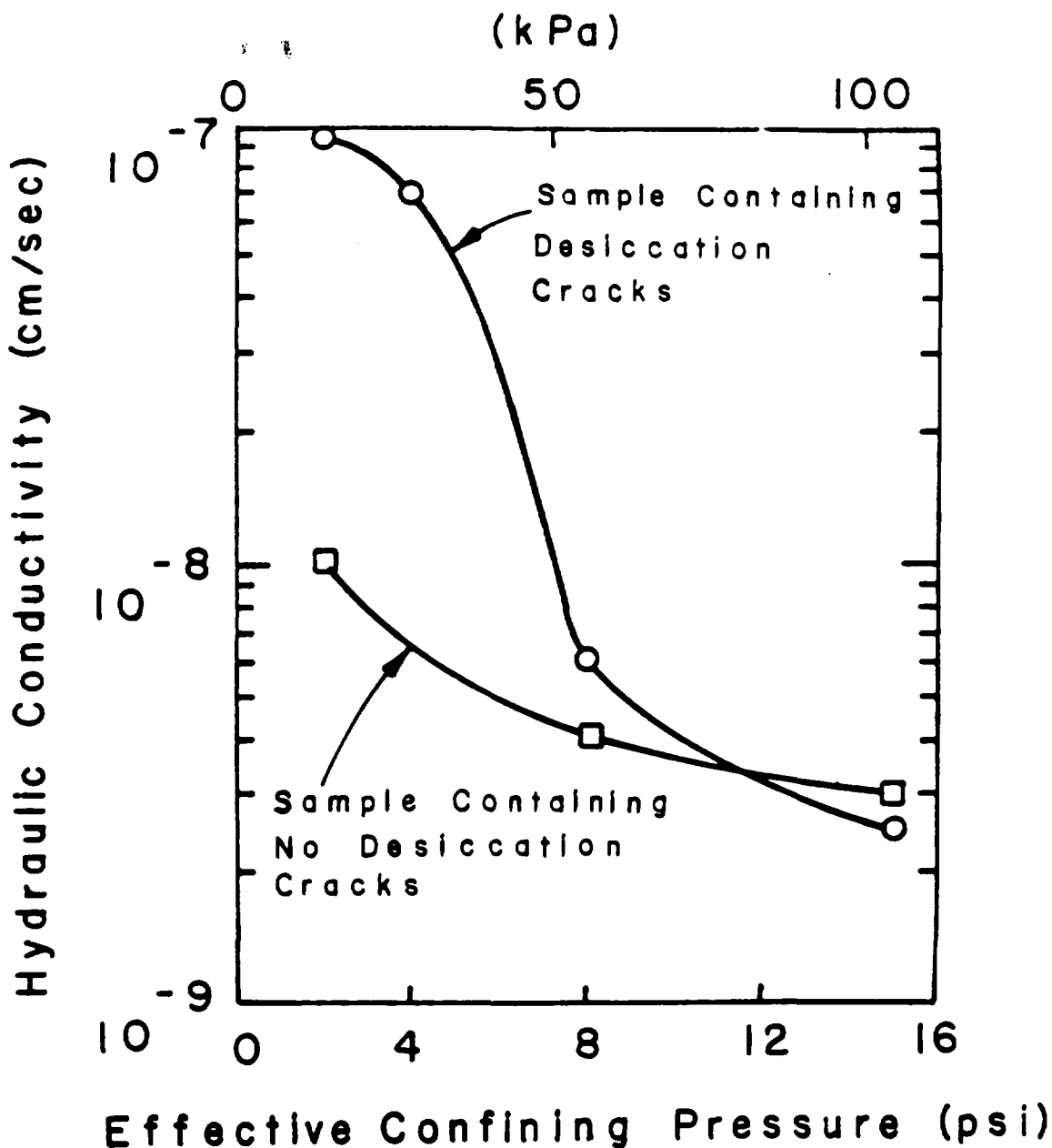

Figure 2-15. Effect of desiccation upon the hydraulic conductivity of compacted clay (6).

deep dynamic compaction, soil preloading, and the use of wick drains to consolidate sludges. These technologies for waste stabilization are presently emerging and appropriate descriptions are not available in the literature.

#### INTERFACIAL SHEAR

The stability of a cover system is controlled by the slope angle and the friction angles between the various interfaces of the cover system components. One potential problem with covers installed with a sloping surface is the risk that all or part of the cover system may slide downhill. The recent failure of a partly completed hazard-

ous waste landfill provides an example of the problem (10). At this facility, slippage occurred between two components of the liner system in the landfill cell. The cell was filled such that a slope was created on the liner system that caused slippage.

The interfacial shearing characteristics of all components of a cover system, as well as internal shearing parameters of all soil layers, must be known in order to evaluate stability. If the soils are fully saturated and below the free water surface, e.g., during a heavy rainstorm, the stability is much less than if the soils are dry. Thus, one must consider both typical and worst-case

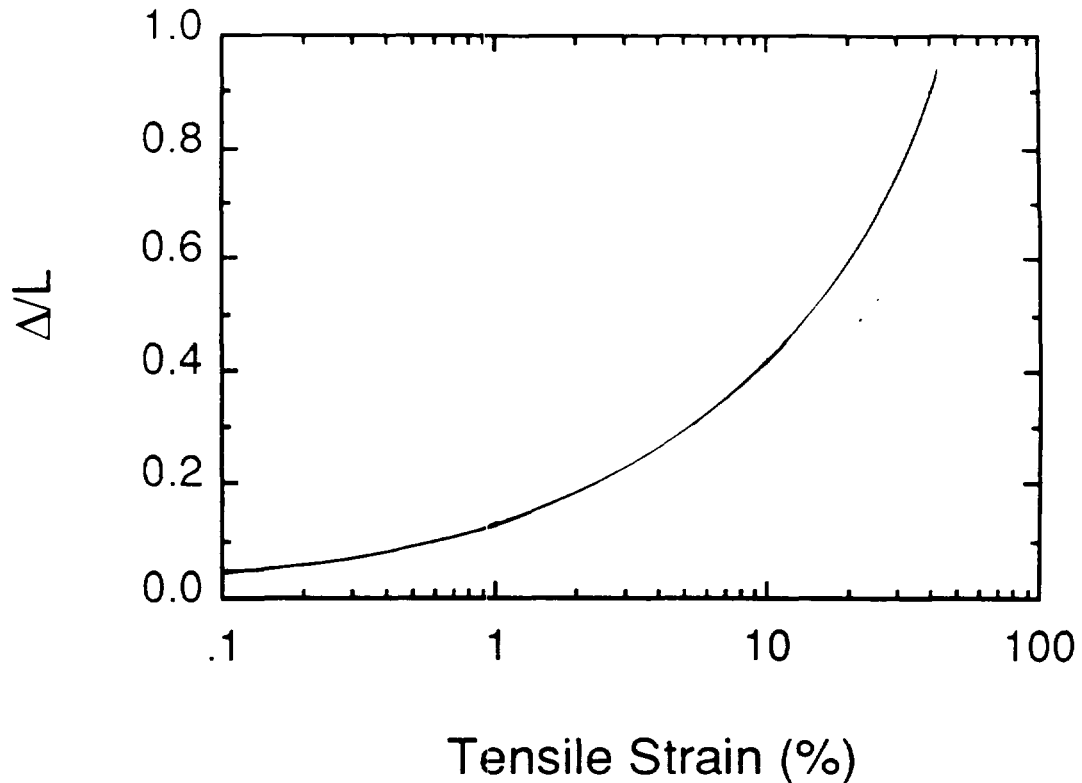

Figure 2-16. Relationship between distortion and tensile strain (9).

conditions when analyzing the stability of the cover system.

Methods of measuring interfacial friction between geosynthetic/geosynthetic or geosynthetic/soil interfaces are reviewed in detail by Takasumi et al. (11). No standard testing method exists, although one is under development by ASTM.

Seed and Boulanger (12) measured interfacial friction angles between a smooth high density polyethylene (HDPE) geomembrane and a compacted soil-bentonite mixture that contained 5 percent bentonite by dry weight. Interfacial friction angles were found to be very sensitive to compaction water content, dry unit weight, and the degree of wetting of the soil. For a given dry unit weight, increasing the molding water content or wetting the compacted soil reduced the interfacial friction angle. Increasing the density typically reduced the interfacial friction angle, as well. Unfortunately, the compaction conditions that would yield minimal hydraulic conductivity (i.e., compaction wet of optimum with a high energy of compaction) also yielded the lowest interfacial friction angles. Seed and Boulanger reported interfacial friction angles that were typically 5 to 10 degrees for the water content—unit weight combinations that would typically be employed to achieve minimal hydraulic conductivity.

The study of interfacial friction problems is an area of active research. At the present time, designers are cau-

tioned to give careful consideration to the problem and to measure friction angles along all potential sliding surfaces using the proposed construction materials for testing. If adequate stability is not provided, the designer will need to consider alternative materials (e.g., rougher geomembranes with higher interfacial friction angles), flatter slopes, or reinforcement of the cover, e.g., with geogrids.

### DRAINAGE LAYERS

Drainage layers are high-permeability materials used to drain fluids (such as infiltrating water) or gas produced from the waste. A drainage layer installed to drain infiltrating water is called a surface water collection and removal system. The hydraulic conductivity required for this layer depends upon the rate of infiltration, the slope of the layer, and the hydraulic conductivity of the underlying barrier layer. However, the efficiency of the drainage layer improves as the hydraulic conductivity of the drainage material increases. Thus, high hydraulic conductivity is a requirement for drainage layers.

The single most important factor controlling the hydraulic conductivity of sands and gravels is the amount of fine-grained material present. Geotechnical engineers define fine-grained materials as those materials that will pass through the openings of a No. 200 sieve (0.075 mm openings). A relatively small shift in the amount of fines

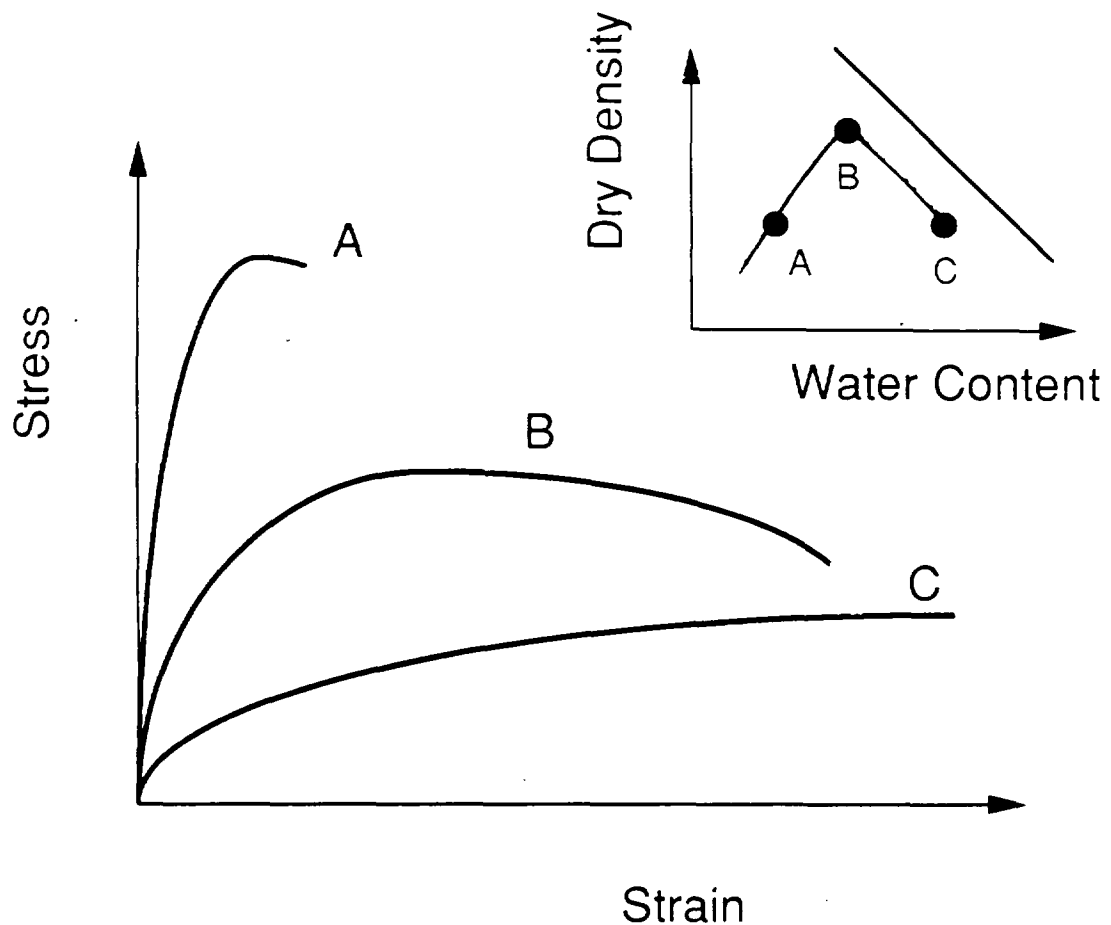

Figure 2-17. Relationship between shearing characteristics of compacted soils and conditions of compaction.

present in the soil can change the hydraulic conductivity by several orders of magnitude. The drainage material should be relatively free of fines if the material is to have a high hydraulic conductivity.

A minimal amount of compaction of the drainage materials in a cover is adequate to guard against settlement; excessive compaction is usually not necessary. In fact, excessive compaction may grind up soil particles, which would tend to lower the hydraulic conductivity of the drainage layer. However, sands may bulk if placed in a damp or wet condition, which can lead to an unacceptably loose material. If significant seismic ground shaking is possible at a site, compaction of drainage layers may be needed to minimize the risk of liquefaction-induced sliding.

Designers often place a highly permeable layer at the base of a cover system above gas-producing wastes, such as municipal solid waste. This layer aids in collecting gas and is called a gas collection layer. Adequate filters above and below the gas collection layer must be provided so that the collection layer does not become clogged with fine material. Vent pipes are normally

placed in the gas collection layer at a frequency of approximately one per acre.

#### SUMMARY

Soils are used in cover systems to support growth of vegetation, to separate buried wastes or contaminated soils from the surface, to minimize the infiltration of water, and to aid in collecting and removing gases. The most challenging aspect of utilizing soils in cover systems is designing, constructing, and maintaining a barrier layer of low hydraulic conductivity. Soils can be compacted to achieve a low initial hydraulic conductivity, but the soils can be damaged by excessive differential settlement, desiccation, and other environmental stresses. Protecting a compacted soil liner from damage is therefore the greatest challenge to the designer.

#### REFERENCES

1. Giroud, J.P. and R. Bonaparte. 1989a. Leakage through liners constructed with geomembranes—Part I. Geomembrane liners. Geotextiles and Geomembranes. Vol. 8: 27-67.

2. Giroud, J.P. and R. Bonaparte. 1989b. Leakage through liners constructed with geomembranes—Part II. Composite liners. *Geotextiles and Geomembranes*. Vol. 8: 71-111.
3. Giroud, J.P., A. Khatami, and K. Badu-Tweneboah. 1989. Evaluation of the rate of leakage through composite liners. *Geotextiles and Geomembranes*. Vol. 8: 337-340.
4. Shakoor, A. and B.D. Cook. 1990. The effect of stone content, size, and shape on the engineering properties of a compacted silty clay. *Bulletin of the Association of Engineering Geologists*. Vol. 27, No. 2: 245-253.
5. Benson, C.H. and D.E. Daniel. 1990. Influence of clods on hydraulic conductivity of compacted clay. *Journal of Geotechnical Engineering*. Vol. 116, No. 8: 1231-1249.
6. Boynton, S.S. and D.E. Daniel. 1985. Hydraulic conductivity tests on compacted clay. *Journal of Geotechnical Engineering*. Vol. 111, No. 4: 465-478.
7. Montgomery, R.J. and L.J. Parsons. 1989. The Omega Hills Final Cover Test Plot Study: Three-Year Data Summary. Presented at the 1989 Annual Meeting of the National Solid Waste Management Association, Washington, DC.
8. Zimmie, T.F. and C. La Plante. 1990. The effect of freeze-thaw cycles on the permeability of a fine-grained soil. *Proceedings, 22nd Mid-Atlantic Industrial Waste Conference*. Philadelphia, Pennsylvania: Drexel University.
9. Gilbert, P.A. and W.L. Murphy. 1987. Prediction/mitigation of subsidence damage to hazardous waste landfill covers. EPA/600/2-87/025 (PB87-175386). Cincinnati, Ohio: U.S. EPA.
10. Seed, R.B., J.K. Mitchell, and H.B. Seed. 1990. Kettlemam Hills waste landfill slope failure. II: Stability analyses. *Journal of Geotechnical Engineering*. Vol. 116, No. 4: 669-691.
11. Takasumi, D.L., Green, K.R., and R.D. Holtz. 1991. Soil-Geosynthetics Interface Strength Characteristics: A Review of State-of-the-Art Testing Procedures. *Proceedings, Geosynthetics 91*, Vol. 1, 87-100.
12. Seed, R.B., and R.W. Boulanger. 1991. Strength of HDPE—Clay Interface Shear Strengths: Compaction Effects. *Journal of Geotechnical Engineering*. Vol. 117, No. 4, 686-693.

## CHAPTER 3 GEOSYNTHETIC DESIGN FOR LANDFILL COVERS

### GENERAL COMMENTS ON DESIGN-BY-FUNCTION

Geosynthetics (GS), like all engineering materials, are capable of being evaluated using a design-by-function approach which includes a traditional factor-of-safety (FS) concept. The primary function of the geosynthetic depends upon its location in the facility. The usual requirements for waste containment systems are given in Table 3-1.

**Table 3-1. Customary Primary Functions of Geosynthetics Used in Waste Containment Systems**

Type of Geosynthetic	Primary Function				
	Separate	Reinforce	Filter	Drain	Barrier
Geomembrane					●
Geotextile	●	●	●	●	
Geonet				●	
(Geo) pipe				●	
Geocomposite				●	
Geogrid		●			

Upon selection of the primary function, the FS should be calculated in the same manner as for any other engineering material:

$$FS = \frac{\text{Allowable (Test) Value}}{\text{Required (Design) Value}} \quad (1)$$

In the above equation, the test values usually come from ASTM Committee D35 on Geosynthetics, or some other standardization group. The design values come from a site-specific situation that utilizes relevant aspects of geotechnical, hydraulic, polymer, or environmental engineering principles or from the appropriate governing regulations. The actual magnitude of the FS is a reflection of the degree of certainty of the design as well as the implications of the system's nonperformance.

### GEOMEMBRANE DESIGN CONCEPTS

For the design of a geomembrane in a landfill cover there are at least four general considerations: liner compatibility, vapor transmission (water and methane),

biaxial stresses via subsidence, and planar stresses mobilized by friction. Each will be described separately below.

#### **Geomembrane Compatibility**

Since the liquid interfacing the geomembrane liner is generally water, there is usually no need for EPA 9090 chemical compatibility testing, except in unusual circumstances. Some other tests that might be considered, however, are the following:

- Dimensional stability test via ASTM D-1204
- Resistance to soil burial via ASTM D-3083
- Water extraction test via ASTM D-3083
- Volatile loss test via ASTM D-1203
- Biological resistance test via ASTM G-22
- Fungus resistance test via ASTM G-21

The use of these tests is required on a site-specific and geomembrane-specific basis.

#### **Vapor Transmission**

Testing of water vapor transmission through geomembranes is performed via ASTM E-96. The EPA technical resources document of September 1988 (1) gives the following values for the indicated geosynthetic materials:

PVC (polyvinyl chloride)	- 30 mil - 1.9 g/m <sup>2</sup> -day
CPE (chlorinated polyethylene)	- 40 mil - 0.4 g/m <sup>2</sup> -day
CSPE (chlorylsulfonated polyethylene)	- 40 mil - 0.4 g/m <sup>2</sup> -day
HDPE (high density polyethylene)	- 30 mil - 0.02 g/m <sup>2</sup> -day
HDPE	- 98 mil - 0.006 g/m <sup>2</sup> -day

The conversion from g/m<sup>2</sup>-day to gal/acre-day is 1 to 1.07.

A related measurement is methane (CH<sub>4</sub>) gas transmission through geomembranes. This lighter-than-air gas will rise up from the waste and interface with the geomembrane. Methane gas transmission rates for dif-

ferent geomembranes have been reported in EPA's technical resources document as follows:

- PVC - 10 mil - 4.4 ml/m<sup>2</sup>-day-atm.
- 20 mil - 3.3 ml/m<sup>2</sup>-day-atm.
- LLDPE (linear low density polyethylene)
- 18 mil - 2.3 ml/m<sup>2</sup>-day-atm.
- CSPE - 32 mil - 0.27 ml/m<sup>2</sup>-day-atm.
- 34 mil - 1.6 ml/m<sup>2</sup>-day-atm.
- HDPE - 24 mil - 1.3 ml/m<sup>2</sup>-day-atm.
- 34 mil - 1.4 ml/m<sup>2</sup>-day-atm.

**Biaxial Stresses via Subsidence**

As the waste beneath the closure subsides, differential settlement is likely to occur. Thus a factor-of-safety formulation of  $FS = \sigma_{allow} / \sigma_{reqd}$  is necessary. This situation has been modeled (see Appendix A, *Stability and Tension Considerations Regarding Cover Soils on Geomembrane Lined Slopes*), giving rise to the following formula for required strength ( $\sigma_{reqd}$ ):

$$\sigma_{reqd} = \frac{2 D L^2 \gamma_{cs} H_{cs}}{3 t (D^2 + L^2)}$$

- where  $\gamma_{cs}$  = unit weight of cover soil
- $H_{cs}$  = height of cover soil
- $t$  = thickness of geomembrane
- $D, L$  = see Figure 3-1

The allowable strength  $\sigma_{allow}$  of the candidate geomembrane must be evaluated in a closely simulated test, e.g., GRI's GM-4 entitled "Three Dimensional Geomembrane Tension Test." Figure 3-2 presents the response to this test of a number of common geomembranes used in closure situations.

**Planar Stresses via Friction**

In addition to the above out-of-plane stresses, the cover soil over the geomembrane might develop greater frictional stresses than the soil material beneath it. This happens particularly if a wet-of-optimum clay is placed beneath. Again a factor-of-safety formulation is formed by comparing the allowable strength ( $T_{allow}$ ) to the required strength ( $T_{reqd}$ ) but now in force units rather than stress units, e.g.,  $FS = T_{allow} / T_{reqd}$ . The required geomembrane tension can be obtained by the equation given in Figure 3-3 (see Appendix A for a more detailed discussion).

- where  $CaU, CaL$  = adhesion of the material upper and lower of the geomembrane
- $\delta_U, \delta_L$  = friction angle of the material upper and lower of the geomembrane
- $\omega$  = slope angle
- $L$  = slope length
- $W$  = unit width of slope

- $\gamma_{cs}$  = unit weight of cover soil
- $H_{cs}$  = height of cover soil

When calculated, the value of  $T_{reqd}$  in Figure 3-3 is compared to the  $T_{allow}$  of the candidate geomembrane. This value is currently taken from ASTM D-4885, the wide-width tensile test for geomembranes. Note that this value must be suitably adjusted for creep, long-term degradation, and any other site-specific situations that are considered relevant.

**GEONET AND GEOCOMPOSITE SHEET DRAIN DESIGN CONCEPTS**

Geonets and/or geocomposite drains are often used as surface water drains located immediately above the geomembrane in a landfill closure system. There are three aspects to the design that require attention: material compatibility, crush strength, and flow capability.

**Compatibility**

Since the liquid being conveyed by the geonet or drainage geocomposite is water, EPA 9090 tests usually not warranted. The polymers from which these products are made are polyethylene (PE), polypropylene (PP), high-impact styrene (HIS) or other long-chain molecular structures that have good water resistance and long-term durability when covered by soil.

**Crush Strength**

The crush strength of the candidate product must be evaluated by comparing an allowable strength to a required stress, i.e.,  $FS = \sigma_{allow} / \sigma_{reqd}$ . The allowable strength is taken as the rib lay-down for geonets and the telescoping crush strength for drainage geocomposites. Figure 3-4 illustrates common behavior for geonets and geocomposites. The test methods currently recommended are GRI GN-1 for compression behavior of geonets and GRI GC-4 for drainage geocomposites, i.e., for sheet drains.

The required stress is the dead load of the cover soil plus any live loads that may be imposed, such as construction and maintenance equipment.

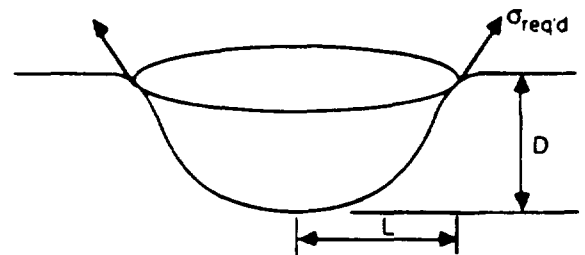

Figure 3-1. Required strength.

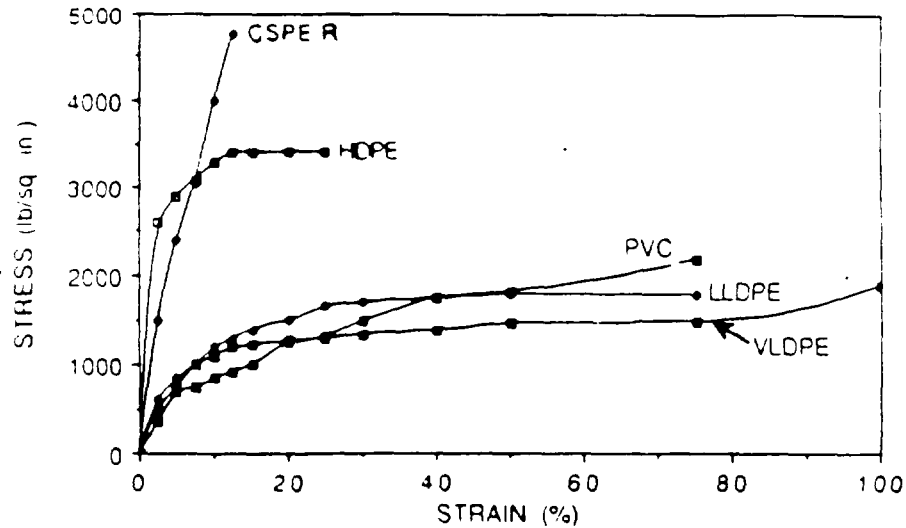
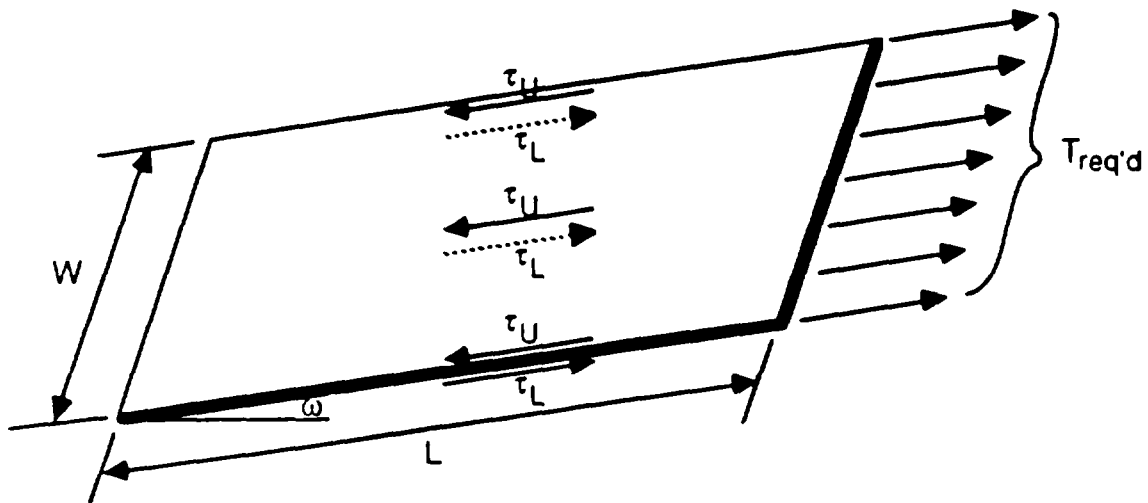

Figure 3-2. Response of common geomembranes to the three-dimensional geomembrane tension test.



$$T_{req'd} = \left[ \left( c_{a_U} - c_{a_L} \right) + \gamma_{cs} H_{cs} \cos \omega \left( \tan \delta_U - \tan \delta_L \right) \right] L \cdot W$$

Figure 3-3. Required geomembrane tension.

**Flow Capability**

The planar flow capability of the geonet or drainage geocomposite must be assured via a formulation such as  $FS = q_{allow}/q_{reqd}$ . The allowable flow rate is obtained using ASTM D-4716, the transmissivity test. The device is shown schematically in Figure 3-5, along with the type of data generated. Note that the value of the flow rate obtained must be modified according to site-specific condi-

tions if these conditions are not properly simulated in the test.

For the required flow rate,  $q_{reqd}$ , site-specific conditions must also be considered. To obtain this value, a water balance method that takes into account precipitation, runoff, evapotranspiration, and infiltration is required. The HELP model, presented in detail in Chapter 8, is recommended for obtaining this value.

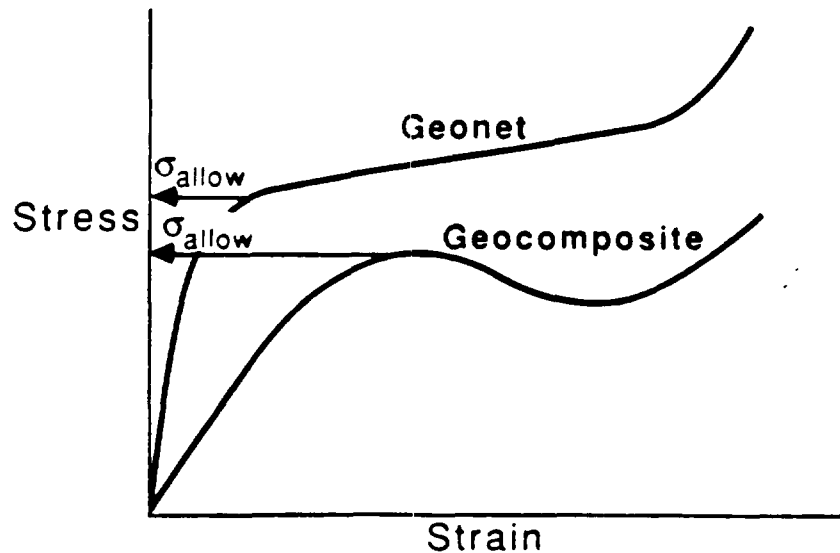

Figure 3-4. Common crush strength behavior for geonets and geocomposites.

### GEOPIPE AND GEOCOMPOSITE EDGE DRAIN DESIGN CONCEPTS

All of the infiltrating surface water that is collected from the geonet or geocomposite sheet drain is conveyed to the perimeter of the closure, where it is collected in a perforated pipe or in a geocomposite edge drain. The design of the geopipe or geocomposite edge drain must consider compatibility, crush strength, and flow rate.

#### Compatibility

With surface water as the flow medium, EPA 9090 chemical resistance testing is usually not required. Plastic pipe is usually unplasticized PVC or HDPE, and almost all edge drains are HDPE. Thus, resistance to water is very good.

#### Crush Strength

The formulation for crush strength is straightforward,  $FS = \sigma_{allow} / \sigma_{reqd}$ . The allowable strength for plastic pipe is ASTM D-2412 and for geocomposite edge drain cores is GRI's GC-4. The response to both types of materials is very crisp (see Figure 3-6).

The required strength is the dead weight of the cover soil plus any live loads that might be superimposed onto the system. Truck traffic around the edge of the closure should be considered in this regard.

#### Flow Rate

The required flow rate of the pipe or edge drain is the cumulative flow coming from the geonet or sheet drain above the geomembrane. Furthermore, this flow is again cumulative within the pipe or edge drain and is at its maximum at the drainage outlet. Required flow rate will probably dictate the frequency and location of outlets.

To determine the allowable flow rate of pipes, the Manning formula is usually used with a roughness coefficient for smooth plastic pipe of 0.015. This is straightforward hydraulics engineering for pipes flowing partially full. For geocomposite edge drains, the ASTM D-4716 test described earlier is recommended.

### GEOTEXTILE FILTER DESIGN CONSIDERATIONS

Geotextiles have the greatest flexibility to serve a number of different functions. In a landfill closure, one of the most important is as a filter allowing water to enter a drainage material composed of stone, geonet, geocomposite, or perforated pipe. In selecting a geotextile for this purpose, compatibility, hydraulic conductivity, soil retention, and long-term clogging all must be addressed.

#### Compatibility

The vast majority of geogrids are PP or PET. Both of these polymers are very stable in contact with water and have demonstrated good durability properties. Generally, there is no need to perform an EPA 9090 chemical compatibility test. The geotextile literature is abundant with related tests assessing long-term behavior and performance (2).

#### Permeability

A geotextile filter must have sufficient openings to allow the water to enter the drain without developing excess pore water pressure in the upstream soil. Such pressures could mobilize cover soil instability. The flow rate design is based on permittivity,  $\psi = k_n / t$ , where  $k_n$  = hydraulic conductivity normal to the fabric, and  $t$  = the fabric thickness. As usual, a  $FS = \psi_{allow} / \psi_{reqd}$  is formulated. The allowable value is obtained from ASTM D-4491 but the

## ASTM D-4716 Flow Rate Test

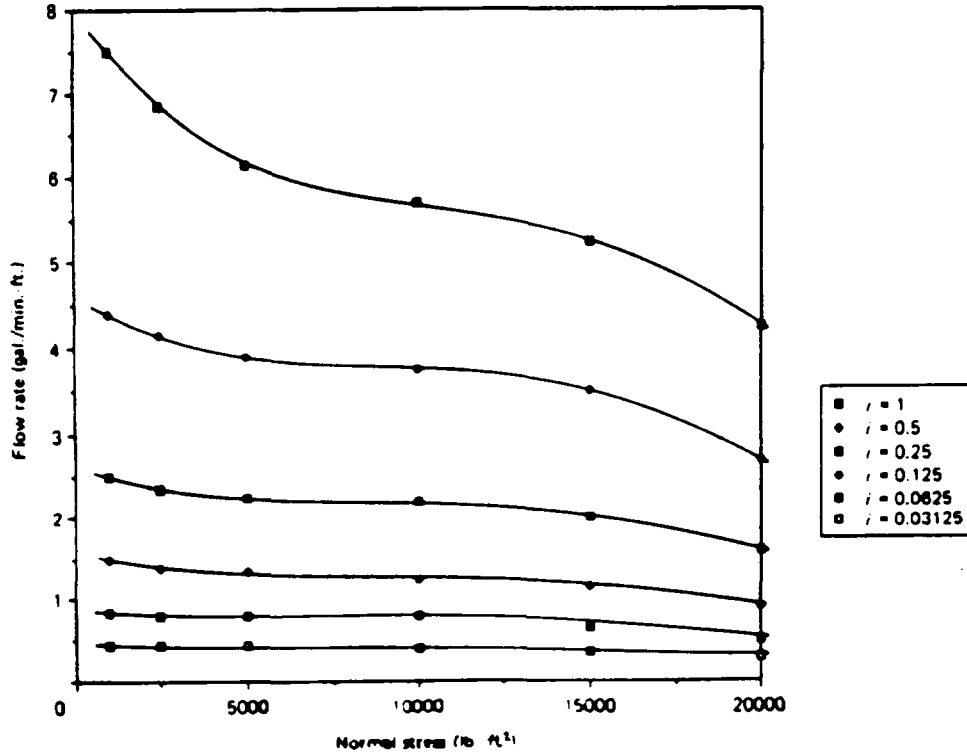
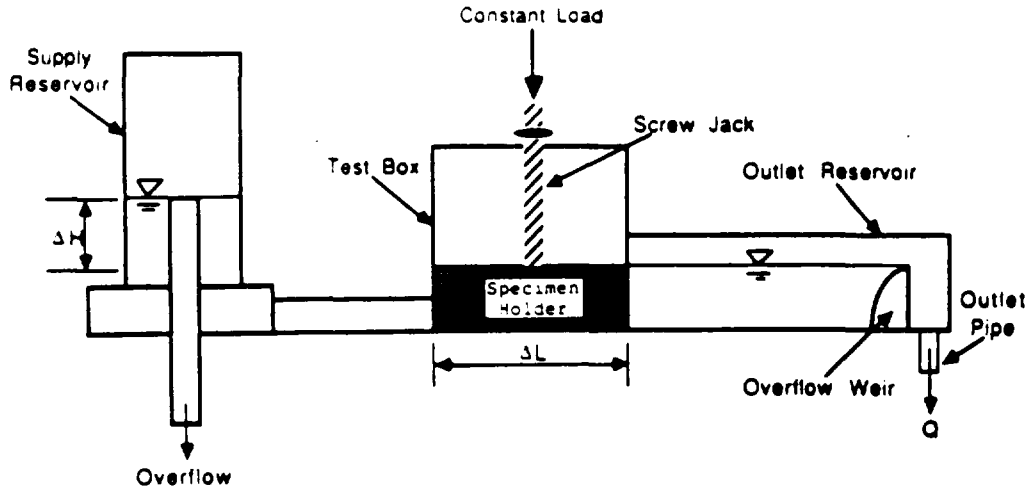

Figure 3-5. ASTM D-4716 flow rate test.

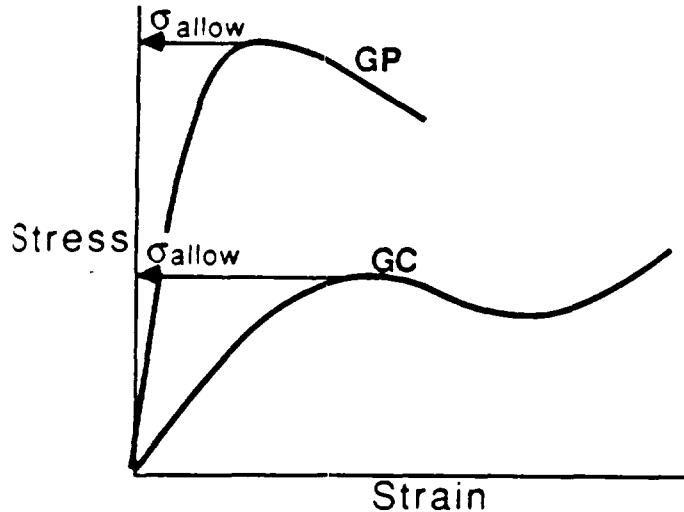

Figure 3-6. Crush strength of geopipe and geocomposite edge drain cores.

result must be modified to site-specific conditions using partial factors of safety. The required value comes from a water balance method, e.g., the HELP computer code (see Chapter 8).

#### Geotextile Soil Retention

The geotextile filter must retain the upstream cover soil, thereby requiring the voids to be suitably small. Since the desired retention is the opposite of permittivity, the design must balance the two conflicting design considerations. Fortunately, there are about 4,000 commercially available geotextiles to choose from, thus a design can generally be satisfied by a number of products. The factor-of-safety formulation is as follows:

$$FS = \lambda d_{85}/O_{95}$$

where  $\lambda$  = 2 to 4  
 $d_{85}$  = the 95 percent finer soil size  
 $O_{95}$  = the geotextile's 95 percent opening size

The former value ( $d_{85}$ ) is obtained by dry sieving the upstream soil, the latter value is obtained by sieving glass beads through the fabric as per ASTM D-4751.

#### Geotextile Clogging Evaluation

There are four laboratory tests to evaluate long-term geotextile clogging by upstream soil particles:

- Gradient ratio test (GR).
- Long-term flow test (LTF).
- Hydraulic conductivity ratio test (HCR).
- Fine fraction filtration test ( $F^3$ ).

The first two tests are established in the literature and are recommended for geotextiles used in landfill covers. The latter two tests are experimental and aimed at situations of relatively severe clogging. In general, use of geotextile filters in landfill closures as discussed in this chapter is *not* a particularly demanding design situation.

#### GEOGRID, OR GEOTEXTILE, COVER SOIL REINFORCEMENT

Due to the relatively low interface friction angle of many geomembranes, there have been some instances of cover soils sliding off the liner in a gradual (or sometime abrupt) manner. Many of these situations can be avoided using geogrid, or geotextile reinforcement. The procedure is sometimes called "veneer reinforcement." The design is based on a factor-of-safety formulation of  $F = T_{allow}/T_{reqd}$ . The allowable strength is obtained from a wide-width tensile strength test such as ASTM D-4595. This value, however, must be reduced for such site-specific conditions as installation damage, creep, and long-term degradation.

Based on an infinite slope analysis, the required strength of the geogrid (or geotextile) is given by the equation in Figure 3-7. Note that the analysis includes a seepage force "S" and an earthquake force "E." Both are, of course, site specific and, if large, can easily dominate the design.

#### GEOTEXTILE METHANE GAS VENT

Beneath the liner system in a landfill closure, gases lighter than air will accumulate and gradually exert pressure on the underside of the geomembrane. In some known cases, four feet of cover soil have been cast off of

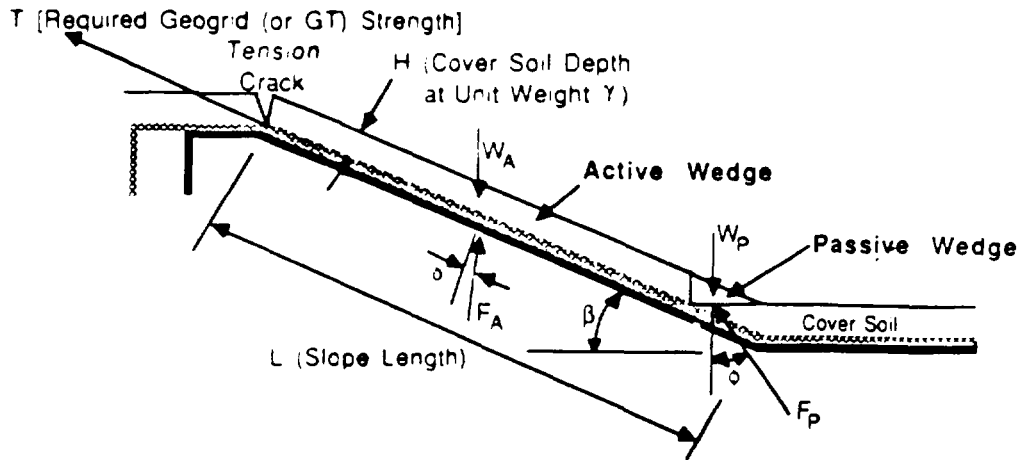

$$T = \left( LH - \frac{2H^2}{\sin 2\beta} \right) \times \gamma \times \frac{\sin(\beta - \delta)}{\cos \delta} - \left( \frac{H^2}{\sin 2\beta} \right) \times \gamma \times \frac{\sin \phi}{\cos(\beta + \phi)} + S + E$$

where

S = Possible Seepage Force

E = Possible Earthquake Force

Figure 3-7. Required strength of geogrid for cover soil reinforcement.

the geomembrane and a geomembrane "whale" has appeared above the ground surface. To avoid such occurrences, these landfill gases (mainly methane) must be conveyed along the underside of the liner in a uniform upward gradient to a high point where the geomembrane is penetrated. Here the gases are vented, flared, or captured for energy use.

While not widely implemented, geotextiles with adequate planar transmissivity could serve this purpose. The design-by-function concept is again used to select the proper material, where  $FS = q_{allow}/q_{reqd}$ . The required gas flow rate is very site specific, but is available in the landfill gas literature. The allowable gas flow rate uses an adapted form of ASTM D-4716, but with radial rather than parallel flow (see Figure 3-8).

## REFERENCES

1. U.S. EPA 1988. U.S. EPA guide to technical resources for the design of land disposal facilities. EPA guidance document: Final covers on hazardous waste landfills and surface impoundments. EPA/530-SW-88-047.
2. Koerner, R.M., ed. 1989. Durability and aging of geosynthetics. Elsevier Applied Science Publishers. 332 pp.
3. Koerner, R.M., J.A. Bove, and J.P. Martin. 1984. Water and air transmissivity of geomembranes, Vol. 1. No. 1, pp. 57-74.

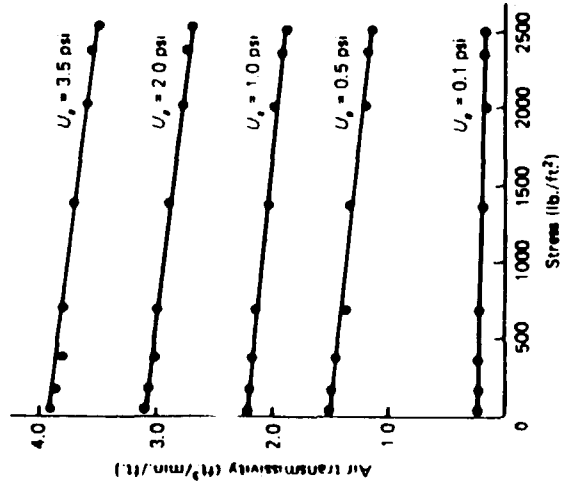
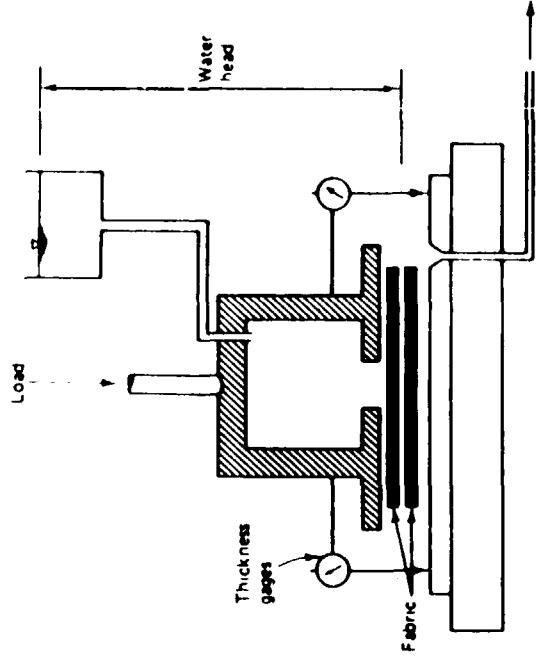

Figure 3-8. Allowable gas flow as adapted from ASTM D-4716 (3).

## CHAPTER 4

### DURABILITY AND AGING OF GEOMEMBRANES

#### POLYMERS AND FOUNDATIONS

There is an almost infinite variety of polymeric geomembranes or flexible membrane liners—that can be used in landfill cover situations. The major groups are:

- Thermoset elastomers (which are rarely used due to seaming difficulties)
- Thermoplastic
  - polyvinyl chloride (PVC)
  - chlorosulphonated polyethylene (either nonreinforced or reinforced)—CSPE or CSPE-R
  - ethylene interpolymer alloy (reinforced)—EIA-R
  - very low density polyethylene (VLDPE)
  - high density polyethylene (HDPE)
- Bituminous (which are rarely used in the United States)

Geomembranes in the thermoplastic group are currently most frequently utilized. These particular polymer resins, however, are used in a formulation to arrive at the final compound. Table 4-1 presents the formulations typically used.

**Table 4-1. Typical Formulations of Geomembranes**

Geomembrane Type	Resin (%)	Plasticizer (%)	Carbon Black and/or Filler		Additive* (%)
			(%)	(%)	
PVC	45-50	35-40	10-15		3-5
CSPE	45-50	2-5	45-50		2-4
EIA	70-80	10-25	5-10		2-5
VLDPE	96-98	0	2-3		1-2
HDPE	97-98	0	2-2.5		≤ 1

\*refers to antioxidant, processing aids, and lubricants.

When assessing durability and aging of membranes, each component of the compound within a particular geomembrane must be addressed. Obviously, those formulations that contain no plasticizers or fillers have a less complicated set of mechanisms to consider, e. g. , VLDPE or HDPE. There is a wealth of information in the literature on "resin" behavior, but little on the durability of specific geomembrane formulations. For this reason, this

section will treat each possible degradation mechanism individually, before dealing with synergistic effects and lifetime prediction methods.

#### MECHANISMS OF DEGRADATION

Eight separate mechanisms of degradation are described in this section. Some of the major ones, such as ultraviolet degradation, can be eliminated by soil covering and others, such as radiation or chemical degradation, are not very likely due to the geomembrane's position in the closure system above the waste.

##### *Ultraviolet Degradation*

By virtue of its short wavelength components, sunlight can enter into a polymer system and (with sufficient energy) cause chain scission and bond breaking. Figure 4-1 shows the wavelength spectrum of visible and ultraviolet radiation. Superimposed on the figure are the most sensitive wavelengths of some commercially used polymers for geosynthetic materials:

- PE ≤ 300 nm
- PET ≤ 325 nm
- PP ≤ 370 nm

The mechanism of ultraviolet degradation is well understood and two approaches are taken to minimize its effects. Carbon black is added to the formulation, as a blocking or screening agent, and chemical stabilizers are added as scavenging agents. To eliminate degradation of geomembranes in closure situations, however, the geomembrane should be placed, seamed, and inspected, and then covered with soil soon afterward.

##### *Radiation Degradation*

Clearly, radiation degradation is only of concern if there is radioactive waste in the facility. Both  $\gamma$ -rays and neutrons within waste can degrade polymers and cause chain scission and bond breaking. While there is a real concern for high-level and transuranic wastes, low-level waste is substantially less radioactive, and may not be a problem.

##### *Chemical Degradation*

Various chemicals can be aggressive to certain types of geomembranes. For this reason, EPA has developed an entire test protocol called EPA 9090 testing for assessing

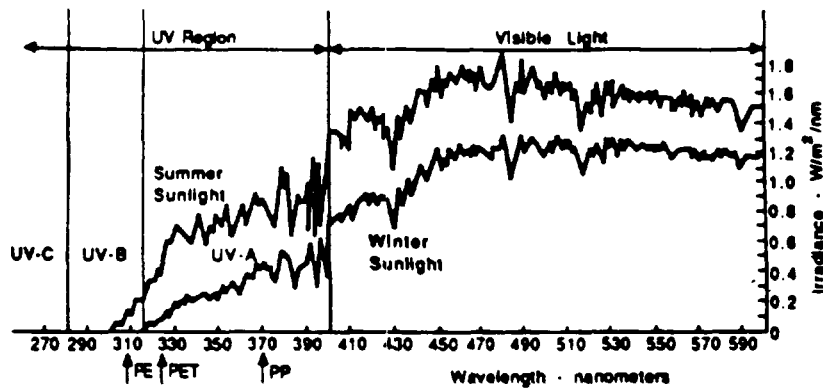

Figure 4-1. Wavelength spectrum of visible and ultraviolet radiation.

chemical resistance. While testing is necessary for liners beneath the waste in contact with leachate, the closure liner should only interface with water, which comes from seepage through the cover soil placed above it. Thus, chemical degradation generally should not be an issue with the thermoplastic geomembranes used in landfill closures.

#### Swelling Degradation

All polymers swell when exposed to liquid, including water. Generally, HDPE swells the least, PVC swells the most, and the other geomembranes fall between these two extremes. The swelling process is largely reversible and does not necessarily lead to degradation. However, swelling may cause secondary actions that could lead to other synergistic effects.

#### Extraction Degradation

If one, or more, of the components of a geomembrane formulation are extracted, the remaining material will obviously be compromised. For example, if swelling leads to bond breaking of the plasticizer within a PVC formulation, the plasticizer could be extracted over time. This phenomenon would decrease the elongation capability of the geomembrane with respect to tension, tear, and puncture modes of failure. The closest tests available to estimate extraction are the following:

- ASTM D3083 for water extraction.
- ASTM D1203 for volatile loss.

Other tests, or test procedures, could be required on the basis of a site-specific and material-specific basis.

#### Delamination Degradation

For geomembranes that are fabricated in layers, e. g. , scrim reinforced or multi-ply types, there is a possibility that liquid can enter between the layers causing delamination and premature failure.

To prevent delamination, the edges of multi-layered geomembranes should be properly sealed in the factory

and have no scrim exposed. If the sheets are trimmed in the field, the exposed edges should be "flood coated" with a heavy bodied solvent. An ASTM test on ply adhesion, ASTM D413, should be performed on the material.

#### Oxidation Degradation

Oxidation of polymers caused by the gases or liquids interfacing with the geomembrane is unavoidable. The oxygen, over time, will enter into the polymer structure and can react with various components in the particular formulation. All geomembranes (and all geosynthetics) are subject to this type of oxidation mechanism. The following equation illustrates this mechanism for polyethylene degradation:

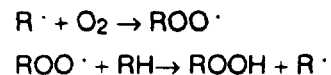

where  $R \cdot$  = free radical  
 $ROO \cdot$  = hydroperoxy free radical  
 $RH$  = polymer chain  
 $ROOH$  = oxidized polymer chain

The rate of the reaction is very site and polymer specific and is usually addressed experimentally. The testing procedure will be discussed in the section on accelerated testing methods.

To minimize the oxidation reaction, the polymeric formulation contains various anti-oxidants which scavenge (i.e. , neutralize) the free radicals. The amount of anti-oxidants that can be added, however, is limited, and once it is utilized, the oxidation process will proceed depending on site-specific and geomembrane-specific conditions.

#### Biological Degradation

Microorganism degradation of the "resin" portion of the various geomembrane formulations is probably not a problem. There is no literature available concerning bac-

terial or fungal attack of high molecular weight resins. Microorganisms may, however, interact with the plasticizers and/or fillers used in certain geomembranes. Two ASTM tests can be used to detect this type of degradation: G21 deals with resistance of plastics to fungi and G22 is the complementary test for bacterial resistance.

Higher forms of biological life, like burrowing animals, may be a much more serious problem. A muskrat, or other small mammal, interested in burrowing through a geomembrane, could easily do so. The hardness of the geomembrane versus the animal's teeth structure, force, and hardness need to be considered. If such animals are in the vicinity of the landfill, one might consider using a rock "bio-barrier" above the geomembrane as per EPA guidance.

### **SYNERGISTIC EFFECTS**

The eight degradation mechanisms discussed in the previous section—ultraviolet, radiation, chemical, swelling, extraction, delamination, oxidation, and biological—can also interact to cause numerous complex effects. In addition, there are three situations that should be addressed in any discussion on aging of polymeric materials: elevated temperature, applied stresses, and long exposure.

#### ***Elevated Temperature***

All of the previously mentioned degradation processes will be more severe at higher temperatures than at lower temperatures. Activation energy, as will be discussed in the section on Arrhenius modeling, is clearly a function of elevated temperature. Thus, a given formulation of a specific geomembrane will have a shorter lifetime in the southern states (all other things than temperature being equal) than in the northern states. A quantification of this amount, however, requires experimentation and appropriate modeling of the situation.

#### ***Applied Stresses***

It seems intuitive that the lifetime of a geomembrane in a relaxed state would be different than that of the same geomembrane under stress. Thus, modeling of a given situation should somehow take stresses into account. At a minimum, compressive stresses should be assessed; however, tensile and shear stresses (for liners on side slopes) and out-of-plane bending stresses (for liners in closures over subsiding waste) are also likely and should be considered. Simulating the magnitude and the type of stresses is very difficult and requires making many assumptions.

#### ***Long Exposure***

Landfill closures are designed (at the minimum) for 30-year postclosure care periods. Beyond this time frame, the facility's status is questionable and inquiries often arise as to ultimate ownership and responsibility for main-

tenance and repairs. To alleviate some of these concerns, it would be useful to quantify in the planning stages how long a geomembrane will last before its properties are degraded beyond serviceability. The longer the geomembrane's lifetime, the easier it will be to deal with these issues.

### **ACCELERATED TESTING METHODS**

A number of accelerated testing methods in the open literature predict the lifetime of polymeric materials. Many of these sources are available in the plastic pipeline literature from the Gas Research Institute, the Plastic Pipe Institute, and related organizations. The reference list for "Long-Term Durability and Aging of Geomembranes" (see Appendix B) also contains many useful sources of information.

#### ***Stress Limit Testing***

Stress limit testing to obtain plastic pipe "design stress" is fairly well developed and widely implemented. It requires simulated environmental testing with sections of pressurized capped pipe at constant temperature. Figure 4-2 shows typical results where the service time of the pipe is selected and the design stress is obtained from the experimental curve.

#### ***Rate Process Method for Pipe***

In this experimental method for polyethylene pipe, constant stress tests are conducted at different elevated temperatures. The design life is selected, intersected with the site-specific temperature response curve, decreased by a suitable factor-of-safety, and then extended to obtain the allowable stress. The graph in Figure 4-3 shows pipe behavior at 80°C, 60°C, and 20°C. The behavior at 20°C must be extrapolated as per the details in the paper by Koerner, Halse, and Lord in Appendix B. (See Appendix B, "Long-Term Durability and Aging of Geomembranes.")

#### ***Rate Process Method for Geomembranes***

The rate process method (RPM) can be used to test geomembranes if the site-specific conditions are properly modeled. The curve in Figure 4-4 gives notched constant load test data in an aggressive incubation liquid. The method is not developed for utilization at this time.

#### ***Arrhenius Modeling***

Arrhenius modeling is the method most widely used by chemists and polymer engineers to predict the lifetime of polymeric materials. This type of modeling assumes that elevated temperature can be used to simulate time at a site-specific (and lower) temperature. This assumption is sometimes referred to as a temperature-time superposition concept. Figure 4-5 shows an example of a possible test device. In Arrhenius modeling, measuring a suitable reaction rate of the polymer at different temperatures produces a linear plot on an inverse temperature graph.

## STRESS LIMIT TESTING

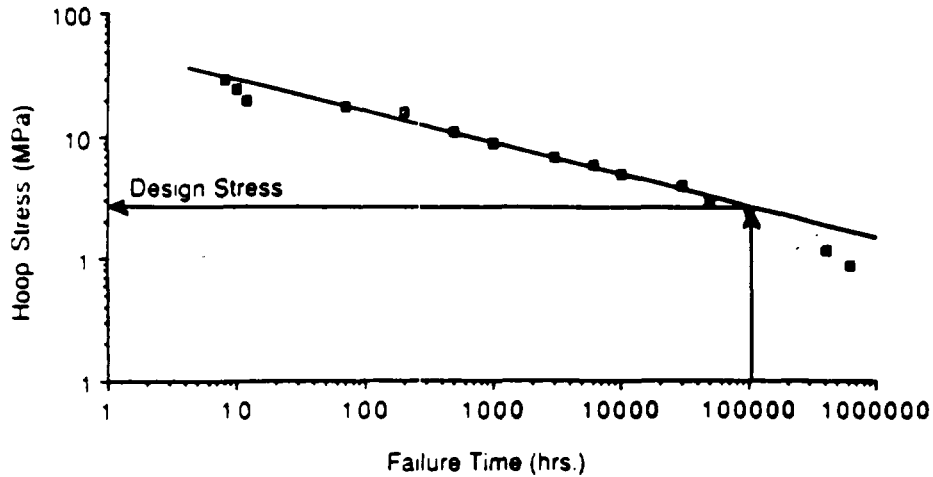

Figure 4-2. Stress limit testing for plastic pipe.

## RATE PROCESS METHOD FOR GEOPIPES

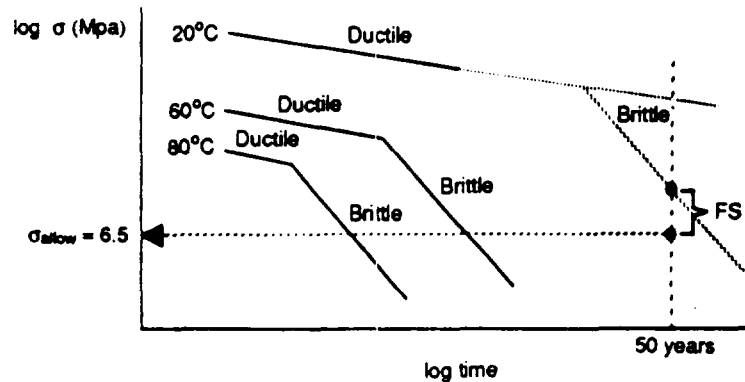

Figure 4-3. Rate process method for testing pipe.

The slope of the curve (if it is linear) can be used to extrapolate to the site-specific temperature. The calculations then follow along the lines given below.

Information regarding polyethylene shielding of electric cables is used here to demonstrate this technique. The reaction rate illustrated in Figure 4-6 is for 50 percent strength reduction of the original and unaged value using an impact test. (Any one of a number of tests could have been used.) The slope of the Arrhenius plot shown is:

$$\begin{aligned} \frac{E_{act}}{R} &= \frac{\ln 10^{-5} - \ln 10^{-2}}{0.00247 - 0.00198} \\ &= -14,000 \text{ (}^\circ\text{K)} \end{aligned}$$

To predict low-temperature behavior, consider the elevated temperature data point at:

$$1/T = 0.00213$$

$$T = 469^\circ\text{K}$$

$$T = 196^\circ\text{C}$$

and project this reaction rate to the site-specific temperature of 90°C. Using the Arrhenius equation,

$$\frac{Rr_1}{Rr_2} = e^{-\frac{E_{act}}{R} \left[ \frac{1}{T_1} - \frac{1}{T_2} \right]}$$

- where
- $Rr_1$  = reaction rate at temperature  $T_1$
  - $Rr_2$  = reaction rate at temperature  $T_2$
  - $E_{act}/R$  = slope of experimental curve
  - $T_1$  = experimental (test) temperature
  - $T_2$  = site-specific (desired) temperature

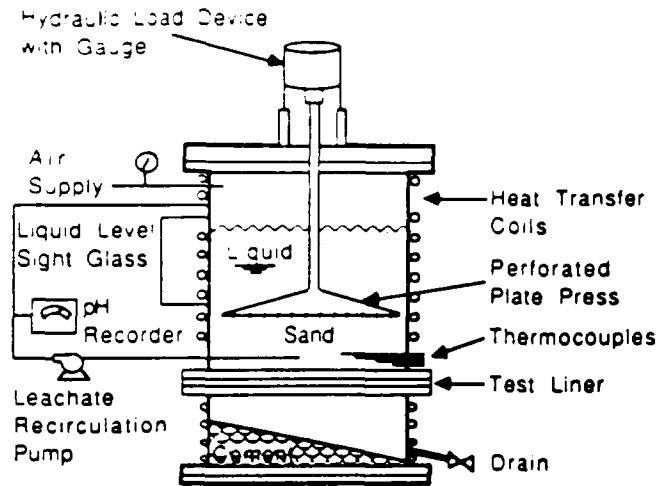

Figure 4-4. Rate process method for testing geomembranes.

#### RATE PROCESS METHODS FOR GMs

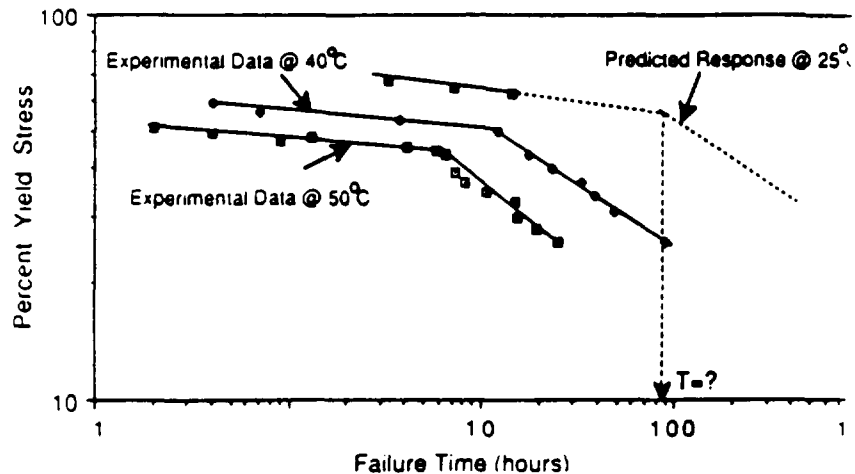

Figure 4-5. Testing device for Arrhenius modeling.

$$\frac{R_r @ 196}{R_r @ 90} = e^{-14,000 \left[ \frac{1}{469} - \frac{1}{363} \right]}$$

$$= 6,587$$

Since the reaction took 1,000 hours to complete at 196°C, the comparable reaction rate at 90°C would be:

$$\begin{aligned} R_r @ 90^\circ \text{C} &= 6,587 (1000) \\ &= 6,587,000 \text{ hrs} \\ &= 752 \text{ yrs} \end{aligned}$$

Because the temperatures of the experiments used in the example are quite high and quite limited (i. e., they are

bunched together), extrapolation down to the site-specific temperature mentioned may be invalid. One does not know which, if any, of the geomembrane properties will be amenable to the Arrhenius approach, but the various possibilities should be investigated on a project-specific basis and as a general research area.

#### Multi-Parameter Prediction

Using a number of experimental and field-measured response curves, it may be possible to generate a lifetime prediction method. Required (see the Hoechst reference in Appendix B) are the constant stress (Figure 4-7a), stress relaxation (Figure 4-7b), and field-measured strain

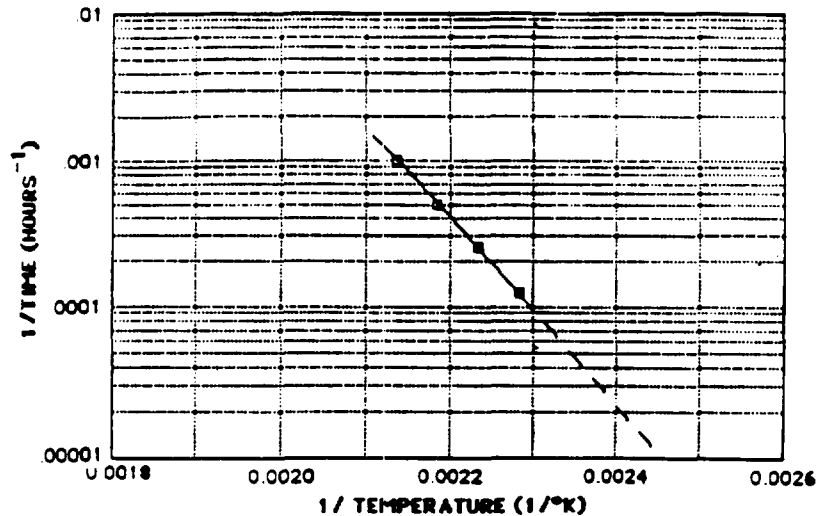

Figure 4-6. Reaction rate for impact testing of polyethylene shielding.

(Figure 4-7c) curves. By superposition of the proper temperature response curve and the appropriate strain response curve (laboratory and field), one can possibly project the lifetime of the considered geomembrane under three possible assumptions:

- No additional stress relaxation, curve (a)
- Intermediate stress relaxation, curve (b)
- Full stress relaxation, curve (c)

These results are each shown on the graph in Figure 4-7d. This technique is potentially useful, but requires a relatively large amount of experimental and field data.

### SUMMARY AND CONCLUSIONS

Durability and aging of geomembranes (and all geosynthetics) are important issues, especially when considering the situation of landfill covers beyond the 30-year

postclosure care period. Fortunately, most degradation processes are eliminated or greatly reduced by burying the geomembrane in soil soon after installation. Also, because the interfacing liquid is water and not leachate, as with the liner beneath the waste, there is little problem with chemical degradation. Long-term oxidation, however, is a degradation mechanism that can only be retarded (via anti-oxidants), but not eliminated, and, thus, is a focal parameter for experimental modeling.

Of the predictive models that have been reviewed, the Arrhenius modeling technique, which is under active investigation, is in the most widespread use. Equally interesting is the multi-parameter approach, but this method is much less developed. Whatever techniques are used, they are only laboratory prediction methods. Field feedback is necessary to establish better insight into degradation and aging issues involving polymeric geomembranes and other related geosynthetic materials.

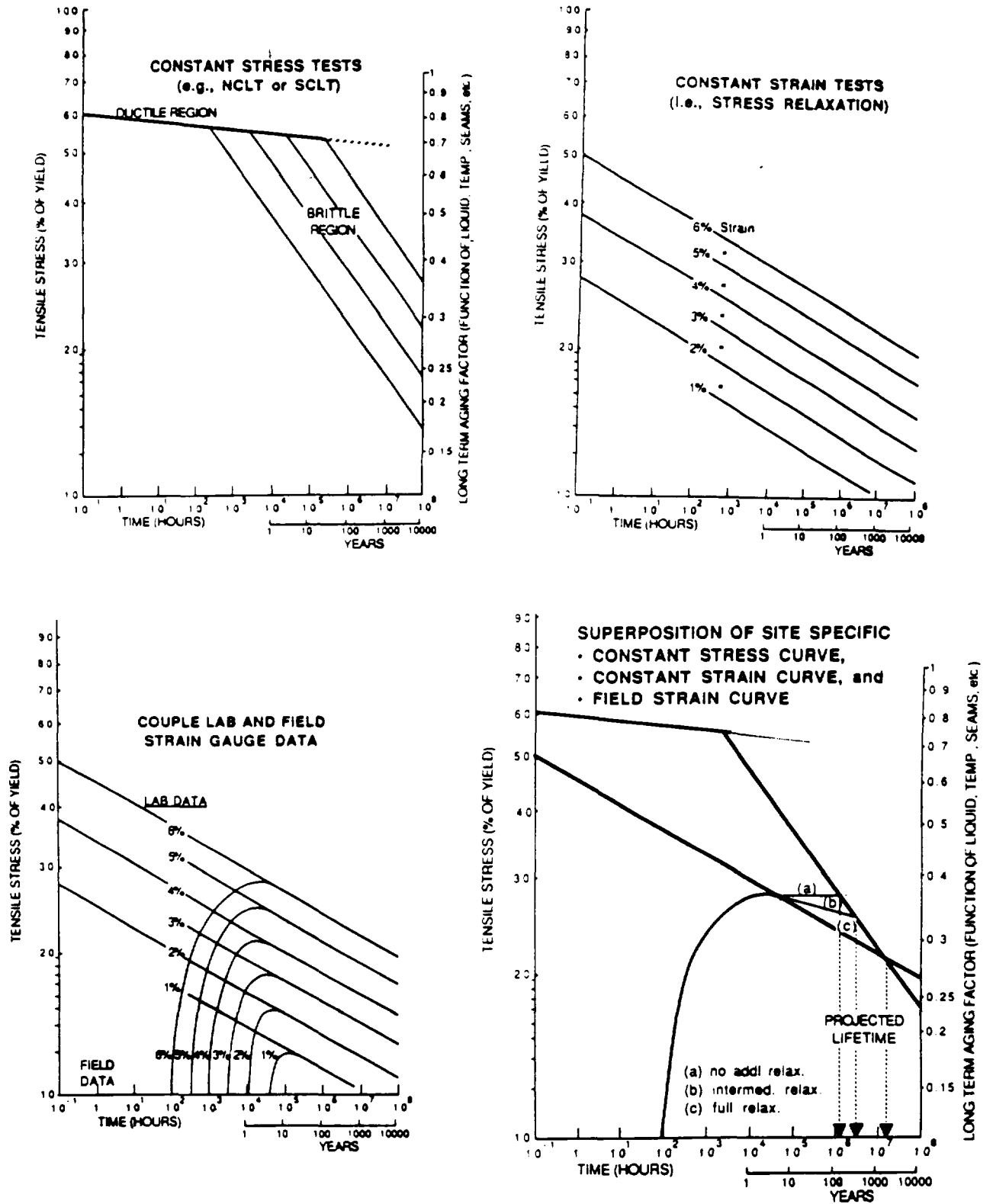

Figure 4-7. Experimental and field-measured response curves for multi-parameter lifetime prediction.

---

## **CHAPTER 5**

### **ALTERNATIVE COVER DESIGNS**

#### **INTRODUCTION**

The hazardous waste landfill cover designs developed and published by the U.S. Environmental Protection Agency (EPA) are generic in nature and intended to meet the regulatory criteria for covers on a national basis. This section reviews these designs to determine alternatives that would be acceptable to the regulatory community. This discussion will also review designs being considered by other agencies, such as the Nuclear Regulatory Commission (NRC).

#### **SUBTITLE C**

The basic acceptable generic design for hazardous waste landfills incorporates natural soil (clay), geomembrane, drainage, and vegetation layers. This generic design, however, does not take into account site-specific concerns, such as siting in arid areas where rainfall is very low. Under these conditions, a barrier layer composed of both a natural soil (clay) and a geomembrane layer probably would not be effective. The natural soil layer is designed to be placed "wet-of-optimum" to achieve the minimum hydraulic conductivity. When placed in a relatively dry environment, this layer will dry and crack, making it less effective. In selected cases, the newer bentonite blankets may be an acceptable alternative.

From a technical standpoint, the geomembrane may be the only barrier necessary. Site-specific considerations such as settlement/subsidence, environmental exposure, and other physical conditions may influence the thickness of the geomembrane required.

In selected cases, a vegetation layer alone may be demonstrated (via the Hydrologic Evaluation of Landfill Performance (HELP) model—see Chapter 8) to meet the criteria. In this case, a thicker soil layer may be required to assist in establishing the natural vegetation and to act as a storage reservoir for the infrequent but high intensity rainfall.

In summary, the design criteria were established for a national generic design. EPA is always interested in reviewing alternative designs that are innovative and utilize site-specific information. These alternative designs should be demonstrated to be equivalent in performance to the generic design proposed by EPA.

#### **SUBTITLE D**

While EPA has proposed some generic design considerations, Subtitle D facility designs will most likely be approved by individual states. Cover designs should be incorporated into the overall facility design, taking the bottom liner and liquids management strategy into account. Depending on site-specific considerations, designs based on natural soils as well as designs that resemble multilayer Subtitle C designs will be developed.

Municipal solid waste landfills usually require a daily cover of natural soils or other alternative materials. One possible use for postconsumer paper or unsaleable glass or glass culls may be for daily cover. Some enterprising individuals have developed a product made from shredded paper mixed with other proprietary ingredients that can be blown onto the surface of the waste to meet the requirements of daily cover. Foams and other materials have also been developed and evaluated for performance. Each of these materials has to be evaluated economically for site-specific use but may have advantages technically. For example, if the liquids management strategy for a landfill includes leachate recirculation, blown-on materials may allow more homogeneous distribution of the leachate. Another advantage is that blown-on materials will lose their barrier qualities as soon as the next layer is placed in the facility. Natural soils, on the other hand, do tend to act as barriers, which may cause leachate to seep out the side of the final cover.

Whatever alternate materials are used, they should be demonstrated to meet the technical requirements for daily cover.

#### **CERCLA**

CERCLA or Superfund cover designs are more complex from the standpoint of jurisdiction, where ARARs (discussed in Chapter 1) play an important part in selecting the final design. A multilayer cover system may be most environmentally desirable; however, other site-specific considerations may allow other types of designs. For example, early CERCLA covers have been constructed by regrading existing cover material, and adding small amounts of cover soil (usually about 6 inches) and, in

some cases, a rock armor. Due to the inequality and with the ARARs ruling, compliance with a RCRA multilayer has been more acceptable. Site-specific design changes have been approved after they were demonstrated to meet the intent of the regulations.

### OTHER COVER DESIGNS

The Department of Energy (DOE) and the NRC are both considering cover designs for landfills containing low level radioactive wastes. In general, these designs are comparable to the EPA's multilayer design, with some notable exceptions. One of the main criteria differences is based on the fact that DOE and NRC designs have to last for thousands of years due to the type of waste they are covering. The long-term nature of their designs has minimized the use of geosynthetics, since geosynthetics are thought to have a finite service life.

DOE will soon publish results of a study designed to develop an all natural soil cover system with a long service life (1). The study considered what type of soil would best qualify for each design aspect. A matrix was developed from which completed matrix designs will be proposed.

NRC also has been reviewing conceptual designs that use natural soils and have long life. Three cover designs are currently under investigation: (a) resistive layer barrier, (b) conductive layer barrier, and (c) bioengineering barrier (2). These designs are being assessed in large (21 x 14 x 3 m [70 x 45 x 10 in.] each) lysimeters in Beltsville, Maryland. The resistive layer barrier, shown in Figure 5-1, consists of compacted natural soils or clay.

The resistive layer depends on the low hydraulic conductivity of the compacted layer to minimize any potential moisture interaction with the waste.

The conductive layer barrier, shown in Figure 5-2, makes use of the capillary barrier phenomena to increase the moisture content above the interface and to divert water away from and around the waste (3). The capillary barrier is established when coarse grain soils are sandwiched between fine grain sediments. Experiments have shown that the greater the contrast in the permeability between the two layers, the more effective the barrier. A second fine grain soil layer would direct water away from the gravel layer under saturated conditions.

It should be noted that NRC considers these two conceptual designs unacceptable where appreciable subsidence may take place (2). This failure potential in the above two designs necessitated the development of an easily repairable surface barrier to be used until major settlement/subsidence activities had ceased. The surface barrier could be easily repaired during settlement/subsidence time period, after which a more permanent barrier could be installed. The bioengineering management cover system (Figure 5-3) was the result. This cover system utilizes a combination of engineered enhanced runoff and stress vegetation, e.g., Pfitzer junipers, growing in an overdraft condition to control deep water percolation through cover systems. Stress vegetation are grasses, trees, and shrubs that can survive when under stress, such as lack of water. Early results from the field indicate this system to be very effective in controlling liquid movement into or out of the waste management unit.

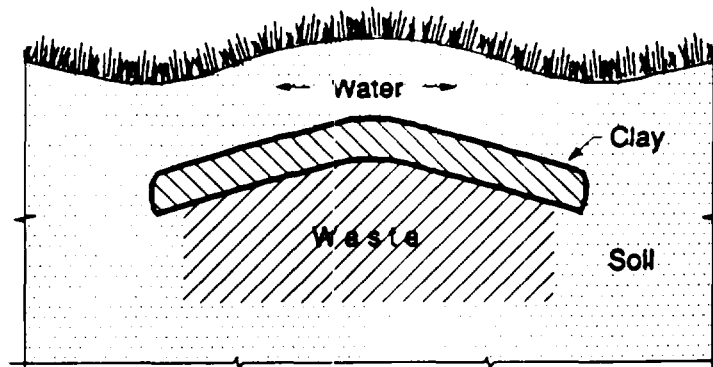

Figure 5-1. Resistive layer barrier.

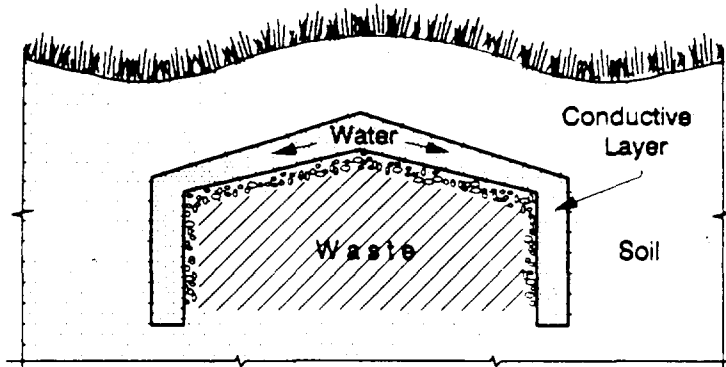

Figure 5-2. Conductive layer barrier.

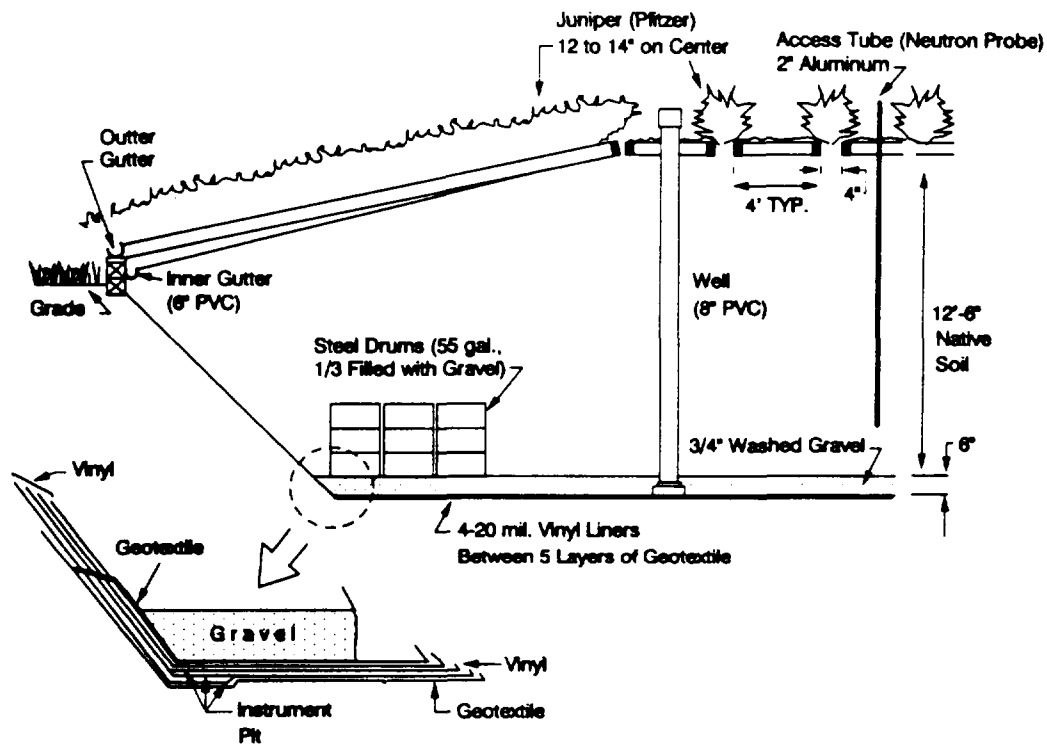

Figure 5-3. Side view of bioengineered lysimeter. Surface runoff is collected from both engineered surface and soil surface. Soil moisture content is measured with neutron probe. Water table is measured in well.

## REFERENCES

1. Identification and ranking of soils for UMTRA and LLW disposal facility covers. U.S. Army Corps of Engineers, Waterways Experiment Station. Unpublished.
2. O'Donnell, E., R.W. Ridky, and R.K. Schulz. 1990. Control of water infiltration into near surface LLW disposal units. Progress report on field experiments at a humid region site, Beltsville, MD. Waste Management '90 Tucson, Arizona, February.
3. Zunker, J.F. 1930. Das Verhalten des Bodens Zum Wasser In: E. Blanck, ed. Handbuch Der Bodenlehr. V. 6. Berlin: Verlag von Julius Springer, pp. 66-220.

---

## CHAPTER 6

### CONSTRUCTION QUALITY ASSURANCE FOR SOILS

#### INTRODUCTION

Construction quality assurance (CQA) is critical for producing engineered cover systems that will perform satisfactorily. The critical CQA issues for soils used in cover systems are:

- Control of the soil materials used to build various components of the cover system.
- Control of subgrade preparation.
- Control of the placement and compaction of soils.
- Protection of the soil during and after construction.
- Use of test pads in the CQA process.

This chapter examines each of these CQA issues. An EPA guidance document (1) provides general information concerning CQA, including responsibilities of the contractor and inspector. In general, the purpose of CQA is to provide observations and tests that assist in evaluating whether the construction has been performed in accordance with specifications. Accordingly, each CQA program must be tailored to the specific construction specifications for a given project. The sections that follow discuss general principles that should be considered when developing a CQA plan.

#### MATERIALS

The most important and useful quality control (QC) tests for soil materials used in cover systems are Atterberg limits, percentage of fines, percentage of gravel, and the maximum size of the largest stones or clods of clayey soil.

##### *Atterberg Limits*

The liquid and plastic limits or Atterberg limits of a soil, which are measured with ASTM Method D4318, can be useful indicators of the suitability of a soil for a specified purpose. The plasticity index (PI) of a soil is defined as the liquid limit minus the plastic limit and is a measure of the breadth of water content over which the soil behaves plastically. For hydraulic barrier materials, the soil must have adequate plasticity; otherwise, the material will be too deficient in clay to serve as an adequate hydraulic barrier. For drainage materials, the soil must be free of clay—drainage materials typically have little or no plas-

ticity. By measuring the plasticity of a soil, Atterberg limits provide a rapid and convenient means for assessing its suitability for its intended purpose.

The Atterberg limits of a soil are measured in the laboratory. Samples for testing can be taken from the borrow area or from the final construction area. Experienced field engineers and technicians can often tell just from examining and handling the soil whether it has the appropriate Atterberg limits. With questionable soils, or soils that are variable in the borrow area, it is helpful to sample the borrow soils on a close grid of test pads and wait for the test results before proceeding with further soil processing or placement.

##### *Percentage of Fines*

The percentage of fine-grained material in a soil is defined as the percentage on a dry-weight basis of soil that will pass through the openings of a No. 200 sieve, which are 0.075 mm (0.003 in.) wide. Material retained on the No. 200 sieve is defined as the coarse-grained fraction and material that will pass through the openings is the fine-grained fraction. The percentage of fines may be measured with ASTM Method D422 or D1140, with sample preparation performed with Method D2217, if necessary.

As with Atterberg limits, an experienced engineer or technician can often tell by visual observation whether the soil has an adequate amount of fines (barrier materials). In such cases, the QC tests serve primarily to build a formal record of test results that verifies the observations made by the field personnel. With sandy drainage materials, it is usually difficult to determine by visual observation alone whether the material has an excessive amount of fines.

##### *Percentage of Gravel*

The soil for barrier materials cannot contain an excessively large percentage of gravel. The gravel fraction is determined by sieving the soil through a No. 4 sieve, which has 4.76-mm (0.19-in.) wide openings. Sieving of soil to determine the percentage of gravel is performed with ASTM Method D422, a method similar to the test for percentage fines. All material that will not pass through the openings is defined as gravel, according to the Unified Soil Classification System (ASTM Standard Prac-

tice D2487) (Note Sieve analysis via ASTM Method D422 is one of several tests used for soil classification via the procedure for interpretation of test data given in Standard Practice D2487 Also, particles larger than 75 mm [3 in.] are cobbles.)

### Maximum Size of Particles or Clods

For barrier materials, the maximum size of stones in the clayey soil cannot be too large. However, it is impractical for field personnel to sieve large, representative samples of soil to determine the largest particle size. In the field, the problem is probably an occasional oversized stone, which no formal sampling procedure is likely to detect. Rather, observations by CQA personnel provide the best opportunity to detect excessively large stones.

On occasion, the maximum size of soil clods may be specified in the construction specifications. Again, sieving wet, clayey soils to determine the clod size distribution is impractical. Direct measurement of representative clods by field personnel is probably the simplest and best way to verify that the clods are not too large.

### Requirements for Field Personnel

On large and important projects, where CQA is considered crucial to the overall success, a full-time inspection of soil excavation in the borrow area and continuous classification of excavated soils are recommended. Soils are variable materials, and the borrow area offers the best opportunity to detect the presence of unsuitable materials.

### Frequency of Testing

Table 6-1 summarizes the frequency of testing recommended by Daniel (2). These recommendations are based primarily upon practices reported by Gordon, Huebner, and Kmet (3) and reiterated by Goldman et al. (4) for clay liners. Although the recommendations are intended for low hydraulic conductivity liners, they are useful for other soil materials, as well. Experience has shown that even more frequent testing is helpful during the initial phases of construction, because this is the period when problems are most likely to occur.

## CONTROL OF SUBGRADE PREPARATION

The subgrade must be properly prepared and compacted before any component of the cover system that requires significant compaction can be placed. Typically, the low hydraulic conductivity soil barrier requires compaction with heavy equipment, whereas the compaction of other layers is much less important. Thus, CQA for subgrade preparation is critical for the low hydraulic conductivity component of a cover system but may not be necessary for other components.

Table 6-2 summarizes the recommended tests for subgrade preparation. For low hydraulic conductivity soils, the surface of a previously compacted layer of soil should be disked ("scarified") prior to placing a new layer of soil.

**Table 6-1. Recommended Materials Tests for Barrier Layers (2)**

Parameter	Test Method	Minimum Testing Frequency
Percent Fines (1)	ASTM D1140	1 per 1,000 yd <sup>3</sup> (2)(3)
Percent Gravel (4)	ASTM D422	1 per 1,000 yd <sup>3</sup> (2)(3)
Liquid & Plastic Limits	ASTM D4318	1 per 1,000 yd <sup>3</sup> (2)(3)
Water Content	ASTM D4643(5)	1 per 200 yd <sup>3</sup> (2)(6)
Water Content (7)	ASTM D2216	1 per 1,000 yd <sup>3</sup> (7)(3)
Construction Oversight	Observation	Continuous in borrow pit on major projects; continuous in placement area on smaller projects

#### Notes:

1. Percent fines is defined as percent passing the No. 200 sieve.
2. In addition, at least one test should be performed each that soil is excavated or placed, and additional tests should be performed on any suspect material observed by QA personnel.
3. 1,000 yd<sup>3</sup> = 836 m<sup>3</sup>.
4. Percent gravel is defined as percent retained on the No. 4 sieve.
5. This is a microwave oven drying method. Other methods may be used, if more appropriate. Any method used besides direct drying via ASTM D2216 should be calibrated against ASTM D2216 for the onsite solids.
6. 200 yd<sup>3</sup> = 167 m<sup>3</sup>.
7. Microwave oven drying and other rapid measurement methods may involve systematic errors. Conventional oven drying (ASTM D2216) is recommended on every fifth sample taken for rapid measurement. The intent is to document any systematic error in rapid water content measurement.

Requirements for scarification should be set forth in the construction specification. The scarification should be observed to ensure that the newly placed layer blends in with the previously compacted layer.

## SOIL PLACEMENT

Soils are placed in layers called lifts. The thickness of a lift is typically specified in the construction documents. For materials having low hydraulic conductivity, the thickness of a lift should not exceed the specified value. Otherwise, the lower portion of the lift may be inadequately compacted, the bonding of lifts is likely to be poor, and the hydraulic conductivity could be larger than desired. Control of lift thickness is critical for low-hydraulic-conductivity, compacted soil liners. The loose lift thickness can be checked visually near the edge of a lift. The exact thickness of a loose lift can be measured by digging a hole in the soil.

**Table 6-2. Recommended Tests and Observations on Subgrade Preparation (2)**

Parameter	Test Method	Minimum Testing Frequency
Percent Compaction (1)	ASTM D2922 or ASTM D1556 or ASTM D2937 or ASTM D2167	1 per acre (2)
Compaction Curve	ASTM D698 (3)	1 per 5 acres
Preparation of Previously Compacted Lift	Observation	Full coverage

**Notes:**

1. Percent compaction is defined as the dry density of the compacted soil divided by the maximum dry density measured in the laboratory with a specified method of compaction. The test methods listed are for measurement of the dry density of the compacted soil.
2. In addition, at least one test should be performed each day the construction personnel prepare subgrade by compaction.
3. Other laboratory compaction methodologies are often employed.
4. 1 acre = 0.4 ha.

Fill elevations are usually controlled with grade stakes or lasers; laser equipment is not currently in widespread use. If grade stakes are used, care must be taken to remove them and repair the resulting holes. The CQA inspector should make sure that grade stakes are not buried in the cover system. To accomplish this, an inventory system in which all grade stakes are numbered and accounted for each day is recommended. One advantage of ferrous metal grade stakes is that if inadvertently buried in the cover system, they can be found with a metal detector. The holes left by grade stakes should be packed with soil liner material or bentonite tamped into the hole in layers with a rod.

**SOIL COMPACTION**

**Drainage Layers**

Nominal compaction of drainage layers is usually adequate. Rarely is it necessary to control the degree of compaction of drainage materials. One potential problem to avoid is "bulking" of wet or damp sands; compaction in lifts will overcome such problems.

Of greater importance than the degree of compaction is protecting drainage materials from contamination by fines. Over-compaction of the drainage materials can grind up soil and increase the amount of fines. However, the specifications should not permit use of nondurable materials that are easily broken down. Field personnel should observe the amount of fines before and after compaction. If there is any question about grinding of the soil during compaction, the percentage of fines should be

measured after compaction to confirm that the compaction process has not increased the percentage of fines.

**Barrier Materials**

Quality control of barrier materials usually focuses heavily on water content and dry unit weight. A typical construction specification might require that the soil be compacted over a specified range of water content (e.g., 0 to 4 percent wet of optimum) to a minimum dry unit weight (e.g., 95 percent of the maximum dry unit weight from standard Proctor compaction).

The methodology for determining the appropriate compaction criteria for CQA has recently been reviewed by Daniel and Benson (5). Figure 6-1 shows the form of a typical compaction specification. The "Acceptable Zone" is based upon a specified range of water content and a minimum dry unit weight. The zero air voids curve represents a theoretical upper limit above which points cannot exist. Figure 6-1 represents the usual format for specifying the compaction requirements for a barrier layer. However, as indicated by Daniel and Benson, the usual format represents historical practice for structural fills and is not necessarily appropriate for low hydraulic conductivity soil liner or cover systems. The next several graphs illustrate the problem with the usual form of specification.

Figure 6-2 contains a compaction curve and a plot of hydraulic conductivity versus molding water content for three compactive energies. The water content-dry unit weight points are replotted in Figure 6-3 with solid symbols used for those compacted specimens that had hydraulic conductivities less than or equal to  $1 \times 10^{-7}$  cm/s and open symbols for specimens with a hydraulic conductivity greater than  $1 \times 10^{-7}$  cm/s. The Acceptable Zone, which encompasses the compacted specimens with low hydraulic conductivity, has a much different shape from the one shown in Figure 6-1. Figure 6-4 presents contours of values of water content and dry unit weight that yielded certain hydraulic conductivities for one particular soil. Also shown in Figure 6-4 is a modified Proctor compaction curve and a typical specification that might be written using the procedure suggested in Figure 6-1. In this case, a portion of the typical Acceptable Zone contains soils with unacceptably large hydraulic conductivities. Use of the Acceptable Zone in Figure 6-4 based on typical construction practice, i.e., the practice sketched in Figure 6-1, does not ensure that the compacted soils have low hydraulic conductivity.

The recommended procedure for defining a suitable range of water content and dry unit weight is shown in Figure 6-5. The procedure involves four steps:

1. The soil is compacted with three compactive energies that span the range of compactive effort expected in the field. The three energies recommended by Daniel and Benson (5) are modified Proctor, standard Proctor, and reduced Proctor. Reduced

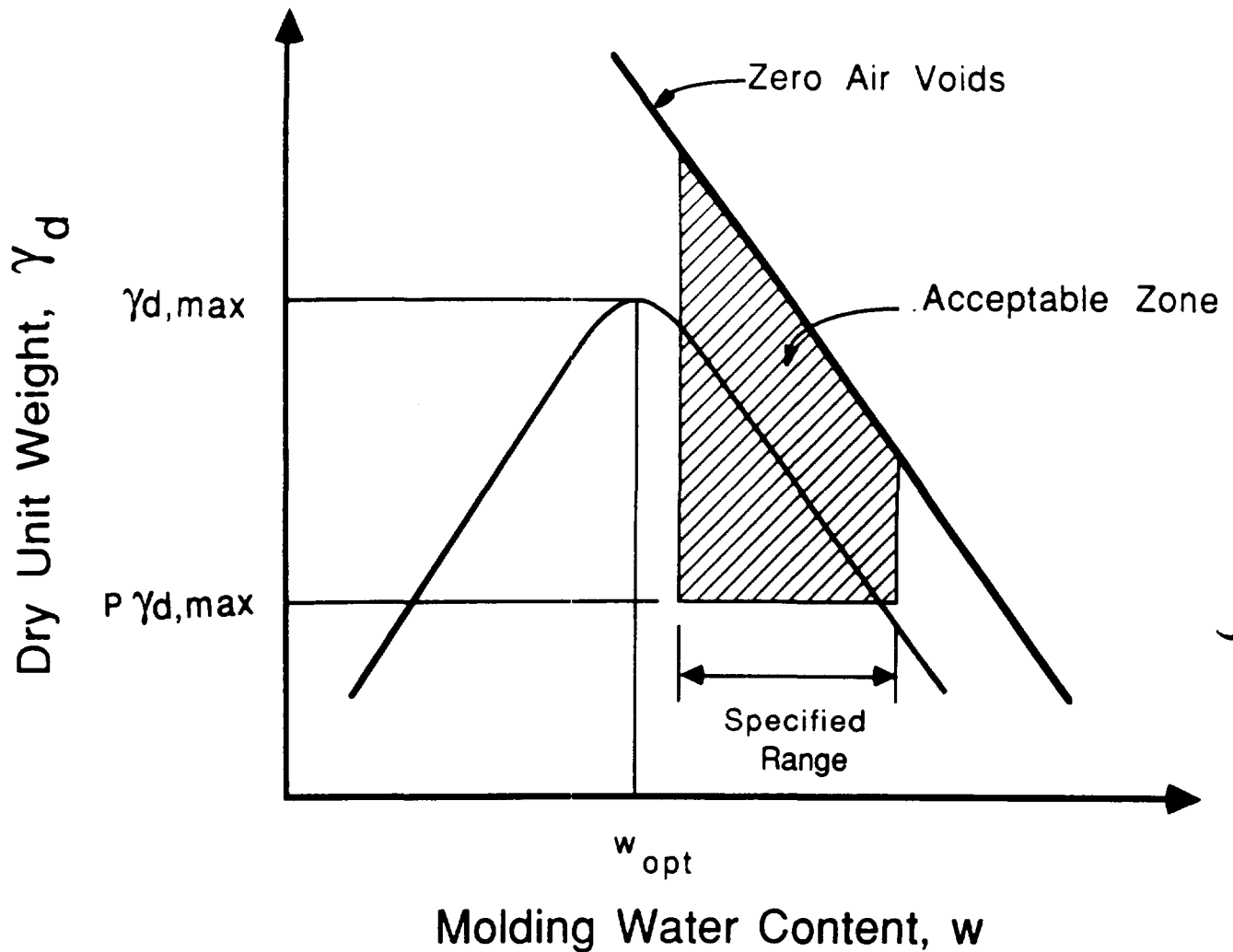

Figure 6-1. Traditional method for specification of acceptable water contents and dry unit weights (5).

2. The specimens are permeated and the hydraulic conductivity of each specimen is determined. Hopefully, at least some of the test specimens will have hydraulic conductivities that are less than the design maximum value. Care should be taken to make sure that the conditions of permeation appropriately simulate field conditions. For cover systems, it is particularly important that the confining stress used in the laboratory tests is not significantly larger than the value expected in the field (which is usually small for cover systems).
3. The water content-dry unit weight points are replotted, and an Acceptable Zone is drawn. Some judgment may be necessary in drawing the Acceptable Zone.
4. The final step is to modify the Acceptable Zone in any appropriate manner to take into account of variables besides hydraulic conductivity, e.g., susceptibility to desiccation damage, local construction practices, or shear strength considerations. When the Acceptable Zone is modified, it is only made smaller, not larger. Figure 6-6 illustrates how one might combine an Acceptable Zone based on hydraulic conductivity with one based upon shear strength to develop a single, overall Acceptable Zone.

The lower limit of the Acceptable Zone will probably be parallel to a line of constant degree of saturation or to the line of optimums (Figure 6-7). (The line of optimums is a curve that connects points of maximum dry unit weight and optimum water content measured with different energies of compaction.) It may be possible to use a constant degree of saturation or a line parallel to the line of optimums for the lower limit of the Acceptable Zone.

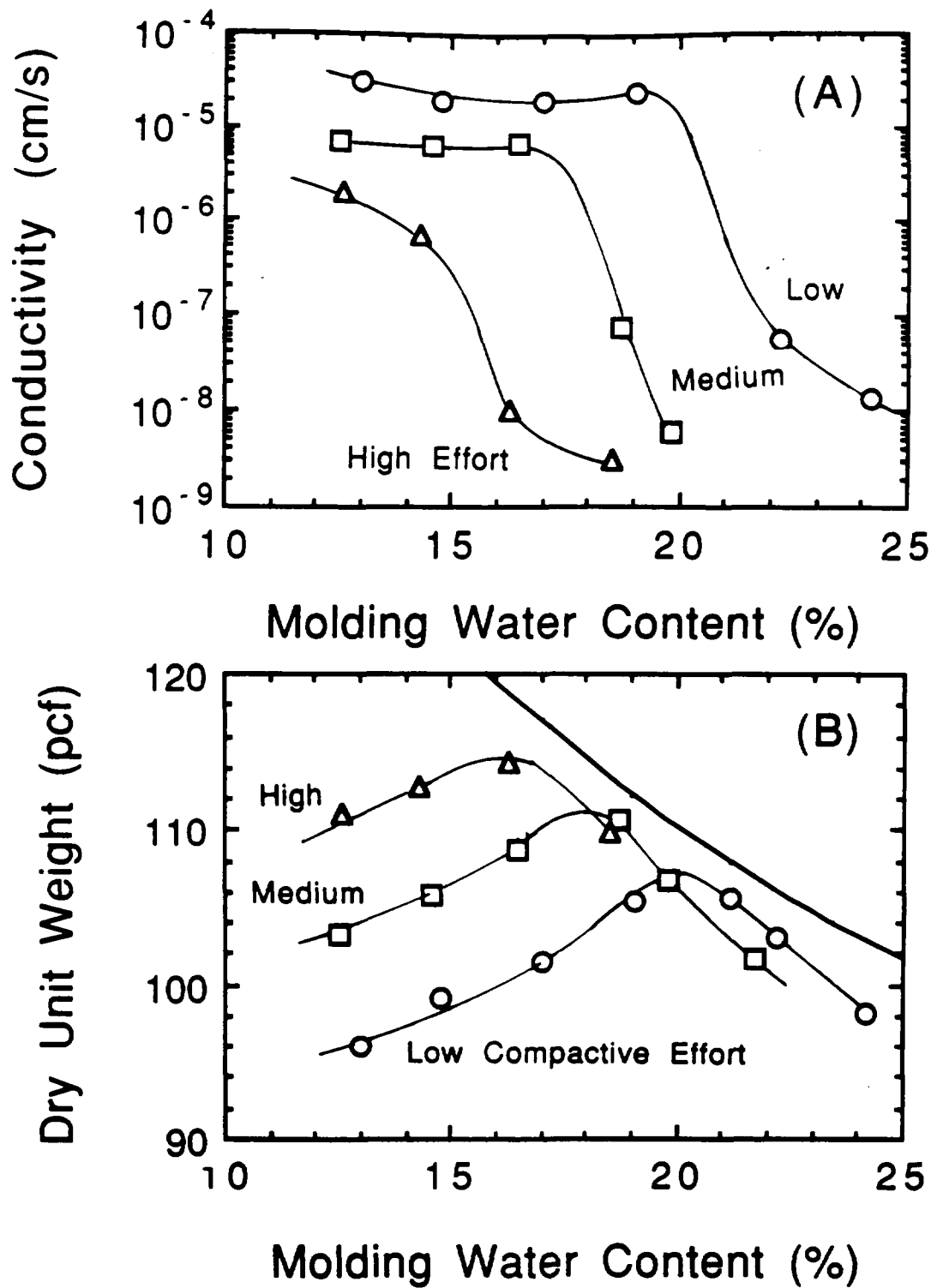

Figure 6-2. Data from Mitchell et al. for silty clay compacted with impact compaction (6).

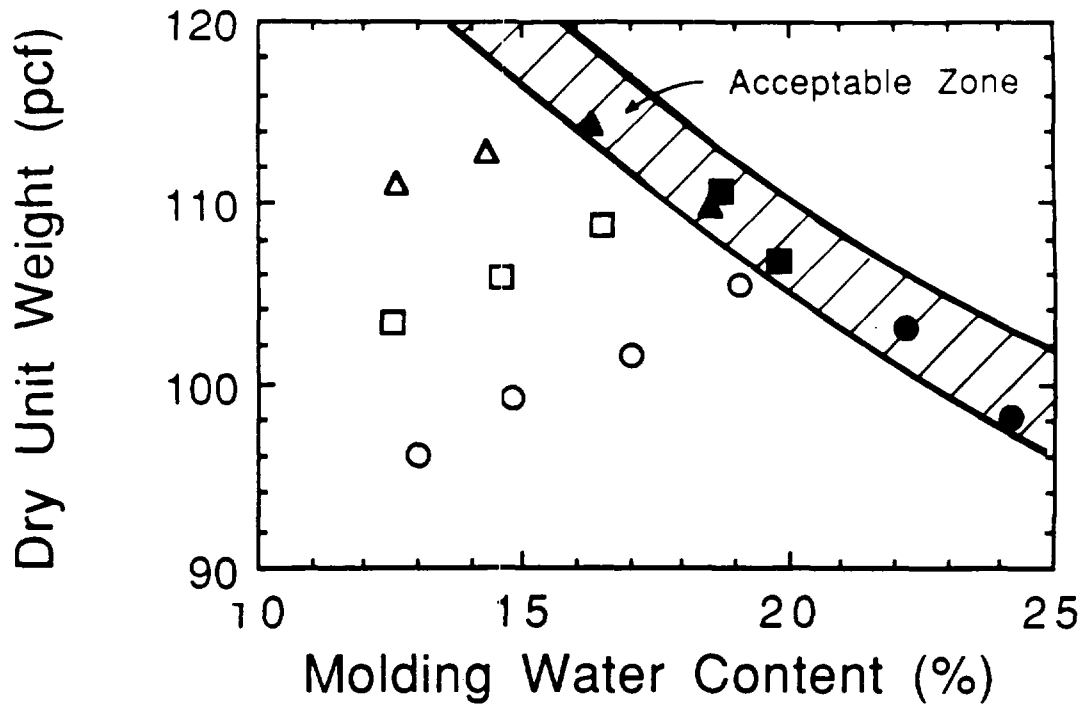

Figure 6-3. Compaction data for silty clay (6); solid symbols represent specimens with hydraulic conductivity less than or equal to  $1 \times 10^{-7}$  cm/s and open symbols represent specimens with hydraulic conductivity  $> 1 \times 10^{-7}$  cm/s.

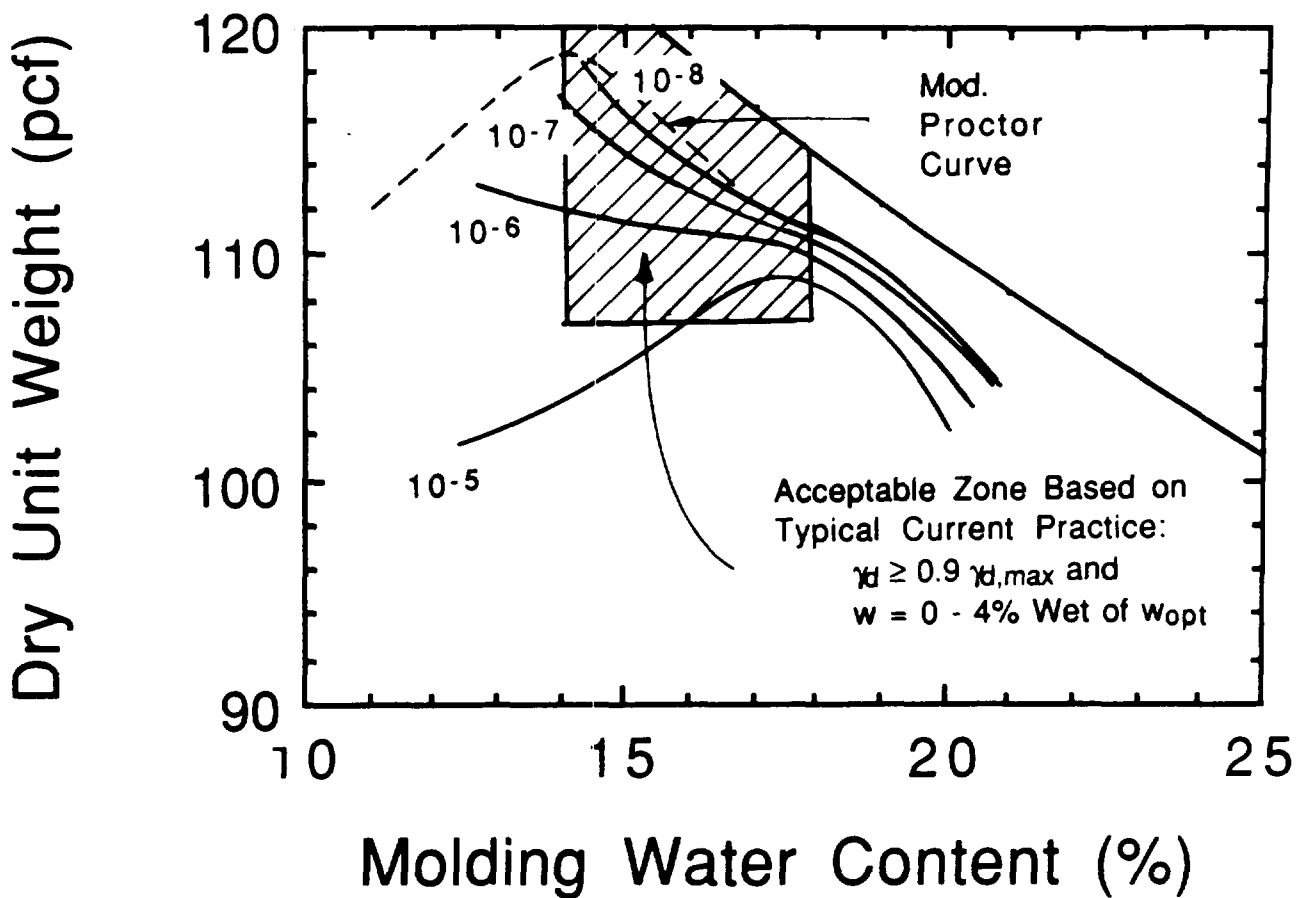
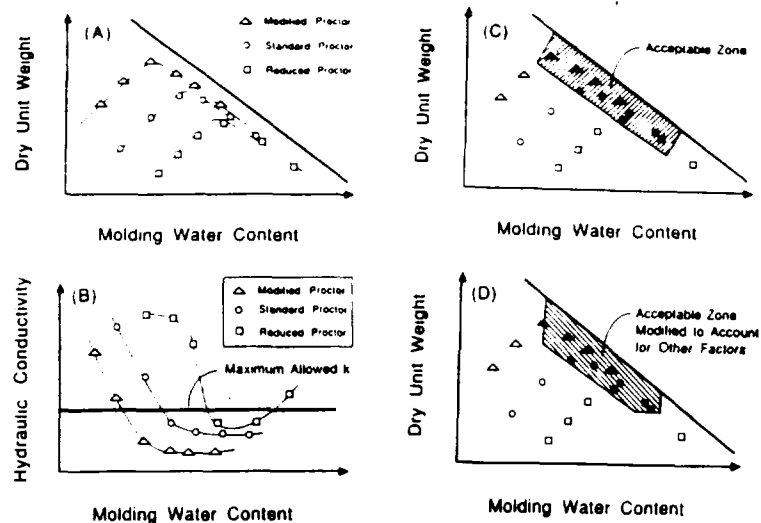

Figure 6-4. Contours of constant hydraulic conductivity for silty clay compacted with kneading compaction (6).



- (A) Determine compaction curves with three compactive efforts  
 (B) Determine hydraulic conductivity of compacted specimens  
 (C) Replot compaction curves using solid symbols for samples with adequately low hydraulic conductivity and open symbols for samples with a hydraulic conductivity that is too large  
 (D) Modify Acceptable Zone based on other considerations such as shear strength or local construction practices

Figure 6-5. Recommended procedure.

The water content of the soil at the time the soil is compacted has a significant impact on almost all engineering properties of the soil. For instance, compaction of the soil at a low water content leads to a strong, low-compressibility soil that is not as vulnerable to desiccation cracking as wetter soils. However, dry soils are brittle and crack easily, e.g., if there is differential settlement of the underlying waste. Soils compacted at high water contents are softer, more compressible, and more vulnerable to damage from desiccation. Wet soils, however, are ductile and can accommodate more differential settlement without cracking than dry soils can. The water content range specified for construction should reflect a careful consideration of these, and possibly other, variables. It is critical that the CQA program ensure that the soil is compacted to the proper water content.

The procedure summarized in Figure 6-5 was applied to a cover system constructed at the Oak Ridge Y-12 Operations as described by Daniel and Benson (5). The compaction curves for one of the two types of soils (called Type A soils) are shown in Figure 6-8. Hydraulic conductivities are plotted in Figure 6-9. For this project, the design called for compaction of the soil to achieve a hydraulic conductivity of  $1 \times 10^{-7}$  cm/s or less. The Acceptable Zone, shown in Figure 6-10, shows the range of water content and dry unit weight that met this requirement. In the field, technicians measured the water content and dry unit weight, checked to see if the point plotted within the Acceptable Zone, and made a pass-fail decision based on whether the point was within or outside of the Acceptable Zone. If the point was outside the

Acceptable Zone, either the soil was compacted more or the soil was removed, reprocessed, and recompact.

For soil bentonite mixes, the following procedure is recommended:

1. Mix batches of soil at different bentonite contents, e.g., 0, 2, 4, 6, 8, 10, and 15 percent bentonite (dry weight basis).
2. Develop standard Proctor compaction curves for each bentonite content.
3. Compact samples with standard Proctor procedures at a water content 2 percent wet of optimum for each bentonite content.
4. Permeate the soils prepared in Step 3 and develop a plot of hydraulic conductivity versus bentonite content.
5. Decide how much bentonite to use based on data from Step 4, taking into account construction variability. Usually more bentonite is used than Step 4 indicates is necessary, because, in the field, the bentonite will not always be mixed as uniformly with the soil as it was in the laboratory.
6. For the average bentonite content expected in the field, utilize the procedures described earlier and summarized in Figure 6-5.

The procedures discussed in the preceding pages for determining an appropriate range of water content and dry unit weight involve laboratory tests. The compaction

**Table 6-3. Recommended Tests and Observations on Compacted Soil for Barrier Layers (2)**

Parameter	Test Method	Minimum Testing Frequency
Water Content (1)	ASTM D3017 or ASTM D4643	5/acre/lift (2)
Water Content (3)	ASTM D2216	1/acre/lift (3)
Density (4)	ASTM D2922 or ASTM D2937	5/acre/lift (2)
Density (Note 5)	D1556	1/acre/lift (5)
Number of Passes	Observation	1/acre/lift (2)
Construction Oversight	Observation	Continuous

**Notes:**

1. ASTM D3017 is a nuclear method and D4643 is microwave oven drying. Direct water content determination (ASTM D2216) is the standard against which nuclear, microwave, or other methods of measurements are calibrated for onsite soils.
2. In addition, at least one test should be performed each day soil is compacted, and additional tests should be performed in areas for which QA personnel have reason to suspect inadequate compaction.
3. Every fifth sample tested with ASTM D3017 or D4643 also should be tested by direct oven drying (ASTM D2216) to aid in identifying any significant, systematic calibration errors with D3017 or D4643.
4. ASTM D2922 is a nuclear method and D2937 is a drive ring method. These methods, if used, should be calibrated against the sand cone (ASTM D1556). Alternatively, the sand cone method can be used directly.
5. Every fifth sample tested with D2922 or D2937 also should be tested (as close as possible to the same test location) with the sand cone (ASTM D1556) to aid in identifying any systematic calibration errors with D2922 or D2937. The sand cone method may be used in lieu of D2922 and D2937.
6. 1 acre = 0.4 ha.

procedures used in the laboratory should simulate field compaction as closely as possible. There is always a possibility, however, that field construction will produce macro-scale features (e.g., poor bonding between lifts) that cannot be duplicated with laboratory compaction. Large-scale in situ hydraulic conductivity testing of field-compacted soil is recommended for a test pad; the purpose of such tests is to verify that hydraulic conductivity objectives can be met on the field scale. Test pads are discussed further later in this chapter.

Table 6-3 lists the tests and observations recommended for ensuring that the soil is properly compacted. Gordon et al. provides the basis for the recommended frequency

of testing (3). Periodic calibration checks are recommended for tests that are performed with microwave ovens, nuclear devices, drive rings, or other equipment that may introduce a small, systematic bias in the test results. Systematic measurement errors, especially for water content, must be documented.

In Table 6-3, it is recommended that observations of the number of passes of the compaction equipment be periodically determined. The compactive energy delivered to low hydraulic conductivity materials has a large influence on the hydraulic conductivity of the materials after compaction. If too little compactive energy is delivered to the soil, e.g., because too few passes of the compactor are made over the soil, then the hydraulic conductivity may not be as low as desired.

Some individuals place great emphasis on hydraulic conductivity tests performed on "undisturbed" samples taken from a compacted lift of low hydraulic conductivity material. One sampling procedure is to push a thin-walled sampling tube (sometimes called a "Shelby tube") into the soil with a backhoe, as shown in Figure 6-12. However, with this procedure, the sampling tube usually rotates during the push (Figure 6-12), which leads to unacceptable disturbance of the soil sample. This sampling procedure is strongly discouraged. A better procedure is to use a thin-walled sampling tube that is only about 23 cm (9 in.) long. (The tube should never be pushed more than about 23 cm [9 in.] into the soil because stiff, compacted soils usually plug the sampling tube if a longer push is used.) As shown in Figure 6-13, a hydraulic jack is placed on top of a sampling tube. The jack is used to push the sampling tube straight into the soil. A backhoe can be used, but only as a reaction for the hydraulic jack as shown in Figure 6-14. Sampling procedures described in ASTM Practice D1587 should be followed. Procedures for preserving and transporting samples should be in accord with ASTM Practice D4220.

There are several potential problems with laboratory hydraulic conductivity tests performed on "undisturbed" samples of the liner material for CQA purposes:

- If there are any rocks or stones in the soil, it may be difficult or impossible to obtain a representative sample for testing. When stones are present, the sampling tube drags the stones through part of the soil sample, which damages the sample. Many samples may have to be taken and discarded before a sample that does not contain too many stones is obtained. However, the value of testing a sample that contains almost no stones, when most of the soil does contain stones, is questionable.
- Small samples of soil may not be representative. If there are cracks, zones of poor compaction, or other hydraulic defects, the chances that an occasional small sample will detect those defects are remote. Just because laboratory hydraulic conductivities are low

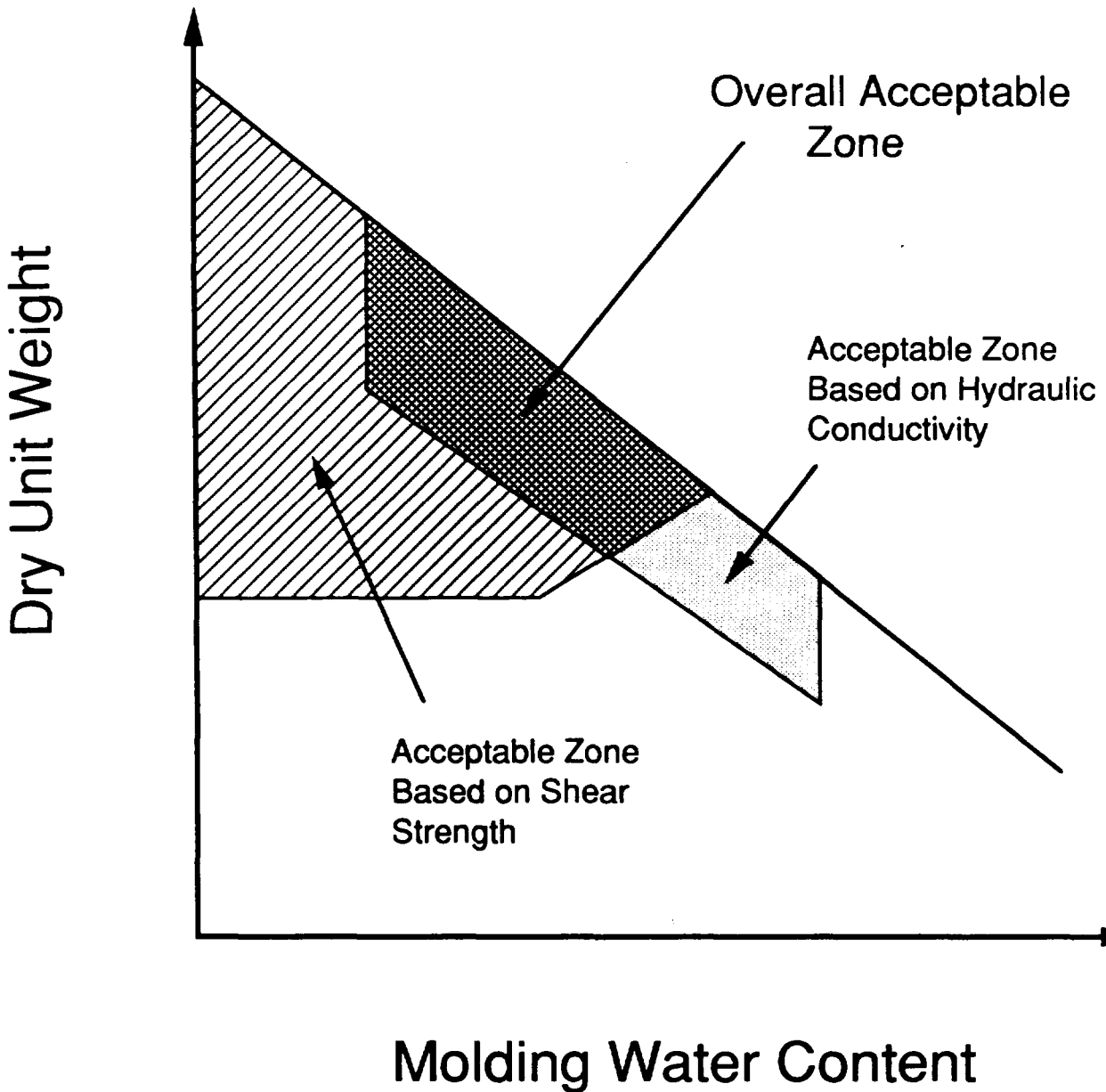

Figure 6-6. Use of hydraulic conductivity and shear strength data to define a single, overall acceptable zone (5).

does not necessarily mean that the field values are also low.

- Laboratory hydraulic conductivity tests take from 1 day to 1 week to complete. The value of this type of test for CQ purposes is minimized by the long time required to obtain results. If the completed lift is left exposed while the CQA team awaits the results of hydraulic conductivity tests, the whole process may be counterproductive.

There is no widespread agreement about how CQA officials should deal with the problems noted above for laboratory hydraulic conductivity tests. The problems are noted for the reader's information, and it is hoped that

CQA planners will develop strategies for dealing with these difficulties.

Finally, any holes made in the soil must be sealed. Quality assurance personnel should visually inspect the sealing of some of the holes made for QC testing.

#### PROTECTION OF A COMPLETED LIFT

Visual observations are recommended to determine if adequate measures have been taken to protect each lift of soil from desiccation, freezing, or other damaging forces. Additional tests, e.g., water content tests, should be required if there is any question that the soil may have been damaged after compaction.

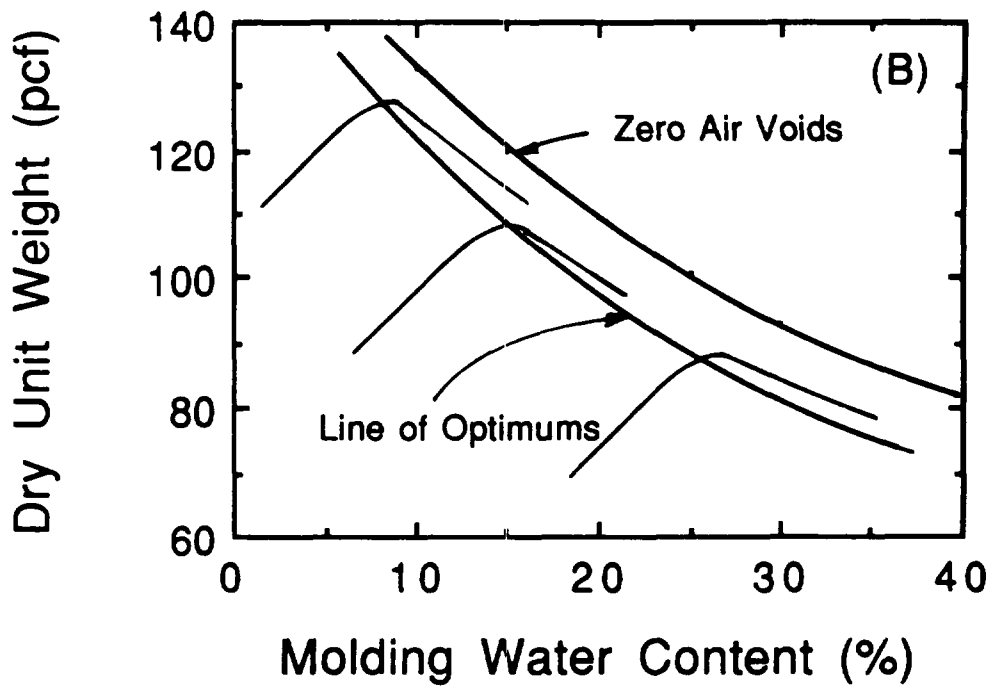
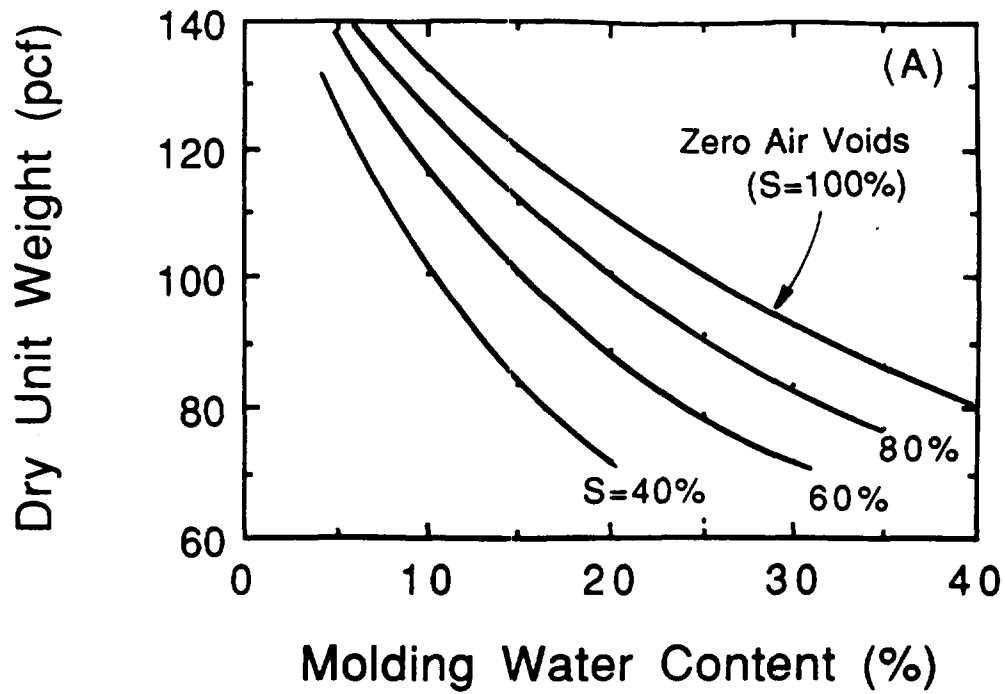

Figure 6-7. Possible approaches for specifying lower limit of Acceptable Zone: (A) minimum degree of saturation, S; and (B) line of optimums (5).

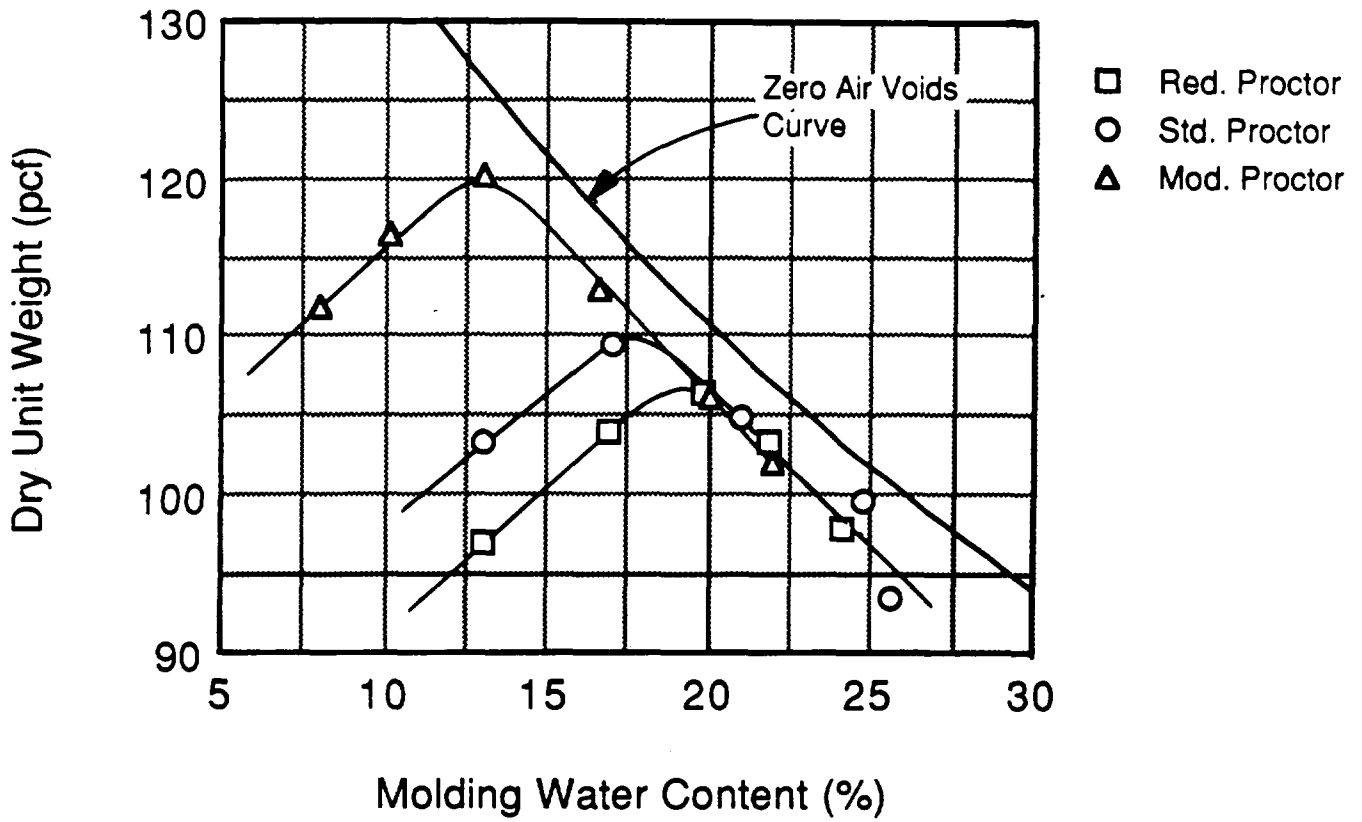

Figure 6-8. Compaction curves for Type A soil from East Borrow area at Oak Ridge Y-12 operations project (5).

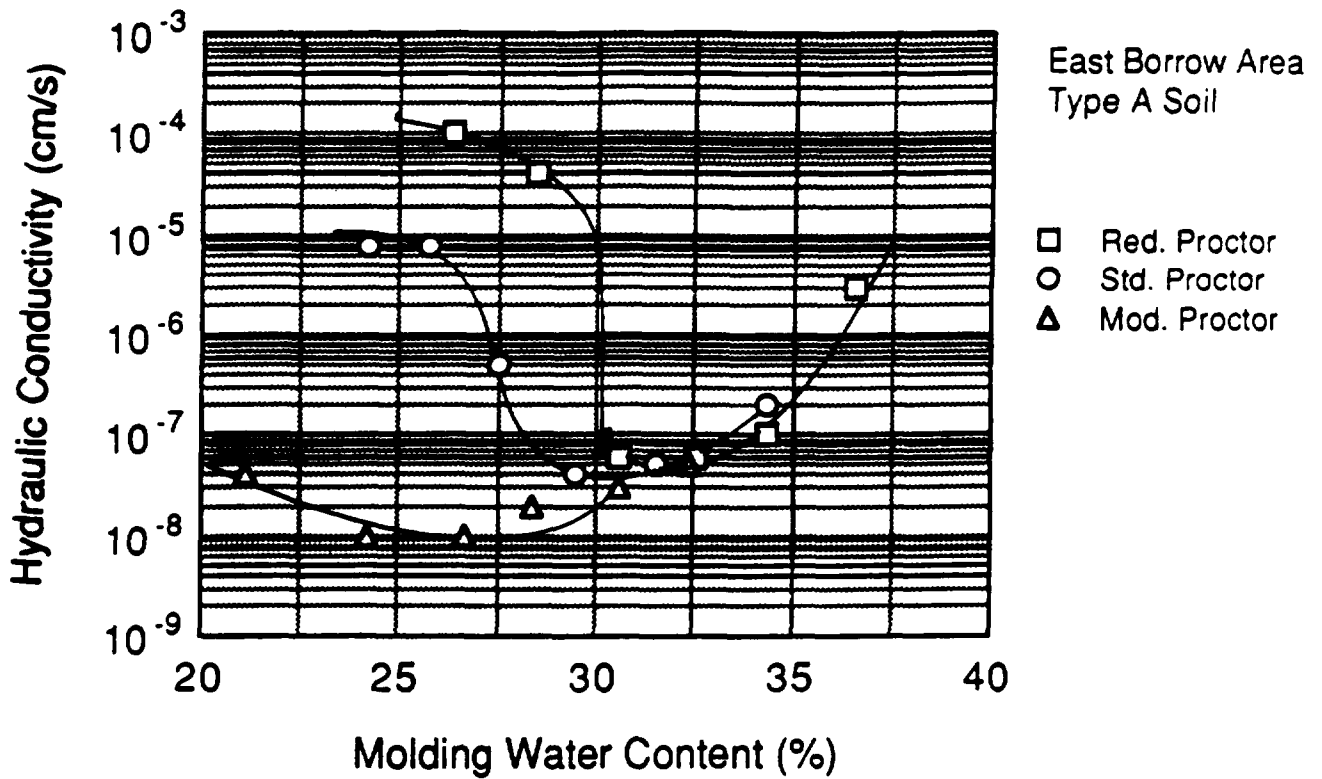

Figure 6-9. Hydraulic conductivity versus molding water content for Type A soil from East Borrow area at Oak Ridge Y-12 operations project (5).

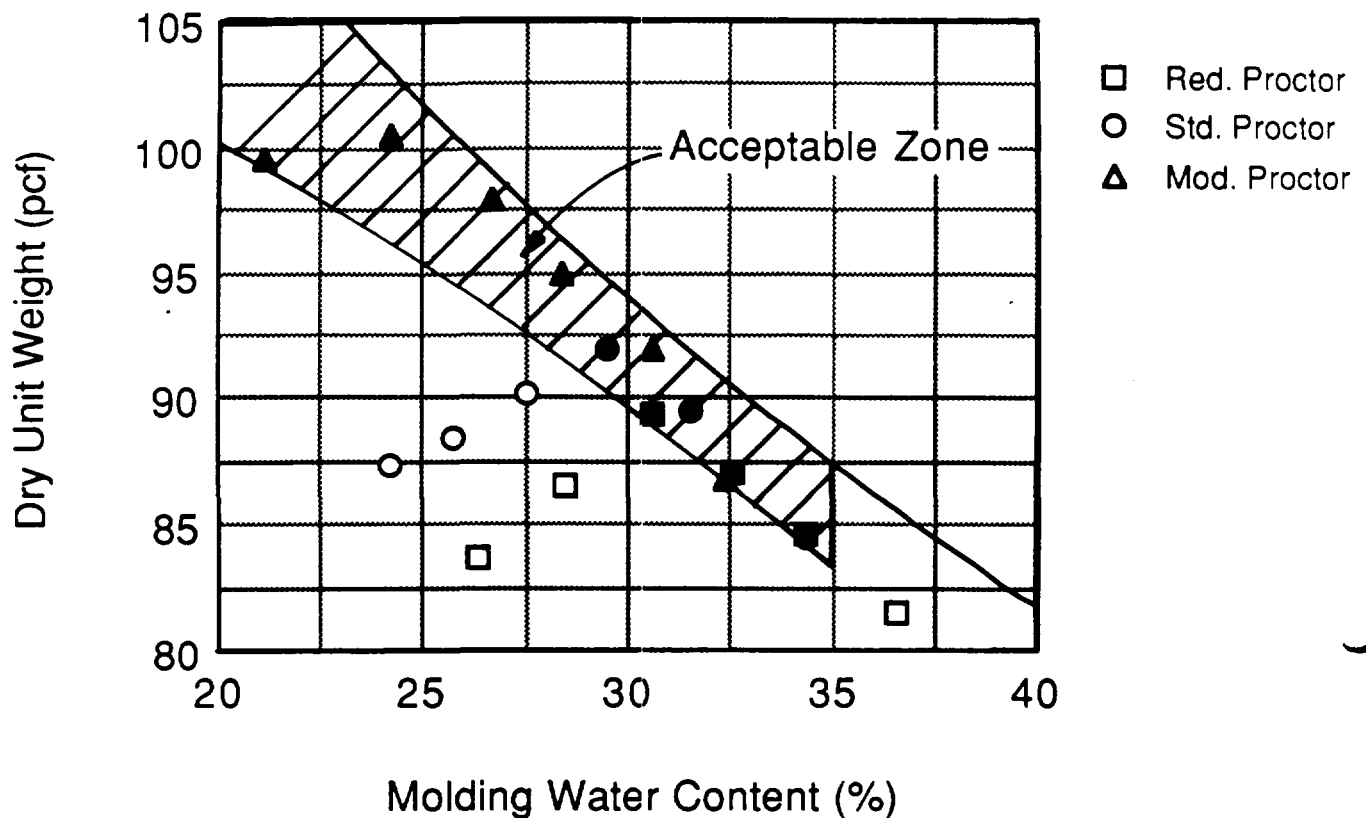

Figure 6-10. Acceptable zone for Type A soil from East Borrow area at Oak Ridge Y-12 operations project (5).

### SAMPLING PATTERN

The CQA plan should detail the procedures for selecting locations where samples will be taken. A random pattern, or a sampling pattern utilizing a grid system, is recommended. However, the CQA personnel should have the authority to request additional tests at any questionable location.

### TEST PADS

Occasionally, test pads are constructed for the purpose of verifying that materials and methods of compaction will achieve the desired results, e.g., low in-field hydraulic conductivity. If a test pad yields adequate results, the CQA team should utilize the test pad in the CQA program. One of the purposes of QC testing and QA observations should be to ensure that the actual cover is built to standards that equal or exceed those used in building the test pad.

If a test pad is built, it may be desirable to have a procedural construction specification. The test pad is used to demonstrate that the construction procedure is appropriate. If the construction procedure is specified, a critical objective of the CQA program should be to make an adequate number of observations to verify that the specified procedure has been followed.

One or more in situ hydraulic conductivity tests are usually performed on the test pad. Testing procedures are discussed by Daniel (7) and Sai and Anderson (8). The most widely used method of measurement is the sealed double ring infiltrometer (SDRI). Testing procedures for the SDRI are given in ASTM Method D5093. A bevy of other tests (water content, dry unit weight, Atterberg limits, etc.) is usually part of the testing protocol, as well, to provide full documentation of the test pad.

### OUTLIERS

Soils are variable materials. It is inevitable that the soil materials will fail to meet specifications at some points in the soil mass. If all QC tests pass, this does not mean that the soil everywhere meets the project specifications; it just means that enough tests were not performed to locate the occasional outlier.

Occasional outliers are not necessarily harmful. For barrier layers, the soils are constructed in multiple lifts in part as a result of recognition that soils are variable and that the compaction process is not perfect. For drainage layers, occasional pockets of low hydraulic conductivity materials will not harm the performance of reasonably thick drainage layers—permeating fluids will simply go around the low hydraulic conductivity material.



**Figure 6-11. Pushing of thin-walled sampling tube with a backhoe.**



**Figure 6-12. Tilting of sampling tube during push.**



Figure 6-13. Placement of hydraulic jack on top of sampling tube.



Figure 6-14. Use of backhoe as a reaction for hydraulic jack.

At least two approaches may be utilized for dealing with outliers:

- The usual procedure is not to allow any outliers. However, for the reasons noted above, this approach is not realistic and frequently causes some manipulation of tests or test results to ensure that unrealistic specifications are met. In addition, the CQA team at the end of the project may be left trying to justify the insignificance of the occasional outlier (after the construction is complete).
- One possible solution is to permit an occasional outlier. Usually, if a small percentage of tests fail, the effect of the outliers is nil. Such a specification is more realistic and tends to discourage manipulation of sampling locations, tests, or test results to meet unrealistic specifications.

If a test does fail and it is believed that the failure represents inadequate materials or inadequate construction procedures, the extent of the failed area must be defined and the area must be repaired. The specifications should prescribe how the area to be repaired will be determined.

### SUMMARY

Figure 6-15 is a checklist of critical parameters for low hydraulic conductivity barrier materials. A checklist for drainage materials is shown in Figure 6-16. The items shown on these checklists are intended to ensure that the materials of construction are adequate and that appropriate methods of construction have been utilized. The CQA process involves a combination of QC testing and observation by qualified personnel.

### REFERENCES

1. U.S. EPA. 1986. Technical guidance document: construction quality assurance for hazardous waste land disposal facilities. Office of Solid Waste and Emergency Response, Washington, DC, EPA/530-SW-86-031.
2. Daniel, D.E. 1990. Summary review of construction quality control for compacted soil liners. In: R. Bonaparte, ed. *Proceedings, Waste Containment Systems: Construction, Regulation, and Performance*. New York: American Society of Civil Engineers, pp. 175-189.
3. Gordon, M.E., P.M. Huebner, and P. Kmet. 1984. An evaluation of the performance of four clay-lined landfills in Wisconsin. In: *Proceedings, Seventh Annual Madison Waste Conference on Municipal and Industrial Waste*, Madison, WI. pp. 399-460.
4. U.S. EPA. 1988. Design, construction, and evaluation of clay liners for waste management facilities. Washington, DC. EPA/530/SW-86/007F.
5. Daniel, D.E. and C.H. Benson. 1990. Water content-density criteria for compacted soil liners. *Journal of Geotechnical Engineering*, Vol. 116, No. 12, pp. 1811-1830.
6. Mitchell, J.K., D.R. Hooper, and R.G. Campanella. 1965. Permeability of compacted clay. *Journal of the Soil Mechanics and Foundations Division ASCE*, Vol. 91, No. 4, pp. 41-65.
7. Daniel, D.E. 1989. In situ hydraulic conductivity tests for compacted clay. *Journal of Geotechnical Engineering*. Vol. 115, No. 9, 1205-1226.
8. Sai, J.O. and D.C. Anderson. 1990. Field hydraulic conductivity tests for compacted soil liners. *Geotechnical Testing Journal*. Vol. 13, No. 3, pp. 215-225.

**CRITICAL VARIABLES FOR LOW HYDRAULIC CONDUCTIVITY LAYER**

**Material:**

- Minimum Liquid Limit = \_\_\_\_\_
- Minimum Plasticity Index = \_\_\_\_\_
- Maximum Particle Size = \_\_\_\_\_
- Maximum Percentage of Gravel = \_\_\_\_\_
- Minimum Percentage of Fines = \_\_\_\_\_
- Water Content/Density Defined (Y/N) \_\_\_\_\_
- Maximum Clod Size = \_\_\_\_\_

**Lifts:**

- Scarify Surface Before Placing (Y/N) \_\_\_\_\_
- Maximum Loose Lift Thickness = \_\_\_\_\_
- Maximum Completed Lift Thickness = \_\_\_\_\_

**Compactor:**

- Minimum Weight = \_\_\_\_\_
- Type of Roller Drum \_\_\_\_\_

**Compaction:**

- Minimum Number of Passes = \_\_\_\_\_

**Protection:**

- Protection from Dessication & Freezing (Y/N) \_\_\_\_\_

Figure 6-15. Checklist of critical variables for CQA of low hydraulic conductivity compacted soil used in a cover system.

---

**CRITICAL VARIABLES FOR DRAINAGE LAYER**

Material:

Maximum Percentage of Fines = \_\_\_\_\_

Maximum Particle Size = \_\_\_\_\_

Lifts:

Maximum Loose Lift Thickness = \_\_\_\_\_

Compactor:

Maximum Weight = \_\_\_\_\_

Type of Roller Drum \_\_\_\_\_

Compaction:

Desirable Number of Passes = \_\_\_\_\_

Grinding of Soil:

Visual Inspection? (Y/N) \_\_\_\_\_

Protection:

Protection from Contamination by Fines? (Y/N) \_\_\_\_\_

**Figure 6-16. Checklist of critical variables for CQA of drainage materials used in a cover system.**

---

## **CHAPTER 7**

### **CONSTRUCTION QUALITY CONTROL FOR GEOMEMBRANES**

#### **PRELIMINARY DETAILS**

A number of preliminary steps must be taken to ensure that optimal construction quality control (CQC) and construction quality assurance (CQA) can be achieved at the landfill site. These steps involve manufacture, fabrication, storage at the factory, shipment, and storage at the site of the geomembrane. This chapter will focus on CQC/CQA of geomembranes, but all geosynthetics can be viewed in a similar manner.

#### ***Manufacture***

The first consideration in quality control is that the geomembrane resin, and its entire formulation, must be appropriate to the site where it will be installed. Appropriateness can be evaluated using EPA 9090 chemical compatibility testing, or by direct comparison to a local, state, or federal specification, or to a standardization group. The material may have to be chemically "fingerprinted" in some situations to assure that the delivered geomembrane has identical characteristics to the approved test samples.

The thickness, width, and length of the geomembrane also must be verified. This is best done at the manufacturer's plant, since shipment costs are high and receiving the wrong geomembrane at the job site can result in uncomfortable arguments and inconvenient delays.

Other details such as the diameter and strength of the windup core, protective covering (if appropriate), and proper marking and identification need to be assured.

#### ***Fabrication of Panels***

For certain types of geomembranes, such as polyvinyl chloride (PVC), chlorylsulfonated polyethylene-reinforced (CSPE-R), and ethylene interpolymers alloy-reinforced (EIA-R), the relatively narrow rolls (about 1.8-m [6-ft] wide) are fabricated into wider panels of about four to six roll widths. Panel fabrication requires factory seaming, usually either dielectric or bodied solvent. There should be a thin sheet of plastic over the seams to prevent one layer from sticking to the next.

The completed panels are accordion folded in two directions, wrapped in a heavy cardboard box, and placed on wooden pallets for shipment. Proper marking and iden-

tification at this stage is necessary to ensure proper delivery.

#### ***Storage at Factory***

Geomembranes stored at the manufacturer's or fabricator's facility should be elevated off the ground. They also should not be stacked so high as to deform the lower rolls or layers; warm climates are particularly troublesome in this regard. An enclosed storage space is recommended.

#### ***Shipment***

Rolls or pallets of geomembranes are usually shipped by truck to sites in the contiguous 48 states. When shipped in closed trailers, the geomembranes should be loaded and unloaded by lifting rather than by pushing and pulling. Front-end loaders equipped with long rods (called "stingers") are used for rolled geomembranes and forklift loaders are used for palletized geomembranes.

In cases where stacking of the geomembranes might be of concern, the delivery trailer should be inspected at the job site for squashed rolls or crushed boxes.

#### ***Storage at Site***

Unless the geomembrane is used directly as it comes off the shipping trailer, a safe storage area should be provided. The rolls of geomembrane should be elevated off the ground or at least placed on a dry soil area that does not contain vegetation, stumps, or other sharp objects. Covering is usually not necessary providing the geomembranes are installed within a short period of time. Palletized geomembranes should also be stored on site on dry, level ground with similar considerations.

When the geomembranes are to be stored on the site for months or longer, they should be covered and/or have an enclosure around them for protection.

#### **SUBGRADE PREPARATION**

The subgrade must be prepared according to the site-specific plans and specifications. Thus, line and grade must have been established and verified before any geomembrane is brought into the facility and positioned. There can be no sharp objects of any kind such as grade stakes, tools, stones, or equipment beneath the geomembrane.

Ruts caused by the compaction equipment or by the geomembrane placement equipment must be leveled by hand. Ruts are particularly troublesome if they freeze in their uneven profile. They must be leveled before the geomembrane is placed by waiting until the ground thaws or by breaking the uneven surfaces using pneumatic clay spades and pavement breakers.

Geomembranes should never be placed in ponded water. Such a procedure is indicative of a poor sequence of construction operations. Seaming can never be accomplished under such conditions.

## DEPLOYMENT OF THE GEOMEMBRANE

The geomembrane should be placed on the entire facility in accordance with a predetermined roll or panel layout. Layout is a site-specific consideration, but plans are generally supplied by the geomembrane manufacturer, fabricator, or installation firm. Usually the rolls or panels are ordered in a particular direction.

The construction deployment equipment should be low ground pressure units in comparison to the subgrade stability. For landfill covers, this is sometimes difficult to achieve because the waste beneath the construction operations can be actively subsiding.

After a roll, or panel, is initially positioned or "spotted," it usually must be shifted slightly for exact positioning. By lifting the liner up and allowing air to get beneath some of it, the liner can sometimes be "floated" into position. If this is not possible (e.g., with thick geomembrane sheets), the liner has to be shifted by dragging it along the subgrade (or on the geosynthetic material beneath it). The entire roll or panel must then be inspected for blemishes, scratches, and imperfections. Finally, the roll or panel is weighted down with sandbags to prevent movement by wind or any other disturbance.

Complete rolls and panels have been captured by gusts of wind and unceremoniously dumped in a corner of the facility. The owner/operator should decide beforehand, i.e., during preconstruction meetings, whether a liner in this situation can be used again or not. A number of damage scenarios should be described to anticipate such problems, since they are not that uncommon.

## GEOMEMBRANE FIELD SEAMS

There are many types of geomembrane seams, most of which were developed for a particular type of geomembrane. Table 7-1 shows methods of field seaming currently in use.

### **Solvent Seams**

*Solvent seams* use a liquid solvent placed by a squeeze bottle between the two geomembrane sheets to be joined, followed by pressure to make complete contact. As with any of the solvent-seaming processes described in this section, a portion of the two adjacent

geomembranes is actually dissolved, resulting in both liquid and gaseous phases. Too much solvent will weaken the adjoining geomembrane, and too little solvent will result in a weak seam. Therefore, great care is required in providing the proper amount of solvent for the particular type and thickness of geomembrane. Care must also be exercised in allowing the proper amount of time to elapse before contacting the two surfaces, and in applying the proper pressure and duration of rolling. These seams are used primarily on flexible thermoplastic materials.

*Bodied solvent seams* are similar except that 8 to 12 percent of the parent lining material is dissolved in the solvent before the seam is made. The purpose being to compensate for the lost material while the seam is in a liquid state and to create a viscous liquid that can be brushed on the area to be bonded. Pressure is applied, and heat guns or radiant heaters are used to aid the process.

A *solvent adhesive* uses an adherent left after the solvent dissipates. The adhesive thus becomes an additional element in the system. Sufficient pressure must be used to affect an adequate seam. Most thermoplastic materials can be seamed in this manner.

*Contact adhesives* have a wide applicability to most geomembrane types. The solution is applied to both mating surfaces by brush or roller. After reaching the proper degree of tackiness, the two sheets are placed on top of one another, and pressure is applied by a roller. The adhesive forms the bond and is an additional element in the system.









*Vulcanizing tapes and adhesives* are used on very dense thermoset materials such as butyl and EPDM. In this process, an uncured tape or adhesive containing the polymer base of the geomembrane and crosslinking agents are placed between the two sheets. Upon application of heat and pressure, crosslinking occurs, which gives the necessary bond. Factory seams are made in large vulcanizing presses or autoclaves, while field seams require a portable machine to provide the necessary heat and pressure. Since thermoset geomembranes are rarely used in landfill covers, the technique is not particularly important for our purposes.

### **Thermal Seams**

There are a number of thermal methods that can be used on thermoplastic geomembrane materials. In all of them, the opposing geomembrane surfaces are truly melted into a liquid state. Temperature, time, and pressure all play important roles: too much melting weakens the geomembrane and too little melting results in a weak seam. The same care as is necessary for solvent seams must be taken with thermal seams.

*Hot air seaming* uses a machine consisting of a resistance heater, a blower, and temperature controls to blow

**Table 7-1. Overview of Geomembrane Field Seams.**

Method	Seam Configuration	Typical Rate*	Comments
Solvent		200 ft./hr.	Requires tack time Requires hand rolling Requires cure time
Bodied Solvent		150 ft./hr.	Requires tack time Requires hand rolling Requires cure time
Solvent Adhesive		150 ft./hr.	Requires tack time Requires hand rolling Requires cure time
Hot Air		50 ft./hr.	Good to tack sheets together Hand held and automated devices Air temperature fluctuates greatly No grinding necessary
Hot Wedge		300 ft./hr.	Single and double tracks available Built in nondestructive test Cannot be used for close details Highly automated machine No grinding necessary Controlled pressure for squeeze-out
Ultrasonic		300 ft./hr.	New technique for geomembranes Sparse experience in the field Capable of full automation No grinding necessary
Fillet Extrusion		100 ft./hr.	Upper and lower sheets must be ground Upper sheet must be beveled Height and location are hand-controlled Can be rod or pellet fed Extrudate must use same polymer compound Air heater can preheat sheet Routinely used for difficult details
Flat Extrusion		50 ft./hr.	Highly automated machine Difficult for side slopes Cannot be used for close details Extrudate must use same polymer compound Air heater or hot wedge can preheat sheet

\*m = ft x .3048

air between two sheets to actually melt the opposing surfaces. Usually, temperatures greater than 260°C (500°F) are required. Immediately following the melting of the surfaces, pressure is applied by rollers. For some devices, pressure application is automated by counter-rotating knurled rollers.

In the *hot wedge* or *hot knife* method, an electrically heated resistance element in the shape of a wedge is passed between the two sheets to be sealed. As it melts the opposing surfaces, roller pressure is applied. Most of these seaming units are automated in terms of temperature, speed of travel, and amount of pressure applied. An interesting variation of the technique is the dual-hot-wedge method, which forms two parallel seams with an unbonded space between them. This space is subsequently pressurized with air and any lowering of pressure signifies a leak in the seam. Lengths of hundreds of feet can be field tested in this one step. The hot wedge or hot knife method will be more fully described in the section on nondestructive seam testing.

*Dielectric bonding* is used only for factory seams of flexible thermoplastic geomembranes. In this method, an alternating current, at a frequency of approximately 27 MHz, excites the polymer molecules, creating friction and thereby generating heat. This heat melts the polymer, and when followed by pressure, results in a seam. A variation of this method, called ultrasonic seaming, has recently been introduced for the manufacture of field seams on polyethylene liners.

*Ultrasonic bonding* utilizes a generated wave form of 40 kHz, which produces a mechanical agitation of the opposing geomembrane surfaces. Following the melting process, a set of knurled wheels is used to mix and apply pressure to the material.

*Electric welding* is yet another new technique for polyethylene seaming. In this technique, a stainless steel wire is placed between overlapping geomembranes and is energized with approximately 36 volts and 10 to 25 amps current. The hot wire radially melts the entire region within about 60 seconds, thereby creating a bond. It is later used as a nondestructive testing method with a low current and a questioning wire outside of the seamed region.

### **Extrusion Seams**

*Extrusion (or fusion) welding* is used exclusively on polyethylene geomembranes. It is directly parallel to metallurgical welding in that a ribbon of molten polymer is extruded between or against the two slightly buffed surfaces to be joined. The extrudate ribbon causes some of the sheet material to be liquefied and the entire mass then fuses together. One patented system has a mixer in the molten zone that aids in homogenizing the extrudate and the molten surfaces. The technique is called *flat welding* when the extrudate is placed between the two sheets to be joined and *fillet welding* when the extrudate

is placed over the leading edge of the seam to be bonded.

### **DESTRUCTIVE SEAM TESTS**

After a field-seaming crew has seamed a given amount of material, it is important to evaluate their performance. One procedure is to cut out a sample, send it to a laboratory, and test it until failure in either shear or peel modes (see Figure 7-1). Another option would be to test it directly at the field site. But considering a geomembrane sheet layout, where should the seam be tested and in how many places? Because each seam sample becomes a hole that must be appropriately patched and then retested, the number of field-seam samples is commonly reduced to a bare minimum. Then only the method of seaming is assessed, not its continuity. The method includes installation type, temperature, dwell time (time during which seam is under pressure), pressure, and other operational details affecting seam quality. Samples will ordinarily be taken at the start of the seaming operations in the morning and at the midday break. Thereafter, sampling can be done on a random or a periodic basis. Haxo (1) recommends a frequency of six samples per km (6/3,300 ft) of seam on a random basis, or one sample per 150 m (1/500 ft) of seam on a uniform basis.

There is much current discussion on what constitutes an acceptable seam. Nearly everyone agrees that the seam test specimen must not fail within the seamed region itself; that is, a failure must be a sheet failure on either side of the seamed region. This is called a "film-tear bond" failure. Engineers are not in agreement, however, as to the magnitude of the force required for failure. For

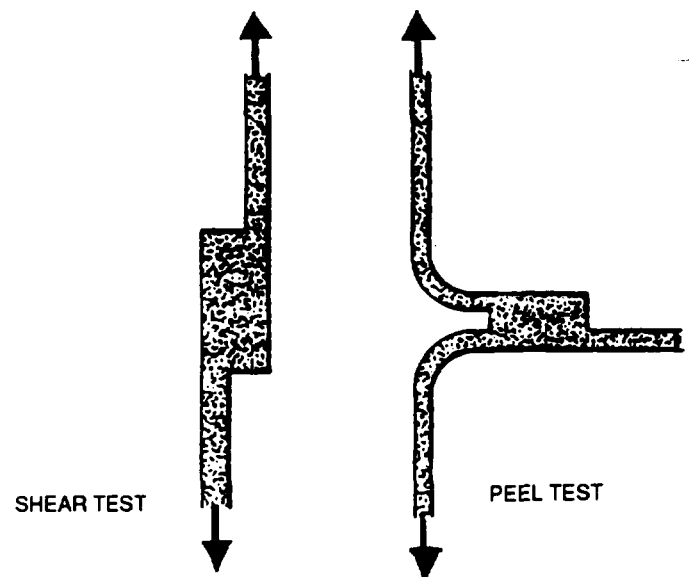

Figure 7-1. Shear and peel test for geomembrane seams.

seams tested in a shear mode, failure forces of 80 to 100 percent of the unseamed sheet strength are usually specified. For seams tested in a peel mode, failure forces of 50 to 80 percent of the unseamed sheet strength are often specified. These percentages underscore the severity of peel tests as compared to shear tests. For assessing seam quality, the peel test is preferable.

### NONDESTRUCTIVE SEAM TESTS

Although the method of seaming must be properly assessed, the test tells nothing of the continuity and completeness of the entire seam. It does little good if one section of a seam has 100 percent of the strength of the parent material, if the section next to it is missed completely by the field-seaming crew. Thus, this section discusses only continuous methods of nondestructive testing (NDT). In each of these methods, the goal is to check 100 percent of all seams (see Table 7-2).

The *air lance* method projects a jet of air at approximately 350 kPa (50 lb/in.<sup>2</sup>) pressure through an orifice of 5-mm (3/16-in.) diameter. The jet is directed beneath the upper edge of the overlapped seam to detect unbonded areas. When such an area is located, the air passes through, causing an inflation and fluttering in the localized area. This method only works on relatively thin (less than 45 mils [1.1 mm]), flexible geomembranes, and only if the defect is open at the front edge of the seam, where the air jet is directed. It is strictly a contractor/installer's tool to be used in a CQC manner.

In the *mechanical point stress* or "*pick*" test, the tester places a dull tool (such as a blunt screwdriver) under the top edge of a seam. With care, an individual can detect an unbonded area, because it is easier to lift than a properly bonded area. This rapid test depends completely on the care and sensitivity of the person performing it. Only relatively thick, stiff, geomembranes are checked by this method. Detectability is similar to that using the air lance, but both methods are very operator dependent. This test also is to be performed only by the installation contractor and/or geomembrane manufacturer. Design or inspection engineers should use one or more of the techniques discussed below.

*Electric sparking* is an old technique used to detect pinholes in thermoplastic liners. In this method, a high-voltage (15 to 30 kV) current detects any leakage to ground (through an unbonded area) by producing sparking. The method is not very sensitive to overlapped seams of the type generally used in geomembranes and is used only rarely for this purpose. Today, the technique has been revived in a somewhat varied form. In the *electric wire* method, a copper or stainless steel wire is placed between the overlapped geomembrane region and is actually embedded into the completed seam. After seaming, a charged probe of about 20,000 volts is connected to one end of the wire and slowly moved over the length of the seam. A seam defect between the probe and the embedded wire produces an audible alarm from the unit. The method is strongly advocated by some installation

**Table 7-2. Overview of Nondestructive Seam Tests.**

Nondestructive Test Method	Primary User			General Comments					
	Contractor	Design Engineer Inspector	Third-Party Inspector	Cost of equipment	Speed of tests	Cost of tests	Type of Result	Recording Method	Operator Dependency
air lance	yes	-	-	\$200	fast	nil	yes-no	manual	very high
pick test	yes	-	-	nil	fast	nil	yes-no	manual	very high
electric wire	yes	yes	-	\$500	fast	nil	yes-no	manual	high
dual seam (positive pressure)	yes	yes	-	\$200	fast	mod.	yes-no	manual	low
vacuum chamber (negative pressure)	yes	yes	-	\$1000	slow	very high	yes-no	manual	high
ultrasonic pulse echo	-	yes	yes	\$5000	moderate	high	yes-no	automatic	moderate
ultrasonic impedance	-	yes	yes	\$7000	moderate	high	qualitative	automatic	unknown
ultrasonic shadow	-	yes	yes	\$5000	moderate	high	qualitative	automatic	moderate
electric field	yes	yes	yes	\$20,000	slow	high	yes-no automatic	manual and	low
acoustic sensing	yes	yes	yes	\$1000	fast	nil	yes-no	manual	moderate

firms, but the literature gives conflicting opinions when comparing this method to vacuum box testing (discussed below).

The *pressurized dual seam* method was mentioned earlier in connection with the double-wedge thermal seaming method. The air channel that results between the double seam is inflated using a hypodermic needle and pressurized to approximately 200 kPa (30 lb/in.<sup>2</sup>) for a length of 30 to 300 m (100 to 1,000 ft). If no drop on a pressure gauge occurs, the seam is acceptable; if a drop occurs, a number of actions can be taken:

- The distance can be systematically halved until the leak is located.
- The section can be tested by some other leak detection method.
- A cap strip can be seamed over the entire edge.

The test is an excellent one for long, straight-seam runs. It is generally performed by the installation contractor, but often with the designer or inspector observing the procedure and assessing the results.

*Vacuum chambers (boxes)* are the most common form of nondestructive test currently used by design engineers and CQA inspectors. In the vacuum chambers method, a 1-m (3-ft) long box with a transparent top is placed over the seam and a vacuum of approximately 17 kPa (2.5 lb/in.<sup>2</sup>) is applied. When a leak is detected, the soapy solution originally placed over the seam bubbles, thereby reducing the vacuum. The vacuum is reduced due to air entering from beneath the liner and passing through the unbonded zone. The test is slow to perform and it is often difficult to make a vacuum-tight joint at the bottom of the box where the box passes over the seam edges. Due to upward deformations of the liner into the vacuum box, only geomembrane thicknesses greater than 30 mils (0.75 mm) should be tested in this manner. It would be difficult to test 100 percent of the field seams by this method, however, because of the large number of field seams and the amount of time required. The test could also not inspect around sumps, anchor trenches, and patches with any degree of assurance. The method is also essentially impossible to use on side slopes, since the downward pressure required to make a good seal cannot be obtained (it is usually done by standing on top of the box).

A number of ultrasonic methods are available for seam testing and evaluation. The *ultrasonic pulse echo* method is basically a thickness measurement technique and is only used with semicrystalline geomembranes. In this method, a high-frequency pulse is sent into the upper geomembrane and (in the case of a good seam) reflects off of the bottom of the lower one. If, however, an unbonded area is present, the reflection will occur at the unbonded interface. The use of two transducers, a pulse generator, and a CRT monitor are required. The

ultrasonic pulse echo test cannot be used for extrusion fillet seams, because of their nonuniform thickness.

The *ultrasonic impedance plane* method works on the principle of acoustic impedance. A continuous wave of 160 to 185 kHz is sent through the seamed liner, and a characteristic dot pattern is displayed on a CRT screen. The dot pattern is calibrated to signify a good seam. The method has potential for all types of geomembranes but still needs additional development work.

The *ultrasonic shadow* method uses two roller transducers: one sends a signal into the upper geomembrane and the other receives the signal from the lower geomembrane on the other side of the seam. The technique shows an energy transmitted on the display monitor. HDPE seams with received signals greater than 50 percent full-scale height were all found to be acceptable by subsequent testing with destructive methods. Received signals less than 20 percent full-scale height indicated that the seams were not acceptable. The 50 to 20 percent range had mixed results. This technique can be used for all types of seams, even those in difficult locations, such as around manholes, sumps, and appurtenances. It is best suited to semicrystalline geomembranes, such as HDPE, and will not work for scrim-reinforced liners.

The *electric field* test utilizes a liquid-covered geomembrane to contain an electric field. For this method to work, the entire bottom of the lined facility must be covered with liquid, usually water. The depth can be nominal, approximately 15 cm (6 in.). Electric field testing cannot be used where water does not cover the geomembrane, as on side slopes. This method uses a current source to inject current across the boundary of the liner. When a current is applied between the source and remote current return electrodes, current flows either around the entire site (if no leak is present) or bypasses the longer travel path through the leak itself (when one is present). Potentials measured on the surface are affected by the distributions and can be used to locate the source of the leak. These potentials are measured by "walking" a probe in the water. The operator walks on a predetermined grid layout and marks where anomalies exist. After the survey is completed, these anomalies can be rechecked by other methods, such as the vacuum box. Electric field testing is currently commercially available.

*Acoustic sensing* is used in conjunction with the dual seam air pressure test. It is an effective method to locate a leak if air pressure is not maintained.

## **PENETRATIONS, APPURTENANCES, AND MISCELLANEOUS DETAILS**

The various details of a geomembrane landfill closure are very important in making the entire "system" function as intended. Clearly, gas venting must be addressed in any

---

closure over biodegrading solid waste landfills. Gas venting pipes are usually constructed with prefabricated "boots" around PVC or HDPE pipes. The geomembrane is then seamed to the pipe according to the proper technique. If metal pipes are used, a stainless steel clamp usually makes the connection.

Other appurtenances and details might need to be considered and details in the open literature should be evaluated accordingly. The landfill owner/operator must

always keep in mind that the waste will subside over time and typically in a very nonuniform and random manner.

#### REFERENCE

1. Haxo, H.E.J. 1986. Quality assurance of geomembranes used as liners for hazardous waste containment. *Journal of Geotextiles and Geomembranes*. Vol. 3, No. 4, pp. 225-248.

## CHAPTER 8

# HYDROLOGIC EVALUATION OF LANDFILL PERFORMANCE (HELP) MODEL FOR DESIGN AND EVALUATION OF LIQUIDS MANAGEMENT SYSTEMS

### INTRODUCTION

Liquids management systems are critically important for limiting leachate generation and migration. Cover systems control leachate generation by restricting infiltration of precipitation into the waste layer. Leachate collection and liner systems restrict migration of leachate from the waste containment site by limiting leakage through liners and promoting leachate collection. This chapter looks at using the Hydrologic Evaluation of Landfill Performance (HELP) model in the design and evaluation of these systems.

This chapter presents a brief overview of typical liquids management systems, a detailed description of the HELP model, and an example application of the HELP model simulating a complete landfill system.

### OVERVIEW

Landfills typically contain two liquids management systems. The cover is the principal liquids management system for controlling leachate generation. Leachate, as evaluated by the HELP model, is any rainfall or snowmelt that combines with liquids in the waste and moves by gravity forces to the bottom of a landfill. During its migration through the waste, the liquid takes on pollutants that

are characteristic of the waste. As such, the leachate quantity and quality is site specific and waste specific.

The HELP model generates estimates of leachate quantity given site-specific descriptions of climate, cover design, and initial moisture content of the waste and soil layers. The model does not predict leachate quality or any contribution to the leachate quantity by subsurface inflow of ground water. Good landfill design and site selection would minimize any contribution from ground water.

### Covers

Figures 1-1 and 1-2 (see Chapter 1, pp. 1-3 and 1-7) show typical cover designs recommended in the U.S. EPA technical guidance document *Final Covers on Hazardous Waste Landfills and Surface Impoundments* (1). The designs are composed of three layers for liquids management—vegetation/soil or cobbles/soil top layer, drainage layer, and geomembrane liner/low hydraulic conductivity soil layer (hydraulic barrier layer). The other components in the design serve to support or maintain the functions of these three layers.

The topsoil layer should be designed to promote runoff from major storms, provide storage for evapotranspiration, and protect the hydraulic barrier layer from frost

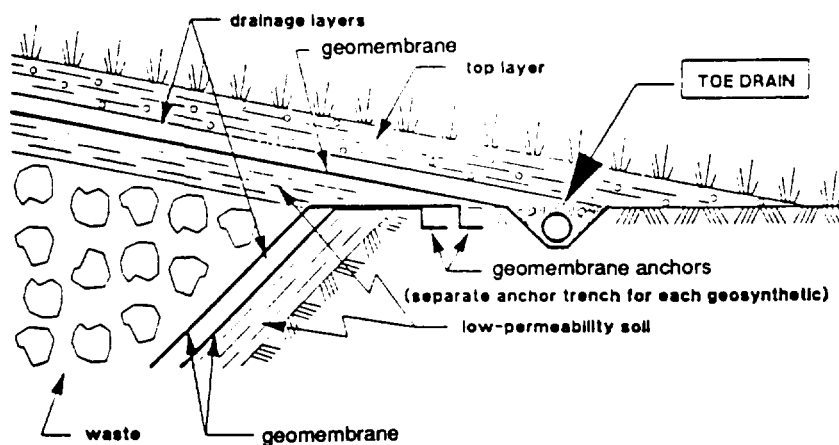

Figure 8-1. Cover and liner edge configuration with example toe drain.

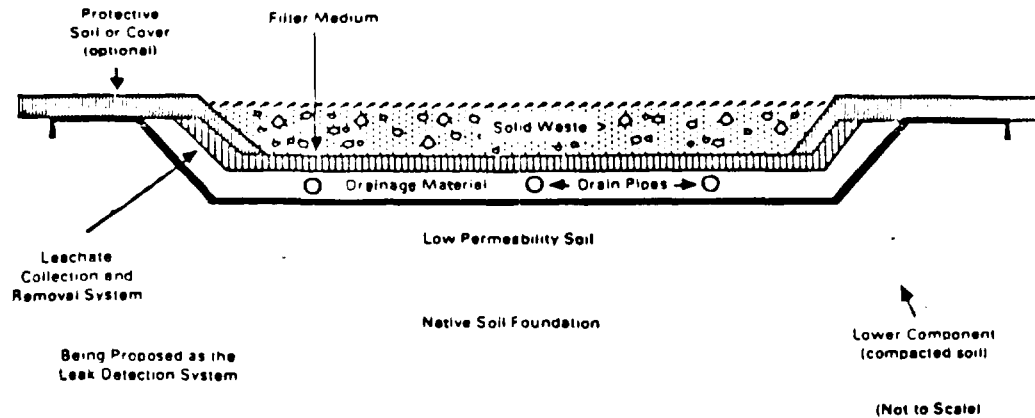

Figure 8-2. Schematic of a single clay liner system for a landfill.

penetration and desiccation. Above all other considerations, the topsoil, if vegetated, should have good moisture retention properties. A clayey soil promotes runoff, slows drainage, and provides storage for evapotranspiration; however, it also can promote desiccation to greater depths and retard vegetative growth.

Runoff promotes erosion and degradation of the cover system. Vegetation or cobbles impede erosion and support the long-term integrity of the cover. The thickness of the topsoil layer must be sufficient to retain adequate moisture for maintaining vegetation and to ensure that frost and desiccation will not penetrate to the hydraulic barrier layer. Typically, a thickness of 60 to 90 cm (2 to 3 ft) is sufficient, but the actual requirement is site and design specific.

The drainage layer should be designed to reduce leakage through the hydraulic barrier layer. This is accomplished by draining the zone of saturation above the barrier to a collection pipe or toe drain, as shown in Figure 8-1 (2). This design lowers the hydraulic head driving the leakage and decreases the quantity of water available to leak through the barrier. All drainage layers should be designed to have free drainage to a collection system to maximize the drainage for a given system. Absence of a toe drain at the base of the side slope of the cover system also can contribute to slope failures.

The drainage layer also reduces root and animal penetration of the hydraulic barrier layer and provides additional depth and a capillary break to lessen desiccation and frost penetration of the barrier. As shown in Figures 1-1 and 1-2, a filter, either soil or geotextile, must be placed above the drainage layer to decrease migration of fines and prevent the fines from clogging the drain. Drainage layers are not necessary at all sites since some sites may not have sufficient rainfall and infiltration to produce standing head on the hydraulic barrier for long durations.

The hydraulic barrier layer or liner should be designed to minimize the infiltration of water into the waste layer over the long term. The liner systems shown in Figures 1-1 and 1-2 are both composite systems, but municipal waste landfills have commonly used only a low hydraulic conductivity soil liner. Use of a geomembrane in conjunction with low hydraulic conductivity soil greatly improves the effectiveness of the barrier. In conventional cover designs, the barrier layer is the most important layer in controlling leakage through the cover system. All other layers tend to serve mainly as layers that support and maintain the barrier. Generally, except in arid or semiarid areas, the topsoil layer cannot promote sufficient runoff and evapotranspiration to prevent leakage. Drainage layers typically cannot drain all of the water passing through the topsoil layer before it reaches the barrier. Once water stands on the barrier, leakage occurs at a rate controlled by the barrier.

#### Leachate Collection/Liner Systems

The second liquids management system used in a landfill is the leachate collection/liner system. A typical single liner system used for leachate collection is shown in Figure 8-2 (2). It consists of a drainage layer overlain by a filter, either soil or geosynthetic, and a hydraulic barrier layer composed of hydraulic conductivity soil. The soil liner is frequently overlain by a geosynthetic geomembrane to greatly improve its performance. The performance of these layers for liquids management is the same as described above for cover systems except that the layers are controlling leakage from the landfill instead of infiltration into the waste layer and leachate generation.

Figure 8-3 is a schematic of a typical double liner system used both for leachate collection and leakage detection (2). The top drainage layer and geomembrane is the primary leachate collection system. The bottom drainage

layer and composite liner (low hydraulic conductivity soil overlain by a geomembrane) is the secondary leachate collection system and leakage detection system.

## HELP MODEL

### Background

The HELP model was developed by the U.S. Army Engineer Waterways Experiment Station for the U.S. EPA Office of Solid Waste (OSW) to provide technical support for the Resource Conservation and Recovery Act (RCRA) and Comprehensive Environmental Response, Compensation, and Liability Act (CERCLA) programs. Development of the model began in 1982 and Version 1 was released for public comment in June 1984 (3,4). The program was a mainframe computer model that ran on the National Computer Center's IBM system. In 1986, the program was modified to run on IBM-compatible personal computers. Additional capabilities and refinements were included in Version 2 of the model released in 1988 (5, 6). The most current version is Version 2.05, which was released in July 1989. Version 3 of the model is currently in preparation for release in 1991.

The HELP model is a quasi-two-dimensional, gradually varying, deterministic, computer-based water budget model. It is termed quasi-two-dimensional because it contains a one-dimensional vertical drainage model and a one-dimensional lateral drainage model coupled at the base of lateral drainage layers or the top of liners. The program computes free vertical drainage down to the top of a liner, at which point the liner restricts drainage and a zone of saturation develops. The models for lateral drainage and leakage or percolation through the liner then use the height of saturated material above the liner to compute simultaneously the rates of lateral drainage to collection systems and vertical leakage through the liner, respectively. The model is termed gradually varying because the simulation progresses through time using

analyses that are assumed steady for each time period. Version 2 of the model uses a time period of 6 hours. The model is deterministic and numerical as opposed to stochastic and qualitative. Finally, the HELP model is a computer-based water budget model; that is, the model uses a computer to apportion the precipitation and initial moisture content into estimates of the following water budget components: surface runoff, evapotranspiration, changes in snow storage, changes in moisture content, lateral drainage collected in each drain system, and leakage or percolation through each liner system. Figure 8-4 shows a schematic of the processes and systems modeled by the program. Daily, monthly, annual, and long-term average water budgets can be generated.

The HELP model is a tool developed specifically to aid permit evaluators and landfill designers in the evaluation and comparison of alternative landfill designs. The model was built to evaluate whether alternative designs perform as well as the minimum technical guidance systems over a long period of time. Therefore, its primary utility is for tasks involving comparison of alternative designs and sensitivity of design parameters. A secondary goal of the model's development was the accurate prediction of water budget components. Nevertheless, additional testing, verification studies, and refinements are ongoing to improve its accuracy. In general, the accuracy and precision of the model is limited by uncertainty and variability in the properties of material existing in landfills. As such, simulation results would be expected to be best used to rate relative merits of designs rather than to accurately predict the water budget components.

The HELP model is a valuable tool for design and permit evaluation; however, it requires the user to exercise good judgment. In particular, the user must have a good understanding of landfill design, vegetative systems, and the model to obtain reliable results and correct conclusions. The user must ensure the integrity of the design and the data because the model does not evaluate the data.

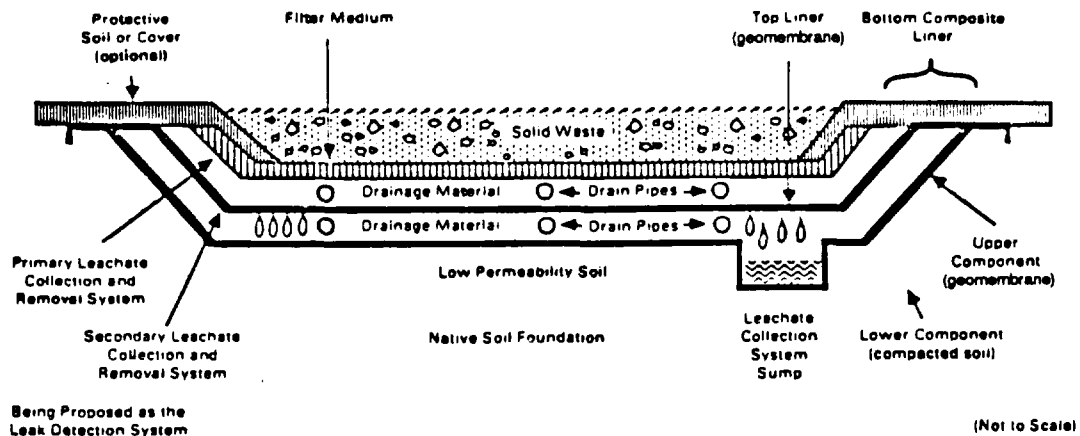

Figure 8-3. Schematic of a double liner and leak detection system for a landfill.

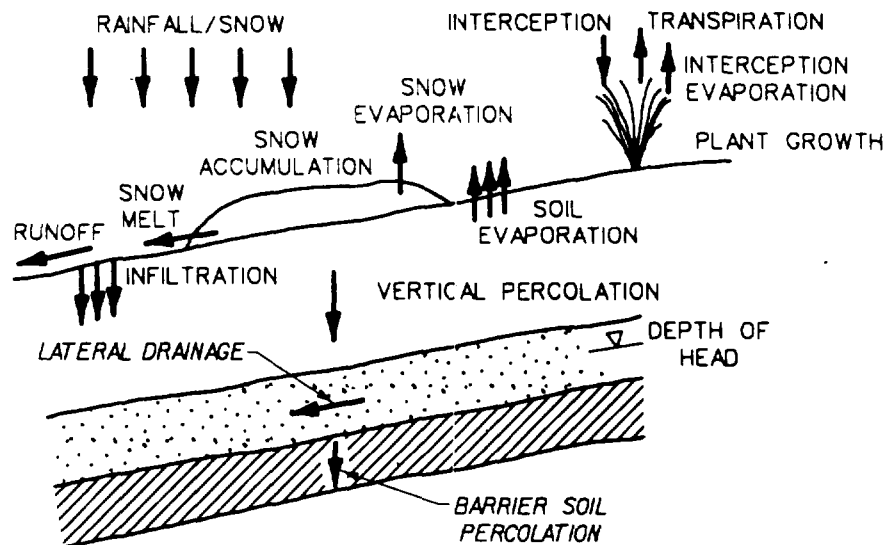

Figure 8-4. Simulation processes in the HELP model.

An example of a cover system lacking design and data integrity is a two-layer system with the following characteristics. The top layer is 5 cm (2 in.) of topsoil vegetated with a good stand of grass. The lower layer is 5 cm (2 in.) of compacted clay having a saturated hydraulic conductivity of  $10^{-8}$  cm/sec. With this description, the HELP model would predict a very large quantity of runoff and a small quantity of evapotranspiration since the topsoil layer has very little storage capacity. In addition, very little leakage through the clay liner would be predicted because the saturated hydraulic conductivity of the liner is so low. The actual results would be expected to be quite different. Construction of 5-cm (2-in.) layers is not practicable, especially, construction of a thin lift of clay compacted uniformly to achieve an effective hydraulic conductivity of  $10^{-8}$  cm/sec. Besides the difficulties in construction, the layers would lack integrity to maintain the described properties. Both layers would quickly form desiccation cracks, producing much larger hydraulic conductivities. As such, the leakage and evapotranspiration would be much greater than predicted and the runoff would be much less.

The primary anticipated use of the HELP model—to perform quick comparisons of the long-term performance of alternative designs, often with very little data—was considered throughout its development. As such, the following approach was taken to select simulation methods and data entry options. Process simulation methods had to be well-accepted techniques described in the literature that are computationally efficient, require minimum data that are readily available, and account for all major design and climate conditions. Conservative assumptions are made when necessary because of uncertainty. The term

"conservative" implies that any resulting error would tend to result in an overestimation of vertical drainage or leakage through liners. Options are provided to permit use of data from a default data base or from user entry. Guidance and recommendations are given for poorly understood parameters. In addition, the program is interactive and user friendly and runs on IBM-compatible personal computers to facilitate widespread use.

#### Process Simulation Methods

The HELP model was adapted from the Hydrologic Simulation Model for Estimating Percolation at Solid Waste Disposal Sites (HSSWDS) of the U.S. EPA (7, 8) and the Chemical Runoff and Erosion from Agricultural Management Systems (CREAMS) (9) and Simulator for Water Resources in Rural Basins (SWRRB) models of the U.S. Department of Agriculture (USDA) Agricultural Research Service (ARS) (10). The following sections of this chapter describe all of the principal hydrologic and physical processes modeled by the HELP model, including a discussion of the assumptions and limitations of the models of the principal processes. Many of the processes are shown on a schematic of a closed landfill profile in Figure 8-4. Understanding of the processes, simulation methods, and their assumptions and limitations is critical for the proper application of the HELP model.

#### Infiltration

Daily infiltration into the landfill is determined indirectly from a surface water balance. Infiltration equals the sum of rainfall and snowmelt, minus the sum of runoff and surface evaporation. Runoff and surface evaporation are in part a function of interception. Precipitation on days having a mean temperature below  $0^{\circ}\text{C}$  ( $32^{\circ}\text{F}$ ) is treated

as snowfall and is added to the surface snow storage. Decreases in snow storage occur by snowmelt and surface evaporation.

Daily precipitation is an input parameter. Precipitation data may be synthetically generated, specified by the user, or selected from the default data base of historical rainfall data. The synthetic weather generator will be described later in this chapter.

Snowmelt is computed using a slightly modified version of the simple degree-day method with 0°C (32°F) as the base temperature (11). The in./degree-day snowmelt constant was increased from 0.06 to 0.10, a value more typical of open areas. In addition, the modification permits a small quantity of snowmelt to occur at mean daily temperatures between -5° and 0°C (23° and 32°F) to account for the variation in temperature during a day and for the fact that landfills often have higher soil temperatures because of heat generated from biodegradation. Snowmelt contributes to runoff, evaporation, and infiltration.

Interception is modeled after the work of Horton (12). Interception approaches a maximum value exponentially as the rainfall increases to about 0.5 cm (0.2 in.). The maximum interception is a function of the quantity of aboveground biomass or leaf area index and is limited to a maximum of 0.13 cm (0.05 in.). The interception evaporates from the surface and decreases the evaporative demand placed on the plants and soil column.

The HELP model uses the Soil Conservation Service (SCS) curve number method for estimating surface runoff, as presented in the Hydrology Section of the National Engineering Handbook (11). The SCS curve number method is an empirical method developed for small watersheds (about 12.1 to 202.4 hectares [30 to 500 acres]) with mild slopes (about 3 to 7 percent). The method correlates daily runoff with daily rainfall for watersheds with a variety of soils, types of vegetation, land management practices, and antecedent moisture conditions (levels of prior rainfall). As applied, the technique accounts for changes in runoff as a function of soil type, soil moisture, and vegetative conditions. Version 3 of the model will include a procedure to adjust the curve number as a function of surface slope since surface slopes greater than 20 percent can produce significantly greater runoff.

Many assumptions and limitations exist in the application of this method in the HELP model, including the following:

- The SCS curve number method is applicable for landfills that are much smaller in area than watersheds. Verification studies have shown good agreement between the predicted and observed cumulative annual volume of runoff.
- Cumulative volume of runoff is independent of rainfall duration and intensity since over a long simulation

period a variety of precipitation events will occur. The predicted value represents an average of the measured runoff for the typical variety of rainfall events of a given quantity.

- No surface run-on from surrounding areas is permitted by the model.
- Estimates of runoff greater than predicted by the SCS curve number method are produced when the surface soils are saturated or limit infiltration due to very low hydraulic conductivity.

### Evapotranspiration

Evapotranspiration consists of three components: evaporation of water from the surface, from the soil, and from the plants. Each component is computed separately. Evaporation of water from the surface is limited to the smaller of the potential evapotranspiration and the sum of the snow storage and interception. The HELP model uses a modified Penman method to compute potential evapotranspiration. This method, developed by Ritchie (13), is also used in the CREAMS program (9). The potential evapotranspiration is a function of ground cover, daily temperature, and daily solar radiation. Evaporation of surface water decreases the evaporative demand placed on the plants and soil column.

The HELP model uses Ritchie's method of evaporation from soil (13) as applied in the CREAMS (9) and SWRRB (10) models. The method uses a two-stage, square root of time routine. In stage one, the soil evaporation equals the evaporative demand placed on the soil column. Demand is based on energy and is equal to the potential evapotranspiration discounted for surface evaporation and shading from ground cover. A vegetative growth model is used to compute the total quantity of vegetation, both active and dormant, which provides shading. In stage two, evaporation from the soil column is limited by low soil moisture and low rates of water vapor transport to the surface by soil suction. Stage two soil evaporation is a function of the square root of the length of time that the soil has been in this dry condition.

The HELP model estimates plant transpiration in the manner of the CREAMS and SWRRB models (9, 10) whereby the potential plant transpiration is a linear function of the potential evapotranspiration and the active leaf area index. The leaf area index of actively transpiring plants is computed using a vegetative growth model that accounts for seasonal variation in active and dormant aboveground biomass and leaf area index. This model was extracted from the SWRRB model developed by the USDA ARS (10). See "Vegetative Growth" later in this chapter for a complete description of this model.

Many assumptions and limitations exist in the application of this three-component evapotranspiration method in the HELP model, including the following:

- The potential evapotranspiration is a function solely of the energy available at the surface and, therefore, is not a function of energy produced in the landfill, soil temperature, wind, and humidity. As such, the program uses a vapor pressure gradient that is a function solely of mean daily ambient air temperature.
- A constant value is used for the albedo (fraction of incident solar radiation that is reflected). The value is typical for brown soils and grasses and is modified only when the surface is covered with snow.
- The program uses a constant evaporative zone depth. This depth is the maximum depth to which soil suction can draw water to the surface. The depth is a function of soil properties, design, vegetation, and climatic conditions.
- Ritchie's two-stage soil evaporation method is applicable for all materials, not just soils.
- Synthetically generated daily temperature and solar radiation values are sufficient for estimating potential evapotranspiration.
- The vegetative growth model produces representative leaf area indices and biomass estimates that are sufficient to estimate interception, surface shading, and plant transpiration.

### Subsurface Water Routing

Subsurface water routing processes modeled by the HELP model include vertical unsaturated drainage, percolation through saturated soil liners, leakage through geomembranes, and lateral saturated drainage. In modeling these processes, the soil moisture of each layer of the landfill profile being modeled is computed by sequential analysis proceeding forward through time. The soil moisture controls the rate of subsurface water movement by each of the subsurface processes, but the rates of water movement by these subsurface processes yield the resulting soil moisture. Consequently, the soil moisture and rates of subsurface water routing are computed simultaneously in the HELP model by an iterative process after accounting for extractions by soil evaporation and plant transpiration.

The HELP model simulates unsaturated vertical drainage using a unit hydraulic pressure gradient approach (saturated Darcy's law) where drainage occurs at a rate equal to the unsaturated hydraulic conductivity. Under this approach, vertical water routing is only downward except in the evaporative zone where water is removed upward by evapotranspiration. The unsaturated hydraulic conductivity is computed by the Campbell equation using Brooks-Corey soil parameters to define the shape of this power function (14, 15). This approach incorporates the moisture retention properties (capillarity) of the soil in the determination. The model considers limited interactions between layers of materials. As such, the model does not allow drainage from one layer at a rate greater than the

maximum infiltration rate of the layer below it, allowing placement of a lower hydraulic conductivity nonlinear layer below a layer of higher hydraulic conductivity.

Future versions may consider soil matrix interactions in the recommendation of values for the evaporative zone depth and in the selection of the moisture content where the drainage from one layer into another will cease. These additions will better model the physical situations where fine-grained materials overlie coarse-grained materials. In these situations, the coarse-grained material may restrict the depth of evapotranspiration and the fine-grained material may retain a higher water content before draining into the coarse-grained material despite very low water content in the coarse-grained material. Conversely, coarse-grained material overlying fine-grained material will restrict the transport of water vapor up from below for evaporation but will freely drain to very low moisture contents. These phenomena occur because the soil suction of fine-grained material is much greater than that of coarse-grained material.

Vertical drainage through saturated soil liners is termed percolation in the HELP model. The barrier soil liners are assumed to remain permanently saturated, but percolation occurs only when there is a zone of saturation directly above the liner. Percolation is computed by Darcy's law using the saturated hydraulic conductivity of the liner material. The head loss gradient is equal to the average head above the base of the liner divided by the thickness of the liner.

Leakage through geomembranes is modeled as a reduction of the cross-sectional area of flow through the subsoil below the geomembrane. The rate of flow through the leaking subsoil is computed as the percolation rate through a saturated barrier soil liner. This method provides good results for composite liners but is not very good for just a geomembrane. Therefore, Version 3.0 include an improved leakage model for geomembranes based on the work of Brown (16) and Giroud et al. (17, 18, 19).

The HELP model simulates lateral drainage using a steady-state analytical approximation of the numerical solution of the Boussinesq equation (Darcy's law for saturated lateral flow through unconfined porous media coupled with the continuity equation). The analytical approximation was developed by converting the Boussinesq equation into a nondimensional form and solving it for two analytical solutions at the extremes in nondimensional average saturated depth. These two solutions were then fitted with the same value and slope in an approximation that covers the rest of the range of nondimensional depths. The approximation matched the numerical steady-state solution of the Boussinesq equation within 1 percent of the predicted drainage rate. The solution is not linear; therefore, the HELP model uses a Newton-Raphson method to converge onto the solution

of the nonlinear approximation. The model uses the average depth of saturation in the approximation since the HELP model is quasi-two-dimensional and, therefore, cannot determine the saturated depth profile. The lateral drainage, percolation, and leakage through the geomembrane are solved simultaneously with the average depth of saturation using an implicit solution technique.

Many assumptions and limitations exist in the application of the subsurface water routing methods, including the following:

- All flow is considered to follow Darcy's law. As such, the only driving force for water routing is gravity, and all movement has a downward component.
- All layers of materials are spatially homogeneous and uniform. All properties of the layers and materials not related to soil moisture are assumed to remain constant throughout the simulation.
- No subsurface inflow occurs. The layers being modeled are above the surrounding water table or cut off from it.
- Brooks-Corey relationships and the Campbell equation are applicable for estimating the unsaturated hydraulic conductivity of all types of materials.
- Percolation and leakage through liner systems occur only when a zone of saturation (head) lies on the top surface of the liner. The zone covers the entire area of the liner and, therefore, percolation and leakage are spatially uniform.
- The liner and drainage layers cover the entire area of the landfill since the water routing in the vertical and lateral directions is performed separately by one-dimensional models.
- The liner system is permanently saturated and the pressure head at the base of the liner is zero (liner is above the water table).
- Synthetic liners (geomembranes) are impermeable except through specific failure points (holes, punctures, cracks, faulty seams, etc.) and function by reducing the area of flow through the subsoil beneath the liners.
- The rate of leakage through geomembranes is mainly a function of the number of holes, depth of saturation above the liner, and the saturated hydraulic conductivity of the subsoil.
- The saturated depth profile (water table) in the lateral drainage layer is typical of steady-state drainage and gradually varies between different steady-state profiles characteristic for different depths of saturation as the simulation progresses.
- The lateral drainage rate can be reliably estimated from the average depth of saturation throughout the

drain layer which is estimated from the average soil moisture content of the drain layer.

- The depth of saturation at the edge of the drain layer or at the collector is zero. Therefore, lateral drainage is not retarded by standing water in the drain trench.

### **Vegetative Growth**

The HELP model accounts for seasonal variation in active and dormant aboveground biomass and leaf area index through a general vegetative growth model. This model was extracted from the SWRRB model developed by the USDA ARS (10). The vegetative growth model computes daily values of biomass and leaf area index based on a maximum allowable value from input, daily temperature and solar radiation data, and the beginning and ending dates of the growing season. The maximum value of leaf area index depends on type of vegetation, soil fertility, climate, and management factors. The program supplies typical values for selected covers; these range from 0 for bare ground to 5.0 for an excellent stand of grass. The HELP model maintains a data file containing mean monthly temperatures and beginning and ending dates of the growing season for 183 locations in the United States. Vegetative growth is a linear function of the available solar radiation during the first 75 percent of the growing season. Growth can be limited by temperatures below 10°C (50°F) and low soil moisture. Vegetative decay is modeled as exponential decay and is also a function of temperature and soil moisture. The decay process is modeled continuously, during both the active growing and dormant seasons.

### **Accuracy**

As stated previously, the primary purpose of the model is to simulate alternatives for comparison, showing relative value of alternatives and sensitivity of design parameters. The secondary purpose is to quantify the water budget components accurately. Generation of accurate predictions requires good understanding of the model, hydrologic processes, and landfill design and construction. In addition, accurate data describing the properties and variability of all materials and the climate are essential.

Even with the best of data and knowledge of the model and landfill, significant errors should be expected in the estimates of the water budget components due to minimum data requirements and limitations in the modeling techniques. The following error bounds are believed to be generally achievable when extensive and accurate data are available to a knowledgeable user (ideal circumstances). The cumulative annual total for a water budget component can typically be estimated within the larger of the following error bounds: 25 percent of the total or 2 percent of the precipitation for the surface runoff component, 10 percent of the total or 7 percent of the precipitation for the evapotranspiration component, and

10 percent of the total or 0.1 percent of the precipitation for the percolation or leakage through liners component. The error bound for cumulative annual lateral drainage to collection systems is about 7 percent of the precipitation and is equal to the sum of the other errors. Its error is dependent on all other errors because those processes occur first and any excess or shortfall in the extraction by those processes controls the quantity of water available for lateral drainage. These error bounds would be several times larger when simulations are run with poor data and a poor understanding of the model and landfill design.

### **Input Requirements**

#### **Climatological Data**

Required climatological data include daily precipitation, daily mean temperature, daily solar radiation, maximum leaf area index, growing season, and evaporative zone depth. Daily precipitation data can be provided by three options. The user may enter each value into the precipitation data file. The second option is to select 5 years of daily precipitation data from a default data set that has data for 102 cities throughout the United States. The third option is to synthetically generate daily precipitation data using a synthetic weather generator available in the program. The program has statistical coefficients describing the daily precipitation at 139 cities throughout the United States. Improvement in the data generation can be obtained by specifying the normal mean monthly precipitation at the landfill site. The synthetic weather generator was adapted from the WGEN model developed by the USDA Agricultural Research Service (20).

Daily mean temperature and daily solar radiation data are synthetically generated by the program after the user selects a location with similar weather from a set of cities having available data. The program contains statistical coefficients describing temperature and solar radiation values at 183 cities throughout the United States. The generation of daily temperature values can be improved by specifying the normal mean monthly temperatures for the landfill site. Similarly, the daily solar radiation values can be improved by specifying the latitude of the landfill site.

When executing the program, guidance is available from a permanent data file for the remaining three climate-related parameters—growing season, maximum leaf area index, and evaporative zone depth. Typically, the growing season is that portion of the year when the mean daily temperature is above about 11°C (53°F). The maximum leaf area index is dependent on climate, soil fertility, cover design, and management practices. Thick layers of fine-grained soils have better fertility and moisture retention than thin layers and coarse-grained soils and, therefore, support better stands of vegetation. The evaporative zone depth is dependent on climate, vegetation, and soil properties. Representative evaporative zone depths for

silty, loamy topsoils are given in the program as a function of location and quantity of vegetation. Typical values would be greater for thick clayey layers while the values for sandy layers would be smaller. In addition, thin layers of materials and the presence of synthetic material near the surface also may restrict the evaporative zone depth.

#### **Soil and Design Data**

The second set of required data consists of a description of each layer of material and a description of the landfill design. Material descriptions can be selected from a default set of material properties or specified individually by the user. The material properties that must be specified by the user are porosity, field capacity, wilting point, and the saturated hydraulic conductivity. Porosity is defined as the volume of voids in a layer of material (or volume of water in a saturated layer) divided by the total volume of the layer. Field capacity is defined as the volume of water remaining in a layer of material after it ceases to drain by gravity divided by the total volume of the layer. It corresponds to the moisture content remaining when the material exerts a soil suction of 1/3 atmospheres. Wilting point is defined as the volume of water remaining in a layer of material after a plant extracts as much water as possible and goes into a permanent wilt, divided by the total volume of the layer. It corresponds to the moisture content remaining when the material exhibits a soil suction of 15 atmospheres. User-specified descriptions are recommended since material properties vary greatly within a given soil classification.

The default set of material descriptions contains properties for 15 soil types ranging from coarse sand to high plasticity clay. These 15 types also include fine sands, loams, silts, and low plasticity clays. These soils also may be specified as compacted, which causes the porosity, field capacity, and saturated hydraulic conductivity to be lower. Compaction is recommended only for the fine-grained materials. In addition to the 15 soils, there are also two descriptions of very low hydraulic conductivity soils suitable for liners and one description of municipal waste with daily cover.

When using either option of describing materials, the user has two options for initializing the moisture content of the materials. The user may specify an initial moisture content ranging from porosity to wilting point. This option is used when the effects of changing moisture storage are important in the water budget. Under the second option, the program initializes the moisture content of the layer to the approximate long-term, steady-state value. This option is used when changes in water storage are unimportant or when the long-term, pseudo-steady-state water budget is desired.

The landfill description consists of the SCS runoff curve number, surface area, runoff area, and a description of the layers including the number of layers, their order and function, and their thickness. Four types of layers, based

on how they function, are used by the model—vertical percolation layers, lateral drainage layers, barrier soil liners, and geomembranes with barrier soil. Vertical percolation layers are layers that serve no purpose other than water storage. The topsoil layer and waste layers are typical examples of this type. Lateral drainage layers are layers designed to promote lateral drainage to a collection system. They typically have very large saturated hydraulic conductivities and are underlain by a sloped liner. Barrier soil liners are layers of low hydraulic conductivity porous material designed to restrict vertical percolation or leakage. A geomembrane with barrier soil is a synthetic membrane underlain by subsoil and is used to restrict vertical percolation and leakage. In addition, the slope and drain spacing are needed for lateral drainage layers and the liner leakage fraction is needed for geomembranes.

### Output Description

The output from the HELP model is a listing of the input data followed by an account of the water budget components in a tabular format. Information on precipitation, surface runoff, evapotranspiration, lateral drainage from each liner/drain system, percolation or leakage through each liner and from the bottom of the profile, moisture storage, snow accumulation, and depth of saturation on the surface of liners is reported. A partial listing of the output for an example application is presented in the next section of this chapter. Simulation results are available at several levels of detail. The cumulative quantity of the water budget components and its variance are tabulated on an average monthly and annual basis for the entire simulation period and optionally on a daily, monthly, and annual basis. In addition, peak daily results during the entire simulation period and final moisture contents of the layers are reported.

### EXAMPLE APPLICATION

This section presents a simulation of the water balance for the closed landfill illustrated in Figure 8-5. The landfill has eight layers—a three-layer cover system, a waste layer, and a four-layer double liner system. The cover consists of a topsoil to support a fair stand of grass, a sand layer to drain excess infiltration, and a clay liner. The waste layer contains lifts of waste and daily cover. The double liner system provides leachate collection and leakage detection. It contains a sand layer for primary leachate collection and a geomembrane for the primary liner. A second sand layer serves as the subsoil for the geomembrane and as the leakage detection or secondary leachate collection layer. The lower liner is a composite liner consisting of both a geomembrane and a clay liner and is considered to be one layer. Many other aspects of the design description required by the HELP model are shown on the schematic.

The example profile can be simulated as having eight or preferably nine layers. The layers are described in the

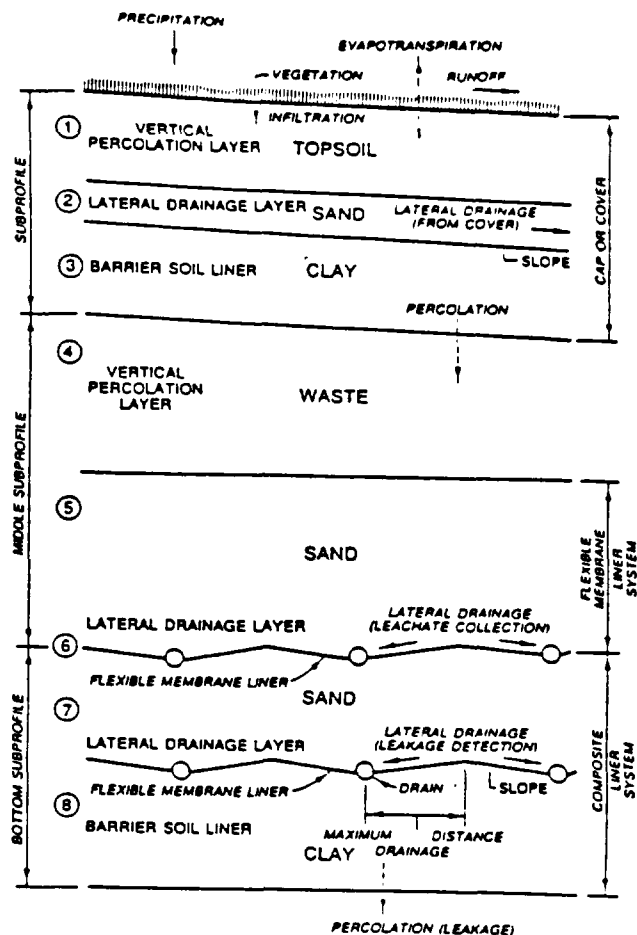

Figure 8-5. Typical hazardous waste landfill profile.

input from top to bottom; therefore, the first layer is the topsoil layer and the last layer is the composite liner. Eight layers are shown on the schematic but nine layers were used in the simulation. The additional layer comes by dividing the waste layer into two layers, the top of which is thick and the lower of which is thin. Dividing thick layers in this manner minimizes discontinuities in the solution. Incontinuities result from use of average moisture contents with greatly different layer thicknesses and occur when the zone of saturation above a liner extends from a thin layer into a thick layer. The materials in the profile were described using the default set of material properties. A completed data form describing the landfill materials and design is shown in Figure 8-6. The data form is available in the user guide (5) and lists the data requirements in the exact form and order that data entry is made in the model.

Climatological input was entered using the default set of rainfall data and the statistical coefficients and default values for synthetic generation of daily temperature and solar radiation values for Philadelphia, Pennsylvania. Values for evaporative zone depth and maximum leaf

DEFAULT SOIL AND DESIGN DATA INPUT

Title: RCRA Cover Seminar  
Philadelphia, Pennsylvania  
29 May 90

Do you want the program to initialize the soil water? No

Number of layers: 9

Layer data:

Layer 1  
 (a) thickness 24 inches  
 (b) layer type 1 (1 or 2)  
 (c) liner leakage fraction (only for layer type 4) — (0 to 1)  
 (d) soil texture number 10 (1 to 20)\*  
 (e) compacted? (only for soil textures 1 to 15) No (Yes or No)  
 (f) initial soil water content (not asked if program is to initialize the soil water or if layer type is 3 or 4) 0.2789 vol/vol  
 (must be between wilting point and porosity)

Layer 2  
 (a) thickness 12 inches  
 (b) layer type 2 (1 to 4)  
 (c) liner leakage fraction (only for layer type 4) — (0 to 1)  
 (d) soil texture number 1 (1 to 20)\*  
 (e) compacted? (only for soil textures 1 to 15) No (Yes or No)  
 (f) initial soil water content (not asked if program is to initialize the soil water or if layer type is 3 or 4) 0.2489 vol/vol  
 (must be between wilting point and porosity)

Layer 3  
 (a) thickness 36 inches  
 (b) layer type 3 (1 to 4)  
 (c) liner leakage fraction (only for layer type 4) — (0 to 1)  
 (d) soil texture number 16 (1 to 20)\*  
 (e) compacted? (only for soil textures 1 to 15) Yes (Yes or No)  
 (f) initial soil water content (not asked if program is to initialize the soil water or if layer type is 3 or 4) 0.5000 vol/vol  
 (must be between wilting point and porosity)

<u>Layer 4</u>	<u>Layer 5</u>	<u>Layer 6</u>
(a) <u>588</u>	(a) <u>12</u>	(a) <u>12</u>
(b) <u>1</u>	(b) <u>1</u>	(b) <u>2</u>
(c) <u>—</u>	(c) <u>—</u>	(c) <u>—</u>
(d) <u>12</u>	(d) <u>12</u>	(d) <u>1</u>
(e) <u>No</u>	(e) <u>No</u>	(e) <u>No</u>
(f) <u>0.2840</u>	(f) <u>0.2880</u>	(f) <u>0.2854</u>

Figure 8-6. Completed data form for landfill materials and design.

<u>Layer 7</u>			<u>Layer 8</u>			<u>Layer 9</u>		
(a)	<u>6</u>	(a)	<u>12</u>	(a)	<u>36</u>			
(b)	<u>4</u>	(b)	<u>2</u>	(b)	<u>4</u>			
(c)	<u>0.00005</u>	(c)	<u>—</u>	(c)	<u>0.00005</u>			
(d)	<u>1</u>	(d)	<u>1</u>	(d)	<u>12</u>			
(e)	<u>1/2</u>	(e)	<u>1/2</u>	(e)	<u>1/2</u>			
(f)	<u>0.47</u>	(f)	<u>0.0479</u>	(f)	<u>0.2777</u>			
<u>Layer 10</u>			<u>Layer 11</u>			<u>Layer 12</u>		
(a)	_____	(a)	_____	(a)	_____			
(b)	_____	(b)	_____	(b)	_____			
(c)	_____	(c)	_____	(c)	_____			
(d)	_____	(d)	_____	(d)	_____			
(e)	_____	(e)	_____	(e)	_____			
(f)	_____	(f)	_____	(f)	_____			

If soil texture number of layer 1 is between 1 and 15, enter:  
 Type of vegetation: Fair (1 to 5)  
 SCS runoff curve number (optional): — (0 to 100)

If the soil texture number of layer 1 is between 16 and 20, enter:  
 SCS runoff curve number: — (0 to 100)

If landfill is open, enter potential runoff fraction: — (0 to 1)

Surface area: 1000000 square feet

Slope of top liner/drain system: 3 percent  
 Distance from crest to drain in top liner/drain system: 500 feet

Slope of second liner/drain system: 5 percent  
 Distance from crest to drain in second liner/drain system: 50 feet

Slope of third liner/drain system: 5 percent  
 Distance from crest to drain in third liner/drain system: 50 feet

Slope of fourth liner/drain system: — percent  
 Distance from crest to drain in fourth liner/drain system: — feet

Initial quantity of snow or ice water on surface (not asked if  
 program is to initialize the soil water): 0 inches

* If soil texture number is 19:	If soil texture number is 20:
(a) wilting point _____ vol/vol	(a) wilting point _____ vol/vol
(b) field capacity _____ vol/vol	(b) field capacity _____ vol/vol
(c) porosity _____ vol/vol	(c) porosity _____ vol/vol
(d) saturated hydraulic conductivity _____ cm/sec	(d) saturated hydraulic conductivity _____ cm/sec

Figure 8-6. (Continued).

area index were selected from the recommended values for a fair stand of grass. A completed data form from the user guide (5) for climatological data input is shown in Figure 8-7.

A partial listing of the output giving all available options, is shown in Figure 8-8. The options include daily, monthly, and annual water balances.

**REFERENCES**

1. U.S. EPA. 1989. Technical guidance document: Final covers on hazardous waste landfills and surface impoundments. EPA/530-SW-89-047.
2. U.S. EPA. 1988. U.S. EPA guide to technical resources for the design of land disposal facilities. EPA Guidance Document: Final Covers on Hazardous Waste Landfills and Surface Impoundments. EPA/530-SW-88-047.
3. Schroeder, P.R., J.M. Morgan, T.M. Walski, and A.C. Gibson. 1984a. Hydrologic Evaluation of Landfill Performance (HELP) Model: Vol. I. User's Guide for Version 1. EPA/530-SW-84-009. U.S. Environmental Protection Agency, Washington, DC. 120 pp.
4. Schroeder, P.R., A.C. Gibson, and M.D. Smolen. 1984b. Hydrologic Evaluation of Landfill Performance (HELP) Model: Vol. II. Documentation for Version 1. EPA/530-SW-84-010. U.S. Environmental Protection Agency, Washington, DC. 256 pp.
5. Schroeder, P.R., R.L. Peyton, and J. M. Sjostrom. 1988a. Hydrologic Evaluation of Landfill Performance (HELP) Model: Vol. III. User's Guide for Version 2. Internal Working Document. USAE Waterways Experiment Station, Vicksburg, MS.
6. Schroeder, P.R., B.M. McEnroe, and R.L. Peyton. 1988b. Hydrologic Evaluation of Landfill Performance (HELP) Model: Vol. IV. Documentation for Version 2. Internal Working Document. USAE Waterways Experiment Station, Vicksburg, MS.
7. Perrier, E.R. and A.C. Gibson. 1980. Hydrologic simulation on solid waste disposal sites. EPA-SW-868. U.S. Environmental Protection Agency, Cincinnati, OH. 111 pp.
8. Schroeder, P.R. and A.C. Gibson. 1982. Supporting documentation for the Hydrologic Simulation Model for Estimating Percolation at Solid Waste Disposal Sites (HSSWDS). Draft Report. U.S. Environmental Protection Agency, Cincinnati, OH. 153 pp.
9. Knisel, W.G., Editor. 1980. CREAMS, a field-scale model for chemical runoff and erosion from agricultural management systems. Vols. I, II, and III. USDA-SEA-AR Conservation Research Report 26. 643 pp.
10. Williams, J.R., A.D. Nicks, and J.G. Arnold. 1985. SWRRB, a simulator for water resources in rural basins. Journal of Hydraulic Engineering. ASCE, Vol. 111, No. 6, pp. 970-986.

CLIMATOLOGICAL DATA INPUT

Default Precipitation Option

Location: Philadelphia, Pennsylvania

Normal Mean Monthly Temperatures in Degrees Fahrenheit (Optional)

Jan. _____	Jul. _____
Feb. _____	Aug. _____
Mar. _____	Sep. _____
Apr. _____	Oct. _____
May _____	Nov. _____
Jun. _____	Dec. _____

Maximum Leaf Area Index: 2

Evaporative Zone Depth in Inches: 24

Figure 8-7. Completed data form for climatological data.

\*\*\*\*\*  
\*\*\*\*\*

RCRA COVER SEMINAR  
PHILADELPHIA, PENNSYLVANIA  
29 MAY 90

\*\*\*\*\*  
\*\*\*\*\*

FAIR GRASS

LAYER 1

-----

VERTICAL PERCOLATION LAYER

THICKNESS	-	24.00 INCHES
POROSITY	-	0.3980 VOL/VOL
FIELD CAPACITY	-	0.2443 VOL/VOL
WILTING POINT	-	0.1361 VOL/VOL
INITIAL SOIL WATER CONTENT	-	0.2739 VOL/VOL
SATURATED HYDRAULIC CONDUCTIVITY	-	0.000360000005 CM/SEC

LAYER 2

-----

LATERAL DRAINAGE LAYER

THICKNESS	-	12.00 INCHES
POROSITY	-	0.4170 VOL/VOL
FIELD CAPACITY	-	0.0454 VOL/VOL
WILTING POINT	-	0.0200 VOL/VOL
INITIAL SOIL WATER CONTENT	-	0.3489 VOL/VOL
SATURATED HYDRAULIC CONDUCTIVITY	-	0.009999999776 CM/SEC
SLOPE	-	3.00 PERCENT
DRAINAGE LENGTH	-	500.0 FEET

LAYER 3

-----

BARRIER SOIL LINER

THICKNESS	-	36.00 INCHES
POROSITY	-	0.4300 VOL/VOL
FIELD CAPACITY	-	0.3663 VOL/VOL
WILTING POINT	-	0.2802 VOL/VOL
INITIAL SOIL WATER CONTENT	-	0.4300 VOL/VOL
SATURATED HYDRAULIC CONDUCTIVITY	-	0.000000100000 CM/SEC

Figure 8-8. Example output.

LAYER 4  
-----  
VERTICAL PERCOLATION LAYER

THICKNESS	-	588.00 INCHES
POROSITY	-	0.5200 VOL/VOL
FIELD CAPACITY	-	0.2942 VOL/VOL
WILTING POINT	-	0.1400 VOL/VOL
INITIAL SOIL WATER CONTENT	-	0.2840 VOL/VOL
SATURATED HYDRAULIC CONDUCTIVITY	-	0.000199999995 CM/SEC

LAYER 5  
-----  
VERTICAL PERCOLATION LAYER

THICKNESS	-	12.00 INCHES
POROSITY	-	0.5200 VOL/VOL
FIELD CAPACITY	-	0.2942 VOL/VOL
WILTING POINT	-	0.1400 VOL/VOL
INITIAL SOIL WATER CONTENT	-	0.2852 VOL/VOL
SATURATED HYDRAULIC CONDUCTIVITY	-	0.000199999995 CM/SEC

LAYER 6  
-----  
LATERAL DRAINAGE LAYER

THICKNESS	-	12.00 INCHES
POROSITY	-	0.4170 VOL/VOL
FIELD CAPACITY	-	0.0454 VOL/VOL
WILTING POINT	-	0.0200 VOL/VOL
INITIAL SOIL WATER CONTENT	-	0.0454 VOL/VOL
SATURATED HYDRAULIC CONDUCTIVITY	-	0.009999999776 CM/SEC
SLOPE	-	5.00 PERCENT
DRAINAGE LENGTH	-	50.0 FEET

LAYER 7  
-----  
BARRIER SOIL LINER WITH FLEXIBLE MEMBRANE LINER

THICKNESS	-	6.00 INCHES
POROSITY	-	0.4170 VOL/VOL
FIELD CAPACITY	-	0.0454 VOL/VOL
WILTING POINT	-	0.0200 VOL/VOL
INITIAL SOIL WATER CONTENT	-	0.4170 VOL/VOL
SATURATED HYDRAULIC CONDUCTIVITY	-	0.009999999776 CM/SEC
LINER LEAKAGE FRACTION	-	0.00005000

Figure 8-8. (Continued).

LAYER 8

-----  
LATERAL DRAINAGE LAYER

THICKNESS	-	12.00 INCHES
POROSITY	-	0.4170 VOL/VOL
FIELD CAPACITY	-	0.0454 VOL/VOL
WILTING POINT	-	0.0200 VOL/VOL
INITIAL SOIL WATER CONTENT	-	0.0478 VOL/VOL
SATURATED HYDRAULIC CONDUCTIVITY	-	0.009999999776 CM/SEC
SLOPE	-	5.00 PERCENT
DRAINAGE LENGTH	-	50.0 FEET

LAYER 9

-----  
BARRIER SOIL LINER WITH FLEXIBLE MEMBRANE LINER

THICKNESS	-	36.00 INCHES
POROSITY	-	0.3777 VOL/VOL
FIELD CAPACITY	-	0.2960 VOL/VOL
WILTING POINT	-	0.2208 VOL/VOL
INITIAL SOIL WATER CONTENT	-	0.3777 VOL/VOL
SATURATED HYDRAULIC CONDUCTIVITY	-	0.000001650000 CM/SEC
LINER LEAKAGE FRACTION	-	0.00005000

GENERAL SIMULATION DATA

-----

SCS RUNOFF CURVE NUMBER	-	85.56
TOTAL AREA OF COVER	-	1000000. SQ FT
EVAPORATIVE ZONE DEPTH	-	24.00 INCHES
UPPER LIMIT VEG. STORAGE	-	9.5520 INCHES
INITIAL VEG. STORAGE	-	6.5736 INCHES
INITIAL SNOW WATER CONTENT	-	0.0000 INCHES
INITIAL TOTAL WATER STORAGE IN SOIL AND WASTE LAYERS	-	213.8724 INCHES

SOIL WATER CONTENT INITIALIZED BY USER.

CLIMATOLOGICAL DATA

-----

DEFAULT RAINFALL WITH SYNTHETIC DAILY TEMPERATURES AND  
SOLAR RADIATION FOR PHILADELPHIA PENNSYLVANIA

MAXIMUM LEAF AREA INDEX	-	2.00
START OF GROWING SEASON (JULIAN DATE)	-	115
END OF GROWING SEASON (JULIAN DATE)	-	296

Figure 8-8. (Continued).



\*\*\*\*\*

MONTHLY TOTALS FOR YEAR 74

	JAN/JUL	FEB/AUG	MAR/SEP	APR/OCT	MAY/NOV	JUN/DEC
PRECIPITATION (INCHES)	2.95 2.08	2.14 3.83	4.91 4.68	2.77 1.93	3.21 0.81	4.43 4.04
RUNOFF (INCHES)	0.007 0.002	0.000 0.231	0.264 0.085	0.089 0.121	0.000 0.000	0.052 0.179
EVAPOTRANSPIRATION (INCHES)	0.978 2.882	1.568 2.725	2.629 4.584	3.257 1.895	3.368 1.116	5.157 1.267
LATERAL DRAINAGE FROM LAYER 2 (INCHES)	0.5736 0.5887	0.5438 0.5094	0.6033 0.4260	0.5951 0.3829	0.6026 0.3204	0.5870 0.2957
PERCOLATION FROM LAYER 3 (INCHES)	0.1476 0.1387	0.1456 0.1329	0.1605 0.1241	0.1793 0.1243	0.1683 0.1169	0.1481 0.1184
LATERAL DRAINAGE FROM LAYER 6 (INCHES)	0.0006 0.0006	0.0005 0.0006	0.0006 0.0006	0.0006 0.0006	0.0006 0.0006	0.0006 0.0006
PERCOLATION FROM LAYER 7 (INCHES)	0.1310 0.1276	0.1169 0.1277	0.1283 0.1237	0.1235 0.1279	0.1275 0.1237	0.1234 0.1279
LATERAL DRAINAGE FROM LAYER 8 (INCHES)	0.1320 0.1275	0.1172 0.1276	0.1284 0.1236	0.1236 0.1278	0.1274 0.1237	0.1233 0.1278
PERCOLATION FROM LAYER 9 (INCHES)	0.0001 0.0001	0.0001 0.0001	0.0001 0.0001	0.0001 0.0001	0.0001 0.0001	0.0001 0.0001

MONTHLY SUMMARIES FOR DAILY HEADS

AVG. DAILY HEAD ON LAYER 3 (INCHES)	15.12 11.24	19.00 9.33	18.83 7.73	27.23 6.40	21.29 5.20	16.06 4.43
STD. DEV. OF DAILY HEAD ON LAYER 3 (INCHES)	4.19 0.74	0.20 0.51	2.32 0.42	2.79 0.37	1.60 0.33	1.63 0.28
AVG. DAILY HEAD ON LAYER 7 (INCHES)	0.00 0.00	0.00 0.00	0.00 0.00	0.00 0.00	0.00 0.00	0.00 0.00
STD. DEV. OF DAILY HEAD ON LAYER 7 (INCHES)	0.00 0.00	0.00 0.00	0.00 0.00	0.00 0.00	0.00 0.00	0.00 0.00

Figure 8-8. (Continued).

AVG. DAILY HEAD ON	0.08	0.07	0.07	0.07	0.07	0.07
LAYER 9 (INCHES)	0.07	0.07	0.07	0.07	0.07	0.07
STD. DEV. OF DAILY HEAD	0.00	0.00	0.00	0.00	0.00	0.00
ON LAYER 9 (INCHES)	0.00	0.00	0.00	0.00	0.00	0.00

\*\*\*\*\*

\*\*\*\*\*

ANNUAL TOTALS FOR YEAR 74

	(INCHES)	(CU. FT.)	PERCENT
	-----	-----	-----
PRECIPITATION	37.78	3148334.	100.00
RUNOFF	1.029	85764.	2.72
EVAPOTRANSPIRATION	31.425	2618786.	83.18
LATERAL DRAINAGE FROM LAYER 2	6.0285	502377.	15.96
PERCOLATION FROM LAYER 3	1.7047	142062.	4.51
LATERAL DRAINAGE FROM LAYER 6	0.0070	586.	0.02
PERCOLATION FROM LAYER 7	1.5090	125754.	3.99
LATERAL DRAINAGE FROM LAYER 8	1.5097	125812.	4.00
PERCOLATION FROM LAYER 9	0.0010	85.	0.00
CHANGE IN WATER STORAGE	-2.221	-185075.	-5.88
SOIL WATER AT START OF YEAR	213.87	17822700.	
SOIL WATER AT END OF YEAR	211.65	17637624.	
SNOW WATER AT START OF YEAR	0.00	0.	
SNOW WATER AT END OF YEAR	0.00	0.	
ANNUAL WATER BUDGET BALANCE	0.00	-1.	0.00

\*\*\*\*\*

Figure 8-8. (Continued).

\*\*\*\*\*  
 AVERAGE MONTHLY VALUES IN INCHES FOR YEARS 74 THROUGH 78  
 -----

	JAN/JUL	FEB/AUG	MAR/SEP	APR/OCT	MAY/NOV	JUN/DEC
<b>PRECIPITATION</b>						
-----						
TOTALS	4.59 3.67	1.88 4.46	4.09 4.17	3.03 2.76	3.85 2.68	4.50 3.99
STD. DEVIATIONS	2.53 1.95	0.66 2.49	1.00 2.07	1.51 1.21	2.03 2.63	2.17 1.78
<b>RUNOFF</b>						
-----						
TOTALS	1.478 0.414	0.053 0.212	0.290 0.302	0.154 0.047	0.156 0.384	0.170 0.339
STD. DEVIATIONS	3.008 0.556	0.066 0.195	0.181 0.596	0.216 0.050	0.254 0.706	0.244 0.370
<b>EVAPOTRANSPIRATION</b>						
-----						
TOTALS	0.973 4.199	1.485 3.565	2.701 2.998	3.019 2.027	4.110 1.361	4.833 1.015
STD. DEVIATIONS	0.246 1.766	0.220 1.593	0.089 1.536	0.331 0.836	1.020 0.430	1.223 0.195
<b>LATERAL DRAINAGE FROM LAYER 2</b>						
-----						
TOTALS	0.4856 0.5247	0.4957 0.4530	0.5418 0.3789	0.5476 0.3728	0.5656 0.3589	0.5414 0.4268
STD. DEVIATIONS	0.1797 0.1150	0.1440 0.1025	0.1524 0.0900	0.0954 0.1297	0.0847 0.1225	0.0987 0.1686
<b>PERCOLATION FROM LAYER 3</b>						
-----						
TOTALS	0.1548 0.1344	0.1502 0.1291	0.1639 0.1209	0.1623 0.1236	0.1567 0.1204	0.1427 0.1331
STD. DEVIATIONS	0.0391 0.0082	0.0353 0.0069	0.0286 0.0060	0.0245 0.0089	0.0182 0.0101	0.0149 0.0199
<b>LATERAL DRAINAGE FROM LAYER 6</b>						
-----						
TOTALS	0.0006 0.0006	0.0006 0.0006	0.0006 0.0006	0.0006 0.0006	0.0006 0.0006	0.0006 0.0006

Figure 8-8. (Continued).

STD. DEVIATIONS	0.0000	0.0000	0.0000	0.0000	0.0000	0.0000
	0.0000	0.0000	0.0000	0.0000	0.0000	0.0000
PERCOLATION FROM LAYER 7						
-----						
TOTALS	0.1301	0.1181	0.1298	0.1257	0.1300	0.1260
	0.1304	0.1305	0.1264	0.1306	0.1264	0.1306
STD. DEVIATIONS	0.0015	0.0023	0.0017	0.0018	0.0020	0.0021
	0.0022	0.0022	0.0021	0.0022	0.0021	0.0021
LATERAL DRAINAGE FROM LAYER 8						
-----						
TOTALS	0.1302	0.1181	0.1297	0.1256	0.1299	0.1259
	0.1303	0.1304	0.1263	0.1305	0.1263	0.1305
STD. DEVIATIONS	0.0017	0.0022	0.0016	0.0018	0.0020	0.0020
	0.0022	0.0022	0.0021	0.0022	0.0021	0.0022
PERCOLATION FROM LAYER 9						
-----						
TOTALS	0.0001	0.0001	0.0001	0.0001	0.0001	0.0001
	0.0001	0.0001	0.0001	0.0001	0.0001	0.0001
STD. DEVIATIONS	0.0000	0.0000	0.0000	0.0000	0.0000	0.0000
	0.0000	0.0000	0.0000	0.0000	0.0000	0.0000

\*\*\*\*\*

\*\*\*\*\*  
 AVERAGE ANNUAL TOTALS & (STD. DEVIATIONS) FOR YEARS 74 THROUGH 78

	(INCHES)	(CU. FT.)	PERCENT
	-----	-----	-----
PRECIPITATION	43.67 ( 7.930)	3639167.	100.00
RUNOFF	3.998 ( 3.685)	333190.	9.16
EVAPOTRANSPIRATION	32.287 ( 2.428)	2690580.	73.93
LATERAL DRAINAGE FROM LAYER 2	5.6928 ( 1.0786)	474402.	13.04
PERCOLATION FROM LAYER 3	1.6920 ( 0.1508)	140998.	3.87
LATERAL DRAINAGE FROM LAYER 6	0.0073 ( 0.0002)	604.	0.02
PERCOLATION FROM LAYER 7	1.5347 ( 0.0220)	127890.	3.51

Figure 8-8. (Continued).

LATERAL DRAINAGE FROM LAYER 8	1.5338 ( 0.0214)	127814.	3.51
PERCOLATION FROM LAYER 9	0.0010 ( 0.0000)	86.	0.00
CHANGE IN WATER STORAGE	0.150 ( 5.089)	12491.	0.34
*****			
*****			
PEAK DAILY VALUES FOR YEARS 74 THROUGH 78			
		(INCHES)	(CU. FT.)
		-----	-----
PRECIPITATION		3.99	332500.0
RUNOFF		2.341	195074.9
LATERAL DRAINAGE FROM LAYER 2		0.0209	1744.7
PERCOLATION FROM LAYER 3		0.0068	567.3
HEAD ON LAYER 3		36.1	
LATERAL DRAINAGE FROM LAYER 6		0.0000	2.5
PERCOLATION FROM LAYER 7		0.0043	359.0
HEAD ON LAYER 7		0.0	
LATERAL DRAINAGE FROM LAYER 8		0.0045	371.3
PERCOLATION FROM LAYER 9		0.0000	0.2
HEAD ON LAYER 9		0.1	
SNOW WATER		4.09	340770.0
MAXIMUM VEG. SOIL WATER (VOL/VOL)		0.3980	
MINIMUM VEG. SOIL WATER (VOL/VOL)		0.1359	
*****			

Figure 8-8. (Continued).

\*\*\*\*\*

FINAL WATER STORAGE AT END OF YEAR 78

LAYER	(INCHES)	(VOL/VOL)
1	6.57	0.2739
2	4.19	0.3488
3	15.48	0.4300
4	167.74	0.2853
5	3.42	0.2853
6	0.55	0.0454
7	2.50	0.4170
8	0.57	0.0478
9	13.60	0.3777
SNOW WATER	0.00	

\*\*\*\*\*  
\*\*\*\*\*

Figure 8-8. (Continued).

11. USDA, Soil Conservation Service. 1972. Section 4, Hydrology. In: National Engineering Handbook, U.S. Government Printing Office, Washington, DC. 631 pp.
12. Horton, R.E. 1919. Rainfall Interception. Monthly Weather Review, U.S. Weather Bureau. Vol. 47, No. 9, pp. 603-623.
13. Ritchie, J.T. 1972. A model for predicting evaporation from a row crop with incomplete cover. Water Resources Research. Vol. 8, No. 5, pp. 1204-1213.
14. Brooks, R.H. and A.T. Corey. 1964. Hydraulic properties of porous media. Hydrology Paper No. 3, Colorado State University. 27 pp.
15. Campbell, G.S. 1974. A simple method for determining unsaturated hydraulic conductivity from moisture retention data. Soil Science. Vol. 117, No. 6, pp. 311-314.
16. Brown, K.W., J.C. Thomas, R.L. Lytton, P. Jayawikrama, and S.C. Bahrt. 1987. Quantification of Leak Rates Through Holes in Landfill Liners. EPA/600/S2-87-062. U.S. Environmental Protection Agency, Cincinnati, OH. 151 pp.
17. Giroud, J.P. and R. Bonaparte. 1989a. Leakage through liners constructed with geomembranes, Part I: Geomembrane liners. Geotextiles and Geomembranes. Vol. 8, No. 1, pp. 27-67.
18. Giroud, J.P. and R. Bonaparte. 1989b. Leakage through liners constructed with geomembranes, Part II: Composite liners. Geotextiles and Geomembranes. Vol. 8, No. 2, pp. 71-111.
19. Giroud, J.P., A. Khatami, and K. Badu-Tweneboah. 1989c. Evaluation of the rate of leakage through composite liners. Geotextiles and Geomembranes. Vol. 8, No. 4, pp. 337-340.
20. Richardson, C.W. and D.A. Wright. 1984. WGEN: a model for generating daily weather variables. ARS-8, Agricultural Research Service, USDA. 83 pp.

---

## CHAPTER 9

### SENSITIVITY ANALYSIS OF HELP MODEL PARAMETERS

#### INTRODUCTION

This chapter examines the sensitivity of landfill water balance to numerous landfill design variables using the Hydrologic Evaluation of Landfill Performance (HELP) model. This information is useful in a variety of ways. It can aid the design engineer in selecting preliminary design alternatives for municipal or hazardous waste landfills. It can serve as a basis for regulatory agencies to establish and evaluate technical guidelines. It can also provide additional insight on the importance and interaction of specific design variables on the water balance. Finally, it can assist in evaluating the suitability of methodologies used in the computer model. The analyses include examination of both cover systems and lateral drainage/liner systems (1). The complete list of design characteristics examined is given in Table 9-1.

The analysis of landfill cover design is divided into two parts. First, water balance results are compared for different general design conditions such as climate (location), topsoil and vegetative characteristics, and cover

design. Then, the effects resulting from changes in specific characteristics of the vegetative layer, such as runoff curve number, evaporative depth, and moisture retention properties, are examined. The water balance components examined in this chapter are surface runoff, evapotranspiration, lateral subsurface drainage to collection systems, and vertical percolation through the soil liner.

The analysis of liner systems examines the effects of slope, drain spacing, saturated hydraulic conductivity, and geomembrane leakage characteristics on leachate collection and leakage through liners. Two types of vertical inflows to the drain layer are considered. First, an inflow rate of 127 cm/yr (50 in./yr) was used to represent infiltration at an open landfill. This inflow was distributed in time according to actual rainfall patterns at Shreveport, Louisiana. Second, an inflow rate of 20 cm/yr (8 in./yr) uniformly distributed in time was used to represent infiltration at a covered landfill.

In the discussion that follows, the effects of the saturated hydraulic conductivities of the drain layer and liner are first investigated by holding the slope and drainage length constant. Then, the slope and drainage length are examined by holding the hydraulic conductivities constant. In all cases, the thickness of the lateral drainage layer was greater than the maximum head, and the thickness of the soil liner was 61 cm (24 in.).

**Table 9-1. Parameters Selected for Sensitivity Analysis**

---

#### Typical Cover Systems

- Quantity of vegetation
- Cover soil thickness
- Topsoil type
- Use of lateral drainage layer
- Geographical location or climate

#### Vegetative Layer

- SCS runoff curve number
- Evaporative depth
- Drainable porosity
- Plant available water
- Municipal vs. hazardous waste cover design

#### Analysis of Percolation and Drainage Design

- Hydraulic conductivity of barrier soil layer
  - Hydraulic conductivity of lateral drainage layer
  - Geomembrane leakage factor
  - Liner type (clay, geomembrane, or composite)
  - Slope of lateral drainage layer
  - Drainage length
  - Double liner system design
- 

#### COMPARISON OF TYPICAL COVER SYSTEMS

##### *Design Parameters*

Three locations were studied to determine the effect of various climatological regimes on cover performance—Santa Maria, California; Schenectady, New York; and Shreveport, Louisiana. These locations represent a wide range in levels of precipitation, temperature, and solar radiation as summarized in Table 9-2. Default values for precipitation, temperature, solar radiation, and leaf area index are stored in the HELP model for each site and were used for the sensitivity analysis simulations. The period of record stored in the HELP model for daily precipitation is 1974 through 1978.

Two cover designs were examined as shown in Figure 9-1. One is typical of some newer landfills where 0.61 m (2 ft)

**Table 9-2. Climatological Regimes**

Climatological Variable	Location		
	Santa Maria, CA	Schenectady, NY	Shreveport, LA
<b>Precipitation<sup>1</sup></b>			
Mean annual (in.)	14	48	44
Mean winter (Nov-Apr) (in.)	12	19	22
Mean summer (May-Oct) (in.)	2	29	22
<b>Temperature</b>			
Mean annual (°F)	57	49	66
Mean Jan (°F)	51	23	47
Mean July (°F)	62	73	83
Days with minimum below 32°F	24	129	37
<b>Solar radiation</b>			
Mean daily (langleys)	450	290	410

<sup>1</sup>These mean values are for the period simulated by the HELP model in this section, 1974-1978.

of topsoil overlies a 0.31-m (1-ft) thick lateral drainage layer having a saturated hydraulic conductivity of  $3 \times 10^{-2}$  cm/sec, a slope of 0.01 m/m (0.03 ft/ft) and a maximum drainage length of 61 m (200 ft). The drainage layer is underlain by a 0.61-m (2-ft) thick soil liner having a saturated hydraulic conductivity of  $1 \times 10^{-7}$  cm/sec. The other design is typical of older municipal sanitary landfills where a topsoil layer overlies a 0.61-m (2-ft) thick soil liner having a saturated hydraulic conductivity of  $1 \times 10^{-5}$  cm/sec.

Two types of topsoil were considered in the cover designs: sandy loam and silty, clayey loam. The sandy loam characteristics were those of the HELP model default soil texture 6, which represents Unified Soil Classification System (USCS) soil class SM and U.S. Department of Agriculture (USDA) soil class SL. The silty, clayey loam characteristics were those of the HELP model default soil texture 12, which represents USCS soil class CL and USDA soil class SICL. The topsoil-type designation was used to select soil porosity, field capacity, wilting point, and hydraulic conductivity, besides influencing the selection of the runoff curve number. In addition to two types of topsoil, two thickness of topsoil were examined—46 cm (18 in.) and 91 cm (36 in.).

The vegetative cover was designated as being either a good stand of grass or a poor stand of grass. This selection dictated the values for leaf area index, evaporative depth, and runoff curve number, and influenced the value used for the saturated hydraulic conductivity of the topsoil. For a given vegetative cover and topsoil material, the runoff curve number was obtained from the HELP Model User's Guide (2). These numbers were 60 for good grass on sandy loam; 80 for poor grass on sandy

loam; 81 for good grass on silty, clayey loam; and 92 for poor grass on silty, clayey loam. These curve numbers are in agreement with values obtained from Section 4, Hydrology, National Engineering Handbook (3). The depth of the evaporative zone was chosen as 18 cm (7 in.) for poor grass and 36 cm (14 in.) for good grass.

### Results

Figures 9-2 and 9-3 summarize the results obtained in the general sensitivity analysis performed on the cover systems, respectively, with and without lateral drainage. The height of each bar segment represents the corresponding mean annual value of water balance component in inches which is given next to each bar segment. The results provide a comparison of the effect of varying quantity of vegetation, cover design, topsoil type, topsoil thickness, and climatological regime.

### Effects of Vegetation

Two levels of vegetation were examined—a poor stand of grass and a good stand of grass; the latter represents three times the quantity of vegetation as that of the former. Table 9-3 presents the water balance results for both cover systems at all three sites as a function of level of vegetation. The results are given in units of percent of the precipitation during the simulation period.

Vegetation reduces surface runoff and increases evapotranspiration. Evapotranspiration is greater because the plant demand for moisture and a greater quantity of water is available for evapotranspiration due to greater infiltration and a greater evaporative zone. Runoff is less because vegetation increases the minimum infiltration rate, drying rate, interception, and surface roughness, which results in a decrease in the runoff curve

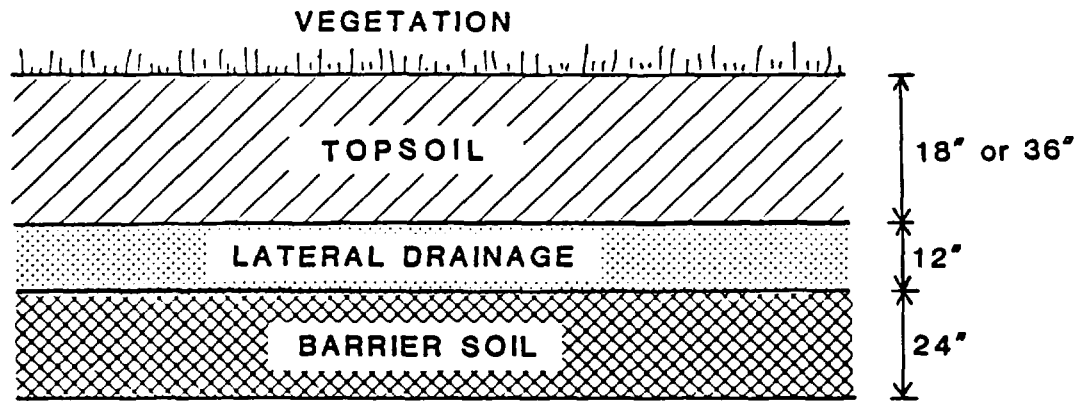

a) Three Layer Landfill Cover Design

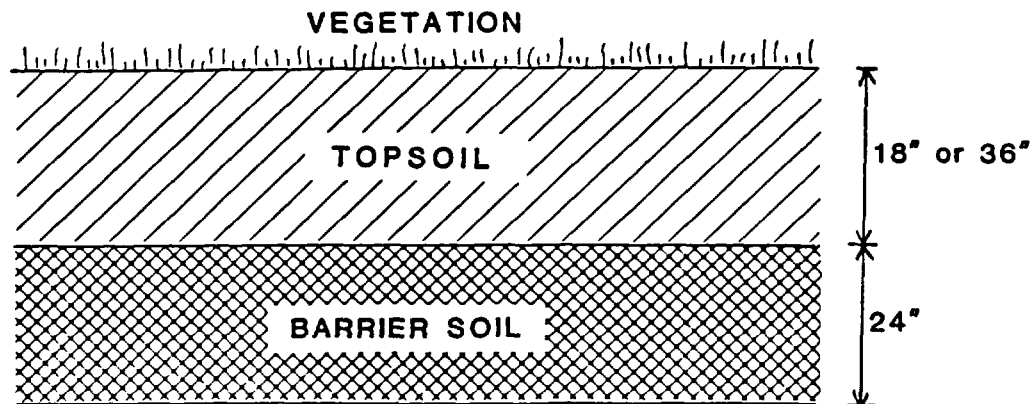

b) Two Layer Landfill Cover Design

Figure 9-1. Cover designs for sensitivity analysis.

number. The influence of surface vegetation on the volume of lateral drainage and percolation or leakage from the cover is varied. However, the quantity of vegetation tends to have very little effect on the percolation or leakage through the cover system. For the cover with lateral drainage, the increase in infiltration with good grass was greater than the increase in evapotranspiration, resulting in a larger volume of lateral drainage and a negligible change in percolation. For the cover without lateral drainage, the increase in infiltration yielded high heads or depths of saturation above the liner that permitted greater evapotranspiration by maintaining higher moisture contents in the evaporative zone. Consequently, the increase in evapotranspiration was greater than the increase in infiltration. This resulted in a trend toward a small decrease in percolation for a higher level of vegetation. The opposite trend may occur for vegetative layers having lower saturated hydraulic conductivities

and higher plant available water capacities. The results were similar at all three sites despite quite different climates. In summary, vegetation decreases runoff and increases evapotranspiration but tends to have little effect on the water balance. The magnitude of the effects is design dependent and to a lesser degree climate dependent. The main function of vegetation is to control erosion.

#### Effects of Topsoil Thickness

Two topsoil thicknesses were examined—46 cm (18 in.) and 91 cm (36 in.). Table 9-4 presents the water balance results for the two-layer cover system as a function of topsoil thickness at all three sites. The results are given in units of percent of the precipitation during the simulation period. The cover system with lateral drainage was not used in this analysis because lateral drainage would negate the effects by preventing or minimizing the in-

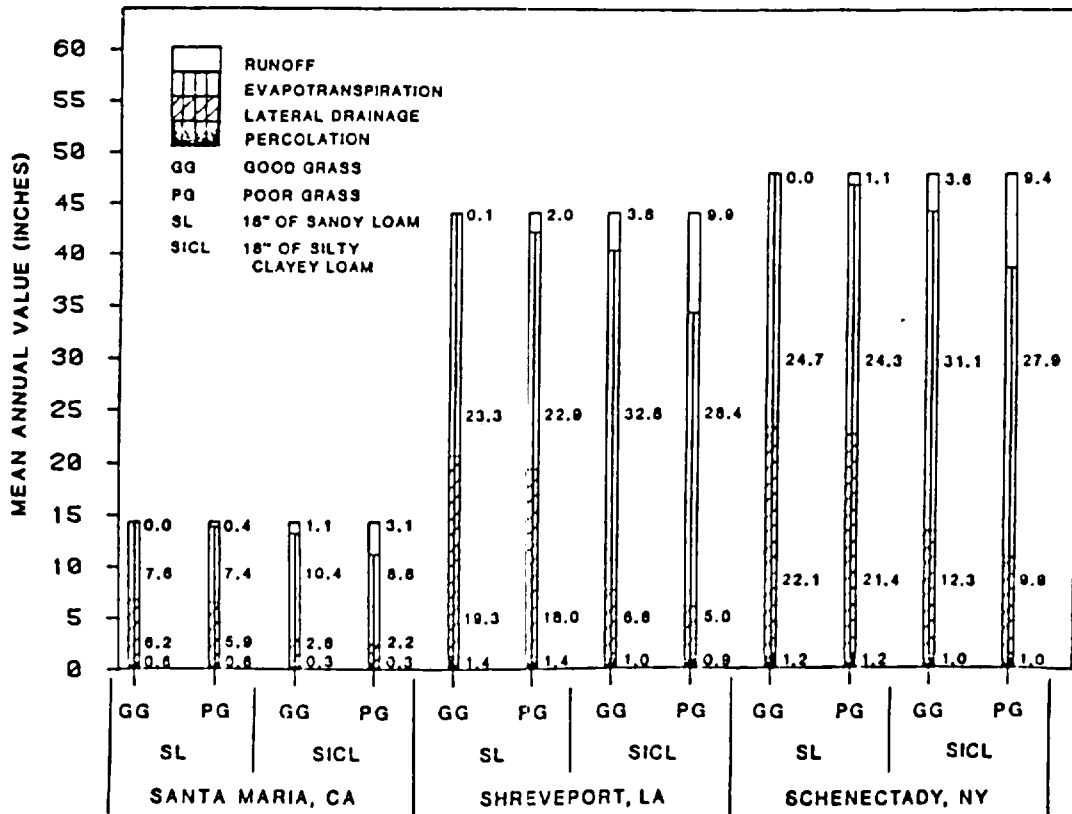

Figure 9-2. Bar graph for three-layer cover design showing effect of surface vegetation, topsoil type, and location.

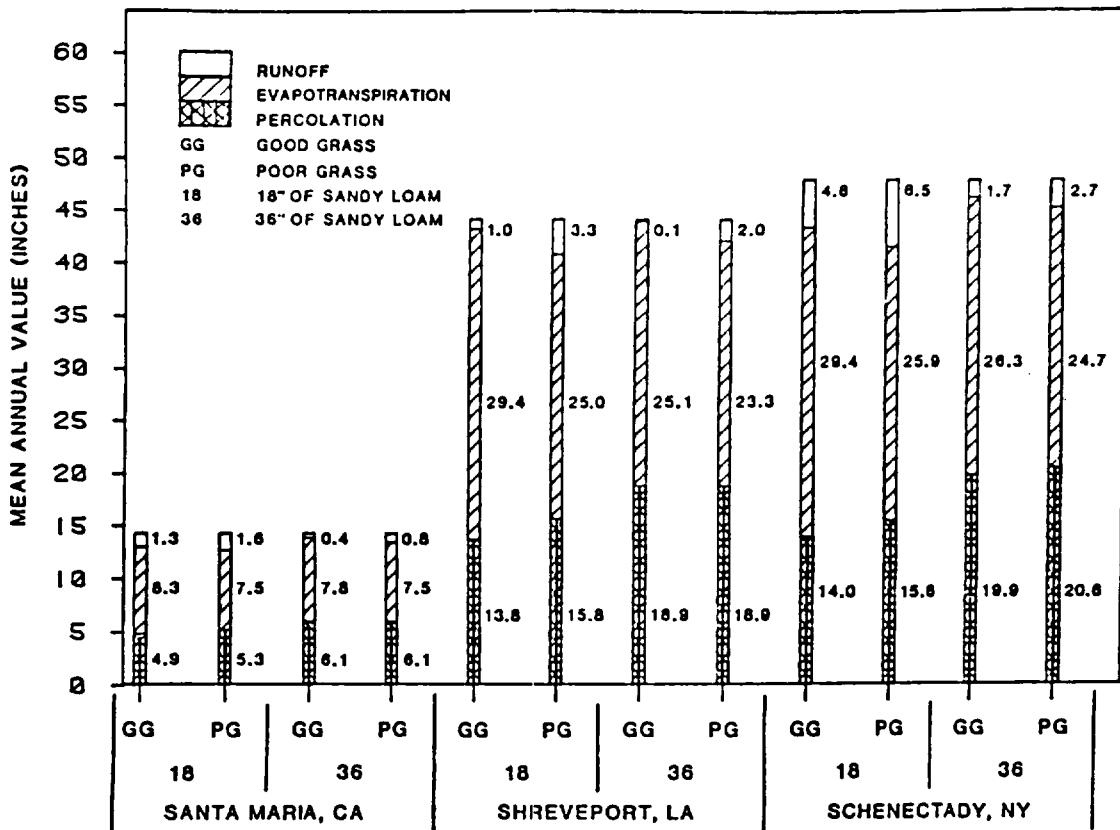

Figure 9-3. Bar graph for two-layer cover design showing effect of topsoil depth, surface vegetation, and location.

**Table 9-3. Effects of Climate and Vegetation**

**81 cm (36 in.) of Sandy Loam Topsoil  
61 cm (24 in.) of  $1 \times 10^{-6}$  cm/sec Clay Liner**

	Locations		
	CA	LA (Percent of Precipitation)	NY
Poor grass			
Runoff	5.6	4.6	5.5
Evapotranspiration	51.8	53.0	52.1
Percolation	42.6	42.4	42.4
Good grass			
Runoff	3.1	0.2	3.5
Evapotranspiration	55.0	57.2	55.3
Percolation	42.9	42.6	41.2

**46 cm (18 in.) of Sandy Loam Topsoil  
31 cm (12 in.) of 0.03 cm/sec Sand with 61 m (200 ft) Drain Length at 3% Slope  
61 cm (24 in.) of  $1 \times 10^{-7}$  cm/sec Clay Liner**

	Locations		
	CA	LA (Percent of Precipitation)	NY
Poor grass			
Runoff	3.0	4.4	2.2
Evapotranspiration	51.6	51.9	50.3
Lateral drainage	41.2	40.6	44.0
Percolation	4.2	3.1	2.5
Good grass			
Runoff	0.0	0.2	0.0
Evapotranspiration	52.6	53.0	51.0
Lateral drainage	43.2	43.7	45.5
Percolation	4.2	3.1	2.5

**Table 9-4. Effects of Climate and Topsoil Thickness**

**Sandy Loam Topsoil with a Poor Stand of Grass  
61 cm (24 in.) of  $1 \times 10^{-6}$  cm/sec Clay Liner**

	Locations		
	CA	LA (Percent of Precipitation)	NY
46 cm (18 in.) of topsoil			
Runoff	11.2	7.5	13.4
Evapotranspiration	51.9	56.9	54.5
Percolation	36.9	35.6	32.1
91 cm (36 in.) of topsoil			
Runoff	5.6	4.6	5.5
Evapotranspiration	51.8	53.0	52.1
Percolation	42.6	42.4	42.4

trusion of the saturated zone above the liner into the evaporative zone.

Significant differences existed between the 46- and 91-cm (18- and 36-in.) topsoil depth simulations in the absence of lateral drainage. The effects were similar at all three sites. Runoff and evapotranspiration were greater for the shallower depth to the liner, indicating that the head above the barrier soil layer maintained higher moisture contents in the evaporative zone. The percolation was subsequently less than the cases with greater topsoil thickness. The 91-cm (36-in.) depth to the liner permits larger heads and longer sustaining heads since a greater thickness of material below the evaporative zone is free from abstraction of water by evapotranspiration. The larger heads provide a greater pressure gradient to increase the leakage rate through the cover system.

In general, the effects of topsoil thickness vary greatly as the thickness increases from several inches to several feet. Throughout the transition, the quantity of runoff should continue to decrease until the depth to the liner becomes sufficiently great so as to prevent the zone of saturation to ever climb into the evaporative zone. Similarly, the percolation through the liner should continue to increase until there is no interaction between the saturation zone and the evaporative zone. The evapotranspiration is expected to increase initially as the available storage in the evaporative zone increases, i.e., until the depth to the liner equals the maximum depth that evapotranspiration can reach. At greater depths the evapotranspiration should continue to decrease until the depth to the liner is sufficient to prevent any further interactions between the evaporative and saturation zones.

While percolation increases with topsoil thickness given identical properties for all layers in the cover system, adequate thickness must be provided in a design to ensure the integrity of the cover system. A small topsoil

thickness would not provide adequate water storage to support vegetation, maintain soil stability, and control erosion. Similarly, a shallow depth to the liner would promote desiccation or freezing of the liner, which may greatly increase its permeability and, therefore, the percolation.

### Effects of Topsoil Type

Two topsoil types were examined—sandy loam and silty, clayey loam. Table 9-5 presents the water balance results for the three-layer cover system as a function of topsoil type at all three sites. The results are given in units of percent of the precipitation during the simulation period. The cover system without lateral drainage was not used in this analysis because the intrusion of the saturated zone above the liner into the evaporative zone would decrease the magnitude of the effects.

The results show that the clayey topsoil significantly increased both runoff and evapotranspiration, which in turn greatly decreased lateral drainage and percolation. The results were similar at all three sites. Runoff increased from about 3 percent to 20 percent of the precipitation, due primarily to the larger runoff curve number selected for the clayey soil based on its lower minimum infiltration rate. Evapotranspiration increased approximately from 51 percent to 61 percent of precipitation, due to the lower hydraulic conductivity of the clayey soil and, more importantly, the larger plant available water capacity (field capacity minus wilting point). The lower hydraulic conductivity of the clayey soil slowed the drainage rate, maintaining moisture contents above field capacity for longer periods of time and allowing greater evapotranspiration. The larger plant available water capacity of the clayey soil provided a larger moisture reservoir available for evapotranspiration after gravity drainage ceased. The lateral drainage was reduced from about 42 percent to 16 percent of the precipitation and

**Table 9-5. Effects of Climate and Topsoil Types**

46 cm (18 in.) of Topsoil with a Poor Stand of Grass  
 31 cm (12 in.) of 0.03 cm/sec Sand with 61 m (200 ft) Drain Length at 3% Slope  
 61 cm (24 in.) of  $1 \times 10^{-7}$  cm/sec Clay Liner

	Locations		
	CA	LA (Percent of Precipitation)	NY
<b>Sandy loam</b>			
Runoff	3.0	4.4	2.2
Evapotranspiration	51.6	51.9	50.3
Lateral drainage	41.2	40.6	44.0
Percolation	4.2	3.1	2.5
<b>Silty, clayey loam</b>			
Runoff	21.6	22.3	19.2
Evapotranspiration	61.2	64.4	58.6
Lateral drainage	15.0	11.3	20.3
Percolation	2.2	2.0	1.9

the percolation was reduced from about 3 percent to 2 percent of precipitation.

#### **Use of Lateral Drainage Layer**

Direct comparison of the use of a lateral drainage layer was not made since different liner systems were used in the two cover designs. The impact of the use of a lateral drainage layer was explained briefly above. In general, the use of a lateral drainage layer would be expected to decrease the height of the saturation zone above the liner by draining some of the infiltrated water from the cover system. As such, percolation through clay liners would decrease slightly. In addition, runoff and evapotranspiration also would tend to decrease but the magnitude of the change would be design dependent. Topsoil thickness, topsoil type, vegetation, and climate would have impacts.

#### **Effects of Climate**

The effects of climate were examined in each of the previous sections. As shown in Figures 9-2 and 9-3, climate affects the absolute magnitude, in inches, of the water budget components. However, Tables 9-3, 9-4, and 9-5 show that climate has a much smaller effect on the relative magnitude of the water budget components in terms of percent of the precipitation. The relative proportions of the water budget components are primarily design dependent while the magnitudes are strongly dependent on the magnitude of the precipitation.

The effect of temperature and solar radiation can be determined by comparing the results for the Louisiana and New York sites. These two sites have similar annual rainfall, although the New York site had somewhat higher annual and summer rainfall. The higher temperature and solar radiation in Louisiana produced about an inch or two more evapotranspiration despite the larger quantity of rainfall in New York. Consequently, the lateral drainage tended to be slightly less at the Louisiana site. However, these differences are much smaller than the differences caused by changes in designs.

#### **Vegetative Layer Properties**

The effects of vegetative layer properties on the water balance of two cover systems are presented below. The vegetative layer properties examined are runoff curve number, evaporative depth, drainable porosity, and plant available water capacity. Vegetated cover designs with and without lateral drainage were used in the analyses; the vegetation was assumed to be a fair stand of grass. The thickness of the vegetative layer was 46 cm (18 in.) in both designs. The simulations were performed using climatic data for Santa Maria, California, and Shreveport, Louisiana, and topsoil properties typical of sandy loam and silty, clayey loam. Tables 9-6 and 9-7 summarize the parameter combinations examined under this part of the sensitivity analysis study and present the results of the simulations as percentage of precipitation.

#### **Effects of SCS Runoff Curve Number**

The SCS runoff curve number was varied from 65 to 90 for the sandy loam and from 75 to 95 for the silty, clayey loam. The range of curve number was selected to include values representative of the entire range of possible slopes and land management practices used at landfills. The depth of the evaporative zone was 25 cm (10 in.) in all cases. Simulations for the three-layer cover design were performed for both soil types, whereas simulations for the two-layer cover design were performed only for sandy loam. The results are presented in Table 9-6.

An increase in runoff curve number produced an increase in runoff and a decrease in evapotranspiration, lateral drainage, and percolation. The percent increase in runoff was less for the two-layer cover design than for the three-layer cover design. This result was due to the higher average moisture content in the topsoil layer of the two-layer design caused by the restriction to vertical flow imposed by the soil liner in the absence of lateral drainage. This limited the infiltration capacity of the topsoil, causing more frequent saturation of the topsoil and, therefore, more runoff. Thus, runoff volume at low curve numbers was higher for the two-layer cover compared to the three-layer cover. This effect was not as great at high curve numbers because infiltration for both designs was significantly reduced by the curve number itself rather than saturated conditions.

The effects of location or climate on runoff are difficult to discern from the results; however, results in terms of percent of the precipitation did not differ greatly between the two sites. For example, in comparing runoff from Santa Maria and Shreveport, a smaller percentage of precipitation could be expected to drain from the surface as runoff in Santa Maria due to the higher evaporative demand combined with lower total precipitation and longer periods of time between storms. This effect is seen in the data for the three-layer design, but the difference is not as large as may have been expected. Only small differences occur largely because the majority of the rainfall at Santa Maria occurs during the winter when the evaporative demand is the lowest. In addition, several unusually large storms occurred at Santa Maria that yielded unusually large runoff. However, for simulations of the two-layer design with low curve numbers, the influence of the two large storms in Santa Maria caused the runoff percentage to exceed that in Shreveport. This would not be the case if the two storms were excluded.

Summarizing the curve number effects, increasing the curve number directly causes an increase in runoff and a decrease in infiltration. The majority of the decrease in infiltration is reflected as decreases in lateral drainage and evapotranspiration. The decrease in leakage through the cover system is generally small. Changes in slope, vegetation, and land management practices yield

only small changes in runoff for soil types and conditions with curve numbers below 75. The climate, design, and topsoil characteristics affect the volume of runoff for a given curve number. The nature of the effects is closely tied to the potential for evapotranspiration, vertical drainage from the topsoil, and lateral drainage.

### Effects of Evaporative Depth

Evaporative depth as defined by its use in the HELP model is the thickness of the evapotranspiration zone, the maximum depth from which water can be extracted to satisfy evapotranspiration demand. This depth is a function of soil properties, vegetation, climate, and design. The evaporative depth was varied from 10 to 46 cm (4 to 18 in.) for both sandy loam and silty, clayey loam. The runoff curve number was 75 for the sandy loam and 85 for the silty, clayey loam. Simulations for the three-layer cover design were performed for both soil types, whereas simulations for the two-layer cover design were performed only for sandy loam. The results are presented in Table 9-6.

Evapotranspiration increased with increasing evaporative depth while lateral drainage and percolation decreased; the effect on runoff varied. The interrelationship between these variables is complex and depends on many factors. The increase in evaporative depth allows evapotranspiration to deplete soil moisture from greater depths, generally increasing the total volume of evapotranspiration. However, since the total evapotranspiration demand remains constant, a smaller volume of water depletion occurs per unit depth. Consequently, the average moisture content throughout the evaporative zone would be higher, resulting in a higher runoff curve number and, therefore, larger runoff. However, when the time period between storms is sufficiently long, evapotranspiration demand is able to deplete soil moisture to equal levels with either small or large evaporative depths. In this case, runoff volume could decrease with increasing evaporative depth since antecedent moisture conditions would remain the same and the increased storage volume in the deeper evaporative zone would increase the infiltration capacity.

The effect of evaporative depth on the volume of lateral drainage and percolation is directly related to the composite effect on evapotranspiration and runoff. In the examples chosen for Table 9-6, the increase in evapotranspiration with increased evaporative depth was greater than any increase in infiltration; therefore, lateral drainage and percolation always decreased.

An increase in evaporative depth caused an increase in infiltration for the two-layer cover compared to a slight decrease for the three-layer cover. This difference relates to the different mechanisms controlling infiltration in these two cases. For the two-layer cover, the hydraulic conductivity of the clay liner was much less than the sandy loam topsoil. Therefore, infiltration tended to

saturate the topsoil layer, and the total volume of infiltration was dependent primarily on the volume of storage available in this layer. A larger evaporative depth increased the potential for a larger volume of available storage and thus for more infiltration. For the three-layer cover, the lateral drainage layer generally maintained a free drainage condition at the topsoil/lateral drainage layer interface. Infiltration was then controlled primarily by the hydraulic conductivity of the topsoil and the available storage in the top segment of the subprofile. As explained above, this condition could result in either an increase or decrease in infiltration with an increase in evaporative depth.

Summarizing the effects of evaporative depth, an increase in evaporative depth produces an increase in evapotranspiration and, therefore, generally a decrease in lateral drainage and percolation. The effects on runoff are mixed but typically very small. The size of the changes are difficult to predict because the effects of evaporative depth changes are indirect. Changing the evaporative depth changes the potential storage in the evaporative zone that may not significantly change the net evapotranspiration. As evidence of this, the change in evapotranspiration is very small when the evaporative depth is increased beyond 46 cm (18 in.). In addition, the topsoil characteristics, climate, and design affect the response to a change in evaporative depth.

### Effects of Drainable Porosity

Drainable porosity is defined as the difference between porosity and field capacity; that is, the amount of water that could be vertically drained from a saturated soil by gravity forces alone. Values ranged from 0.254 to 0.686 cm/cm (0.100 to 0.270 in./in.) in this study. These values represent the volume of moisture storage capacity in excess of field capacity, divided by the bulk volume of soil including voids. Values for field capacity and wilting point remained constant at 0.668 and 0.338 cm/cm (0.263 and 0.133 in./in.), respectively. Only sandy loam soil was considered. The evaporative depth was 25 cm (10 in.), and the SCS curve number was 75. Both two- and three-layer cover designs were simulated. The results are presented in Table 9-7.

An increase in drainable porosity increases the moisture storage volume above field capacity and decreases unsaturated hydraulic conductivity for a given moisture content given a constant saturated hydraulic conductivity. Therefore, more water can infiltrate and be made available for evapotranspiration during vertical drainage. This increases the volume of evapotranspiration and decreases the volume of lateral drainage and percolation as shown in Table 9-7. However, the effect of increased drainable porosity on runoff is varied. For the three-layer cover, runoff decreased slightly at Santa Maria and increased slightly at Shreveport. For the two-layer cover,

**Table 9-6. Effects of Evaporative Depth and Runoff Curve Number**

Description <sup>1</sup>			Average Annual Volume (Percent Precipitation) <sup>2</sup>							
			Three-Layer Cover Design				Two-Layer Cover Design			
Site	Soil Type	Evap. Depth (in.)	SCS Curve Number	Runoff	ET <sup>3</sup>	Lat. <sup>4</sup> Drng.	Liner <sup>5</sup> Perc.	Runoff	ET <sup>3</sup>	Liner <sup>6</sup> Perc.
CA	SL	10	65	0.1	52.7	43.6	4.2	7.1	53.8	39.9
CA	SL	10	80	2.6	51.9	41.9	4.2	8.7	53.0	39.1
CA	SL	10	90	11.3	49.5	35.9	4.1	14.4	50.4	36.0
CA	SICL	10	75	5.5	70.8	22.1	2.2			
CA	SICL	10	85	12.7	67.6	18.0	2.2			
CA	SICL	10	95	34.4	57.3	6.4	1.6			
CA	SL	4	75	1.1	41.3	53.3	4.5	8.9	42.9	48.5
CA	SL	10	75	1.1	52.4	42.9	4.2	7.8	53.4	39.6
CA	SL	18	75	1.3	61.9	34.1	3.9	6.9	63.8	30.6
CA	SICL	4	85	12.6	53.3	30.5	3.7			
CA	SICL	10	85	12.7	67.6	18.0	2.2			
CA	SICL	18	85	12.0	77.0	11.2	1.2			
LA	SL	10	65	0.5	52.1	44.1	3.1	2.0	57.9	39.4
LA	SL	10	80	4.2	50.9	41.6	3.1	5.1	55.9	38.3
LA	SL	10	90	15.3	47.1	34.5	3.0	15.6	49.1	34.8
LA	SICL	10	75	5.8	71.2	20.3	2.3			
LA	SICL	10	85	13.5	69.6	14.5	2.2			
LA	SICL	10	95	36.5	59.0	3.0	1.4			
LA	SL	4	75	2.0	38.8	55.7	3.2	8.2	45.1	45.2
LA	SL	10	75	2.1	51.6	43.0	3.1	3.3	57.0	39.0
LA	SL	18	75	2.3	62.4	32.0	3.0	3.0	66.5	30.2
LA	SICL	4	85	12.4	55.6	28.8	2.0			
LA	SICL	10	85	13.5	68.1	14.4	2.1			
LA	SICL	18	85	14.3	75.8	8.1	1.2			

<sup>1</sup>CA = Santa Maria, CA; LA = Shreveport, LA; SL = sandy loam (HELP model default texture 6); SICL = silty, clayey loam (HELP model default texture 12). Fair grass and 46-cm (18-in.) topsoil layer was used for all cases.

<sup>2</sup>Change in storage is not included in this table; therefore, the water balance components shown do not always add up to 100.0 percent.

<sup>3</sup>ET = evapotranspiration.

<sup>4</sup>Lateral drainage from a 31-cm (12-in.) layer having a slope of 3 percent, a drainage length of 61 m (200 ft), and a hydraulic conductivity of  $3 \times 10^{-2}$  cm/sec.

<sup>5</sup>Percolation through 61-cm (24-in.) liner having a hydraulic conductivity of  $10^{-7}$  cm/sec.

<sup>6</sup>Percolation through 61-cm (24-in.) liner having a hydraulic conductivity of  $10^{-8}$  cm/sec.

runoff decreased significantly at both locations since the relative soil moisture is lower and the available storage is greater. An increase in drainable porosity reduces the head or depth of saturation resulting from a fixed quantity of infiltration. This decreases the lateral drainage while having only small effects on percolation. The design and climate affects the magnitudes of the changes in the water budget components.

**Effects of Plant Available Water Capacity**

Plant available water capacity is defined as the difference between field capacity and wilting point, or the amount of water available for plant uptake after vertical drainage by gravity has ceased. Values ranged from 0.178 to 0.508 cm/cm (0.070 to 0.200 in./in.) in this analysis. These values represent the volume of potential moisture storage between wilting point and field capacity, divided by the

**Table 9-7. Effects of Drainable Porosity and Plant Available Water Capacity**

Description <sup>1</sup>	Average Annual Volume (Percent Precipitation) <sup>2</sup>								
	Three-Layer Cover Design						Two-Layer Cover Design		
	Site	DP	PAWC	Runoff	ET <sup>3</sup>	Lat. <sup>4</sup> Drng.	Liner <sup>5</sup> Perc.	Runoff	ET <sup>3</sup>
CA	0.18	0.07	1.07	48.51	46.45	4.31	8.57	49.78	42.16
CA	0.18	0.13	1.14	52.54	42.83	4.22	7.87	53.55	39.41
CA	0.18	0.20	1.30	56.43	39.43	4.12	7.06	57.18	37.02
CA	0.10	0.13	1.17	48.87	47.38	4.33	10.48	50.40	40.02
CA	0.18	0.13	1.14	52.53	42.81	4.22	7.87	53.55	39.41
CA	0.27	0.13	1.1	55.8	39.6	4.1	5.22	57.34	38.20
LA	0.18	0.07	2.08	47.38	47.12	3.12	4.36	54.57	40.08
LA	0.18	0.13	2.15	51.74	42.86	3.08	3.45	57.05	38.84
LA	0.18	0.20	2.26	55.68	38.92	3.04	2.98	59.99	36.69
LA	0.10	0.13	2.10	46.93	47.66	3.12	6.63	55.24	37.65
LA	0.18	0.13	2.15	51.74	42.86	3.08	3.45	57.05	38.84
LA	0.27	0.13	2.2	55.7	38.8	3.0	2.32	59.60	37.49

<sup>1</sup>CA = Santa Maria, CA; LA = Shreveport, LA; DP = drainable porosity (vol/vol); PAWC = plant available water capacity (vol/vol). All cases are for 46 cm (18 in.) of sandy loam topsoil (HELP model default texture 6); fair grass; evaporative depth = 25 cm (10 in.); and curve number = 75.

<sup>2</sup>Change in storage is not included in this table; therefore, the water balance components shown do not always add up to 100.0 percent.

<sup>3</sup>ET = evapotranspiration.

<sup>4</sup>Lateral drainage from a 31-cm (12-in.) layer having a slope of 3 percent, a drainage length of 61 m (200 ft), and a hydraulic conductivity of  $3 \times 10^{-2}$  cm/sec.

<sup>5</sup>Percolation through 61-cm (24-in.) liner having a hydraulic conductivity of  $10^{-7}$  cm/sec.

<sup>6</sup>Percolation through 61-cm (24-in.) liner having a hydraulic conductivity of  $10^{-6}$  cm/sec.

bulk volume of soil including voids. The values for wilting point and drainable porosity remained constant at 0.338 and 0.457 cm/cm (0.133 and 0.180 in./in.), respectively. Only sandy loam soil was considered. The evaporative depth was 25 cm (10 in.), and the SCS runoff curve number was 75. Both two- and three-layer cover designs were simulated. The results are presented in Table 9-7.

Increasing the plant available water capacity provides a greater volume of water available for evapotranspiration after vertical drainage has nearly ceased. This results in larger volumes of evapotranspiration as shown in Table 9-7. Consequently, the lateral drainage and percolation decreases. The change in the volume of runoff was design dependent. Since increasing the plant available water capacity results in an increased moisture content at field capacity, there is a greater potential for higher antecedent moisture conditions or relative moisture content, resulting in a higher curve number. As such, the runoff for the three-layer cover systems increased with increasing plant available water capacity. Runoff decreased for the two-layer cover systems because infiltration is limited by the storage volume above the liner. As such, increas-

ing the plant available water capacity increases the storage volume, reducing the limits on infiltration and the runoff. As shown in Table 9-7, the runoff from the two-layer cover approaches the runoff from the three-layer cover as the storage potential in the two-layer cover becomes large, that is for large values of drainable porosity and plant available water capacity. In all cases the increases in evapotranspiration were great enough to offset any decrease in runoff; therefore, leachate drainage and percolation always decreased. The size of the changes in the water budget components were dependent on the climate and design. The results would also be dependent on the type of topsoil.

#### Liner/Drain Systems

This section examines the effects of liner/drain system design on the performance of the drain system under conditions typical of cover systems, and leachate collection systems in open and closed landfills. Performance was determined by the apportionment of the drainage into the drain layer between lateral drainage and percolation through the liner. In addition, the effect of design on the resulting depth of saturation also was examined. For

**Table 9-8. Sensitivity of Lateral Drainage and Liner Percolation to Lateral Drainage Slope and Length**

Annual <sup>1</sup> Infilt. (in.)	Slope S (ft/ft)	Length L (ft)	S*L (ft)	L/S (ft)	Avg. Annual Vol. (% Inflow)		Max. Head In Lat. Drng. Layer (in.)
					Lat. <sup>2</sup> Drng.	Liner <sup>3</sup> Perc.	
50	0.01	25	0.25	2,500	96.71	3.29	13.8
50	0.01	75	0.75	7,500	95.89	4.11	29.7
50	0.01	225	2.25	22,500	93.43	6.57	58.2
50	0.03	25	0.75	830	96.85	3.15	12.3
50	0.03	75	2.25	2,500	96.36	3.64	24.8
50	0.03	225	6.75	7,500	95.10	4.90	42.3
50	0.09	25	2.25	280	97.37	2.63	8.5
50	0.09	75	6.75	830	96.87	3.13	16.2
8	0.01	25	0.25	2,500	83.73	16.27	1.2
8	0.01	75	0.75	7,500	82.29	17.71	3.4
8	0.01	225	2.25	22,500	78.51	21.49	9.4
8	0.03	25	0.75	830	84.16	15.84	0.5
8	0.03	75	2.25	2,500	83.59	16.41	1.1
8	0.03	225	6.75	7,500	82.28	17.72	3.5
8	0.09	25	2.25	280	84.35	15.65	0.2
8	0.09	75	6.75	830	84.23	15.77	0.4

<sup>1</sup>Value of 50 in./yr represents inflow through an open landfill; the temporal distribution is based on rainfall records for Shreveport, LA. Value of 8 in./yr represents inflow through landfill cover; the temporal distribution is uniform throughout the year.

<sup>2</sup>Lateral drainage from a layer having a slope of 3 percent, drainage length of 75 ft, porosity of 0.351 vol/vol, field capacity of 0.174 vol/vol, and a saturated hydraulic conductivity of  $10^{-2}$  cm/sec

<sup>3</sup>Percolation through a 24-in.-thick soil liner having a saturated hydraulic conductivity of  $10^{-7}$  cm/sec.

the cover system or open landfill the drainage into the drain layer was 127 cm/yr (50 in./yr), distributed temporally in accordance with the precipitation at Shreveport. For the closed landfill the drainage into the drain layer was distributed uniformly through time at a rate of 20 cm/yr (8 in./yr).

Four types of liner/drain systems are examined in the various parts of this study to determine their performance: a sand drainage layer underlain by a clay liner, a sand drainage layer underlain by a geomembrane, a sand drainage layer underlain by a composite liner, and double liner systems. For the clay liner system this sensitivity analysis determines the effects of the saturated hydraulic conductivity of the liner and drain layer, slope of the liner, and drain spacing. For the geomembrane and composite liner systems, the effects of synthetic liner leakage fraction and saturated hydraulic conductivity of the geomembrane's subsoil are examined. The sensitivity of the parameters affecting the synthetic liner leakage fraction are presented graphically. For the double liner systems, the effectiveness of several different systems in preventing and detecting leakage from the primary liner prior to leaking through the secondary liner was compared. In all systems the thickness of the drain layer was greater than the peak depth of saturation

in the drain layer, and the thickness of the clay liner or subsoil below a geomembrane was 61 cm (24 in.).

**Clay Liner/Drain Systems**

*Saturated Hydraulic Conductivities.* The liner/drain system used in this analysis is shown as Design A in Figure 9-10. The value of KD (the saturated hydraulic conductivity of the drain layer) ranged from 0.001 to 1 cm/sec while the value of KP (the saturated hydraulic conductivity of the clay liner) ranged from  $10^{-8}$  to  $10^{-5}$  cm/sec. The slope of the liner surface toward the drainage collector was 3 percent, and the maximum drainage length to the collector was 23 m (75 ft). The results of the drainage efficiency determinations for the various combinations of KD and KP are shown in Figure 9-4, where the average annual volumes of lateral drainage and percolation expressed as a percentage of annual inflow are plotted.

For the large unsteady inflows totaling 127 cm/yr (50 in./yr), only designs where the saturated hydraulic conductivity of the liner was equal to or less than  $10^{-7}$  cm/sec limited the percolation through the liner to volumes less than 5 percent of the annual inflow (6.4 cm [2.5 in.]). The effect of KD on the drainage efficiency for these low permeability liners is fairly small. Changing KD from 0.001 cm/sec to 1 cm/sec reduced the percolation from 7 per-

cent to 1 percent of the inflow for a KP of  $10^{-7}$  cm/sec and from 0.7 percent to 0.1 percent for a KP of  $10^{-8}$  cm/sec. For a KP value of  $10^{-6}$  cm/sec, only a KD value of 1 cm/sec or greater can reduce the percolation to less than 10 percent of the annual inflow. Liners having a KP of  $10^{-5}$  cm/sec are largely ineffective no matter how large the value of KD is.

For smaller steady inflows of 20 cm/yr (8 in./yr) typical of the infiltration through some cover systems, only liners having a value of KP equal to or less than  $10^{-7}$  cm/sec limited leakage except for designs having a KP of  $10^{-6}$  cm/sec and a very large KD value, 1 cm/sec or greater. As above, the effect of KD on the drainage efficiency is small. Changing KD from 0.001 cm/sec to 1 cm/sec reduced the percolation from 22 percent to 15 percent of the inflow for a KP of  $10^{-7}$  cm/sec and from 2.3 percent to 1.5 percent for a KP of  $10^{-8}$  cm/sec. Liners having a KP of  $10^{-7}$  cm/sec leaked between 2.5 and 5.1 cm/yr (1 and 2 in./yr) while liners having a KP of  $10^{-8}$  cm/sec leaked between 0.25 and 0.51 cm/yr (0.1 to 0.2 in./yr).

Summarizing the results shown in Figure 9-4, the saturated hydraulic conductivity of the liner is the primary control of leakage through a clay liner. At hydraulic conductivities below about  $10^{-6}$  cm/sec the leakage is nearly proportional to the value of KP; that is, an order of magnitude decrease in the value of KP yields nearly an order of magnitude decrease in percolation. The value of KD has only a small effect on the leakage through liners having a KP of  $10^{-7}$  cm/sec or less. Changing the value of KD by three orders of magnitude when using these low permeability liners yields much less than an order of magnitude change in percolation.

Similar effects are also seen in Figures 9-5 and 9-6 which relate the KD/KP design ratio to the resulting ratio of lateral drainage to percolation. The curves in Figure 9-5 are log-least-squares regressions for several ranges of steady-state heads resulting from a steady-state inflow of 20 cm/yr (8 in./yr). The curves in Figure 9-6 are log-least-squares regressions for several ranges of peak  $\bar{y}$  resulting from a unsteady inflow of 127 cm/yr (50 in./yr). The plotted points are QD/QP ratios for the given KD/KP ratio; their symbols indicate the value of KD used in obtaining the result. The actual steady-state  $\bar{y}$  and peak  $\bar{y}$  values were both grouped into four ranges of heads. In Figure 9-5 steady-state heads ranging from 26 to 30.7 cm (10.2 to 12.1 in.) were grouped together as were heads ranging from 3.56 to 4.06 cm (1.4 to 1.6 in.), equaling 0.508 cm (0.2 in.), and less than 0.127 cm (0.05 in.). In Figure 9-6 peak heads ranging from 6.1 to 6.4 cm (2.4 to 2.5 in.) were grouped together as were heads ranging from 19.3 to 23.6 cm (7.6 to 9.3 in.), from 41.15 to 69.6 cm (16.2 to 27.4 in.), and from 116.1 to 153.2 cm (45.7 to 60.3 in.).

Figures 9-5 and 9-6 show that percolation tends to dominate at ratios of KD/KP below  $10^7$ . This is particularly true as the depth of saturation or inflow decreases. When heads remain constant, the ratio of lateral drainage to percolation is a linear function of KD/KP. Using the maximum head allowed by RCRA of 31 cm (12 in.) and the current minimum KD/KP ratio implied by RCRA of  $10^5$ , a percolation of 2.3 percent of inflow results; however, an unusually large steady-state inflow of 203 cm/yr (80 in./yr) or 0.559 cm/day (0.22 in./day) is required to achieve this condition. When using the RCRA guidance design, therefore, the peak and steady-state average heads will be considerably smaller than 31 cm (12 in.) at virtually all locations.

*Slope and Drainage Length.* The combinations of slope and drainage length used in this analysis are listed in Table 9-8 along with resulting average annual volumes of lateral drainage and percolation expressed as a percentage of annual inflow. The table also contains the resulting maximum heads above the soil liner. The slope ranged from 0.003 to 0.028 cm/cm (0.01 to 0.09 ft/ft) (1 to 9 percent) while the drainage length (L) ranged from 8 to 69 m (25 to 225 ft). The saturated hydraulic conductivities of the lateral drainage and soil liners were  $10^{-2}$  and  $10^{-7}$  cm/sec, respectively. The product S\*L and the ratio L/S ranged from 0.76 to 2 m (0.25 to 6 ft) and 85 to 6,858 m (280 to 22,500 ft), respectively. S\*L is the head contributed by the liner at the crest of the drainage layer.

The results indicate that the volumes of lateral drainage and percolation vary little with changes in slope and drainage length under both steady and unsteady inflows. A ninefold increase in slope reduced the percolation by a maximum of 25 percent for the unsteady inflow and 13 percent for the steady inflow. As the drainage length is reduced and the slope increased, the lateral drainage rate increases. As a result, the head decreases and is maintained at smaller depths for shorter durations. Consequently, the percolation decreases since it is a function of the head on the liner. A ninefold decrease in drainage length reduced the percolation by a maximum of 50 percent for the unsteady inflow and 25 percent for the steady inflow. A ninefold increase in slope and decrease in length decreased the percolation by about 60 percent for the unsteady inflow and about 30 percent for the steady inflow.

The head in the drain layer varies greatly with changes in slope and drainage length. For a steady inflow the average head increases linearly with an increase in drainage length and an increase in the inverse of the slope, as shown in Figure 9-7. A similar relationship exists between the peak average head during the simulation and L/S for unsteady inflow. The average head is slightly influenced by the product of the slope and drainage length when the head is similar to this product.

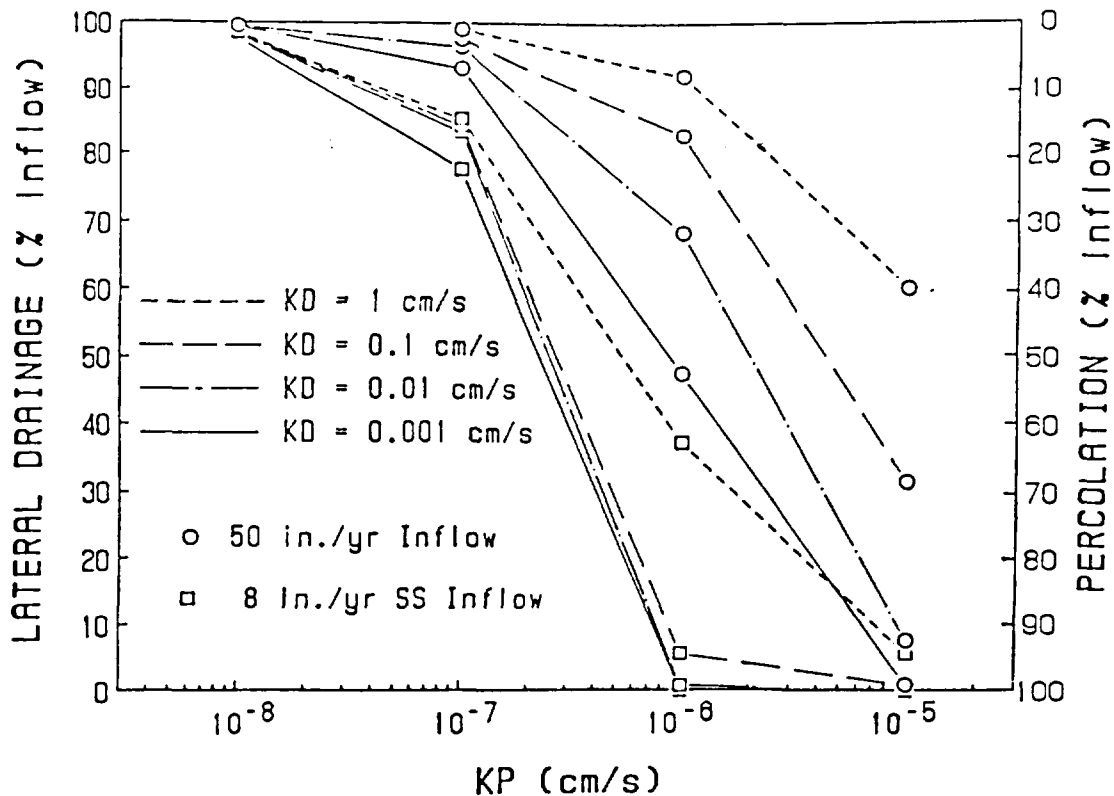

Figure 9-4. Effect of saturated hydraulic conductivity on lateral drainage and percolation.

### Geomembrane/Drain Systems

A single synthetic liner under a drain layer as shown in Design B in Figure 9-10 is examined in this section. It is assumed that the synthetic liner was laid directly on a 3-m (10-ft) thick layer of native subsoil. The drainage layer had a saturated hydraulic conductivity of  $10^{-2}$  cm/sec, a slope of 3 percent, and a drainage length of 23 m (75 ft). This case will be used to demonstrate the influence of the synthetic liner leakage fraction and the saturated hydraulic conductivity of the native subsoil on the liner system performance. The properties of the subsoil ranged from sand to clay in the analysis.

*Liner Leakage Fraction.* Brown et al. (4) conducted laboratory experiments and developed predictive equations to quantify leakage rates through various size holes in synthetic liners over soil. They assumed that the measured leakage rates corresponded to a uniform vertical percolation rate equal to the saturated hydraulic conductivity through a circular cross-sectional area of the soil liner directly beneath the hole. Using the data relating leakage and cross-sectional area of flow, Brown et al. (4) developed predictive equations for the radius or area of this flow cross section as a function of hole size, depth of leachate ponding, and saturated hydraulic conductivity of the soil. Figure 9-8 presents their results. The radius of saturated flow through the subsoil was significantly greater than the radius of the hole in the synthetic liner. In this paper, the cross-sectional area of saturated flow

was multiplied by the number of holes per unit area of synthetic liner to compute the synthetic liner leakage fraction. Liner leakage fraction is simply defined as the total horizontal area of saturated flow through the subsoil beneath all of the liner holes divided by the horizontal area of the liner.

Liner leakage fraction is a function of many parameters, some quantitatively defined and others qualitatively defined. Liner leakage fraction increases linearly with increases in the number of holes of the same size and shape. Shape also has a strong effect on the leakage; tears have larger leakage than punctures. Increasing the size of circular holes yields only a slight increase in the leakage, while increasing the length of a tear or bad seam increases the leakage nearly linearly. Leakage also increases nearly linearly with increases in head or depth of saturation above the liner. The leakage fraction also is affected by the gap width between the liner and the subsoil. Gap width is a measure of the seal between the liner and the subsoil. The smaller the gap the better the seal. The seal is a function of the subsoil, installation, liner placement, and subsoil preparation. Installation of the liner on coarse-grained subsoil, clods, debris, or filter fabric provides a poor seal as will wrinkles in the liner. Coarse-grained subsoils decrease the leakage fraction while greatly increasing the leakage. The greater permeability of coarse materials allows greater flow through a smaller area of saturated flow, reducing the

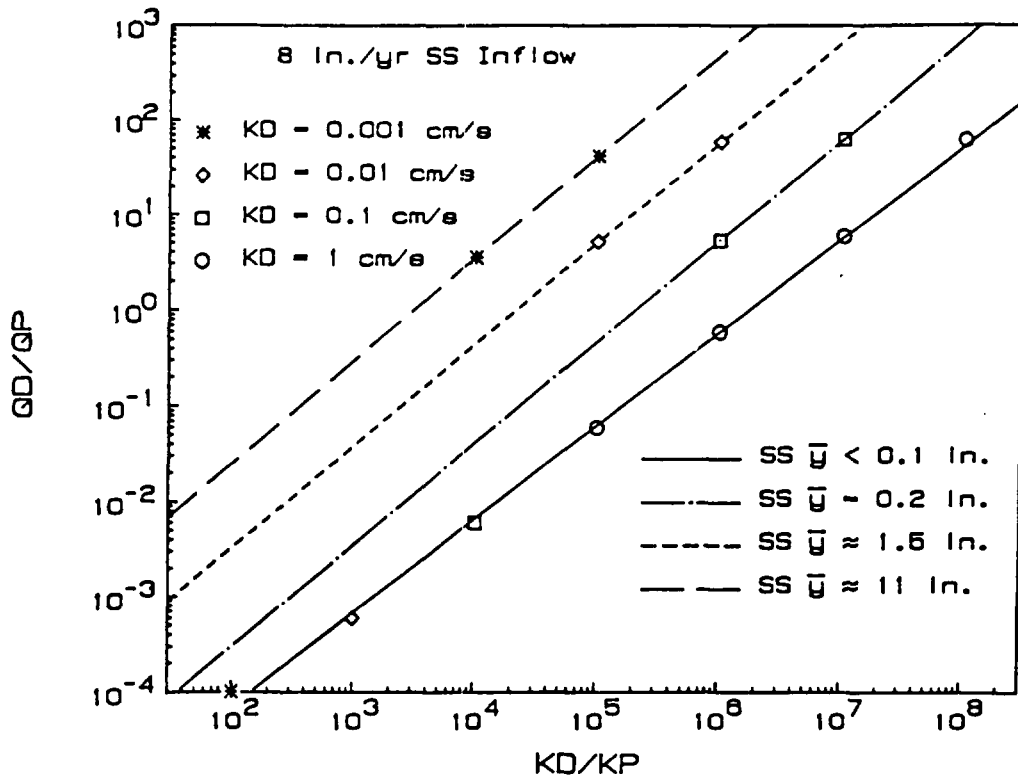

Figure 9-5. Effect of ratio of drainage-layer saturated hydraulic conductivity to soil-liner saturated hydraulic conductivity on ratio of lateral drainage to percolation for steady-state (SS) inflow of 20 cm/yr (8 in./yr).

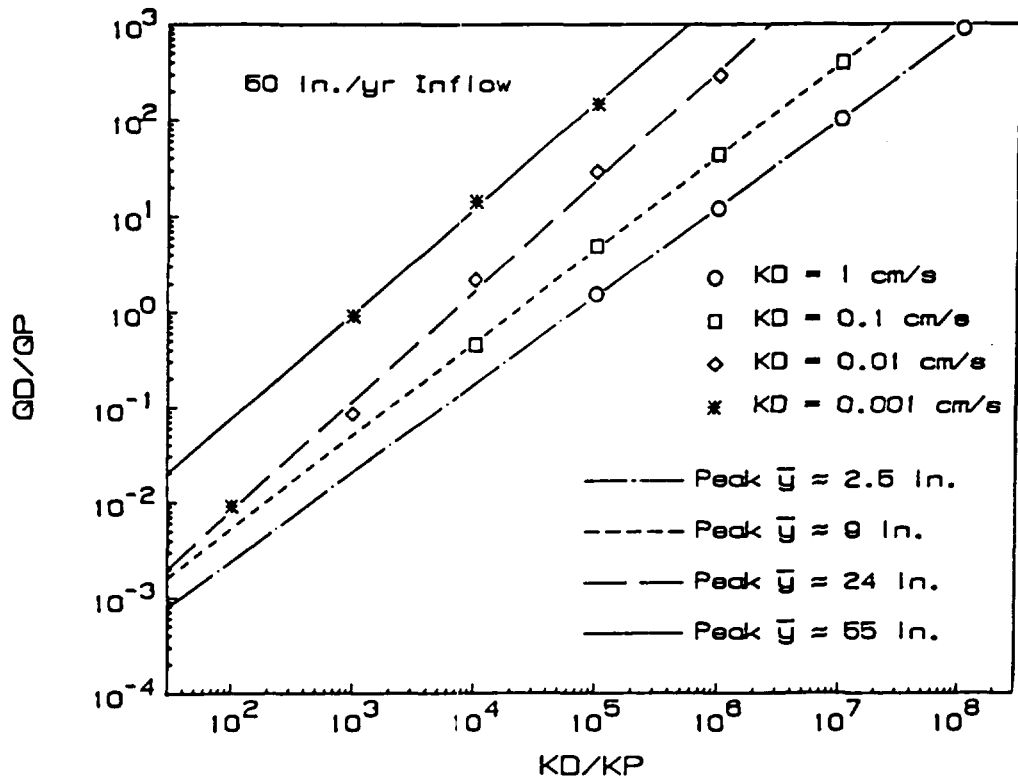

Figure 9-6. Effect of ratio of drainage-layer saturated hydraulic conductivity to soil-liner saturated hydraulic conductivity on ratio of lateral drainage to percolation for unsteady inflow of 127 cm/yr (50 in./yr).

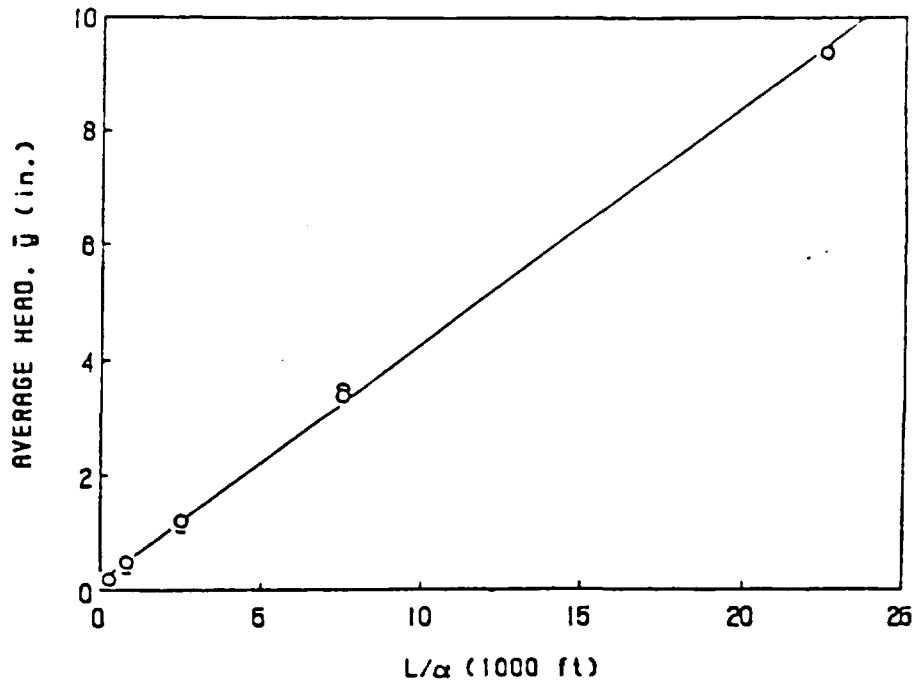

Figure 9-7. Effect of ratio of drainage length to drainage layer slope on the average saturated depth in drainage layer ( $KD=10^{-2}$  cm.s) above a soil liner ( $KP=10^{-7}$  cm/s) under a steady-state inflow rate of 20 cm/yr (8 in./yr).

spreading required to accommodate the leakage through the liner.

**System Performance.** The percolation rate through a leaking synthetic liner is a linear function of the leakage fraction for a given subsoil when the average head on the liner is constant. The percolation rate expressed as a percentage of inflow rate is shown graphically in Figure 9-9 as a function of the leakage fraction. This relationship is shown for a range of values of the average head and for a steady inflow rate of 20 cm/yr (8 in./yr). Figure 9-9 emphasizes the significant influence of average head or inflow on controlling the distribution of the inflow between vertical percolation and lateral drainage. This figure shows that to maintain the vertical percolation rate at less than 1 percent of the inflow rate for heads greater than 0.25 cm (0.1 in.), the leakage fraction for a clay subsoil ( $KP = 10^{-6}$  cm/sec) must be less than  $5 \times 10^{-4}$  and for a sandy subsoil ( $KP = 10^{-3}$  cm/sec) must be less than  $5 \times 10^{-7}$ . The overall effectiveness of a geomembrane is equivalent to a soil liner having a saturated hydraulic conductivity equal to the product of the leakage fraction and the saturated hydraulic conductivity of the subsoil when the permeability of the subsoil is equal to greater than the conductivity of the material above the liner.

#### Double Liner Systems

Four double liner systems shown as Designs C through F in Figure 9-10 are examined in this section. These designs are presented here to illustrate the strengths and

weaknesses of various double liner configurations and to show why certain designs would be expected to yield poor performance. The designs are evaluated for effectiveness in early leak detection and for minimization of vertical percolation out of the landfill (5).

For this discussion it is assumed that the slope of the drainage layer is 3 percent, the drainage length is 23 m (75 ft), the saturated hydraulic conductivity of the drainage layer is  $10^{-2}$  cm/sec, and the saturated hydraulic conductivity of the soil liner is  $10^{-7}$  cm/sec. In evaluating designs with double synthetic liners, it was assumed that the degree of degradation of each synthetic liner was identical. However, identical degradation would not yield identical leakage fractions for both liners since they have different heads on the liners and different subsoils. For Design E the leakage fraction of the lower liner was increased by a factor of 8 to account for different subsoils, but this corrected leakage fraction was then reduced by a factor ranging from 1 to 24 to account for different heads. For Design F the leakage fraction of the lower liner was reduced by a factor between 8 and 24, varying as a function of the differences between the heads on the two liners. Larger reduction factors were used for smaller leakage fractions in both designs. The leakage fraction used for the top synthetic liner is used for reporting the results.

Designs C through F were evaluated using the HELP model, which predicted lateral drainage in each drainage

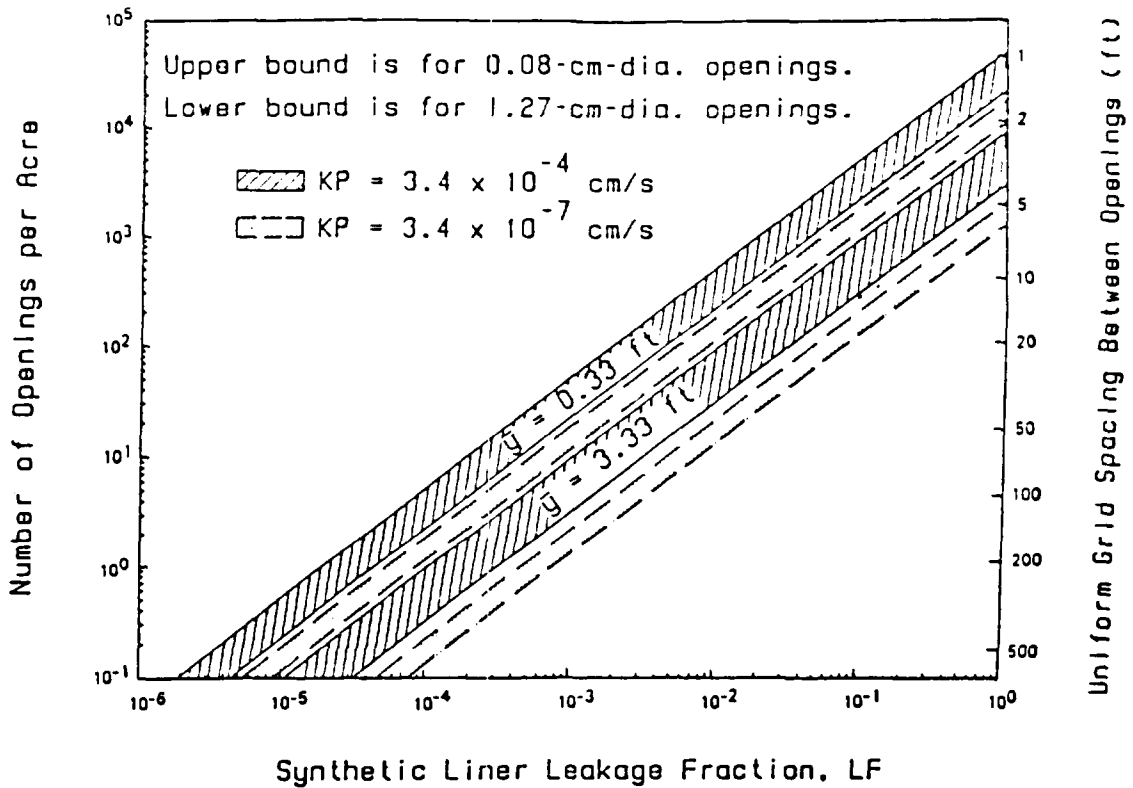

Figure 9-8. Synthetic liner leakage fraction as a function of density of holes, size of holes, head on the liner, and saturated hydraulic conductivity of the liner.

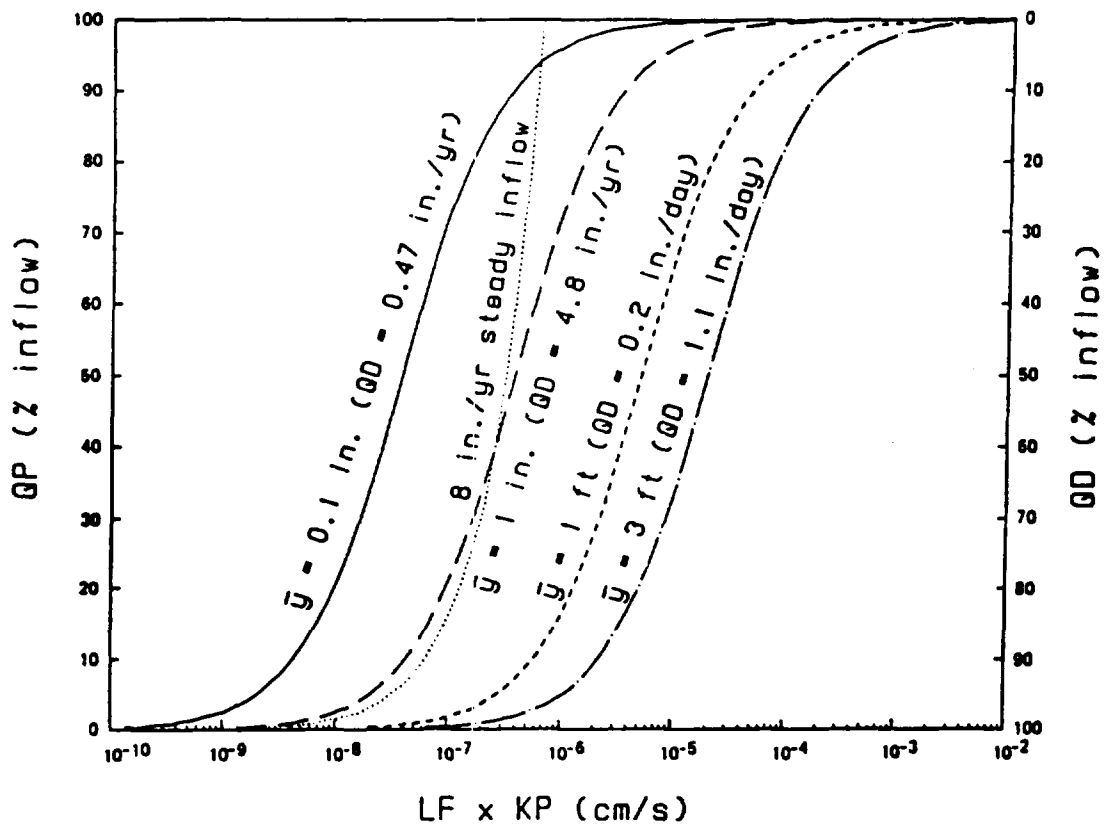

Figure 9-9. Effect of leakage fraction on system performance.

layer and vertical percolation through each synthetic liner and each soil liner. These predictions were based on 20 cm/yr (8 in./yr) of infiltration passing through the waste layer and reaching the primary leachate collection system. This inflow was distributed uniformly in time. Figures 9-11 and 9-12 show the results in terms of lateral drainage from the secondary drainage layer and vertical percolation through the bottom soil liner as functions of synthetic liner leakage fraction of the top membrane.

Design C consists of a primary leachate drainage layer underlain by a synthetic liner, a secondary drainage layer, and a soil liner. As shown in Figure 11, this design is not very effective. Large quantities of leakage occurred at fairly low leakage fractions and no leakage (lateral drainage) was detected from the secondary drainage layer until the synthetic liner leakage fraction exceeded about  $10^{-5}$ . At smaller synthetic liner leakage fractions, the leachate percolated vertically through the soil liner as fast as the leakage through the synthetic liner occurred. The product of the saturated hydraulic conductivity of the secondary drainage layer times the synthetic liner leakage fraction must be greater than or approximately equal to the saturated hydraulic conductivity of the soil liner before leakage will be detected using this design. At the time leakage is detected, the vertical percolation rate through the soil liner could be about 16 percent of total inflow.

Design D consists of a primary drainage layer underlain by a synthetic liner, a soil liner, a secondary drainage layer, and a second soil liner. The soil liner immediately below the synthetic liner is very effective in minimizing vertical percolation (leakage through the primary liner); however, a synthetic liner leakage fraction greater than  $10^{-2}$  to  $10^{-1}$  would be required before leachate would be collected from the secondary drainage layer. Because the vertical percolation through the first liner is so small, practically all of the leakage is removed by vertical percolation through the bottom soil liner as shown in Figure 9-12. This design is ineffective since the leakage detection system would not function.

Design E consists of a primary drainage layer underlain by a synthetic liner, a secondary drainage layer, a second synthetic liner, and a soil liner. In this case, any leakage through the upper synthetic liner will readily pass through the underlying drainage medium to the lower synthetic liner. Since the lower synthetic liner is underlain by a soil liner, most leakage will be collected by lateral drainage. Figure 9-11 shows that leakage will be detected far in advance of significant vertical percolation from the landfill. That is, the leakage fraction of the synthetic liners at which leakage detection will occur is several orders of magnitude smaller than the leakage fraction at which significant vertical percolation from the landfill will occur. The leakage lost by percolation is vir-

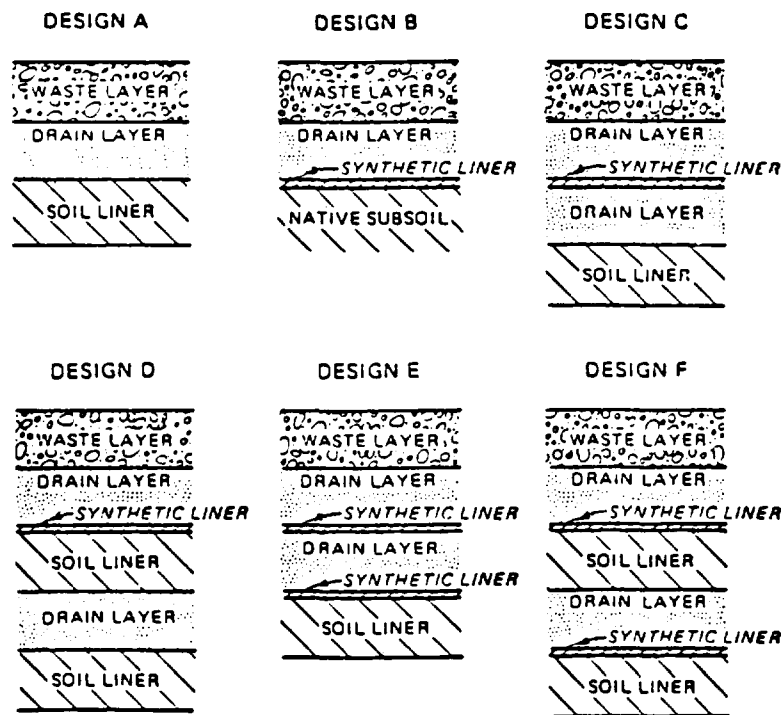

Figure 9-10. Liner designs.

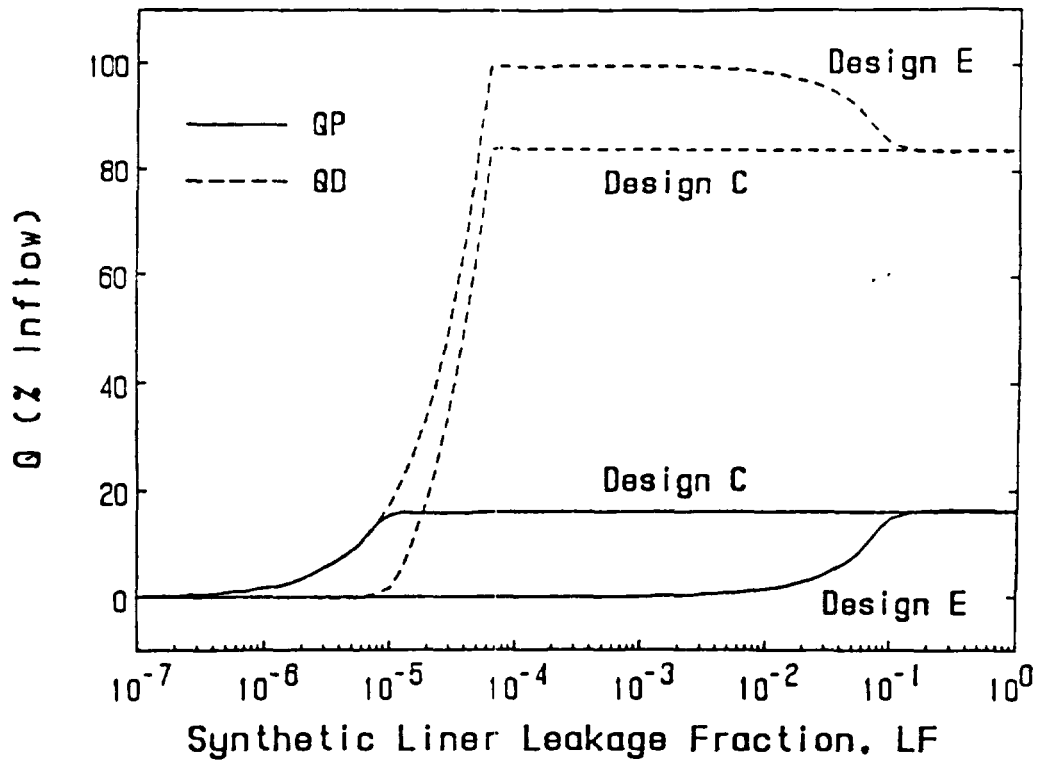

Figure 9-11. Percent of inflow to primary leachate collection layer discharging from leakage detection layer and bottom liner double-liner systems C and E.

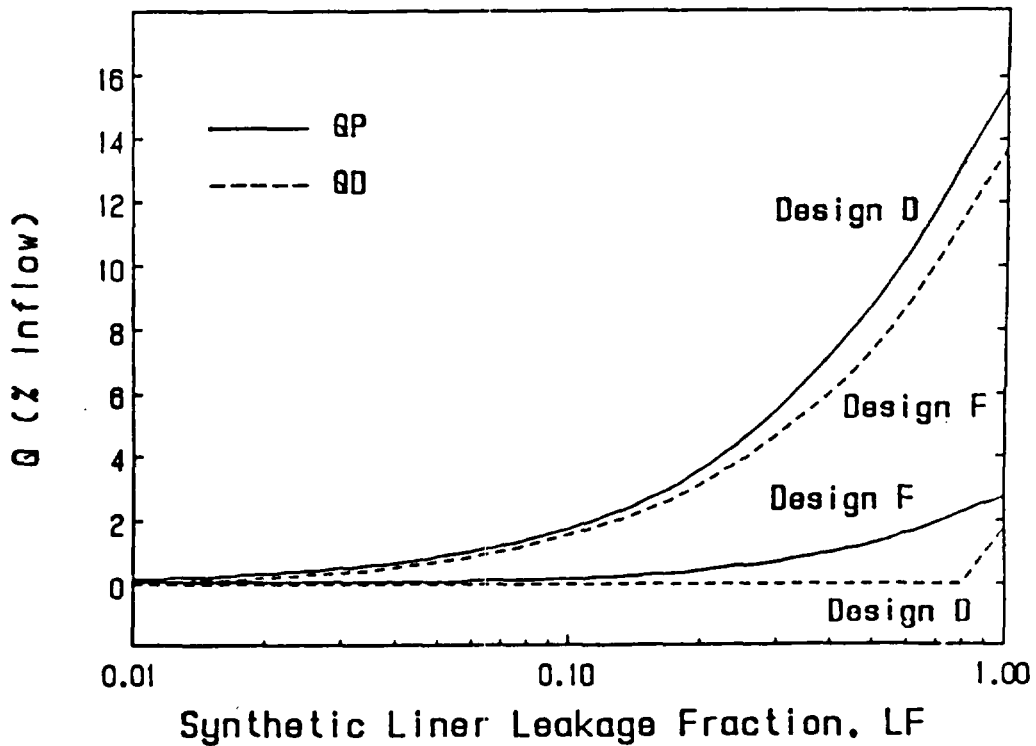

Figure 9-12. Percent of inflow to primary leachate collection layer discharging from leakage detection layer and bottom liner for double-liner systems D and F.

tually the same as for Design D but detection is much better. This design is effective at minimizing leakage from the landfill and at detecting leakage through the primary liner, but significant leakage through the primary liner may occur at fairly low liner leakage fractions.

Design F consists of a primary drainage layer underlain by a synthetic liner, a soil liner, a secondary drainage layer, a second synthetic liner, and a second soil liner. Figure 9-12 shows that the addition of the lower synthetic liner improves the system performance in comparison to the performance of Design D. Leakage is detected whenever leakage occurs. Even at leakage fractions of  $10^{-3}$  when only 0.02 percent of the inflow leaks through the primary liner, half of the leakage is collected in the secondary drainage layer. The depth of saturation in the secondary drainage layer is lower than in the primary layer. This sufficiently reduces the leakage through the second synthetic liner to permit detection whenever the primary liner leaks. Design F is a very effective double-liner design because it minimizes the leakage through the primary liner and from the landfill and collects leakage at all leakage fractions.

A comparison of the four designs shows that Design F is the most effective in detecting the earliest leaks with the least amount of vertical leakage through the primary liner and also through the bottom soil liner. Design D yields the same quantity of leakage through the primary liner; however, leakage in Design D would probably never be detected or collected. Therefore, the bottom liner in Design D is not functional. Designs D and E yield the same leakage through the bottom liner but Design E detects leakage through the primary liner at the lowest leakage fraction. Design C also detects leaks at very small leakage fractions but allows significant vertical percolation through the bottom soil liner before detection. The leakage through the primary liner in Designs C and E is large even at low leakage fractions. Therefore, synthetic membranes placed on highly permeable subsoils are ineffective except for very low inflows and for very low leakage fractions. Synthetic membranes are best used in conjunction with a low-permeability soil as a composite liner. Comparison of the results for Designs B and C demonstrates this point. Both designs are composed of one synthetic membrane and one soil liner, but the leakage from the composite liner (Design B) shown in Figure 9-9 as the curve for 20 cm/yr (8 in./yr) steady inflow is much lower than the leakage from the double liner system (Design C) as shown in Figure 9-11.

It is interesting to compare the single-liner performance of Design B to the double-liner performance of Design D, assuming the soil-liner-saturated hydraulic conductivity in Design B is the same as Design D. The vertical percolation leaving the system in Design B is essentially the same as that leaving the secondary liner in Design D as seen by comparing Figure 9-12 to the curve in Figure 9-9 for 20 cm/yr (8 in./yr) steady inflow. The secondary liner

in Design D is nonfunctional since the percolation rate of the second soil liner is generally equal to or greater than the leakage rate.

## SUMMARY OF SENSITIVITY ANALYSIS

The interrelationship between variables influencing the hydrologic performance of a landfill cover is complex. It is difficult to isolate one parameter and exactly predict its effect on the water balance without first placing restrictions (sometimes severe restrictions) on the values of the remaining parameters. With this qualification in mind, the following general summary statements are made.

The primary importance of the topsoil depth is to control the extent or existence of overlap between the evaporative depth and the head in the lateral drainage layer. The greater this overlap, the greater will be evapotranspiration and runoff. Surface vegetation has a significant effect on evapotranspiration from soils with long flow-through travel times and large plant available water capacities; otherwise, the effect of vegetation on evapotranspiration is small. The general influence of surface vegetation on lateral drainage and percolation is difficult to predict outside the context of an individual cover design. Clay soils increase runoff and evapotranspiration and decrease lateral drainage and percolation. Simulations of landfills in colder climates and in areas of lower solar radiation are likely to show less evapotranspiration and greater lateral drainage and percolation. An increase in the runoff curve number will increase runoff and decrease evapotranspiration, lateral drainage, and percolation. As evaporative depth, drainable porosity, or plant available water increase, evapotranspiration tends to increase and lateral drainage and percolation tend to decrease; the effect on runoff is varied.

The sensitivity analysis shows that the ratio of lateral drainage to percolation is a positive function of the ratio of  $KD/KP$  and the average head above the liner. However, the average head is a function of  $QD/QD$  and  $L/S$ . The quantity of lateral drainage, and, therefore, also the average head, is in turn a function of the infiltration. Therefore, the ratio of lateral drainage to percolation increases with increases in infiltration and the ratio of  $KD/KP$  for a given drain and liner design. The ratio of lateral drainage to percolation for a given ratio of  $KD/DP$  increases with increases in infiltration and the term  $S/L$ . The percolation and average head above the liner is a positive function of the term  $L/S$ .

Leakage through geomembrane increases with the number and size of holes, the depth of water buildup on the liner, the permeability of the subsoil, and the gap between the liner and the subsoil. Geomembranes reduce leakage through liner systems by reducing the area of saturated flow through the subsoil. The overall effectiveness of a geomembrane system is equivalent to a soil liner having a saturated hydraulic conductivity equal to the product of the saturated hydraulic conductivity of the

subsoil and the ratio of the reduced area of flow through the subsoil to the area of the liner. Composite liners provide the best reduction in leakage. Drain systems that yield low head buildup on the geomembrane improve the performance of a geomembrane system.

## REFERENCES

1. Schroeder, P. R., and Peyton, R. L. 1987. "Verification of the Hydrologic Evaluation of Landfill Performance (HELP) Model Using Field Data." EPA 600/2-87-050. EPA Hazardous Waste Engineering Research Laboratory, Cincinnati, OH.
2. Schroeder, P. R., R. L. Peyton, and J. M. Sjostrom. 1988. Hydrologic Evaluation of Landfill Performance (HELP) Model: Vol. III User's Guide for Version 2. Internal Working Document. USAE Waterways Experiment Station, Vicksburg, MS.
3. U.S. Department of Agriculture, Soil Conservation Service. 1972. Section 4, Hydrology. In: National Engineering Handbook, U.S. Government Printing Office, Washington, DC. 631 pp.
4. Brown, K.W., J.C. Thomas, R.L. Lytton, P. Jayawikrama, and S.C. Bahrt. 1987. Quantification of Leak Rates Through Holes in Landfill Liners. EPA/600/S2-87-062. EPA Office of Research and Development, Cincinnati, OH.
5. Peyton, R. L. and Schroeder, P. R. 1990. "Evaluation of Landfill-Liner Designs." Vol. 116, No. 3, Journal of Environmental Engineering Division, American Society of Civil Engineers.

## CHAPTER 10

### GAS MANAGEMENT SYSTEMS

#### GAS GENERATION

The information in this chapter applies mainly to Subtitle D landfills. Hazardous waste landfills (Subtitle C) do not usually contain significant amounts of organic materials and, thus, normally have a minimal gas management system as a component of the final cover.

Gas generation in a landfill system poses several problems. If allowed to accumulate, gas is an explosion hazard. It also provides stress to vegetation by lowering the oxygen content available at the roots, severely affecting the ability of the cover to support vegetation. In the absence of adequate corridors for the gas to escape, gas pressures can increase sufficiently to physically disrupt the cover system as well, generating large cracks and rupturing the geomembrane. Other problems include odor, toxic vapors, and uncontrolled gas migration which can cause deterioration of nearby property values.

Gas generation is a product of anaerobic decomposition of organic materials placed in the landfill. The decomposition can be described by the reaction:

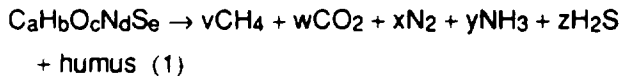

The composition of landfill gas generally is about 50 percent methane, 40 percent carbon dioxide, and 10 percent other gases including nitrogen products. This particular mix of gases generally will not occur until after the landfill becomes anaerobic. During the first year after the materials are placed in the landfill, the gas is predominantly carbon dioxide and is unsuitable for recovery and use. After the methane content rises, the gas can be mined as a fuel or energy source. However, the BTU value of landfill gas is about half that of natural gas and, therefore, is generally too low to substitute directly for natural gas. Landfill gas requires purification and is frequently used in conjunction with natural gas.

Waste decomposition rates and hence gas production rates are moisture dependent. Highest gas production rates occur at moisture contents ranging from 60 to 80 percent of saturation. In modern landfill design, infiltration of water into the waste is restricted to a practical minimum; therefore, optimum moisture contents may never be achieved. Consequently, gas production rates may be

much lower than anticipated, decreasing the attractiveness of gas recovery systems. To maximize gas production, strategies such as leachate recirculation should be employed to distribute bacteria, nutrients, and moisture more uniformly. Typical gas production rates from wet, anaerobic wastes are about 20 to 50 mL/kg/day. These high production rates will continue for decades. Production at low rates may continue for centuries because of quantity of material and resistance of some material to biodegradation.

#### GAS MIGRATION

Gas migrates from landfills through two mechanisms—convection and diffusion. Convection is transport induced by pressure gradients formed by gas production in layers surrounded by low hydraulic conductivity or saturated layers. Convection also results from buoyancy forces because methane is lighter than carbon dioxide and air.

Diffusion is the transport of materials induced by concentration gradients. Anaerobic decomposition produces a gas mixture with concentrations of methane and carbon dioxide that are much greater than those found in the surrounding air. Therefore, molecules of methane and carbon dioxide will diffuse from the landfill gas to the air in accordance with Fick's law. Diffusion plays a much smaller role in gas migration than convection.

Many factors affect gas migration. Some of the more important factors are the landfill design, including refuse cell construction; final cover design; and incorporation of gas migration control measures. Low hydraulic conductivity soil layers and geomembranes are very effective barriers to gas migration. Sand and gravel layers and void spaces provide effective corridors for channeling gas migration. Other channels affecting migration are cracks and fissures between and in lifts of waste or soil due to differential settlement and subsidence.

Other factors affecting gas migration include the gas production rate, the presence of natural and artificial conduits and barriers adjacent to the landfill, and climatic and seasonal variations in site conditions. High gas production rates increase migration. Corridors at the site adjacent to a landfill such as water conduits, drain culverts, buried lines, and sand and gravel lenses, promote uncon-

trolled migration from the site. Barriers can include clay deposits; high or perched water tables; roads; and compacted, low hydraulic conductivity soils. Environmental variations can result from the intermittent occurrence of saturated or frozen surface soils, which seals the surface and promotes lateral migration. Barometric pressure changes also affect the rate of gas release to the surface. Seasonal changes in moisture content can change the gas production rate and, therefore, the extent and quantity of migration.

### GAS CONTROL STRATEGIES

Two gas control strategies—passive and active—are available, and may be used at any facility. Passive systems provide corridors to intercept lateral gas migration and channel the gas to a collection point or a vent. These systems use barriers to prevent migration past the interceptors and the perimeter of the landfill. Active systems generate a zone of negative pressure to increase the pressure gradient and, consequently, the flow toward the zone. Active systems also can be used to create a zone of high pressure to prevent gas migration toward the zone.

Typical passive systems are shown in Figures 10-1, 10-2, 10-3, and 10-4. Figure 10-1 shows a gas-vent layer used in conjunction with a composite liner and vent in the cover system (2). The composite liner prevents uncontrolled vertical migration, while the gas-vent layer intercepts all vertical migration and directs it to the vent. Figure 10-2 shows a gravel vent that runs diagonally down through the waste material. The gravel vent intercepts both vertical and lateral migration and channels it to the surface. Figures 10-2, 10-3, and 10-4 show gravel-

filled trenches (1, 3, 4). The trenches intercept lateral migration and direct the gas to the surface where it is vented or extracted. Gravel-filled trenches on the perimeter of the landfill are often used with an impermeable barrier on the outer side of the trench to prevent migration from the trench to the surrounding area. These systems often extend from the surface down to a low hydraulic conductivity soil layer or other barrier such as the water table or a geomembrane. The systems may be as deep as the bottom of the landfill, or even lower if outside the landfill. Extreme care should be taken in the design of all of these vent systems to prevent them from being a source of infiltration through the cover. Improper design could allow the vent to intercept surface runoff and pipe additional infiltration into the leachate collection system.

Typical active systems are shown in Figures 10-4, 10-5, and 10-6 (4). All three figures show gas extraction wells using exhaust blowers. The well is placed in a gravel vent or gravel-filled trench located in the waste cell (Figures 10-5 and 10-6) or along its perimeter (Figure 10-4). The gravel vent is sealed to prevent the well from drawing air from the surface and destroying the suction (zone of negative pressure) needed to draw gas to the well. The seal also prevents infiltration of surface water. Impermeable barriers in the cover and perimeter walls increase the efficiency of gas extraction wells since they restrict inflow of air that would dissipate the suction. In addition, it reduces the number of wells needed and increases the heating value of the gas collected. Typically, gas extraction wells do not extend to the bottom of the landfill since the suction is able to draw gas from a sizable zone beyond the gravel fill.

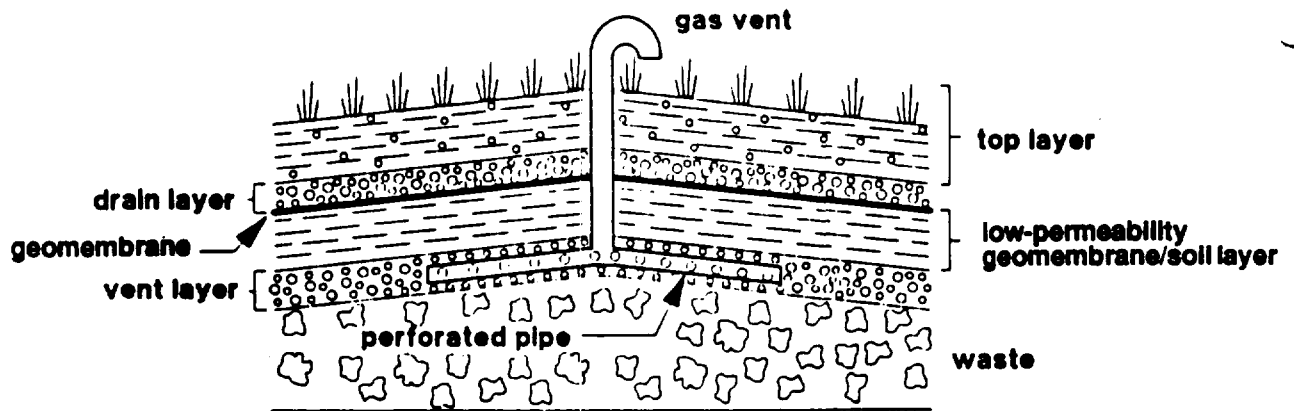

Figure 10-1. Cover with gas vent outlet and vent layer.

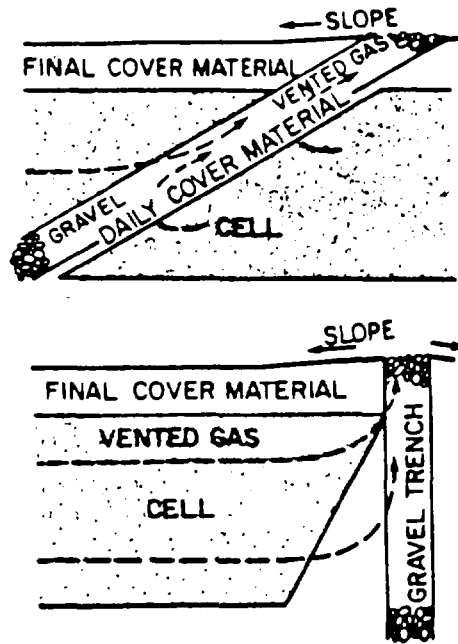

Figure 10-2. Gravel vent and gravel-filled trench used to control lateral gas movement in a sanitary landfill (5).

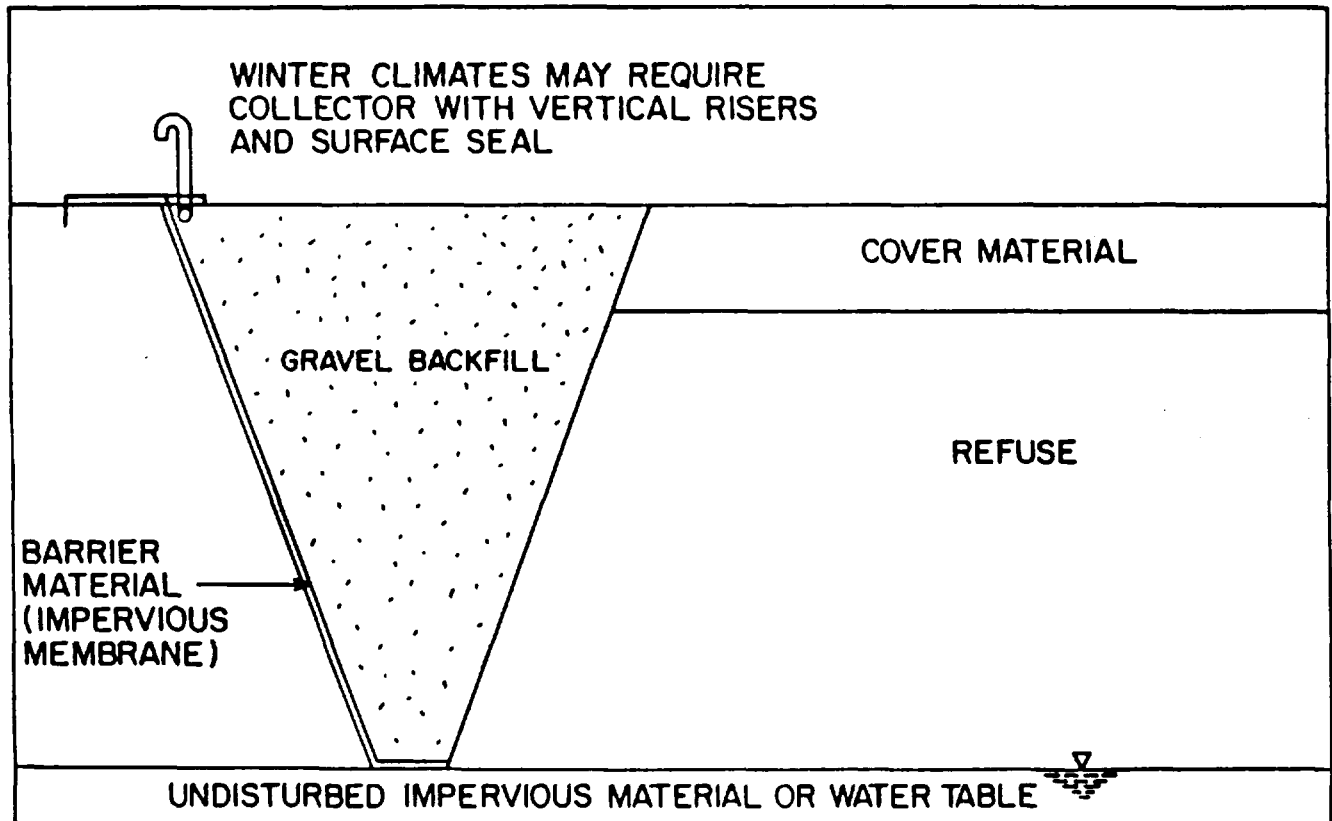

Figure 10-3. Typical trench barrier system.

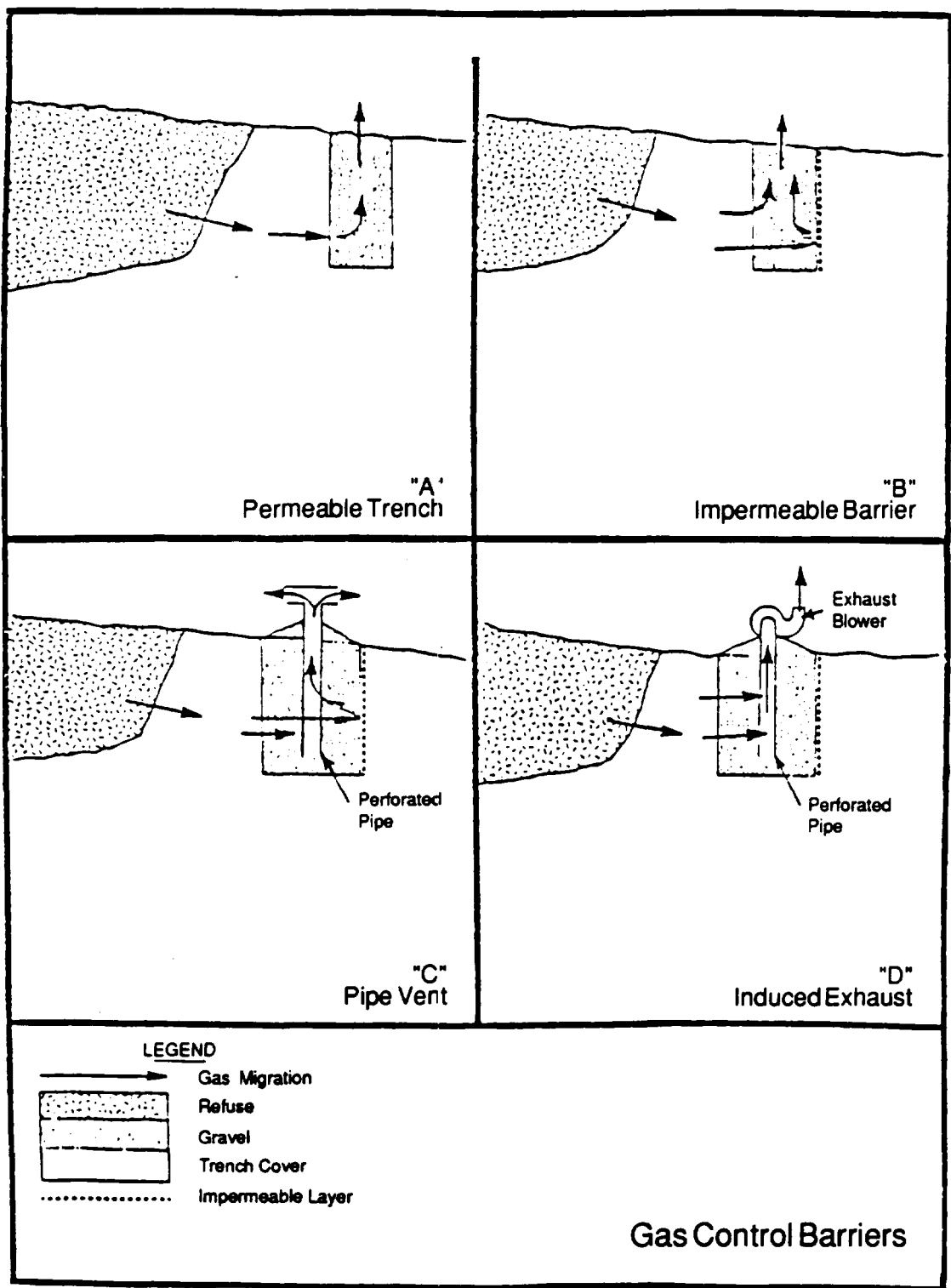

Figure 10-4. Gas control barriers (6).

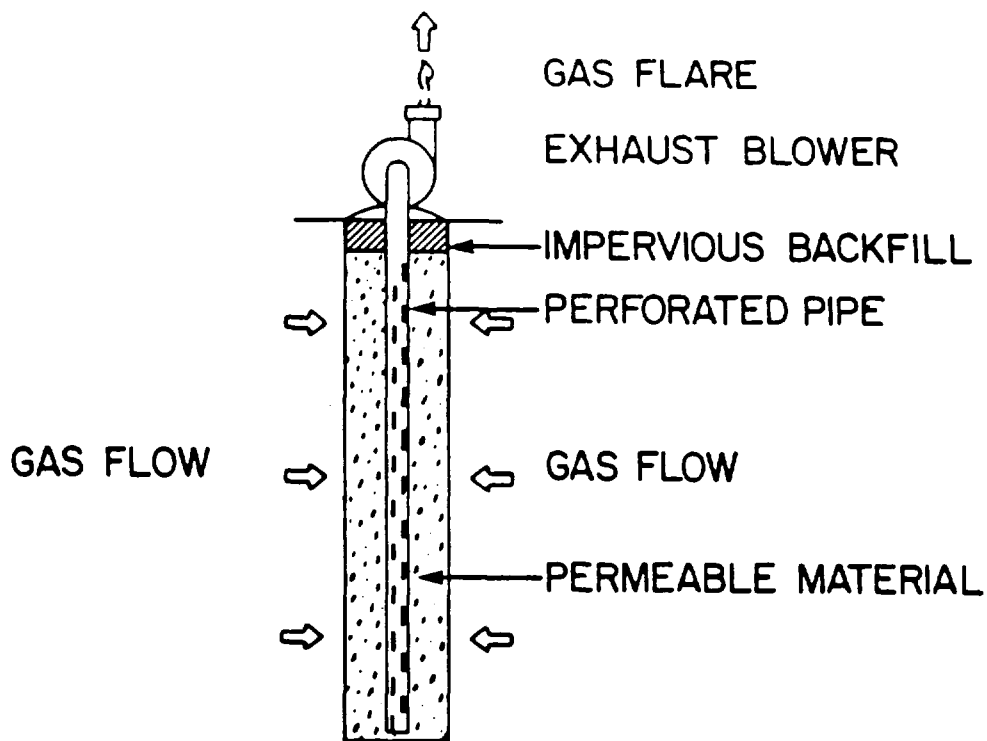

Figure 10-5. Gas extraction well for landfill gas control.

#### REFERENCES

1. Lutton, R.J., G.L. Regan, and L.W. Jones. 1979. Design and construction of covers for solid waste landfills. EPA-600/2-79-165 U.S. EPA Municipal Environmental Research Laboratory, Cincinnati, OH.
2. U.S. EPA. 1989. Technical guidance document: final covers on hazardous waste landfills and surface impoundments. EPA/530-SW-89-047.
3. Shafer, R.A., A. Renta-Babb, J. T. Bandy, E. D. Smith, and P. Malone. 1984. Landfill gas control at military installations. Technical Report N-173. U.S. Army Engineer Construction Engineering Research Laboratory, Champaign, IL.
4. McAney, C.C., P.G. Tucker, J.M. Morgan, C.R. Lee, M.F. Kelley, and R.C. Horz. 1985. Covers for uncontrolled hazardous waste sites. EPA/540/2-85/002 U.S. EPA Hazardous Waste Engineering Research Laboratory, Cincinnati, OH.
5. Brunner, D.R. and D.J. Keller. 1971. Sanitary landfill design and operation. SW-66TS. U.S. Environmental Protection Agency.
6. Rovers, F.A., J.J. Tremblay, and H. Mooij. 1977. Procedures for landfill gas monitoring and control. EPS 4-EC-77-4, Waste Management Branch, Environment Canada, Ottawa.

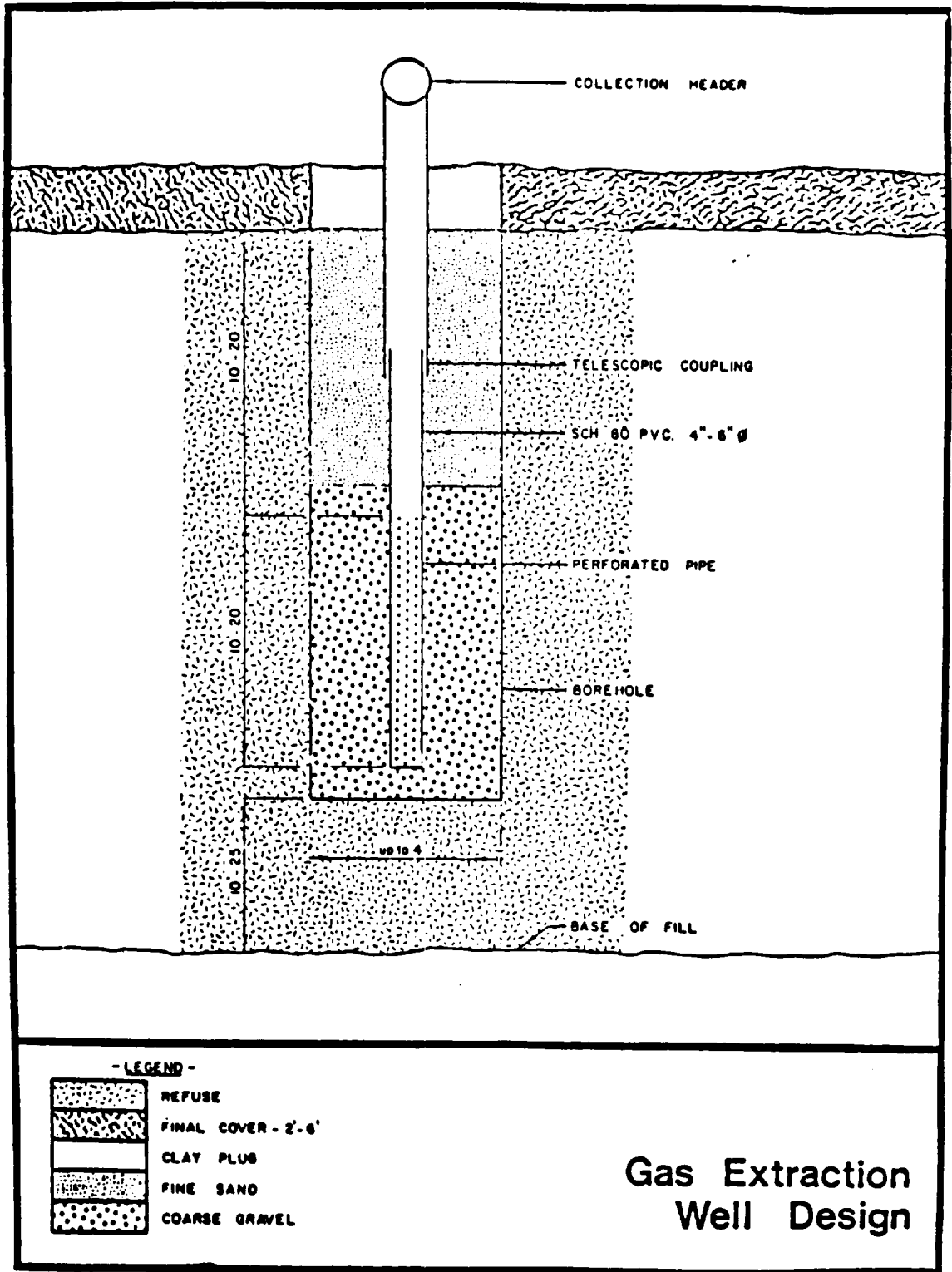

Figure 10-6. Gas extraction well design (6).

## CHAPTER 11

### CASE STUDIES — RCRA/CERCLA CLOSURES

#### INTRODUCTION

This chapter presents five waste closure case studies. Each study examines both design details that confirm the suitability of the individual cap and those that may detrimentally affect the long-term service of the facility. The first four caps have been permitted and placed over RCRA/CERCLA wastes. The fifth cap has been proposed for a major municipal solid waste (MSW) landfill and demonstrates the design problems that may be associated with such facilities.

Each design example is intended to highlight problems that may be encountered in satisfying all aspects of general closure criteria. The criteria that must be satisfied are:

1. Specific minimum technology guidance (1) (MTG) applicable or appropriate and relevant to the site-specific waste. MTG is discussed in greater detail in Chapter 1.
2. Erosion control to limit the loss of cover soil to less than 2 ton/acre/year, as discussed in Chapters 1 and 8.
3. Gas control systems to minimize movement of waste-generated gases off site.
4. Ability for all systems to survive both local and global subsidence potentials, as discussed in Chapters 1 and 2.

This chapter also raises specific concerns regarding the use of MTG guidance blindly, without engineering confirmation of its suitability.

#### CASE 1: RCRA COMMERCIAL LANDFILL

The first closure case presents a cap over a commercial hazardous waste disposal cell that is designed to satisfy the basic MTG cap profile. Figure 11-1 shows details of the general cap profile and geometry. Note that the slope of the cap does exceed the 5 percent maximum contained in the MTG criteria but is significantly flatter than the caps on the other examples. The use of low slopes on such facilities recognizes that the solidified waste placed within them is very stable and will not produce significant long-term subsidence. Such low slopes cannot be used in

applications where high long-term subsidence is a concern, such as with many CERCLA and MSW closures. This chapter examines two significant design considerations for such facilities: 1) calculation of localized subsidence and its impact on the cover barrier layer, and 2) the impact of gas collection systems.

#### *Calculation of Localized Subsidence*

During the service life of this facility, it received nearly 10,000 transformers containing PCB oils (TSCA permitted). The regulator expressed concern about the long-term impact of the loss of oil and eventual collapse of the transformer cases. Fortunately, available records provided the location and size of the transformers. The general subsidence model used to predict the surface displacement of the cap due to transformer collapse was adapted from an EPA study by Murphy and Gilbert (2) (see Figure 11-2). The key assumption in this model is that the volume of the surface depression is equal to the volume of the oil leaking from the transformer. This is a conservative assumption because it neglects the arching that will occur within both the waste and operational soils placed around the waste. An additional key assumption must be made regarding the friction angle of the waste itself. For this case, the friction angle was assumed to be that of the operational soils placed around the waste. For wastes in general, such values can be measured in actual field tests (3).

The simple model for subsidence due to a single transformer collapse then must be applied to the actual cover for all 10,000 transformers. The subsidences are accumulated and plotted as shown on Figure 11-3. By examining the cap's elevation contour, one can estimate the maximum long-term relative vertical displacement of the cap. For this case, the maximum relative displacement is approximately 0.5 m in 6 m (1.8 ft in 20 ft.)

Calculation of the maximum vertical relative displacement is important only if the designer can estimate the impact of such displacement on the site-specific cap profile. MTG barrier systems consist of a geomembrane and a clay layer, both of which must be separately evaluated for strain. The strains in the geomembrane can be estimated using one of two models, depending on the type of anticipated subsidence.

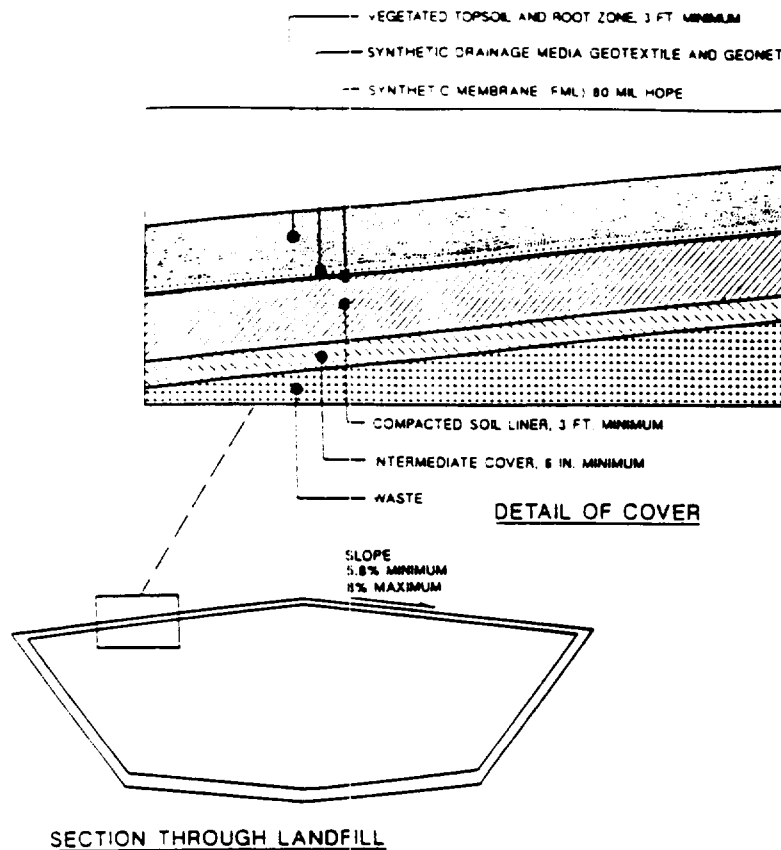

Figure 11-1. Case 1—Cap profile and geometry.

For *trench-like subsidence*, the strains can be calculated using the model shown in Figure 11-4. The maximum strain that the geomembrane can tolerate in such a plane strain condition is given by the uniaxial test data commonly reported by geomembrane manufacturers (see Figure 11-5).

For *spherical-type subsidence*, the strains in the geomembrane can be calculated using the method discussed in Chapter 3 of this manual. For such an assumed failure mode, the designer must compare the predicted strain with the ultimate strain limit of the geomembrane, as obtained from biaxial testing (see Figure 11-5). Chapter 3 gives additional data on typical ultimate strains of common geomembranes in biaxial loading. Most geomembranes can easily tolerate vertical differential settlement of the cover in excess of 0.9 m in 3 m (3 ft in 10 ft) of run. This results in a factor of safety based on an ultimate strain of 3.3 for the geomembrane in Case 1.

The strain in the soil component of the barrier can be estimated using the chart in Figure 11-6. The specific ultimate tensile strain of the onsite soil can be evaluated in a triaxial Consolidated Isotropic Undrained (CIU) test or can be estimated from the chart in Figure 11-7. For this

particular soil barrier, the ultimate relative strain allowable under this criteria is 0.4 m in 3 m (1.2 ft in 10 ft) of run. This results in a factor of safety of 1.33 for the clay component in Case 1. If the settlements are occurring over an extended length of time, this low factor of safety may be acceptable due to the ability of a clay to creep. The creep deformation of the clay allows long-term strains to develop in the layer without a comparable increase in stress. This is commonly referred to as "stress relaxation."

### Gas Collection Systems

Commercial hazardous waste facilities generate minimal gas due to the solidified nature of the waste. Typically, gas collection systems for such facilities are simple linear French drain collectors, as shown in Figure 11-8.

Extreme caution must be exercised in designing gas removal systems for wastes that have a long anticipated lifetime. A gas removal system is a very efficient vehicle for surface water to gain access to the waste if the vent pipes become damaged. Thus, if long-term maintenance of the cap cannot be assured, a gas collection system may eventually cause failure of the cap to perform its primary function—preventing surface water from reaching the waste. Provisions should be made in the permit of

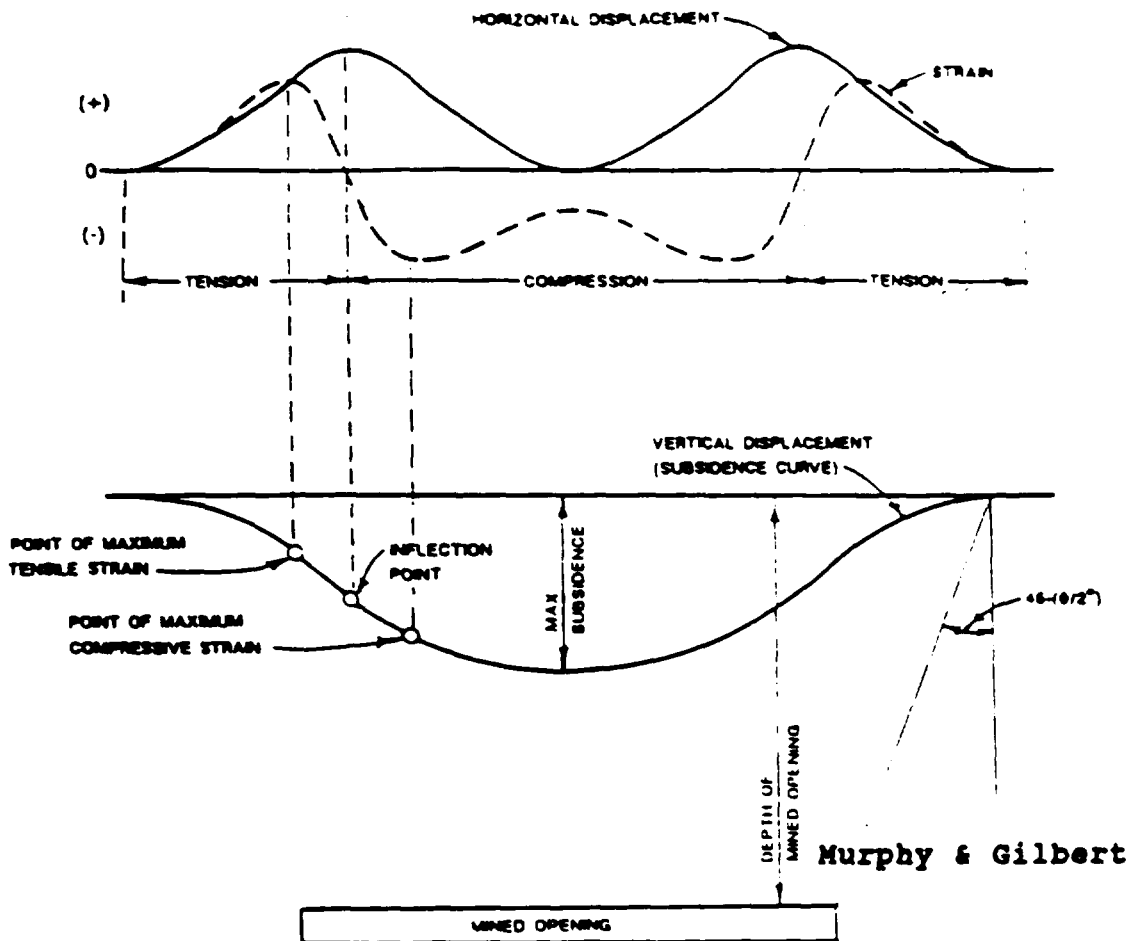

Figure 11-2. Case 1—General subsidence model.

such facilities for removing and sealing the gas vents if postclosure monitoring indicates that no appreciable quantities of gas are being generated.

As a final comment, the HELP analysis (see Chapters 8 and 9) for such caps must assume an effective leakage for the geomembrane component of the barrier. This leakage is commonly calculated by assuming from 9 to 13 penetrations (1 cm) per acre in the geomembrane. The leakage through such penetrations can then be calculated using the following equation (5):

$$Q = 3 a^{0.75} h^{0.75} K_d^{0.5}$$

- where
- Q = steady-state leakage rate (M<sup>3</sup>/sec)
  - a = area of hole (M<sup>2</sup>)
  - h = head of leachate (M)
  - k = permeability of underlying soil (M/S)

A revised version of HELP is being developed that will accept such penetration data directly.

## CASE 2: RCRA INDUSTRIAL LANDFILL

The second case study shows a cap profile that is becoming increasingly common in Europe and the United States due to the high cost per acre of composite lined landfills. As shown in Figure 11-9, the cap has two significant profiles: a steep perimeter that provides for the volume of the facility and a flatter top that covers the majority of the waste. Figure 11-9 also shows a detail of the cap profile which is a typical MTG profile. The key design problems for this case involve the steep perimeter of the cap, including both the sliding stability of such covers and the erosion resistance of their protective surface.

The slope stability of covers, or liner systems, containing geosynthetic layers is typically of concern if the slope exceeds 8 degrees. The three horizontal to one vertical (3H:1V) slopes of the perimeter are 18.4 degrees and, therefore, of concern. The stability of cover and liner systems on such slopes is evaluated by performing laboratory direct shear tests on each suspect interface to determine the minimum factor of safety against sliding

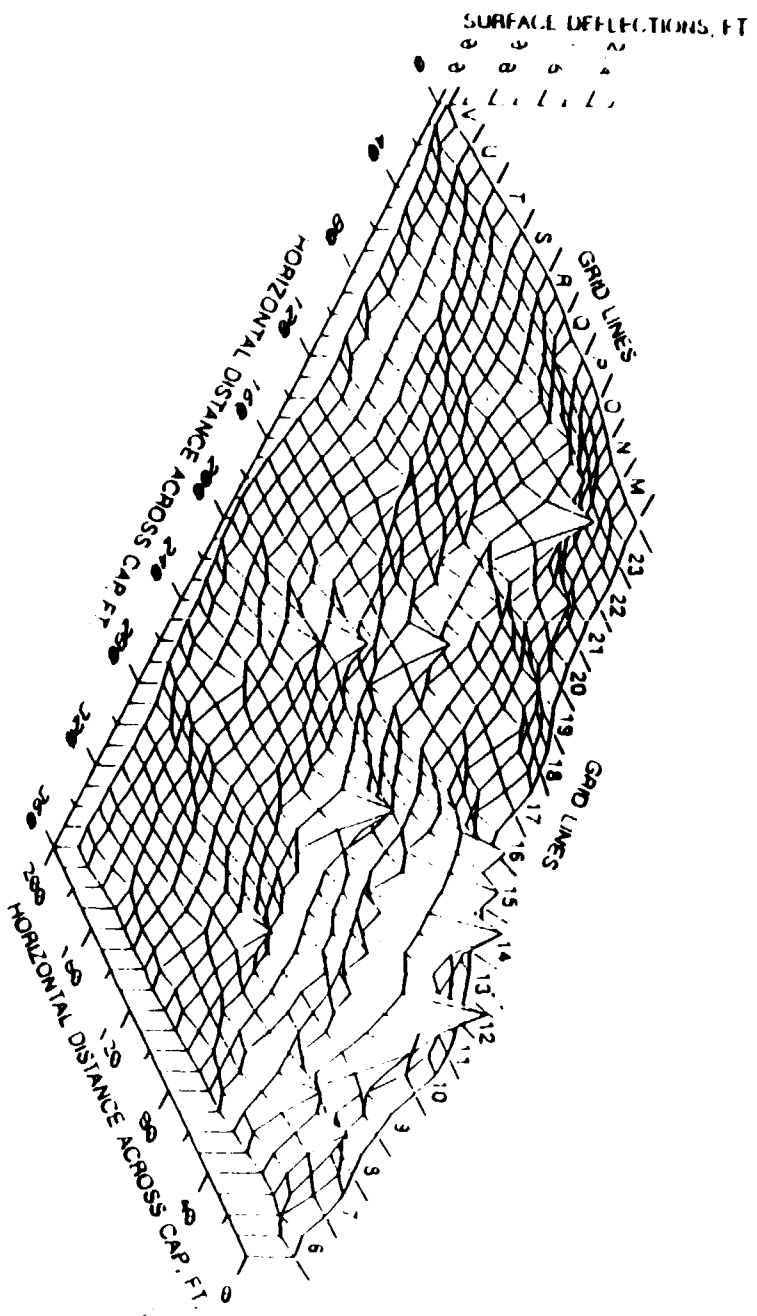
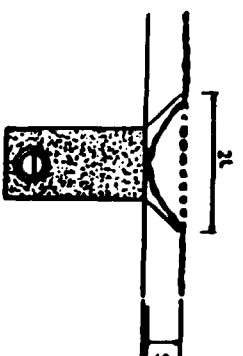
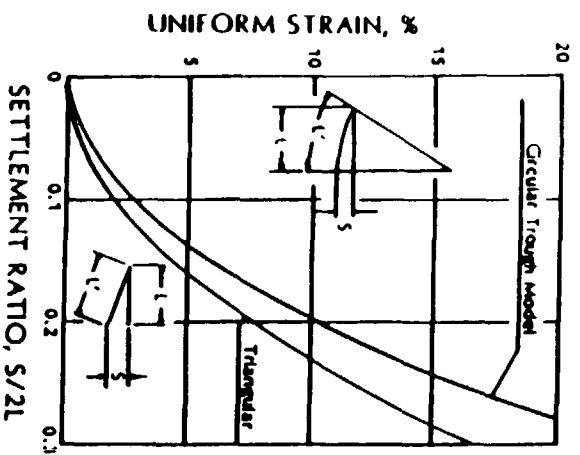

Figure 11-3. Case 1—Cumulative subsidence.



(Knapenheid, 1985)

Figure 11-4. Case 1—Geomembrane strains in trench subsidence.

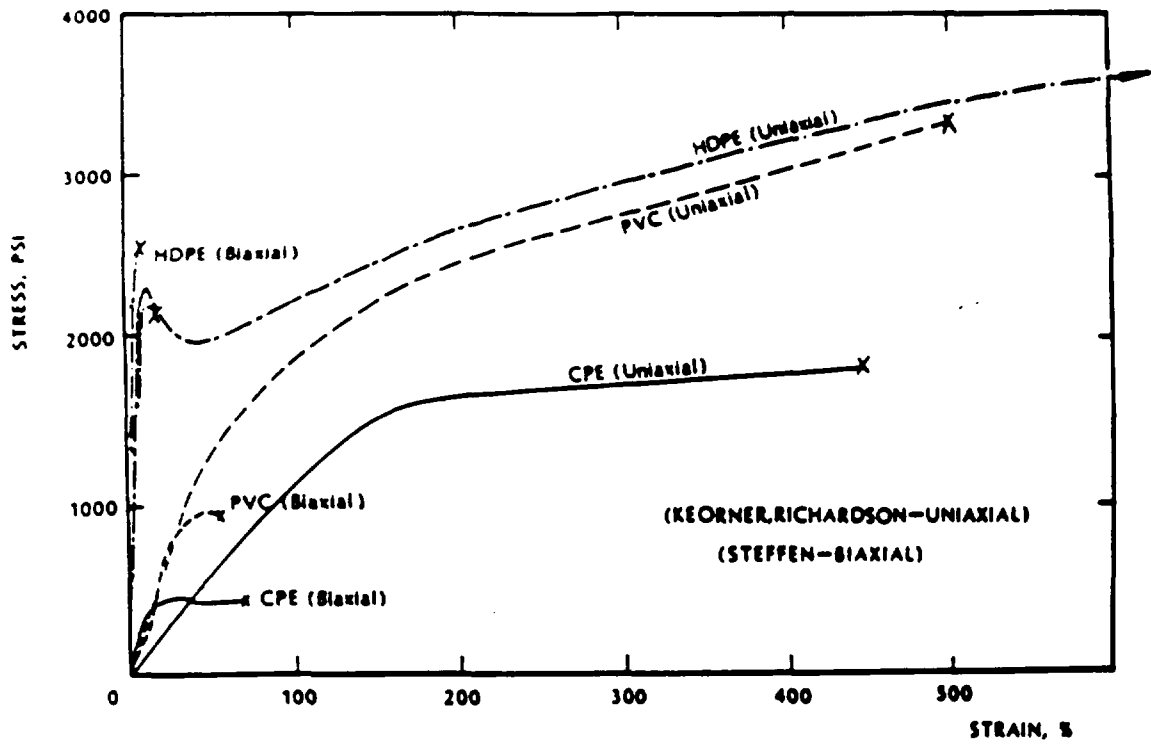
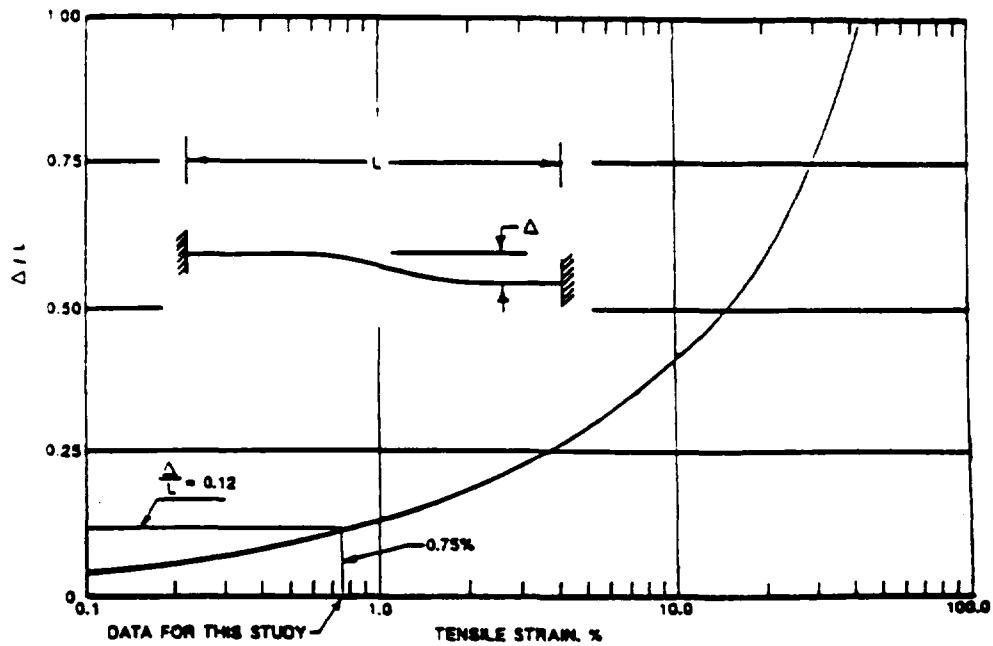

Figure 11-5. Case 1—Uniaxial and biaxial geomembrane response.



Index of maximum settlement  $\Delta/L$  vs tensile strain (after Gilbert and Murphy, 1987)

Figure 11-6. Case 1—Subsidence strain in soil barrier.

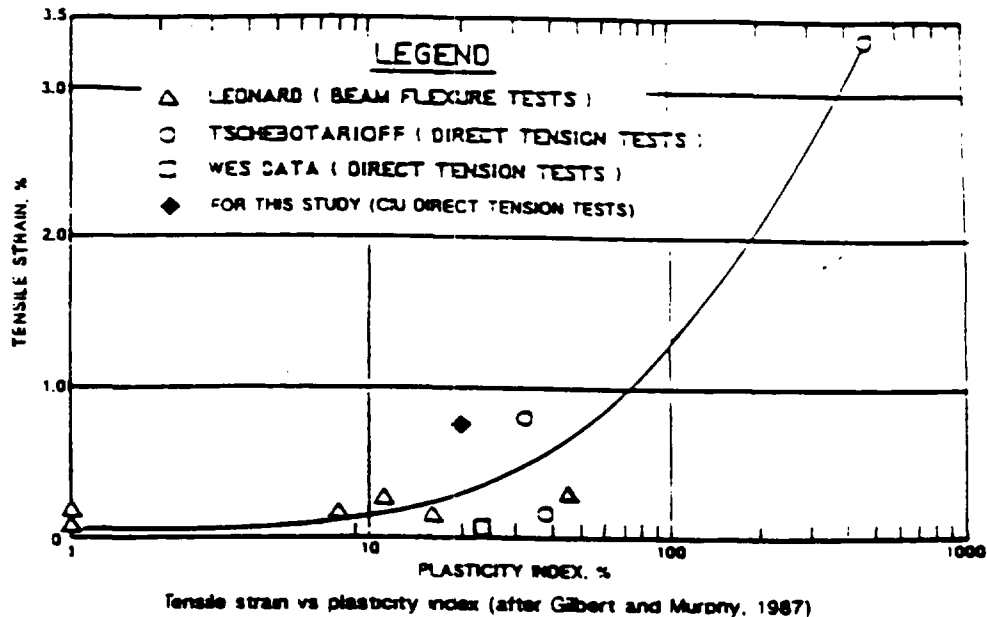

Figure 11-7. Case 1—Ultimate tensile strain in clays.

This testing procedure is described in greater detail in Chapter 3 (pp. 3-4) and Appendix A. Steep covers requiring a geomembrane commonly use three liner/drainage layer profiles to provide a stable slope:

1. A textured HDPE or VLDPE geomembrane with either a sand drainage layer or a drainage layer formed using a geonet with filter fabric bonded to both faces.
2. A geomembrane having nonwoven geotextiles bonded to both faces and a sand drainage layer.
3. A smooth geomembrane, sand, or geonet drain, with an added geogrid reinforcement in the cover soil layer to hold the layer on the slope.

The first two alternatives are examined for this case; Case 3 discusses the third alternative.

Figure 11-10 shows direct shear data for the first alternative. Because the nonwoven material used in the bonded geomembrane will develop the full shear strength of the adjacent soil, direct shear tests are not commonly performed for this material. Therefore, with both the tested textured and bonded geomembrane, the minimal interface friction angle will be significantly greater than the 18.4 degree sideslope angle. It must be noted that such interface friction angles must be verified in laboratory testing; not all textured geomembranes are effective.

The owner/operator must use caution in interpreting direct shear data from evaluations of interface friction angles. A recent full-scale field test of various cover profiles demonstrated that the interface friction angle is very dependent on the normal force acting on the layers (6).

Thus, direct shear data from tests for cap design using low normal loads should not be used for designing liner interfaces where high normal loads are anticipated. This dependency also makes the use of interface friction angles obtained from the literature very suspect. Laboratory direct shear tests should be performed using the soils, geosynthetics, and normal loads associated with the site-specific conditions.

The steep perimeter slopes must be verified as satisfying the MTG criteria of a cover soil loss of less than 2 tons/acre/year. The rate of soil loss is verified using the Universal Soil Loss Equation (USLE) given by:

$$A = RKLSCP$$

- where
- K = soil erosion factor from Table 11-1
  - LS = slope constant from Figure 11-11
  - R = rainfall and runoff index
  - C = cover management factor
  - P = practice factor, 0.3 to 1.0

EPA proposed a procedure to calculate an effective LS factor for caps having two distinct slopes, as found in this case (7). This method, however, is not currently recommended because it underestimates true soil loss. For caps having two very distinct slopes, it is more effective to evaluate each slope independently and to provide a runoff collection ditch, e.g., swale, between the slopes to hydraulically disconnect these features in the field. Thus, the 3H:1V perimeter slopes of Case 2 should be evaluated using their maximum slope length and full

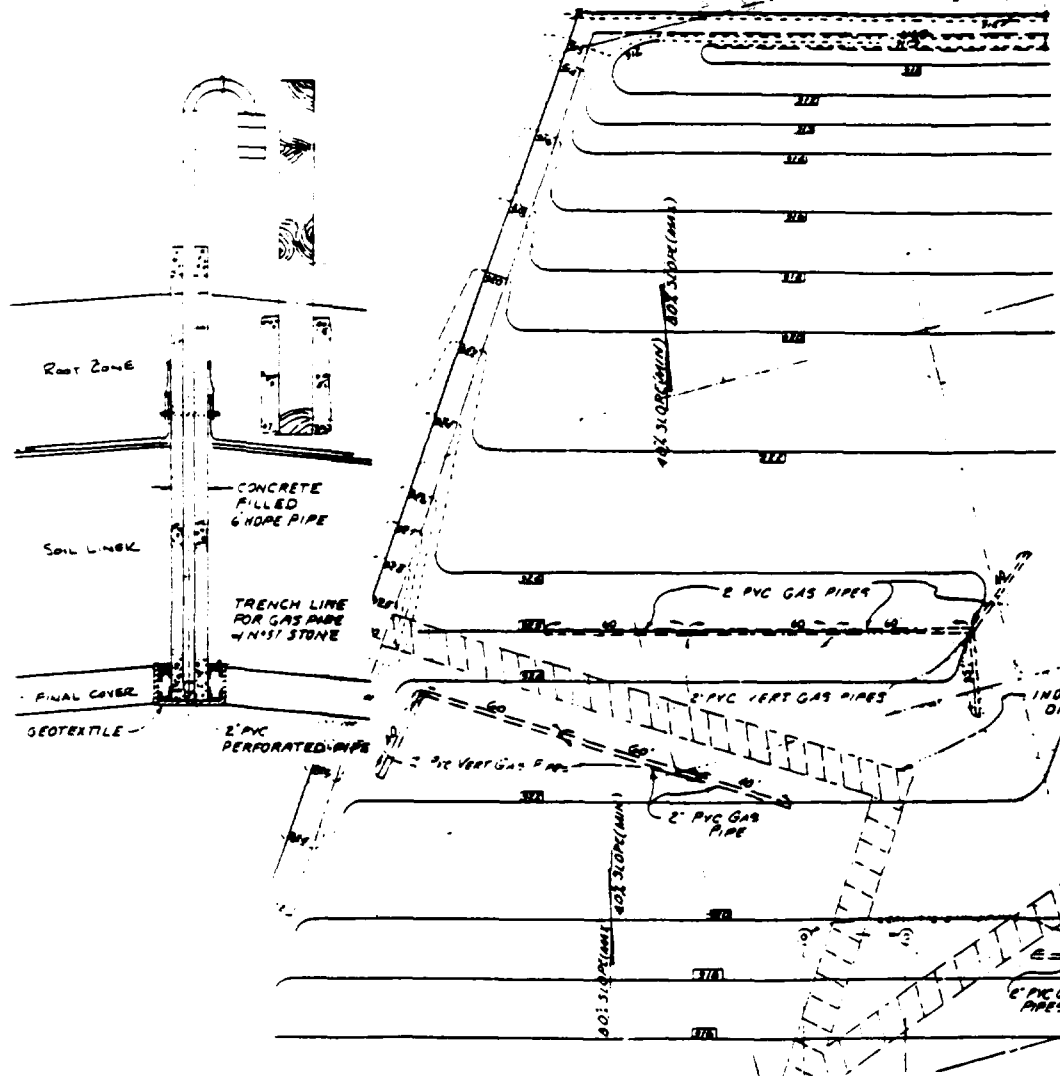

Figure 11-8. Case 1—Gas collector system.

slope angle. Calculations of annual soil loss for the 3H:1V side slopes were performed using the following values for the USLE variables:

- R = 140—from local SCS
- K = 0.3, sandy loam from Table 11-1
- C = .006—from local SCS
- P = 1.0, maximum value
- L = slope length = 15 m (50 ft)
- S = slope = 3H:1V = 33 percent

These values and the LS topographic factor obtained from Figure 11-11 yielded an annual soil loss of 1.8 tons/acre/year, which is acceptable.

Caps having two distinctive slopes may be designed using two distinctive methods of cover protection.

Figure 11-12 shows one early scheme that incorporated an armoring cover of coarse gravel on the steeper slope. In this example, a swale is not provided between the slopes due to the high transmissivity value of the gravel. In general, however, such slopes should be separated by a swale to make them hydraulically independent.

### CASE 3: CERCLA LAGOON CLOSURE

In this case, sediments from three industrial settling lagoons were consolidated to a single mound, as shown in Figure 11-13. The sediments contained RCRA constituents, but the age of the waste and the use of existing lagoons for the consolidated facility made RCRA MTG not applicable. The nature of the sediments and general site conditions, however, made RCRA MTG appropriate and relevant (see Chapter 1). Thus, the cap for the consolidated sediment mound is essentially an MTG cap

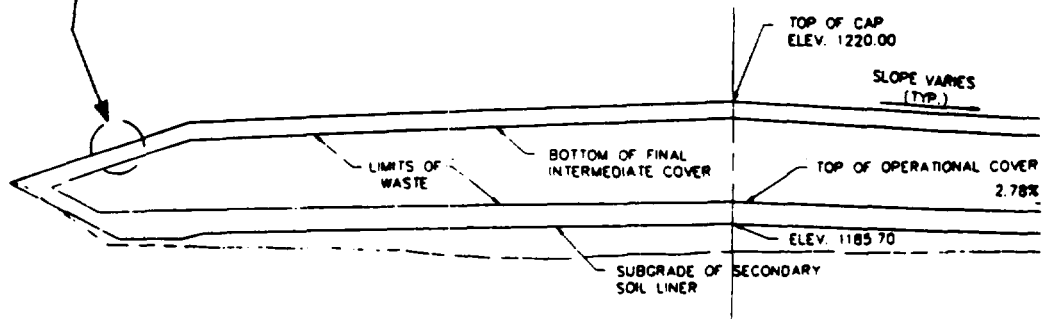
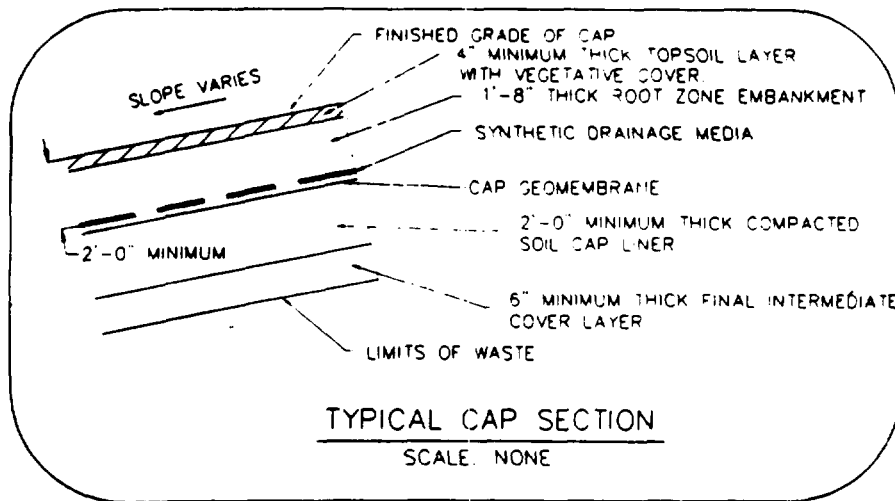

Figure 11-9. Case 2—Cap profile and geometry.

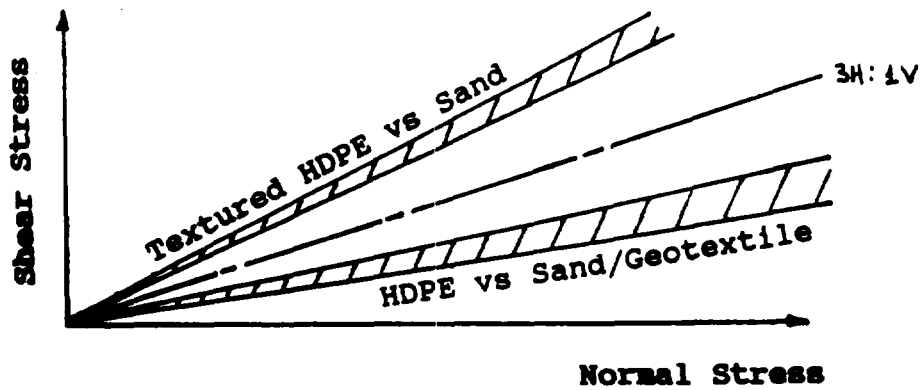
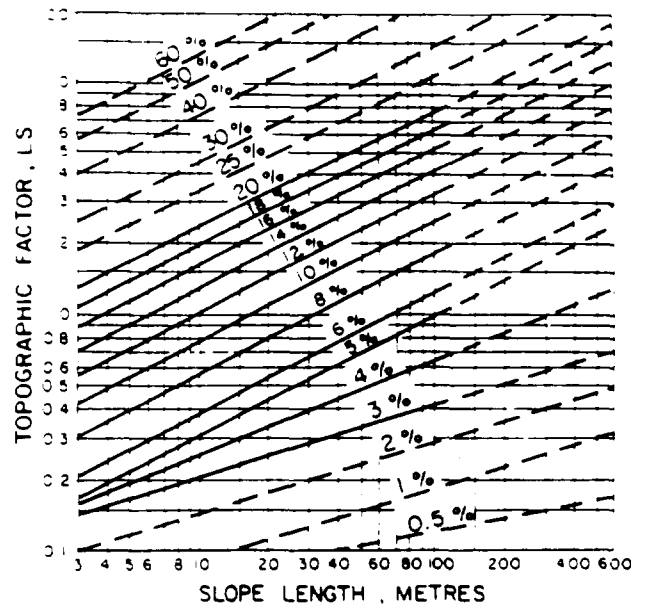

Figure 11-10. Case 2—Direct shear data: texture HDPE.

**Table 11-1. Soil Texture Constant for Soil Loss Evaluation**

Texture class	Organic matter content		
	< 0.5 per cent	2 per cent	4 per cent
	K	K	K
Sand	0.05	0.03	0.02
Fine sand	0.16	0.14	0.10
Very fine sand	0.42	0.36	0.28
Loamy sand	0.12	0.10	0.08
Loamy fine sand	0.24	0.20	0.16
Loamy very fine sand	0.44	0.38	0.30
Sandy loam	0.27	0.24	0.19
Fine sandy loam	0.35	0.30	0.24
Very fine sandy loam	0.47	0.41	0.33
Loam	0.38	0.34	0.29
Silt loam	0.48	0.42	0.33
Silt	0.60	0.52	0.42
Sandy clay loam	0.27	0.25	0.21
Clay loam	0.28	0.25	0.21
Silty clay loam	0.37	0.32	0.26
Sandy clay	0.14	0.13	0.12
Silty clay	0.25	0.23	0.19
Clay		0.13-0.29	

\* The values shown are estimated averages of broad ranges of specific-soil values. When a texture is near the borderline of two texture classes, use the average of the two K values. For specific soils, use of Figure 2.6 or Soil Conservation Service K-value tables will provide much greater accuracy. From A.R.S. 1975



**Figure 11-11. Case 2—Slope factors for soil loss evaluation.**

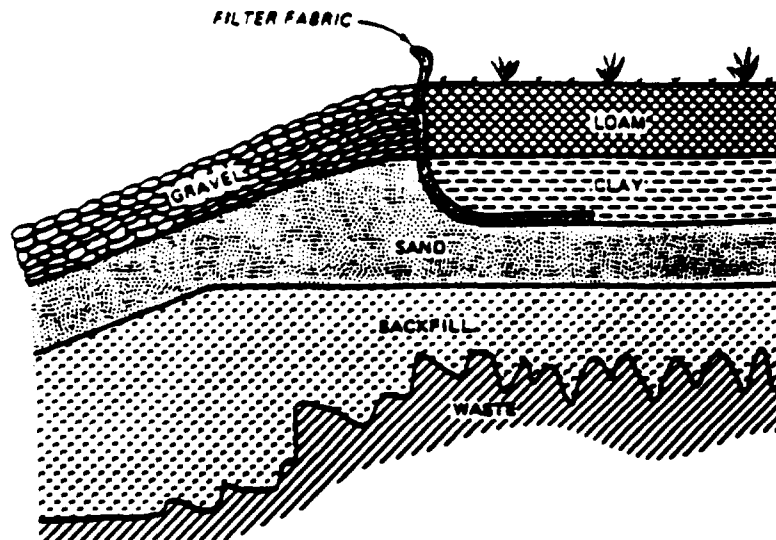

**Figure 11-12. Case 2—Slideslope armoring scheme.**

(see Figure 11-13). A key variation, however, is the use of a commercial bentonite board in place of the compacted clay component of the composite barrier system.

As in Case 2, the combination of steep slopes and geosynthetic interfaces made slope stability a concern for this cap. Direct shear tests of the geosynthetic interfaces indicated that the governing interface was between the PVC geomembrane and the geotextile forming the surface water of the bentonite board. Additionally, as the bentonite board hydrates, it loses significant shear

strength. In general, the hydrated bentonite board is not stable on slopes steeper than 9 degrees. To ensure stability of the drainage layer and cover soil, the design incorporated geogrid soil reinforcement into the cap. Chapter 3 discusses the calculations required to confirm the ability of the geogrid. It is important that the strain assumed in selecting available geogrid tensile strength be small enough that excessive elongation of the geogrid does not occur. The 5 percent strain assumed in this Case 3 analysis is the maximum strain that should be used.

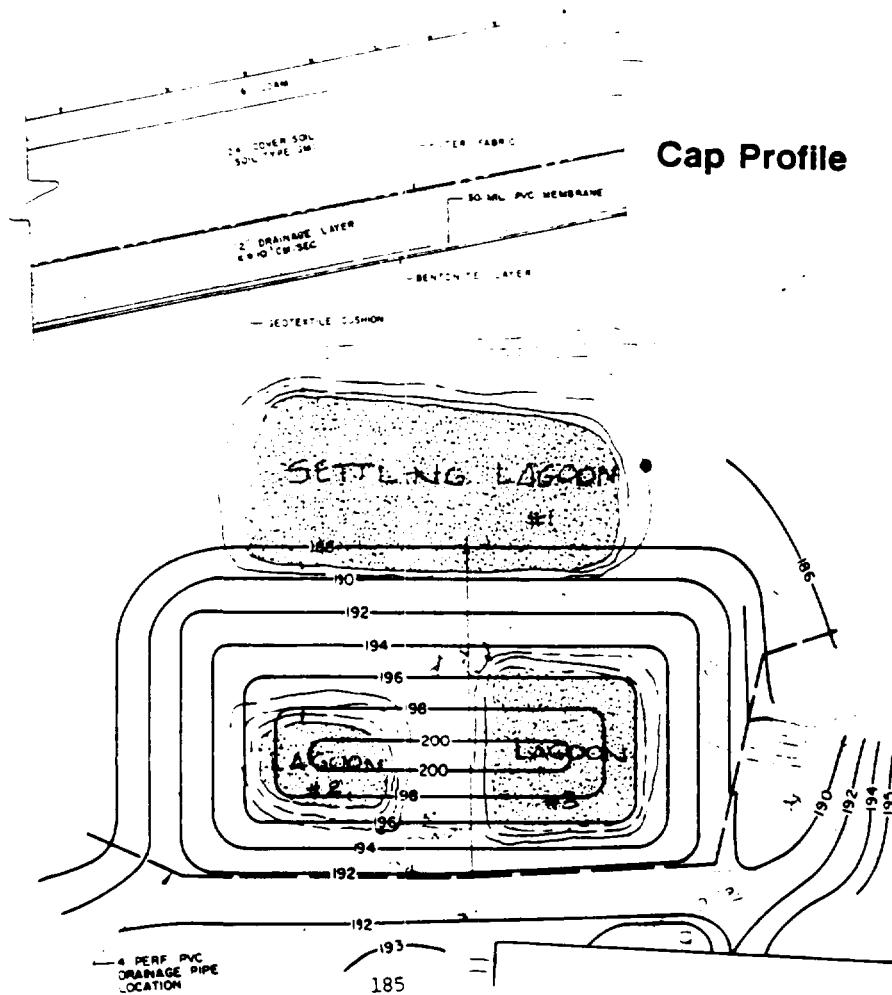

Figure 11-13. Case 3—Cap profile and geometry.

In addition to having sufficient tensile strength, the geogrid must be anchored sufficiently to develop this strength. It cannot be anchored using an anchor trench without impinging on the waste. The geogrid in Case 3, therefore, is anchored by running the grid continuously over the cap and counterbalancing the weights of the cover soils on opposing faces. While this procedure is technically simple, it restricts construction significantly; the cover soil and drain must be placed in a symmetrical manner, preferably from the top down, to tension the geogrid. Figure 11-14a shows the geogrid being placed over the geomembrane, and Figure 11-14b shows the drain layer being placed on top of the geogrid.

Water collected in the surface water drainage layer must be allowed to freely leave that system to avoid building up head on the liner, and to maintain stability. Figure 11-15a shows the sideslope toe drainage detail used in Case 3. From a long-term maintenance standpoint, this drainage system is very poor. The thin layer of loam topsoil will readily erode at the surface interface with the geotextile

and trap rock, as shown on Figure 11-15b. Surface water drainage layers in caps having significant slopes, such as in Case 3, should outlet using pipe laterals placed at a minimum of one 40-cm (4-in.) drain pipe every 61 m (200 ft) around the perimeter of the surface drain.

#### CASE 4: CERCLA LANDFILL CLOSURE

The fourth case study is of a cover placed over an existing MSW landfill that received 20,000 yd<sup>3</sup> (15,292 m<sup>3</sup>) of baghouse dust containing cadmium, chromium, and lead. The baghouse dust was placed on top of the MSW waste and was, therefore, highly exposed. The landfill itself was adjacent to a community park and the local youths had established biking paths over the landfill. Both the state and the principal responsible party (PRP) wanted to close the landfill in a manner that prevented surface water from reaching the dust and discouraged the recreational use of the cap. For these reasons, they selected a unique hardened cap profile. Such hardened caps do not promote recreational use of the cover and, therefore, do



Figure 11-14a. Case 3—Placement of geogrid over geomembrane.



Figure 11-14b. Case 3—Placement of drainage layer over geogrid.

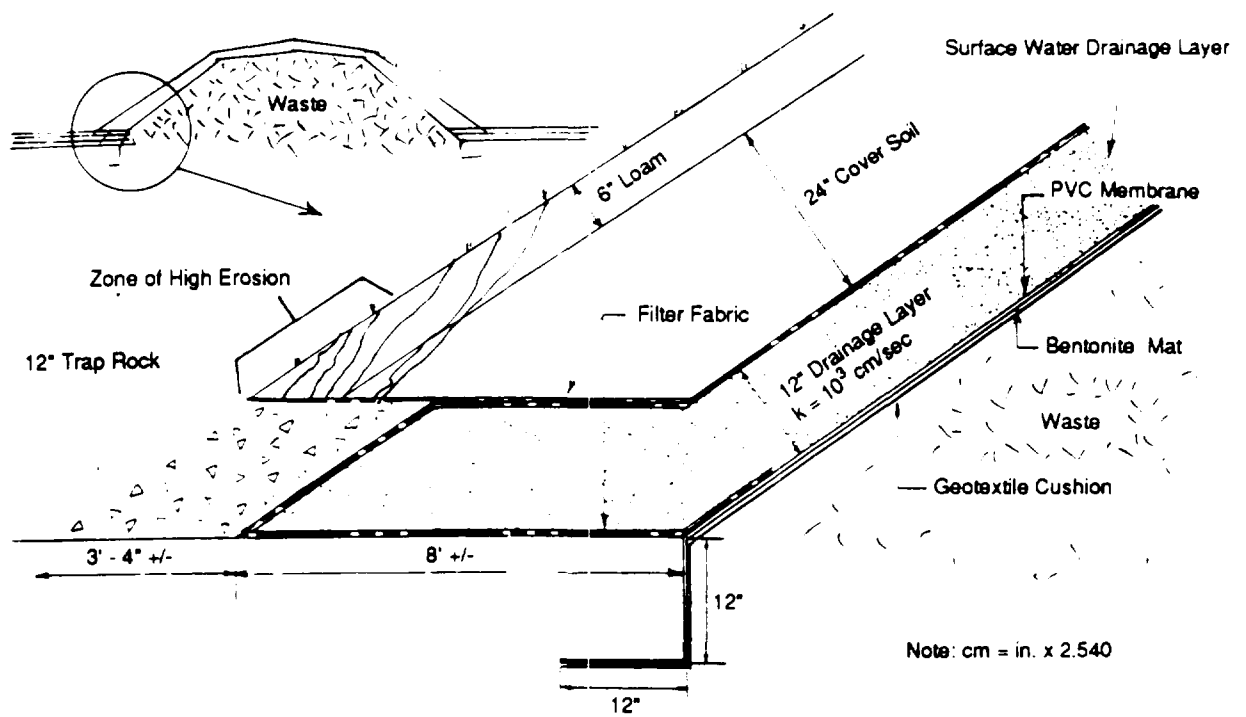

Figure 11-15a. Case 3—Outlet detail for sideslope toe surface water drainage layer.



Figure 11-15b. Case 3—Erosion at drainage layer outlet.

not create an attractive nuisance in terms of maintenance and security. Figure 11-16 shows the final cap profile and contours.

The cap profile is significantly different than the MTG cap in that it uses no drainage or agricultural layers. The asphalt and paving fabric form a unique composite barrier with the compacted clay cap. The chip seal added to the top of the barrier is provided to protect the asphalt and paving fabric from ultraviolet (UV) light degradation, not for erosion control. The "hardened" cap is advantageous since it is not an attractive nuisance, requires very low maintenance, and minimizes the problem of volunteer vegetation.

The geotextile was placed over the asphalt on a surface of asphalt emulsion (see Figure 11-17a). Rolling the fabric over the hot emulsion fully impregnated the geotextile so that it acts as a water barrier. The chip seal placed on top of the geotextile (see Figure 11-17b) is bonded to the geotextile by the emulsion, in a manner similar to an industrial roofing system.

While the hardened cap is low maintenance, it does require an annual inspection and renewal of the chip seal surface every 5 years. Additionally, the perimeter

drainage must be cleaned regularly to promote surface water drainage. Allowable differential subsidence criteria must be established for such caps in the same manner as described for Case 1.

Similar hardened caps have been used on RCRA closures in the Southeast. One particular closure at a Department of Energy facility in Tennessee functions as a parking lot. This particular cap replaced the agricultural layer of the MTG profile with an asphalt and subbase parking surface. While such caps must obviously be inspected on a regular basis, they can offer significant maintenance and land use advantages.

### CASE 5: MSW COMMERCIAL LANDFILL

This last example, Case 5, shows how the basic RCRA/CERCLA closure profiles are being adapted for the more common MSW landfills. The cap profile shown in Figure 11-18 includes a composite barrier layer and a protective/agricultural soil cover. It does not include a drainage layer between the barrier layer and the cover soil. The drainage layer is often omitted in MSW caps. In particular, states such as New York (8) have chosen not to require the drainage layer due to concerns regarding

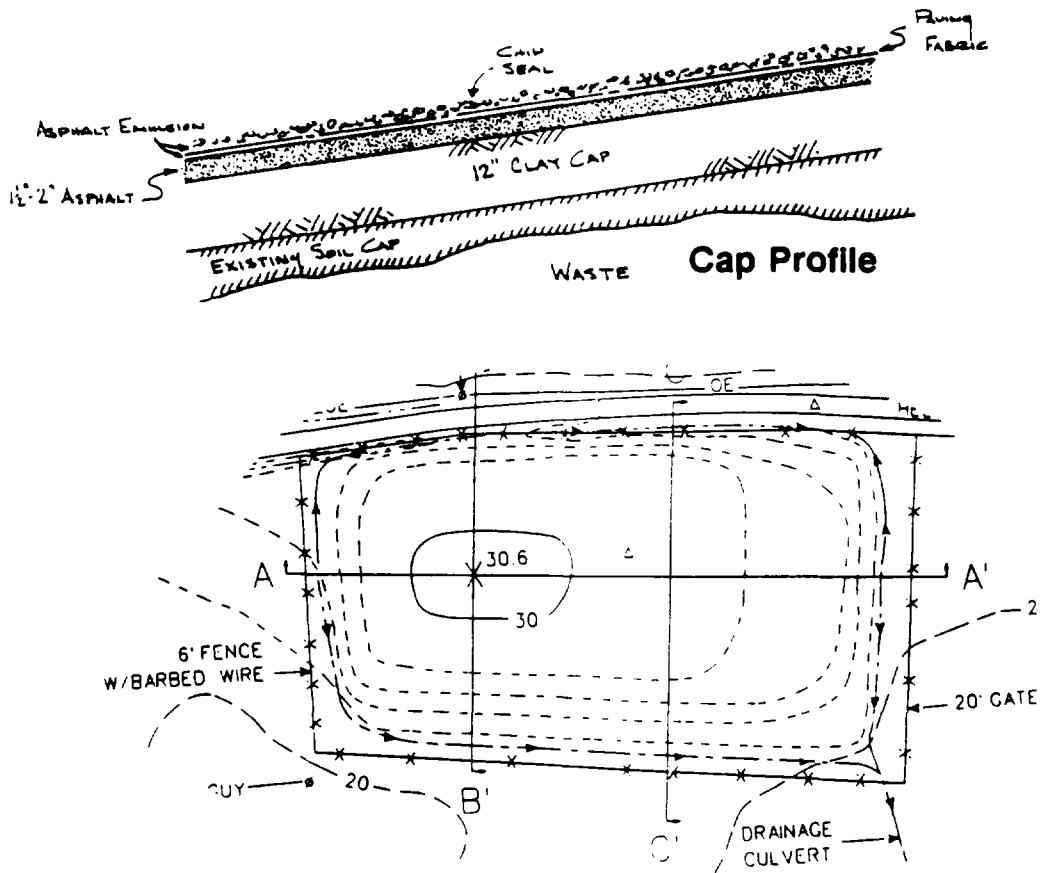

Figure 11-16. Case 4—Cap profile and geometry.

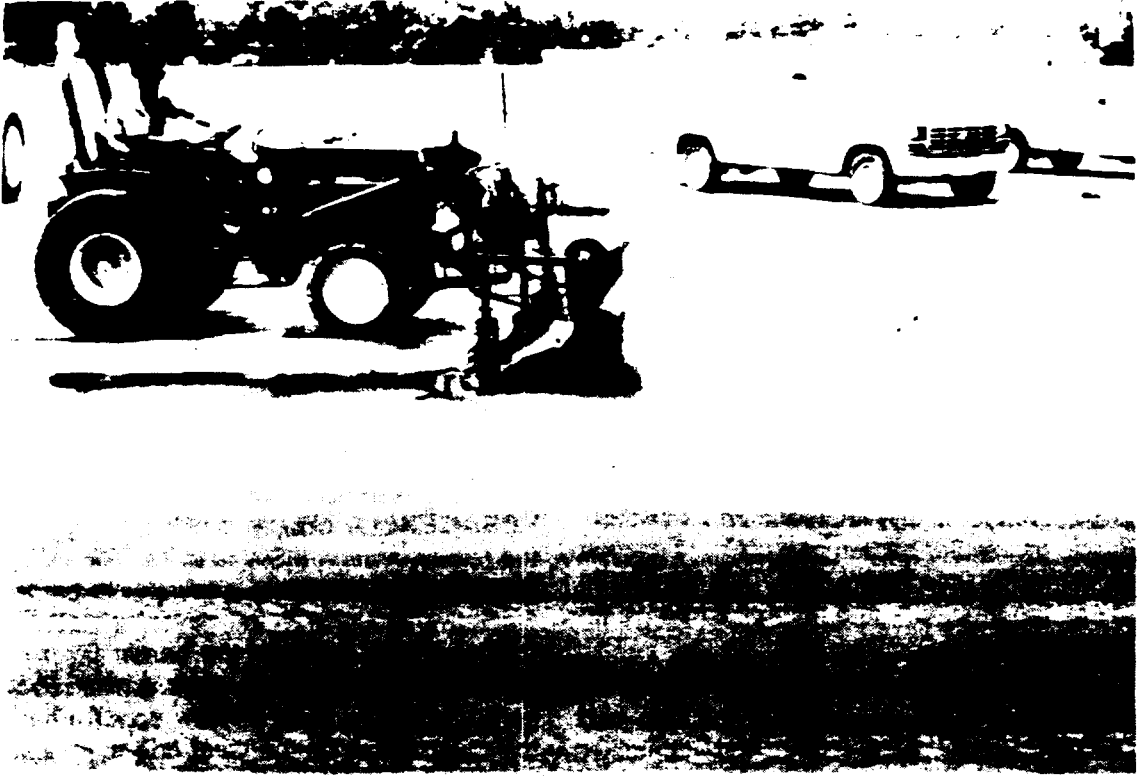

Figure 11-17a. Case 4—Placement of geotextile on asphalt emulsion.



Figure 11-17b. Case 4—Placement of chip seal on geotextile.

the impact of this layer on the agricultural growth placed over the cap. It should be noted, however, that New York requires a liner system beneath all new landfills that actually exceeds RCRA MTG criteria. Thus, the omission of the drainage layer was not for financial reasons.

Contours for the Case 5 cap are shown in Figure 11-18 and reflect the dual slope profile developed in Case 2. The general goals for the MSW cap are low maintenance, minimization of infiltration, and aiding in gas collection/containment. MSW caps commonly cannot be constructed on new landfills in a single stage as can RCRA and CERCLA caps. The staged construction of a MSW cap is required because lined MSW landfills typically are divided into adjacent cells, with each cell built to contain 4 to 6 years of waste. Figure 11-19 shows the profile of the MSW facility with two cells having a common cover.

Facilities have been permitted with more than 10 such cells beneath a common cover. Such facilities eliminate the long-term exposure of the liner system that would result if a single large cell was constructed, and do not lose the airspace between the cells that would occur if individual covers were placed on each cell.

It is necessary to incrementally cap a facility that has multiple adjacent cells to prevent excessive leachate generation. Strategies for incremental cap construction should be reviewed as part of the permitting process. Such strategies should provide for drainage swales spaced at intervals of no more than 6.1 m (20 ft) of vertical grade change over the cap to control surface water runoff.

MSW gas collection systems are commonly either blanket collectors with passive vents or active systems

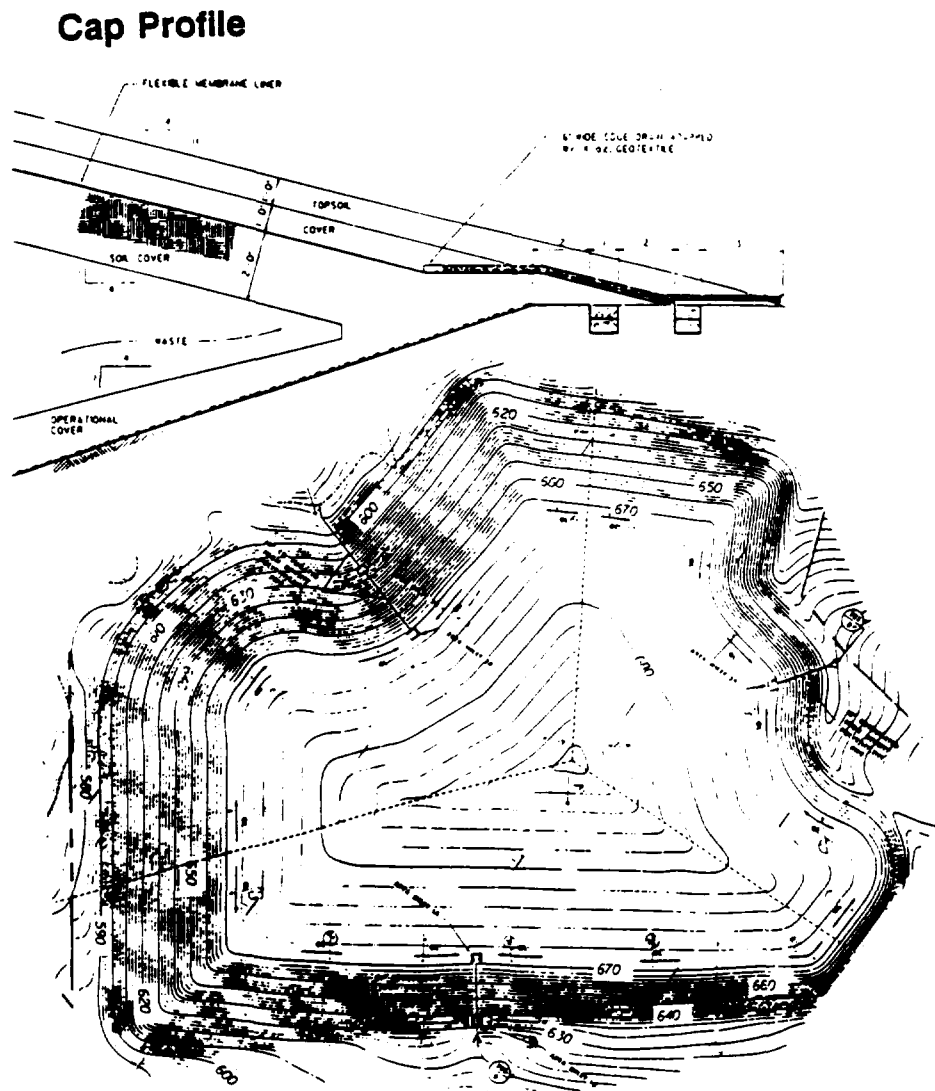

Figure 11-18. Case 5—Cap profile and geometry.

using discrete wells. Figure 11-20 shows the proposed active well array for Case 5. Each well consists of a perforated plastic pipe within a gravel screen. The top of the pipe will penetrate the low hydraulic conductivity barrier, and must be sealed at the soil barrier using a bentonite seal and at the geomembrane barrier using a boot/clamp fixture. As the waste subsides, the gas well pipe will move upward relative to the cap geomembrane. The flexible boot between the pipe and the cap geomembrane must be installed to allow such differential movements. The boots commonly are improperly installed upside down, e.g., they allow movement of the pipe downward relative to the cap geomembrane. This installation, however, must be avoided to prevent damage to the geomembrane seal. This seal not only limits surface water infiltration, but also aids in maintaining the low vacuum required for active gas removal.

The use of a geomembrane in the liner and the cap will eliminate the lateral migration of gas if the geomembranes are intact. Perimeter gas monitoring wells (see Figure 11-21) provide an indication of the condition of the liner and the cap. Such wells are installed at 152- to 305-m (500- to 1,000-ft) spacings around the perimeter of the landfill. Most states now limit gas concentrations in such wells to less than 25 percent of the lower explosive limit of the methane.

## CONCLUSIONS

The five case studies presented in this chapter illustrate the need to closely evaluate the stability of closure systems related to sliding at the interfaces of the layers making up the cap, and alternatives for controlling surface erosion. Additionally, these cases highlight the following permit considerations:

1. The permit should contain requirements for regular monitoring of cap subsidence, criteria for allowable differential cap subsidence, and an agreed-upon method for repair of excessive subsidence.
2. Poorly maintained gas collection systems can allow surface water through the cap. Passive vents should be minimized and protected from damage. Active gas wells will move upward relative to the cap and may damage the cap barrier. Such wells should be inspected regularly and removed when no longer in production.
3. All erosion control systems require maintenance and regular inspection. The limits of both should be established in the permit.

CERCLA caps in particular require careful evaluation to determine which of the RCRA MTG cover components are appropriate for the specific site and waste.

## REFERENCES

1. U.S. EPA. 1989. Technical guidance document: final covers on hazardous waste landfills and surface impoundments. EPA/530-SW-89-047. July.
2. Murphy, W.L. and P.A. Gilbert. 1987. Prediction of landfill cover performance. Unpublished study by COE for EPA-RREL, 1985 through 1987.
3. Richardson, G.N. 1990. Landfill remediation. First U.S. Conference on Municipal Solid Waste, Washington, DC.
4. U.S. EPA. 1988. Geosynthetic design guidance for hazardous waste landfill cells and surface impoundments. EPA/600/52-87/097.

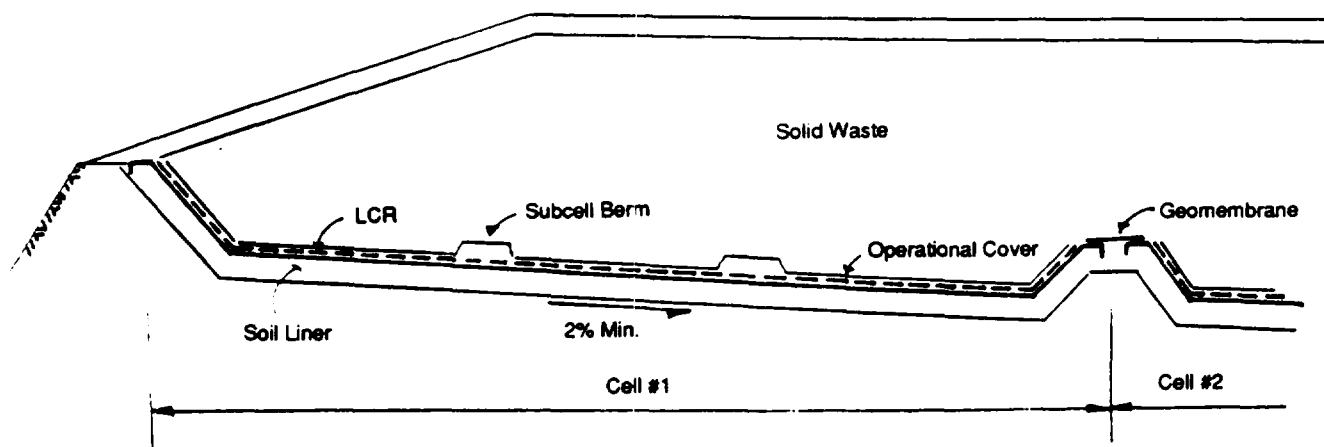

Figure 11-19. Case 5—Profile showing MSW subcells.

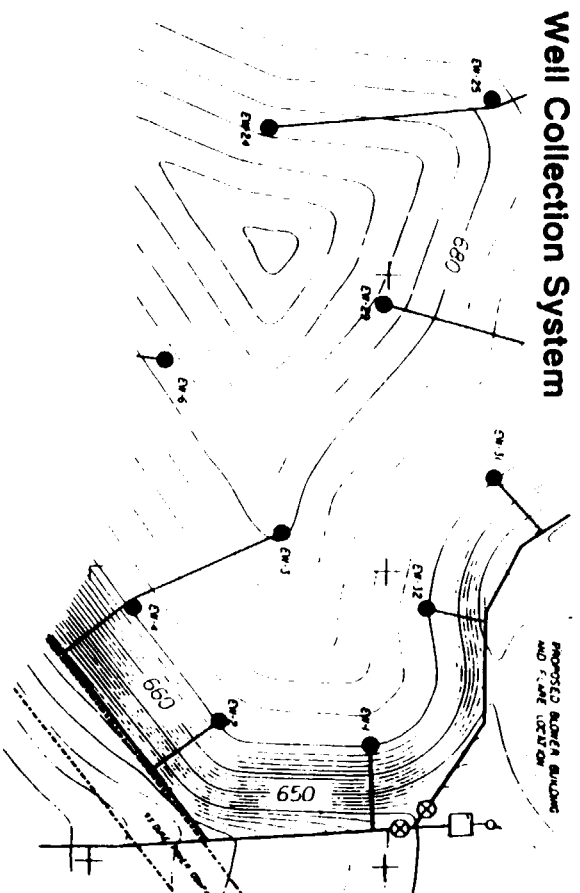

Figure 11-20. Case 5—Gas collector well array.

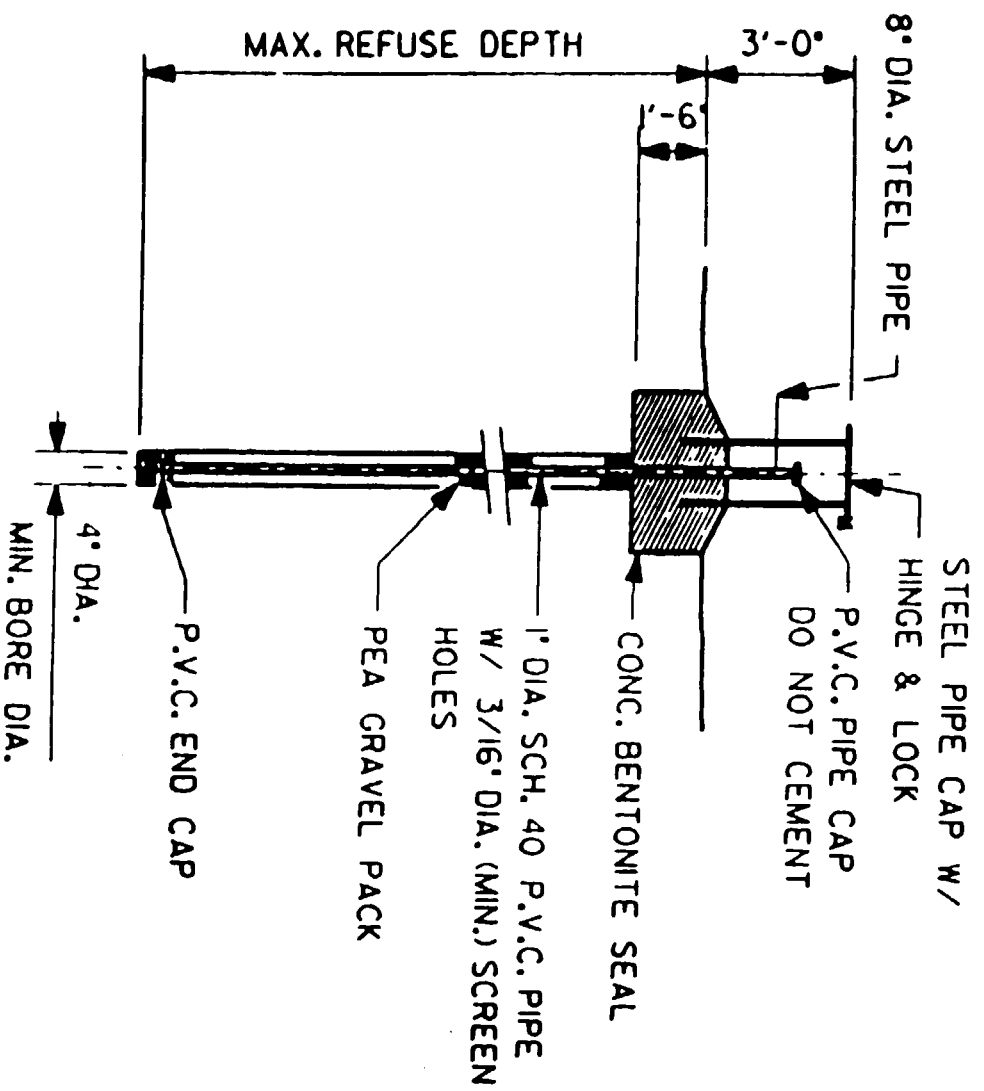

Figure 11-21. Case 5—Perimeter gas monitoring well.

- 
5. Bonaparte, R. et al. 1989. Rates of leakage through landfill liners. IFAI Geosynthetics '89 Conference, San Diego.
  6. Giroud, J.P. et al. 1990. Stability of cover systems on geomembrane covers. *Proceedings*, Fourth International Conference on Geotextiles, The Hague, Netherlands.
  7. U.S. EPA. 1980. Evaluating cover systems for solid and hazardous waste sites. SW-867.
  8. New York - 6 NYCRR Part 360.

#### ADDITIONAL REFERENCES

- U.S. EPA. 1986. Covers for uncontrolled hazardous waste sites. EPA/540/2-85/002.
- U.S. EPA. 1985. Geotextiles for drainage, gas venting, and erosion control at hazardous waste sites. EPA/600/2-86/085.
- U.S. EPA. 1989. Requirements for hazardous waste landfill cells and surface impoundments. Seminar Publication. EPA/600/52-87/097.

## **CHAPTER 12**

### **POSTCLOSURE MONITORING**

#### **INTRODUCTION**

The owner/operator of a facility must give significant consideration during the closure permit process as to the nature and extent of postclosure monitoring that will be required. While regulatory postclosure monitoring time frames range from 30 years for RCRA wastes to 500 years for mixed wastes (10 CFR 61), the actual monitoring period will be influenced by the stability of the waste and cover system. The permit should establish monitoring procedures, acceptance criteria, and remediation methods for the following key parameters:

1. *Ground-water quality* and potentiometric surface should remain within the limits established in permitting.
2. *Leachate quantities* and chemical makeup should remain predictable.
3. *Gas release concentrations* and general air quality must remain within guidelines. Such guidelines will become stricter with time.
4. *Differential subsidence* of the cover must be limited and repaired if allowable limits are exceeded.
5. *Surface erosion* must stay within the 2 ton/year allowable and be repaired on an annual basis.

The key elements in the monitoring program that must be established during permitting are detection methods, allowable limits, and the plan for remediation when limits are exceeded.

#### **GROUND-WATER MONITORING**

Key monitoring variables in a comprehensive ground-water monitoring program include both changes in the potentiometric surface that could bring the landfill liner system in contact with the ground water and the chemical quality of the ground water that is an indicator of leachate release. In RCRA facilities, both the potentiometric and background water quality will be established during permitting of the landfill prior to placement of the waste. For CERCLA facilities, such information should be established during the closure permit process.

A ground-water well network must be established that both tracks changes in the ground-water potentiometric

surface and detects leakage from the facility. In both RCRA and CERCLA facilities, the background quality of the ground water must be documented prior to closure.

Individual monitoring wells must be designed to reflect both the anticipated contaminant and the site-specific stratigraphy. Figure 12-1 shows a typical well configuration. The well casing will commonly be PVC for inorganic contaminants and stainless steel for organic contaminants. While monitoring wells have become very standardized, it is important to specify locking well caps that prevent tampering of the well, well seals that restrict surface water flow into the well, and solvent free well pipe connections that do not contaminate the well.

In CERCLA sites, great care must be taken during the placement of monitoring wells and during any soil borings to avoid penetrating an aquiclude (low hydraulic conductivity soil layer) that may lie underneath contaminated ground water. Figure 12-2 shows such a potential stratigraphy. When placing monitoring wells through an aquiclude, a casing must first be installed from the ground to the aquiclude. A grout seal is then established to hydraulically isolate this casing from the aquiclude, and the monitoring well is drilled to the lower aquifer within the casing. In this manner, the contamination from the upper aquifer will not contaminate the lower aquifer.

Ground water should be sampled at a frequency defined by the level of anticipated contamination and the site conditions. Generally, it is useful to have monthly ground-water background data prior to permitting operation or closure of a facility. Post-operation sampling frequency then can be decreased to quarterly monitoring, which should be maintained unless the consistency of measurements and operation justify sampling less frequently. Postclosure monitoring frequencies commonly range from quarterly for lined RCRA facilities to annually for common MSW landfills.

#### **LEACHATE MONITORING**

Both the quantity and composition of leachate generated within a RCRA facility provide significant information on the performance of the closure system. If the closure system is properly designed and installed, the rate of leachate generation in the primary collector will decrease with time. If the closure is not complete, then the rate of

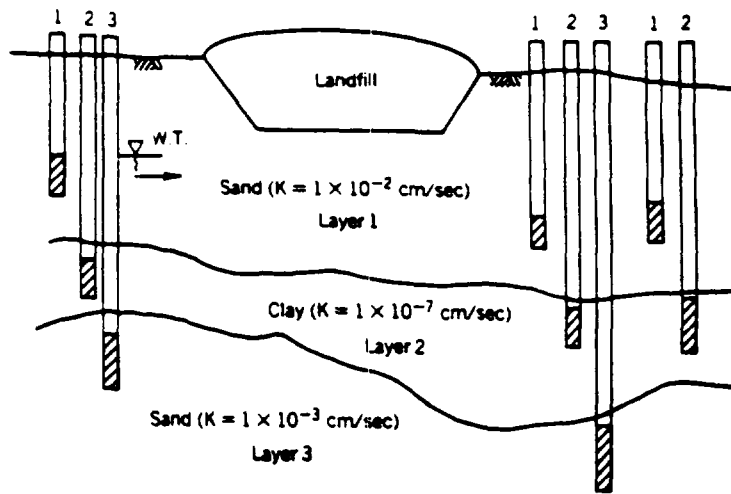

Figure 12-1. Monitoring well configuration.

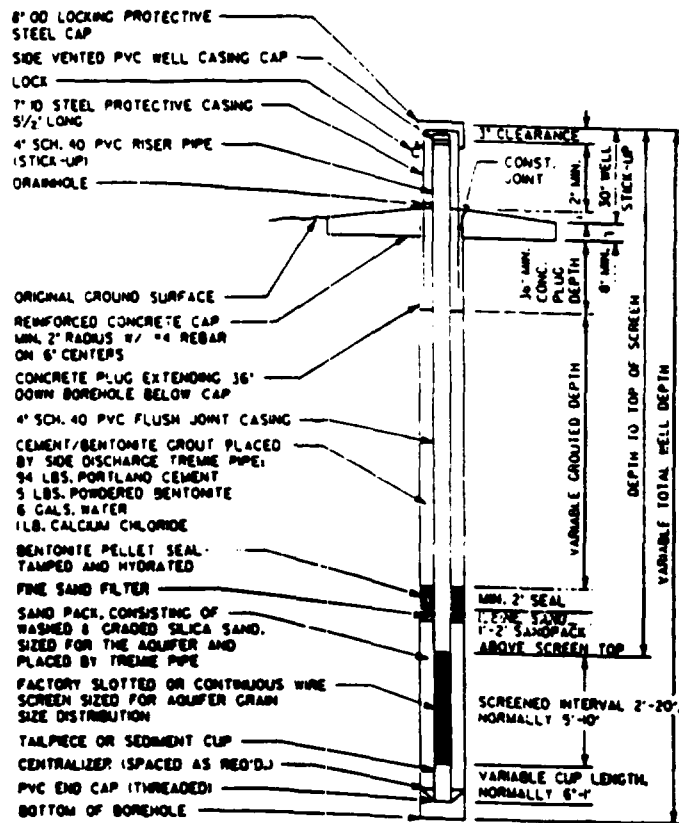

Figure 12-2. Monitoring Interbedded aquifer.

## Impact of Biological Growth

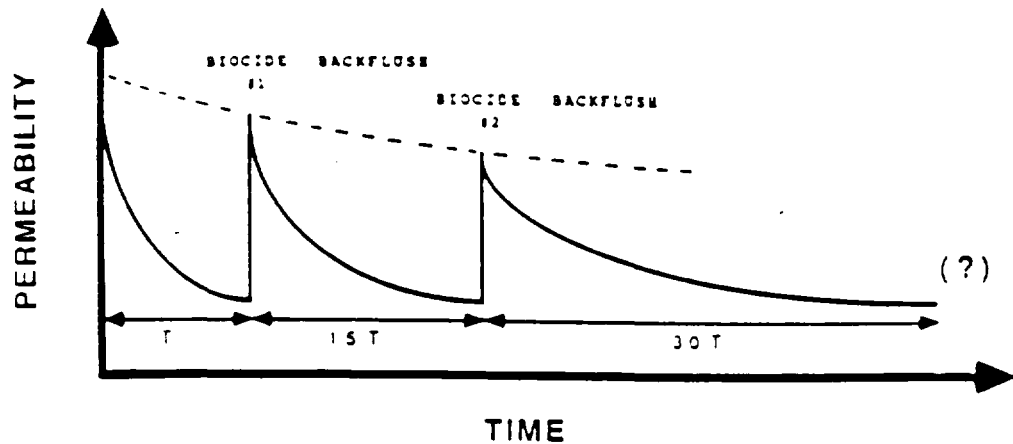

Figure 12-3. Impact of biological growth on filters.

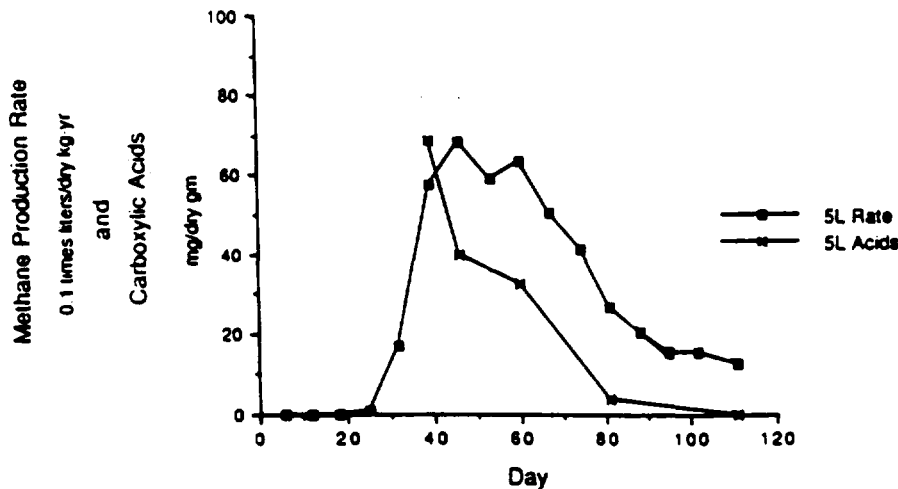

Figure 12-4. Gas generation versus time.

leachate generation in the primary collector may reflect precipitation trends. Therefore, the integrity of the closure can be verified by evaluating leachate quantity records. A sudden increase in the quantity of leachate generated will clearly indicate failure of the closure. Unfortunately, many CERCLA facilities will lack a liner and primary collector system.

The concentration of contaminants in a facility's leachate will increase with time until an equilibrium condition is established. A sudden reduction in this level of contaminants is a good indication that the cover has been breached, allowing a slug of surface water to enter the waste and dilute the leachate. Biological growth, however, can also have a significant impact on the monitoring system over the long term. Figure 12-3 shows the impact of biological growth in municipal solid waste

(MSW) leachate on the permeability of a geotextile filter commonly used in collector systems (1). The time,  $T$ , for significant reduction in permeability may be as short as 6 weeks. Thus, a long-term decrease in the amount of leachate generated may indicate biological clogging of the collector, which may prevent detecting failure of the closure. Such biological clogging occurred recently in a MSW landfill in Delaware. A significant head of perched leachate was discovered within the waste while the quantity of leachate generated was actually decreasing. This clogging required excavation of the waste and replacement of the primary collector system.

### GAS GENERATION

Gas generation within a waste containment system must be monitored both to ensure that such gas does not

Table 12-1. Threshold Limits of Air Contamination

Threshold Limit Values of Selected Air Contaminants*	
Contaminant	TLV
Dust	1 mg/m <sup>3</sup>
Carbon monoxide	50 ppm
Asbestos	0.2 to 2 fibers/cm <sup>3</sup> (depending on asbestos type)
Benzene	10 ppm
Coal dust	2 mg/m <sup>3</sup>
Cotton dust	0.2 mg/m <sup>3</sup>
Grain dust	4 mg/m <sup>3</sup>
Hydrogen sulfide	10 ppm
Nuisance particulates	10 mg/m <sup>3</sup>
Phenol	5 ppm
Vinyl chloride	5 ppm
Wood dust	
Hard wood	1 mg/m <sup>3</sup>
Soft wood	5 mg/m <sup>3</sup>

\*Values of TLV obtained from the American Conference of Governmental Industrial Hygienists (1987).

migrate off site and to indicate closure performance. The rates of gas generation vary from more than 900 liters/kg waste/year in MSW wastes (2) to insignificant rates in RCRA commercial landfills. The rate of gas generation in future MSW landfills is anticipated to decrease as these landfills are constructed with liners and leachate collection systems. The addition of a geomembrane in the cover will significantly decrease the amount of surface water infiltration and also lead to lower gas generation rates.

When geomembranes are used in a cover, very little gas can escape vertically. Therefore, in an unlined facility, such as a typical CERCLA closure, escaping gas will move to the perimeter of the cover. Simple gas monitoring wells (described in Chapter 11, Case 5) must be installed around the perimeter of the cover to detect laterally moving gas. The level of gas at such wells must remain below 25 percent of the lower explosive limit (LEL). The level of gas production can vary significantly with the weather; therefore, the monitoring frequency should be increased when the surrounding ground is saturated or frozen.

Gas odors detected above a closure system that includes a geomembrane indicate that the geomembrane has a significant penetration. A regular survey of gas levels on the surface of the closure is a good method of verifying the integrity of the cap barrier.

As detailed in Chapter 11, gas removal systems must be designed with a minimal number of penetrations through the cover system. Each vent is a potential major leak. For passive systems, a maximum of one vent per acre should be included initially. If monitoring of these vents reveals excessively high gas concentrations, then additional wells can be installed. In active systems, gas wells must

be removed when they are no longer productive to prevent damage to the cover.

As with leachate quantities, the rate of gas generation should also decrease with time if the cover system is functioning properly such that moisture does not reach the waste. Figure 12-4 shows the result of laboratory column gas generation tests (3). In the figure, methane production rate and the level of carboxylic acids in the leachate decrease with time. A properly functioning cover will ensure that the leachate will remain acidic and that gas production will be low.

## SUBSIDENCE MONITORING

Chapter 11 discusses the ability of the cap barrier components to tolerate differential settlements due to w subsidence. In Case 1, differential settlements as large as 0.5 m in 6 m (1.8 ft in 20 ft) were tolerated by composite barriers. Thus, the level of differential settlements of interest during postclosure monitoring can be quite large. Such levels can commonly be found by walking the cover after a rain storm and looking for major puddles or ponding. Subsidence depressions also can be found through an annual survey of the cover using either conventional or aerial survey methods.

Subsidence depressions must be remediated below the level of the barrier system to avoid long-term acceleration of the subsidence due to a "roof ponding" mechanism. Roof ponding refers to the common failure in flat roof systems where ponding water causes the roof rafters to deflect, thus allowing more water to pond, causing more deflection, and so on. This mechanism continues until the roof collapses. Remediation requires removing the cover system in the region of subsidence and backfilling the depression with lightweight fills. This fill may either be

more waste or commercial lightweight aggregates. The full cover profile must then be rebuilt over the new fill.

### **SURFACE EROSION**

All cover systems will erode and require long-term maintenance. Cover systems with moderate slopes and an agricultural cover will typically require annual maintenance of 0.5 percent of their surface area; this percentage increases with slope. Thus, all covers that use agricultural covers require an annual inspection and repair program. Such repair may include cleaning out surface water swales, replacing cover soil, and reestablishing vegetation. Areas of the cover requiring repeated repair may benefit from hardening or the use of geosynthetic erosion control blankets. Covers that use hardened erosion control systems should also be inspected annually, though annual maintenance should not be required.

The annual inspection should verify that the agricultural cover is being mowed at least annually to prevent the growth of deep-rooted volunteer vegetation. In arid regions of the country or during droughts, full RCRA covers may not be able to maintain vegetation unless the plants are very drought resistant. This loss of vegetation is due to moisture loss in the root zone of the cover soil, resulting from the underlying drainage system.

### **AIR QUALITY MONITORING**

Air emissions from waste storage facilities will come under increasing scrutiny in the next decade. Monitoring

techniques will be similar to those used at industrial facilities and include passive samples obtained using collection media, grab samples obtained in evacuated sample vessels, and active pump and filter samples. The most common air contaminants coming from the waste disposal cell obviously are waste dependent; for MSW wastes, these are methane, vinyl chloride, and benzene. Table 12-1 presents typical allowable limits of selected air contaminants. Such limits are currently undergoing extensive review; significantly lower allowable levels are anticipated for future operations.

The geomembrane component of the MTG cover composite barrier system controls air emissions significantly. In fact, the presence of emissions indicates that the geomembrane cover has failed and needs to be repaired immediately.

### **REFERENCES**

1. Unpublished research at Geosynthetic Research Institute, personal communication with R.M. Koerner.
2. Walsh, J.L. 1988. Handbook on biogas utilization. Georgia Tech Research. February.
3. Barlaz, M.A. et al. 1989. Bacterial population development and chemical characteristics of refuse decomposition in a simulated sanitary landfill. *Applied and Environmental Microbiology*. January.

---

**APPENDIX A**  
**STABILITY AND TENSION CONSIDERATIONS REGARDING COVER SOILS ON**  
**GEOMEMBRANE-LINED SLOPES**

**Stability and Tension Considerations Regarding Cover Soils on  
Geomembrane Lined Slopes**

by

**Robert M. Koerner and Bao-Lin Hwu  
Geosynthetic Research Institute  
Drexel University  
Philadelphia, Pennsylvania 19104**

Abstract

The occurrence of cover soil instability in the form of sliding on geomembranes is far too frequent. Additionally, there have been cases of wide width tension failures of the underlying geomembranes when the friction created by the cover soil becomes excessive. While there are procedures available in the literature regarding rational design of those topics, it is felt that a unified step-by-step perspective might be worthwhile. It is in this light that this paper is written. Included are four separate, but closely interrelated, design models. They are the following:

- cover soil stability on side slopes when placed above a geomembrane,
- cover soil reinforcement provided by either geogrids or geotextiles,
- wide width tension mobilized in the geomembrane caused by the interface friction of the soils placed above and below the geomembrane, and
- circumferential tension mobilized in the geomembrane by subsidence of the subgrade material beneath the geomembrane.

Each of these designs are developed in detail and a numeric problem is framed to illustrate the design procedure. Emphasized throughout the paper is the need for realistic laboratory test values of interface friction, in-plane tension and out-of-plane tension of the geomembranes. By having realistic experimental values of allowable strength they can be compared to the required, or design, strength for calculation of the resulting factor-of-safety against instability or failure.

## Stability and Tension Considerations Regarding Cover Soils on Geomembrane Lined Slopes

### Introduction

Geomembrane lined soil slopes are common in many areas of civil engineering construction but nowhere are they more prevalent than in the environmental related field of the containment of solid waste. Cover soils on geomembranes placed above the waste as in landfill caps and closures as well as lined side slopes beneath the waste are commonplace as the sketches of Figure 1 indicate. The variations of soil types beneath the geomembrane as well as above the geomembrane are enormous. They range from moist clays in the form of composite liners to drainage sands and gravels of very high permeability. The likelihood of having other geosynthetic materials adjacent to the geomembranes (like geotextiles, geonets and drainage geocomposites) presents another set of variables to be considered. Lastly, the existence of many different geomembrane types, having different thicknesses, strengths, elongations and surface characteristics leads to the necessity of performing a rational design on such systems. Clearly, the development of design models to evaluate the stability of the overlying materials as well as the tensile stresses that may be induced in the underlying geomembranes should always be performed. Fortunately, both the stability of the overlying soil materials and the reduction of tensile stress in the geomembrane can be accommodated by reinforcing the cover soil with either geogrids or geotextiles. This is becoming known as veneer stability reinforcement and is necessitated due to a number of cover soil stability, or sloughing, failures, some of which are shown in the photographs of Figure 2.

This paper presents several design models and their development into design equations for cover soil stability (both without and then with reinforcement) and for the induced tensile stresses that are mobilized in the underlying geomembrane. The approach taken in this paper will utilize a single geomembrane, but it should be recognized that double liners are frequently used beneath solid and liquid waste. Design considerations into the secondary liner, however, can be handled by reasonable extensions of the material to be presented.

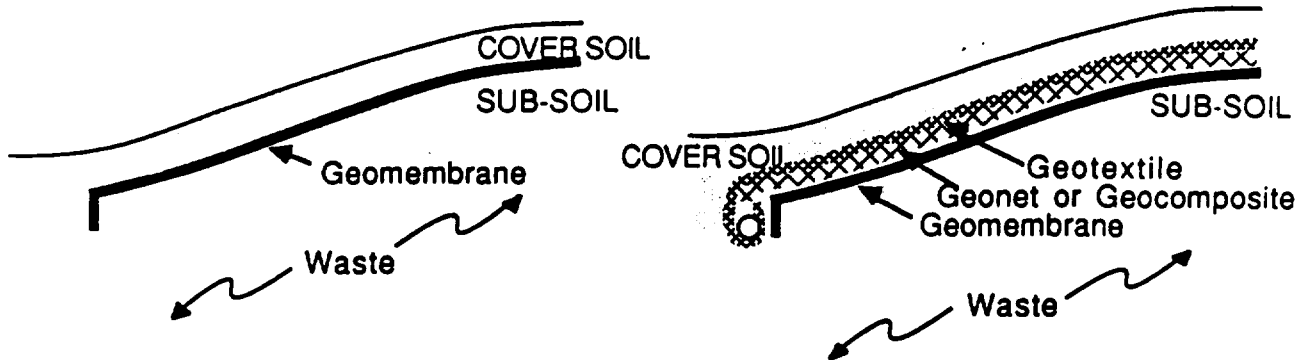

(a) Landfill Cover with Soil Above Geomembrane

(b) Landfill Cover with Drainage Geosynthetic Above Geomembrane

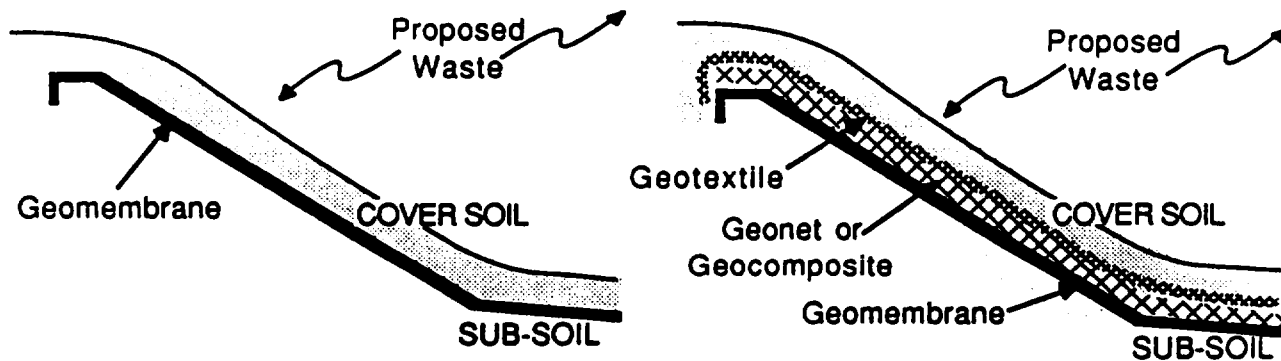

(c) Landfill Liner with Soil Above Geomembrane

(d) Landfill Liner with Drainage Geosynthetic Above Geomembrane

Figure 1 - Various Solid Waste Geomembrane Covers and Liners Involving Natural Soils and/or Drainage Geosynthetics



Figure 2 - Cases of Cover Soil Instability for Case 1(a) (upper photo) and for Case 1(c) (lower photo) as shown in Figure 1

## Interface Friction Considerations

It will be seen that at the heart of the design equations to be developed in this paper are interface friction values between the geomembrane and the overlying soils or drainage geosynthetics and also against the underlying soils or drainage geosynthetics. These values are obtained by direct shear evaluation in simulated laboratory tests. Unfortunately, many aspects of the direct shear test have not yet been standardized (although ASTM has a Task Group working on a draft Standard), and many important details must be left to the design engineer and testing organization. For example, the following items need to be carefully considered.

- minimum or maximum size of shear box
- aspect dimensions of the test specimen
- type of fixity of the geomembrane to the shear box and to a substrate
- moisture conditions during normal stress application
- type of liquid to use during sample preparation and testing
- method and duration of normal stress application
- strain controlled or stress controlled shear application
- rate of shear application
- moisture conditions and drainage during shear application
- duration of test
- number of replicate tests at different normal stresses
- linearity of resulting failure envelope

Thus the use of reported values in the published literature can only be used with considerable caution and, at best, for preliminary design.<sup>(1-3)</sup> For final design and/or permitting, the site specific conditions and the proposed materials must be used in the tests so as to obtain realistic values of the shear strength parameters adhesion ( $c_a$ ) and interface friction ( $\delta$ ). Additionally, tests should also be performed on the soil by itself so as to obtain a reference value for comparison to the inclusion of the geomembrane. Calculation of the adhesion efficiency on soil cohesion and a frictional efficiency to that of the soil by itself are meaningful in assessing the numeric results of the designs to follow, i.e.

$$E_c = c_a/c (100) \tag{1}$$

$$E_\phi = \tan \delta / \tan \phi (100) \tag{2}$$

where

- $E_c$  = efficiency on cohesion
- $c_a$  = adhesion of soil-to-geomembrane
- $c$  = cohesion of soil-to-soil
- $E_\phi$  = efficiency on friction
- $\delta$  = friction angle of soil-to-geomembrane
- $\phi$  = friction angle of soil-to-soil

### Past Investigations and Analyses

The isolation of free body diagrams depicting the site specific situation to be analyzed is certainly not new. It is a direct extension of geotechnical engineering of soil stability and is reasonably straightforward since the failure plane against the geomembrane is clearly defined. Thus a computer search is generally not necessary to locate the minimum factor-of-safety stability value. Also it should be recognized that the failure surface is usually linear, rather than circular, log spiral, or other complicated geometric shape in that it follows the surface of the geomembrane itself.

A procedure which nicely accommodates a clearly defined straight line slip surface has been developed by the U.S. Army Corps of Engineers.<sup>(4)</sup> Their wedge analysis procedures form the essence of the developments to follow. The graphic procedures are outlined in Reference #4 but are developed in this paper into design equations in a more rigorous manner. Also to be mentioned is the work of Giroud and Beech<sup>(5)</sup> and Giroud, et al.<sup>(6)</sup> in providing excellent insight into several aspects of the design.

In the first referenced paper, by Giroud and Beech<sup>(5)</sup>, a two-part wedge method is utilized to arrive at a similar equation as ours except without an adhesion term. Also, the treatment at the top of the slope is slightly different. Their work will be referenced in the second problem of this set of four examples and a comparison of results will be made. In the second referenced paper, by Giroud, et al.<sup>(9)</sup>, a large overburden stress necessitated the use of arching theory to recognize that a limiting value will occur when the geomembrane is located beneath deep fills. This is not the case with the shallow overburden stresses imposed by cover soils placed on geomembranes that are the focus of this paper. In the fourth example to be presented we will use the full thickness of the overburden times its unit weight. Additionally, we will not use a deformation/strain reduction value in the interest of being conservative. The reference cited by Giroud, et al.<sup>(9)</sup> should be used in this regard.

### Model #1: Stability of Cover Soil Above a Geomembrane

Consider a cover soil (usually a permeable soil like gravel, sand or silt) placed directly on a geomembrane at a slope angle of " $\omega$ ". Two discrete zones can be visualized as seen in Figure 3. Here one sees a small passive wedge resisting a long, thin active wedge extending the length of the slope. It is assumed that the cover soil is a uniform thickness and constant unit weight. At the top of the slope, or at an intermediate berm, a tension crack in the cover soil is considered to occur thereby breaking communication with additional cover soil at higher elevations.

Resisting the tendency for the cover soil to slide is the adhesion and/or interface friction of the cover soil to the specific type of underlying geomembrane. The values of " $c_a$ " and " $\delta$ " must be obtained from a simulated laboratory direct shear test as described earlier. Note that the passive wedge is assumed to move on the underlying cover soil so that the shear parameters " $c$ " and " $\phi$ ", which come from soil-to-soil friction tests, will also be required.

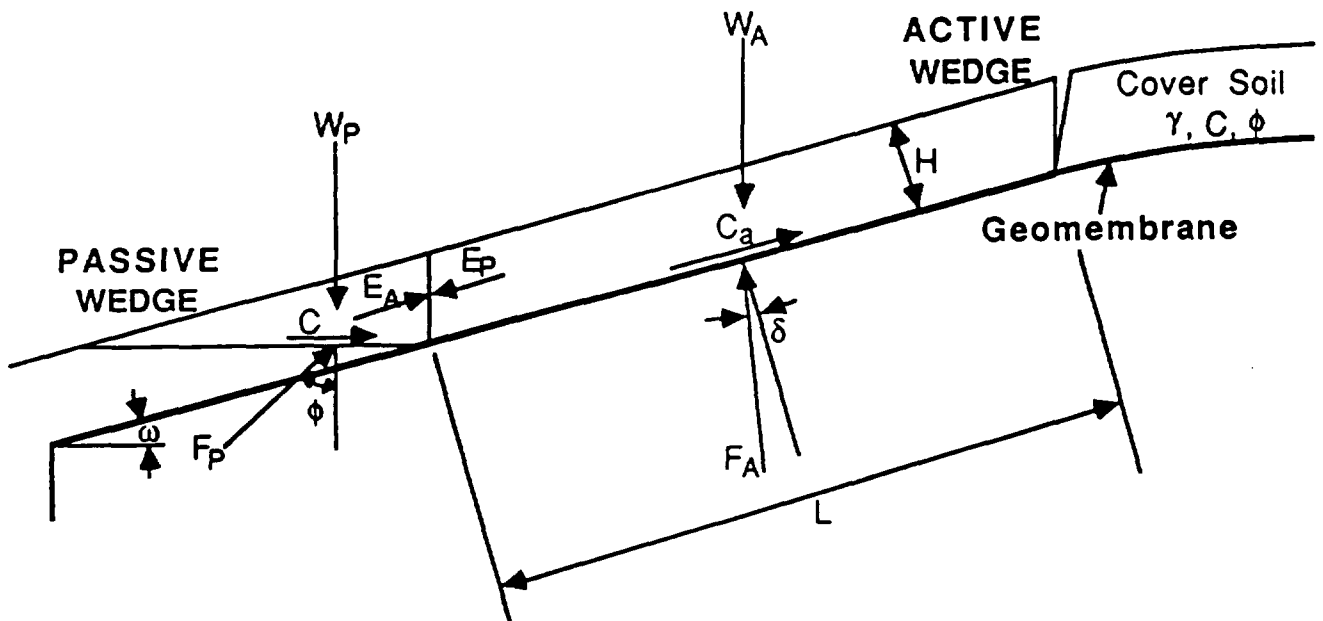

Figure 3 - Cross Section of Cover Soil on a Geomembrane Illustrating the Various Forces Involved on the Active and Passive Wedges

By taking free bodies of the passive and active wedges with the appropriate forces being applied, the following formulation for the stability factor-of-safety results, see Equation 3. Note that the equation is not an explicit solution for the factor-of-safety (FS), and must be solved indirectly. The complete development of the equation is given in Appendix "A".

$$\begin{aligned}
 (FS)^2 [0.5 \gamma LH \sin^2(2\omega)] - (FS) [\gamma LH \cos^2 \omega \tan \delta \sin(2\omega) + c_a L \cos \omega \sin(2\omega) \\
 + \gamma LH \sin^2 \omega \tan \phi \sin(2\omega) + 2cH \cos \omega + \gamma H^2 \tan \phi] \\
 + [(\gamma LH \cos \omega \tan \delta + c_a L) (\tan \phi \sin \omega \sin(2\omega))] = 0
 \end{aligned} \tag{3}$$

Using  $ax^2 + bx + c = 0$ , where

$$\begin{aligned}
 a &= 0.5 \gamma LH \sin^2 2\omega \\
 b &= -[\gamma LH \cos^2 \omega \tan \delta \sin(2\omega) + c_a L \cos \omega \sin(2\omega) \\
 &\quad + \gamma LH \sin^2 \omega \tan \phi \sin(2\omega) + 2cH \cos \omega + \gamma H^2 \tan \phi] \\
 c &= (\gamma LH \cos \omega \tan \delta + c_a L) (\tan \phi \sin \omega \sin(2\omega))
 \end{aligned}$$

the resulting factor-of-safety is as follows:

$$FS = \frac{-b \pm \sqrt{b^2 - 4ac}}{2a} \tag{4}$$

When the calculated factor-of-safety value falls below 1.0, a stability failure of the cover soil sliding on the geomembrane is to be anticipated. However, it should be recognized that seepage forces, seismic forces and construction placement forces have not been considered in this analysis and all of these phenomena tend to lower the factor-of-safety. Thus a value of greater than 1.0 should be targeted as being the minimum acceptable factor-of-safety. An example problem illustrating the use of the above equations follows:

**Example Problem:** Given a soil cover soil slope of  $\omega = 18.4^\circ$  (i.e., 3 to 1),

$L = 300$  ft.,  $H = 3.0$  ft.,  $\gamma = 120$  lb/ft<sup>3</sup>,  $c = 300$  lb/ft<sup>2</sup>,  $c_a = 0$ ,  $\phi = 32^\circ$ ,  $\delta = 14^\circ$ ,

determine the resulting factor-of-safety

**Solution:**

$$\begin{aligned}
 a &= 0.5 (120) (300) (3) \sin^2 (36.8^\circ) \\
 &= 19,400 \text{ lb/ft} \\
 b &= -[(120) (300) (3) \cos^2 (18.4^\circ) \tan (14^\circ) \sin (36.8^\circ) \\
 &\quad + 0 + (120) (300) (3) \sin^2 (18.4^\circ) \tan (32^\circ) \sin (36.8^\circ) \\
 &\quad + 2 (300) (3) \cos (18.4^\circ) + 120 (9) \tan (32^\circ)]
 \end{aligned}$$

$$= - [14523 + 0 + 4028 + 1708 + 675]$$

$$= - 20,934 \text{ lb/ft}$$

$$c = [(120) (300) (3) \cos (18.4^\circ) \tan (14^\circ) + 0]$$

$$[\tan (32^\circ) \sin (18.4^\circ) \sin (36.8^\circ)]$$

$$= [25500] [0.118]$$

$$= 3019 \text{ lb/ft}$$

$$FS = \frac{20,934 + \sqrt{(-20934)^2 - 4(19400)(3019)}}{38,800}$$

FS = 0.91, which signifies that a stability failure will occur

### Model #2: Reinforcement of Cover Soil on a Geomembrane

Once the cover soil factor-of-safety becomes unacceptably low for the site specific conditions (as illustrated in the previous problem), a possible solution to the situation is to add a layer of geogrid or geotextile reinforcement as shown in Figure 4. In the case of landfill covers, the tensile stresses that are mobilized in the reinforcement are carried over the crown to (generally) an equal and opposite reaction on the opposing slope. Alternatively, these stresses can be carried in friction via an anchorage mode of resistance as would occur in an intermediate berm situation. For a landfill liner, the stresses in the reinforcement are generally carried to an individual anchor trench extending behind the geomembrane anchor trench. If the reinforcement is a geogrid it is placed within the cover soil so that soil can strike-through the apertures and the maximum amount of anchorage against the transverse ribs can be mobilized. When using geotextiles, they can be placed directly on the geomembrane, or embedded within the cover soil so as to mobilize friction in both surfaces.

The tensile stress of the reinforcement layer per unit width is calculated by setting "E<sub>A</sub>" equal to "E<sub>p</sub>" in Figure 3 and solving for the unbalanced force "T" in Figure 4 which is required for a factor-of-safety equal to one. This value of T becomes T<sub>reqd</sub> which is given in Equation 5. The complete development is available in Appendix "B".

$$T_{reqd} = \frac{\gamma LH \sin(\omega - \delta)}{\cos \delta} - c_a L - \frac{\cos \phi \left[ \frac{cH}{\sin \omega} + \frac{\gamma H^2}{\sin 2\omega} \tan \phi \right]}{\cos(\phi + \omega)} \quad (5)$$

This value is now compared to the allowable wide width tensile strength of the particular geogrid or geotextile under consideration, i.e.,

$$FS = T_{allow} / T_{reqd} \quad (6)$$

Note that the value of "T<sub>allow</sub>" must include such considerations as installation damage, creep and long-term degradation from chemical or biological interactions. If the value is obtained from a test such as ASTM D-4595, the wide width strip tensile test, the use of partial factors-of-safety is recommended to accommodate the above items.<sup>(7)</sup> An example problem using

Equations 5 and 6 follows:

**Example Problem:** Continue the previous problem of cover soil instability where a geogrid with allowable wide width tensile strength of 4000 lb/ft is being considered (i.e., the value includes the above mentioned partial factors-of-safety). What is the resulting overall factor-of-safety? The parameters are  $\omega = 18.4^\circ$ ,  $L = 300$  ft.,  $H = 3.0$  ft.,

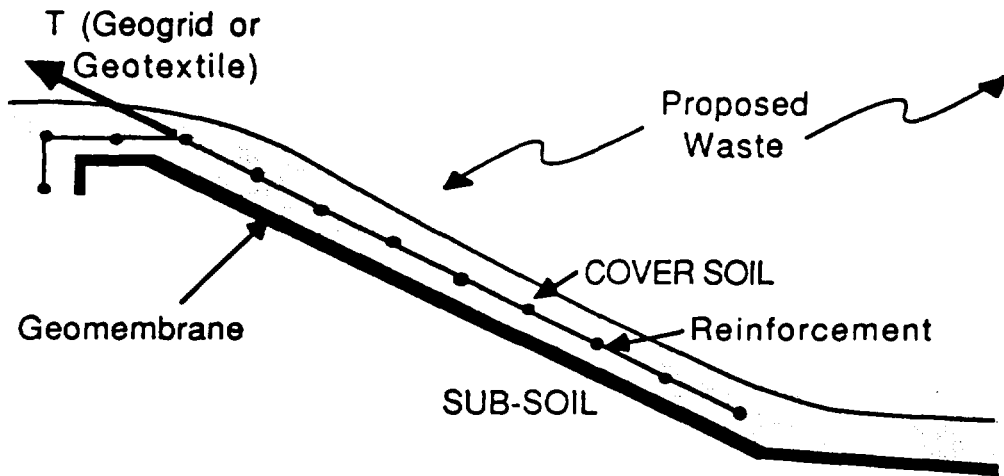
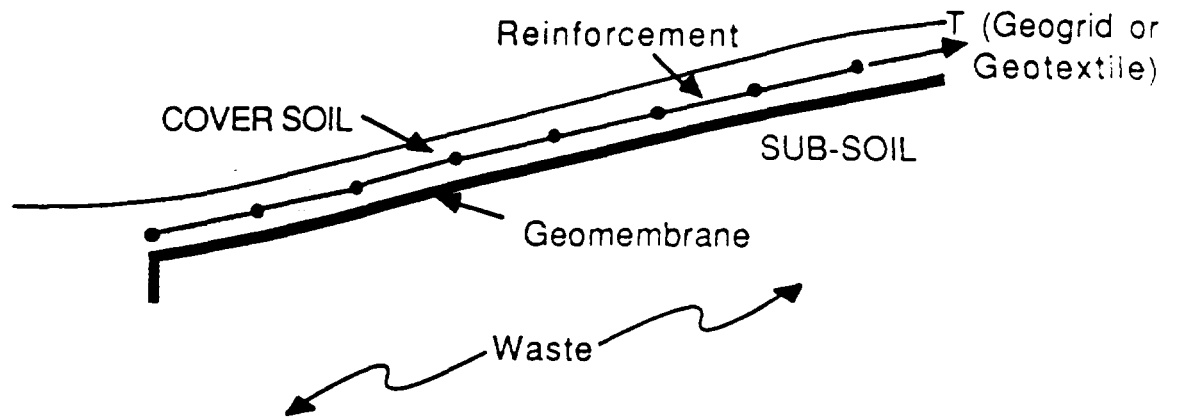

Figure .4 - Geogrid or Geotextile Reinforcement of a Cover Soil Above Waste and of a Cover Soil on a Geomembrane Beneath Waste

$$\gamma = 120 \text{ lb/ft}^3, c = 300 \text{ lb/ft}^2, c_a = 0, \phi = 32^\circ, \delta = 14^\circ.$$

Solution:

$$T_{\text{reqd}} = \frac{(120)(300)(3) \sin(4.4^\circ)}{\cos(14^\circ)} - 0$$

$$- \frac{\cos(32^\circ) \left[ \frac{(300)(3)}{\sin(18.4^\circ)} + \frac{(120)(9)}{\sin(36.8^\circ)} \tan(32^\circ) \right]}{\cos(50.4^\circ)}$$

$$= 8539 - 0 - 5292$$

$$T_{\text{reqd}} = 3247 \text{ lb/ft}$$

$$FS = T_{\text{allow}} / T_{\text{reqd}}$$

$$= \frac{4000}{3247}$$

$$FS = 1.23, \text{ which is marginally acceptable and a stronger reinforcement or a double layer should be considered.}$$

Note: Using the formulation developed by Giroud and Beech<sup>(5)</sup> with the soil cohesion equal to zero results in a  $T_{\text{reqd}} = 6890 \text{ lb/ft}$ , while the above formulation adjusted for a zero cohesion results in  $T_{\text{reqd}} = 7040 \text{ lb/ft}$ . Thus the methods appear to be comparable to one another.

Model #3: Geomembrane Tension Stresses Due to Unbalanced Friction Forces

The shear stresses from the cover soil above the liner act downward on the underlying geomembrane and in so doing mobilize upward shear stresses beneath the geomembrane from the underlying soil. The situation is shown in the sketch of Figure 5.

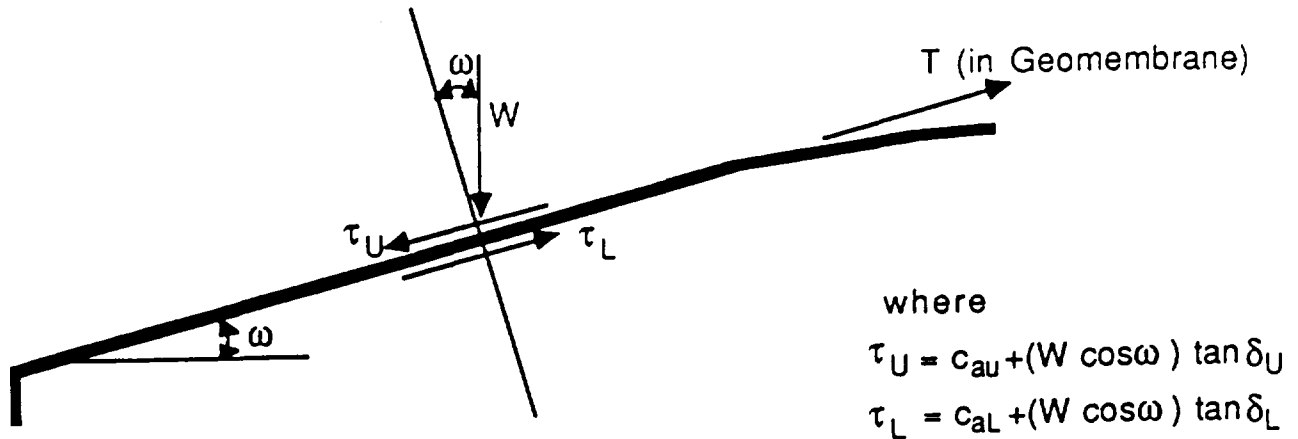

Figure 5 - Shear and Tensile Stresses Acting on a Covered Geomembrane

Here three different scenarios can be envisioned:

- If  $\tau_U = \tau_L$ , the geomembrane goes into a state of pure shear which should not be of great concern for most types of geomembranes
- If  $\tau_U < \tau_L$ , the geomembrane goes into a state of pure shear up to a magnitude of  $\tau_U$  and the balance of  $\tau_L - \tau_U$  is simply not mobilized
- If  $\tau_U > \tau_L$ , the geomembrane goes into a state of pure shear equal to  $\tau_L$  and the balance of  $\tau_U - \tau_L$  must be carried by the geomembrane in tension.

This latter case is the focus of this part of the design process. The situation generally occurs when a material with high interface friction (like sand or gravel) is placed above the geomembrane and a material with low interface friction (like high moisture content clay) is placed beneath the geomembrane. The essential equation for the design is as follows where "T" is in units of force per unit width, i.e., T/W. The complete derivation follows in Appendix "C".

$$T/W = [(c_{aU} - c_{aL}) + \gamma H \cos \omega (\tan \delta_U - \tan \delta_L)] L \quad (7)$$

The resulting value of force per unit width "T/W" is then compared to the allowable strength of the geomembrane which is shown schematically for different geomembranes in Figure 6. The target values are  $T_{break}$  for scrim reinforced geomembranes,  $T_{yield}$  for semi-crystalline geomembranes and  $T_{allow}$  (at a certain value of strain) for nonreinforced flexible geomembranes. Note that these curves should be obtained from a wide width tensile test which is currently under development in Committee D-35 on Geosynthetics in ASTM.<sup>(8)</sup>

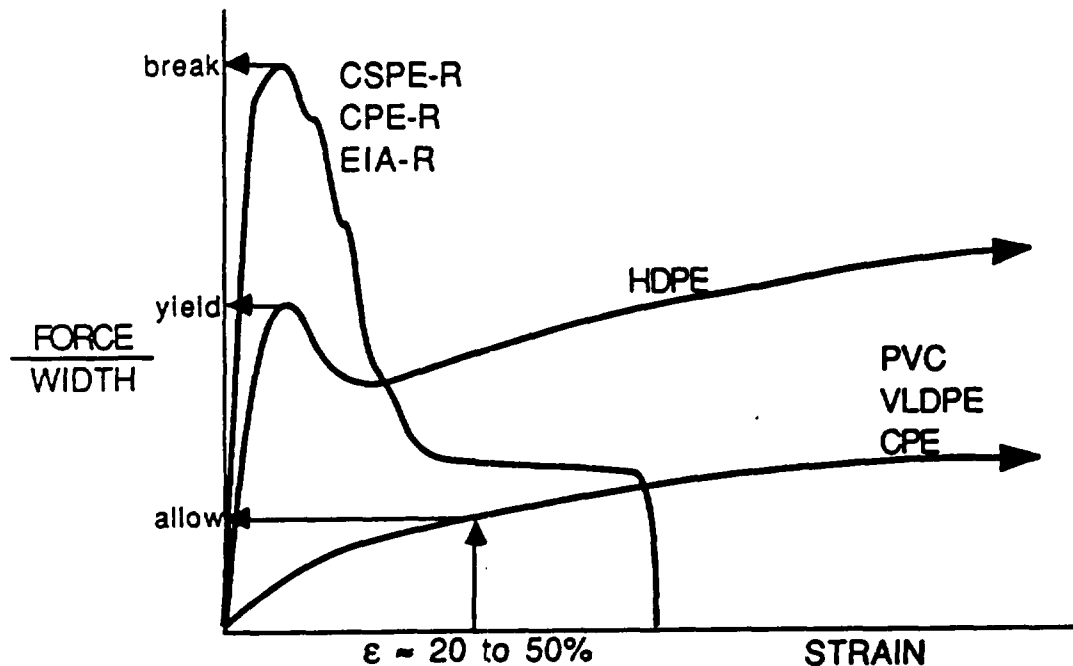

Figure 6 - Tensile Behavior of Various Geomembrane Types

Since there is generally no reduction for partial factors-of-safety in these values of laboratory obtained strength, the final factor-of-safety in the design should be quite conservative. An example problem follows:

**Example Problem:** Given the same landfill cover as described in the previous problems with a geomembrane having an allowable strength of 2000 lb/ft. The shear strength parameters of the geomembrane to the upper soil are  $c_{aU} = 0 \text{ lb/ft}^2$  and  $\delta_U = 14^\circ$  and to the lower soil are  $c_{aL} = 50 \text{ lb/ft}^2$  and  $\delta_L = 5^\circ$ . Calculate the tension in the geomembrane and the

resulting factor-of-safety against geomembrane failure.

Solution:

$$\begin{aligned} T/W &= [(c_{aU} - c_{aL}) + \gamma H \cos \omega (\tan \delta_U - \tan \delta_L)] L \\ &= [(0 - 50) + (120) (3) \cos (18.4^\circ) [\tan (14^\circ) - \tan (5^\circ) ] ] 300 \\ &= [-50 + 55.3] 300 \\ &= 1590 \text{ lb/ft} \end{aligned}$$

$$FS = T_{\text{allow}}/T_{\text{reqd}}$$

$$= \frac{2000}{1590}$$

FS = 1.25, which is barely acceptable.

Note: An alternative design to the above is to bench the cover soil (thereby decreasing the slope length) or use a liner whose lower surface has a higher adhesion or a higher friction surface, than the one used in the example thereby increasing " $c_{aL}$ " and/or " $\delta_L$ ".

Model #4: Geomembrane Tension Stresses Due to Subsidence

Whenever subsidence occurs beneath a geomembrane and it is supporting a cover soil some induced tensile stresses will occur due to out-of-plane forces from the overburden. Such subsidence is actually to be expected in closure situations above completed or abandoned landfills where the underlying waste is generally poorly compacted. The magnitude of the induced tensile stresses in the geomembrane depends upon the dimensions of the subsidence zone and on the cover soil properties.

The general scheme is shown in Figure 7 where the critical assumption is the shape of the deformed geomembrane. In the analysis which is provided in Appendix "D", the deformed shape is that of a spheroid of gradually decreasing center point along the symmetric axis of the deformed geomembrane.<sup>(9)</sup> As a worst case assumption, the geomembrane is assumed to be fixed at the circumference of the subsidence zone. The required tensile force in the geomembrane can be solved in terms of a force per unit width "T<sub>reqd</sub>", or as a stress, i.e. "σ<sub>reqd</sub>". The latter will be used in this analysis since it will be compared to a laboratory test method resulting in the compatible term. The necessary design equation is as follows where the specific terms are given in Figure 7.

$$\sigma_{reqd} = \frac{2 DL^2 \gamma_{cs} H_{cs}}{3 t (D^2 + L^2)} \tag{8}$$

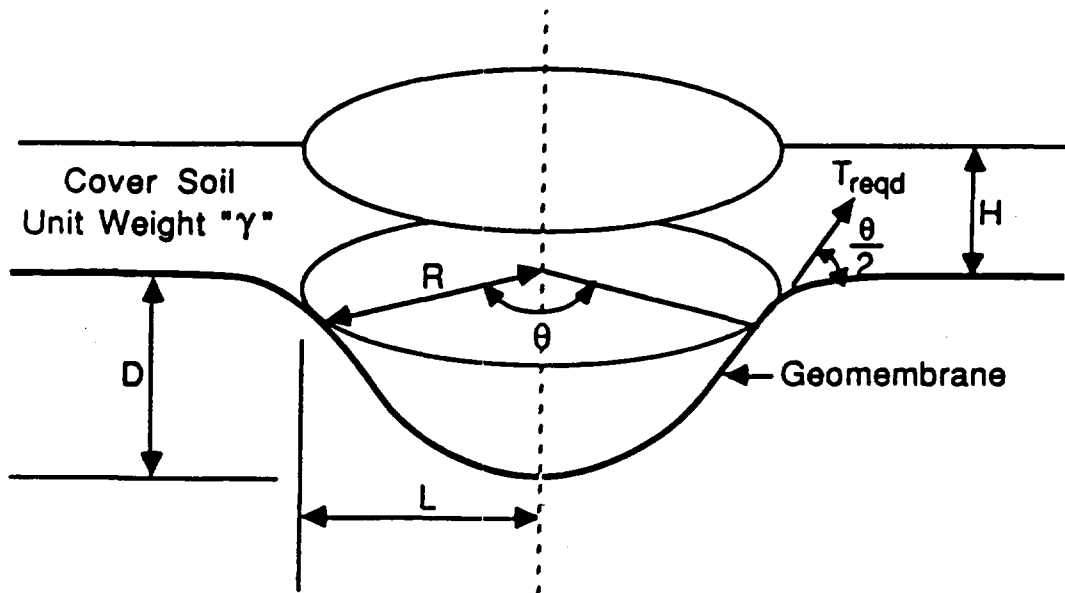

Figure 7 - Tensile Stresses in a Geomembrane Mobilized by Cover Soil and Caused by Subsidence

Upon calculating the value of  $\sigma_{reqd}$  for the site specific situation under consideration, it is compared to an appropriate laboratory simulation test. Recommended at this time is a three-dimensional, out-of-plane, tension test of the same configuration as Figure 6. It is available as GRI Test Method GM-4.<sup>(10)</sup> Thus the formulation for the final factor-of-safety becomes the following:

$$FS = \sigma_{allow} / \sigma_{reqd} \quad (7)$$

Since the value of  $\sigma_{allow}$  is used directly from the test method without any reduction in the form of partial factors-of-safety, relatively conservative values should be required. An example problem follows:

**Example Problem:** Given the same cover soil situation as in the previous example, except now a local subsidence occurs which is estimated to be 1.0 ft deep by 3.0 ft radius. The geomembrane is 40 mils thick has a  $\sigma_{allow}$  of 1000 lb/in<sup>2</sup>. Determine the factor-of-safety of the geomembrane against the mobilized tensile stresses.

**Solution:**

$$\begin{aligned} \sigma_{reqd} &= \frac{2 DL^2 \gamma_{cs} H_{cs}}{3 t (D^2 + L^2)} \\ &= \frac{2 (1.0) (3.0)^2 (120) (3.0)}{3 (0.040/12) [(1.0)^2 + (3.0)^2]} \\ &= 64,800 \text{ lb/ft}^2 \\ \sigma_{reqd} &= 450 \text{ lb/in}^2 \\ FS &= \sigma_{allow} / \sigma_{reqd} \\ &= 1000 / 450 \\ &= 2.2, \text{ which is acceptable} \end{aligned}$$

## Summary and Conclusions

The occurrence of cover soils sliding off geomembrane lined slopes is not an infrequent incident. While less obvious, but of even greater concern, there are often tensile stresses imposed on the underlying geomembrane. The occurrence of extensive tensile failures of geomembranes on side slopes is also known to have occurred. This paper is focused toward a series of four design models to be used to analyze various aspects of the situation.

The first model considered the cover soil's stability by itself. The design procedure is straightforward but it does require a set of carefully generated direct shear tests to realistically obtain the interface friction parameters.

The growing tendency toward steeper and longer slope angles gives rise to the second design model which is veneer reinforcement of the cover soil. Geogrids and geotextiles have shown that they can nicely reinforce the cover soil and the first design example was modified accordingly. The design leads to the calculation of the required tensile strength of the reinforcement. This value must then be compared to a laboratory generated wide width tensile strength of the candidate reinforcement material. It is important in this regard to consider long term implications which can be addressed by partial factors-of-safety.

Both of the above analyses serve to set up the third design scenario, that being a calculation procedure for determination of the induced tensile stresses in the underlying geomembrane brought on by unbalanced friction values. Whenever the frictional characteristics beneath the liner are low (e.g., when the liner is placed on a high moisture clay soil as it is in a composite liner), this type of analysis should be performed. The tensile stress in the geomembrane is then compared to the wide width tensile strength of the geomembrane for its resulting factor-of-safety.

Lastly, a design procedure for calculation of out-of-plane generated tensile stresses in the geomembrane was developed. This situation could readily arise by subsidence of solid waste beneath the geomembrane. The resulting tensile stresses in the geomembrane must then be compared to a properly simulated laboratory test for the factor-of-safety. Such three dimensional axis-symmetric test procedures are currently available.

Each of the four above described models along with their design/analysis procedures were illustrated by means of an example problem dealing with a cover soil in a solid waste closure situation. This type of application is the primary focus of the paper. However, similar situations can arise elsewhere. For example, the same situation occurs in the case of gravel covered primary geomembrane liners on the side slopes of unfilled, or partially filled, landfills. These slopes may have to be exposed to the elements for many years until the waste

provides sufficient passive resistance and final stability. In the meantime, cover soil instability will cause sloughing and can expose the geomembrane to ultraviolet light, high temperatures via direct exposure, and a significantly shortened lifetime.

Hopefully, the use of design models such as presently here (and elsewhere), coupled with the appropriate test method simulating actual field behavior, will lead to recognition of the problems encountered and to a widespread rational design of cover soils on geomembrane lined side slopes.

## References

1. Martin, J. P., Koerner, R. M. and Whitty, J. E., "Experimental Friction Evaluation of Slippage Between Geomembranes, Geotextiles and Soils." Proc. Intl. Conf. on Geomembranes, IFAI, Denver, CO, 1984, pp. 191-196.
2. Koerner, R. M., Martin, J. P. and Koerner, G. R., "Shear Strength Parameters Between Geomembranes and Cohesive Soils," Jour. Geotex. and Geomem., Vol. 4, 1986, pp. 21-30.
3. Mitchell, J. K., Seed, R. B. and Seed, H. B., "Kettleman Hills Waste Landfill Slope Failure. I - Liner-System Properties," Jour. Geotechnical Engineering, Vol. 116, No. 4, April 1990, pp. 647-660.
4. -----, Manual EM 1110-1902, U. S. Army Corps of Engineers, Washington, DC, 1960.
5. Giroud, J. P. and Beech, J. F., "Stability of Soil Layers on Geosynthetic Lining Systems," Geosynthetics '89 Conference, San Diego, CA, IFAI, 1989, pp. 35-46.
6. Giroud, J. P., Bonaparte, R., Beech, J. F. and Gross, B. A., "Design of Soil Layer - Geosynthetic Systems Overlying Voids," Journal of Geotextiles and Geomembranes, Vol. 9, No. 1, 1990, Elsevier, pp. 11-50.
7. Koerner, R. M., Designing with Geosynthetics, 2nd Edition, Prentice Hall Publ. Co., Englewood Cliffs, NJ, 1990, 652 pgs.
8. -----, Standard Test Method for Determining Performance Strength of Geomembranes by the Wide Strip Tensile Method," ASTM Draft Designation D35.10.86.02 (in task group status).
9. Koerner, R. M., Koerner, G. R. and Hwu, B-L, "Three Dimensional, Axis-Symmetric Geomembrane Tension Test," *Geosynthetic Testing for Waste Containment Applications*, ASTM STP 1081, Robert M. Koerner, Editor ASTM, Philadelphia, PA, 1990.
10. -----, GRI Test Method GM-4, "Three Dimensional Geomembrane Tension Test," Geosynthetic Research Institute, Philadelphia PA, 1989.

## Appendix "A"

### Derivation of FS for Cover Soil Stability on a Geomembrane

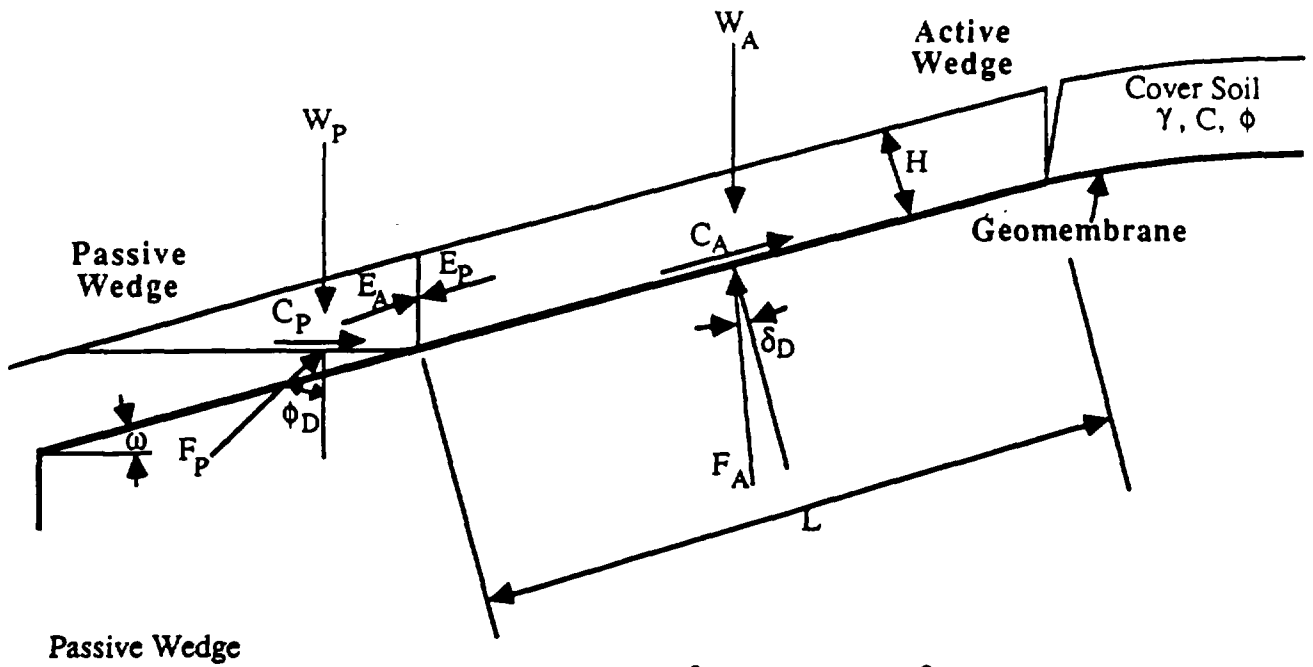

$$W_P = \frac{1}{2} \gamma \frac{H^2}{\sin \omega \cos \omega} = \frac{\gamma H^2}{\sin 2\omega}$$

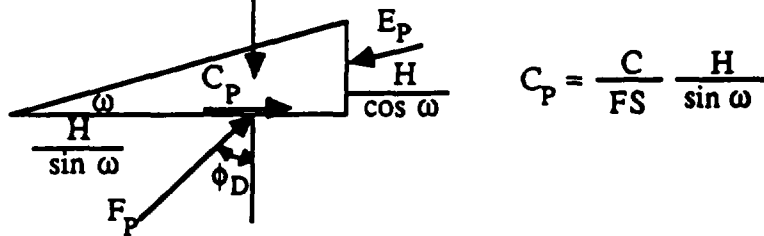

$$C_P = \frac{C}{FS} \frac{H}{\sin \omega}$$

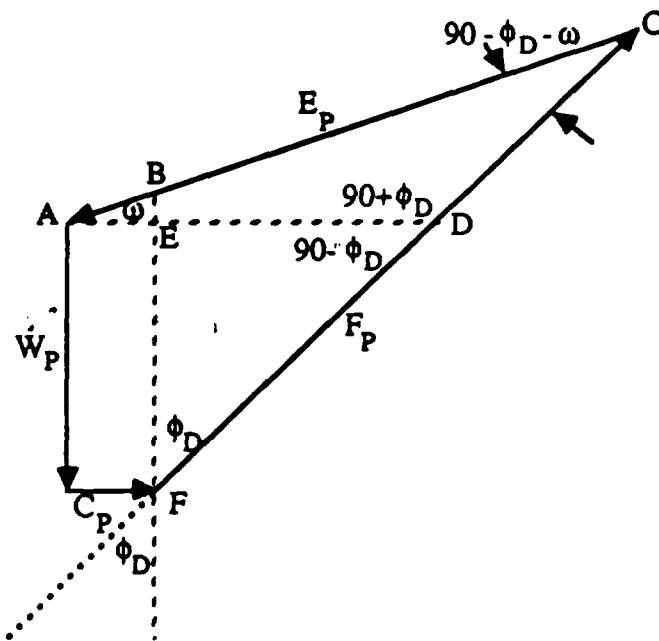

### Passive Wedge

$$\overline{EF} = W_p$$

$$\frac{\overline{DE}}{\sin \phi_D} = \frac{\overline{EF}}{\sin (90^\circ - \phi_D)} = \frac{W_p}{\cos \phi_D}$$

$$\overline{DE} = W_p \cdot \tan \phi_D$$

$$\frac{E_p}{\sin (90^\circ + \phi_D)} = \frac{\overline{AD}}{\sin (90^\circ - \phi_D - \omega)}$$

$$\frac{E_p}{\cos \phi_D} = \frac{C_p + W_p \cdot \tan \phi_D}{\cos (\phi_D + \omega)}$$

$$E_p = \frac{\cos \phi_D \cdot [C_p + W_p \cdot \tan \phi_D]}{\cos (\phi_D + \omega)}$$

$$= \frac{\cos \phi_D \cdot \left[ \frac{C}{FS} \cdot \frac{H}{\sin \omega} + \frac{\gamma \cdot H^2}{\sin 2\omega} \cdot \tan \phi_D \right]}{\cos (\phi_D + \omega)}$$

$$= \frac{\cos \phi_D}{(\cos \phi_D \cos \omega - \sin \phi_D \sin \omega)} \left[ \frac{C \cdot H}{FS \cdot \sin \omega} + \frac{\gamma \cdot H^2}{2 \sin \omega \cos \omega} \cdot \frac{\tan \phi}{FS} \right]$$

$$= \frac{1}{(\cos \omega - \tan \phi_D \sin \omega)} \left[ \frac{2 \cdot C \cdot H \cdot \cos \omega + \gamma \cdot H^2 \cdot \tan \phi}{2 \cdot \sin \omega \cdot \cos \omega \cdot FS} \right]$$

$$= \frac{FS}{(FS \cdot \cos \omega - \tan \phi \cdot \sin \omega)} \left[ \frac{2 \cdot C \cdot H \cdot \cos \omega + \gamma \cdot H^2 \cdot \tan \phi}{2 \cdot \sin \omega \cdot \cos \omega \cdot FS} \right]$$

Active Wedge

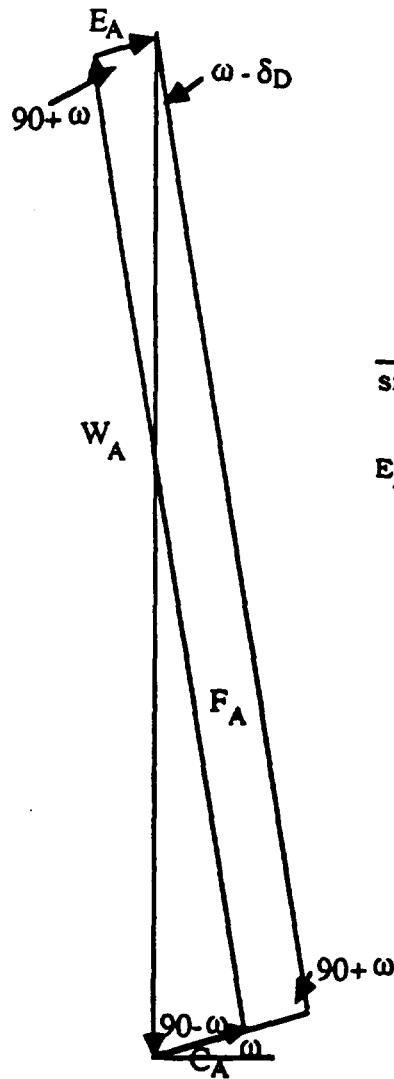
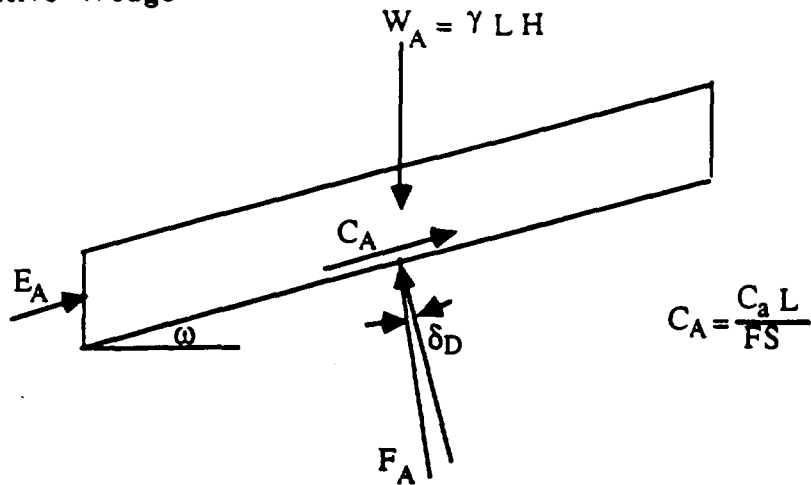

$$\frac{E_A + C_A}{\sin(\omega - \delta_D)} = \frac{W_A}{\sin(90^\circ + \delta_D)} = \frac{W_A}{\cos \delta_D}$$

$$E_A = \frac{W_A \sin(\omega - \delta_D)}{\cos \delta_D} - C_A$$

$$= \frac{W_A [\sin \omega \cos \delta_D - \cos \omega \sin \delta_D]}{\cos \delta_D} - C_A$$

$$= \gamma \cdot L \cdot H (\sin \omega - \cos \omega \tan \delta_D) - \frac{C_a \cdot L}{FS}$$

$$E_A = E_p$$

$$\gamma \cdot L \cdot H \cdot (\sin \varpi - \cos \varpi \cdot \tan \delta_D) - \frac{C_a \cdot L}{FS} = \frac{(2 \cdot C \cdot H \cdot \cos \varpi + \gamma \cdot H^2 \cdot \tan \phi)}{(FS \cdot \cos \varpi - \tan \phi \cdot \sin \varpi) \cdot (\sin 2\varpi)}$$

$$\gamma \cdot L \cdot H \cdot \left( \sin \varpi - \frac{\cos \varpi \cdot \tan \delta}{FS} \right) - \frac{C_a \cdot L}{FS} = \frac{(2 \cdot C \cdot H \cdot \cos \varpi + \gamma \cdot H^2 \cdot \tan \phi)}{(FS \cdot \cos \varpi - \tan \phi \cdot \sin \varpi) \cdot (\sin 2\varpi)}$$

$$\frac{\gamma \cdot L \cdot H \cdot (\sin \varpi \cdot FS - \cos \varpi \cdot \tan \delta) - C_a \cdot L}{FS} = \frac{(2 \cdot C \cdot H \cdot \cos \varpi + \gamma \cdot H^2 \cdot \tan \phi)}{(FS \cdot \cos \varpi \cdot \sin 2\varpi - \tan \phi \cdot \sin \varpi \cdot \sin 2\varpi)}$$

$$\frac{\gamma \cdot L \cdot H \cdot \sin \varpi \cdot FS - \gamma \cdot L \cdot H \cdot \cos \varpi \cdot \tan \delta - C_a \cdot L}{FS} = \frac{(2 \cdot C \cdot H \cdot \cos \varpi + \gamma \cdot H^2 \cdot \tan \phi)}{(FS \cdot \cos \varpi \cdot \sin 2\varpi - \tan \phi \cdot \sin \varpi \cdot \sin 2\varpi)}$$

$$FS^2 \cdot (\gamma \cdot L \cdot H \cdot \sin \varpi \cdot \cos \varpi \cdot \sin 2\varpi) - FS \cdot (\gamma \cdot L \cdot H \cdot \cos^2 \varpi \cdot \tan \delta \cdot \sin 2\varpi)$$

$$- FS \cdot (C_a \cdot L \cdot \cos \varpi \cdot \sin 2\varpi) - FS \cdot (\gamma \cdot L \cdot H \cdot \sin^2 \varpi \cdot \tan \phi \cdot \sin 2\varpi)$$

$$+ (\gamma \cdot L \cdot H \cdot \cos \varpi \cdot \tan \delta + C_a \cdot L) \cdot (\tan \phi \cdot \sin \varpi \cdot \sin 2\varpi) = FS \cdot (2 \cdot C \cdot H \cdot \cos \varpi + \gamma \cdot H^2 \cdot \tan \phi)$$

$$FS^2 \cdot \left( \frac{1}{2} \cdot \gamma \cdot L \cdot H \cdot \sin^2 2\varpi \right) - FS \cdot (\gamma \cdot L \cdot H \cdot \cos^2 \varpi \cdot \tan \delta \cdot \sin 2\varpi + C_a \cdot L \cdot \cos \varpi \cdot \sin 2\varpi)$$

$$+ \gamma \cdot L \cdot H \cdot \sin^2 \varpi \cdot \tan \phi \cdot \sin 2\varpi + 2 \cdot C \cdot H \cdot \cos \varpi + \gamma \cdot H^2 \cdot \tan \phi$$

$$+ (\gamma \cdot L \cdot H \cdot \cos \varpi \cdot \tan \delta + C_a \cdot L) \cdot (\tan \phi \cdot \sin \varpi \cdot \sin 2\varpi) = 0$$

**Appendix "B"**  
**Derivation of Required Tensile Strength of Geogrid or Geotextile Reinforcement of Cover Soil on a Geomembrane**

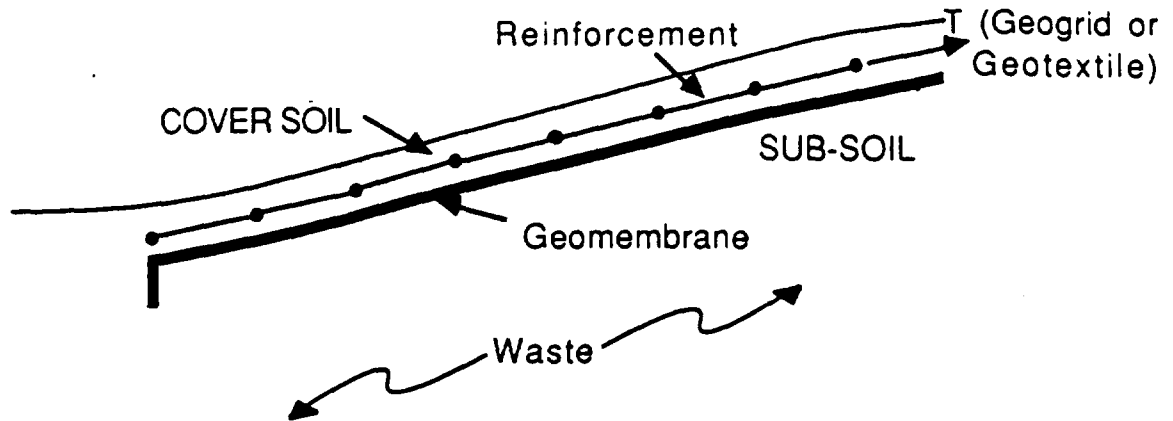

$$E_p + T = E_A \Rightarrow T = E_A - E_p$$

$$E_A = \frac{\gamma \cdot L \cdot H \cdot \sin(\varpi - \delta_D)}{\cos \delta_D} - C_A$$

$$E_p = \frac{\cos \phi_D \cdot \left[ \frac{C}{FS} \cdot \frac{H}{\sin \varpi} + \frac{\gamma \cdot H^2}{\sin 2\varpi} \cdot \tan \phi_D \right]}{\cos(\phi_D + \varpi)}$$

$$FS = 1, \delta_D = \delta, \phi_D = \phi$$

$$T_{reqd} = \frac{\gamma \cdot L \cdot H \cdot \sin(\varpi - \delta)}{\cos \delta} - C_A - \frac{\cos \phi \cdot \left[ \frac{C \cdot H}{\sin \varpi} + \frac{\gamma \cdot H^2}{\sin 2\varpi} \cdot \tan \phi \right]}{\cos(\phi + \varpi)}$$

**Appendix "C"**  
**Derivation of Geomembrane Tensile Stress**  
**Due to Unbalanced Friction Forces**

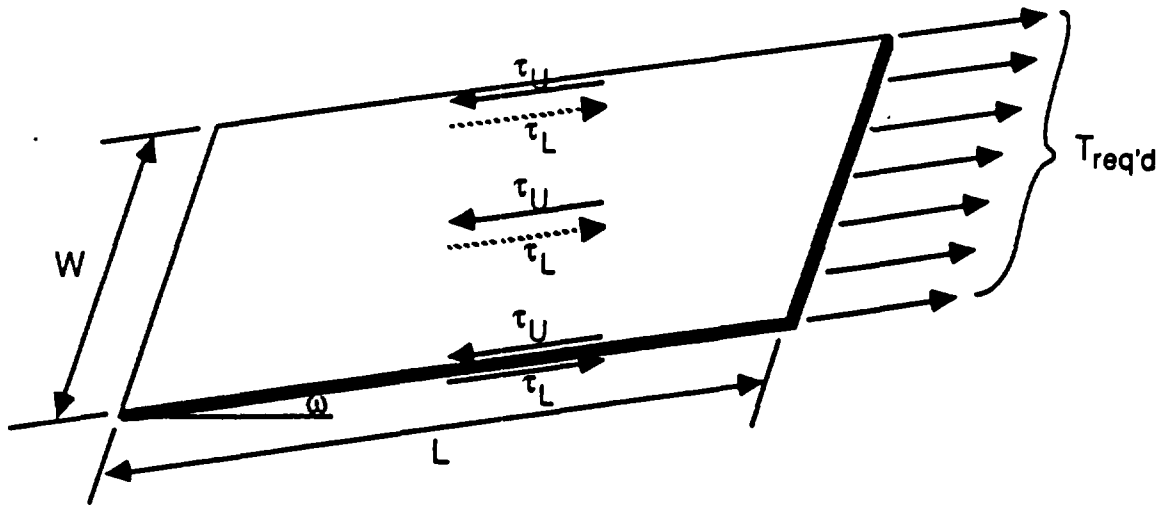

$$FS = \frac{\text{Resisting Force}}{\text{Driving Force}} = \frac{T + \tau_L \cdot W \cdot L}{\tau_U \cdot W \cdot L}$$

- (a) If  $\tau_U = \tau_L$ ,  $FS > 1$ , pure shear @  $\tau_U = \tau_L$
- (b) If  $\tau_U < \tau_L$ ,  $FS > 1$ , pure shear =  $\tau_U$ , rest of  $(\tau_L - \tau_U)$  is not mobilized.
- (c) If  $\tau_U > \tau_L$ ,  $FS$  may be  $>$ ,  $=$  or  $< 1$ , which depend on the  $T$  value

$$\text{when } FS = 1 \Rightarrow \tau_U \cdot W \cdot L = T + \tau_L \cdot W \cdot L$$

$$T = \tau_U \cdot W \cdot L - \tau_L \cdot W \cdot L$$

$$\frac{T}{W} = (\tau_U - \tau_L) \cdot L$$

$$\tau = C + \sigma_n \cdot \tan \phi, \sigma_n = \gamma \cdot H \cdot \cos \omega$$

$$\tau_U = C_{aU} + \gamma \cdot H \cdot \cos \omega \cdot \tan \delta_U$$

$$\tau_L = C_{aL} + \gamma \cdot H \cdot \cos \omega \cdot \tan \delta_L$$

$$\frac{T}{W} = [(C_{aU} - C_{aL}) + \gamma \cdot H \cdot \cos \omega \cdot (\tan \delta_U - \tan \delta_L)] \cdot L$$

$$FS = \frac{\sigma_{\text{allow}}}{\sigma_{\text{reqd}}}$$

$$\text{where } \sigma_{\text{allow}} = \frac{\sigma_{\text{ult}}}{(FS)_T}$$

$\sigma_{\text{ult}}$  = Geomembrane Wide Width Tensile Test

$$\sigma_{\text{reqd}} = \left( \frac{T}{W} \right) \cdot \left( \frac{1}{t} \right)$$

Appendix "D"  
 Derivation of Geomembrane Tensile Stress Due to  
 Subsidence of Material Beneath the Geomembrane

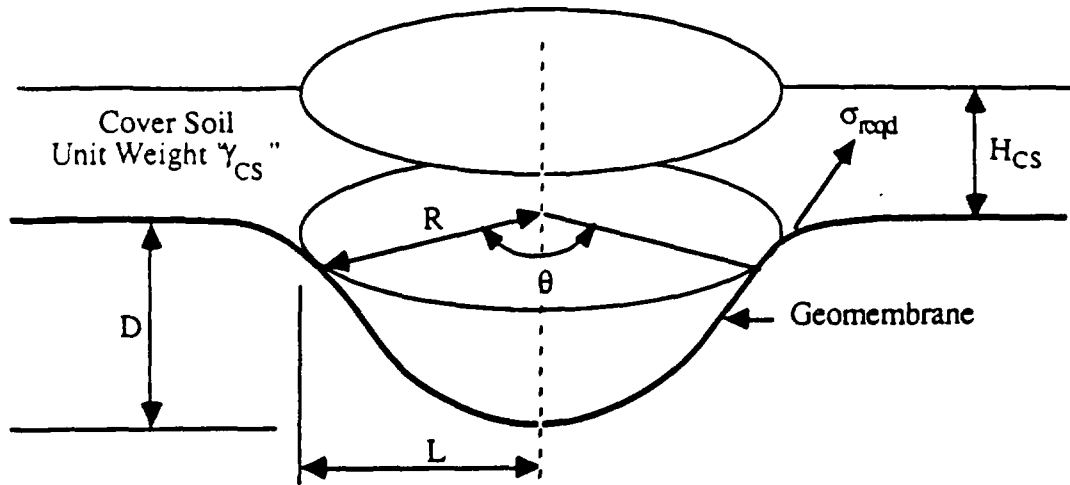

$$C \text{ (circumference)} = 2 \cdot \pi \cdot L$$

$t$  = thickness of the geomembrane

$$R^2 = (R - D)^2 + L^2 \Rightarrow R^2 = R^2 - 2 \cdot R \cdot D + D^2 + L^2$$

$$R = \frac{D^2 + L^2}{2 \cdot D}$$

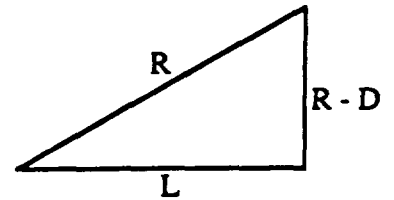

$$\int_0^L (2 \cdot \pi \cdot r) \cdot dr \cdot \gamma_{cs} \cdot H_{cs} \cdot r = \sigma_{reqd} \cdot t \cdot C \cdot R$$

$$\frac{2}{3} \cdot \pi \cdot L^3 \cdot \gamma_{cs} \cdot H_{cs} = \sigma_{reqd} \cdot t \cdot (2 \cdot \pi \cdot L) \cdot R$$

$$\sigma_{reqd} = \frac{\frac{2}{3} \cdot \pi \cdot L^3 \cdot \gamma_{cs} \cdot H_{cs}}{t \cdot (2 \cdot \pi \cdot L) \cdot R}$$

$$= \frac{L^2 \cdot \gamma_{cs} \cdot H_{cs}}{3 \cdot t \cdot R}$$

$$\sigma_{reqd} = \frac{2 \cdot D \cdot L^2 \cdot \gamma_{cs} \cdot H_{cs}}{3 \cdot t \cdot (D^2 + L^2)}$$

**APPENDIX B**  
**LONG-TERM DURABILITY AND AGING OF GEOMEMBRANES**

The paper summarizes the different geomembrane degradation processes and then concludes with some suggested procedures on long-term simulation testing coupled with observations on field behavior.

### Overview of Geomembranes

Beginning with swimming pool liners (Staff 1984) made from PVC sheeting in the 1930's, and extending to bituminous panels (Geier and Morrison 1968) for canal liners, the geomembrane era began in earnest with reservoir liners made from butyl rubber (Chuck 1970) in the 1950's. These thermoset elastomers were made from synthetic rubber which was developed during World War II. To date, some manufacturers still refer to geomembranes as "pond liners". Other names have also arisen; for example, flexible membrane liners (FML's), a term used extensively by the U.S. EPA, synthetic membrane liners (SML's), membrane liners, or, simply, liners. Being a subset of the geosynthetics area, we will refer to them as geomembranes. ASTM defines geomembranes as "an essentially impermeable membrane used with foundation, soil, rock, earth or any other geotechnical engineering related material as an integral part of a man-made project, structure or system".

Throughout the 1960's and the 1970's a tremendous variety of geomembrane formulations were developed. They were so plentiful that they almost defied classification. Many were blends of polymers and even blends of polymers and nonpolymers. Copolymers were developed which gave additional options. Even the manufacturing process gave rise to many variations. The EPA Technical Guidance Document (Matrecon, Inc. 1988) and Kay's book (1988) gives some insight into the varieties of geomembranes available during this period. The major use of geomembranes, however, did not arrive until 1982 when the U.S. EPA required that a liner must "prevent" pollution migration, rather than only "minimize" pollution migration (U.S. Federal Register 1982). This legislation essentially required the use of FML's, or geomembranes, as being preferred over clay liners.

Regarding the culling out of the large variety of geomembrane types existing at that time, another EPA document, this time in the form of a test protocol, was significant. In 1984, EPA decided that a test method for chemical compatibility, or resistance, was necessary so that all EPA Regions and State Environmental Departments would be permitting candidate geomembranes against the same test standard. This test method, known as EPA Method 9090 (U.S. EPA 1984), has had the effect of greatly reducing the many possible types of geomembranes in

### Long-Term Durability and Aging of Geomembranes

Robert M. Koerner<sup>1</sup>, Yick H. Halse<sup>2</sup> and  
Arthur E. Lord, Jr.<sup>3</sup>

#### Abstract

Perhaps the most frequently asked question regarding geomembranes (or any other type of geosynthetic material) is, "how long will they last"? The answer to this question is illusive (in spite of a relatively large data base on polymer degradation) mainly because of the buried nature of geomembranes. Soil burial greatly diminishes, and even eliminates many of the degradation processes and synergistic effects which have been most widely investigated by the polymer industry for exposed plastics. However, different degradation processes coming from chemical interactions and extremely long time frames may be involved via exposure to liquids like leachate for systems intended to last for many decades or even hundreds of years. Thus the lifetimes of buried geomembranes can be significantly different than exposed plastics, but a quantitative method to predict "how long" is still not available.

This paper describes the various degradation mechanisms of plastics on an individual basis and then addresses the various synergistic effects which may accelerate degradation. It will be seen that synergistic effects greatly complicate the situation. While accelerated test methods are attractive to assess the various phenomena, these procedures may significantly misrepresent the actual long-term performance of geomembranes. Thus the transfer of information must proceed with caution.

<sup>1</sup>Bowman Professor of Civil Engineering and Director, Geosynthetic Research Institute, Drexel University Philadelphia, PA, 19104.

<sup>2</sup>Research Assistant Professor, Geosynthetic Research Institute, Drexel University, Philadelphia, PA, 19104.

<sup>3</sup>Professor of Physics, Geosynthetic Research Institute, Drexel University, Philadelphia, PA, 19104.

The paper summarizes the different geomembrane degradation processes and then concludes with some suggested procedures on long-term simulation testing coupled with observations on field behavior.

### Overview of Geomembranes

Beginning with swimming pool liners (Staff 1984) made from PVC sheeting in the 1930's, and extending to bituminous panels (Geier and Morrison 1968) for canal liners, the geomembrane era began in earnest with reservoir liners made from butyl rubber (Chuck 1970) in the 1950's. These thermoset elastomers were made from synthetic rubber which was developed during World War II. To date, some manufacturers still refer to geomembranes as "pond liners". Other names have also arisen; for example, flexible membrane liners (FML's), a term used extensively by the U.S. EPA, synthetic membrane liners (SML's), membrane liners, or, simply, liners. Being a subset of the geosynthetics area, we will refer to them as geomembranes. ASTM defines geomembranes as "an essentially impermeable membrane used with foundation, soil, rock, earth or any other geotechnical engineering related material as an integral part of a man-made project, structure or system".

Throughout the 1960's and the 1970's a tremendous variety of geomembrane formulations were developed. They were so plentiful that they almost defied classification. Many were blends of polymers and even blends of polymers and nonpolymers. Copolymers were developed which gave additional options. Even the manufacturing process gave rise to many variations. The EPA Technical Guidance Document (Matrecon, Inc. 1988) and Kay's book (1988) gives some insight into the varieties of geomembranes available during this period. The major use of geomembranes, however, did not arrive until 1982 when the U.S. EPA required that a liner must "prevent" pollution migration, rather than only "minimize" pollution migration (U.S. Federal Register 1982). This legislation essentially required the use of FML's, or geomembranes, as being preferred over clay liners.

Regarding the culling out of the large variety of geomembrane types existing at that time, another EPA document, this time in the form of a test protocol, was significant. In 1984, EPA decided that a test method for chemical compatibility, or resistance, was necessary so that all EPA Regions and State Environmental Departments would be permitting candidate geomembranes against the same test standard. This test method, known as EPA Method 9090 (U.S. EPA 1984), has had the effect of greatly reducing the any possible types of geomembranes in

### Long-Term Durability and Aging of Geomembranes

Robert M. Koerner<sup>1</sup>, Yick H. Halse<sup>2</sup> and  
Arthur E. Lord, Jr.<sup>3</sup>

#### Abstract

Perhaps the most frequently asked question regarding geomembranes (or any other type of geosynthetic material) is, "how long will they last"? The answer to this question is illusive (in spite of a relatively large data base on polymer degradation) mainly because of the buried nature of geomembranes. Soil burial greatly diminishes, and even eliminates many of the degradation processes and synergistic effects which have been most widely investigated by the polymer industry for exposed plastics. However, different degradation processes coming from chemical interactions and extremely long time frames may be involved via exposure to liquids like leachate for systems intended to last for many decades or even hundreds of years. Thus the lifetimes of buried geomembranes can be significantly different than exposed plastics, but a quantitative method to predict "how long" is still not available.

This paper describes the various degradation mechanisms of plastics on an individual basis and then addresses the various synergistic effects which may accelerate degradation. It will be seen that synergistic effects greatly complicate the situation. While accelerated test methods are attractive to assess the various phenomena, these procedures may significantly misrepresent the actual long-term performance of geomembranes. Thus the transfer of information must proceed with caution.

<sup>1</sup>Bowman Professor of Civil Engineering and Director, Geosynthetic Research Institute, Drexel University Philadelphia, PA, 19104.

<sup>2</sup>Research Assistant Professor, Geosynthetic Research Institute, Drexel University, Philadelphia, PA, 19104.

<sup>3</sup>Professor of Physics, Geosynthetic Research Institute, Drexel University, Philadelphia, PA, 19104.

current use, particularly those used for pollution control. The test method has a parallel document directed at assessing the test results, which is in the form of an expert computer system called FLEX (U.S. EPA 1987). In the next section, characterization of the most widely used geomembranes is presented.

#### Types and Properties of Commonly Used Geomembranes

With the initial caution that polymer formulation and processing is an on-going and constantly changing technology, we will attempt to categorize the geomembranes that are in common use. To be noted, however, is that our perspective is from a geosynthetic engineering design point of view. A different grouping would indeed occur from a polymer chemist's or compound formulator's perspective.

(a) Stiff (Semi-Crystalline) Thermoplastic Geomembranes - In the stiff, semi-crystalline, thermoplastic category are those geomembranes with crystallinity near, or above, 50% which results in stiffness values of greater than 1000 g-cm as per the ASTM D-1388 flexural rigidity test. This is a bending test developed for fabrics, but it can be readily used to distinguish stiff-from-flexible geomembranes.

By far the most important geomembrane in this category is high density polyethylene (HDPE). There are a number of variations within HDPE, an important one being the development of textured sheet which results in a high friction surface. Also coextrusion manufacturing can result in very intriguing composite materials with the basic sheet being HDPE.

As a polymer formulation, HDPE is almost pure polyethylene resin (about 97%), in the 0.935 to 0.937 g/cc density range. When carbon black is added for ultraviolet stability, however, the material's overall density is at, or slightly above, the 0.941 g/cc lower limit of ASTM definition of high density polyethylene. Thus it is commonly referred to as HDPE. The balance of the compound is 2.0% to 2.5% carbon black and the remaining 1.0% to 0.5% is antioxidant and processing aids. The processing aids provide viscosity control, manufacturing lubrication, and prevent adhesion between various surfaces. They have also been called viscosity depressants, slip agents and antiblocking agents. They are generally proprietary as to their exact chemical compositions. It should also be noted that the polyethylene resins themselves have certain uniquenesses, particularly the nature and extent of tie molecule bonding and branching.

(b) Flexible (Low Crystallinity) Thermoplastic Geomembranes - This group of geomembranes is characterized by stiffness values in the ASTM D-1388 flexural rigidity test as being significantly lower than 1000 g-cm. The main geomembranes in this category are PVC, CPE, CSPE and VLDPE. Some typical values of flexural rigidity are the following:

- 0.50 mm polyvinyl chloride (PVC) = 4 g-cm
- 0.75 mm chlorinated polyethylene (CPE) = 20 g-cm
- 0.75 mm chlorosulfonated polyethylene (CSPE) = 25 g-cm
- 0.75 mm very low density polyethylene (VLDPE) = 78 g-cm

While all of the above geomembranes have some crystallinity, it is very low in comparison to HDPE. Yet, all are indeed thermoplastic polymers and can be sealed using thermal methods. The formulations of these materials vary widely. Some typical values follow in Table 1.

Table 1 - Typical Formulations for Flexible, Thermoplastic, Geomembranes

Geo-membrane	Resin (%)	Plasticizer (%)	Carbon Black & Filler (%)	Additive*
PVC	45-50	35-40	10-15	3-5
CPE	60-75	10-15	20-30	3-5
CSPE	45-50	2-5	45-50	2-4
VLDPE**	96-98	0	2-3	1-2

\*refers to antioxidant, processing aids and lubricants

\*\*note that this formulation is typical of most polyethylenes, including HDPE

(c) Reinforced, Flexible (Low Crystallinity) Thermoplastic Geomembranes - The behavior of geomembranes when they are fabric reinforced (either via an internal scrim or via spread coating) is very different than the unreinforced variety of the exact same polymer. Certainly the short-term engineering design properties are greatly altered and conceivably the long-term properties may be altered as well. The geomembranes are indeed flexible, however, as the following data indicates. The stiffness values

indicated are via the ASTM D-1388 test for flexural rigidity:

- 0.91 mm chlorinated polyethylene (CPE-R) - 25 g-cm
- 0.91 mm chlorosulfonated polyethylene (CSPE-R) - 30 g-cm
- 0.66 mm ethylene interpolymer alloy (EIA-R) - 60 g-cm

As with the unreinforced materials just mentioned, all can be seamed using thermal methods and are truly thermoplastic. The formulations of the polymer component are the same as given in Table 1.

Regarding the type of fabric used for the scrim reinforcement of CPE-R and CSPE-R there are many possibilities. Woven fabrics of high tenacity polyester or nylon are the most common. They are often in a pattern of 10 yarns per inch (4 yarns per centimeter) in both directions, which is called a 10 x 10 scrim. Other variations are 6 x 6 and 20 x 20 patterns, as well as unbalanced variations. For reinforced geomembranes like EIA-R, a very tightly woven fabric is used. Not specifically mentioned are spread coated fabrics where a variety of nonwoven needlepunched fabrics can be utilized.

(d) Other Geomembranes - While the focus in this paper will be on the geomembranes just reviewed, there are many other possibilities. Two complete groups have been omitted since they are not currently used to any significant degree in North America. They are the thermoset elastomers (Matrecon 1988, Kays 1988) and polymer modified bitumens (Gamski 1984), the latter group being used quite often in Europe. Other newer materials which fall within the categories just mentioned are in the development stage and undoubtedly more will appear in the future. This review, however, will be sufficient to build upon in describing the various degradation processes and synergistic effects which may occur.

#### Mechanisms of Degradation

This section of the paper describes various polymer degradation processes which can act within a geomembrane. Each process and its resulting implication is taken by itself as though it were acting in isolation. This, of course, is not field representative, but we feel that it is necessary to describe the isolated events before synergistic effects can be considered. Please note at the outset that our perspective is from a geosynthetic engineering design point of view. From a chemistry or polymeric science point of view there are many references treating the various subjects in a much more rigorous (and undoubtedly enlightened) manner.

(a) Ultraviolet Degradation - As shown in Figure 1, the spectrum of natural light is broken into two major regions (visible and ultraviolet) according to the wavelength of the solar radiation. It is well established in the polymer literature that certain wavelengths within the ultraviolet portion are particularly degrading to polymeric materials. Van Zaten (1986) makes mention of the following commonly used polymers and their most sensitive wavelengths, all of which are in the ultraviolet region and are noted on Figure 1.

- polyethylene = 300 nm
- polyester = 325 nm
- polypropylene = 370 nm

Furthermore, the mechanism of degradation is also well understood. The light with the most sensitive wavelengths enters into the molecular structure of the polymer liberating free radicals which cause bond scission in the primary bonding of the polymer's backbone. This mechanism, in direct proportion to the intensity, causes a reduction in mechanical properties to the eventual point where the polymer becomes brittle and cracks to unacceptable levels.

The above type of degradation is greatly reduced by the use of carbon black or chemical based light stabilizers. Carbon black is a finely dispersed powder of approximately micron size which acts as a blocking (or screening) agent to prevent the ultraviolet light from entering into the polymer structure. It also absorbs some of the energy. Its effectiveness decreases uniformly with time of exposure so that the amount and dispersion of the carbon black is important (Apse 1989). The maximum amount, however, is limited to the amount which interferes with the growth and strength of the polymer structure. Hindered amine light stabilizers (HALS) are chemicals added to the polymer compound which react with the free radicals liberated by the ultraviolet light preventing the propagation of degradation. When such additives are consumed, however, continued ultraviolet exposure will cause rapid degradation of the polymer. A combination of carbon black and chemical absorbers has been shown to be very effective in avoiding ultraviolet induced degradation of polymers (Grassie and Scott 1985).

For geomembrane applications, a soil backfill or other covering eliminates the problem of ultraviolet degradation entirely. Only exposed geomembranes are subjected to ultraviolet degradation and as little as 15 cm of soil cover is sufficient to prevent its occurrence. Obviously, this cover soil must be placed in a timely fashion which can be achieved in all except the following

polyethylene and polypropylene geomembranes were unaffected by the radiation. Furthermore, the radiation did not have a significant effect on other chemical degradation rates.

With the absence of radioactive materials in the waste material, however, the subject becomes a moot point. Fortunately, this is the case for most solid and liquid waste contained by geomembranes and related geosynthetic materials.

(c) Chemical Degradation - The reaction of various geomembranes to chemicals has probably been studied more than any other liner degradation mechanism. Most of the work is laboratory oriented via simple immersion tests but the body of knowledge is so great that a reasonable confidence level can be associated with manufacturers listings and recommendations. Complex waste streams like leachate, however, are usually not addressed and must be evaluated on a site specific basis. For this reason the U.S. EPA developed the Method 9090 procedure. Here samples of the candidate geomembrane are exposed at 23°C and at 50°C and removed at 30, 60, 90 and 120 days. Various physical and mechanical tests are performed and then compared to the unexposed geomembrane. A percent change in this behavior is calculated. When plotted for the various exposure times, trends can be established and a decision made as to the nature and degree of chemical resistance.

Depending on the type of leachate vis-a-vis the polymeric compound from which the geomembrane is made, a number of reactions may occur:

- No reaction may occur, which indicates that the geomembrane is resistant to the leachate; at least for the time periods and temperatures evaluated.
- Swelling of the geomembrane may occur which in itself may not be significant. Many polymers can accommodate liquid in their amorphous regions without a sacrifice of physical or mechanical properties. Swelling, however, is often the first stage of subsequent degradation and a small loss in modulus and strength may occur. The effect is often reversible when the liquid is removed.
- Change of physical and mechanical properties, of course, signifies some type of chemical reaction. The variations are enormous. Quite often the elongation at break in a tensile test will be the first property to show signs of change. It will first occur with the 50°C incubation data, since this can be considered to be an accelerated test over the 23°C incubation data.
- A large change of physical and mechanical properties signifies an unacceptable performance of the

geomembrane. Limits of acceptability are, however, very subjective. Table 2 gives a number of recommendations as accumulated by Koerner, 1990. It should be noted that there is also an expert computer code available to aid in the decision.

Table 2 - Suggested Limits of Different Test Values for Incubated Geomembranes, (see the Reference by Koerner, 1990, for other details and complete references)

(a) For Flexible, Low Crystallinity, Thermoplastic Polymers (Unreinforced and Reinforced), after Little

Property	Resistant	Not Resistant
Permeation Rate (water vapor)	<0.9 g/m <sup>2</sup> /hr	>0.9 g/m <sup>2</sup> /hr
Change in weight (%)	<10	>10
Change in volume (%)	<10	>10
Change in tensile strength (%)	<20	>20
Change in elongation at break (%)	<30	>30
Change in 100% or 200% modulus (%)	<30	>30
Change in hardness	10 points	10 points

(b) For Stiff, Semi-Crystalline, Thermoplastic, Polymers

Property	O'Toole		Little		Koerner	
	Resis- tant	Not Resis- tant	Resis- tant	Not Resis- tant	Resis- tant	Not Resis- tant
Permeation Rate (water vapor) (g/m <sup>2</sup> -hr)	-	-	<0.9	≥0.9	<0.9	≥0.9
Change in Weight (%)	<0.5	>1.0	<3	≥3	<2	≥2
Change in Volume (%)	<0.2	>0.5	<1	≥1	<1	≥1
Change in Yield strength (%)	<10	>20	<20	≥20	<20	≥20
Change in Yield Elongation (%)	-	-	<20	≥20	<30	≥30
Change in Modulus (%)	-	-	-	-	<30	≥30
Change in Tear Strength (%)	-	-	-	-	<20	≥20
Change in Puncture Strength (%)	-	-	-	-	<30	≥30

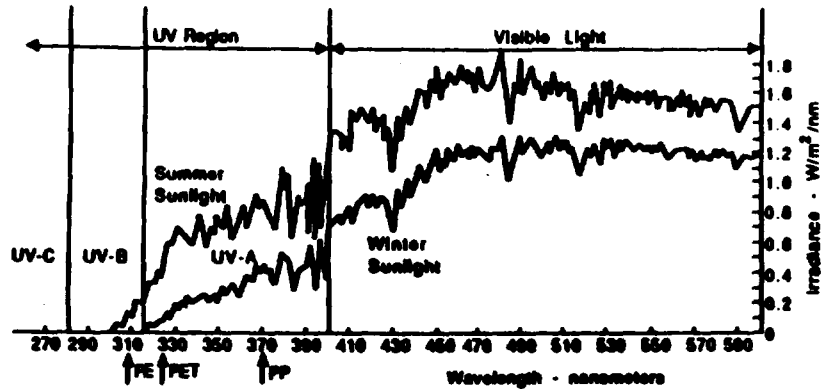

Figure 1 - The Wavelength Spectrum of Visible and UV Solar Radiation.

B-6

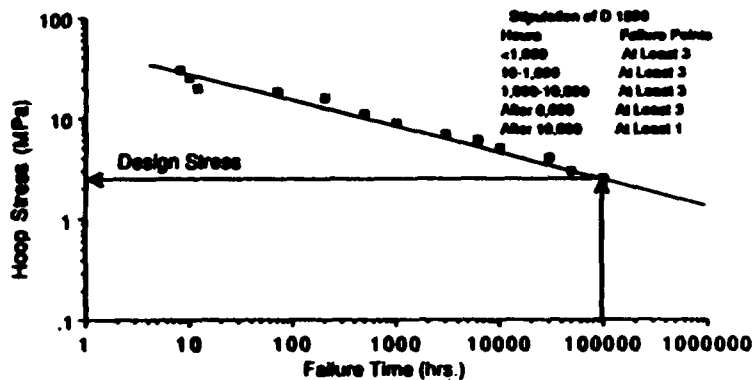

Figure 2 - Schematic Plot of Time of Failure versus Pipe Hoop Stress for Burst Testing of Un-Notched PE Pipe.

situations.

- Surface impoundments above the liquid level and along their horizontal runout length
- Canal liners above the liquid level and along their horizontal runout length
- Covers of surface impoundments, i.e., floating covers
- Landfill liners on side slopes which have had their surfaces exposed by erosion of cover soil and are inaccessible.

For the above situations of exposed geomembranes some amount of degradation over time is unavoidable.

(b) **Radiation Degradation** - There are a number of reviews on the effects of radiation on polymer properties (Phillips 1988, Charlesby 1960). An extremely brief summary will be given here. The effects of  $\gamma$ -rays, neutrons and  $\beta$ -rays are essentially equivalent when their different penetrating powers are considered.  $\beta$ -rays (electrons) penetrate about a millimeter into a polymer, whereas  $\gamma$ -rays and neutrons penetrate much further.  $\alpha$ -rays (helium nuclei) penetrate only micrometers hence are only involved with very near surface damage.

The basic mechanical short term properties of a typical polymer start to change at a total radiation dose of between  $10^6$  and  $10^7$  rads (Phillips 1988). A rad is equivalent to 100 ergs of absorbed energy per gram of material. For reference purposes, the lethal dose of radiation to a human is about 100 to 200 rads. Therefore it would appear that if a geomembrane is containing low level nuclear waste of even lower radiation than the lethal human dose, the time before significant damage occurs to its short term mechanical properties will be quite long indeed. Other, more subtle changes may occur. For example, even very small amounts of local surface damage in a semi-crystalline geomembrane might cause a serious reduction in the stress crack resistance of the material. The effects of radiation on the additives may be a more severe problem than the effect on the polymer itself. It is possible that after a certain irradiation the material will be more susceptible to other degradation processes.

While no test protocol exists for evaluation, some form of incubation test method can be used with suitable modifications. Wyatt and Fansworth (1990) have evaluated a number of different geomembranes in simulated short-term tests in a high pH ( $\approx 14$  weight percent NaOH) inorganic solution at  $90^\circ\text{C}$  and subjected them to radiation doses up to  $39 \times 10^6$  rad. It was found that only

(d) Degradation by Swelling - One indication of a geomembrane's durability is the amount of swelling that occurs due to liquid absorption. It should be emphasized that swelling per se does not necessarily mean chain scission nor a failed system. It is, however, a bit disconcerting, and usually results in a change of physical and mechanical properties, at least on a temporary basis.

The test for water absorption, which can be modified for any liquid, is given in ASTM D570. The test is directed at a quantitative determination of the amount of water absorbed, but it is also used as a quality control test on the uniformity of the finished product. The test procedure cautions that the liquid absorption may be significantly different through the edge or through the surface, particularly with laminated products. (This fact alone suggests that in seaming of laminated geomembranes, the upper overlap must be protected against moisture uptake.) Test specimens of 75 by 25 mm are used and immersed in a number of possible ways:

- For 2 hr., 24 hr., or 2 weeks of constant immersion in 23°C water.
- Under cyclic (repeated) immersion.
- For 0.5 hr. or 2 hr. of constant immersion in 50°C water.
- For 0.5 hr. or 2 hr. of constant immersion in boiling water.

The resulting test data are reported as the percentage increase in weight using deionized and distilled water. Some typical values for commonly used geomembranes are as follows (Haxo, Nelson and Miedema 1985):

- PVC - 3 to 4%
- CPE - 1 to 4%
- CSPE - 1 to 5%
- HDPE - negligible
- VLDPE - not evaluated

Swelling due to other liquids is mentioned in the reference cited.

(e) Degradation by Extraction - Some polymers exhibit degradation by the long-term extraction of one or more components of the compound from the polymeric material. These are usually polymers which have been compounded with the use of plasticizers and/or fillers. The as-formulated and compounded mixture of such polymers is very intricate and the bonding mechanism is very complex. When extraction of plasticizers does occur, a sticky surface on the geomembrane results with the remaining

structure showing signs of increased modulus and strength, and a lowering of the elongation at failure, i.e. the material becomes progressively brittle (Doyle and Baker 1989). The long term behavior, however, is unknown. It is also possible that anti-degradant components within the polymer may be extracted and leach out to the surface. This might indicate that the remaining polymer is somewhat more sensitive to long-term degradation.

(f) Degradation by Delamination - For geomembranes which are manufactured by calendaring or spread coating, delamination is a possibility. It is usually observed when liquid enters into the edge of the geomembrane and is drawn into the interface by capillary tension. This can occur between geomembrane plies, between reinforcing scrim and one of the plies, or between the geomembrane coating of a fabric substrate as in spread coated geomembranes. When it occurs, the individual components are separated and composite action is lost. This type of wicking action has been problematic in the past, but current manufacturing methods and proper CQC/CQA in field operations have almost eliminated the situation.

(g) Oxidation Degradation - Whenever a free radical is created, e.g., on a carbon atom in the polyethylene chain, oxygen can create large scale degradation. The oxygen combines with the free radical to form a hydroperoxy radical, which is passed around within the molecular structure. It eventually reacts with another polymer chain creating a new free radical causing chain scission. The reaction generally accelerates once it is triggered as shown in the following equations.

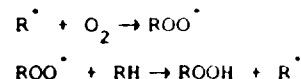

where

- $R^{\cdot}$  - free radical
- $ROO^{\cdot}$  - hydroperoxy free radical
- RH - polymer chain
- ROOH - oxidized polymer chain

Anti-oxidation additives are added to the compound to scavenge these free radicals in order to halt, or at least to interfere with, the process. These additives, or stabilizers, are specific to each type of resin. This area is very sophisticated and quite advanced with all resin manufacturers being involved in a meaningful and positive way. The specific anti-oxidants are usually proprietary. Removal of oxygen from the geomembrane's

surface, of course, eliminates the concern. Thus once placed and covered with waste, or liquid, degradation by oxidation should be greatly retarded. Conversely, exposed geomembranes, or those covered by nonsaturated soil, will be susceptible to the phenomenon.

(h) Biological Degradation - Within the various plant forms of biological life, i.e., bacteria, actinomycetes, fungi and algae, polymer degradation is essentially impossible due to the high molecular weight of the common resins used in geomembranes. In order for such degradation to occur the chain ends must be accessible and this is highly unlikely for molecular weights greater than 1000, let alone 10,000 to 30,000 which is common for geomembrane resins. Biological degradation might be possible for plasticizers or additives compounded with the resin, but information is not authoritative on this subject.

Within the higher forms of biological life, i.e., protozoa, spiders, insects, moles, rats and small mammals, polymers do not contain food and thus are unlikely to be consumed. It is possible, however, that an animal may try to penetrate the geomembrane for access to the opposite side. Here hardness of the predator's teeth enamel versus the geomembrane's hardness is the key comparison. While such events are possible, authoritative information on geomembranes being penetrated in this manner is not known to the authors.

#### Synergistic Effects

While not degradation mechanisms within, and of, themselves, there are several phenomena which can readily work in conjunction with the previously discussed items. They generally have the effect of accelerating the specific degradation process and thus are called "synergistic effects". At the outset it should be noted, however, that the quantification of these effects is very complicated and the data base is very weak in this regard.

(a) Elevated Temperatures - Whenever the temperature at the surface of, or within, the geomembrane is increased, the mobility of the polymer (and all of its other ingredients) is increased and degradation is usually accelerated. Of the different degradation mechanisms mentioned earlier, this is the case for all of them with the possible exception of biological degradation, which was seen to be of negligible significance. Clearly, elevated temperatures accelerate ultraviolet degradation and this phenomenon has perhaps the largest data base. Thus extreme conservatism is usually taken when testing

for ultraviolet degradation. As mentioned earlier, chemical resistance incubation is usually done at an elevated temperature of 50°C for comparison to the 23°C "standard" temperature. Invariably, the higher temperature produces results having greater changes than the lower temperature. There is an upper limit for such temperature testing, however, and that value is based upon polymer modification not representative of realistic behavior. Its value is undoubtedly resin dependent but largely unknown.

For geomembranes placed in the field, high temperatures can generally be avoided by covering them with soil, liquid or another material. Thus the buried environment greatly reduces temperatures in most geomembrane applications. Notable exceptions are surface impoundment and canal liners (above the liquid surface) and for floating covers. For all of these cases simulated testing is absolutely necessary.

(b) Applied Stresses - Invariably, the testing for geomembrane degradation is done on unstressed laboratory samples. Yet, at the very least, the geomembrane will have compressive stresses imposed, and quite possibly tensile stresses as well. What these stresses do to the degradation of the geomembrane as compared to testing in isolation is quite unknown. The reason for this lack of data is obvious. The cost of experimentation at elevated temperatures is very high in itself and to stress the geomembrane in some simulated form of biaxial stress would generally be cost prohibitive. Yet, some experimentation with stressed geomembranes should be initiated, at least to note the severity of the effect.

(c) Long Exposure - Long exposure includes a multiplicity of effects such as ultraviolet, extraction, oxidation, etc., which can result in synergistic effects beyond each of the previously discussed phenomenon taken individually. For materials as inert as polyethylene, for example, years of exposure at ambient temperature show no indication of any change of properties. For other polymers some changes in surface texture or even in macroscopic properties might occur, but their influence on the geomembrane's behavior is not clear.

The major authoritative data base on long-term aging is available from Matrecon, Inc., (1988), but the steady development of new polymers and compounds makes the situation elusive to say the least. It should be mentioned that a number of landfill owners are beginning to place geomembrane samples (coupons) in retrieveable locations for annual exhuming and evaluation. Such studies will eventually be helpful in assessing actual

degradation and aging although the coupons are rarely, if ever, in a stressed condition.

#### Accelerated Testing Methods

Clearly, the long time frames involved in evaluating individual degradation mechanisms at field related temperatures, compounded by synergistic effects, are not providing answers regarding geomembrane behavior fast enough for the decision making processes of today. Thus accelerated testing, either by high stress, elevated temperatures and/or aggressive liquids, is very compelling. Before reviewing these procedures, however, it must be clearly recognized that one is assuming that the high stress, elevated temperature or aggressive liquids used actually simulates extended lifetimes... an assumption which is not readily substantiated. Thus it might be that the test procedures to be described here actually form lower-bound conclusions in predicting degradation, i.e., the results may be minimum values but that is not known with any degree of certainty.

B.9 (a) Stress Limit Testing - Focusing almost exclusively on HDPE pipe for natural gas transmission, the Gas Research Institute, the Plastic Pipe Institute and the American Gas Association are all very active in various aspects of plastic pipe research and development. The three above-mentioned organizations, together with Battelle Columbus Laboratories sponsor the Plastic Fuel Gas Symposia which are held on a biennial basis and the resulting Proceedings contain many interesting papers. Stress limit testing in the plastic pipe area has proceeded to a point where there are generally accepted testing methods and standards. ASTM D1598 describes a standard experimental procedure and ASTM D2837 gives guidance on the interpretation of the results of the D1598 test method.

In ASTM D1598, long pieces of un-notched pipe are tightly capped and placed in a constant temperature environment. Room temperature of 23°C is usually used. The pipes are placed under various internal pressures which mobilize different values of hoop stress in the pipe walls, and the pipes are monitored until failure occurs. This is indicated by a sudden loss of pressure. Then the values of hoop stress are plotted versus failure times on a log-log scale, see Figure 2. If the plot is reasonably linear, a straight line is extrapolated to the desired, or design, lifetime which is often 10<sup>5</sup> hours or 11.4 years. The stress at this failure time multiplied by an appropriate factor is called the hydrostatic design basis stress. While of interest for pipelines, the stress state of geomembranes is essentially unknown and is

extremely difficult to model. Thus the technique is not of direct value for geomembrane design. It leads, however, to the next method.

(b) Rate Process Method (RPM) for Pipes - Research at the Gas Institute of The Netherlands (Wolters 1987) uses the method of pipe aging that is most prevalent in Europe. It is also an International Standards Organization (ISO) tentative standard currently in committee. Note that other plastic pipe research institutes also are involved in this type of research. The experiments are again performed using long pieces of un-notched pipe which are tightly capped, but now they are placed in various constant temperature environments. So as to accelerate the process, elevated temperature baths up to 80°C are used. Different pressures are put in the pipes at each temperature so that hoop stress occurs in the pipe walls. The pipes are monitored until failure occurs, resulting in sudden loss of pressure. Two distinct types of failures are found; ductile and brittle. The failure times corresponding to each applied pressure are recorded. A response curve is presented by plotting hoop stress against failure time on a log-log scale.

The rate process method (RPM) is then used to predict a failure curve at some temperature other than those tested, i.e., at a lower (field related) temperature than was evaluated in the high temperature tests. This method is based on an absolute reaction rate theory as developed by Tobolsky and Eyring (1943) for viscoelastic phenomenon. Coleman (1956) has applied it to explain the failure of polymeric fibers. The relationship between failure time and stress is expressed in the form as follows:

$$\log t_f = A_0 T^{-1} + A_1 T^{-1} \sigma \quad (1)$$

where

$t_f$  = time to failure  
 $T$  = temperature  
 $\sigma$  = tensile stress on the fiber  
 $A_0$  and  $A_1$  = constants

Bragaw (1983) has revised the above model on polymeric fibers and found three additional equations which yield reasonable correlation to the failure data of HDPE pipe. These three equations are as follows:

$$\log t_f = A_0 + A_1 T^{-1} + A_2 T^{-1} P \quad (2)$$

$$\log t_f = A_0 + A_1 T^{-1} + A_2 \log P \quad (3)$$

$$\log t_f = A_0 + A_1 T^{-1} + A_2 T^{-1} \log P \quad (4)$$

where

P = internal pipe pressure proportional to the hoop stress in the pipe

The application of RPM requires a minimum of two experimental failure curves at different elevated temperatures generally above 40°C. The equation which yields the best correlation to these curves is then used in the prediction procedure for a response curve at a field related temperature e.g., 10°C to 25°C. Two separate extrapolations are required, one for the ductile response and one for the brittle response. Three representative points are chosen on the ductile regions of the two experimental curves. One curve will be selected for two points, and the other, the remaining point. This data is substituted into the chosen equation, i.e., Equation 1, 2 or 3, to obtain the prediction equation for the ductile response of the curve at the desired (lower) temperature. The process is now repeated for the predicted brittle response curve at the same desired temperature. The intersection of these two lines defines the transition time.

Figure 3 shows two experimental failure curves which were conducted at temperatures of 80°C and 60°C along with the predicted curve at 20°C. The intersection of the linear portions of the 20°C curve represents the anticipated time for transition in the HDPE pipe from a ductile to a brittle behavior of the material. For pipe design, however, the intersection of the desired service lifetime, say 50 years, with the brittle curve is the focal point. A factor of safety is then placed on this value, e.g., note that it is lowered to 6.5 MPa in Figure 3. This value of stress is used as a limiting value for internal pressure in the pipe.

(c) Rate Process Method (RPM) for Geomembranes - A similar RPM method to that just described for HDPE pipes can be applied to HDPE geomembranes. The major difference is the method of stressing the material. The geomembrane tests are performed using a notched constant load test (NCLT). In this test, dumbbell shaped specimens are taken from the geomembrane sheet. A notch is introduced on one of the surfaces; the notch depth being 20% of the thickness of the sheet. The full description of the

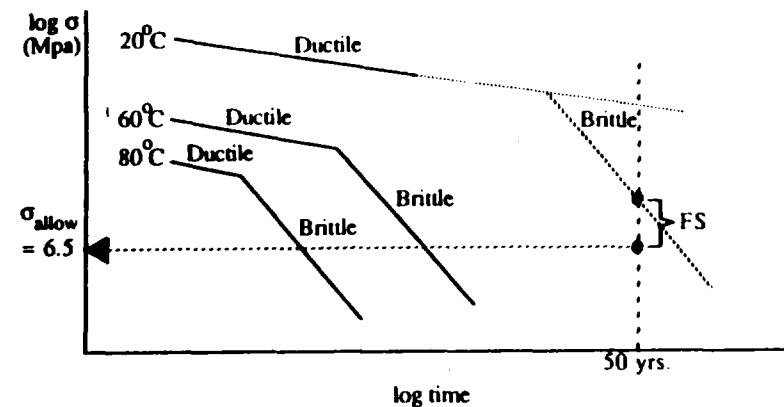

Figure 3 - Burst Test Data for MDPE Pipe. The Intersection of the Ductile Portion of the 20°C Line and 50 Years Has Been Lowered to 6.5 MPa by Multiplication with the Appropriate Factor of Safety. (From Ref. 14)

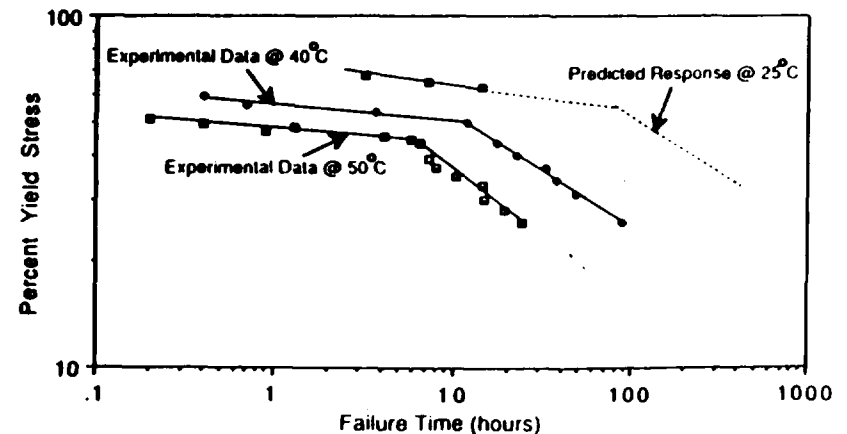

Figure 4 - Notched Constant Load Tests (NCLT) on HDPE Geomembrane Samples Immersed in 10% Igepal/90% Tap Water Solution.

notching process is described by Halse, et al. (1990). Tensile loads varying from 30% to 70% of the yield stress of the sheet, are applied to the notched specimens. The tests are performed in elevated constant temperature environments (usually from 40°C to 80°C) and in a surface active wetting agent. Often a 10% Igepal and 90% tap water is used. The data is presented by plotting percent yield stress against failure time on a log-log scale. Figure 4 shows typical experimental curves at 50°C and 40°C which are seen to be very similar to the behavior of HDPE pipe, recall Figure 3. Here distinct ductile and brittle regions can be seen along with a clearly defined transition time.

In order to use these elevated temperature curves to obtain the transition time for a realistic temperature of a geomembrane beneath solid waste or liquid impoundments, e.g., at 25°C, only Equations 3 or 4 can be used due to the data being plotted on a log-log scale. The following is a step-by-step procedure of how the experimental data is used in this regard.

Step. 1 Determine the best fit equation among Equations 3 or 4. We will select Equation 3 which has been found to show the best fit for both the ductile and brittle data.

Step. 2 Obtain the equation for the ductile region of the 25°C curve. To predict the ductile region of the 25°C curve, two data points were chosen from the ductile region of the 50°C curve and one from the 40°C curve. The details of their values are as follows:

Point 1:  $T_1 = 323$  °K;  $P_1 = 48\% = 9.72$  MPa;

$t_1 = 1$  h

Point 2:  $T_2 = 313$  °K;  $P_2 = 52\% = 10.53$  MPa;

$t_2 = 5$  h

Point 3:  $T_3 = 313$  °K;  $P_3 = 56\% = 11.34$  MPa;

$t_3 = 1$  h

Note that the calculations are in degrees Kelvin which is degrees Centigrade plus 273 degrees. By substituting the above three sets of data into Equation (3), and solving the resulting three simultaneous equations, three constants are obtained and are listed below:

$$A_0 = -37.18, \quad A_1 = 18774, \quad \text{and} \quad A_2 = -21.2$$

By substituting these constants back into

Equation (3) the following equation results for predicting the ductile portion of the curve at any temperature.

$$\log t = -87.18 + 18774/T - 21.2 \log P \quad (5)$$

Step 3. Obtain the equation for the brittle region of the 25°C curve. For the brittle region, two data points were chosen from the brittle region of the 50°C curve and one point from the 40°C curve. The details of their values are as follows:

Point 1:  $T_1 = 323$  °K;  $P_1 = 37\% = 7.50$  MPa;

$t_1 = 10$  h

Point 2:  $T_2 = 323$  °K;  $P_2 = 28\% = 5.67$  MPa;

$t_2 = 20$  h

Point 3:  $T_3 = 313$  °K;  $P_3 = 37\% = 7.50$  MPa;

$t_3 = 30$  h

The resulting three constants obtained by simultaneous solution of the resulting three forms of Equation 3 are listed below:

$$A_0 = -11.8, \quad A_1 = 4853, \quad \text{and} \quad A_2 = -2.5$$

Therefore, the equation for predicting the brittle portion of the curve at any temperature is as follows:

$$\log t = -11.8 + 4853/T - 2.5 \log P \quad (6)$$

Step 4. Use Equations (5) and (6) to obtain the predicted response curves at the desired temperature. The ductile behavior from Equation (5) and the brittle behavior from Equation (6) at the specific temperature of 25°C was used to plot the desired curves at 25°C in Figure 4.

Step 5. Intersect the two prediction curves for the ductile-to-brittle transition time. As seen in Figure 4 this intersection produces a transition time for the 25°C temperature response of 60 hours. Note that the ductile-to-brittle transition time is increased over ten fold (from 6 to 70 hours) by decreasing 25 degrees in temperature. It should also be noted that this curve represents the behavior of the geomembrane in 10% Igepal solution. The performance of the same geomembrane will

probably be very different in other environments, such as in leachate or water.

(d) Elevated Temperature and Arrhenius Modeling - Using an experimental chamber as shown in Figure 5, Mitchell and Spanner (1985) have superimposed compressive stress, chemical exposure, elevated temperature and long testing time into one experimental device. For their particular tests, three duplicate chambers were operated at 18°C, 48°C and 78°C respectively. At the end of the arbitrarily designated test period (in the example to be described it was 18 weeks), the geomembrane samples were removed. Mechanical tests and chemical analyses were performed on these incubated samples to monitor if any changes in the various properties of the geomembranes occurred.

The mechanical tests included the following:

- Tensile Strength and Elongation
- Yield Strength and Elongation
- Stress Cracking Behavior

The chemical analyses included the following:

- Differential scanning calorimetry (DSC); for measuring crystallinity and oxidation induction time (OIT)
- Infra-red spectrometry (IR); for measuring concentration of carbonyl groups
- Gel permeation chromatography (GPC); for measuring the molecular weight and molecular weight distribution

If there were changes in any of the above properties; for example, in the concentration of the carbonyl group, the reaction rate (K) was obtained for each experimental test temperature (T). These values were now used with the Arrhenius equation which is as follows (American National Standard 1986):

$$K = Ae^{-E/RT} \quad (4)$$

where

- K = reaction rate for the process considered
- A = a constant for the process considered
- E = reaction activation energy for the process considered
- T = temperature ( $^{\circ}\text{K} = ^{\circ}\text{C} + 273$ )
- R = gas constant (8.314 J/mol- $^{\circ}\text{K}$ )

By plotting "ln K" against "1/T", a straight line should be obtained, see Figure 6. The slope of this line is "-E/R" for the particular property change being

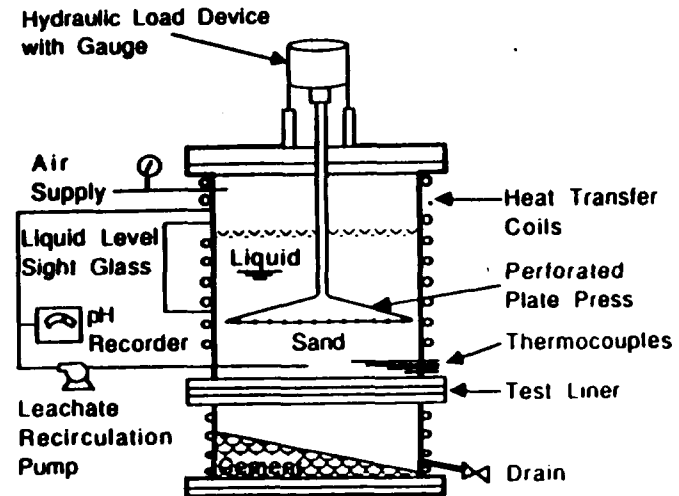

Figure 5 - Schematic of Accelerated Aging Column (after Mitchell and Spanner)

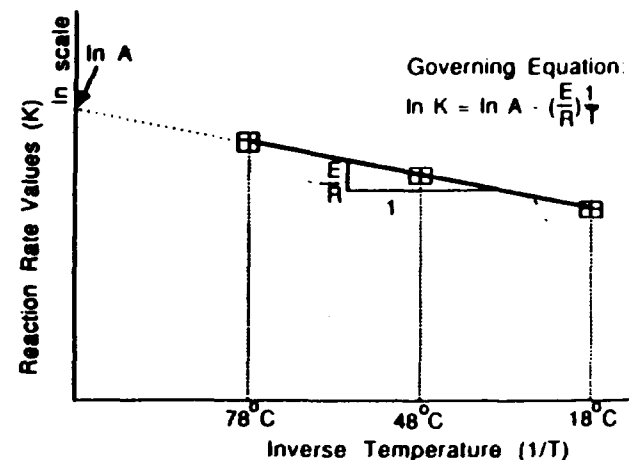

Figure 6 - Graphical Method of Plotting Reaction Rate Values for Change in a Specific Geomembrane Property.

monitored. The constant "A" can also be identified but it drops out of the equation when comparing the responses at two different temperatures.

For example, Turi (1981) found that the activation energy (E) of polyethylene is 109,000 J/mol. This is the energy requirement for an atom to change its position. If we use this value in Mitchell and Spanner's tests, then the degradation that occurs between the two tests at temperatures of 18°C and 78°C is determined as follows:

$$\frac{r_{78} + 273}{r_{18} + 273} = e^{-\frac{(109,000)}{8.314} \left[ \frac{1}{351} - \frac{1}{291} \right]}$$

$$= 2254$$

Hence, for their particular process occurring in 18 weeks at 78°C it would take 2264 times 18 weeks, or 784 years, to occur at 18°C.

B-13

(e) Hoechst Multiparameter Approach - The Hoechst research laboratory in West Germany has been active in long term testing of HDPE pipe since the 1950's. Recently they have been applying their expertise and experience to the long term behavior of HDPE geomembranes (Kork, et al. 1987). Note, however, that there are major differences between pipe and sheet. The stress state in pressurized pipe is well known, whereas the stress state in the geomembranes in the field is not nearly as well known. Furthermore, the pipe is under a constant stress state, whereas stress relaxation can occur in geomembranes. If these two differences in the state of stress between pipe and sheet can be resolved, then the tremendous wealth of data obtained in over 30 years of pipeline testing can be carried over to the geomembrane area.

The Hoechst group has considered geomembranes for the case of local subsidence under the liner and the mobilization of out-of-plane deformation of the sheet into an multi-axial stress state. Thus their model for sheet stresses is biaxial stress. (In the usual pressurized pipe, the radial stress is twice the value of the longitudinal stress. Hence the isotropic biaxial stress state in a normal pipe testing experiment was achieved by putting the pipes under an additional longitudinal stress. It was found that the lifetimes in these tests were the same as in normal pressure burst testing. Hence if biaxial stress relaxation could be accounted for, a viable long term testing technique could very well be developed for sheet from modified pipe testing. This of course assumes that the different manufacturing and processing of pipe and sheet produce

essentially the same material properties. (This may not be completely the case.) The Hoechst long term testing for geomembrane "sheet" thus consists of the following procedure:

- (1) Modified burst testing of pipe (of the same material as the sheet), with additional longitudinal stress to produce an isotropic, biaxial stress state. Their tests make note that the site-specific liquid should be used.
- (2) Assume a given subsidence strain versus time profile.
- (3) Measurement of stress relaxation curves in sheets which have been stressed biaxially, at strain values encountered in field.
- (4) Use steps (2) and (3) to predict the stress as a function of time.
- (5) See how these maximum stresses compare with the stress-lifetime curves determined in the normal constant stress-lifetime pipe measurements of Step (1). The constant stress-lifetime curves are modified (as in the normal pipe testing) to accommodate the effects of various chemicals and even for seams.
- (6) If linear accumulation of degradation is assumed, then the variable stress curves can be used to predict failure from the constant stress-lifetime curves.

The steps (1)-(5) have been performed by Kork, et al. (1987). The approach should certainly be considered seriously. One of the main impediments to its viability would seem to be that if one produces pipe, the final product may have different material properties than sheet. For example, the residual stresses could be quite different. Other work of a related nature can be found in Hessel and John (1987) and Gaube, et al. (1976).

#### Summary and Conclusions

This rather lengthy treatise on durability and aging has attempted to give insight into long-term performance of geomembranes by itemizing those mechanisms which can degrade the polymer resin and/or compound. Table 3 gives a summary of the individual degradation mechanisms that were discussed. All of them, taken individually, are possible to evaluate and/or quantify. In addition, some suggestions as to preventative measures are offered.

Table 3 - Degradation Phenomena In Geomembranes (from a Geosynthetic Engineering Perspective)

Degradation Classification	Degradation Mechanism	Initial Change in Material		Subsequent Change in Material		Preventative Measure
		Laboratory <sup>(1)</sup>	Field <sup>(2)</sup>	Laboratory <sup>(3)</sup>	Field <sup>(4)</sup>	
Ultraviolet	<ul style="list-style-type: none"> <li>• chain scission</li> <li>• bond breaking</li> </ul>	<ul style="list-style-type: none"> <li>• mol. wt.</li> <li>• stress crack resist.</li> </ul>	<ul style="list-style-type: none"> <li>• color</li> <li>• crazing</li> </ul>	<ul style="list-style-type: none"> <li>• elongation</li> <li>• modulus</li> <li>• strength</li> </ul>	<ul style="list-style-type: none"> <li>• color</li> <li>• cracking</li> </ul>	<ul style="list-style-type: none"> <li>• screening agent</li> <li>• anti-degradant</li> <li>• cover geomembrane</li> </ul>
Radiation	<ul style="list-style-type: none"> <li>• chain scission</li> </ul>	<ul style="list-style-type: none"> <li>• mol. wt.</li> <li>• stress crack resist.</li> </ul>	<ul style="list-style-type: none"> <li>• color</li> <li>• crazing</li> </ul>	<ul style="list-style-type: none"> <li>• elongation</li> <li>• modulus</li> <li>• strength</li> </ul>	<ul style="list-style-type: none"> <li>• color</li> <li>• cracking</li> </ul>	<ul style="list-style-type: none"> <li>• cover for <math>\beta</math> and <math>\alpha</math>-rays</li> <li>• shield for neutrons</li> <li>• reduce dosage for <math>\gamma</math> rays</li> </ul>
Chemical	<ul style="list-style-type: none"> <li>• reaction with structure</li> <li>• reaction with additives</li> </ul>	<ul style="list-style-type: none"> <li>• carbonyl index</li> <li>• IR</li> <li>• mol. wt.</li> </ul>	<ul style="list-style-type: none"> <li>• texture</li> <li>• color</li> <li>• crazing</li> <li>• TGA</li> </ul>	<ul style="list-style-type: none"> <li>• elongation</li> <li>• modulus</li> <li>• strength</li> </ul>	<ul style="list-style-type: none"> <li>• texture</li> <li>• cracking</li> <li>• reactions</li> </ul>	<ul style="list-style-type: none"> <li>• proper resin</li> <li>• proper additives</li> </ul>
Swelling	<ul style="list-style-type: none"> <li>• liquid absorption</li> </ul>	<ul style="list-style-type: none"> <li>• TGA</li> </ul>	<ul style="list-style-type: none"> <li>• thickness</li> <li>• color</li> <li>• texture</li> </ul>	<ul style="list-style-type: none"> <li>• thickness</li> <li>• modulus</li> <li>• strength</li> </ul>	<ul style="list-style-type: none"> <li>• thickness</li> <li>• softness</li> </ul>	<ul style="list-style-type: none"> <li>• proper resin</li> <li>• proper manufacturing</li> </ul>
Extraction	<ul style="list-style-type: none"> <li>• additive expulsion</li> </ul>	<ul style="list-style-type: none"> <li>• TGA</li> <li>• IR</li> </ul>	<ul style="list-style-type: none"> <li>• texture</li> <li>• color</li> <li>• thickness</li> </ul>	<ul style="list-style-type: none"> <li>• elongation</li> <li>• modulus</li> <li>• thickness</li> </ul>	<ul style="list-style-type: none"> <li>• texture</li> <li>• color</li> </ul>	<ul style="list-style-type: none"> <li>• proper compounds</li> <li>• proper manufacturing</li> </ul>

Table 3 - Continued

Degradation Classification	Degradation Mechanism	Initial Change in Material		Subsequent Change in Material		Preventative Measure
		Laboratory <sup>(1)</sup>	Field <sup>(2)</sup>	Laboratory <sup>(3)</sup>	Field <sup>(4)</sup>	
Delamination	<ul style="list-style-type: none"> <li>• adhesion loss</li> </ul>	<ul style="list-style-type: none"> <li>• thickness</li> <li>• edge effects</li> </ul>	<ul style="list-style-type: none"> <li>• thickness</li> <li>• edge effects</li> </ul>	<ul style="list-style-type: none"> <li>• thickness</li> <li>• ply adhesion</li> </ul>	<ul style="list-style-type: none"> <li>• layer separation</li> <li>• thickness</li> </ul>	<ul style="list-style-type: none"> <li>• proper manufacturing</li> <li>• protect geomembrane edges</li> </ul>
Oxidation	<ul style="list-style-type: none"> <li>• reaction with structure</li> </ul>	<ul style="list-style-type: none"> <li>• IR</li> <li>• carbonyl index</li> <li>• OIT</li> </ul>	<ul style="list-style-type: none"> <li>• color</li> <li>• crazing</li> </ul>	<ul style="list-style-type: none"> <li>• elongation</li> <li>• modulus</li> <li>• strength</li> </ul>	<ul style="list-style-type: none"> <li>• color</li> <li>• cracking</li> </ul>	<ul style="list-style-type: none"> <li>• anti-oxidant</li> <li>• cover with soil</li> <li>• cover with liquid</li> </ul>
Biological	<ul style="list-style-type: none"> <li>• reactions with additives</li> </ul>	<ul style="list-style-type: none"> <li>• mol. wt.</li> <li>• carbonyl index</li> <li>• IR</li> </ul>	<ul style="list-style-type: none"> <li>• texture</li> <li>• surface film</li> </ul>	<ul style="list-style-type: none"> <li>• elongation</li> <li>• modulus</li> <li>• strength</li> </ul>	<ul style="list-style-type: none"> <li>• texture</li> <li>• surface layer</li> <li>• cracking</li> </ul>	<ul style="list-style-type: none"> <li>• avoid sensitive additives</li> <li>• biocide</li> </ul>

Notes:

- (1) Initial laboratory changes are generally sensed by chemical fingerprinting methods: mol. wt. = molecular weight, IR = infrared spectroscopy, TGA = thermal geometric analysis, OIT = oxidation induction time
- (2) Initial field changes are generally sensed on a qualitative basis.
- (3) Subsequent laboratory changes can be sensed by numerous physical and mechanical tests. Listed in the table are those considered to be the most sensitive parameters.
- (4) Subsequent field changes are a continuation of the initial changes until physical and mechanical properties being to visually change.

Also described in the paper were various synergistic effects which greatly complicate the above mechanisms when acting concurrently. Items such as elevated temperature, biaxial or triaxial stress and long exposure time are very difficult to model accurately. Nevertheless, much laboratory modeling had been done, although most has been by the plastic pipe industry. This is almost exclusively on polyethylene pipe and the technology transfer to polyethylene geomembranes is certainly very valuable. Many of the techniques are being evaluated for long-term geomembrane performance; for example, ductile-to-brittle transition time along with Arrhenius modeling. Other types of geomembranes appear to be in need of long-term simulation testing as was discussed in various facets of the paper.

In conclusion, it is felt that case histories (both positive and negative) give the best insight into the field behavior of geomembrane lined facilities at this point in time. Test strips which are exhumed annually and tested, versus the original material are extremely valuable. They can be placed along the edge of the facility or within sump areas for easy removal. Field failures are also very important to analyze for aiding and prompting in the modification of existing polymer formulations and perhaps changing the basic resins themselves. Lastly, long term laboratory tests under simulated conditions should be undertaken. Simulated stress tests under elevated temperature testing and Arrhenius modeling is very intriguing in this regard as is some type of modification of the Hoechst procedures. Answers to the important question of "how long will they last" may never be known unless the effort begins as soon as possible.

#### References

- , U. S. Federal Register, Regulations on Liner Systems, July 26, 1982.
- , U. S. EPA Method 9090, Compatibility Test for Wastes and Membrane Liners, in Test Methods for Evaluating Solid Waste Physical/Chemical Methods, SW-846, 2nd Edition, 1984.
- , U.S. EPA Computer Code on Flexible Membrane Liner Advisory Expert System (FLEX), Cincinnati, Ohio, 1987.
- , "Standard for Polymeric Materials - Long Term Property Evaluations," American National Standard, ANSI/UL 746B - 1986.
- Apse, J. I., "Polyethylene Resins for Geomembrane Applications," Durability and Aging of Geosynthetics, R. M. Koerner, Ed., Elsevier Appl. Sci. Publ. Ltd., 1989, pp. 159-176.

- Bragaw, G. G., "Service Rating of Polyethylene Piping Systems by the Rate Process Method," 8th Plastic Fuel Gas Pipe Symp., Nov. 1983.
- Charlesby, A., Atomic Radiation and Polymers, Oxford University Press, 1960.
- Chuck, R. T., "Largest Butyl Rubber Lined Reservoir," Civil Engineering, ASCE, May 1970, pp. 44-47.
- Coleman, B. D., "Application of the Theory of Absolute Reaction Rates to the Creep Failure of Polymeric Filaments," Jour. Polymer Science, Vol. 20, 1956, pp. 447-455.
- Doyle, R. A. and Baker, K. C., "Weathering Tests of Geomembranes," Durability and Aging of Geosynthetics, R. M. Koerner, Ed., Elsevier Appl. Sci. Publ. Ltd., 1989, pp. 152-158.
- Gamski, K., "Geomembranes: Classification, Uses and Performance," Jour. Geotex. and Geomemb., Elsevier Appl. Sci. Publ. Ltd., Vol. 1, 1984, pp. 85-117.
- Gaube, E., Diedrick, G. and Muller, W., "Pipes of Thermoplastics; Experience of 20 Years of Pipe Testing, Kunststoffe, Vol. 66, 1976, pp. 2-8.
- Geier, F. H. and Morrison, W. R., "Buried Asphalt Membrane Canal Lining," Research Report No. 12, A Water Resources Technical Publication, Bureau of Reclamation, Denver, Colorado, 1968.
- Grassie, N. and Scott, G., Polymer Degradation and Stabilization, Cambridge University Press, 1985.
- Halse, Y. H., Lord, A. E. Jr. and Koerner, R. M., "Ductile-to-Brittle Transition Time in Polyethylene Geomembrane Sheet," Symposium on Geosynthetic Testing for Waste Containment Applications, ASTM Spec. Tech. Publ., to appear in 1990.
- Häxo, H. E., Nelson, N. A. and Miedema, T. A., "Solubility Parameters for Predicting Membrane Waste Liquid Compatibility," Proc. EPA Conf. on Hazardous Waste, Cincinnati, OH, Apr. 1985, pp. 198-215.
- Hessel, J. and John, P., "Long Term Strength of Welded Joints in Polyethylene Sealing Sheets," Werkstofftechnik, Vol. 18, 1987, pp. 228-231.
- Kays, W. B., Construction of Linings for Reservoirs, Tanks and Pollution Control Facilities, 2nd Ed., J. Wiley and Sons, Inc., NY, 1988.
- Koerner, R. M., Designing with Geosynthetics, 2nd Ed., Prentice Hall Publ. Co., Englewood Cliffs, NJ, 1990.
- Kork, R., et. al., "Long Term Creep Resistance of Sheets of Polyethylene Geomembrane, Report TR-88-0054 from Hoechst A.G., Frankfurt, W. Germany, 1987.
- Matrecon, Inc., Lining of Waste Impoundment and Disposal Facilities, EPA/600/2-88.052, Sept., 1988.
- Mitchell, D. H. and Spanner, G. E., "Field Performance Assessment of Synthetic Liners for Uranium Tailings Ponds," Status Report, Battelle PNL, U.S. NRC, NUREG/CR-4023, PNL-5005, Jan., 1985.

Phillips, D. C., "Effects of Radiation on Polymers," *Materials Science and Technology*, Vol. 4, 1988, pp. 85-91.

Staff, C. E., "The Foundation and Growth of the Geomembrane Industry in the United States," *Intl. Conf. Proc. on Geomembranes*, Dever, Colorado, IFAI, 1984, pp. 5-8.

Tobolsky, A. and Eyring, H., "Mechanical Properties of Polymeric Materials," *Jour. Chem. Phys.*, Vol. 11, 1943, pp. 125-134.

Turi, A., Thermal Characterization of Polymeric Materials, Academic Press, 1981.

Van Zaten, R. V., Geotextiles and Geomembranes in Civil Engineering, A. A. Balkema Press, Rotterdam and Boston, 1986.

Whyatt, G. A. and Farnsworth, R. K., "The Effect of Radiation on the Properties of HDPE and PP Liners," *Symposium on Geosynthetic Testing for Waste Containment Applications*, ASTM Spec. Tech. Publ., to appear in 1990.

Wolters, M., "Prediction of Long-Term Strength of Plastic Pipe," *Proc. 10th Plastic Fuel Gas Symp.*, 1987, New Orleans, Amer. Gas Assoc. Publ.

B-16

**Acknowledgements**

The authors would like to express sincere appreciation to all of the sponsoring member organizations of the Geosynthetic Research Institute. A listing of the firms and their contact members is available from the authors. The Institute is focused on long term generic research in geosynthetics of the type described in this paper.

# WASTE CONTAINMENT SYSTEMS:

## Construction, Regulation, and Performance

Proceedings of a Symposium sponsored by the Committee on Soil Improvement and Geosynthetics and the Committee on Soil Properties of the Geotechnical Engineering Division, American Society of Civil Engineers in conjunction with the ASCE National Convention San Francisco, California November 6-7, 1990

**GEOTECHNICAL SPECIAL PUBLICATION NO. 26**

**Edited by Rudolph Bonaparte**



Published by the American Society of Civil Engineers  
345 East 47th Street  
New York, New York 10017-2398