

00070

VOLUME II
2 of 2

FINAL
REMEDIAL INVESTIGATION REPORT
CARDINGTON ROAD LANDFILL SITE
(Also known as Sanitary Landfill)
MORaine, OHIO

EPA Region 5 Records Ctr.



231059

**TABLE OF CONTENTS
(continued)**

**REMEDIAL INVESTIGATION REPORT
CARDINGTON ROAD LANDFILL SITE
MORaine, OHIO**

**VOLUME II
2 of 2**

APPENDICES

APPENDIX NO.

APPENDIX A	BORING LOGS AND WELL CONSTRUCTION DIAGRAMS - INTRUSIVE BORINGS
APPENDIX B	TEST BORING LOGS FOR PERIMETER MONITORING WELLS
APPENDIX C	PERIMETER MONITORING WELL CONSTRUCTION DIAGRAMS
APPENDIX D	QA/QC AND DATA SUFFICIENCY TECHNICAL MEMORANDUM
APPENDIX E	ANALYTICAL RESULTS FOR QA/QC SAMPLES (FIELD BLANKS, TRIP BLANKS, MATRIX SPIKES, MATRIX SPIKE DUPLICATES)
APPENDIX F	GEOTECHNICAL LABORATORY TEST RESULTS - LANDFILL SOIL COVER SAMPLES
APPENDIX G	HYDROLOGIC EVALUATION OF LANDFILL PERFORMANCE (HELP) MODEL SIMULATIONS
APPENDIX H	ON-SITE GAS VENT MODELING DESCRIPTION (bound separately with Risk Assessment)
APPENDIX I	CONCEPTUAL MODEL TO PREDICT FUTURE GROUND WATER CONCENTRATIONS BASED ON LEACHATE DATA

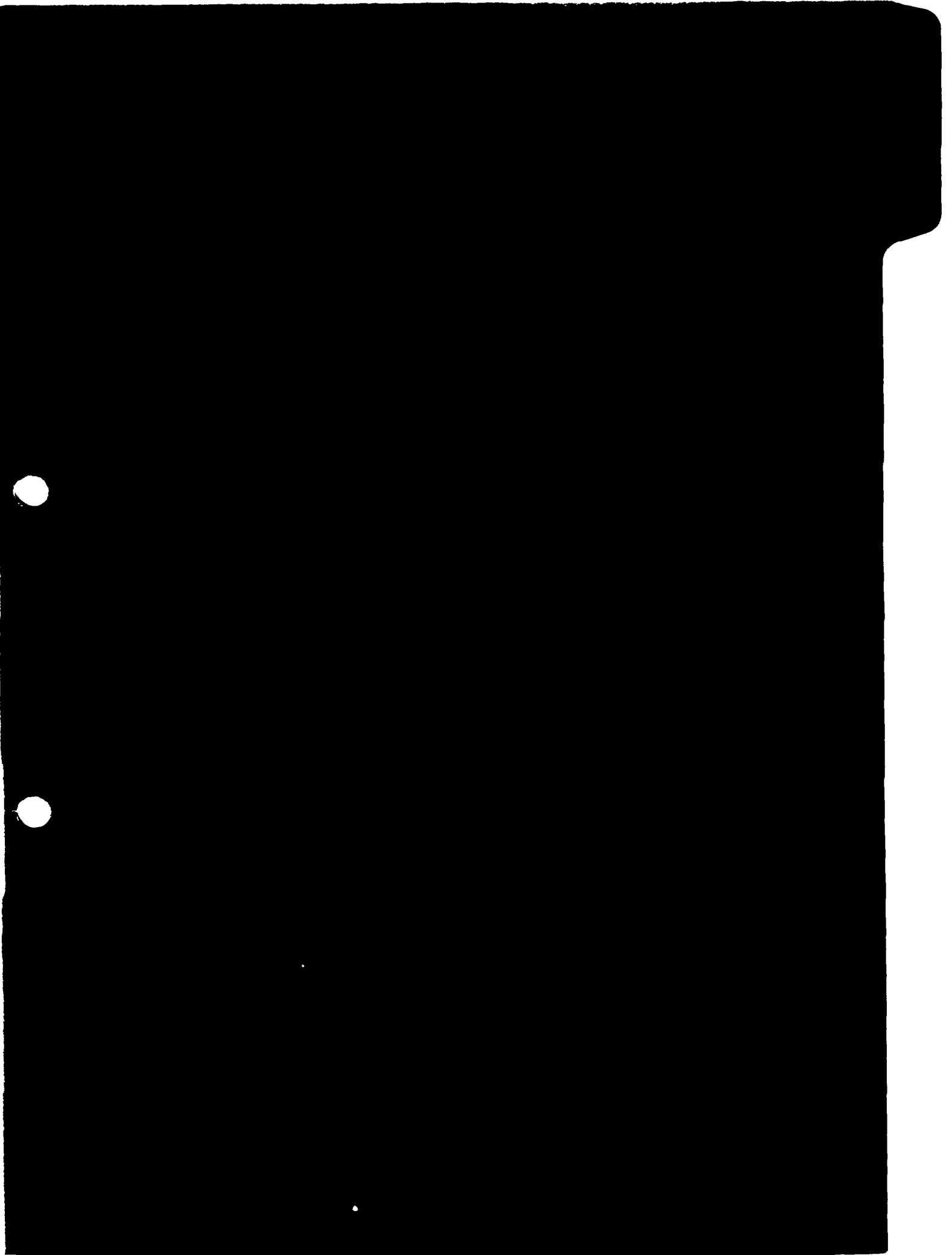

APPENDIX A

**BORING LOGS AND WELL CONSTRUCTION
DIAGRAMS - INTRUSIVE BORINGS**

SOIL DRILLING LOG

PROJECT:	<u>CRC</u>
SAMPLING DATE(S):	<u>11-1-90</u> START: <u>0800</u> FINISH: <u>1700</u>
SAMPLING METHOD:	_____
LOCATION:	<u>MORAINÉ, OHIO</u>

SAMPLED DEPTH (FEET)	SAMPLE IDENTIFICATION	RECOVERY (FEET)	BLOWS PER SIX INCHES	HNU READING (PPM)	SOIL DESCRIPTION, COLOR, TEXTURE, MOISTURE, ETC.
0				5.3	BROWN MEDIUM SAND
1'-2'					WASTE
5.0					BLACK STYROFOAM SHAPEN LIKE "MUSHROOM CAP" REFUSE
			@91-7.0		AND DARK GREY-BLACK SOIL.
10.0					
			@11'-3.1		
13.0				4.2	BLACK SILTY MATERIAL, WET
19.0				122	
26.0				178.0	DARK BROWN-BLACK WET SILTY MATERIAL; WOOD FRAGMENTS AND ORGANICS.
31.0				↓	hard material - offset augers
35.0				∅	
40.0	SS1	5"		∅	BROWN SILTY SANDY MATERIAL WITH CLAY MIXED WITH PLASTIC, WET.
42.0	SS2	1.5'		∅	SAA; WITH RED-ORANGE BRICK AND A LOT OF CLAY;
45.0		0		2.1	(NO SAMPLE) OBSTRUCTION ENCOUNTERED
48.0		0	@54'-2.4		(NO SAMPLE) NO RECOVERY



McLAREN/HART

LEACHATE WELL IB-1

PROJECT: CRC INTRUSIVE DRILLING

LOCATION: MORaine, OHIO

DRILLING METHOD: HSA

DATES OF COMPLETION: 11/01/90 - 11/02/90

DRILLING CONTRACTOR: BOWSER-MORNER

GEOLOGIST: HUNZEKER

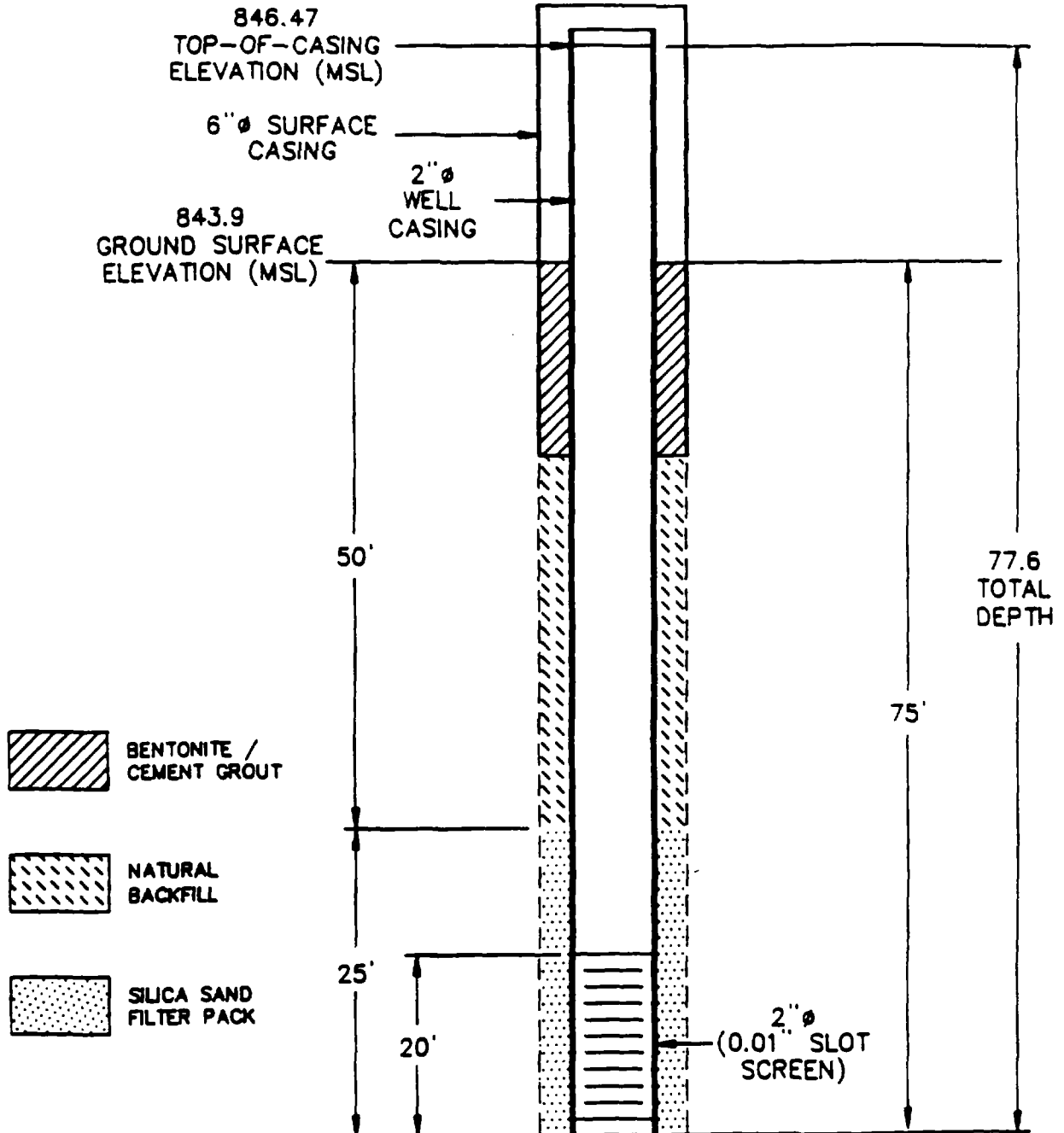

ALL DEPTHS ARE APPROXIMATE



SB Number IB-2
 Page: 1 of 2
 Sampler(s): _____

SOIL DRILLING LOG

PROJECT: CRC
 SAMPLING DATE(S): 11-2-90 / 11-3-90 START: _____ FINISH: _____
 SAMPLING METHOD: _____
 LOCATION: MORaine, OHIO

SAMPLED DEPTH (FEET)	SAMPLE IDENTIFICATION	RECOVERY (FEET)	BLOWS PER SIX INCHES	HMU READING (PPH)	SOIL DESCRIPTION, COLOR, TEXTURE, MOISTURE, ETC.
0					BROWN, DRY MEDIUM SAND AND GRAVEL
8.0					REFUSE: organic, styrofoam, aluminum
10.0					BROWN THIN CLAY LAYER; BLACK PLASTIC, ORGANICS, "MUSHROOM CAPS"
15.0					NO RECOVERY
17.0					"mushroom" styrofoam cap, plastic silty mat
23.0					WET, DK BROWN-BLACK, "MUSHROOMS" AND PLASTIC.
25.0					BLACK THICK SOUPY MATERIAL WITH PLASTIC.
30.0					"SAME AS ABOVE"
35.0					"SAME AS ABOVE"
40.0	SS1	1.5'		50.0	BLACK ASH-LIKE MATERIAL; ORGANICS; WOOD WITH SAND AND GRAVEL
50.0	SS2	1.2'		∅	REFUSE - BLACK SILTY MATERIAL; VERY LITTLE WASTE MATERIAL
55.0	SS3	1-2"		∅	REFUSAL; BLACK MOIST ^{SILTY} WOODY MATERIAL
60.0	SS4	3"		∅	BLACK, THICK SILTY MATERIAL
					BLACK-GREY WOODY MATERIAL IN A SILTY MATRIX



SB Number IB-2
 Page: 2 OF 2
 Sampler(s): _____

SOIL DRILLING LOG

PROJECT: CRC
 SAMPLING DATE(S): 11-2-90 / 11-3-90 START: _____ FINISH: _____
 SAMPLING METHOD: _____
 LOCATION: MURKIN, OHIO

SAMPLED DEPTH (FEET)	SAMPLE IDENTIFICATION	RECOVERY (FEET)	BLOWS PER SIX INCHES	HMW READING (PPM)	SOIL DESCRIPTION, COLOR, TEXTURE, MOISTURE, ETC.
65.0	SS5	5"		φ	BROWN MEDIUM-COARSE SAND, WELL-COMPACTED, WITH GRAVEL. BELIEVE TO BE NATIVE
67.0	SS6	4"		φ	GREYISH-BLACK MED.-COARSE SAND W/ VERY LITTLE GRAVEL.
69.0	SS7	1.0'		φ	LIGHT BROWN COARSE SAND, POORLY SORTED, COMPACT.
					EOB = 71.0'



McLAREN/HART

LEACHATE WELL

IB-2

PROJECT: CRC INTRUSIVE DRILLING

LOCATION: MORaine, OHIO

DRILLING METHOD: HSA

DATES OF COMPLETION: 11/02/90 - 11/03/90

DRILLING CONTRACTOR: BOWSER-MORNER

GEOLOGIST: HUNZEKER, FLEMING

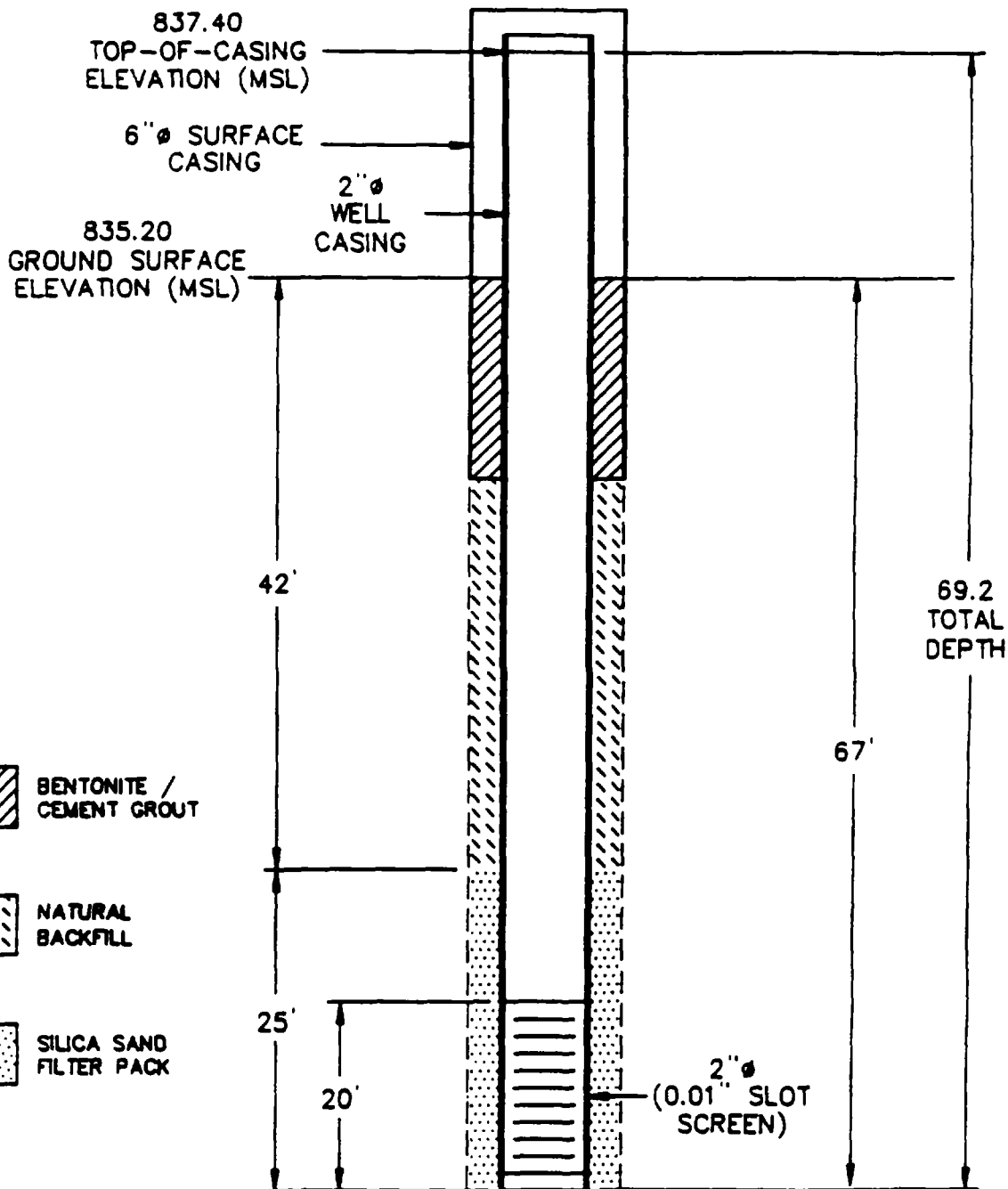

ALL DEPTHS ARE APPROXIMATE



SB Number IB-3
 Page: 10E1
 Sampler(s): _____

SOIL DRILLING LOG

PROJECT: CRC
 SAMPLING DATE(S): 10-29-90 START: _____ FINISH: _____
 SAMPLING METHOD: _____
 LOCATION: MORaine, Ohio

SAMPLED DEPTH (FEET)	SAMPLE IDENTIFICATION	RECOVERY (FEET)	BLOWS PER SIX INCHES	HMU READING (PPM)	SOIL DESCRIPTION, COLOR, TEXTURE, MOISTURE, ETC.
0					
5.0	8'9" WASTE			∅	BROWN SOIL WITH GREY CLAY
12.0				∅	BLACK SILTY MATERIAL; TRASH BAGS, PAPER, PLASTICS
14.0				∅	Dark Grey silty clayey material,
18.0					newspaper, plastic bags etc.
18-20				∅	DK GRAY TO BLACK; PLASTIC WASTE MAT'L
					VERY LITTLE SILT MATERIAL
28.0				∅	BLACK SOUPY MAT'L W/ PLASTIC, PAPER, ORGANICS AND COBBLE SIZED ROCKS.
34.0				∅	DK BROWN TO BLACK MATERIAL; SOUPY SILTY MATERIAL
39.0				∅	VERY LITTLE RECOVERY; WATERY; LITTLE SILT OR WASTE MATERIAL
44.0				∅	"SAA"
50.0				767	REFUSAL
55.0	SS1	9"		>1000	LIGHT BROWN MEDIUM SAND; LITTLE SILT COBBLES AND PEBBLES
57.0	SS2			6.5	BROWN MEDIUM SAND W/SILT PLUS PEBBLES
					dry
					EOB = 59.0'



McLAREN/HART

LEACHATE WELL

IB-3

PROJECT: CRC INTRUSIVE DRILLING

LOCATION: MORaine, OHIO

DRILLING METHOD: HSA

DATES OF COMPLETION: 10/29/90 - 10/30/90

DRILLING CONTRACTOR: BOWSER-MORNER

GEOLOGIST: HUNZEKER

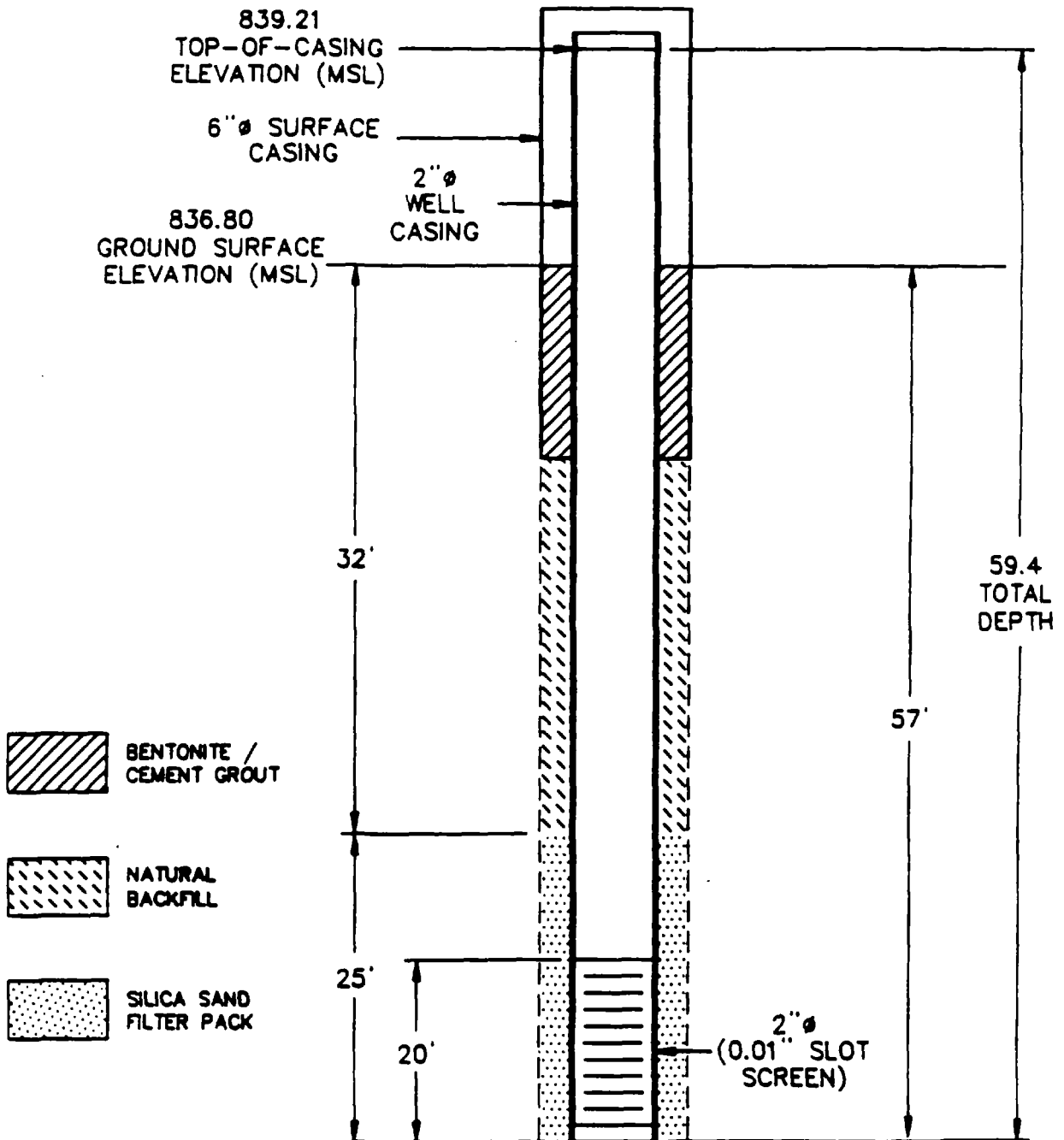

ALL DEPTHS ARE APPROXIMATE



SB Number IB-4
 Page: 1 OF 1
 Sampler(s): _____

SOIL DRILLING LOG

PROJECT: CRC
 SAMPLING DATE(S): 10-30-91 / 10-31-91 START: _____ FINISH: _____
 SAMPLING METHOD: _____
 LOCATION: MORaine, OHIO

SAMPLED DEPTH (FEET)	SAMPLE IDENTIFICATION	RECOVERY (FEET)	BLOWS PER SIX INCHES	HMu READING (PPM)	SOIL DESCRIPTION, COLOR, TEXTURE, MOISTURE, ETC.
0				φ	DARK BROWN CLAY (CLAY CAP)
5.0	7'-8' WASTE			φ	"SAA"
9.0				φ	BLACK CLAYEY MATERIAL; PAPER, PLASTIC TRASH BAG MATERIAL.
13.0 - 15.0				φ	BLACK SILTY MATERIAL; PLASTIC PAPER, CLOTH, MOIST, FOIL AND GRASS CLIPPINGS
19.0				φ	SAME MATERIAL WITH WOOD PRODUCTS AND PAPER
24.0				φ	UNDIFFERENTIATED SLUDGE, MOIST "SAA"
29.0				φ	BLACK SILTY WET MATERIAL, VERY LITTLE WASTE MATERIAL
34.0				φ	BLACK, WET SILTY WITH WOOD FRAGMENTS
39-44				φ	NO RECOVERY
45.0	SS 1	14"		75000	BROWN WELL SORTED MEDIUM SAND; DAMP; IRON STAINING, some c. sand
46.5 - 48.5	SS 2	15"		φ	BROWN MODERATELY SORTED, DRY MEDIUM SAND WITH PEBBLES
					EOB = 49.0'



McLAREN/HART

LEACHATE WELL

IB-4

PROJECT: CRC INTRUSIVE DRILLING

LOCATION: MORANE, OHIO

DRILLING METHOD: HSA

DATES OF COMPLETION: 10/30/90 - 10/31/90

DRILLING CONTRACTOR: BOWSER-MORNER

GEOLOGIST: HUNZEKER

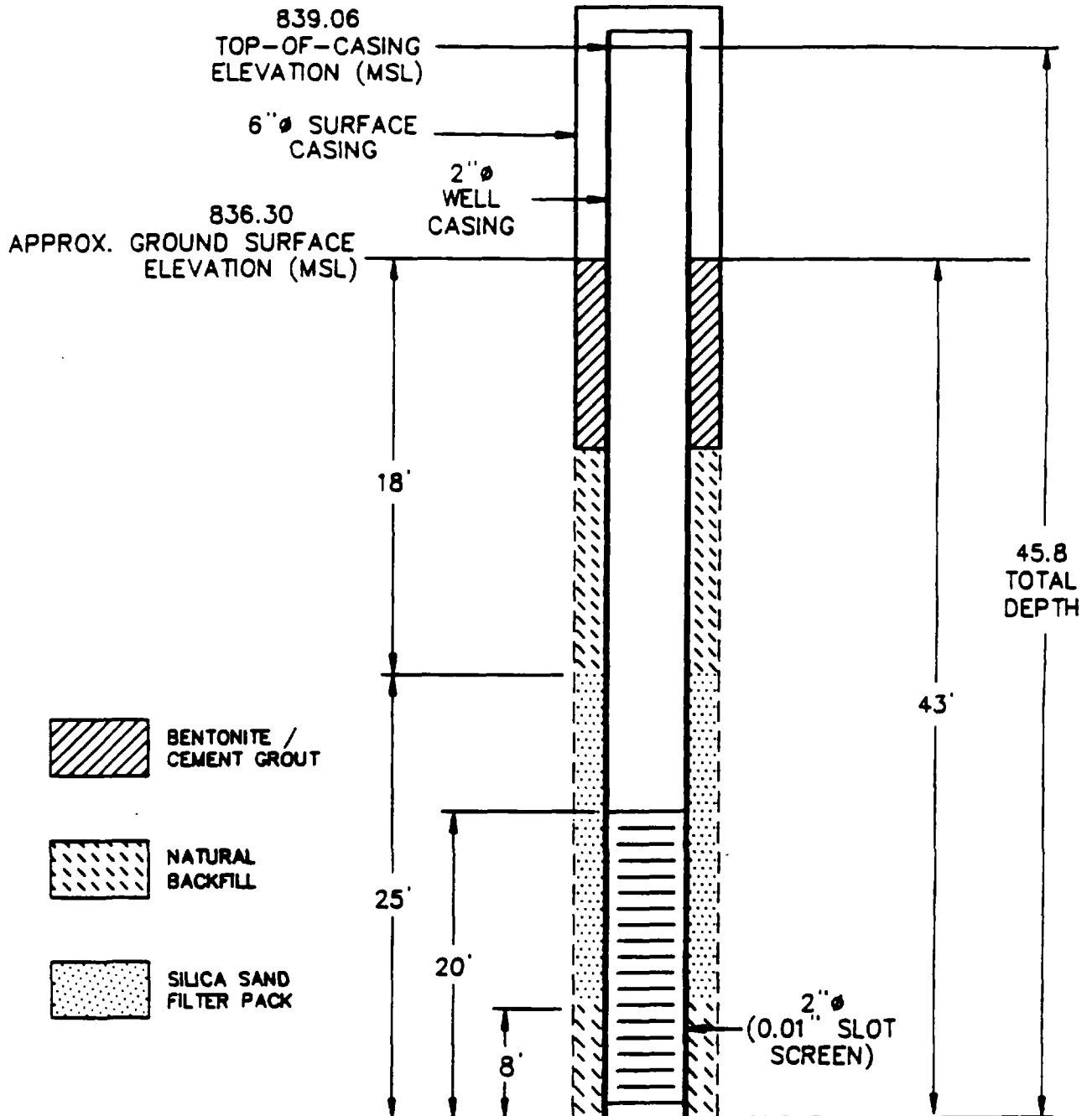

ALL DEPTHS ARE APPROXIMATE



SB Number IB-5
 Page: 1 OF 1
 Sampler(s): _____

SOIL DRILLING LOG

PROJECT: CRC
 SAMPLING DATE(S): 10-24-90 START: _____ FINISH: _____
 SAMPLING METHOD: _____
 LOCATION: MORaine, OHIO

SAMPLED DEPTH (FEET)	SAMPLE IDENTIFICATION	RECOVERY (FEET)	BLOWS PER SIX INCHES	HMU READING (PPM)	SOIL DESCRIPTION, COLOR, TEXTURE, MOISTURE, ETC.
0				∅	BROWN MEDIUM SAND, DRY
6'-8'					WASTE - ORGANIC WITH PAPER
15.0				∅	BLACK MUNICIPAL WASTE; ORGANICS WITH PAPER MATERIAL
20.0				∅	ORGANICS WITH LARGE AMOUNT OF PLASTIC; MORE MOIST.
24.0				∅	ORGANICS WITH RUBBER, PLASTICS AND PAPER.
29.0				∅	SAA; MORE DEGRADED, PLASTIC, STEEL BELTED TIRE.
34.0	SS1	6"		∅	BROWN SANDY SILT, PLASTIC, PEBBLES, WOOD, GREEN SUBSTANCE RESEMBLING GRASS CLIPPING
37.0		0		∅	NO RECOVERY
45.0	SS2	3-4"		350	ORGANICS WITH PLASTIC, ALUMINUM
49.5	SS3	18"		21.2	LIGHT BROWN DENSE CLAY TO DK GRAY TILL SOME PEBBLES. "BELIEVE TO BE NATIVE MTL"
					EOB = 50.0'



McLAREN/HART

LEACHATE WELL IB-5

PROJECT: CRC INTRUSIVE DRILLING

LOCATION: MORaine, OHIO

DRILLING METHOD: HSA

DATES OF COMPLETION: 10/24/90 - 10/26/90

DRILLING CONTRACTOR: BOWSER-MORNER

GEOLOGIST: HUNZEKER

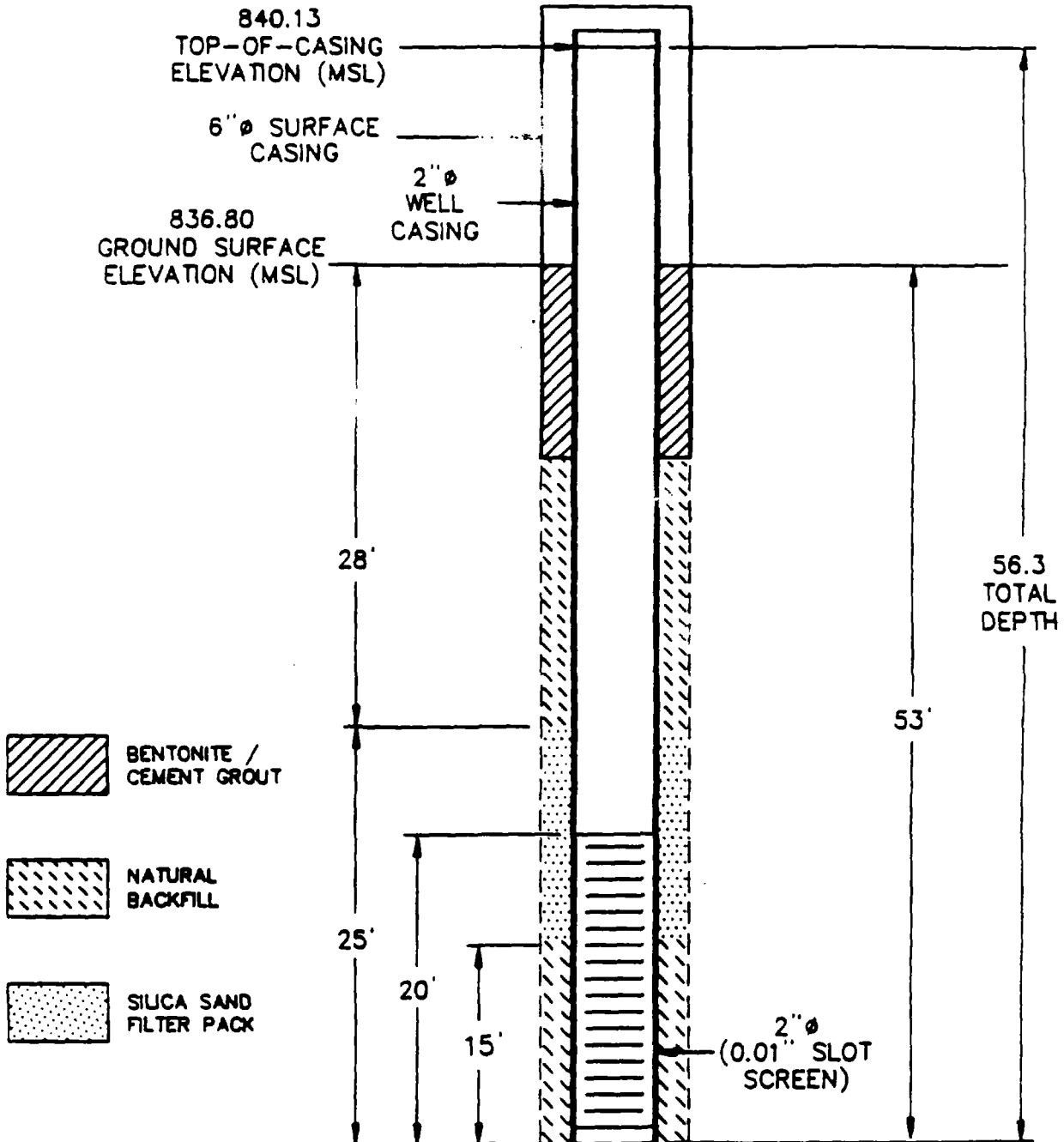

ALL DEPTHS ARE APPROXIMATE

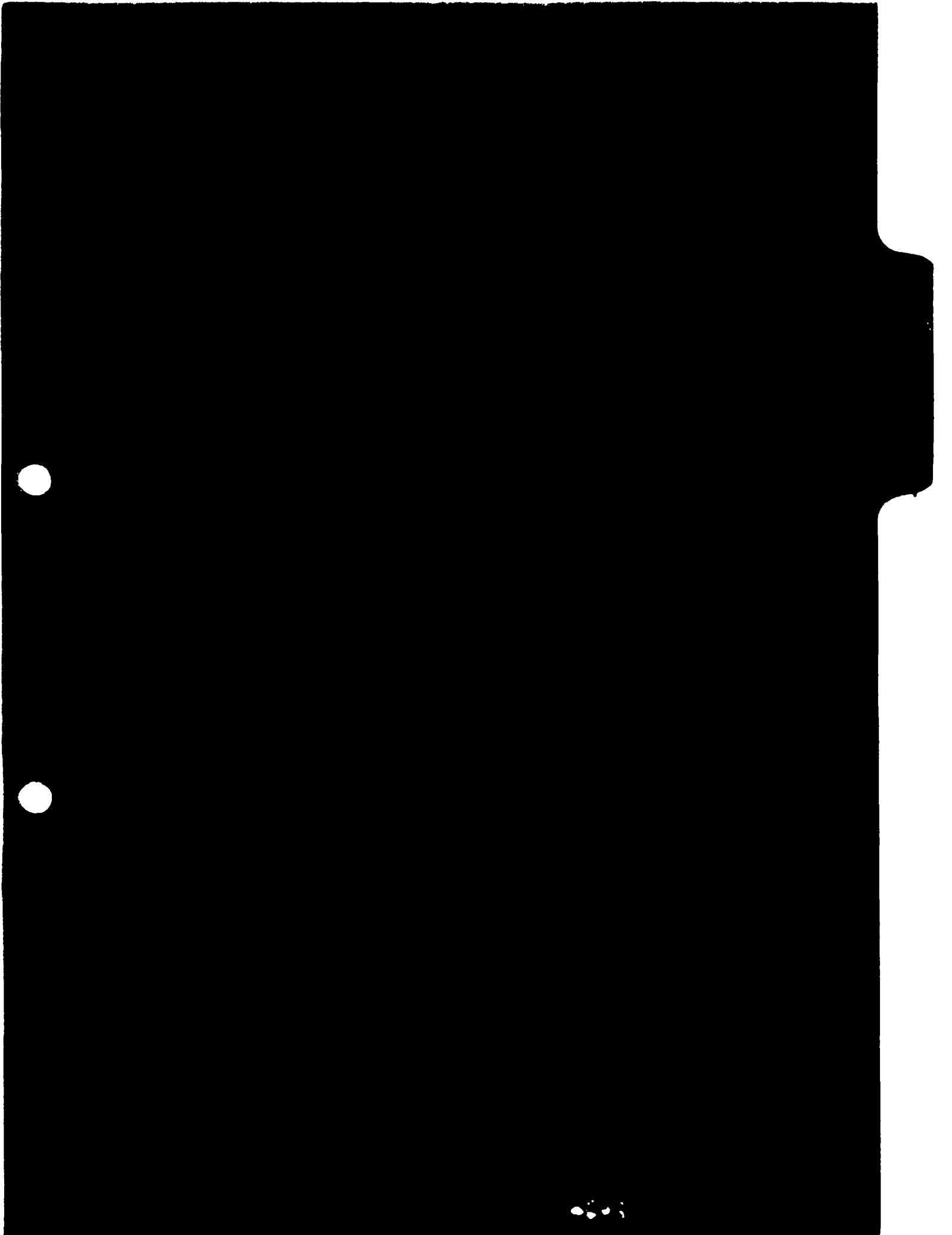

APPENDIX B

**TEST BORING LOGS FOR
PERIMETER MONITORING WELLS**



FRED C. HART ASSOCIATES, INC.

TEST BORING LOG

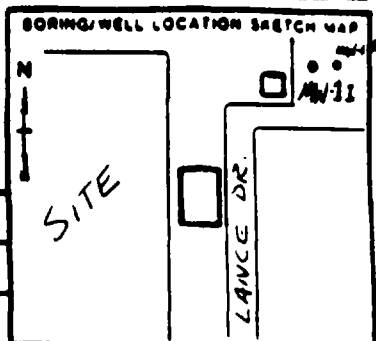

BORING NO. MW-11		PROJECT NO., NAME 0615-00-0002-02 / CRC		LOCATION DAYTON, OH	
DRILLING CONTRACTOR, DRILLER MID EASTERN GEOTECH / BILL AND WADE SIGLER				HART GEOLOGIST, OFFICE D. SHIELDS, J. KREJA / PGN	
DRILLING EQUIPMENT, METHOD CABLE TOOL		SIZE/TYPE OF BIT 6" Ø	SAMPLING METHOD CONTINUOUS SS	START, FINISH DATE 9/8/89 - 9/19/89	
WELL INSTALLED? YES <input checked="" type="checkbox"/> NO <input type="checkbox"/>	CASING MAT./DIA. 6" Ø BLACK STEEL	SCREEN TYPE	MAT. STAINLESS	LENGTH 20'	DIA. 2" SLOT SIZE 0.010
ELEVATION OF: (FT. ABOVE M.S.L.)		GROUND SURFACE	TOP OF WELL CASING	TOP & BOTTOM SCREEN	GW SURFACE DATE
REMARKS:					

LOG OF TEST BORING				WELL CONST.	GRAPHIC LITHO LOG
DEPTH (FT)	SAMPLE NO. AND TYPE	RECOVERY (FT)	PENETRATION RESISTANCE BLOW/FT		
0-1.5					
1.5-2					
2-3					
3-4.5					
4.5-6					
6-7.5					
7.5-9					
9-10.5					
10.5-12					
12-13.5					
13.5-15					
15-16.5					
16.5-18					
18-19.5					
19.5-20					

Proportions Used: Trace = 0-10%, Little = 10-20%, Some = 20-35%, And = 35-60%
 Sampling Abbreviations: SS = Split Spoon, ST = Shelby Tube, CSC = Continuous Soil Core



FRED C. HART ASSOCIATES, INC.

BORING NO.

MW-1I

LOG OF TEST BORING				WELL CONST.	GRAPHIC LITHO LOG
DEPTH (FT)	SAMPLE NO. AND TYPE	RECOVERY (FT)	PENETRATION RESISTANCE BLOW/FT		
22	8			CLAY-SILT-SAND-GRV, DRY-DAMP	OVA = 2 HNu = 0
24	9			SAA w/ BROKEN ROCK FRAG.	OVA = 4 HNu = 0
26	1.4			SILT AND F.C SAND, DRY-DAMP.	OVA = 4 HNu = 0
28	1.5			CLAY SILT, SAND, GRAVEL (< 3cm), POORLY SORTED, DRY-DAMP, MODERATELY TIGHT	OVA = 4.2 HNu = 0
30	1.7			SAA, TIGHT.	OVA = 4.4 HNu = 0
32	1.7			SAA	OVA = 3.8 HNu = 0
34	1.6			SAA	OVA = 4 HNu = 0
36	1.4			SAA	OVA = 2.2 HNu = 0
38	1.2			SAA	HNu = 0
40	1.4			SAA, SOME ROCK FRAG.	HNu = 0 END DRILL 9/11/89
42	1.7			CLAY, SILT, SAND, GRAVEL AND ROCK FRAG. POORLY SORTED, MODERATELY TIGHT, DAMP.	HNu = 0.6
44	1.8			SAA, DRY-DAMP.	HNu = 0.4
46	2.0			SAA, TIGHT.	HNu = 0
48	1.4			SAA	HNu = 0.4
50	1.7			SAA (1') SILTY-CLAY, DAMP, BROWN (.7')	HNu = 0



FRED C. HART ASSOCIATES, INC.

BORING NO. MW-1 I

LOG OF TEST BORING				WELL CONST.	GRAPHIC LITHO LOG
DEPTH (FT)	SAMPLE NO. AND TYPE	RECOVERY (FT)	PENETRATION RESISTANCE BLOW/FT	DESCRIPTION	REMARKS
52		1.7		SILTY - CLAY, DAMP, BROWN (1') C SAND + GRAVEL, SOME SILT (.7')	H _{Nu} = 0
54		1.5		CLAY AND GRAVEL (2.4cm)	H _{Nu} = 0
56		2		F-M SAND VF SAND AND SILT	H _{Nu} = 0 0.5 SATURATED 2 NOA SAMPLES COLLECTED
58				NO RECOVERY	
60		2		GRAY CLAY, DRY-DAMP, FIRM, w/ SOME SMALL GRAVEL.	H _{Nu} = 0
62		1.3		SAA (0.8') C SAND AND GRAVEL, DRY (0.5').	H _{Nu} = 0
64		1.5		SAA (0.5') CLAY, C SAND AND GRAVEL, DRY, TIGHT. (0.7') BROWN CLAY w/SOME GRAVEL, DAMP, FIRM (0.3')	H _{Nu} = 0
66		1.7		M SAND, BROWN, DAMP, WELL SORTED. (1.0') SAND AND GRAVEL AND ROCK FRAG, DRY-DAMP, MOD LOOSE. (0.7')	H _{Nu} = 0
68		1.2		ROCK, SAND AND GRAVEL, DRY-DAMP.	H _{Nu} = 0
70		1.3		SAA	H _{Nu} = 0
72		1.4		SAA, LITTLE ROCK	H _{Nu} = 0
74		1.5		SAA (1.0') CLAY, C. SAND AND GRAVEL (0.5')	H _{Nu} = 0.6
76		1.5		INTBD CLAY AND C SAND w/SOME GRAVEL (2.3/4cm), WET (0.5'). BROWN-GRAY CLAY w/SOME SAND, DRY-DAMP (1.0')	H _{Nu} = 0
78		1.2		SAND AND GRAVEL (2.5cm Ø) (0.8'). WELL SORTED M SAND, DAMP (0.4').	H _{Nu} = 0
80		1.2		M SAND, BROWN, MOIST. (0.7') F SAND, BROWN, MOIST (0.5')	H _{Nu} = 0



FRED C. HART ASSOCIATES, INC.

Page 4 of 5
 BORING NO. MW-1I

LOG OF TEST BORING				WELL CONST.	GRAPHIC LITHO LOG
DEPTH (FT)	SAMPLE NO. AND TYPE	RECOVERY (FT)	PENETRATION RESISTANCE BLOW/FT	DESCRIPTION	REMARKS
82	1.2			SAND, GRAVEL (0.2') F-C SAND, MOIST LOOSE (0.5') BROWN CLAY, FIRM, DRY-DAMP (0.5')	HNu = 0
84	2			GRAY-BROWN CLAY, SOFT, DAMP	HNu = 0
86	1.8			SAA (1.1') BROWN CLAY (0.3')	HNu = 0 END DRILL 9/12/89
88	1			SAND AND GRAVEL (0.4') SAND, GRAVEL, ROCK FRAG., DRY, MOD. LOOSE	HNu = 0
90	1.5			SAA W/CLAY, TIGHT.	HNu = 0
92	1.6			SAND AND GRAVEL (< 2in Ø) W/ LITTLE CLAY, DAMP, MOD. TIGHT.	HNu = 0
94	1			SAA	HNu = 0
96	1.2			GRAVEL AND ROCK FRAGM., MOST-WET.	HNu = 0
98	1.5			CLAY, GRAVEL AND ROCK FRAG., WET	HNu = 0
100	1.2			SAA, 70 CLAY ↑ W/ DEPTH	HNu = 0
102	1			SILT, CLAY AND ROCK FRAG, DRY	HNu = 0
104	1.1			SAA W/SOME GRAVEL	HNu = 0
106	1.2			CLAY - C. SAND AND GRAVEL, MOIST-WET.	HNu = 0
108	1			SAA, W/ROCK FRAG., WET.	HNu = 0
110	1.2			C SAND AND GRAVEL, SATURATED.	HNu = 0 ♀ @ 108' COLLECTED TO VCA'S



FRED C. HART ASSOCIATES, INC.

BORING NO. MW-1 I

LOG OF TEST BORING				WELL CONST.	GRAPHIC LITHO LOG
DEPTH (FT)	SAMPLE NO. AND TYPE	RECOVERY (FT)	PENETRATION RESISTANCE BLOW/FT		
112		1.2		C SAND, GRAVEL, ROCK FRAG, SATURATED	H _{Nu} = 0 BEGIN COMPOSITE SAMPLE
114		.9		SAA	H _{Nu} = 0 COMPOSITE
116		.8		SILT, GRAVEL, AND ROCK FRAG.	H _{Nu} = 0 COMPOSITE
118		1.5		CLAY, SILT, C SAND, GRAVEL TIGHT, DAMP HARD PAN (CLAY AND GRAVEL) (0.2')	H _{Nu} = 0
120		2		SAND + GRAVEL, SOME CLAY	H _{Nu} = 0 COLLECTED 2 VOA'S BEGIN 2 ND COMPOSITE
122		1.8		C SAND AND GRAVEL, LOOSE, SATURATED.	H _{Nu} = 0
124		1.2		C SAND AND GRAVEL w/ SOME CLAY, SATURATED.	H _{Nu} = 0
126		.8		SAA	H _{Nu} = 0
128		.6		SAA w/ LS FRAG @ BOTTOM.	H _{Nu} = 0 SPoon REFUSAL @ 8"
130		.8		HARD PAN - CLAY, SAND, GRAVEL, V. DENSE, TIGHT, DAMP.	H _{Nu} = 0 SPoon REFUSAL @ 1.1' END DRILL 9/15/89
				T.D. = 130'	



FRED C. HART ASSOCIATES, INC.

TEST BORING LOG

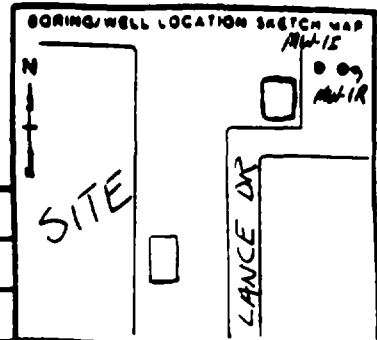

BORING NO. <i>MW-1R</i>		PROJECT NO. NAME <i>00615-00-00002-02/CRC</i>		LOCATION <i>DAYTON, OH</i>	
DRILLING CONTRACTOR, DRILLER <i>MID-EASTERN GEOTECH / BILL SIGLER</i>					
HART GEOLOGIST, OFFICE <i>D. SHIELDS, T. ROYER</i>					
DRILLING EQUIPMENT, METHOD <i>CABLE TOOL</i>		SIZE/TYPE OF BIT <i>10" & TO 128'</i>		SAMPLING METHOD <i>SS - 5' INTERVAL</i>	
WELL INSTALLED? YES <input checked="" type="checkbox"/> NO <input type="checkbox"/>		CASING MAT./DIA. <i>10" BLACK STEEL, 6" BS.</i>		SCREEN TYPE <i>MAT. STAINLESS LENGTH 10 DIA. 2" SLOT SIZE 0.010</i>	
ELEVATION OF: (FT. ABOVE M.S.L.)		GROUND SURFACE		TOP OF WELL CASING	
		TOP & BOTTOM SCREEN		GW SURFACE	
REMARKS:				DATE	

LOG OF TEST BORING				WELL CONST.	GRAPHIC LITHO LOG	
DEPTH (FT)	SAMPLE NO. AND TYPE	RECOVERY (FT)	PENETRATION RESISTANCE BLOWS/FT			DESCRIPTION
0						<p>No SAMPLES COLLECTED UNTIL 130'</p> <p>(REFER TO MW-1A BORING LOG FOR 0-130')</p>
1						
2						
3						
4						
5						
6						
7						
8						
9						
10						
11						
12						
13						
14						
15						
16						
17						
18						
19						
20						

Proportions Used: Trace = 0-10%, Little = 10-20%, Some = 20-35%, And = 35-50%
 Sampling Abbreviations: SS = Split Spoon, ST = Shelby Tube, CSC = Continuous Soil Core



FRED C. HART ASSOCIATES, INC.

BORING NO.

MW-1R

LOG OF TEST BORING

DEPTH (FT)	SAMPLE NO. AND TYPE	RECOVERY (FT)	PENETRATION RESISTANCE BLOW/FT	DESCRIPTION	REMARKS	WELL CONST.	GRAPHIC LITHO LOG
130							
132	1			SILTY CLAY, GRAVEL + ROCK FRAG, POORLY SORTED, TIGHTLY PACKED (HARD PAN), LT BR, DRY.	HNu = 0		
134	1			AS ABOVE	HNu = 0		
136	1			AS ABOVE	HNu = 0		
138	1			SILTY CLAY - GRAVEL, POORLY SORTED, TIGHTLY PACKED (HARD PAN) LT BR, DRY. (0.5') ROCK FRAGS LT GR, "POKER-CHIP" GRAVELS	HNu = 0		
140				SILTY CLAY AND GRAVEL, POORLY SORTED, TIGHTLY PACKED (HARD PAN) LT BR, DRY			
142	.5			CLAY + GRAVEL (WELL-ROUNDED) POORLY SORTED, TIGHTLY PACKED (HARD PAN OR TILL), LT BR, DRY.	HNu = 0		
145							
147	1'			AS ABOVE	HNu = 0		
150							
152	2			SAND MED GR, WELL SORTED, W/CLAY + GRAVEL TOWARDS BOTTOM.	HNu = 0		
155							
157	1			SILTY CLAY + GRAVEL (ROUNDED) TIGHTLY PACKED (TILL - OR - HARD PAN) LT BR, DRY.	HNu = 0		



FRED C. HART ASSOCIATES, INC.

BORING NO. MW-1R

				LOG OF TEST BORING		WELL CONST.	GRAPHIC LITHO LOG
DEPTH (FT)	SAMPLE NO. AND TYPE	RECOVERY (FT)	PENETRATION RESISTANCE BLOWS/FT	DESCRIPTION	REMARKS		
160				AS ABOVE	HNu = 0		
162	1						
165				AS ABOVE	HNu = 0		
167	.25						
170				SILTY CLAY AND GRAVEL (ROUNDED) TIGHTLY PACKED (TILL OR HARD PAN) LT BR, DRY.	HNu = 0 SPDN REFUSAL @ 1'		
172	25						
175				SAND, LT BR, FN-MED GR, LT BR w/DK BR (OXIDATION) STREAKS, WET (1.0')	HNu = 0		
177	1.5			SILTY CLAY AND GRAVEL (ROUNDED) TIGHTLY PACKED LT BR, WET (0.5')			
180				GRAVEL, WELL ROUNDED w/SILTY CLAY + FINE SAND, LT BR, LOOSELY PACKED, WET.	HNu = 0		
182	1.5						
185				MID BROWN SATURATED; LOOSE POORLY SORTED FM GRAVEL; MCF SAND, 5-10% FINES	HNu = 0		
187				GRAVEL WELL-ROUNDED TO SL. ANGULAR.			



FRED C. HART ASSOCIATES, INC.

BORING NO. MW-1R

				LOG OF TEST BORING		WELL CONST.	GRAPHIC LITHO LOG
DEPTH (FT)	SAMPLE NO. AND TYPE	RECOVERY (FT)	PENETRATION RESISTANCE BLOW/FT	DESCRIPTION	REMARKS		
190 192	1.7			V. TIGHT, 60-70% FINES, SOME F GRAVEL FMC SAND, BROWN, ALL DAMP-MOIST	H _{Nu} = 0		
195							
197	2.0			ALTERNATING RED-BROWN SILT W/ LITTLE FSAND TR CLAY AND GRAY BROWN W/ OXIDATION TIGHTER MAT'L 70% FINES LITTLE FGRAVEL + MC SAND TR ROOT MAT'L IN RED BROWN MAT'L, MOIST	H _{Nu} = 0		
199 1/2							
201 1/2	.5			DAMP, 410% FINES, FMC SAND + F GRAVEL (LOOKS LIKE D. GRAY FRAGS) 1 LARGE PEBBLE WELL ROUNDED QUARTZ - SL. TIGHT-CRUMBLY			
205							
207	.75			SEVERAL INCHES OF BROWN GRAY RX FORESTRONE TOP PIECE WAS ROUNDED ON TOP SIDE, INDICATING IT WAS PROBABLY A COBBLE SILTSTONE. REMAINING MAT'L WAS CRUMBLY - MULTICOLORED + DAMP MADE UP OF CRUSHED RX OF VARIOUS ORIGINS - SOME PIECES W/ ROUNDING			
210							
212	.5			RUST BROWN HARD PAN - CRUSHED STONE 10% FINES; MOIST; TIGHT MAT'L	H _{Nu} = 0 SAMPLE COLLECTED FOR VOA's		
215							
217	.5			PIECES OF CRUSHED RX GRAY SILT/LIMESTONE BROWN CONGLOMERATE-LIKE LOOKING RX. - SILTSTONE; 15% FINES RED-BROWN DAMP TO MOIST	H _{Nu} = 0		



FRED C. HART ASSOCIATES, INC.

BORING NO. MW-1R

LOG OF TEST BORING

220

DEPTH (FT)	SAMPLE NO. AND TYPE	RECOVERY (FT)	PENETRATION RESISTANCE BLOW/FT	DESCRIPTION	REMARKS	WELL CONST.	GRAPHIC LITHO LOG
222	.5			PIECES OF CRUSHED SILT/LIMESTONE RED BROWN + GRAY COLOR TR FINES DAMP	H _N u = 0		
225							
227	0			No RECOVERY (M.C SAND)			
230							
232	.3			(TR FINES) SATURATED SAND + GRAVEL (OUTWASH)	H _N u = 0		
235							
237	1			SATURATED SAND + GRAVEL W/ SILT	H _N u = 37pm V _u 's COLLECTED (18235-237)		
240							
242	1			SAND + GRAVEL W/SILTY SAND SATURATED	H _N u = 0 COLLECTED SAMPLE (18240-242)		
245							
247	.4			COARSE SAND + GRAVEL W/ SOME FINES SATURATED	H _N u = 0		



FRED C. HART ASSOCIATES, INC.

BORING NO.

MW-1R

LOG OF TEST BORING

WELL CONST.

GRAPHIC LITHO LOG

DEPTH (FT)
SAMPLE NO. AND TYPE
RECOVERY (FT)
PENETRATION RESISTANCE BLOW/FT

DESCRIPTION

REMARKS

250

252	.1		SILTY (GLOWN) COARSE SAND - GRAVEL, SATURATED	H _{Nu} = 160 ppm (PICK) (M+E's H _{Nu} = 0) CLAY @ ~250'
253	1		GRAY CLAY w/ GRAVEL, TIGHT, MOIST	H _{Nu} = 0 VOM'S COLLECTED (13 252-253')
255				
257	.3		TIGHT GRAY CLAY w/ TR GRAVEL, DAMP	H _{Nu} = 0 SAMPLE COLLECTED
260				
262	.4		TIGHT GRAY CLAY w/ SHALE FRAGS + GRAVEL, DAMP.	H _{Nu} = 4 ppm
265				SHALE: CLAY ↑
267	.3		TIGHT GRAY CLAY w/ SHALE FRAGS + TR GRAVEL (DAMP)	H _{Nu} = 6 ppm (CONT. COMPOSITE SAMPLE) SHALE @ 267-268 w/ LIMESTONE
269 1/2			CUTTINGS ONLY - CLAY w/ SHALE	
270 1/2			GRAY SHALE w/ GRAY CLAY, SATURATED.	H _{Nu} = 0
272				

T.D. = 272'



FRED C. HART ASSOCIATES, INC.

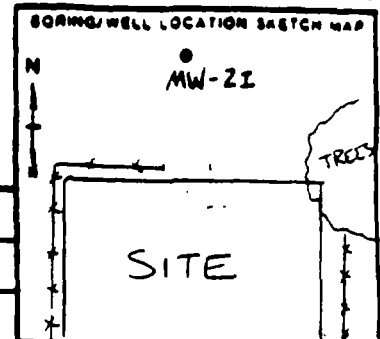

TEST BORING LOG

BORING NO. MW-21			
PROJECT NO. NAME 00615-00-00002-02 / CRC DAYTON	LOCATION DAYTON, OH		
DRILLING CONTRACTOR, DRILLER MID-EASTERN GEOTECH / BILL AND WADE SIGLER			
HART GEOLOGIST OFFICE DON SHIELDS / PGH			
DRILLING EQUIPMENT, METHOD CABLE TOOL	SIZE/TYPE OF BIT 6" Ø	SAMPLING METHOD SS CONTINUOUS	START, FINISH DATE 8/29/89 - 9/7/89
WELL INSTALLED? YES <input checked="" type="checkbox"/> NO <input type="checkbox"/>	CASING MAT./DIA. BLACK STEEL / 6" Ø	SCREEN TYPE MAT. SS	LENGTH 10 DIA. 2" SLOT SIZE 01
ELEVATION OF: (FT. ABOVE M.S.L.)	GROUND SURFACE	TOP OF WELL CASING	TOP & BOTTOM SCREEN GW SURFACE
REMARKS:			

LOG OF TEST BORING				WELL CONST.	GRAPHIC LITHO LOG
DEPTH (FT)	SAMPLE NO. AND TYPE	RECOVERY (FT)	PENETRATION RESISTANCE BLOWS/FT		
DESCRIPTION				REMARKS	
2	1.5				FILL: SAND, FN GR, LT BR AND ROCK FRAGMENTS LT GRAY, ANGULAR, DRY HNu = 0
4	1.5				FILL: SAND FN GR, LT BR, ROCK FRAGS, ROUNDED, LT GREY, DRY (6") CLAY BRNISH GREY, DRY, GRAVEL INTERSPERSED SOME RED SPLOTCHES (PROBABLY FILL), DRY HNu = 0
5	2				CLAY, DK GREY +/- GRAVEL, ROUNDED, LT GREY, INTERSPERSED, DRY HNu = 0
6					
8	1				SAND, FN-GR, LT BR, SOME SMALL GRAVEL INTERSPERSED, DRY HNu = 0
10	2				SAND, M-C GR, BR, GRAVEL, WELL-ROUNDED INTERSPERSED, DRY HNu = 0
12	1				AS ABOVE, MOIST HNu = 0
14	1				AS ABOVE HNu = 0
18	1				SILT + FN GR SAND, LT BR w/LARGE GRAVEL (1"), ANGULAR AND ROUNDED, DRY HNu = 0
16					
18	.5				SH ROCK FRAGMENTS, ANGULAR + SUB ROUNDED, GREY, SOME F SAND, LT BR, MOIST HNu = 0
19					
20	1				SAND, COARSE GR, LT BR + GRAVEL LARGE COBBLE (2") @ BOTTOM OF SS HNu = 0

Proportions Used: Trace = 0-10%, Little = 10-20%, Some = 20-35%, And = 35-60%
 Sampling Abbreviations: SS = Split Spoon, ST = Shelby Tube, CSC = Continuous Soil Core



FRED C. HART ASSOCIATES, INC.

BORING NO.
MW-2 I

20

LOG OF TEST BORING				WELL CONST.	GRAPHIC LITHO LOG
DEPTH (FT)	SAMPLE NO. AND TYPE	RECOVERY (FT)	PENETRATION RESISTANCE BLOW/FT		
22	1.5			SAND, COARSE GR, LT BR, + GRAVEL, WET	HNu = 0
24	1			AS ABOVE, WET.	HNu = 0
26	1			SAND, FN-MED GR, LT BR, w/GRAVEL, DAMP	HNu = 0
28	.5			CLAY, BROWN, DRY	HNu = 0 BEGIN DRILL 8/30/89
30	1.5			SILTY CLAY, LT BR, DRY SOME GRAVEL @ BOTTOM, DRY	OVA = 3ppm (HIGH HUMIDITY CAUSES ERRATIC HNu)
32	1.5			SAND, MED GR, LT BR, w/GRAVEL (1-2") CLASTS, DRY	OVA = 2ppm
34	1.5			SAND, MED GR, LT BR, AND GRAVEL (1" CLASTS), DRY	HNu = 0
36	1.5			SILT AND F.SAND, LT BR, w/GRAVEL + ROCK FRAGS (ANGULAR) ~1" CLASTS, DRY	HNu = 0
38	1.5			AS ABOVE	HNu = 1ppm
40	2			AS ABOVE	HNu = 0.5ppm
42	2			SILT AND FINE SAND, LT BR w/ GRAVEL (.25") WELL ROUNDED, INTERSPERSED, DRY	HNu = 0
44	2			SAND, COARSE GR, LT BR, WELL SORTED, SOME GRAVEL @ BOTTOM, DRY.	HNu = 0
46	1.5			SILT + F SAND, LT BR, SOME GRAVEL, DRY.	HNu = 0
48	1			SILT, F SAND + GRAVEL MIXED LT BR, DRY	HNu = 0
50	1			AS ABOVE	HNu = 0



FRED C. HART ASSOCIATES, INC.

BORING NO. MW-2I

LOG OF TEST BORING

WELL CONST.
GRAPHIC LITHO LOG

DEPTH (FT)	SAMPLE NO. AND TYPE	RECOVERY (FT)	PENETRATION RESISTANCE BLOW/FT	DESCRIPTION	REMARKS	WELL CONST.	GRAPHIC LITHO LOG
52	2			AS ABOVE	HNu = 0		
54	1.5			AS ABOVE	HNu = 0		
56	2'			AS ABOVE	HNu = 0		
58	1			SILT AND F SAND + GRAVEL (ROUNDED + ANGULAR CLASTS, WELL MIXED, DRY	HNu = 0		
60	1.5			AS ABOVE	HNu = 0		
62	1			AS ABOVE	HNu = 0		
64	1			AS ABOVE	HNu = 0		
66	1.5			SILT AND SAND (F-C GRAIN), SOME GRAVEL (ROUNDED, < 1" φ) LT BR, DAMP.	HNu = 0		
68	2'			AS ABOVE	HNu = 0		
70	1.5			AS ABOVE	HNu = 0		
72	2			AS ABOVE	HNu = 0.5ppm		
74	1.5			AS ABOVE	HNu = 0		
76	1.5			SAND, F-C GR, LT BR, POORLY SORTED, DRY	END DRILLING 8/30/89 HNu = 0		
78	1.5			M-C SAND, SOME GRAVEL, LT BROWN, W/ROCK FRAGMENTS, ANGULAR, LT GRAY, DRY	HNu = 0		
80	1.5			F-C SAND AND GRAVEL, WELL-ROUNDED, LT BR, DAMP; SOME ORGANIC MATERIAL	HNu = 0		

70



FRED C. HART ASSOCIATES, INC.

BORING NO. MW-21

LOG OF TEST BORING

DEPTH (FT)
 SAMPLE NO. AND TYPE
 RECOVERY (FT)
 PENETRATION RESISTANCE BLOW/FT

DESCRIPTION

REMARKS

WELL CONST.

GRAPHIC LITHO LOG

80

82	1.5	AS ABOVE	HNu = 0
84	1	SILTY F SAND + GRAVEL, SOME ROCK FRAGMENTS, LT BROWN, DAMP	HNu = 0
86	1	SILT + GRAVEL, POORLY SORTED, BROWN, DAMP, TIGHTLY PACKED.	HNu = 0
88	1.5	AS ABOVE, DRY	HNu = 0
90	2	AS ABOVE	HNu = 0
92	1	ROCK FRAGMENTS, GREY, SILTY-CLAY INTERSPERSED, DRY	HNu = 0 SPoon REFUSAL @ 1'
94	1	AS ABOVE	HNu = 0 SPoon REFUSAL @ 1.5'
96	1	ROCK FRAGS, ANGULAR, LT BR MIXED W/CLAY, DK GREY, SOME GRAVEL, DRY	HNu = 0
98	1.5	GRAVEL WELL ROUNDED, LT BRN-GREY, W/CLAY INTERSPERSED. CLAY CONTENT DECREASES TOWARD BOTTOM.	HNu = 0
100	1.5	AS ABOVE, WET?	HNu = 0
102	1.5	SAME AS ABOVE (1.0') CLAY - LT BR, STIFF, SMALL GRAVEL INTER MIXED, DRY (0.5')	
104	2'	CLAY, MASSIVE, GREY, DRY	HNu = 0
106	2	AS ABOVE	HNu = 0
108	1.5	AS ABOVE (0.5') SAND, FN GR, LT BR, WET (1.0')	HNu = 0 COLLECTED VOA & SBOZA (106-108')
110	1.5	SILTY SAND, LT. BR, DRY. SOME ROCK FRAG. AT BASE.	HNu = 0



FRED C. HART ASSOCIATES, INC.

BORING NO. MW-2I

LOG OF TEST BORING

110

DEPTH (FT)	SAMPLE NO. AND TYPE	RECOVERY (FT)	PENETRATION RESISTANCE BLOWS/FT	DESCRIPTION	REMARKS	WELL CONST.	GRAPHIC LITHO LOG
112		1.5		SILT, LT GREY, MASSIVE, DRY	HNu = 0 END DRILL 9/1/89 START DRILL 9/5/89		
115							
117		1.5		ADD, DK BRN SILTY CLAY + GRAVEL (SPARSE), DRY.	HNu = 0		
120							
122		.5		SAND, FN GR, LT BR, SOME GRAVEL @ BASE, DRY	HNu = 0 SPIN RESUAL @ 1.5		
125							
127				GRAVEL ROUNDED AND ANGULAR CLASTS (1mm - 2"), SILTY SAND (HARD FIN)			
130							
132		1		AS ABOVE	HNu = 0		
135							
137		1		SILT, GREENISH GRAY, SOME GRAVEL, DRY	HNu = 0		



FRED C. HART ASSOCIATES, INC.

BORING NO.
MW-2I

LOG OF TEST BORING				WELL CONST.	GRAPHIC LITHO LOG
DEPTH (FT)	SAMPLE NO. AND TYPE	RECOVERY (FT)	PENETRATION RESISTANCE BLOW/FT		
140					
142		.5		ROCK FRAGMENTS - SH, LT GREY, PLATY, DRY	H _{Nu} = 0
145					
147		.5		SAND + GRAVEL, LT. BR, WET	H _{Nu} = 0 SPON REFUSAL @ 1.0'
150					
152		1.5		M-C SAND, LT BR + GRAVEL, WELL MIXED, WET	H _{Nu} = 0 SAMPLE COLLECTED (SBOZA 150-152)
155					
157		1'		AS ABOVE, WET	H _{Nu} = 0 END DRILL 9/6/89
T.D. = 157'					



FRED C. HART ASSOCIATES, INC.

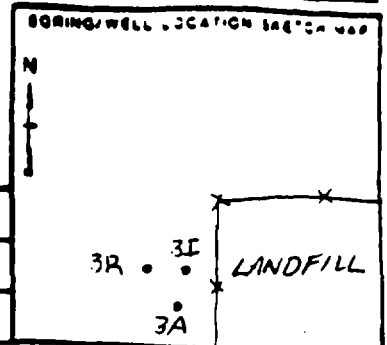

TEST BORING LOG

BORING NO. MW03A	
PROJECT NO. NAME CARDINGTON ROAD LANDFILL	LOCATION MCRRAINE, CHIC
DRILLING CONTRACTOR, DRILLER BOWSER-MORNER, JEFF RIDDLE	
HART GEOLOGIST OFFICE MARTHA FLEMING, PITTSBURGH	
DRILLING EQUIPMENT, METHOD CABLE TOOL, BUCKRUS W-22	SIZE, TYPE OF BIT NOMINAL 7"
SAMPLING METHOD SPLIT SPOCCIN	START, FINISH DATE 07/13/90-07/16/90
WELL INSTALLED? YES <input checked="" type="checkbox"/> NO <input type="checkbox"/>	CASING MAT., DIA. 2" STAINLESS
SCREEN: SCH 40 TYPE 304	MAT. STAINLESS LENGTH 10' DIA. 2" SLOT SIZE 1/8"
ELEVATION OF: (FT. ABOVE M.S.L.)	GROUND SURFACE TOP OF WELL CASING TOP & BOTTOM SCREEN GW SURFACE DATE
REMARKS:	

LOG OF TEST BORING				WELL CONST.	GRAPHIC LITHO LOG	
DEPTH (FT)	SAMPLE NO. AND TYPE	RECOVERY (FT)	PENETRATION RESISTANCE BLOWS/FT			DESCRIPTION
75						
	.7				BROWN MFC SAND; 10% GRAVEL (<0.5cm) AND 10% SILT; DRY, POORLY SORTED; LOOSE MODERATELY LOOSE	HNU = 0.4 ppm (above background)
	1.0				SAME AS ABOVE	HNU = 1.4 ppm
80					SAME AS ABOVE (5% GRAVEL AND 20% SILT)	HNU = 1.2 ppm
	1.8				BROWN MFC SAND; 5% GRAVEL (<0.5cm) AND 5% SILT; DAMP TO MOIST; SORTED; MODERATELY LOOSE	HNU = 0.8 ppm
85					BROWN MFC SAND, 5% SILT; DAMP TO DRY, MODERATELY LOOSE	HNU = 0.8 ppm
	.7				BROWN FM SAND, <5% SILT, DRY, MODERATELY LOOSE	HNU = 1.2 ppm
	.8				BROWN FM SAND, <5% SILT AND <5% ROUNDED GRAVEL (<0.5cm), DAMP; MODERATELY TIGHT	

Penetration Resist. Tests: 0-10% Little = 10-20% Some = 20-35% And = 35-50%



FRED C. HART ASSOCIATES, INC.

BORING NO. MW03A

LOG OF TEST BORING					WELL CONST.	GRAPHIC LITHO LOG
DEPTH (FT)	SAMPLE NO. AND TYPE	RECOVERY (PT)	PENETRATION RESISTANCE BLOW/FT	DESCRIPTION		
	ND			SAME AS ABOVE (DRY TO DAMP)	HNU = 0.6 ppm	
	ND			SAME AS ABOVE (10%+ SILT AND WET)	HNU = 0.4 ppm	
95	1.5			SAME AS ABOVE (10-15% FINES AND WET) BROWN-REDBROWN CLAY AND SILT, DAMP; TIGHT	HNU = 0 ppm	
100				T.D. 99'		



FRED C. HART ASSOCIATES, INC.

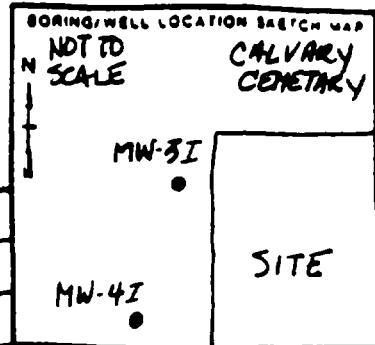

TEST BORING LOG

BORING NO. MW-3I	
PROJECT NO. NAME 0065-00-00002-02 / CRC	LOCATION DAYTON, OH
DRILLING CONTRACTOR, DRILLER MID-EASTERN GEOTECH / BILL AND WADE SIGLER	
HART GEOLOGIST OFFICE MCCREA, TRONEK / PITTSBURGH	
DRILLING EQUIPMENT, METHOD CABLE TOOL	SIZE/TYPE OF BIT 6" φ
SAMPLING METHOD 2' CONT. SS	START, FINISH DATE 7/28
WELL INSTALLED? YES <input checked="" type="checkbox"/> NO <input type="checkbox"/>	CASING MAT., DIA. BACKSPEL / 6"
ELEVATION OF: (FT. ABOVE M.S.L.)	SCREEN: TYPE MAT. STAINLESS LENGTH 10' DIA. 2" SLOT SIZE
ELEVATION OF: (FT. ABOVE M.S.L.)	
REMARKS:	

LOG OF TEST BORING				WELL CONST.	GRAPHIC LITHO LOG
DEPTH (FT)	SAMPLE NO. AND TYPE	RECOVERY (FT)	DESCRIPTION		
	1		BRN SILTY CLAY w/ C SAND, SP SO, SAND % ↑ w/DEPTH, DAMP.		
	2		TOP 1' - SAA 8" = SILTY SAND w/ SOME CLAY, RED-BRN, DRY. 4" = MC SAND, BRN, LO, SO, DRY		
5	1.5		6" = RED BRN SILTY C SAND, w/ SOME CLAY, DRY SS, SP, SOFT 6" = TAN SILT, DRY SO, PO, SOFT 6" = M-F SAND, TAN, SO, LO, DRY.		
	1		M-C-VC TAN WHITE SAND, w/ < 5% GRAVEL SO, LO, POORLY SORTED, DRY.		
	1.5		M-C TAN WHITE SAND, SO, LO, DRY, MOD. WELL-SORTED		
10	1.5		F-M-C SAND w/ 10% GRAVEL (< 2mm φ), POORLY SORTED LO, SO, DRY.		OVA = 0.8
	1		BRN M-C SAND w/ SOME SILT AND F SAND AND 10% GRAVEL (< 1/2mm), POORLY SORTED, LOOSE		
15	1.3		BRN F-M SAND AND SILT w/ SOME GRAVEL (< 2mm φ)		
	1.5		1" = M-C BRN SAND w/ VC SAND AND GRAVEL, MOIST, POORLY SORTED. 6" = M-C BRN-WHITE SAND w/ SOME F SAND, DRY.		
			F-C BRN SAND, DAMP, LO, SOFT, POORLY SORTED		

Proportions Used: Trace = 0-10%, Little = 10-20%, Some = 20-35%, And = 35-60%



FRED C. HART ASSOCIATES, INC.

BORING NO. MW-3I

				LOG OF TEST BORING		WELL CONST.	GRAPHIC LITHO LOG
DEPTH (FT)	SAMPLE NO. AND TYPE	RECOVERY (FT)	PENETRATION RESISTANCE BLOW/FT	DESCRIPTION	REMARKS		
20		1.8		FC SAND w/ ~10% GRAVEL, POORLY SORTED, DRY, LT BRN, LOOSE & SOFT.	HNu = 0.4 OVA = 1 SL. ODOR		
		1.6		BRN F-M SAND MOD. WELL SORTED, LOOSE SOFT-FIRM. (MEDIUM STIFF)			
		1.9		F-M BRN SAND w/ ~10% LO AND SO, DRY-DAMP, MOD. WELL-SORTED, ODORIFEROUS.	OVA = 4		
		1.8		SAA			
		1.5		1.2' = F-M SAND, LT BRN w/ <5% SILT, DAMP, MOD-WELL-SORTED. 0.3' = GRAVEL w/ VC SAND, BROWN, DAMP.	OVA = 3.2		
30		2.0		0.9' = M-F BRN SAND, w/SOME SILT, DAMP. MOD. WELL-SORTED. 1.1' = GRAVEL w/ SAND SILT AND CLAY, ORANGE-LT. BRN DAMP, & POORLY SORTED.	HNu = 1.2 OVA = 2.0		
		1.5		0.5' = F-M SAND, BROWN, SOFT. 0.8' = GRAVEL w/ SAND AND - DAMP. 0.2' = M-C SAND, LOOSE, DRY.	HNu = 1.2 OVA = 1.0 SL. ODOR.		
		1.8		1.6' = F-M SAND, LOOSE, SOFT, DRY-DAMP 0.2' = C SAND AND GRAVEL LAYER	OVA = 1		
		1.8		F SAND, TAN w/ SILT & w/ DEPTH, SOFT, DAMP.	OVA = 1.6		
		1.7		F-M SAND, LT BRN, WELL-SORTED, DRY-DAMP, SOFT - LOOSE.			
40		1.7		SAA			
		1.3		SAA	OVA = 0.6		
		1.8		SAA	HNu = 1		
		2		SAA			
		1.6		SAA			



FRED C. HART ASSOCIATES, INC.

BORING NO. MW-31

LOG OF TEST BORING

WELL CONST.

GRAPHIC LITHO LOG

DEPTH (FT)	SAMPLE NO. AND TYPE	RECOVERY (FT)	PENETRATION RESISTANCE BLOWS/FT	DESCRIPTION	REMARKS
50		1.7		M-C BRN SAND w/SOME GRAVEL ↑ w/DEPTH, MOIST.	
		2.0		SAA	
		1.5		F-VC BRN SAND w/GRAVEL ↑ w/DEPTH, V POORLY SORTED, DAMP.	
		0.8		M-C BRN SAND w/VC SAND AND PEBBLES, LOOSE, V. POORLY SORTED, MOIST.	
60		1.3		M-VC SAND w/SOME GRAVEL AND PEBBLES, POORLY SORTED, MOIST.	
		1.2		SAA	OA = 0.4
		0.2		SAA	
		1.5		SAA, DAMP	
		1.2		M-VC SAND w/SOME GRAVEL, MOIST, SOME F SAND AND SILT (K576)	
		1.1		M-VC SAND w/SOME GRAVEL, MOIST.	
70		1.1		M-VC SAND w/SOME GRAVEL, LOOSE SOME F SAND ↑ w/DEPTH.	
		0.65		M-VC SAND w/SOME GRAVEL, MOIST.	HNu = 0.4 SL ODOR
		1		SAA	HNu = 1.0
		1.1		M-C SAND w/SOME FINES ↑ w/DEPTH, LOOSE, DAMP.	
		1.2		SAA w/ LITTLE GRAVEL.	HNu = 0.2
80		1.2			



FRED C. HART ASSOCIATES, INC.

BORING NO. MW-3I

		LOG OF TEST BORING		WELL CONST.	GRAPHIC LITHO LOG
DEPTH (FT)	SAMPLE NO. AND TYPE	RECOVERY (FT)	DESCRIPTION	REMARKS	
80		1.4	M-C SAND w/ SOME FINE, DRY-DAMP, LOOSE.		
		1.2	F-M-C SAND, <5% GRAVEL, DAMP.		
		1.3	F-M SAND, LT BRN, SOME SILT, WELL-SORTED, DAMP, MEDIUM DENSE, SO	HNu = 1	
		1.5	SAA	HNu = 0.4	
		1	SAA		
90		2	SAA	HNu = 0.2 CVA = 0.4	
		2	SAA	HNu = 0.2	
	SPOSA 74-96	1.9	0.6' SAA, SATURATED. 0.5' BROWN-ORANGE CLAY w/C SAND AND GRAVEL, HARD, DENSE 0.8' SAA BUT GREY.		
		1	GRAY-BRN CLAY w/ LITTLE C SAND, HARD, DENSE, DRY, STICKY-PLASTIC.		
		0.5	SAA	HNu = 0.2	
100		1.7	SAA	'SHALE BLOSSOM' COLLECTS @ SURFACE	
		1.3	SAA		
		1.9	SAA	HNu = 0.8	
		0			
110		NA	F SILTY SAND, ORANGE-BRN, MOIST, WELL-SORTED, MEDIUM DENSE, MED STIFF		



FRED C. HART ASSOCIATES, INC.

BORING NO. MW-3I

		LOG OF TEST BORING		WELL CONST.	GRAPHIC LITHO LOG
DEPTH (FT)	SAMPLE NO. AND TYPE	RECOVERY (FT)	PENETRATION RESISTANCE BLOW/FT	DESCRIPTION	REMARKS
110		1.5		1' SAND, CLAY, PEBBLES (TILL) .5' M SILTY SAND, BRN.	H _{Nu} = 0.5
		1.8		3" C SAND 6" BRN SILT (TILL) 2" M SAND 8" F SILTY TILL	H _{Nu} = 1
		1.8		3" SILT, SAND, AND GRAVEL (TILL) 3" GREY CLAY 7" RED-BROWN F SAND 2" BROWN M SAND (OVA=5) 3" LT CLAY	
		1.1		2" M-C SAND 2" CLAY 10" M-C SAND	H _{Nu} = 0.5 OVA = 5.5
		1.5		M-C SAND	
120		1.3		M-VC SAND w/ SOME GRAVEL, MOIST, POORLY SORTED.	H _{Nu} = 1.4 OVA = 45.0
		1		SAA	OVA = 45.0
		1.4		SAA	H _{Nu} = 1.2 OVA = 95
		1.2		SAA	OVA = 75.0
		.9		F-M SAND, DAMP, DENSE	OVA = 58.0
130		1.4		SAA	OVA = 210.0
		.9		F-C SAND, DAMP, DENSE	OVA = 280
		1		SAA	OVA = 500.0
		.9		M-VC SAND AND GRAVEL (< 2mm φ) DAMP	OVA = 140
140		0.5		M-VC SAND w/ SOME GRAVEL, MOST	H _{Nu} = 85.0 OVA = 390



FRED C. HART ASSOCIATES, INC.

BORING NO. MW-3I

LOG OF TEST BORING

WELL CONST.
GRAPHIC LITHO LOG

DEPTH (FT)
SAMPLE NO. AND TYPE
RECOVERY (FT)
PENETRATION RESISTANCE BLOW/FT

DESCRIPTION

REMARKS

140		.9	M-C SAND w/SOME GRAVEL (< 3cm Ø) MOIST	H _N = 200.0 O _V A = 140.0
		.6	VC SAND, GRAVEL UP TO 4 cm MOIST - WET.	O _V A = 19.0
		.5	SILT CLAY AND VC SAND w/GRAVEL MOIST - WET.	O _V A = 30.0
		.5	VC SAND w/GRAVEL MOIST - WET	O _V A = 56.0
		.5	M-VC SAND w/GRAVEL (< 4cm Ø), MOIST.	O _V A = 19.0
150		1.6	VC SAND w/GRAVEL, WET	
155				
		0.2	SAA	H _N = 1.2 O _V A = 0.4
157				
160				
		.8	GRAVEL AND VC SAND, SATURATED, LOOSE	
162				
165				
		.5	M-VC SAND AND GRAVEL (< 2.5cm Ø) w/LITTLE SILT AND CLAY, SATURATED	
167				



FRED C. HART ASSOCIATES, INC.

BORING NO. MW-3I

LOG OF TEST BORING				WELL CONST.	GRAPHIC LITHO LOG
DEPTH (FT)	SAMPLE NO. AND TYPE	RECOVERY (FT)	PENETRATION RESISTANCE BLOW/FT		
170	1.7			F-M SAND, NET, LOOSE	OVA=20.0
				T.D. = 172'	
				50 - soft 70 - non-plastic 10 - loose 5 - sticky p - plastic	



FRED C. HART ASSOCIATES, INC.

TEST BORING LOG

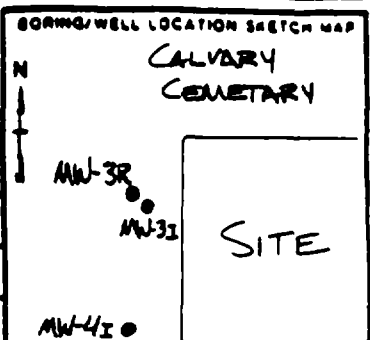

BORING NO. MW-3R	
PROJECT NO. NAME 00615-00-00002-02 / CRC	LOCATION DAYTON, OH
DRILLING CONTRACTOR, DRILLER MID EASTERN GEOTECH / WADE SIBLER	
HART GEOLOGIST OFFICE JCM/CREA ME FLEMING / PGH	
DRILLING EQUIPMENT, METHOD CABLE TOOL	SIZE/TYPE OF BIT 6" TO 300'
SAMPLING METHOD SS: 5' INT. 175-300'	START, FINISH DATE 11/3/89 - 12/1/89
WELL INSTALLED? YES <input checked="" type="checkbox"/> NO <input type="checkbox"/>	CASING MAT./DIA. BLACK STEEL / 6"
SCREEN: TYPE	MAT. STAINLESS LENGTH 10' DIA. 2" SLOT SIZE 0.01
ELEVATION OF: (FT. ABOVE M.S.L.)	GROUND SURFACE TOP OF WELL CASING TOP & BOTTOM SCREEN GW SURFACE DATE
REMARKS:	

LOG OF TEST BORING					WELL CONST.	GRAPHIC LITHO LOG
DEPTH (FT)	SAMPLE NO. AND TYPE	RECOVERY (FT)	PENETRATION RESISTANCE BLOWS/FT	DESCRIPTION		
5				NO SAMPLES COLLECTED UNTIL 175' (REFER TO MW-3I BORING LOG FOR 0-175')		
10						
15						
20						

Proportions Used: Trace = 0-10%, Little = 10-20%, Some = 20-35%, And = 35-50%
 Sampling Abbreviations: SS = Split Spoon, ST = Shelby Tube, CSC = Continuous Soil Core



FRED C. HART ASSOCIATES, INC.

BORING NO. MW-3R

LOG OF TEST BORING

DEPTH (FT)
SAMPLE NO. AND TYPE
RECOVERY (FT)
PENETRATION RESIST-
ANCE BLOW/FT

DESCRIPTION

REMARKS

WELL CONST.

GRAPHIC
LITHO LOG

175

177	1.4	VC SAND AND GRAVEL ($\leq 3\phi$); WET, LOOSE.	HNu = 0
180			
182	.9	VC SAND AND GRAVEL, LOOSE	HNu = 0
185			
187	1.9	VF GRAY SAND, WET, PLASTIC W/ LITTLE GRAVEL ($\leq 1\phi$)	HNu = 0.4
190			
192	1.5	F-M GRAY SAND, WET, NO GRAVEL.	HNu = 0
195			
197	1.5	F-M GRAY SAND, WET, NO GRAVEL	HNu = 0
200			
202	1.8	M GRAY SAND, WET, NO GRAVEL	HNu = 0



FRED C. HART ASSOCIATES, INC.

BORING NO. MW-3R

LOG OF TEST BORING

DEPTH (FT)	SAMPLE NO. AND TYPE	RECOVERY (FT)	PENETRATION RESISTANCE (BLows/FT)	DESCRIPTION	REMARKS	WELL CONST.	GRAPHIC LITHO LOG
205 207	.7			VC SAND AND GRAVEL ($\leq 2cm \phi$), WET, LOOSE.	HNu = 0		
210							
212	1.2			C SAND - GRAVEL, SOME M SAND, WET, LOOSE.	HNu = 0		
215							
217	.5			M-C GRAY SAND AND GRAVEL, WET, LOOSE.	HNu = 0 SPDN REFUSAL @ 1.0'		
220							
222	.4			CLAY AND COARSE SAND + GRAVEL, MOIST, TIGHT, FIRM. (HARD PAN/TILL)	HNu = 0 SPDN REFUSAL @ 1.0'		
225							
227	2			F.M BROWN SAND, TR SILT, TIGHT, SATURATED.	HNu = 0 VOR'S COLLECTED		
230							
232	1			BROWN MCF SAND, 30% GRAVEL, SUB-ROUNDED $< 1cm \phi$, POORLY SORTED, SATURATED $< 10\%$ FINES	HNu = 0		



FRED C. HART ASSOCIATES, INC.

BORING NO. MW-3R

LOG OF TEST BORING

235

DEPTH (FT)	SAMPLE NO. AND TYPE	RECOVERY (FT)	PENETRATION RESISTANCE BLOW/FT	DESCRIPTION	REMARKS	WELL CONST.	GRAPHIC LITHO LOG
237	2			BROWN FM SAND + SILT, SATURATED	HNu = 0		
242	1.3			BROWN FM SAND, 20% SILT, TR CLAY, SATURATED	HNu = 0		
249	1.5			BROWN AND RED-BROWN SAND MCF SAND AND GRAVEL, ROUNDED TO SUB ROUNDED. 50% < 0.5cm, 20% < 1cm; 20% SILT, SATURATED.	HNu = 0		
252	1.5			BROWN FM GRAVEL (< 0.5cm Ø) AND MF SAND, 10% SILT, POORLY SORTED, SATURATED.	HNu < 0 0% LCL 21% O ₂ 0 ppm H ₂ S		
257	.5			LT BROWN RED BROWN TILL, GRAVEL + SAND IN SILT CLAY MATRIX	HNu = 0		
262	.7			BROWN GRAVEL, SAND IN SILT, LITTLE CLAY - GRAVEL SUBROUNDED - ANGULAR TO 1cm Ø, TIGHT SATVRATED	HNu = 0 VOA's COLLECTED		



FRED C. HART ASSOCIATES, INC.

BORING NO. MW-3R

LOG OF TEST BORING

265

DEPTH (FT)	SAMPLE NO. AND TYPE	RECOVERY (FT)	PENETRATION RESISTANCE BLOW/FT	DESCRIPTION	REMARKS	WELL CONST.	GRAPHIC LITHO LOG
267	1			SILT AND F SAND W/LARGE ANGULAR GRAVEL TO 2CM Ø (GREEN R. CHIPS), SATURATED LOOSE	VOA'S COLLECTED		
270							
272				BROWN M-C SAND AND GRAVEL, ANG. TO SUB, 20% FINES APPEARS TO BE TILL AND SAND (LEUSE OF MC SAND TR FINES NO GRAVEL, LOOSE)	H _{Nu} = 0		
275							
277	3			CRUSHED ROCK, BROWN ANGULAR GRAVEL < 1CM; W/D MAT'L (GRAVEL) MAKES UP MATRIX W/FINES (SILT + CLAY) TR SAND DAMP, TIGHT.	H _{Nu} = 0		
280							
282	9			MCF GRAVEL, ROUNDED TO LARGER ANGULAR PIECES. C-M SAND, 10% FINES, TIGHT, MOIST	H _{Nu} BATTERY LOW		
285							
287				C MF GRAVEL AND CM SAND, 20% SILT, SATURATED, LOOSE, GRAVEL SUB ROUNDED TO SUBANGULAR, BROWN. (<1cm)	VOA'S COLLECTED		
290							
292				C MF GRAVEL + CM SAND, 10% SILT SATURATED, LOOSE, <0.5CM Ø SUB ANG. TO SUB ROUNDED, BROWN.			



FRED C. HART ASSOCIATES, INC.

BORING NO. MW-312

LOG OF TEST BORING

295

DEPTH (FT)
SAMPLE NO. AND TYPE
RECOVERY (FT)
PENETRATION RESISTANCE
BLOWS/FT

DESCRIPTION

REMARKS

WELL CONST.

GRAPHIC
LITHO LOG

DEPTH (FT)	SAMPLE NO. AND TYPE	RECOVERY (FT)	PENETRATION RESISTANCE BLOWS/FT	DESCRIPTION	REMARKS	WELL CONST.	GRAPHIC LITHO LOG
297	.3			C/M SAND, ANGULAR GRAVEL, LOOSE, SAT'D. 30% FINES w/ 4/16" GRAVEL + C/M SAND.	CLAY @ ~ 298'		
298				GRAY BLUE TIGHT CLAY TO WEATHERED SHALE (DK.)			
300	.2						
				T.D. = 300'			



FRED C. HART ASSOCIATES, INC.

TEST BORING LOG

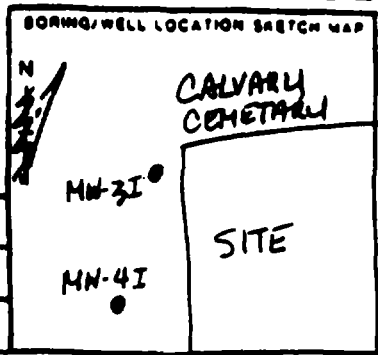

BORING NO. MN-4I		PROJECT NO. NAME 00615-00-00002-02 / CRC		LOCATION DAYTON, OH	
DRILLING CONTRACTOR, DRILLER MID-EASTERN GEOTECH / Bill and Wade Sigler				HART GEOLOGIST OFFICE Boyer, McIver, Shields - Pittsburgh	
DRILLING EQUIPMENT, METHOD CABLE TOOL		SIZE/TYPE OF BIT NOMINAL 6"		SAMPLING METHOD 2" CONT. SS	START, FINISH DATE 8/11/87-8/25/87
WELL INSTALLED? YES <input checked="" type="checkbox"/> NO <input type="checkbox"/>	CASING MAT./DIA.	SCREEN TYPE	MAT. STAINLESS LENGTH 10' DIA. 2'		SLOT SIZE
ELEVATION OF GROUND SURFACE (FT. ABOVE M.S.L.)		TOP OF WELL CASING 158.168'		TOP & BOTTOM SCREEN 160'	GW SURFACE DATE
REMARKS:					

LOG OF TEST BORING

DEPTH (FT)	SAMPLE NO. AND TYPE	RECOVERY (FT)	PENETRATION RESISTANCE BLOWS/FT	DESCRIPTION	REMARKS	WELL CONST.	GRAPHIC LITHO LOG
0				BRN SILT AND GRAVEL, LOOSE, SOFT, DRY			
0.5				SILT, SAND, GRAVEL - NO SAMPLE TAKEN	OVA = 1.0 ppm		
1.4				1'- V.C. SAND W/ SOME GRAVEL - DAMP 0.4'- WHITE, BRN SILTY CLAY	OVA = 4.0 ppm		
1.3				0.6'- M-C SAND W/ SOME GRAVEL, BRN 0.7'- F-M SAND, DRY-DAMP	OVA = 1.0 ppm		
1.6				F-M SAND, LOOSE, DRY, BRN	OVA = 1.4 ppm		
1.2				F-M SAND LOOSE, DRY	OVA = 3.0 ppm		
1.0				F-M LT. BRN SAND W/ ≈ 2" GRAVEL NO ODOR			
1.0				F-M BRN SAND INTERSPERSED GRAVEL NO ODOR			
1.0				F-M SAND, DRY, DAMP - 0.6' GRAVEL - 0.6' REFUSAL @ 18"			
0.5				M-C SAND AND GRAVEL, LOOSE	OVA = 2.0 ppm		

20 Proportions Used: Trace = 0-10%, Little = 10-20%, Some = 20-35%, And = 35-60%
 Sampling Abbreviations: SS = Split Spoon, ST = Shelby Tube, CSC = Continuous Soil Core



FRED C. HART ASSOCIATES, INC.

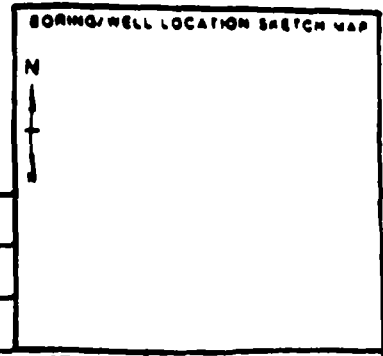

TEST BORING LOG

BORING NO. MW-4I		PROJECT NO. NAME 00615-00-00007-07 / CRC			LOCATION DAYTON, OH	
DRILLING CONTRACTOR, DRILLER MID EASTERN GEOTECH / BILL AND WADE SIGLER		HART GEOLOGIST, OFFICE SHIELDS / MCCREA				
DRILLING EQUIPMENT, METHOD		SIZE / TYPE OF BIT		SAMPLING METHOD	START, FINISH DATE	
WELL INSTALLED? YES <input checked="" type="checkbox"/> NO <input type="checkbox"/>	CASING MAT. / DIA.	SCREEN: TYPE	MAT.	LENGTH	DIA.	SLOT SIZE
ELEVATION OF: (FT. ABOVE M.S.L.)	GROUND SURFACE	TOP OF WELL CASING	TOP & BOTTOM SCREEN	GW SURFACE	DATE	REMARKS:

LOG OF TEST BORING							WELL CONST.	GRAPHIC LITHO LOG
DEPTH (FT)	SAMPLE NO. AND TYPE	RECOVERY (FT)	PENETRATION RESISTANCE BLOWS/FT	DESCRIPTION	REMARKS			
20	1.0			C. SAND AND GRAVEL - LOOSE	OVA = 25 ppm			
	0.8			F-VC SAND AND GRAVEL, POORLY SORTED LOOSE DAMP - TILL(?)	OVA = 0.4 ppm			
5	1.0			F-C SAND AND GRAVEL, BRN. POORLY SORTED NO ODOR				
	1.5			M-C BRN SAND NO ODOR				
	1.0			M SAND; LT BRN, WELL SORTED NO ODOR				
30	1.0			F SAND WITH SOME SILT, BRN. WELL SORTED				
	1.5			F-M SAND LT. BRN, NO ODOR DAMP TO MOIST	OVA = 0.5 ppm			
15	1.5			SAA				
	1.5			M-C SAND BRN, DAMP, NO ODOR				
	1.0			M-C SAND, BRN, AND GRAVEL	OVA = 2.5 ppm			

40 Proportions Used: Trace = 0-10%, Little = 10-20%, Some = 20-35%, And = 35-50%
 Sampling Abbreviations: SS = Spill Spoon, ST = Shelby Tube, CSC = Continuous Soil Core



FRED C. HART ASSOCIATES, INC.

TEST BORING LOG

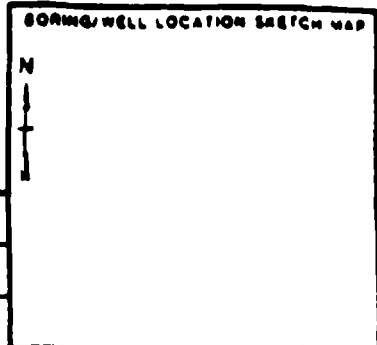

BORING NO. MW-4 I		PROJECT NO. NAME 00615-00-00002-02 / CRC		LOCATION DALTON OH	
DRILLING CONTRACTOR, DRILLER WID-EASTERN GEOTECH / BILL AND WADE SIGLER		HART GEOLOGIST, OFFICE SHIELDS / MCCREA			
DRILLING EQUIPMENT, METHOD		SIZE/TYPE OF BIT		SAMPLING METHOD	START, FINISH DATE
WELL INSTALLED? YES <input type="checkbox"/> NO <input type="checkbox"/>	CASING MAT./DIA.	SCREEN: TYPE	MAT.	LENGTH	DIA.
ELEVATION OF: (FT. ABOVE M.S.L.)	GROUND SURFACE	TOP OF WELL CASING	TOP & BOTTOM SCREEN	GW SURFACE	DATE
REMARKS:					

DEPTH (FT)		SAMPLE NO. AND TYPE		RECOVERY (FT)		PENETRATION RESIST- ANCE BLOWS/FT		LOG OF TEST BORING		WELL CONST.	GRAPHIC LITHO LOG	
								DESCRIPTION		REMARKS		
40			1-φ						F-M. SAND AND GRAVEL	OVA = 4.φ		
			1-φ						F-VC BRN SAND AND GRAVEL, LOOSE, POORLY SORTED, DAMP	OVA = 2.5		
	5		φ8						M-VC SAND AND GRAVEL, LOOSE, POORLY SORTED, DAMP	OVA = 7.5		
			1-φ						SAA	OVA = 2.φ		
			φ4						SAA, larger diameter gravel	OVA = φ		
50	10		φ9						F-VC SAND AND GRAVEL	OVA = 1.5 ppm		
			1-φ						M-C SAND AND GRAVEL, NO ODOR, DAMP	OVA = 1.φ ppm		
	15		φ.4						SAA - GRAVEL (≤ 3.0 cm)	OVA = 1.2		
			φ.5						SAA			
			φ.5						SAA			

60 Proportions Used: Trace = 0-10%, Little = 10-20%, Some = 20-35%, And = 35-50%
 Sampling Abbreviations: SS = Split Spoon, ST = Shelby Tube, CSC = Continuous Soil Core

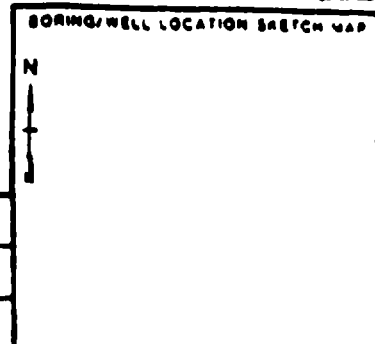

TEST BORING LOG

BORING NO. MW-4E				
PROJECT NO. NAME 00615-00-00002-02/CSC		LOCATION DAYTON, OH		
DRILLING CONTRACTOR, DRILLER MID-EASTERN GEOTECH/BILL AND WADE SIGLER				
HART GEOLOGIST, OFFICE SHIELDS/MCCREA				
DRILLING EQUIPMENT, METHOD		SIZE/TYPE OF BIT		SAMPLING METHOD
START, FINISH DATE				
WELL INSTALLED? YES <input type="checkbox"/> NO <input type="checkbox"/>	CASING MAT./DIA.	SCREEN: TYPE	MAT.	LENGTH
				DIA.
				SLOT SIZE
ELEVATION OF: (FT. ABOVE M.S.L.)		GROUND SURFACE	TOP OF WELL CASING	TOP & BOTTOM SCREEN
				GW SURFACE
				DATE
REMARKS:				

		LOG OF TEST BORING			WELL CONST.	GRAPHIC LITHO LOG
DEPTH (FT)	SAMPLE NO. AND TYPE	RECOVERY (FT)	PENETRATION RESIST- ANCE BLOWS/FT	DESCRIPTION		
60	SB004 02-12-12	1.0		GRAVEL AND M-VC SAND, DAMP, FAIRLY TIGHT	OVA = 24.0	
	SB004 02-12-12	1.0		GRAVEL (<3cm) w/ SOME F-M SAND	OVA = 20.0	
5		1.0		M-C SAND AND GRAVEL, LOOSE, DAMP, MOIST	OVA = 4.0	
		1.0		M-C SAND AND GRAVEL, LT. BRN, TIGHT, DAMP	OVA = 5ppm	
70		0.5		BROKEN, FRAGMENT ROCK, GRAVEL SAND, SILT, AND CLAY (TILL) POORLY SORTED MOIST		
		0.5		SAA	4.0 OVA	
		0.9		F-VC SAND, MOIST, FAIRLY TIGHT		
15		1.0		M-C SAND, MOIST w/ 2" GRAVEL LAYER FAIRLY TIGHT		
		1.0		F-VC SAND, GRAVEL AND CLAY V. MOIST		
		1.0		0.2' - SILT AND GRAVEL, MOIST 0.8' - F-M SAND, MOIST		

80 Proportions Used: Trace = 0-10%, Little = 10-20%, Some = 20-35%, And = 35-50%
 Sampling Abbreviations: SS = Spill Spoon, ST = Shelby Tube, CSC = Continuous Soil Core



TEST BORING LOG

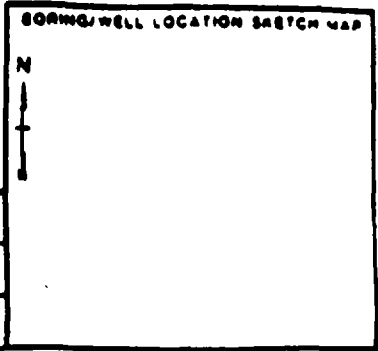

BORING NO. MN-4E		PROJECT NO. NAME 00615-00-00002-02 / CLS		LOCATION DAVTON, OH	
DRILLING CONTRACTOR, DRILLER MIDEASTERN GEOTECH				HART GEOLOGIST OFFICE SHIELDS, MCCLEA	
DRILLING EQUIPMENT, METHOD		SIZE/TYPE OF BIT		SAMPLING METHOD	
WELL INSTALLED? YES <input type="checkbox"/> NO <input type="checkbox"/>		CASING MAT./DIA.		SCREEN: TYPE MAT. LENGTH DIA. SLOT SIZE	
ELEVATION OF: GROUND SURFACE		TOP OF WELL CASING		TOP & BOTTOM SCREEN GW SURFACE DATE	
REMARKS:					

LOG OF TEST BORING					WELL CONST.	GRAPHIC LITHO LOG
DEPTH (FT)	SAMPLE NO. AND TYPE	RECOVERY (FT)	PENETRATION RESISTANCE BLOWS/FT	DESCRIPTION		
80	1.0			F-M SAND AND SILT W/ SOME GRAVEL CLAY AT BASE, DAMP		
	1.2			F-M SAND, LOOSE, V. MOIST		
5	15			F-M SAND, LOOSE, V. MOIST, RUST COLORED AT BASE		
	1.8			GRAY BRN SILTY CLAY, SOFT, DAMP	OVA = 3.0	
	1.7			SAA	OVA = 0	
70	1.2			0.8' GRAY BRN SILTY CLAY W/ V.C. SAND AND GRAVEL DRU 0.4' ORANGE BRN F SAND AND GRAVEL	OVA = 0.5	
	1.0			ORANGE BRN F-M SAND W/ SOME GRAVEL	OVA = 28.0	
15	1.0			BRN CLAY SILT, SAND AND GRAVEL (TILL) ODOROUS	OVA = 70.0	
	0.2			SAA	OVA = 100.0	
100	1.2			SAA w/ less clay + silt	OVA = 560	

Proportions Used: Trace = 0-10%, Little = 10-20%, Some = 20-35%, And = 35-50%
 Sampling Abbreviations: SS = Split Spoon, ST = Shelby Tube, CSC = Continuous Soil Core



FRED C. HART ASSOCIATES, INC.

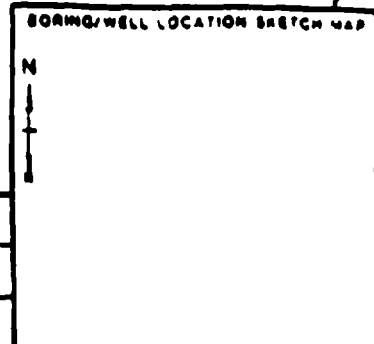

TEST BORING LOG

BORING NO. MW-41		PROJECT NO. NAME 00615-00-00002-02 / CRC		LOCATION DAULTON, OH	
DRILLING CONTRACTOR, DRILLER MID-EASTERN GEOTECH / BILL AND WADE SIGLER					
HART GEOLOGIST, OFFICE SHIELDS / MCCREA					
DRILLING EQUIPMENT, METHOD CABLE TOOL			SIZE / TYPE OF BIT		SAMPLING METHOD
WELL INSTALLED? YES <input checked="" type="checkbox"/> NO <input type="checkbox"/>		CASING MAT. / DIA.		SCREEN: TYPE MAT. LENGTH DIA. SLOT SIZE	
ELEVATION OF: (FT. ABOVE M.S.L.)		GROUND SURFACE		TOP OF WELL CASING	
		TOP & BOTTOM SCREEN		GW SURFACE DATE	
REMARKS:					

DEPTH (FT)		SAMPLE NO. AND TYPE		RECOVERY (FT)		PENETRATION RESIST- ANCE BLOWS/FT		LOG OF TEST BORING		WELL CONST.	GRAPHIC LITHO LOG
								DESCRIPTION	REMARKS		
0		SB006A VOC	1.0					M-VC SAND W/ LITTLE GRAVEL	OVA = 37.0		
		SB006B FITTING VOC	1.0					M-VC SAND W/ FRAGMENTED ROCKS AT BASE	OVA = 18.0		
5		SB006A FITTING VOC	1.0					F-VC SAND W/ LITTLE GRAVEL, MOIST	OVA = 78.0		
			0.5					F-VC SAND, W/ LITTLE GRAVEL, MOIST	HNU = 0.8		
			0.4					F-VC SAND, SILT, CLAY, W/ LT GRAVEL, DAMP			
10			0.5					GRAVEL, AND LT GRAY & SILTY CLAY AT BASE, DAMP			
			0.5					LT. BRN MED SAND W/ LITTLE GRAVEL DAMP			
15			1.0					LT BRN M SAND W/ SOME GRAVEL, WELL SORTED,			
		SB006A VOC	0.8					F-M SAND, BRN, DRY-DAMP, LOOSE	OVA = 12.0		
			0.7					0.4' SAA 0.3' CLAY, SILT, SAND GRAVEL	OVA = 8.0		

Proportions Used: Trace = 0-10%, Little = 10-20%, Some = 20-35%, And = 35-50%
 Sampling Abbreviations: SS = Split Spoon, ST = Shelby Tube, CSC = Continuous Soil Core



FRED C. HART ASSOCIATES, INC.

TEST BORING LOG

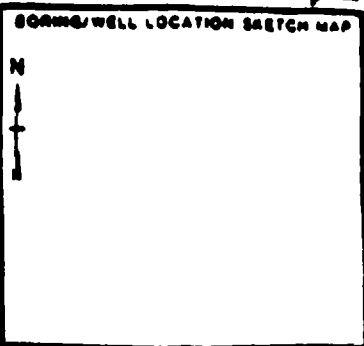

BORING NO. MW-4I

PROJECT NO. NAME 00615-00-00007-02 / CCR LOCATION DAYTON, OH

DRILLING CONTRACTOR, DRILLER MID-EASTERN GEOTECH

HART GEOLOGIST, OFFICE

DRILLING EQUIPMENT, METHOD SIZE/TYPE OF BIT SAMPLING METHOD START, FINISH DATE

WELL INSTALLED? YES NO CASING MAT./DIA. SCREEN: TYPE MAT. LENGTH DIA. SLOT SIZE

ELEVATION OF: GROUND SURFACE TOP OF WELL CASING TOP & BOTTOM SCREEN GW SURFACE DATE (FT. ABOVE M.S.L.)

REMARKS:

DEPTH (FT)		SAMPLE NO. AND TYPE		RECOVERY (FT)		PENETRATION RESISTANCE BLOWS/FT		LOG OF TEST BORING		WELL CONST.	GRAPHIC LITHO LOG
		DESCRIPTION		REMARKS							
120			SAA		OVA = 30.0 HNU = 0						
			SAA		OVA = 100.0 HNU = 0						
			SAA		OVA = 22.0						
130			M-C SAND AND GRAVEL, LT. BRN. DAMP TIGHTLY PACKED		HNU = 0						
			SAA								
140											

Proportions Used: Trace = 0-10%, Little = 10-20%, Some = 20-35%, And = 35-50%

Sampling Abbreviations: SS = Split Spoon, ST = Shelby Tube, CSC = Continuous Soil Core



FRED C. HART ASSOCIATES, INC.

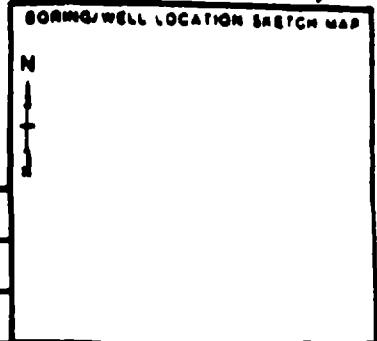

TEST BORING LOG

BORING NO. MW-4E			
PROJECT NO., NAME 00615-00-00002-02 / CRC		LOCATION DAVTON, OH	
DRILLING CONTRACTOR, DRILLER MIDEASTERN GEOTECH			
HART GEOLOGIST, OFFICE SHIELDS / MCCREA			
DRILLING EQUIPMENT, METHOD		SIZE / TYPE OF BIT	SAMPLING METHOD
WELL INSTALLED? YES <input type="checkbox"/> NO <input type="checkbox"/>		CASING MAT./DIA.	SCREEN: TYPE MAT. LENGTH DIA. SLOT SIZE
ELEVATION OF: GROUND SURFACE TOP OF WELL CASING TOP & BOTTOM SCREEN GW SURFACE DATE		(FT. ABOVE M.S.L.)	
REMARKS:			

LOG OF TEST BORING				WELL CONST.	GRAPHIC LITHO LOG
DEPTH (FT)	SAMPLE NO. AND TYPE	RECOVERY (FT)	PENETRATION RESISTANCE BLOWS/FT		
40	1.5			SAA	
	1.0			SAA	H _{Nu} = 0.5
150	1.5			SILTY CLAY AND FINE SAND W/ GRAVEL LT. BRN, MOIST	H _{Nu} = 1.0
	1.0			0.5'-F. SAND AND GRAVEL, LT BRN MOIST 0.5'-BLACKISH BRN, ORGANIC-RICH "SHALE-LIKE" SEDIMENT DECREASING IN OM AT BASE	H _{Nu} = 4.0
160					

Proportions Used: Trace = 0-10%, Little = 10-20%, Some = 20-35%, And = 35-50%
 Sampling Abbreviations: SS = Split Spoon, ST = Shelby Tube, CSC = Continuous Soil Core



FRED C. HART ASSOCIATES, INC.

TEST BORING LOG

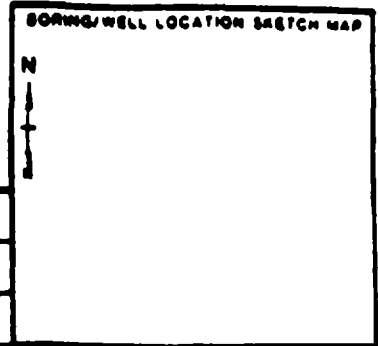

BORING NO. MW-4-E		PROJECT NO., NAME 00045-00-0000202 / CRC		LOCATION DALTON, OH	
DRILLING CONTRACTOR, DRILLER MIDWESTERN GEOTECH		HART GEOLOGIST, OFFICE SHIELDS/MCCREA		DRILLING EQUIPMENT, METHOD CABLE TOOL	
WELL INSTALLED? YES <input checked="" type="checkbox"/> NO <input type="checkbox"/>		CASING MAT./DIA.		SCREEN: TYPE MAT. LENGTH DIA. SLOT SIZE	
ELEVATION OF: (FT. ABOVE M.S.L.)		GROUND SURFACE		TOP OF WELL CASING	
REMARKS:		TOP & BOTTOM SCREEN		GW SURFACE DATE	

DEPTH (FT)	SAMPLE NO. AND TYPE	RECOVERY (FT)	PENETRATION RESISTANCE BLOWS/FT	LOG OF TEST BORING		WELL CONST.	GRAPHIC LITHO LOG
				DESCRIPTION	REMARKS		
160	2004-104	1.5'		LT. BRN GRAVEL W/ F-M SAND, SATURATED OVA = ϕ	160'		
5		1.5'		SAA			
70		ϕ		SAA END DRILL			
15				TD = 170' SCREEN INTERVAL = 158' - 168'			
20							

Proportions Used: Trace = 0-10%, Little = 10-20%, Some = 20-35%, And = 35-50%
 Sampling Abbreviations: SS = Spill Spoon, ST = Shelby Tube, CSC = Continuous Soil Core



FRED C. HART ASSOCIATES, INC.

TEST BORING LOG

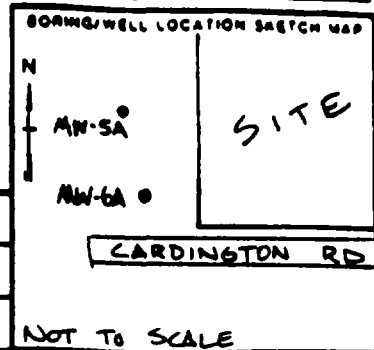

BORING NO. MW-5A

PROJECT NO. NAME 00615-00-00002-02 LOCATION DAYTON, OH

DRILLING CONTRACTOR, DRILLER MID-EASTERN GEOTECH/BILL AND WADE SIELER

HART GEOLOGIST OFFICE DON SHIELDS/PCH

DRILLING EQUIPMENT, METHOD CABLE TOOL SIZE/TYPE OF BIT NORMAL 6" Ø / CABLE TOOL SAMPLING METHOD 2' CONT. SS START, FINISH DATE 7/24/89-7/27/89

WELL INSTALLED? YES NO CASING MAT./DIA. SCREEN: TYPE MAT. STAINLESS LENGTH 10' DIA. 2" SLOT SIZE 0.01

ELEVATION OF: GROUND SURFACE TOP OF WELL CASING TOP & BOTTOM SCREEN GW SURFACE DATE

REMARKS:

LOG OF TEST BORING				WELL CONST.	GRAPHIC LITHO LOG
DEPTH (FT)	SAMPLE NO. AND TYPE	RECOVERY (FT)	PENETRATION RESISTANCE BLOWS/FT		
1.5				LT. BRN C G SAND AND GRAVEL	
1.5				SAA	
5				SAA @ TOP. F-M SAND, WELL SORTED @ BOTTOM.	
1.5				F SAND, LT BRN @ TOP. CLAY AND SILT, LT BRN @ BOTTOM.	
10				M-C SAND, LT BRN, POORLY SORTED, LOOSE.	
2				SAA	
1.8				M-C SAND, LT BROWN W/ SOME GRAVEL, POORLY SORTED. GRAVEL ↑ W/ DEPTH.	
15				M-C SAND, LT. BROWN AND GRAVEL (<1" Ø), POORLY SORTED.	
1				C SAND, LT BRN AND GRAVEL, POORLY SORTED, WET	
1.5				M-C SAND, LT BRN W/ SOME GRAVEL, POORLY SORTED, DAMP	

Proportions Used: Trace = 0-10%, Little = 10-20%, Some = 20-35%, And = 35-50%
 Sampling Abbreviations: SS = Split Spoon, ST = Shelby Tube, CSC = Continuous Soil Core



FRED C. HART ASSOCIATES, INC.

BORING NO. MN-5A

LOG OF TEST BORING

DEPTH (FT)	SAMPLE NO. AND TYPE	RECOVERY (FT)	PENETRATION RESISTANCE BLOW/FT	DESCRIPTION	REMARKS	WELL CONST.	GRAPHIC LITHO LOG
20	2			SAA, DRY.			
	1			M-C SAND, LT. BRN, W/ GRAVEL, POORLY SORTED @ TOP. F-M SAND, WELL-SORT, DRY @ BOTTOM.			
	2			M-C SAND, LT BRN @ TOP. F SAND @ BOTTOM.			
	1			M-C SAND, LT. BROWN, WELL-SORTED			
	1.5			F-M SAND, LT. BRN, WELL-SORTED.			
30	1.8			SAA			
	1.5			SAA			
	1.5			SAA			
	2			M-C SAND, LT. BRN.			
	1.5			M-C SAND, LT. BRN, W/ SOME GRAVEL			
40	1.5			M-C SAND, LT BRN, FAIRLY-SORTED			
	1			SILTY CLAY AND GRAVEL, LT BROWN, POORLY SORTED @ TOP. M-C SAND, LT BRN @ BOTTOM.			
	1			F-M SAND W/ SOME SILTY CLAY, LT BRN, DAMP.			
	2			M-C SAND @ TOP. F SAND, MOIST @ BOTTOM.			
	2			F-M SAND, MOIST			
50							



FRED C. HART ASSOCIATES, INC.

BORING NO. MW-5A

LOG OF TEST BORING

DEPTH (FT)		SAMPLE NO. AND TYPE		RECOVERY (FT)		PENETRATION RESISTANCE BLOW/FT		DESCRIPTION	REMARKS	WELL CONST.	GRAPHIC LOG
50		2'									
		2						SAA			
		2						SAA, NET			
		2						SAA			
		2						SAA			
60		2						SAA			
		2						M-C SAND, LT BRN @ TOP. RUST COLOR @ BOTTOM. WET; F-M SAND, LT BRN @ BOTTOM			
		1.8						CLAY, LT GREY, W/ SOME GRAVEL, SOME SILT, PLASTIC, DRY, V. POORLY SORTED.			
								T.D. = 66'			



FRED C. HART ASSOCIATES, INC.

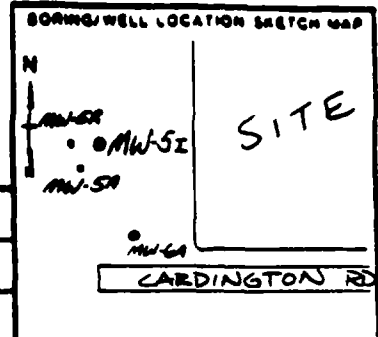

TEST BORING LOG

BORING NO. MW-5Z

PROJECT NO. NAME 00615-00-000021 CRC LOCATION DAYTON, OH

DRILLING CONTRACTOR, DRILLER MIDEASTERN GEOTECH / BILL SIGLER, TY WALKER

HART GEOLOGIST, OFFICE ME FLEMING / P&H

DRILLING EQUIPMENT, METHOD CABLE TOOL SIZE/TYPE OF BIT 6" P SAMPLING METHOD NONE * START, FINISH DATE 10/30/87 - 11/3/87

WELL INSTALLED? YES NO CASING MAT./DIA. BLACK STEEL / 6" SCREEN TYPE MAT. STAINLESS LENGTH 10 DIA. 2" SLOT SIZE 0.01"

ELEVATION OF: GROUND SURFACE TOP OF WELL CASING TOP & BOTTOM SCREEN GW SURFACE DATE

REMARKS:

LOG OF TEST BORING				WELL CONST.	GRAPHIC LITHO LOG	
DEPTH (FT)	SAMPLE NO. AND TYPE	RECOVERY (FT)	PENETRATION RESISTANCE BLOWS/FT			DESCRIPTION
0						* NO SAMPLES COLLECTED.
5						TOTAL DEPTH OF BORING = 130'
10						SEE MW-5A BORING LOG FOR 0-66'
15						SEE MW-5R BORING LOG FOR 66-130'
20						▽ = 120'

Proportions Used: Trace = 0-10%, Little = 10-20%, Some = 20-35%, And = 35-60%

Sampling Abbreviations: SS = Split Spoon, ST = Shelby Tube, CSC = Continuous Soil Core



FRED C. HART ASSOCIATES, INC.

TEST BORING LOG

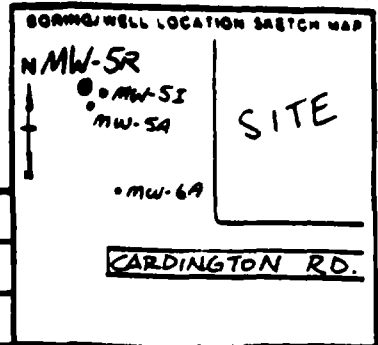

BORING NO. MW-5R		PROJECT NO. NAME 00615-00-00002.02 / CRC		LOCATION DAYTON, OHIO	
DRILLING CONTRACTOR, DRILLER MID EASTERN GEOTECH / BILL SIGLER, TY WALKER				HART GEOLOGIST, OFFICE T. ROYER / PGN	
DRILLING EQUIPMENT, METHOD CABLE TOOL		SIZE/TYPE OF BIT 0" x 70 65' 6" Ø TO 282'		SAMPLING METHOD SS	START, FINISH DATE 9/25/89 - 10/20/89
WELL INSTALLED? YES <input checked="" type="checkbox"/> NO <input type="checkbox"/>	CASING MAT./DIA. BLACK STEEL 1/6"	SCREEN TYPE	MAT. STAINLESS, LENGTH 10' DIA. 2" SLOT SIZE		
ELEVATION OF: GROUND SURFACE		TOP OF WELL CASING		TOP & BOTTOM SCREEN	GW SURFACE DATE
REMARKS:					

LOG OF TEST BORING					WELL CONST.	GRAPHIC LITHO LOG
DEPTH (FT)	SAMPLE NO. AND TYPE	RECOVERY (FT)	PENETRATION RESISTANCE BLOW/FT	DESCRIPTION		
0						
5						
10						
15						
20						
<p>NO SAMPLES COLLECTED UNTIL 65'.</p> <p>(SEE MW-5A BORING LOG FOR 0-65'.)</p>						
25						
30						
35						
40						
45						
50						
55						
60						
65						
70						
75						
80						
85						
90						
95						
100						

Proportions Used: Trace = 0-10%, Little = 10-20%, Some = 20-35%, And = 35-60%
 Sampling Abbreviations: SS = Split Spoon, ST = Shelby Tube, CSC = Continuous Soil Core



BORING NO.

MW-5R

LOG OF TEST BORING

65

DEPTH (FT)	SAMPLE NO. AND TYPE	RECOVERY (FT)	PENETRATION RESISTANCE BLOW/FT	DESCRIPTION	REMARKS	WELL CONST.	GRAPHIC LITHO LOG
67				GREY CLAY w/ TRACE GRAVEL			
69							
71	2			GREY CLAY w/ TRACE GRAVEL (VC SAND TO 2cm) v. FIRM, PLASTIC, DENSE, TILL.	HNu = 0		
75							
77	1			GREY TILL - GRAVEL AND VC SAND (2mm-2cm) w/ SILT AND CLAY (<15%) VERY LOOSE, MOIST			
80							
82	.8			C-VC BRN SAND w/ GRAVEL (50%) AND SILT, CLAY (10mm-2cm+), LOOSE SLIGHTLY ODOROUS	HNu = 0		
85							
87	2			F-M-C SAND w/ TRACE GRAVEL (<1cm) (<10%), SILT, AND CLAY (<10%), BRN, MOIST, LOOSE.	HNu = 0		
90							
92	1			SAA, EXCEPT % GRAVEL ↑ ≈ 20%, DAMP.	HNu = 17ppm VOR's COLLECTED (SB9294)		



FRED C. HART ASSOCIATES, INC.

BORING NO. MW-5R

LOG OF TEST BORING

95

DEPTH (FT)	SAMPLE NO. AND TYPE	RECOVERY (FT)	PENETRATION RESISTANCE BLOW/FT	DESCRIPTION	REMARKS	WELL CONST.	GRAPHIC LITHO LOG
97	.5			M-C BRN SAND w/ SOME VC SAND, SILT, AND CLAY (~25%), LOOSE, MOIST.	HNu = 0 COMPOSITE SAMPLE		
100							
102	1.2			F-M-C SAND w/ SOME GRAVEL (30%, <1cm) AND TRACE SILT + CLAY, MOIST	HNu = 4ppm COMPOSITE SAMPLE		
105							
107	1.0			F-M-C SAND w/ SOME GRAVEL (40%), TRACE SILT + CLAY, MOIST-V. MOIST.	HNu = 0		
110							
112	.4			C-VC SAND, BRN-WHITE w/ TRACE F SAND AND GRAVEL (5mm-50mm) MOD. WELL ROUNDED, POORLY SORTED DRY, LOOSE.	HNu = 0		
115							
117	.6			C. BRN SAND w/ GRAVEL (20%, <1cm) AND TRACE SAND, TRACE SILT AND CLAY (~15%) DAMP-DRY; LOOSE, POORLY SORTED.	HNu = 0		
120							
122	.6			GRAVEL (5mm-2cm, 60%) w/ FM SAND, SILT AND CLAY, BRN V. POORLY SORTED, ROUNDED CLAST, LOOSE, DAMP TO DRY.	HNu = 0		



BORING NO. MW-5R

LOG OF TEST BORING

125

DEPTH (FT)	SAMPLE NO. AND TYPE	RECOVERY (FT)	PENETRATION RESISTANCE BLOWS/FT	DESCRIPTION	REMARKS	WELL CONST.	GRAPHIC LITHO LOG
127	.6			VC SAND AND GRAVEL (2mm-10mm) BRN, w/ TRACE SILT AND CLAY (<15%) POORLY SORTED, WELL ROUNDED GRAINS, V. LOOSE, DAMP.	HNu = 0		
130				SAA	HNu = 0		
132	.3						
135							
137	1.2			SAA (0.7') GRAVEL (2mm-2cm) w/ <25% FINE MATRIX - F.M.C SAND AND SILT; MOIST(0.5)	HNu = 0		
140							
142	.6			F SAND, SILT AND CLAY w/ GRAVEL (<20mm) MC SAND, YELLOW-BRN(50%) SATURATED, V LOOSE.	HNu = 1ppm SAMPLE COLLECTED (SB140142)		
145							
147	.3			GRAVEL (<1cm) w/ TRACE SILT AND CLAY - WELL ROUNDED, MOD WELL SORTED, V. LOOSE, WET - SAT'D?	HNu = 0 COMPOSITE SAMPLE		
150							
152	.1			GRAVEL w/ TRACE CLAY AND SILT (<10%), GREY, DRY.	HNu = 0 COMPOSITE SAMPLE		



FRED C. HART ASSOCIATES, INC.

BORING NO. MW-5R

LOG OF TEST BORING

155

DEPTH (FT)	SAMPLE NO. AND TYPE	RECOVERY (FT)	PENETRATION RESISTANCE BLOW/FT	DESCRIPTION	REMARKS	WELL CONST.	GRAPHIC LITHO LOG
157	1.4			C SAND, GREY BRN, W/TRACE (<15%) GRAVEL AND CLAY. FIRM, DAMP TO MOIST, POORLY SORTED, MOD. WELL ROUNDED.	HNu = 0 COMPOSITE SAMPLE		
162	1.2			C SAND AND GRAVEL (30%) w/SOME CLAY (20%) BRN AND GREY. DAMP TO MOIST. ROUNDED GRAINS, POORLY SORTED FIRM	HNu = 0		
167	.8			C SAND AND GRAVEL (<10%) w/ TR FIM SAND, SILT AND CLAY (<15%) MOIST, POORLY SORTED, VERY LOOSE, WELL ROUNDED, CLEAN.	HNu = 0		
172	2			C-VK SAND AND GRAVEL (<10%) W/TRACE SILT AND CLAY (<10%) FIRM, POORLY SORTED, MOD WELL ROUNDED, MOIST, SL. ODOR	HNu = 3ppm		
177	.7			SAA	HNu = 0		
182	.2			SAA EXCEPT w/ ↑ SILT AND CLAY CONTENT, DRY.	HNu = N/A		



BORING NO. MW-5R

LOG OF TEST BORING

185

DEPTH (FT)	SAMPLE NO. AND TYPE	RECOVERY (FT)	PENETRATION RESISTANCE BLOW/FT	DESCRIPTION	REMARKS	WELL CONST.	GRAPHIC LITHO LOG
187	2			-VC SAND AND GRAVEL (5mm-2cm), MOIST, w/ <5% FINES (1.2'). -C SAND w/<10% GRAVEL; DRY-DAMP w/FINE SAND AND SILT, POORLY SORTED; SUBROUNDED (0.8')	H _{Nu} = 0		
190							
192	5			VC-C SAND AND GRAVEL w/<10% F SAND AND SILT, MOIST-SAT'D?, LOOSE, POORLY SORTED	H _{Nu} = 0 COMPOSITE SAMPLE		
195							
197	5			GRAVEL (2mm-1cm) w/SOME (<20%) VC-F SAND, SILT AND CLAY, BRN, V LOOSE, POORLY SORTED, SAT'D?-MOIST ALSO LS RX FRAGMENTS	H _{Nu} = 0 COMPOSITE SAMPLE		
200							
202	6			VC SAND AND GRAVEL (2mm-1cm) w/<20% F.M SAND, SILT AND CLAY, LOOSE, POORLY SORTED, MOIST-SAT'D.	H _{Nu} = 1ppm COMPOSITE SAMPLE		
205							
207	5			C-VC SAND w/ 25% F SAND, SILT AND CLAY, BRN, LOOSE, POORLY SORTED, SAT'D.	H _{Nu} = 0 VOA COLLECTED (SB 205-207)		
210							
212	7			M-C SAND, BRN-WHITE (QUARTZ) w/ TRACE GRAVEL AND FINE SAND + SILT (<15%). LOOSE TO FIRM, MOD. WELL SORTED, SUBROUNDED, SAT'D.	H _{Nu} = 0		



FRED C. HART ASSOCIATES, INC.

BORING NO. MW-5R

LOG OF TEST BORING

215

DEPTH (FT)	SAMPLE NO. AND TYPE	RECOVERY (FT)	PENETRATION RESISTANCE BLOW/FT	DESCRIPTION	REMARKS	WELL CONST.	GRAPHIC LITHO LOG
217	1.2			- SAA (0.2') - GREY, BLACK + LT GREY CLAY W/ SOME GRAVEL V. FIRM, DENSE, DRY (0.4'). - FMC SAND + GRAVEL, V LOOSE, W/ SILT + CLAY, LT-MED GREY BRN, SATURATED (0.2')	H _{Nu} = 0		
220				- F SAND SILT W/ GRAVEL (5MM-2CM) AND CLAY, LT GREY - MED BRN GREY, SL. HARD, FIRM TO LOOSE, MOIST - SAT'D. (0.4').	H _{Nu} = 1ppm COMPOSITE SAMPLE		
222	.5			M.F SAND + SILT W/ GRAVEL + CLAY (<10%); BRN - LT. BRN, DRY TO DAMP. LOOSE TO FIRM. GRAVEL (~5MM-2CM)	H _{Nu} = 0 COMPOSITE SAMPLE		
227	1			DK GREY CLAY W/ <10% GRAVEL, DRY, V FIRM, HARD. AND FM SAND AND SILT + W/DEPTH.	H _{Nu} = N/A COMPOSITE SAMPLE (SB 215-227)		
232	1			SAA (0.1') BLACK CLAY?, EXHIBITING FISSILE STRUCTURE, DRY, W/ TRACE PEBBLES, GREY; POSSIBLY WOOD FRAGMENTS, HIGHLY WEATHERED SHALE?, AND GLACIAL DEPOSITS W/ ORGANIC MATTER, V. HARD, DRY (0.9')	H _{Nu} = N/A		
237	.8			- ORANGE-BRN C SAND W/ TRACE GRAVEL + 25% F SAND SILT + CLAY, LOOSE, SAT'D. (0.4') - ORANGE BRN CLAY, DAMP, HARD, V FIRM (0.2') - ORANGE BRN C SANDY CLAY W/ TRACE GRAVEL, LOOSE TO FIRM, SLIGHTLY HARD, SAT'D.	H _{Nu} = 0 VOA SAMPLE SB235-237		
242	1.2			BRN-ORANGE/YELLOW FINE SAND AND SILT W/ TRACE C SAND, GRAVEL AND CLAY; FIRM, SL. HARD, SAT'D.	H _{Nu} = N/A COMPOSITE SAMPLE		



BORING NO. MW-5R

LOG OF TEST BORING

245

DEPTH (FT) SAMPLE NO. AND TYPE RECOVERY (FT) PENETRATION RESIST- ANCE BLOWN/FT				DESCRIPTION	REMARKS	WELL CONST.	GRAPHIC LITHO LOG
247	9			BRN C-VC SAND w/ TRACE (<15%) F SAND, SILT + CLAY, FIRM, SL HARD, SAT'D.	H _{Nu} = 0 COMPOSITE SAMPLE		
252	2			BRN VC SAND + GRAVEL (5mm-1cm) w/ 20% F SAND, SILT + CLAY; FIRM, HARD, SAT'D.	H _{Nu} = 0 COMPOSITE SAMPLE		
256	1.5			C SAND w/ <15% F SAND, SILT + CLAY, FIRM, SATURATED (0.8') GRAVEL, LOOSE (5mm-1cm), <5% FINES (0.7')	H _{Nu} = 0 SAMPLE COLLECTED		
262				GREY CLAY w/ <5% GRAVEL, TILL, V. HARD DENSE, DRY.	COMPOSITE SAMPLE		
267	1.6			BLUE-GREY CLAY w/ VC SAND (<5%) AND GRANULAR GRAVEL, HARD, V FIRM, DRY DENSE.	H _{Nu} = N/A COMPOSITE SAMPLE		
272	1			SAA	H _{Nu} = N/A		



FRED C. HART ASSOCIATES, INC.

BORING NO. MW-5R

LOG OF TEST BORING

DEPTH (FT)	SAMPLE NO. AND TYPE	RECOVERY (FT)	PENETRATION RESISTANCE BLOW/FT	DESCRIPTION	REMARKS	WELL CONST.	GRAPHIC LITHO LOG
275							
277	1			SAA (0.3') BRN-ORANGE CLAY w/ VC SAND + GRAVEL (<5%), VV HARD, V DENSE, DRY (0.7').	HN _u = N/A		
280							
282	1.5			BRN-ORANGE M-C SAND, FIRM TO LOOSE, SAT'D.	HN _u = N/A VQA. SAMPLED (SB 280-282)		
				T.D. = 282'			



FRED C. HART ASSOCIATES, INC.

TEST BORING LOG

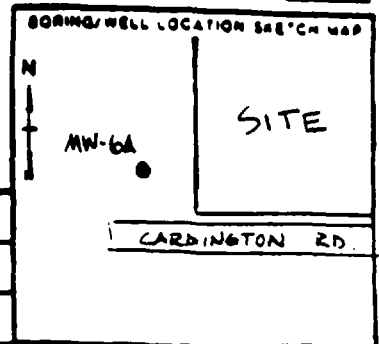

BORING NO. MW-6A

PROJECT NO. NAME 0045-00-00002-02 LOCATION DAYTON, OH

DRILLING CONTRACTOR, DRILLER MID EASTERN GEOTECH / DENVER

HART GEOLOGIST OFFICE DONALD C. SHIELDS - TERESA ROYER / PITTSBURGH

DRILLING EQUIPMENT, METHOD CME 55 / HSA SIZE, TYPE OF BIT 2" SS CONTINUOUS SAMPLING METHOD START, FINISH DATE 7-12 - 7-19-89

WELL INSTALLED? YES NO CASING MAT./DIA. SCREEN: TYPE MAT. STAINLESS LENGTH DIA. SLOT SIZE

ELEVATION OF: GROUND SURFACE TOP OF WELL CASING TOP & BOTTOM SCREEN GW SURFACE DATE (FT. ABOVE M.S.L.)

REMARKS:

LOG OF TEST BORING				WELL CONST.	GRAPHIC LITHO LOG
DEPTH (FT)	SAMPLE NO. AND TYPE	RECOVERY (FT)	PENETRATION RESISTANCE BLOWS/FT		
1				LT BRN FINE SAND LOOSE TR GRAVEL DRY SO POORLY SORTED	
1.5				LT BRN FMC SAND DAMP, SLIGHTLY HARD, 50% CLAY SO POORLY SORTED SG/GRANULAR	
5				LT BRN FMC SAND DAMP 4" FMC SAND w/ 15% CLAY, sh, ss, ps, poorly sorted.	15 ppm H ₂ S on CGI END DRILLING 7-12-89 BEGIN DRILLING 7-13-89
				F-M-C SAND, BRN, Sg, 10, 50, w/SOME PEBBLE SIZE GRAVEL, NO CLAY, POORLY SORTED DAMP	
				F-M-C BRN SAND w/MANY PEBBLES ≈ 4mm size Sg, 10, 50, NO CLAY, DAMP, POORLY SORTED	
10				MF SAND BRN w/SOME CLAY AGGREGATE SAND IS 10, 50, POORLY SORTED, DAMP, Sg CLAY IS 25% CLAY w/FN SAND, REDDISH-BROWN	H ₂ Nu READING = 0.2 ppm
				MFC SAND, BRN, w/PEBBLES, POORLY SORTED, 10, 50, DAMP, Sg	H ₂ Nu = 0.2-0.4 ppm
15				MF ORANGE-BRN SAND w/SOME SILT, Sg, 50, 10, POORLY SORTED.	H ₂ Nu = 0.2 ppm OVA = 0-15 ppm TOP OF AUGERS
				MC SAND w/GRAVEL, GRAVEL ≈ 20% Sg, 10, Sg, NO COATS ON GRAVEL	
				LT BRN, MC SAND AND GRAVEL 10mm - 2cm Sg, 6, Sg, POORLY SORTED, NO COATS ON CLASTS	

Proportions Used: Trace = 0-10%, Little = 10-20%, Some = 20-35%, And = 35-60%
 Sampling Abbreviations: SS = Split Spoon, ST = Shelby Tube, CSC = Continuous Soil Core



FRED C. HART ASSOCIATES, INC.

BORING NO. MW-6A

LOG OF TEST BORING

DEPTH (FT)	SAMPLE NO. AND TYPE	RECOVERY (FT)	PENETRATION RESISTANCE BLOW/FT	DESCRIPTION	REMARKS	WELL CONST.	GRAPHIC LOG
20		1		LT BRN TO TAN M-C SAND W/15% GRAVEL 4mm 1ca So, Sg, 10, POORLY SORTED, LESS FINES, NO COATS SLIGHTLY DAMP			
	SUBLOG-1 22-24'	1		5" C SAND + GRAVEL - BRN, SO, Sg, 10, SATURATED 7" BRN CLAY W/10% C SAND, FIRM, S, P, STRUCTURE + GRAVEL UNIDENTIFIABLE	SAMPLE (SATURATED) COLLECTED PH = 8.4		
		66		BRN F SAND W/ SILT, MOD WELL SORTED, 20% GRAVEL 4mm - 3cm, LOOSE + SOFT SO			
		6		TAN FINE SAND W/ SILT + SOME GRAVEL 3mm-1cm (~5%) MOD WELL SORTED, SO, 10, Sg SLIGHTLY DAMP			
		1		TAN F SAND W/ GRAVEL 25% (4mm - 2cm 10, SO, Sg - V SLIGHTLY DAMP, MOD WELL SORTED	SPOON DRIVEN ONLY 1 FT. H ₂ O = 0.1ppm		
30				TAN TO WHITE F SAND W/ GRAVEL (4-5% AT TOP TO 10% AT BOTTOM) So, Sg, 10, WELL SORTED WELL ROUNDED, NO COATS ON GRAVEL, DRY	SPOON DRIVEN ONLY 1 FT.		
		1		SAND, FN-COARSE GR, LT BRN, DAMP, POORLY SORTED, GRAVEL INTERMIXED, NO ODOR			
		1		SAND, FN-COARSE GR, LT BR, DAMP, POORLY SORTED LARGE COBBLE (~1"), DRY TOWARD BOTTOM NO ODOR.	SPOON DRIVEN 1'3" END DRILLING 7-13-89		
		1.5		SAND, FN-MED GR, LT BR, MOIST, HIGH CLAY CONTENT, NO ODOR.	BEGIN DRILLING 7-14-89		
		2		SAND FN-GR, LT BR, HIGH CLAY CONTENT, DAMP, PLASTIC, NO ODOR.			
40		15		7" SAND FN-GR, LT BR, HIGH CLAY CONTENT, DAMP PLASTIC NO ODOR. 1' LT BRN F SAND + SOME SILT 10, SO, Sg, damp MOD WELL SORTED			
		1		LT BRN F SAND + SOME SILT, 10, 30, Sg, DAMP MOD. WELL SORTED			
		1		LT BRN F SAND + SOME SILT, 10, SO, Sg, DAMP, MOD WELL SORTED			
		2		BRN VERY FINE SAND + SILT FS, MOIST NO GRAVEL			
		1.5		V F + F SAND, BRN, NO GRAVEL, SO, 10, Sg DAMP	END DRILLING 7-14-89		
50							



FRED C. HART ASSOCIATES, INC.

BORING NO. MW-6A

LOG OF TEST BORING

50

60

DEPTH (FT)	SAMPLE NO. AND TYPE	RECOVERY (FT)	PENETRATION RESISTANCE BLOWN/FT	DESCRIPTION	REMARKS	WELL CONST.	GRAPHIC LITHO LOG
		2		SAND, MED GR, LT BR, WELL SORTED, COMPACTED NO ODOR, MOIST.	BLEN DRILLING 7-11-87		
	SBC10A / 2400A / 52.54	1		SAND, FN-MED GR, SOME CLAY, LT BRN, GRAY AT BOTTOM, MOIST AT TOP <u>WET</u> AT BOTTOM	▽		
	SBC10A / 2400A / 54.54	1.5		SAND FN GR, SOME CLAY LT BR AT TOP, LT GREY AT BOTTOM WET, NO ODOR			
	SBC10A / 2400A / 56.58	1.5		SAND, FN-MED GR, LT BROWNISH GR, WET, NO ODOR			
		2		18" FNE-MED GR LT BRNISH SAND, WET, NO ODOR 6" GREY SILTY CLAY (DRY)			
				T.D = 60'			
				10 - LOOSE S0 - SOFT S - STICKY SS - SLIGHTLY STICKY } CONSISTENCY P - PLASTIC PS - SLIGHTLY PLASTIC } SH - SLIGHTLY HARD = MEDIUM DENSE H - HARD SG - SINGLE GRAIN			



FRED C. HART ASSOCIATES, INC.

TEST BORING LOG

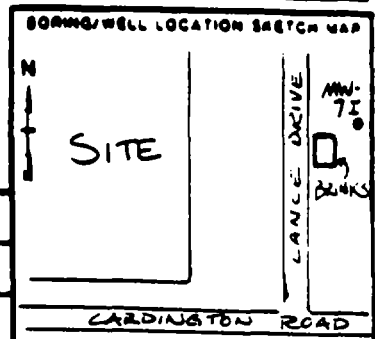

BORING NO. MW-7I		PROJECT NO. NAME 00615-00-00002 / CRC		LOCATION DAYTON, OH
DRILLING CONTRACTOR, DRILLER MID EASTERN GEOTECH / WADE SIGLER				
HART GEOLOGIST, OFFICE DC SHIELDS / PGH				
DRILLING EQUIPMENT, METHOD CABLE TOOL		SIZE/TYPE OF BIT 6" Ø	SAMPLING METHOD CONT SS	START, FINISH DATE 9/21/89-10/3/89
WELL INSTALLED? YES <input checked="" type="checkbox"/> NO <input type="checkbox"/>	CASING MAT./DIA. STEEL / 6" Ø	SCREEN TYPE	MAT. STAINLESS LENGTH	DIA. 2" SLOT SIZE
ELEVATION OF: (FT. ABOVE M.S.L.)	GROUND SURFACE	TOP OF WELL CASING	TOP & BOTTOM SCREEN	GW SURFACE DATE
REMARKS:				

LOG OF TEST BORING				WELL CONST.	GRAPHIC LITHO LOG	
DEPTH (FT)	SAMPLE NO. AND TYPE	RECOVERY (FT)	PENETRATION RESISTANCE BLOWS/FT			DESCRIPTION
2	1.5			SILT, LT BRN AND GRAVEL, GREY, DRY	HNu=0	
4	1			SILTY CLAY, LT BR + GRAVEL, POORLY SORTED DRY.	HNu=0	
5	1.5			CLAY, LT BR + GRAVEL, POORLY SORTED, DRY.	HNu=0	
6	5			GRAVEL, WELL-ROUNDED, W/SOME CLAY, HARD DRY.	HNu=0	
8	1			CLAY, LT BR + GRAVEL (WELL-ROUNDED, LT GREY) POORLY SORTED, DRY, HARD.	HNu=0	
10	5			AS ABOVE	HNu=0	
12	1			GRAVEL, ANGULAR, LT GREY, W/SILT, HARD, DRY	HNu=0	
14	1			AS ABOVE	HNu=0	
16	1			AS ABOVE	HNu=0	
18	1			AS ABOVE	HNu=0	
20	1			AS ABOVE	HNu=0	

Proportions Used: Trace = 0-10%, Little = 10-20%, Some = 20-35%, And = 35-50%
 Sampling Abbreviations: SS = Split Spoon, ST = Shelby Tube, CSC = Continuous Soil Core



FRED C. HART ASSOCIATES, INC.

BORING NO. MW-7I

LOG OF TEST BORING

DEPTH (FT)
SAMPLE NO. AND TYPE
RECOVERY (FT)
PENETRATION RESISTANCE
BLOWS/FT

WELL CONST.
GRAPHIC LITHO LOG

DEPTH (FT)	RECOVERY (FT)	DESCRIPTION	REMARKS
22	.5	GRAVEL, SUBROUNDED, LT GREY + SILTY. CLAY, LT BR, HARD, DRY.	HNu=0
24	1.5	SAA	HNu=0
26	1	SAA	HNu=0
28	1.5	SILTY CLAY (LT BR) + GRAVEL; ROCK FRAGMENTS @ BOTTOM, DRY.	HNu=0
30	1.5	SILT + F SAND (LT BR) + GRAVEL, LT GREY, ROUNDED, DRY.	HNu=0
32	0	No RECOVERY	HNu=NR
34	1.5	M SAND, LT BR, DRY W/ SOME GRAVEL.	HNu=0
36	1	SAA	HNu=0
38	1	SAA, DAMP.	HNu=0
40	1.5	M.C SAND, LT BR, W/GRAVEL, ROUNDED DAMP.	HNu=0
42	1.5	M.C SAND, LT BR., DAMP.	HNu=0
44	2	SAA	HNu=0
46	1.5	SAA	HNu=0
48	1.5	GRAVEL, ROUNDED + ROCK FRAGMENTS, w/ M SAND, POORLY SORTED, DRY, HARD.	HNu=0
50	1.5	SAA	HNu=0

20



FRED C. HART ASSOCIATES, INC.

BORING NO. MW-7I

LOG OF TEST BORING

50

DEPTH (FT)	SAMPLE NO. AND TYPE	RECOVERY (FT)	PENETRATION RESISTANCE BLOW/FT	DESCRIPTION	REMARKS	WELL CONST.	GRAPHIC LITHO LOG
52	1.5			SAA	HNu=0		
54	1.5			SAA	HNu=0		
56	1.5			SAA	HNu=0		
58	1.5			MC SAND, LT BRN W/ GRAVEL, ROUNDED + ANGULAR, POORLY SORTED, DRY, HARD.	HNu=0		
60	1.5			SAA	HNu=0		
62	1.5			SAA	HNu=0		
64	1.5			SAA	HNu=0		
66	1.2			MC SAND W/ GRAVEL AND SOME CLAY, DAMP, MOD FIRM.	HNu=0		
68	1.5			SILT, F SAND + GRAVEL, LT BR, POORLY SORTED, DRY, HARD	HNu=0		
70	2			SAA	HNu=0		
72	1.5			MC SAND, LT BR, DRY, W/ GRAVEL, ROUNDED SOME CLAY.	HNu=0		
74	1			GRAVEL, ROUNDED + ROCK FRAGMENTS, W/ MC SAND, LT BR, DRY, HARD.	HNu=0.5		
76	.5			SAA W/ SH FRAGMENTS	HNu=2PPM SPON REFUSAL @ 1'		
78	1.5			GRAVEL + ROCK FRAGS., LARGE (2"), LT GREY, SOME SILT + CLAY, DRY.	HNu=0		
80	2'			SAA	HNu=0		



LOG OF TEST BORING

82

DEPTH (FT)	SAMPLE NO. AND TYPE	RECOVERY (FT)	PENETRATION RESISTANCE BLOW/FT	DESCRIPTION	REMARKS	WELL CONST.	GRAPHIC LITHO LOG
84		1.5		SAA	HNu=0		
86		1		GRAVEL, ROUNDED; ROCK FRAGS; F SAND AND SILT, LT BR, DRY.	HNu=0		
88		1		MC SAND, LT BR, WELL SORTED, LOOSE, DRY.	HNu=0		
90		.25		SAA	HNu=0		
92		1		ROCK FRAGS, LARGE (1-2"), ANGULAR, LT GREY, SOME MC SAND, LT BR, DRY.	HNu=0		
94		1		ROCK FRAGS, GRAVEL, SAND + CLAY, LOOSE, LT BR.	HNu=0		
96		1.5		GRAVEL + MC SAND (LT BR), TIGHT, DRY.	HNu=0		
98		1.5		GRAVEL, C SAND + SILTY CLAY, LT BR. TIGHT, DRY.	HNu=0		
100		1.5		SILTY CLAY, LT BR DRY, W/GRAVEL, POORLY SORTED, TIGHT.	HNu=0		
102		1		SAA	HNu=0		
104		1.5		GRAVEL + ROCK FRAG W/SILTY CLAY, DRY, TIGHT.	HNu=0.5		
106		1		SILT, SAND + GRAVEL, LT BR, LOOSE.	HNu=0		
108		1		SAA	HNu=0		
110		1		ROCK FRAGS, GRAVEL + SILTY CLAY LT BR, DRY, TIGHT	HNu=0		
112		1.5		SAA	HNu=0		



FRED C. HART ASSOCIATES, INC.

BORING NO. MW-7I

LOG OF TEST BORING

DEPTH (FT)
SAMPLE NO. AND TYPE
RECOVERY (FT)
PENETRATION RESIST-
ANCE BLOWN/FT

DESCRIPTION

REMARKS

WELL CONST.

GRAPHIC
LITHO LOG

DEPTH (FT)	SAMPLE NO. AND TYPE	RECOVERY (FT)	DESCRIPTION	REMARKS	WELL CONST.	GRAPHIC LITHO LOG
114	1.5		SAA	HNu=0		
116	1		SAA	HNu=0		
118	1		MC SAND, LT BR (0.5')			
119			CLAY, LT BR, HARD W/ SOME GRAVEL (0.5')	HNu=0		
120	1.5		ROCK FRAGS AND GRAVEL, TIGHT, W/ SILTY CLAY, HARD DRY.	HNu=0		
122	1		SILT, LT BR, DAMP (0.5')			
122			GRAVEL. W/SOME SILT, HARD, DRY (0.5')	HNu=0		
124	1.5		SILT, LT BR, DRY (0.5')			
124			MC SAND, BR, DRY AND GRAVEL, ROUNDED, TIGHT. (1.0')	HNu=0		
126	1.5		MC SAND, BRN + GRAVEL (<2", SUBROUNDED) TIGHT, DRY.	HNu=0		
128	1.5		SAA	HNu=0		
130	1		SAA	HNu=0		
132	1.5		GRAVEL, MC SAND + SILT, LOOSE, DRY (1.0')			
132			M SAND, WELL SORTED, DRY. (0.5')	HNu=0		
134	1		GRAVEL, ROCK FRAGS, FMC SAND, + SILT, LT BR., DRY.	HNu=0		
136	1.5		GRAVEL, ROCK FRAGS, + SILT, LT BR., DRY.	HNu=0		
138	2		MC SAND, LT BR, DRY, TIGHT, SOME GRAVEL.	HNu=0		
140	1		MC SAND + GRAVEL, ROUNDED, LT BR, DAMP.	HNu=0		
142	1		M SAND, LT BR, DRY, W/ ROCK FRAGS.	HNu=0		



FRED C. HART ASSOCIATES, INC.

BORING NO. MW-7I

DEPTH (FT)
SAMPLE NO. AND TYPE
RECOVERY (FT)
PENETRATION RESIST-
ANCE BLOWS/FT

LOG OF TEST BORING

WELL CONST.
GRAPHIC
LITHO LOG

DESCRIPTION

REMARKS

142

144	1		M SAND, BR, LOOSE, MOIST (0.5')	H _{Nu} = 0		
146	.5		GRAVEL + SAND, LT BR, LOOSE, WET. (0.5')	SAMPLE: (7A 142-144)		
148	.5		GRAVEL, ROUNDED, LT BR, W/MC SAND, LOOSE, WET.	H _{Nu} = 0		
150	1		GRAVEL + ROCK FRAGS, W/ MC SAND, WET, SOME CLAY.	H _{Nu} = 0		
152			MC SAND, LT BR, GRAVEL + ROCK FRAGS. WET.	H _{Nu} = 0		
			GRAVEL + C SAND W/SILTY CLAY, TIGHT, MOIST @ BOTTOM.			
			T.D. = 152'			



FRED C. HART ASSOCIATES, INC.

TEST BORING LOG

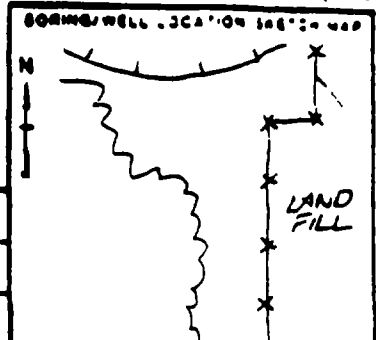

BORING NO. MW08A	
PROJECT NO., NAME CARDINGTON ROAD LANDFILL	LOCATION MORaine, CHIC
DRILLING CONTRACTOR DRILLER BOWSER-MORNER, SKEETER PATTERSON	
HART GEOLOGIST OFFICE GEORGE HUNZEKER, PITTSBURGH	
DRILLING EQUIPMENT METHOD CABLE TOOL, BUCYRUS W17	SIZE, TYPE OF BIT NOMINAL 7"
SAMPLING METHOD SPLIT SPOON	
START, FINISH DATE 07/15/90 - 07/16/90	
WELL INSTALLED? YES <input checked="" type="checkbox"/> NO <input type="checkbox"/>	CASING MAT., DIA. 2" STAINLESS
SCREEN: 5CM 40 TYPE 304	MAT. STAINLESS LENGTH 16' DIA. 2" SLOT SIZE 60/100
ELEVATION OF: (FT. ABOVE M.S.L.)	GROUND SURFACE TOP OF WELL CASING TOP & BOTTOM SCREEN GW SURFACE DATE

REMARKS:

LOG OF TEST BORING					WELL CONST.	GRAPHIC LITHO LOG
DEPTH (FT)	SAMPLE NO. AND TYPE	RECOVERY (FT)	PENETRATION RESISTANCE BLOWS/FT	DESCRIPTION		
55				NO SAMPLES COLLECTED TO 63' REFER TO MW08M LOG FOR 0-63'		
60						
65				T.D. 65'		

Proportions Used: Trace = 0-10%, Little = 10-20%, Some = 20-35%, And = 35-60%



FRED C. HART ASSOCIATES, INC.

TEST BORING LOG

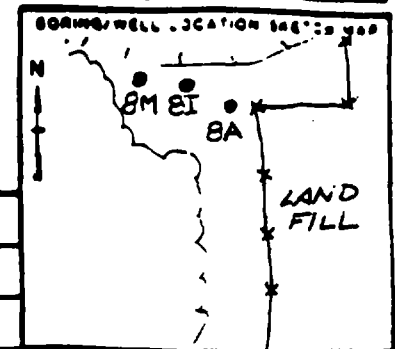

BORING NO. MW081		PROJECT NO. NAME CARDINGTON ROAD LANDELL		LOCATION MCRAINE OHIO	
DRILLING CONTRACTOR/DRILLER SOWSER-MORNER, JEFFER DATTERSON		HART GEOLOGIST OFFICE MARTHA FLEMING, PITTSBURGH		DRILLING EQUIPMENT, METHOD CABLE TOOL BUCKRUS WIF	
WELL INSTALLED? YES <input checked="" type="checkbox"/> NO <input type="checkbox"/>		CASING MAT., DIA. 2" STAINLESS		SIZE, TYPE OF BIT NOMINAL 7 AND 8"	
ELEVATION OF: (FT. ABOVE M.S.L.)		SCREEN: 304 TYPE SCH. 40 MAT. STAINLESS LENGTH 10' DIA. 2" SLOT SIZE 0.010		SAMPLING METHOD SPLIT SPOON	
REMARKS:		ELEVATION OF: (FT. ABOVE M.S.L.)		START, FINISH DATE 06/26/90 - 06/29/90	
		TOP OF WELL CASING		GW SURFACE	
		TOP & BOTTOM SCREEN		DATE	

LOG OF TEST BORING				WELL CONST.	GRAPHIC LITHO LOG	
DEPTH (FT)	SAMPLE NO. AND TYPE	RECOVERY (FT)	PENETRATION RESISTANCE BLOWS/FT			DESCRIPTION
0-66'						NOSAMPLES COLLECTED TO 66', REFER TO MW081M LOG FOR 0-66'
1.5						GRAY-BROWN SILT AND FINE SAND 41% CLAY SATURATED ; MODERATELY TIGHT TO MODERATELY LOOSE
10						GRAY CLAY 20 30% SILT, DAMPTO MOIST, MODERATELY TIGHT
135						⚡ ⚡
						T.D. 137.5'

Proportions Used: Trace = 0-10%, Little = 10-20%, Some = 20-35%, And = 35-50%
 Sampling Abbreviations: SS = Split Spoon, ST = Shelby Tube, CSC = Continuous Soil Core



FRED C. HART ASSOCIATES, INC.

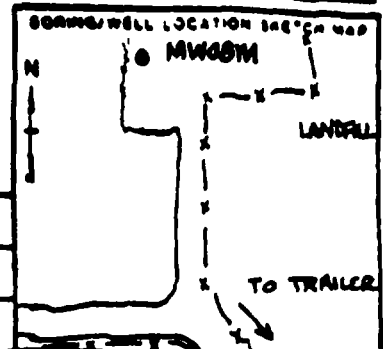

TEST BORING LOG

BORING NO. MW008M					
PROJECT NO. NAME CARDINGTON ROAD LANDFILL	LOCATION MORaine, OHIO				
DRILLING CONTRACTOR, DRILLER BOWSER - MORNER, SKEETER PATTERSON					
HART GEOLOGIST OFFICE MARTHA FLEMING, PITTSBURGH					
DRILLING EQUIPMENT, METHOD CABLE TOOL RIG	SIZE, TYPE OF BIT	SAMPLING METHOD SPLIT SPOON	START, FINISH DATE 06/21/00 - 06/26/00		
WELL INSTALLED? YES <input checked="" type="checkbox"/> NO <input type="checkbox"/>	CASING MAT./DIA. 2" STAINLESS	SCREEN: TYPE SLOTTED MAT. STAINLESS LENGTH 20' DIA. 2" SLOT SIZE			
ELEVATION OF: (FT. ABOVE M.S.L.)	GROUND SURFACE	TOP OF WELL CASING	TOP & BOTTOM SCREEN	GW SURFACE	DATE
REMARKS:					

LOG OF TEST BORING				WELL CONST.	GRAPHIC LITHO LOG
DEPTH (FT)	SAMPLE NO. AND TYPE	RECOVERY (FT)	PENETRATION RESISTANCE BLOWS/FT		
5	1	0.5		BROWN SILT, CLAYEY 10-20%, FINE SAND; DAMP AND SOFT.	HNU=0
10	2	1.0		SOOPY SILT AND FINE SAND	HNU=0
15	3	0.5		BROWN TO RED; BROWN CLAY; SOFT, MOIST, PLASTIC.	HNU=0

Proportions Used: Trace = 0-10%, Little = 10-20%, Some = 20-35%, And = 35-50%
 Sampling Abbreviations: SS = Split Spoon, ST = Shelby Tube, CSC = Continuous Soil Core



FRED C. HART ASSOCIATES, INC.

BORING NO. MW08M

LOG OF TEST BORING

DEPTH (FT)	SAMPLE NO. AND TYPE	RECOVERY (FT)	PENETRATION RESISTANCE BLOW/FT	LOG OF TEST BORING		WELL CONST.	GRAPHIC LITHO LOG
				DESCRIPTION	REMARKS		
20	4	1.0		MEDIUM - FINE SAND WITH 10-20% SILT AND SUBROUNDED PEBBLES. GRADES TO A DARK BROWN CLAYEY SILT, 30% MEDIUM SAND WITH SUBANGULAR TO SUBROUNDED PEBBLES.	H _N U = 0		
25	5	1.0		BROWN FINE SAND WITH ROUNDED TO SUBROUNDED GRAVEL; DAMP TO DRY, LOOSE	H _N U = 0		
30	6	1.0		BROWN FINE SAND WITH SMALL AMOUNT OF MEDIUM SAND.	H _N U = 0		
35	7	1.5		DRY BROWN, LOOSE, DENSE, FINE SAND WITH 10% SILT AND 10% SUBANGULAR TO SUBROUNDED GRAVEL.	H _N U = 0.2		
40	8	1.0		BROWN, DRY, LOOSE MEDIUM SAND	H _N U = 0.2		
45	9	1.5		BROWN, TIGHT, FINE SAND, DRY TO DAMP	H _N U = 0.1		
50							



FRED C. HART ASSOCIATES, INC.

BORING NO. MW08M

LOG OF TEST BORING

WELL CONST.
GRAPHIC LITHO LOG

DEPTH (FT)
SAMPLE NO. AND TYPE
RECOVERY (FT)
PENETRATION RESISTANCE
BLOWS/FT

DESCRIPTION

REMARKS

16	1.0	SILT WITH 20-30% FINE SAND, <5% GRAVEL MODERATELY TIGHT, BROWN TO RED BROWN. GRADES TO SILT WITH 10% CLAY, <10% FINE SAND AND <5% GRAVEL.	HNU=0	
85	17	1.0	BROWN MODERATELY LOOSE, DRY TO DAMP POORLY SORTED MEDIUM-FINE SAND, <10% FINES. 30% SUBROUNDED TO SUBANGULAR GRAVEL.	HNU=0
90	18	1.0	BROWN POORLY SORTED MEDIUM-FINE SAND. WITH 30% SUBROUNDED TO SUBANGULAR GRAVEL, <10% FINES	HNU=0.1
95	19	1.0	BROWN FINE SAND, <10% FINES, 20-30% SILT, RED-BROWN-MOTTLED, FIRM.	HNU=0.1
100	20	1.5	BROWN, MODERATELY LOOSE, DRY TO DAMP POORLY SORTED MEDIUM-FINE SAND. <10% FINES, 30% SUBROUNDED TO SUBANGULAR GRAVEL.	HNU=1.1
105	21	1.0	BROWN MEDIUM TO FINE SAND WITH <10% FINES, 10% SUBANGULAR TO SUBROUNDED GRAVEL; MODERATELY LOOSE, POORLY SORTED, DRY TO DAMP.	HNU=0.6
110				



FRED C. HART ASSOCIATES, INC.

BORING NO.
MW08M

		LOG OF TEST BORING		WELL CONST.	GRAPHIC LITHO LOG
DEPTH (FT)	SAMPLE NO. AND TYPE	RECOVERY (FT)	DESCRIPTION	REMARKS	
115	22	1.5	BROWN MEDIUM TO FINE SAND, <10% FINES, 30% GRAVEL, 15% SUBANGULAR TO ROUNDED GRAVEL, MODERATELY LOOSE.	HNU = 0.4	
120	23	1.0	BROWN MEDIUM SAND; <5% FINES, 30-40% GRAVEL; SUBANGULAR TO ROUNDED. DRY, POORLY SORTED.	HNU = 0.2	
125	24	1.0	BROWN TO RED BROWN, DRY TO DAMP, TIGHT, MEDIUM SAND AND GRAVEL; POORLY SORTED.	HNU = 0.3	
130	25	1.0	BROWN TO RED-BROWN, MODERATELY TIGHT, DAMP TO MOIST, MEDIUM-FINE SAND AND GRAVEL - POORLY SORTED.	HNU = 0.4	
135	26	1.5	BROWN TO RED-BROWN POORLY SORTED GRAVEL AND MEDIUM SAND.	HNU = 0	
140	27	1.0	BROWN, MODERATELY LOOSE, MEDIUM SAND AND POORLY SORTED GRAVEL. 20-30% FINES	HNU = 0	



FRED C. HART ASSOCIATES, INC.

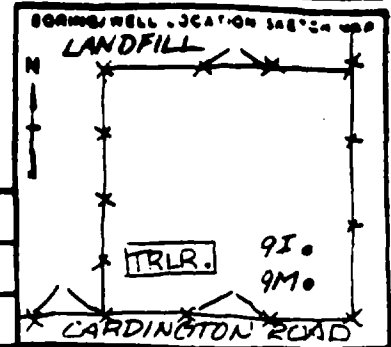

TEST BORING LOG

BORING NO. MW091			
PROJECT NO. NAME CARDINGTON ROAD LANDFILL	LOCATION MORRINE, OHIO		
DRILLING CONTRACTOR, DRILLER DUNSER-MORNER, JEFF RIDDLE			
HART GEOLOGIST OFFICE GEORGE MUNZEKER, PITTSBURGH			
DRILLING EQUIPMENT METHOD CABLE TOOL BUCYRUS W27	SIZE TYPE OF BIT NOMINAL	SAMPLING METHOD SPLIT SPOON	START FINISH DATE 06/26/90 - 06/29/90
WELL INSTALLED? YES <input checked="" type="checkbox"/> NO <input type="checkbox"/>	CASING MAT., DIA. 2" STAINLESS	SCREEN: 507.40 TYPE 304	MAT. STAINLESS LENGTH 10' DIA. 2" SLOT SIZE 0.010
ELEVATION OF: (FT. ABOVE M.S.L.)	GROUND SURFACE	TOP OF WELL CASING	TOP & BOTTOM SCREEN GW SURFACE DATE
REMARKS:			

LOG OF TEST BORING					WELL CONST.	GRAPHIC LITHO LOG
DEPTH (FT)	SAMPLE NO. AND TYPE	RECOVERY (FT)	PENETRATION RESISTANCE BLOWS/FT	DESCRIPTION		
0						
5						
10						
15						
18						
145						

NO SAMPLES COLLECTED; REFER TO MW09M LOG FOR 0-145'

T.D. 145'

Proportions Used: Trace = 0-10%, Little = 10-20%, Some = 20-35%, And = 35-50%
 Sampling Abbreviations: SS = Split Spoon, ST = Shelby Tube, CSC = Continuous Soil Core



FRED C. HART ASSOCIATES, INC.

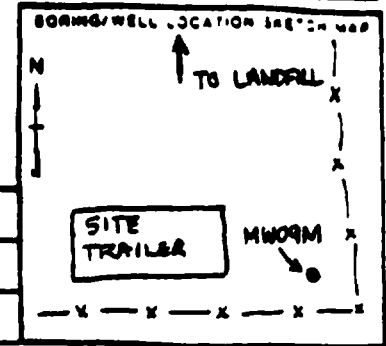

TEST BORING LOG

BORING NO. MW09M			
PROJECT NO. NAME CARDINGTON ROAD LANDFILL	LOCATION MORaine, OHIO		
DRILLING CONTRACTOR, DRILLER BOWSER MORNER, JEFF RIDDLE			
HART GEOLOGIST OFFICE GEORGE HUNZEKER, PITTSBURGH			
DRILLING EQUIPMENT, METHOD CABLE TOOL RIG	SIZE/TYPE OF BIT	SAMPLING METHOD SPLIT SPOON	START, FINISH DATE 06/21/90 - 06/26/90
WELL INSTALLED? YES <input checked="" type="checkbox"/> NO <input type="checkbox"/>	CASING MAT./DIA. 2" STAINLESS	SCREEN: TYPE SLOTTED MAT. STAINLESS LENGTH 20' DIA. 2" SLOT SIZE	
ELEVATION OF: (FT. ABOVE M.S.L.)	GROUND SURFACE	TOP OF WELL CASING	TOP & BOTTOM SCREEN
REMARKS:	GW SURFACE	DATE	

LOG OF TEST BORING				WELL CONST.	GRAPHIC LITHO LOG	
DEPTH (FT)	SAMPLE NO. AND TYPE	RECOVERY (FT)	PENETRATION RESISTANCE BLOWS/FT			DESCRIPTION
5	1	1.5			BROWN-TAN COARSE SAND WITH ROUNDED GRAVEL. POORLY SORTED, DRY, LOOSELY PACKED. GRADES TO A FINER SAND WITHOUT GRAVEL AT APPROXIMATELY 7 FEET.	HNU=0
10	2	1.5			BROWN-TAN SILTY SAND, COHESIVE, DRY WITH MINOR AMOUNTS OF IRON STAINING	HNU=0
15	3	1.75			TAN-LIGHT BROWN DRY, POORLY SORTED MEDIUM SAND WITH A LARGE AMOUNT OF LARGE ROUNDED PEBBLES AND GRAVEL.	HNU=0
20						

Proportions Used: Trace = 0-10%, Little = 10-20%, Some = 20-35%, And = 35-60%

Sampling Methods: SS - Split Spoon, ST - Shelby Tube, CSC - Continuous Soil Core



BORING NO. NW09M

DEPTH (FT)		SAMPLE NO. AND TYPE	RECOVERY (PT)	PENETRATION RESISTANCE BLOW/FT	LOG OF TEST BORING	WELL CONST.	GRAPHIC LITHO LOG
					DESCRIPTION	REMARKS	
10	1.5				BROWN MEDIUM-COARSE SAND WITH POORLY SORTED, SEMI-ROUNDED GRAVEL AND ROCK FRAGMENTS.	HNU=0	
55	11	1.25			TAN-BROWN COARSE SAND AND POORLY SORTED GRAVEL WITH LARGE AMOUNT OF IRREGULAR ANGULAR ROCK FRAGMENTS. DRY, VERY DENSE, HARD	HNU=0	
60	12	1.5			TAN-BROWN COARSE SAND AND GRAVEL WITH IRREGULAR ROCK FRAGMENTS, POORLY SORTED, SLIGHTLY MOIST (MINOR AMOUNT OF VERY PURE COARSE QUARTZ SAND).	HNU=0	
65	13	1.0			TAN-BROWN COARSE SAND AND POORLY SORTED GRAVEL WITH ANGULAR ROCK FRAGMENTS. SLIGHTLY MOIST.	HNU=0	
70	14	1.0			TAN-BROWN COARSE SAND AND POORLY SORTED GRAVEL WITH ANGULAR ROCK FRAGMENTS, MOIST.	HNU=0	
75	15	1.25			TAN-BROWN SILTY CLAY WITH SAND AND GRAVEL. COHESIVE AND DRY.	HNU=0	
80							



FRED C. HART ASSOCIATES, INC.

BORING NO.
MW09M

DEPTH (FT)		SAMPLE NO. AND TYPE		RECOVERY (FT)		PENETRATION RESISTANCE BLOWN/FT		LOG OF TEST BORING		WELL CONST.	GRAPHIC LITHO LOG
		DESCRIPTION		REMARKS							
145	28	1.5			TAN-BROWN COARSE SAND AND POORLY SORTED GRAVEL. NON-COHESIVE AND MOIST.	HNU=0					
150	29	1.25			BROWN-TAN COARSE SAND AND SEMI-ROUNDED, POORLY SORTED GRAVEL. NON COHESIVE, WET.	HNU=0					
155	30	1.25			BROWN MEDIUM-COARSE SAND WITH POORLY SORTED, SEMI-ROUNDED GRAVEL. NON-COHESIVE, WET.	HNU=0					
160	31	0.5			POORLY SORTED GRAVEL WITH BROWN MEDIUM-COARSE SAND. NON-COHESIVE AND WET.	HNU=0					
165					SAMPLE INADVERTANTLY NOT TAKEN AT THIS INTERVAL.						
170	32				GRAVEL WITH BROWN COARSE SAND, POORLY SORTED, SEMI-ROUNDED, NON-COHESIVE, WET.						

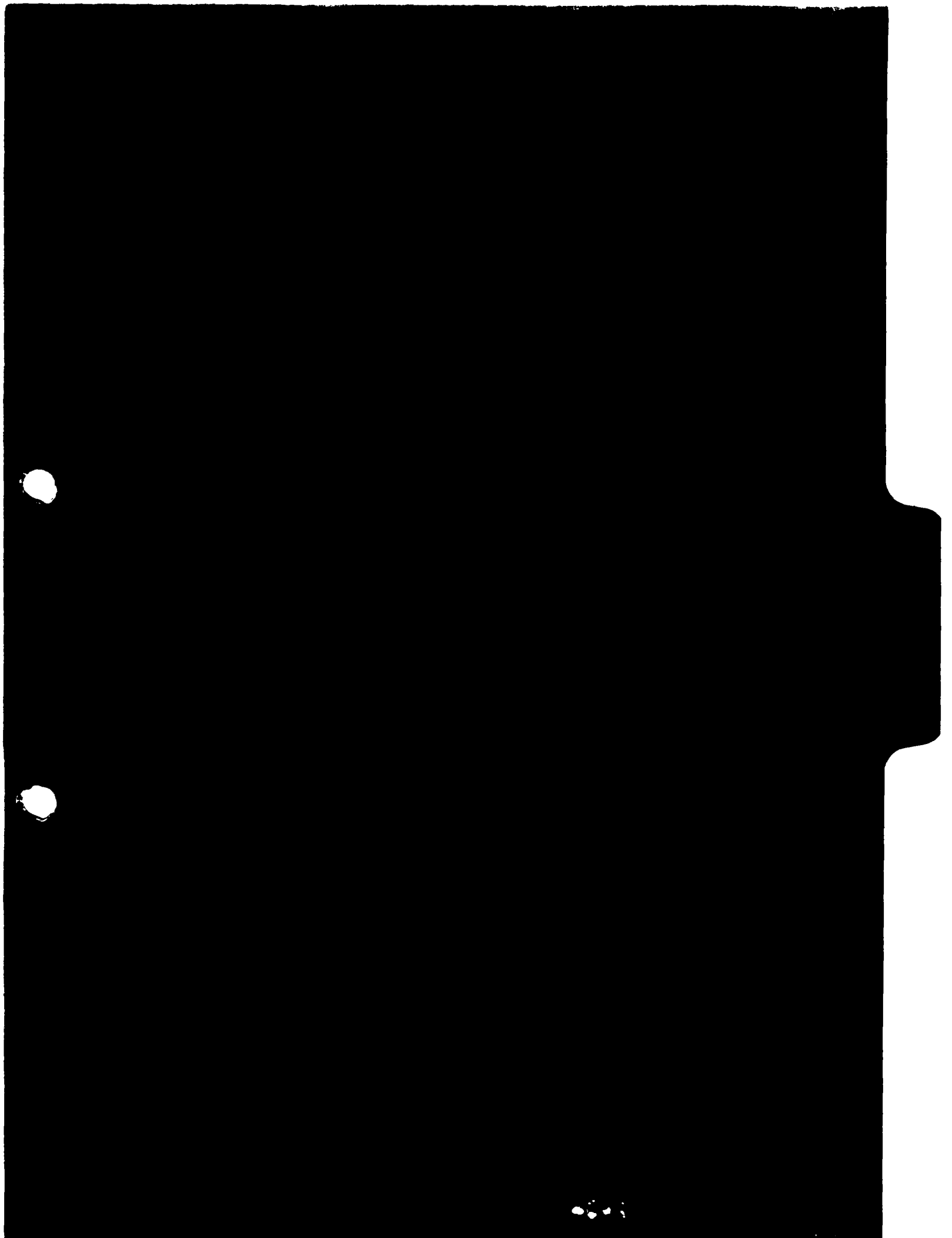

APPENDIX C

PERIMETER MONITORING WELL
CONSTRUCTION DIAGRAMS



McLAREN/HART

MONITORING WELL MW-1I

PROJECT: CARDINGTON ROAD LANDFILL SITE

LOCATION: MORaine, OHIO

DRILLING METHOD: CABLE TOOL

DATES OF COMPLETION: 9/8/89 - 9/19/89

DRILLING CONTRACTOR: MID-EASTERN GEOTECH

GEOLOGIST: SHIELDS, McCREA

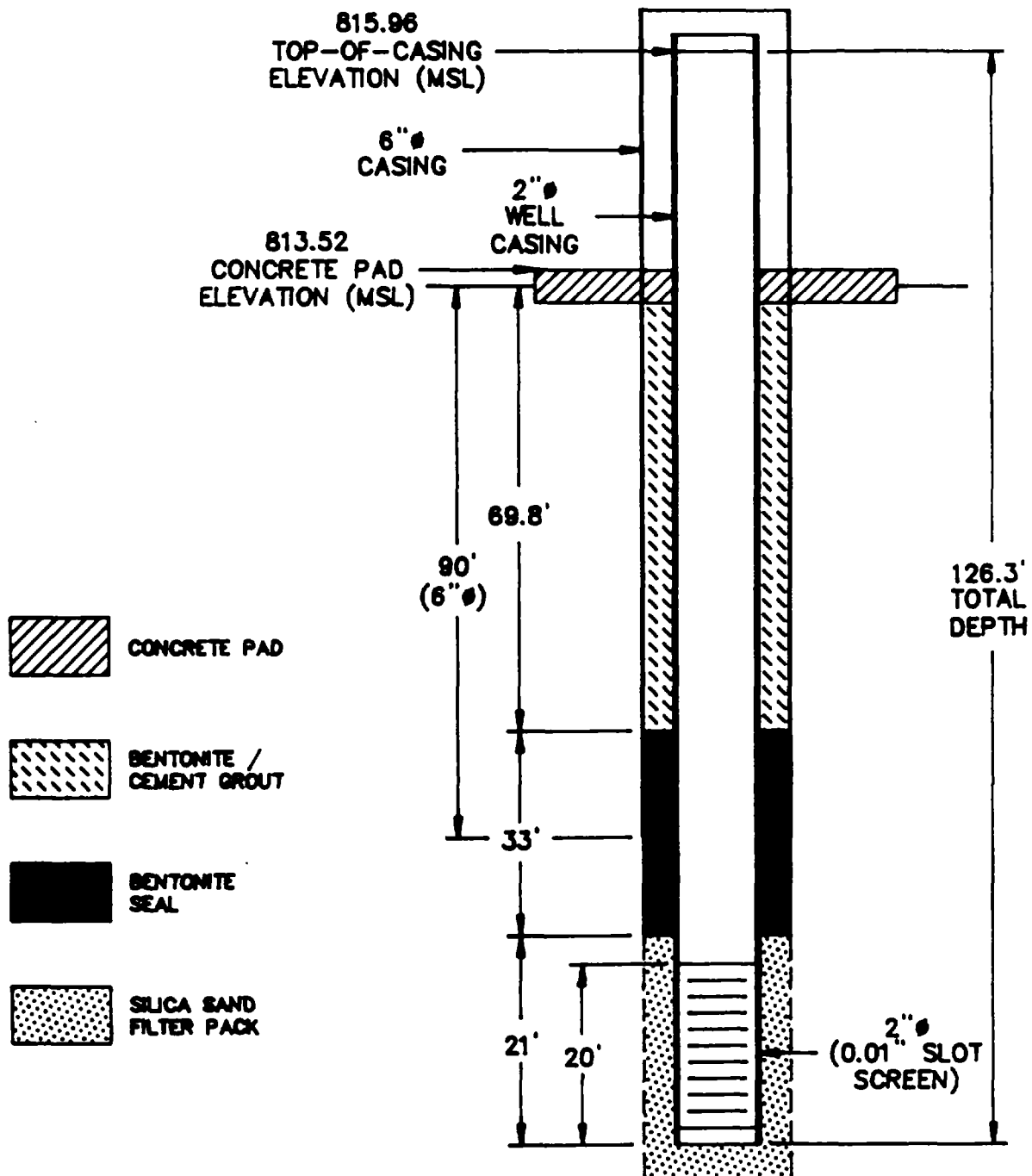

ALL DEPTHS ARE APPROXIMATE



McLAREN/HART

MONITORING WELL MW-1R

PROJECT: CARDINGTON ROAD LANDFILL SITE

LOCATION: MORaine, OHIO

DRILLING METHOD: CABLE TOOL

DATES OF COMPLETION: 10/9/89 - 11/2/89

DRILLING CONTRACTOR: MID-EASTERN GEOTECH

GEOLOGIST: SHIELDS, FLEMING, SHAWLEY, McCREA

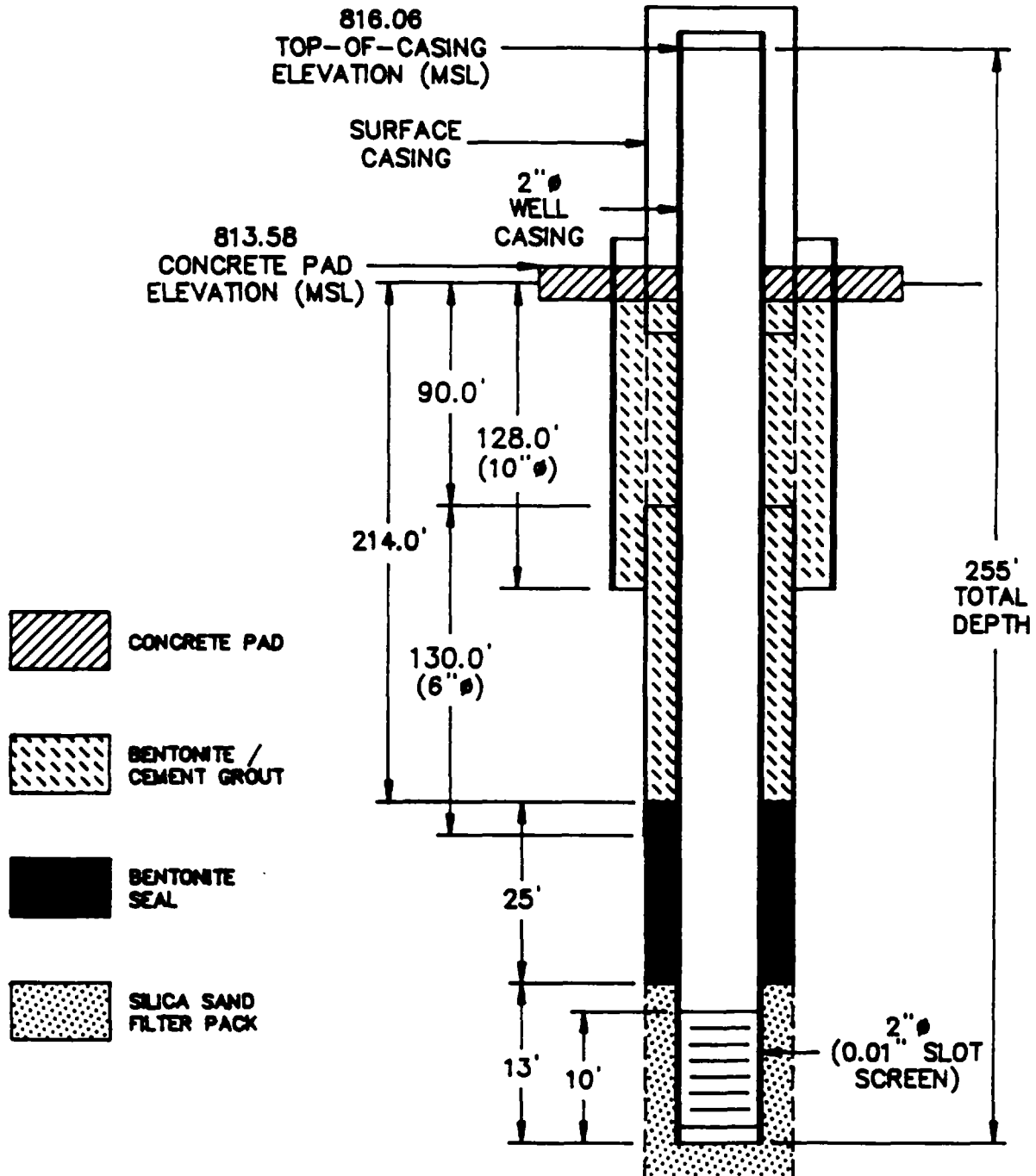

ALL DEPTHS ARE APPROXIMATE



McLAREN/HART

MONITORING WELL MW-21

PROJECT: CARDINGTON ROAD LANDFILL SITE

LOCATION: MORaine, OHIO

DRILLING METHOD: CABLE TOOL

DATES OF COMPLETION: 8/28/89 - 9/7/89

DRILLING CONTRACTOR: MID-EASTERN GEOTECH

GEOLOGIST: SHIELDS

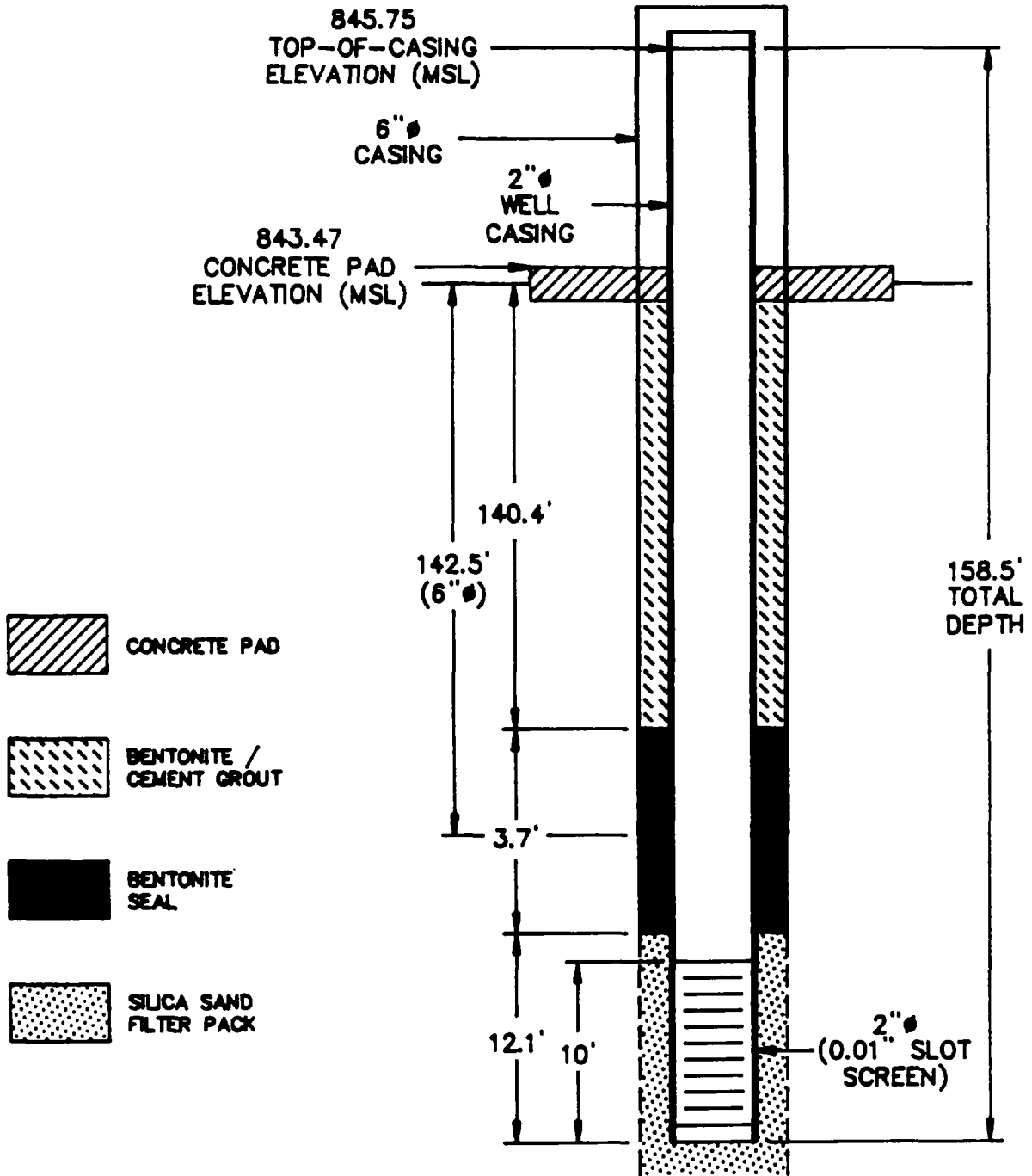

ALL DEPTHS ARE APPROXIMATE



McLAREN/HART

MONITORING WELL MW-3A

PROJECT: CARDINGTON ROAD LANDFILL SITE

LOCATION: MORaine, OHIO

DRILLING METHOD: CABLE TOOL

DATES OF COMPLETION: 7/5/90 - 7/7/90

DRILLING CONTRACTOR: BOWSER-MORNER

GEOLOGIST: FLEMING

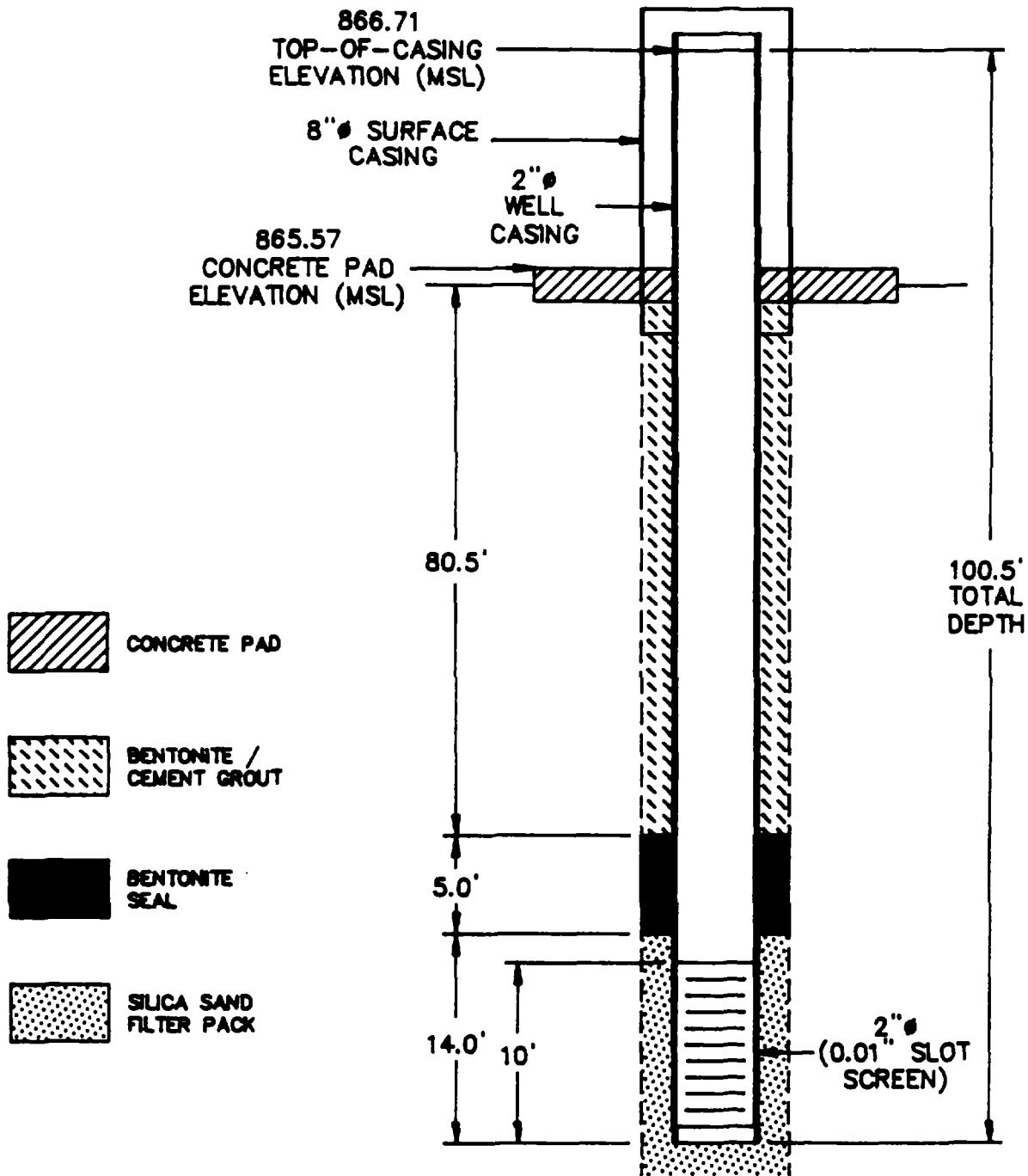

ALL DEPTHS ARE APPROXIMATE



McLAREN/HART

MONITORING WELL MW-3I

PROJECT: CARDINGTON ROAD LANDFILL SITE

LOCATION: MORaine, OHIO

DRILLING METHOD: CABLE TOOL

DATES OF COMPLETION: 7/28/89 - 8/10/89

DRILLING CONTRACTOR: MID-EASTERN GEOTECH

GEOLOGIST: ROYEX, McCREA, SHIELDS

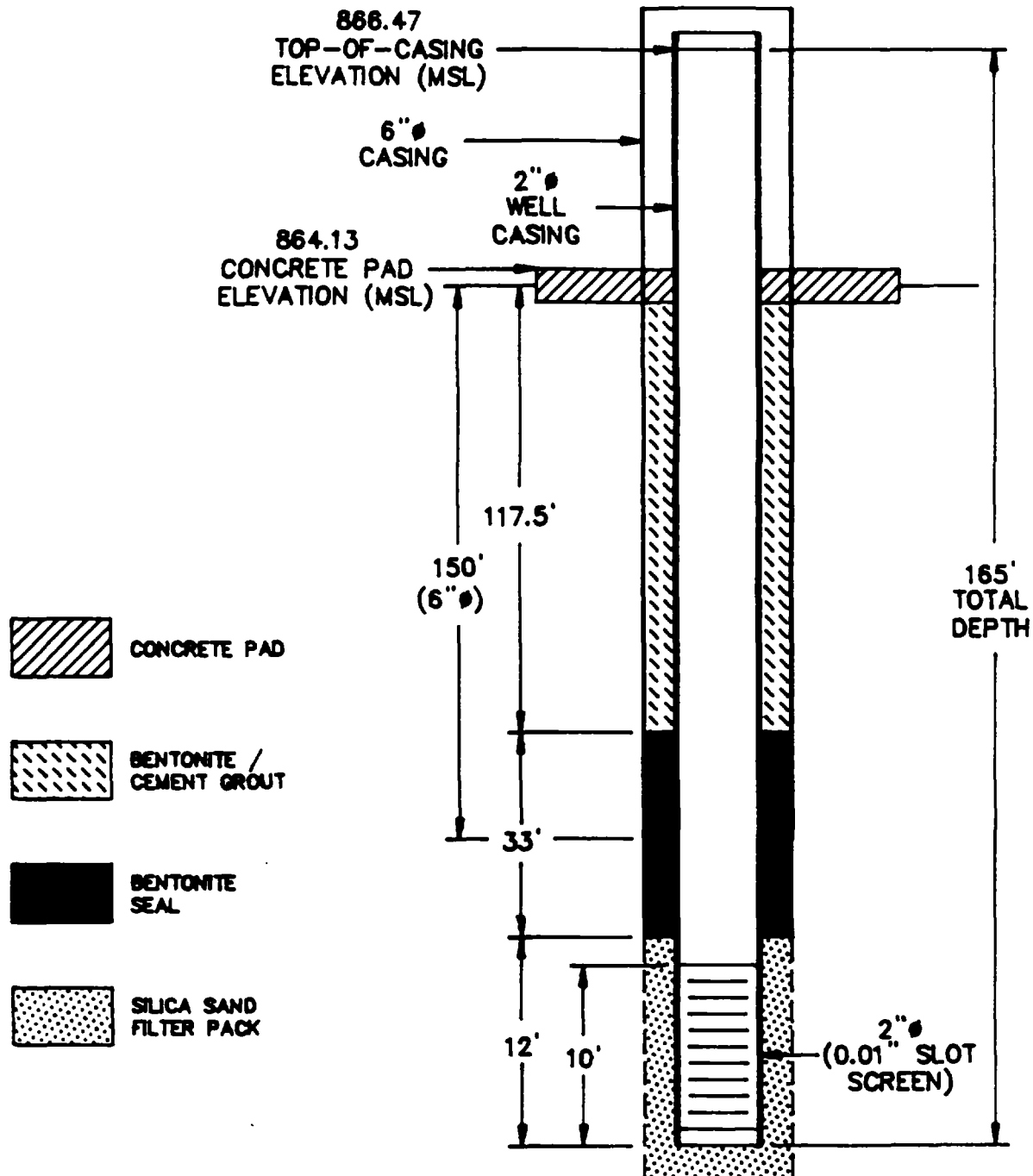

ALL DEPTHS ARE APPROXIMATE



McLAREN/HART

MONITORING WELL MW-3R

PROJECT: CARDINGTON ROAD LANDFILL SITE

LOCATION: MORaine, OHIO

DRILLING METHOD: CABLE TOOL

DATES OF COMPLETION: 11/3/89 - 12/18/89

DRILLING CONTRACTOR: MID-EASTERN GEOTECH

GEOLOGIST: McCREA, FLEMING

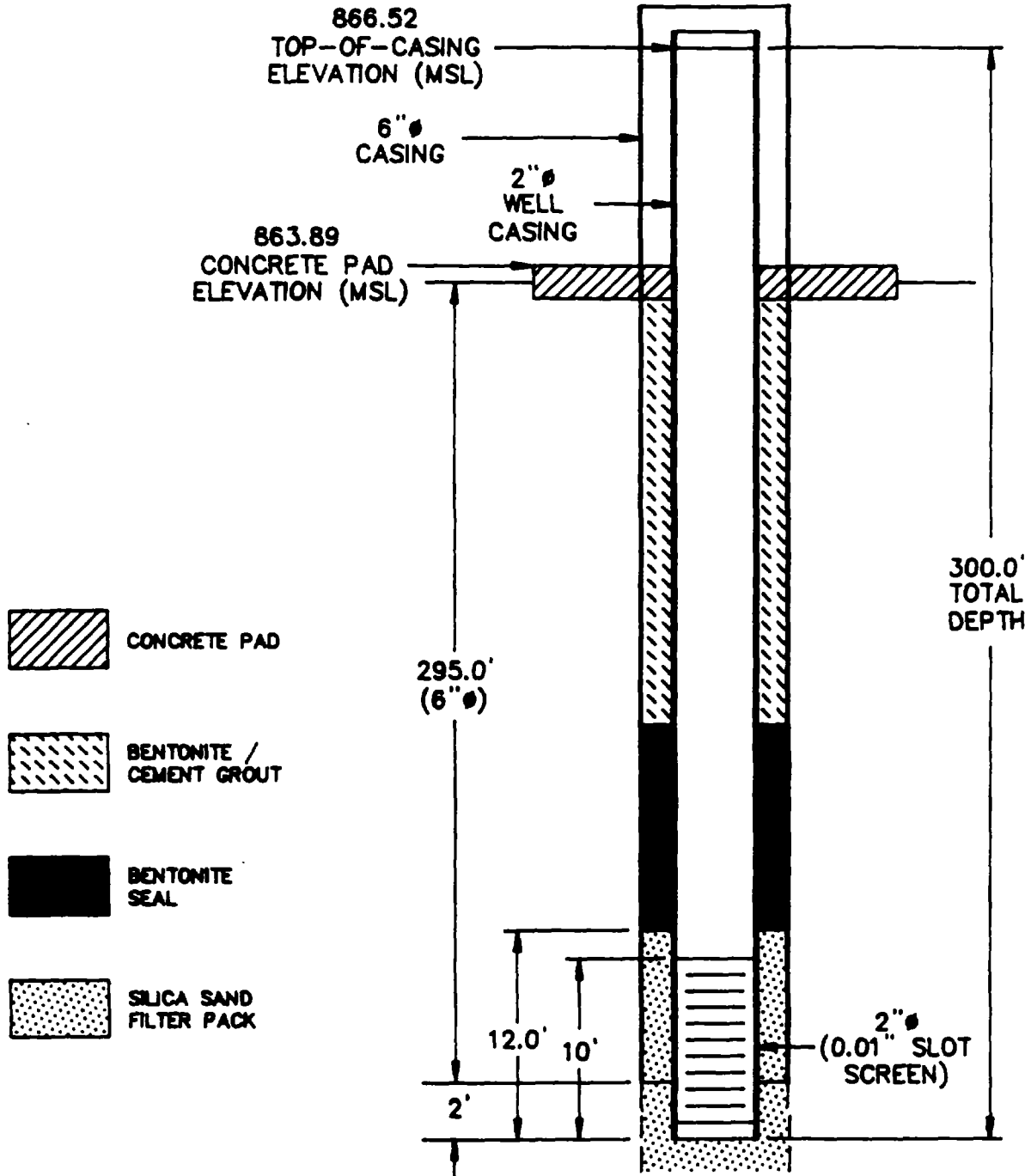

ALL DEPTHS ARE APPROXIMATE



McLAREN/HART

MONITORING WELL MW-4I

PROJECT: CARDINGTON ROAD LANDFILL SITE

LOCATION: MORaine, OHIO

DRILLING METHOD: CABLE TOOL

DATES OF COMPLETION: 8/11/89 - 8/25/89

DRILLING CONTRACTOR: MID-EASTERN GEOTECH

GEOLOGIST: McCREA, SHIELDS

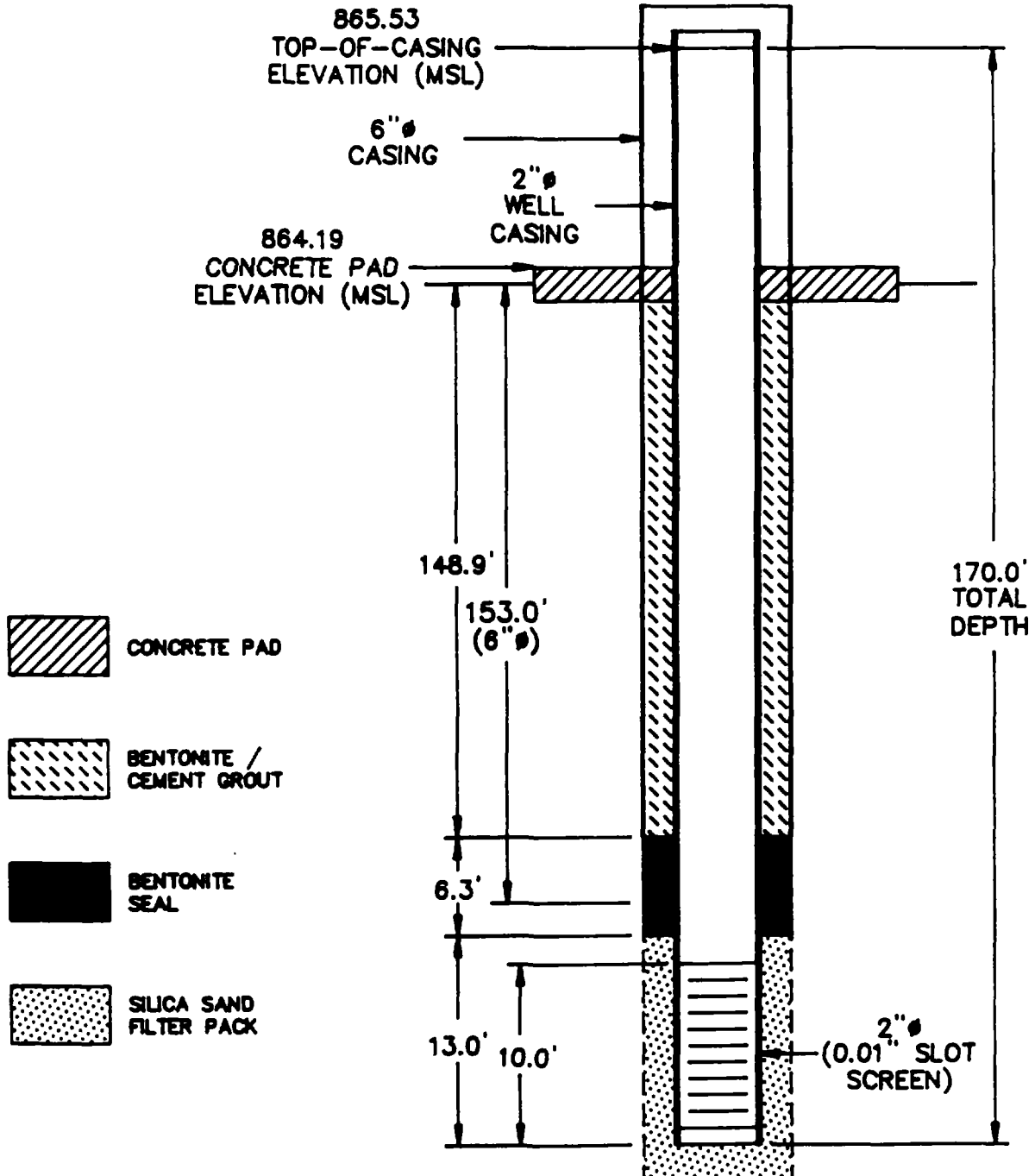

ALL DEPTHS ARE APPROXIMATE



McLAREN/HART

MONITORING WELL MW-5A

PROJECT: CARDINGTON ROAD LANDFILL SITE

LOCATION: MORaine, OHIO

DRILLING METHOD: CABLE TOOL

DATES OF COMPLETION: 7/24/89 - 7/27/89

DRILLING CONTRACTOR: MID-EASTERN GEOTECH

GEOLOGIST: SHIELDS

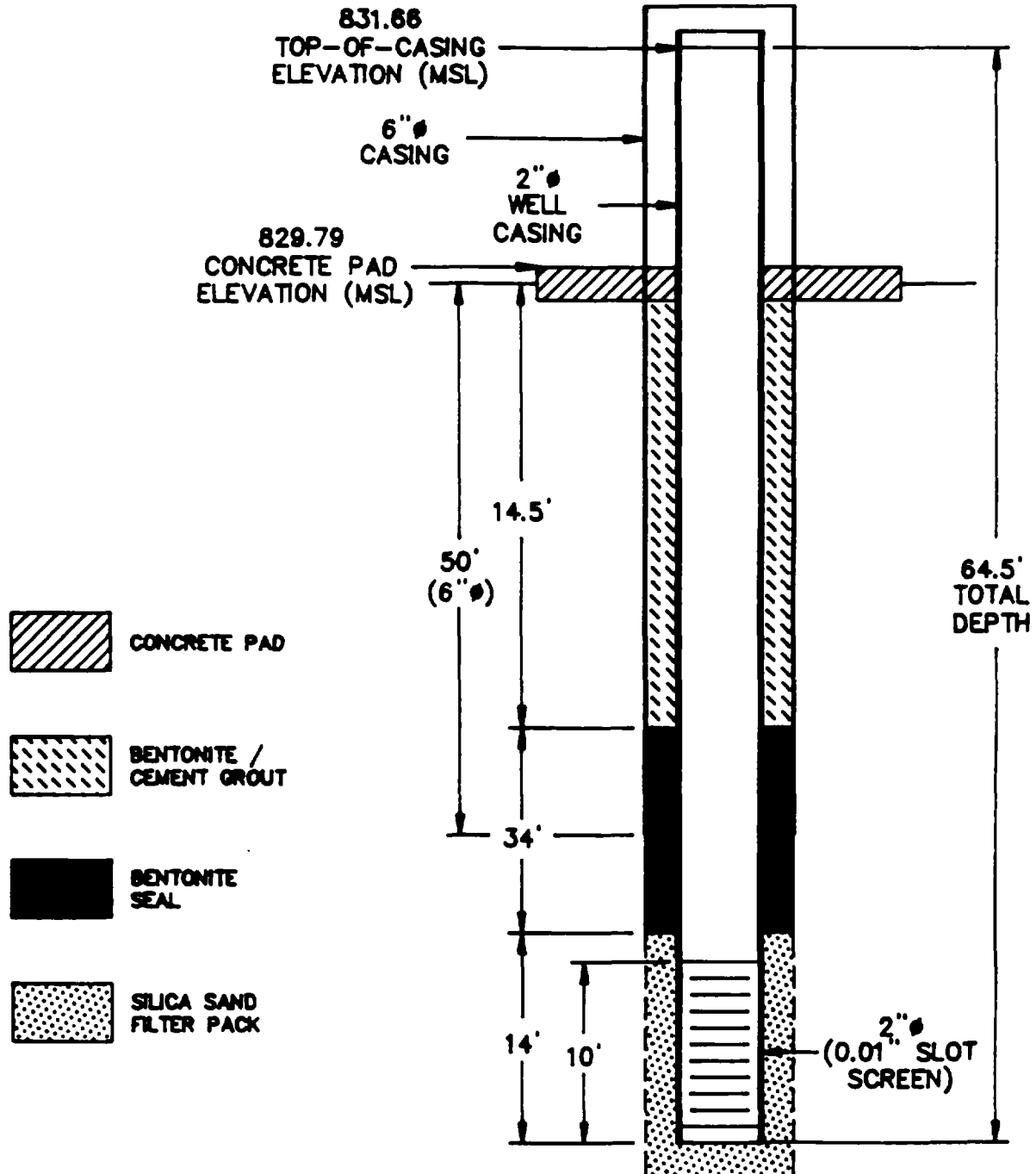

ALL DEPTHS ARE APPROXIMATE



McLAREN/HART

MONITORING WELL MW-5I

PROJECT: CARDINGTON ROAD LANDFILL SITE

LOCATION: MORaine, OHIO

DRILLING METHOD: CABLE TOOL

DATES OF COMPLETION: 10/31/89 - 11/6/89

DRILLING CONTRACTOR: MID-EASTERN GEOTECH

GEOLOGIST: FLEMING

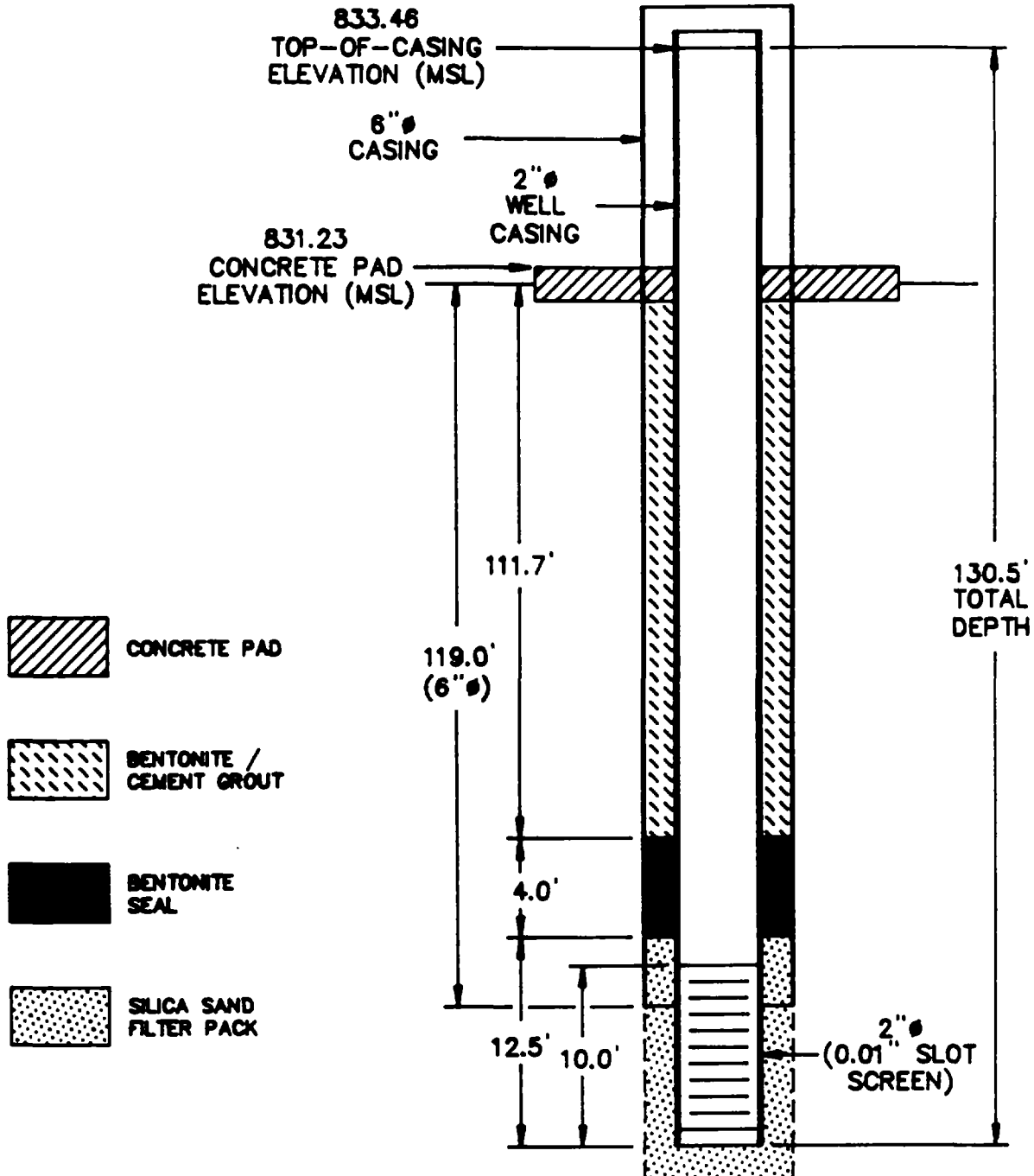

ALL DEPTHS ARE APPROXIMATE



McLAREN/HART

MONITORING WELL MW-5R

PROJECT: CARDINGTON ROAD LANDFILL SITE

LOCATION: MORaine, OHIO

DRILLING METHOD: CABLE TOOL

DATES OF COMPLETION: 9/28/89 - 10/30/89

DRILLING CONTRACTOR: MID-EASTERN GEOTECH

GEOLOGIST: McCREA, ROYEK

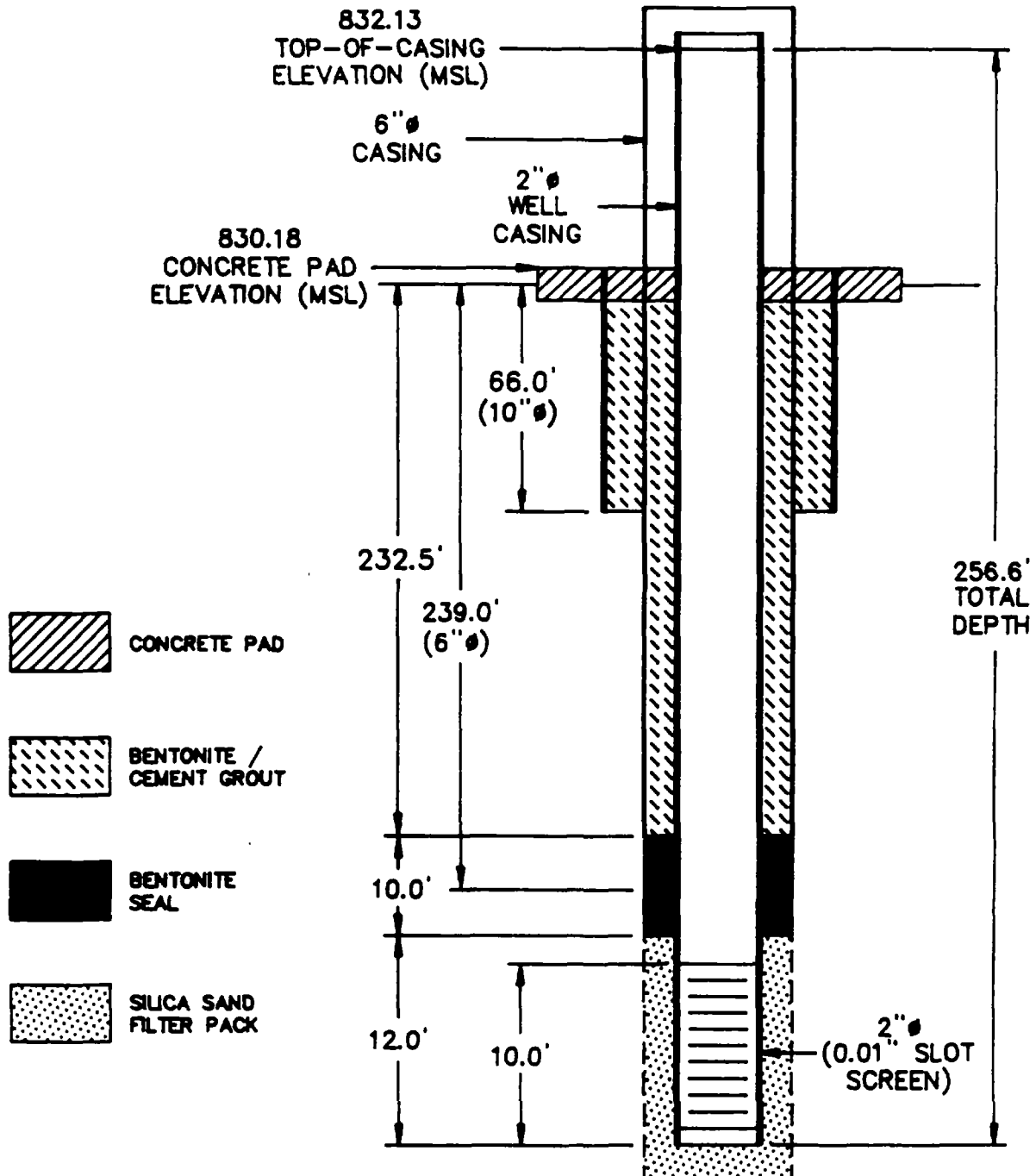

ALL DEPTHS ARE APPROXIMATE



McLAREN/HART

MONITORING WELL MW-6A

PROJECT: CARDINGTON ROAD LANDFILL SITE

LOCATION: MORaine, OHIO





DRILLING METHOD: CABLE TOOL

DATES OF COMPLETION: 7/20/89 - 7/21/89

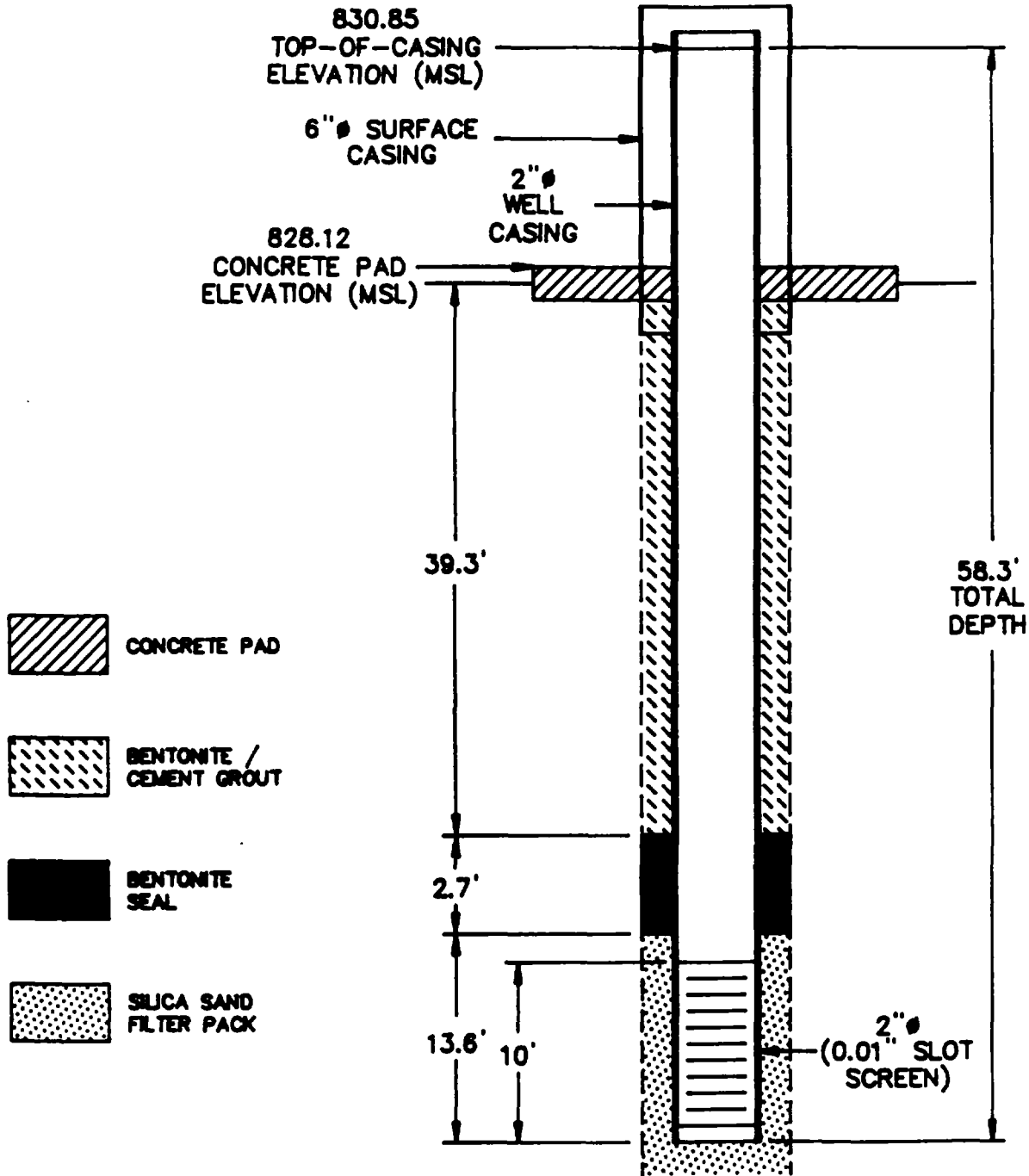
DRILLING CONTRACTOR: MID-EASTERN GEOTECH

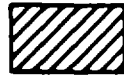
GEOLOGIST: SHIELDS



-  CONCRETE PAD
-  BENTONITE / CEMENT GROUT
-  BENTONITE SEAL
-  SILICA SAND FILTER PACK

ALL DEPTHS ARE APPROXIMATE



McLAREN/HART

MONITORING WELL MW-7I

PROJECT: CARDINGTON ROAD LANDFILL SITE

LOCATION: MORaine, OHIO

DRILLING METHOD: CABLE TOOL

DATES OF COMPLETION: 9/21/89 - 10/9/89

DRILLING CONTRACTOR: MID-EASTERN GEOTECH

GEOLOGIST: SHIELDS

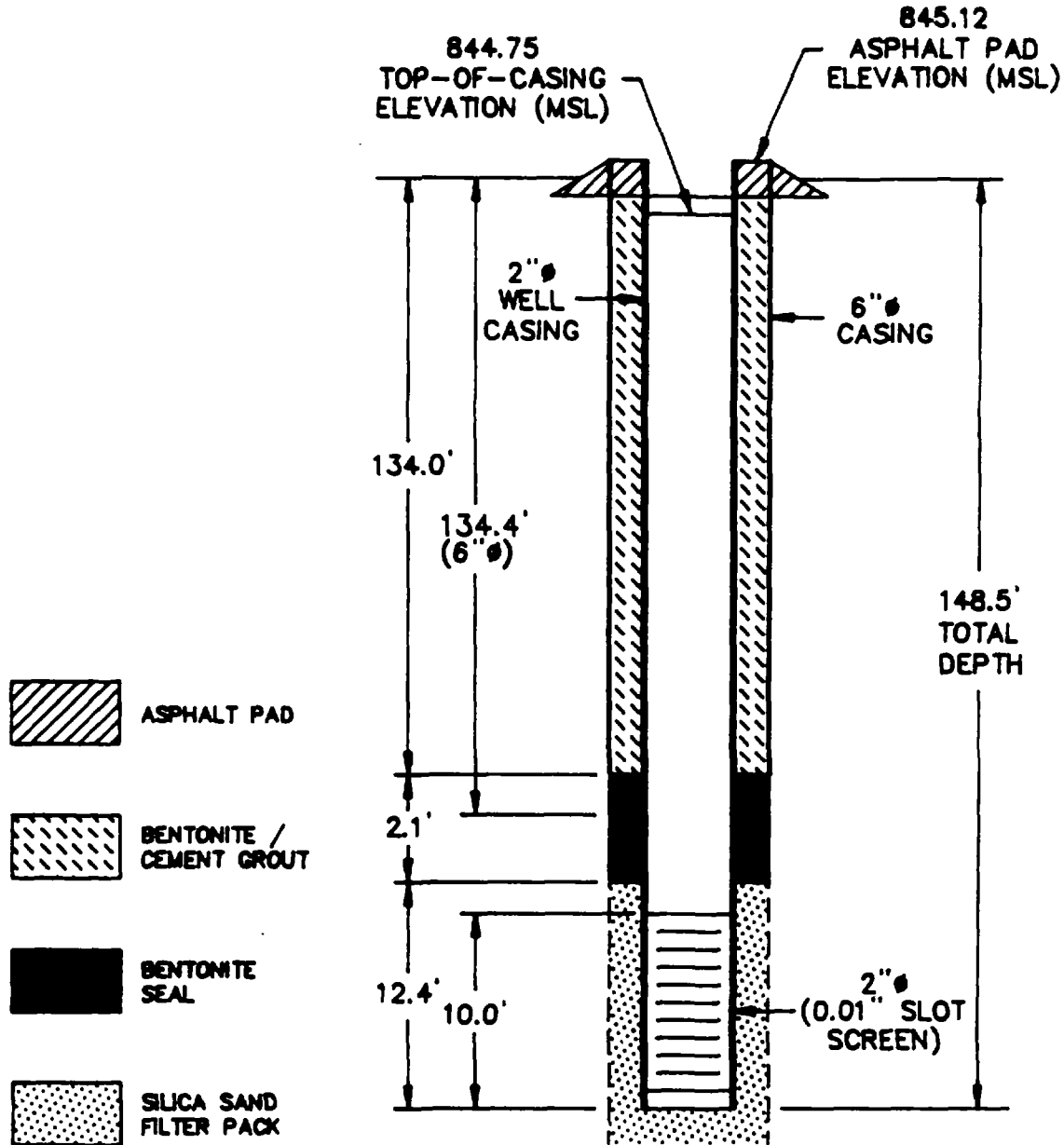

ALL DEPTHS ARE APPROXIMATE



McLAREN/HART

MONITORING WELL MW-8A

PROJECT: CARDINGTON ROAD LANDFILL SITE

LOCATION: MORANE, OHIO

DRILLING METHOD: CABLE TOOL

DATES OF COMPLETION: 7/5/90 - 7/6/90

DRILLING CONTRACTOR: BOWSER-MORNER

GEOLOGIST: HUNZEKER

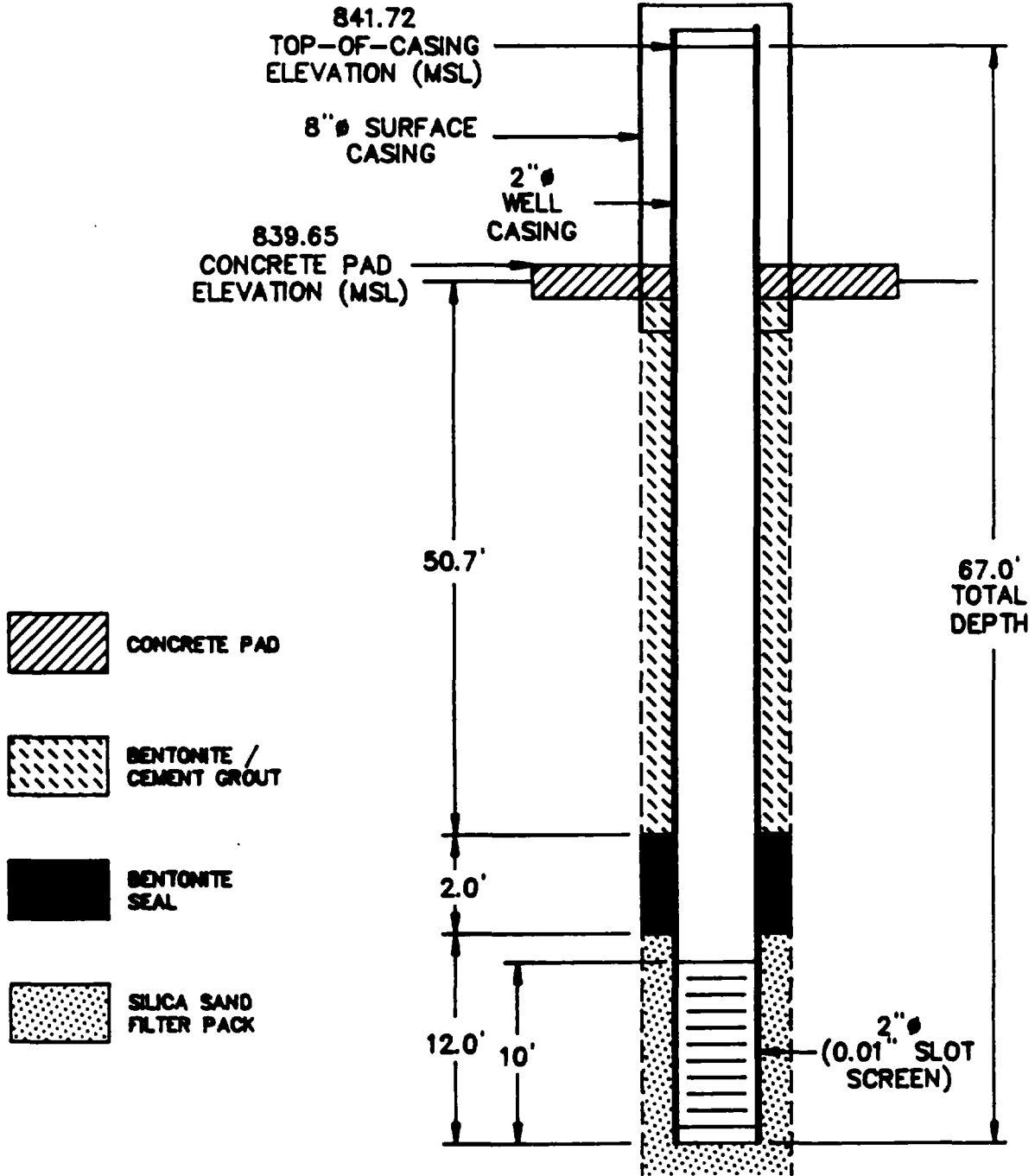

ALL DEPTHS ARE APPROXIMATE



McLAREN/HART

MONITORING WELL MW-8I

PROJECT: CARDINGTON ROAD LANDFILL SITE

LOCATION: MORaine, OHIO

DRILLING METHOD: CABLE TOOL

DATES OF COMPLETION: 6/26/90 - 6/29/90

DRILLING CONTRACTOR: BOWSER-MORNER

GEOLOGIST: FLEMING

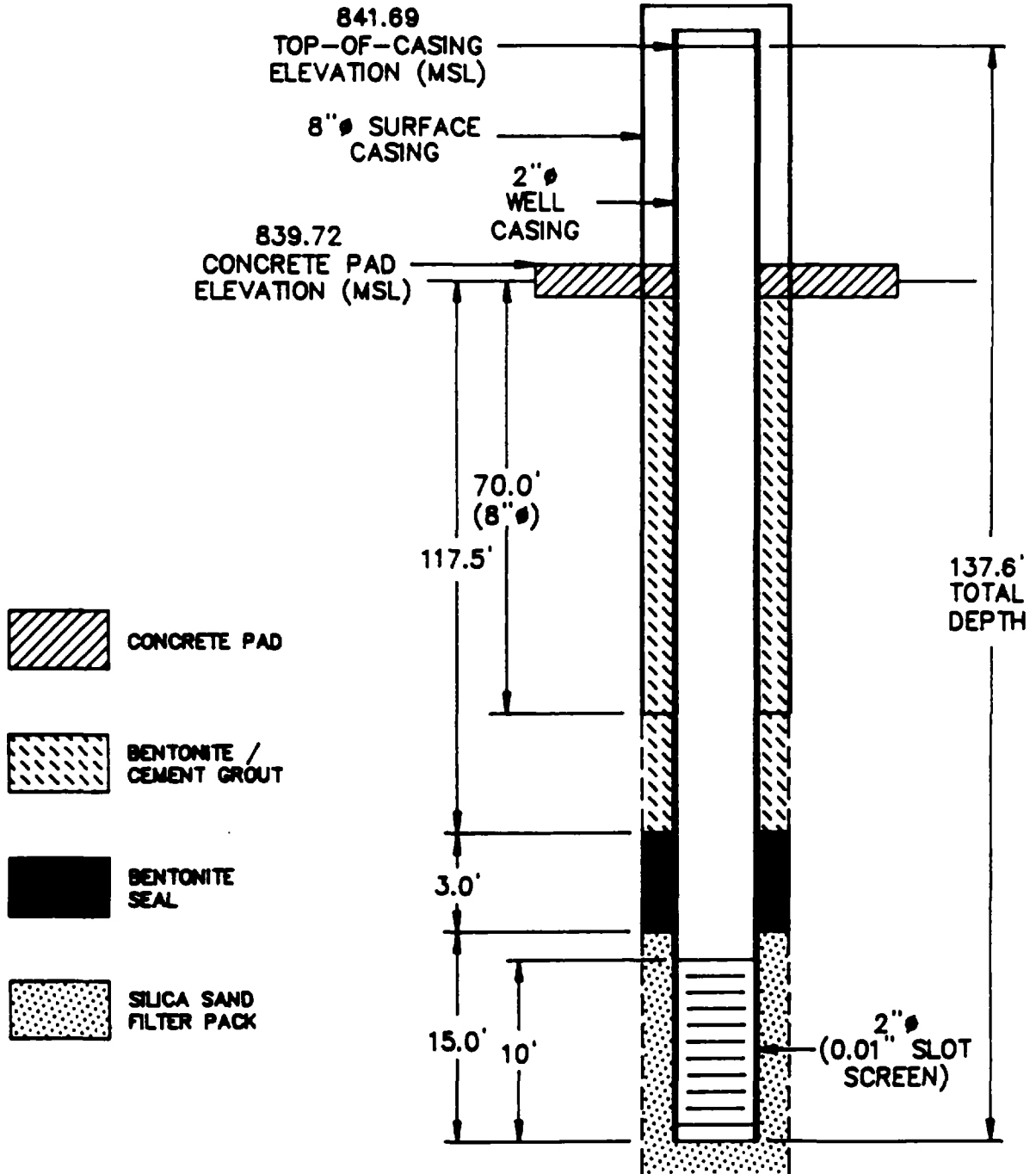

ALL DEPTHS ARE APPROXIMATE



McLAREN/HART

MONITORING WELL MW-8M

PROJECT: CARDINGTON ROAD LANDFILL SITE

LOCATION: MORaine, OHIO

DRILLING METHOD: CABLE TOOL

DATES OF COMPLETION: 6/20/90 - 6/26/90

DRILLING CONTRACTOR: BOWSER-MORNER

GEOLOGIST: FLEMING

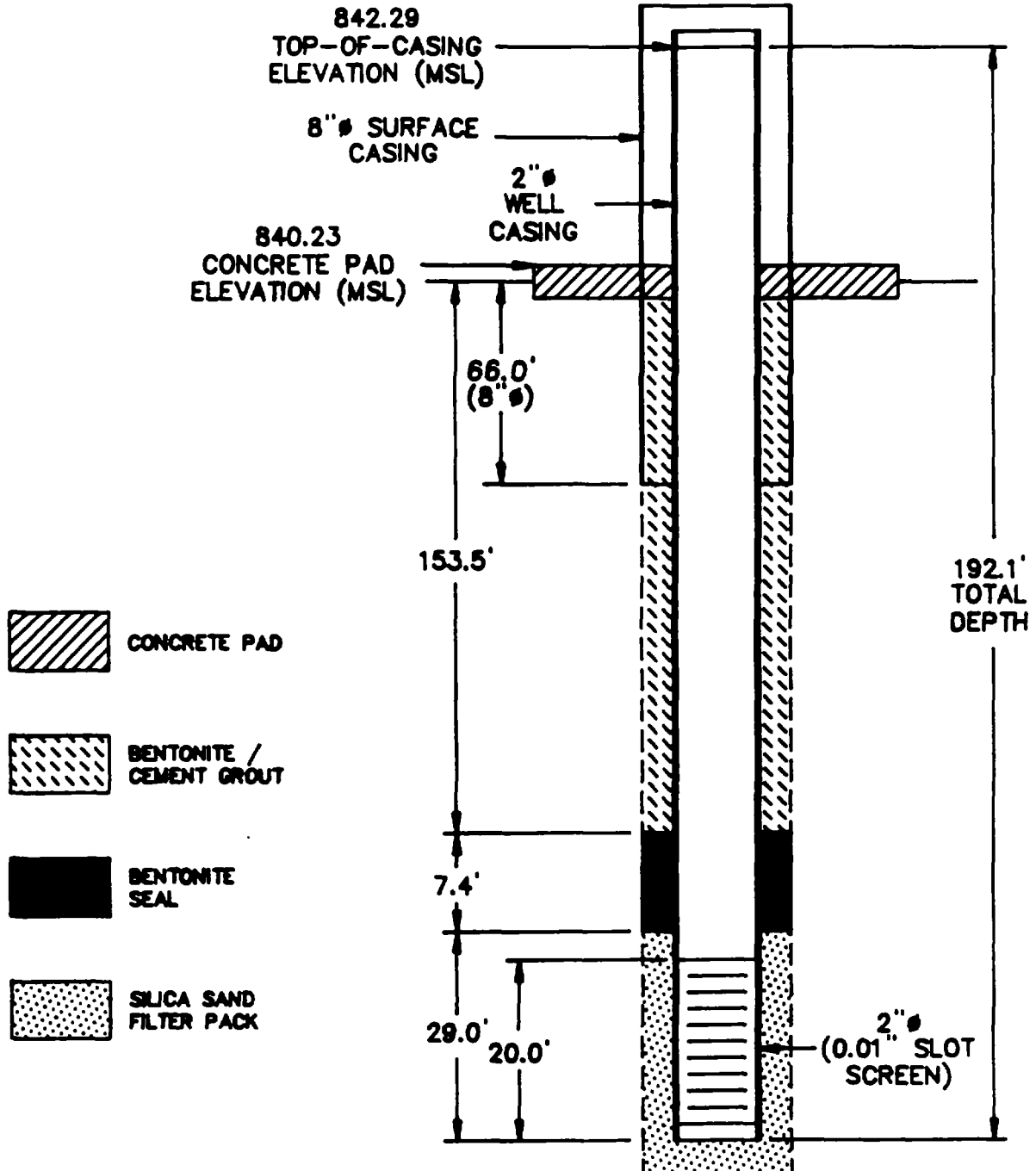

ALL DEPTHS ARE APPROXIMATE



McLAREN/HART

MONITORING WELL MW-9I

PROJECT: CARDINGTON ROAD LANDFILL SITE

LOCATION: MORaine, OHIO

DRILLING METHOD: CABLE TOOL

DATES OF COMPLETION: 8/28/90 - 7/5/90

DRILLING CONTRACTOR: BOWSER-MORNER

GEOLOGIST: HUNZEKER

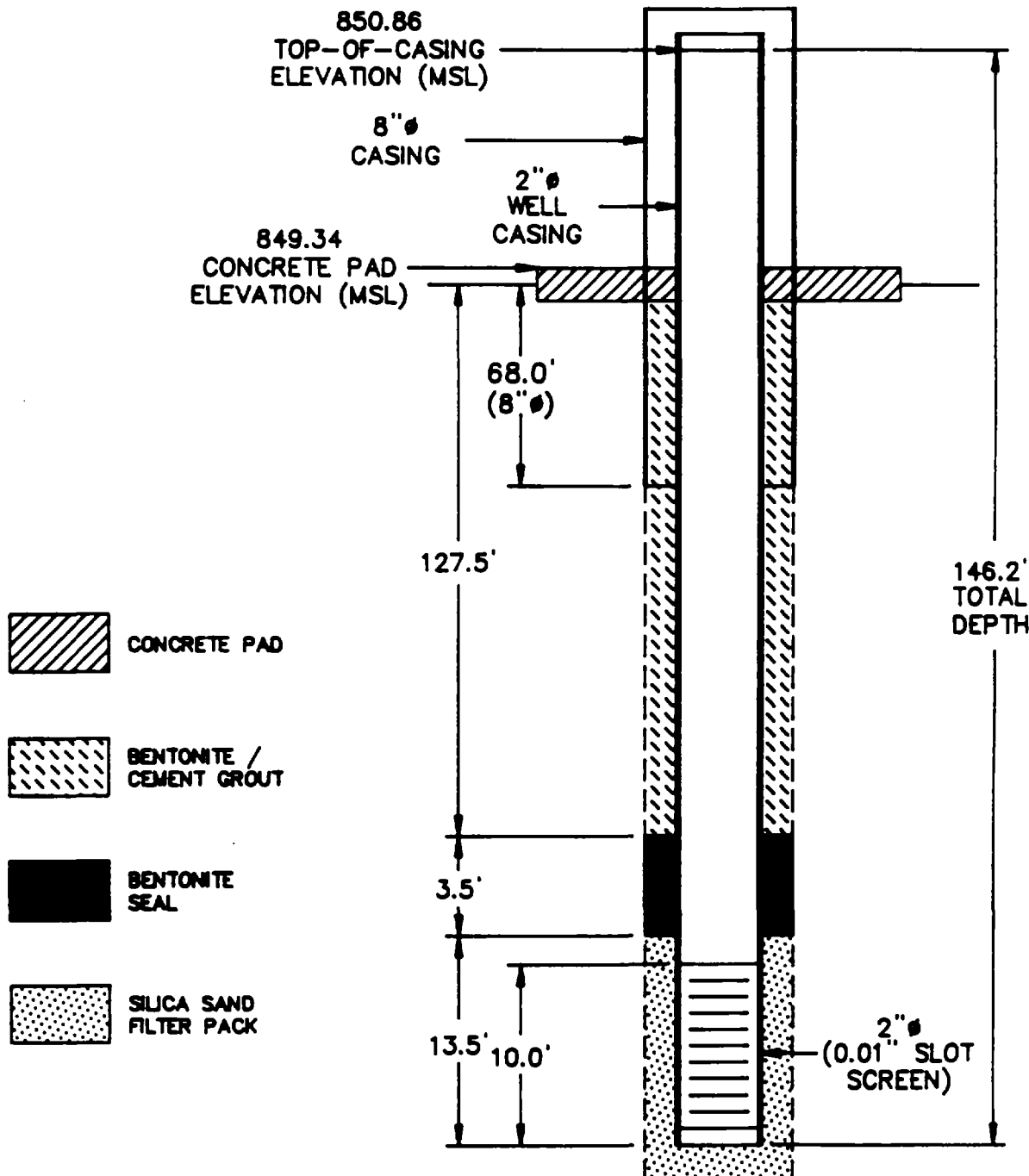

ALL DEPTHS ARE APPROXIMATE



McLAREN/HART

MONITORING WELL MW-9M

PROJECT: CARDINGTON ROAD LANDFILL SITE

LOCATION: MORaine, OHIO

DRILLING METHOD: CABLE TOOL

DATES OF COMPLETION: 6/20/90 - 6/26/90

DRILLING CONTRACTOR: BOWSER-MORNER

GEOLOGIST: HUNZEKER

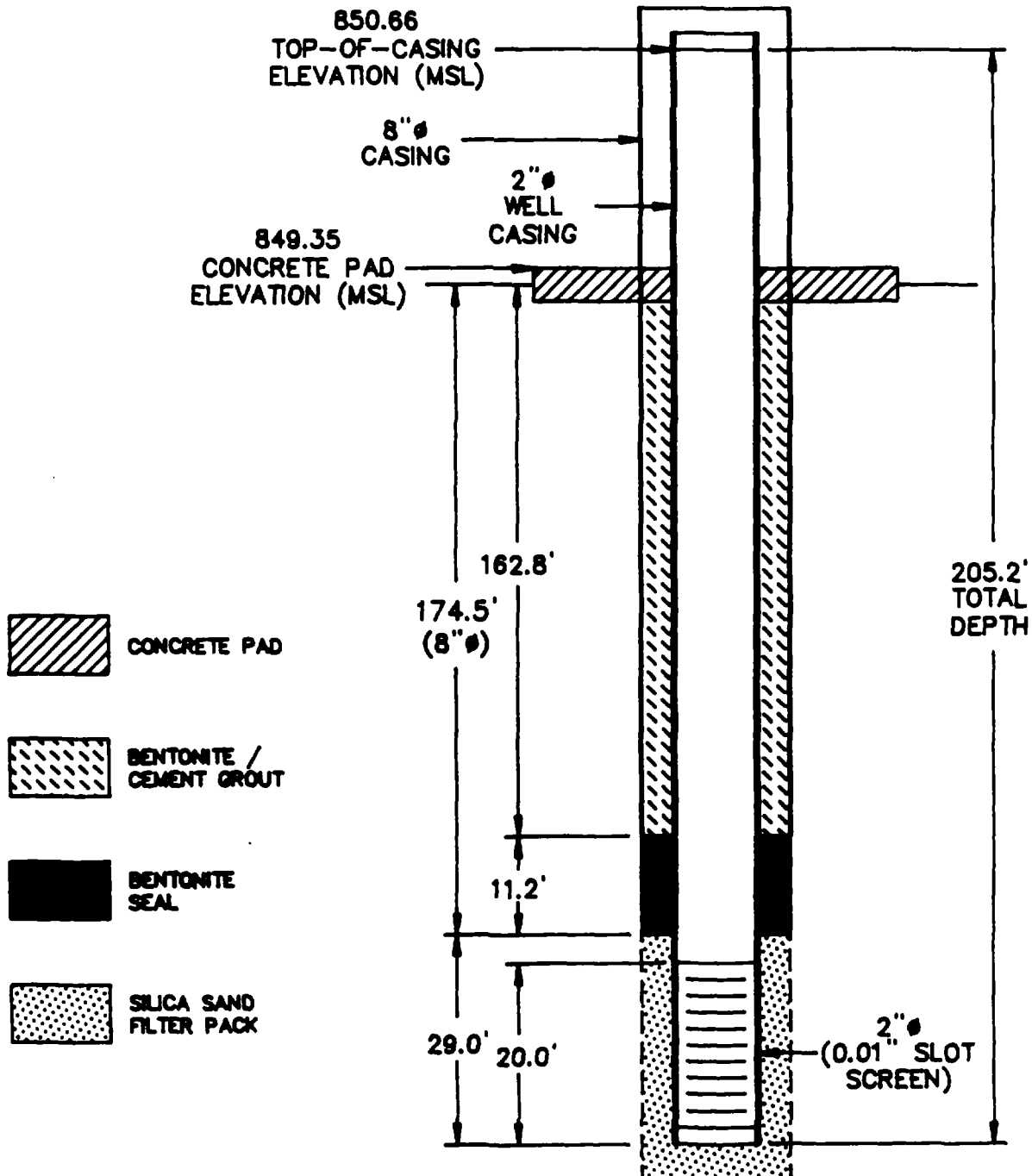

ALL DEPTHS ARE APPROXIMATE

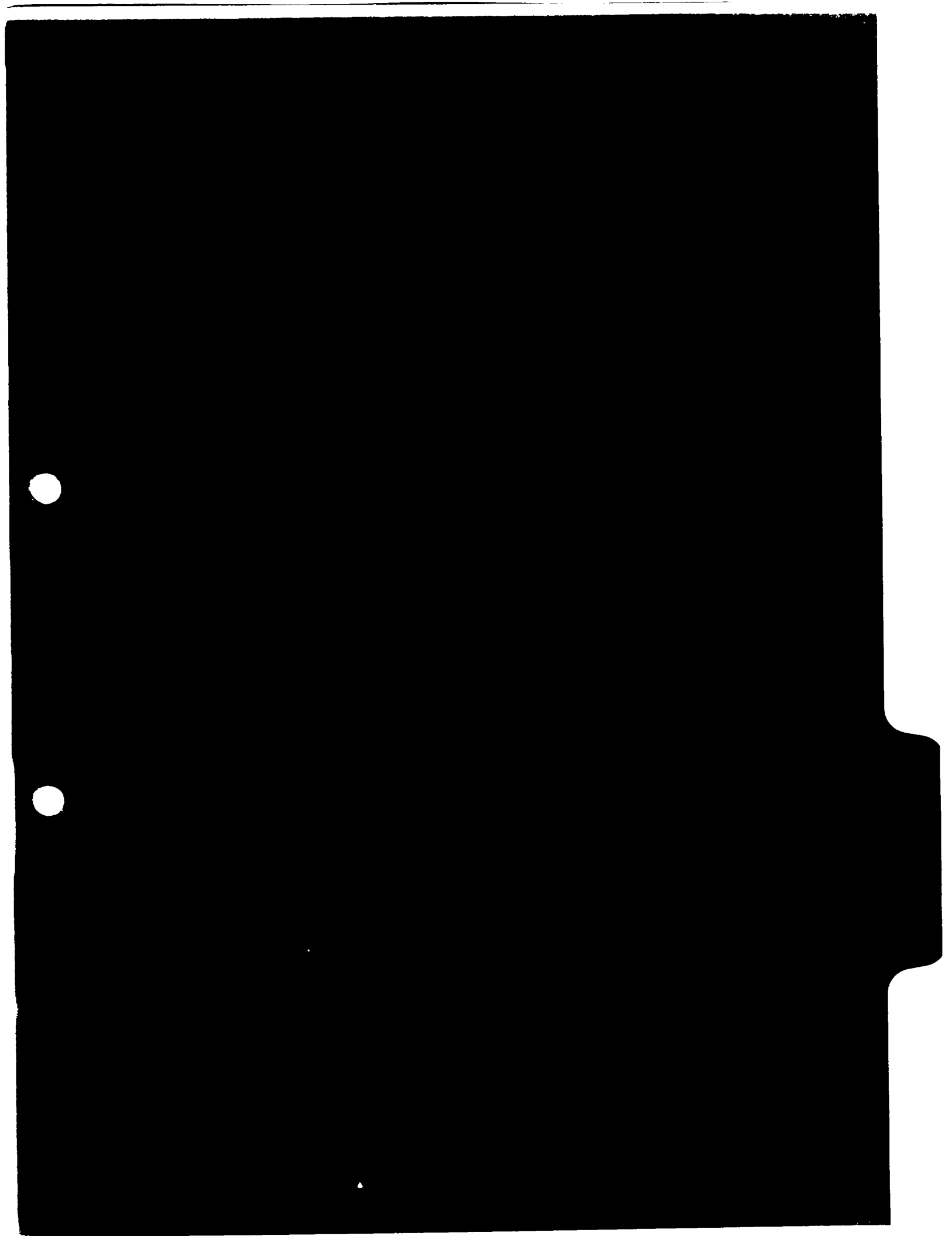

APPENDIX D

**QA/QC AND DATA SUFFICIENCY
TECHNICAL MEMORANDUM**

**QUALITY ASSURANCE/QUALITY CONTROL
and DATA SUFFICIENCY
TECHNICAL MEMORANDUM
CARDINGTON ROAD LANDFILL SITE
MORaine, OHIO**

1.0 INTRODUCTION

The Remedial Investigation/Feasibility Study (RI/FS) Work Plan for the Cardington Road Landfill Site (herein after referred to as "the Site") presented a detailed series of field activities designed to evaluate the potential presence of chemical constituents, if any, at the Site and to assess the potential routes of chemical constituent migration from the Site. One of the RI activities defined as Task 3.0 in the RI Work Plan included a detailed quality assurance/quality control (QA/QC) evaluation of the analytical data collected during the various RI field activities including but not limited to the ground water, sediments, seeps, surface water, and intrusive borings investigations, and a data sufficiency evaluation of the validated data.

This Technical Memorandum summarizes the various procedures followed during the data validation, the QA/QC parameters reviewed, laboratory QC procedures pertinent to the validation, specific concerns identified during the data validation, and the results of the data sufficiency evaluation. These activities generally comply with the specifications presented in the RI/FS Work Plan, the Sample Analysis Plan (SAP), and the Quality Assurance Project Plan (QAPP) revised and submitted by Hart Engineers Midwest, Inc. in 1989 and the USEPA documents on Laboratory Data Validation for Evaluating Organics, Pesticides, and Inorganic Analyses. Any deviations from the procedures outlined in these documents are noted.

1.1 TASK PURPOSE AND SCOPE

The primary objectives of Task 3.0 of the RI Work Plan are to evaluate the QA/QC evaluation of the analytical procedures to ensure the validity of the analytical results and to evaluate the sufficiency of the data. The laboratory analytical results were subjected to a QA/QC evaluation to determine whether the results

have met the requirements outlined in the project SAP and QAPP and the USEPA documents for validation and are within acceptable limits. The validated data from each media were then compared to determine whether sufficient information is present to address the project objectives established for the RI Work Plan. The objectives addressed by the data sufficiency review include:

- o the determination of whether ground water contamination has occurred on-site or off-site;
- o the determination of the concentrations and vertical and horizontal contamination, if any;
- o the identification of the presence or absence of contaminated soil and/or sediment on-site or adjacent to the Site;
- o the identification of the presence or absence of site related air contamination on or adjacent to the Site;
- o the identification of the physical site features that may affect contaminant migration, containment, or remediation; and,
- o the development of sufficient data and information to support the Risk Assessment and the Feasibility Study.

The scope of this task focussed on evaluating and organizing the information and data collected during the site investigation in such a way that the relationships between site investigations for each site media would be assessed. The detailed findings of the individual media investigations are presented in separate Technical Memoranda and are not repeated herein. The purpose of the data sufficiency evaluation in this Technical Memorandum is to provide a brief assessment of the applicability of the data for purposes of determining the conditions resulting from the Site.

Each of the individual tasks supplied information on specific media at the Site. The purpose of each investigation can be summarized as follows:

**QUALITY ASSURANCE/QUALITY CONTROL
and DATA SUFFICIENCY
TECHNICAL MEMORANDUM
CARDINGTON ROAD LANDFILL SITE
MORaine, OHIO**

Prepared For:

**CARDINGTON ROAD COALITION
DAYTON, OHIO**

Prepared By:

**McLAREN/HART ENVIRONMENTAL ENGINEERING CORPORATION
PENN CENTER WEST III, SUITE 106
PITTSBURGH, PENNSYLVANIA 15276**

APRIL 1991

TABLE OF CONTENTS

SECTION	PAGE NO.
1.0 INTRODUCTION	1
1.1 Task Purpose and Scope	1
2.0 DATA VALIDATION METHODOLOGY 112	4
2.1 Field Quality Control Protocols	4
2.2 Data Provided by Analytical Laboratory	4
2.3 Data Completeness Review and Validation Methodology	5
3.0 DATA VALIDATION RESULTS	9
3.1 Volatile Organic Parameters	9
3.2 Semi-Volatile Organic Parameters	9
3.3 Pesticides/PCB Parameters	10
3.4 Inorganic Parameters	11
4.0 DATA SUFFICIENCY REVIEW	13

- o Terrain conductivity survey data would be used to define the waste boundaries at the site, to determine likely locations of high conductivity materials within the waste, and to determine possible intrusive boring locations.
- o On-site vent gas, vent liquids, and leachate head well fluids data would be used to characterize the chemical nature of the waste in the landfill.
- o Quantitative ground water level and quality data would be used to establish the site specific hydrogeologic and ground water quality and the potential chemical migration pathways, if any.
- o Qualitative residential/production well water level and quality data would be used to evaluate the present and potential effects of the site on the existing residential and production well water quality in the study area. Also a comparison analysis would be performed between the chemicals potentially emanating from the Site and the water quality of the existing wells.
- o Quantitative surface soil and sediment data would be used to determine the presence or absence or extent of on-site and off-site soil and sediment contamination due to site activities.
- o Soil samples from the cover materials were tested to assess the potential for leachate generation and migration from the Site.
- o Quantitative surface water quality from the ponds and the identified seeps would be used to determine the presence or absence of on-site and off-site surface water contamination which may be related to the prior site activities.

2.0 DATA VALIDATION METHODOLOGY 112

2.1 FIELD QUALITY CONTROL PROTOCOLS

Field duplicates, field blanks, and trip blanks were collected and submitted to the analytical laboratory to provide a means to assess the quality of the analytical data generated from the sampling program. Field duplicate samples were assessed to determine sampling and analytical reproducibility. Field and trip blank samples were assessed to determine if procedural contamination and cross-contamination occurred during sample shipment and storage.

In general, one trip blank was collected for each sample shipping container holding liquid and air samples for volatile organic compounds (VOC) analyses. One field duplicate sample was collected for every ten investigative samples collected during each sediment, soil and air sampling events. No field and trip blanks were collected for soil and sediment samples.

Field measurement data generated during many of the field activities incidental of analytical testing included recording sampling elevations, determining well depths, and verifying development and presampling purge volumes. The general QA objective for field measurement data is the generation of reproducible and comparable measurements to a degree of accuracy consistent with the intended use of the data.

2.2 DATA PROVIDED BY ANALYTICAL LABORATORY

The overall QA objective is to develop and implement procedures which would provide analytical data of a sufficient quality consistent with its intended use and which meets the requirements established for accuracy, precision, sensitivity, completeness, representativeness, and comparability.

The analytical laboratory was required to provide sufficient information on the analytical test methods and results along with the appropriate data quality notations for each sample submitted. The laboratory personnel reviewed the appropriate quality control data to assure the validity of the analytical results.

All analytical and quality assurance procedures performed by the laboratory followed the guidelines established in the SAP and QAPP. A narrative consisting of a statement of samples received, description of any deviation from the QAPP, explanation of qualification regarding data quality, reanalyses performed, description of difficulties encountered with sample shipment such as broken samples or exceedance of holding times, and any other significant items encountered during analyses were provided with each data package. The analytical and laboratory quality assurance documentation provided was then reviewed by McLaren/Hart for data completeness review and validation.

2.3 DATA COMPLETENESS REVIEW AND VALIDATION METHODOLOGY

Upon receipt of each data package from the analytical laboratory, McLaren/Hart conducted an evaluation of data accuracy, precision, sensitivity, and completeness based on the requirements outlined in the SAP and QAPP, as well as the protocols established by USEPA. McLaren/Hart conducted a systematic review of the data for compliance with established QA/QC criteria based on the spike, duplicate, and blank analytical results provided by the laboratory. Any out-of-control data points, data omissions, and data deficiencies by the laboratory were identified during the review and validation activities. The data validation determined data usability and the extent of data deficiency. Quality assurance data validation summary reports were prepared for each analytical data package. Reanalysis of specific samples were performed, if deemed necessary by the laboratory and McLaren/Hart.

The analytical laboratories used are participants in the USEPA Contract Laboratory Program (CLP) for organic and inorganic testing. The level of QC effort conformed to the protocols specified under the CLP program for the Routine Analytical Services (RAS) air parameters to be tested. The level of QC effort for testing of inorganics (metals and cyanide) conformed to the protocols in SOW-787. The level of QC effort for testing of target compound list (TCL) organics including volatiles, semi-volatiles, and pesticides/PCBs conformed to the protocols in SOW-787, EPA TO-14, EPA 600, and soil-gas sampling and analysis (SOP). The level of QC effort for testing of TCL organics for drinking water criteria

conformed to protocols in 40 CFR Part 136, October 26, 1984, entitled "Guidelines for Establishing Test Procedures for the Analysis of Pollutants Under the Clean Water Act; Final Rule and Interim Final Rule and Proposed Rule" or other pertinent guidance as discussed with USEPA Region V personnel from the laboratory chemistry QA/QC group. The level of QC effort for testing of methane and asbestos in air samples conformed to the protocols in NIOSH, "Manual of Analytical Methods".

The laboratories were required to provide data meeting QA acceptance criteria for ninety-five percent or more of all samples tested. Valid data (i.e., all QC parameters within control limits) were required for all samples designated as "background" samples. The laboratory was required to analyze an undigested control standard at the beginning and end of each run to evaluate instrument performance. Analysis of a digested acidified reagent water laboratory blank was required with each run to check the system for contaminants and interferences.

All data generated included data flags provided by the laboratory as well as additional comments by the Data Reviewer. The laboratory-provided data flags include such items as: the concentration below required detection limit; estimated concentrations due to the poor spike recovery; and, concentration of chemicals also found in the laboratory blank. The McLaren/Hart Data Reviewer comments indicated whether the data are: usable as a quantitative concentration; usable with caution as an estimated concentration; or, unusable due to out-of-control QC results. The final qualifiers presented on the summary tables in the individual Technical Memoranda included those from the Data Reviewer. Copies of the Data Validation Summary sheets are included in Attachment B.

Non-conformance with the established quality control procedures by the laboratory was identified and controlled. No additional work which was dependent on the non-conforming activities were performed until the non-conformance was corrected. Corrective actions may have included but are not limited to:

- o re-evaluating the samples if holding time criteria and sample volume permit;

- o resampling and analyzing;
- o evaluating and amending sampling and analytical procedures;
- o accepting data with an acknowledged level of uncertainty; and/or,
- o discarding the data.

In general, the guidelines and procedures used to validate and evaluate the laboratory data are described in the USEPA documents "Laboratory Data Validation Functional Guidelines for Evaluating Organic Analyses" dated February 1, 1988 and "Laboratory Data Validation Functional Guidelines for Evaluating Inorganic Analyses" dated July 1, 1988. Copies of these documents are included in Attachment A.

These guidelines are designed to offer guidance in laboratory data validation and evaluation. Where specific Standard Operating Procedures (SOP) exist, definitive performance requirements which are not sample dependent have been established. These requirements cover specific areas including blanks, calibration standards, calibration verification standards, laboratory control standards, interference check standards, performance evaluation standard materials, and tuning. Areas where no SOPs have been established and which are sample dependent, only general guidance are given.

When evaluating data validity, information including the number of samples, sample number, sample matrices, blanks, field duplicates, field spikes, shipping dates, and QC samples, if applicable, are essential for review. All criteria affecting data validity must be evaluated. In instances where the contractual requirements identified in the SAP and QAPP differ from the functional guidelines for these items, both sets of requirements are reviewed.

For organic analyses, the following requirements must be reviewed and evaluated:

- o Holding Times;
- o GC/MS Tuning;
- o Calibration;

- o Blanks;
- o Surrogate Recovery;
- o Matrix Spike/Matrix Spike Duplicate;
- o Field Duplicates;
- o Internal Standards Performance;
- o TCL Compound Identification;
- o Compound Quantitation and Reported Detection Limits; and,
- o Tentatively Identified Compounds.

For inorganic analyses, the following requirements must be reviewed and evaluated:

- o Holding Times;
- o Calibration - Initial and Continuing Calibration Verification;
- o Blanks;
- o ICP Interference Check Sample;
- o Laboratory Control Sample;
- o Duplicate Sample;
- o Matrix Spike Sample;
- o Furnace Atomic Absorption QC;
- o ICP Serial Dilution;
- o Sample Result Verification; and,
- o Field Duplicates.

For pesticide analyses, the following requirements must be reviewed and evaluated:

- o Holding Times;
- o Pesticide Instrument Performance;
- o Calibration;
- o Blanks;
- o Surrogate Recovery;
- o Matrix Spike/Matrix Spike Duplicate;
- o Field Duplicates;
- o Compound Identification; and,
- o Compound Quantitation and Reported Detection Limits.

Once the data have been reviewed and evaluated, data validation summary reports which detail overall deficiencies, general laboratory performance and any discernible trends in data quality are prepared. Any mandatory actions which may be required such as reanalyses or submittal of corrected forms are specified on the summary reports. A contract laboratory submitting data which are out of specification may be required to rerun or resubmit data; data which do not meet specified requirements are never fully acceptable. The only exception is if the nature of the sample itself limits attainment of specifications.

The USEPA documents included in Attachment A provide a detailed description of the specific validation procedures.

3.0 DATA VALIDATION RESULTS

3.1 VOLATILE ORGANIC PARAMETERS

Review of data summary reports for the volatile organic data packages indicates that the specific concerns identified during data validation typically occurred during review of the requirements established for initial and continuing calibration and occasionally for the holding times and matrix spike/matrix spike duplicates. These concerns generally consisted of out-of-control data points and data deficiencies such as exceedance of control limits for percent differences for individual compounds during calibration, exceedance of percent relative standard deviation (RSD) for specific compounds during initial calibration, exceedance of CLP holding times by one or more days in a limited number of samples for only certain parameters, and exceedance of control limits for relative percent differences (RPD) for the matrix spike/matrix spike duplicates. Evaluation of the criteria for blanks indicated various contaminants were detected in blanks for several of the data packages. For two of the data packages, methylene chloride was detected in two of the method blanks. Validation results indicated that should the concentrations of methylene chloride in samples associated with the blanks occur at levels less than ten times the concentration detected in the blanks, then the data should be adjusted to indicate results are below detection limits.

All validated data was flagged with the appropriate qualifiers. The "J" qualifier indicated estimated data; QA/QC parameter(s) were outside acceptable limits and data was semi-quantitative. The "Q" qualifier indicated the data was below contract required quantitation limit; data is qualitative only. The "R" qualifier indicates unusable data. No analytical results were deemed unusable as a result of the data validation.

3.2 SEMI-VOLATILE ORGANIC PARAMETERS

Review of the data summary reports for the semi-volatile organic data packages indicates that the specific concerns identified during data validation typically occurred during review of the requirements established for the matrix spike/matrix spike duplicates, initial and continuing calibration, and surrogate recov-

ery, and occasionally in the requirements for the internal standards and holding times. These concerns typically included out-of-control data points and data differences such as exceedance of control limits of the percent differences for the matrix spike/matrix spike duplicates, exceedance of the control limits for the RSD values during the initial calibration, exceedance of the percent differences for several analytes during continued calibration, exceedance of percent surrogate recovery for several compounds, exceedance of the internal standard area, exceedance of the relative percent difference value and spike recoveries for the matrix spike/matrix spike duplicate and exceedance of holding times by one to four days for a limited number of samples. Evaluation of the criteria for blanks indicated various contaminants were detected in several of the data packages. For one of the data packages, bis(2-ethylhexyl)phthalate was detected in the method blank. Data validation results indicated that should the concentration of bis(2-ethylhexyl)phthalate in any of the samples associated with this method blank occur at levels less than ten times the concentration detected in blank, the data should be adjusted to indicate results were below the detection limit. Data was adjusted accordingly.

All validated data was flagged with the appropriate qualifiers accordingly. The "J" qualifier indicated the result were estimates only; QA/QC parameter(s) were outside acceptable limits and results were semi-quantitative. The "Q" qualifier indicates the data were below contract required quantitation limits and qualitative only. The "R" qualifier indicates the data is unusable. No unusable data was identified during the data validation. Missing information on laboratory analyses for the Group 56 semi-volatile data package was identified during data validation. Missing data sheets were subsequently reissued by the laboratory.

3.3 PESTICIDES/PCB PARAMETERS

Review of the data validation summary reports for the pesticides/PCBs data packages indicates that the specific concerns identified during the data validation typically occurred during review of the requirements established for holding times, matrix spike/matrix spike duplicates, and the initial and continuing calibration. These concerns were limited to occasional exceedance of CLP holding

times for re-extraction of matrix spike/matrix spike duplicates, occasional exceedance of control limits for percent recoveries for matrix spike/matrix spike duplicates, and occasional exceedance of the control limits for relative percent differences for the matrix spike/matrix spike duplicates.

All validated data was flagged with appropriate qualifiers. The "J" qualifier indicates the data were estimates only; QA/QC parameter(s) were outside limits and were semi-quantitative. The "Q" qualifier indicated data were below contract required quantitation limits; data were qualitative only. The "R" qualifier indicated the data were unusable.

3.4 INORGANIC PARAMETERS

Review of data summary reports for the inorganic data packages indicates that the specific concerns identified during the data validation typically occurred during review of the requirements established for blanks, duplicates, matrix spikes, ICP serial dilution, and percent recoveries for furnace AA and occasionally for the holding times and laboratory control samples. The concerns identified included: exceedance of control limits for several elements in blanks during initial and continuing calibration; exceedance of control limits for several elements in blanks during initial and continuing calibration; exceedance of control limits for several elements in duplicates; exceedance of control limits for matrix spike recoveries; exceedance of control limits for matrix spike port-digestion percent recovery for several elements; exceedance of dilution difference criteria during ICP serial dilution; exceedance of relative percent difference values for several elements in duplicates; exceedance of control limits for percent recoveries for furnace AA; and, exceedance of CLP holding times for cyanide analysis by three days for a limited number of samples.

All validated data was flagged with the appropriate qualifiers. The "J" qualifier indicated the data were estimates only; QA/QC parameter(s) were outside acceptable limits and were semi-quantitative. The "Q" qualifier indicated data were below contract required quantitation limits; data were qualitative only. The "R" qualifier indicated the data were unusable. In Groups 18, 81 and 89

inorganic data packages, the percent recovery for selenium in the furnace AA indicated interference, therefore, the data were unusable and flagged with the "R" qualifier.

4.0 DATA SUFFICIENCY REVIEW

The data collected at the Site was reviewed to determine the applicability and completeness of the data for purposes of evaluating the effects from the landfill, if any. The assessment of the data at present indicates that sufficient information has been collected from the various media to adequately assess the impacts from the landfill. The sufficiency of the data from each media is summarized below.

1. Evaluation of the geophysical data indicated that the limits of the landfill could be relatively well-defined at the north, west, and south boundaries of the landfill. On the eastern boundary of the landfill, the presence of the buildings, underground utility lines, fences, and other obstructions limited the collection of readings in this area and the complete definition of the waste boundary. Aerial photographs and old site development drawings were used to assist in the boundary definition. These photographs indicated that the eastern and possibly the southern boundaries are contiguous with other apparent fill areas used in the past. The soil gas results were also used to guide the definition of the limits of the fill. Limits of the landfill were identified in the Waste Characterization Investigation Technical Memoranda. Complete definition of the eastern boundary from activities associated with the actual operation of the Cardington Road Landfill may not be possible.
2. Information was collected from both background and down-gradient locations on the nature of the surface soils. The information available indicated that the background samples can be successfully compared to the downgradient samples to assess the impact from the landfill.
3. Data has been collected from surface water bodies that are upgradient, down-gradient, and on the Site. The data addressed both surface water and sediment quality. The assessment indicates that sufficient data has been collected so that an adequate evaluation of the impacts from the Site can be completed.

4. Ground water quality data has been collected from four different zones at the landfill. Three of these zones were originally identified in the scope of the Work Plan and wells were installed in these zones including perched areas to the west of the landfill, the intermediate or regional water table zone, and the zone of the unconsolidated materials just above bedrock. After numerous wells had been installed and monitored, the Agencies requested that two additional wells be installed in a mid-zone between the intermediate wells and the wells above bedrock. At numerous locations, multiple wells were installed so that an assessment of the vertical gradient could be completed. A maximum of four rounds of water quality data have been collected from the eleven wells that were installed at the Site initially. Two rounds of analytical data were collected from the six additional wells that were installed at the Site. With two to four rounds of analytical data collected from the wells, an assessment of the presence of compounds in these wells can be completed. The wells were installed in locations that ringed the Site so that an assessment of the flow gradients can be completed. The collection of the leachate samples from within the landfill allows for a comparison of the nature and level of constituents in the leachate versus the nature of any constituents identified in the ground water.
5. The collection of the air data from the on-site gas vents and the perimeter air samples provides adequate data for an assessment of the potential migration of constituents in the air to surrounding areas. Since the air samples from both locations were analyzed for the same parameters, an adequate comparison can be completed. As has been discussed with the Agency, some rudimentary modelling may be conducted of the migration of the gases at the vents to off-site locations.
6. Data from the on-site and off-site soil gas screening supplements the assessment of the migration of gases from the landfill. The extent of the migration appeared to be attributable primarily to methane and could be identified at the perimeters of the landfill.

7. Installation of the leachate head wells into the landfill provided data on the depth of the waste material, the nature of the waste material from visual inspection, and the composition of the leachate. This information can be adequately evaluated to assess the relationship of the Site to the ground water flow and quality.

The information collected has been sufficient to allow the completion of the draft Remedial Investigation Report and the draft Risk Assessment Report.

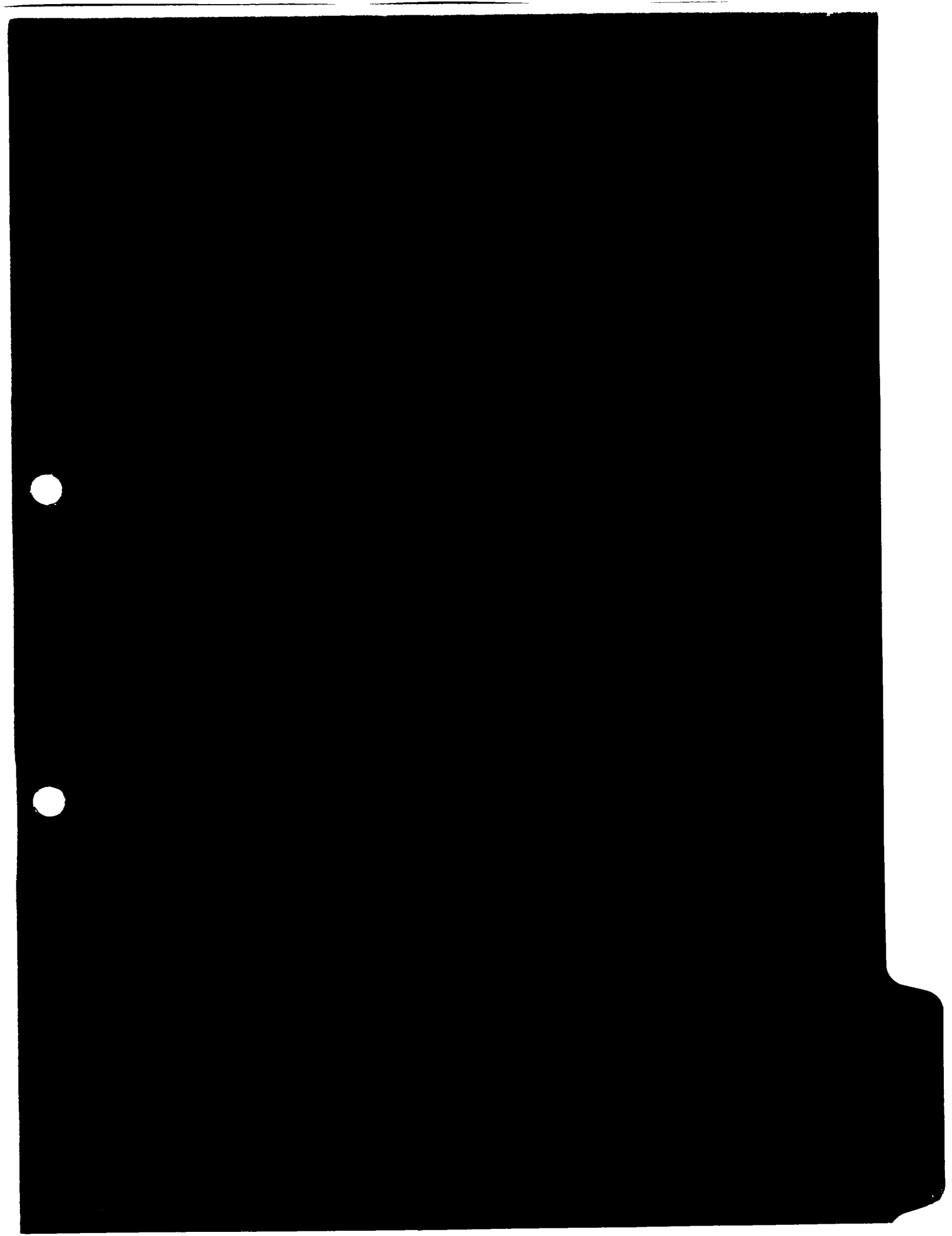

APPENDIX E

**ANALYTICAL RESULTS FOR QA/QC
SAMPLES (FIELD BLANKS, TRIP BLANKS,
MATRIX SPIKES, MATRIX SPIKE DUPLICATES)**

INORGANIC PARAMETER FIELD BLANKS
for GROUND WATER
CARDINGTON ROAD LANDFILL SITE
MORaine, OHIO

PARAMETERS	CAS NO.	SAMPLE LOCATIONS					
		FIRST QUARTER					
		MW-2IR GW02IR-01 12-13-89		MW-4IR GW04IR-01 12-14-89		MW-7IR GW07IR-01 12-12-89	
		Total	Dissolved	Total	Dissolved	Total	Dissolved
INORGANIC ANALYTES (ug/l)							
Aluminum	7429-90-5		18.3 Q	40 Q			
Antimony	7440-36-0						
Arsenic	7429-38-2						
Barium	7440-39-3		1.7 Q	1.2 Q			1.9 Q
Beryllium	7440-41-7						
Cadmium	7440-43-9						
Calcium	7440-70-2	56.5 Q	209 Q	57.8 Q	350 Q	99.8 Q	
Chromium	7440-47-3						
Cobalt	7440-48-4		3.6 Q		4.6 Q		11.2 Q
Copper	7440-50-8	51.4	47.7	44.9	40.6		
Iron	7439-89-6	8.6 Q	20.8 Q	25.6 Q	7.9 Q	15.5 Q	22.2 Q
Lead	7439-92-1					2.7 Q	12 J
Magnesium	7439-95-4		174 Q	134 Q	322 Q		468 Q
Manganese	7439-96-5	3.3 Q	6.0 Q	7.6 Q	7.4 Q	4.6 Q	14.7 Q
Nickel	7440-02-0						
Potassium	7440-09-7		1080 Q		1840 Q		9070
Selenium	7782-49-2	R		R		R	
Silver	7440-22-4			4.4 Q			
Sodium	7440-23-5			1140 Q	986 Q		4470 Q
Vanadium	7440-62-2		3.0 Q	2.8 Q	2.6 Q		11.8 Q
Zinc	7440-66-6	31.4	8.2 Q	10.2 Q	6.3 Q	81.5	27.1
Cyanide			NR		NR		NR

NOTES:

J - Estimate; QA/QC parameter(s) outside acceptable limits; semi-quantitative.

Q - Data below contract required quantitation limits, qualitative only.

U - Data below instrument detection limits.

R - Data unusable, requirements for one or more of the inorganic procedures specified in the CLP Functional Guidelines not met.

NR - Not Required

(GWINOR2.WK1)

06/01/91

INORGANIC PARAMETER FIELD BLANKS
for GROUND WATER
CARDINGTON ROAD LANDFILL SITE
MORaine, OHIO

PARAMETERS	CAS NO.	SAMPLE LOCATIONS					
		SECOND QUARTER					
		MW-2IR		MW-3IR			
		GW02IR-02		GW02IR-02		GW03IR-02	
		05-09-90		05-22-90		05-08-89	
		Total	Dissolved	Total	Dissolved	Total	Dissolved
INORGANIC ANALYTES (ug/l)							
Aluminum	7429-90-5	36.4 Q			23.3 Q	36.4 Q	
Antimony	7440-36-0						
Arsenic	7429-38-2						
Barium	7440-39-3						
Beryllium	7440-41-7					1.0 Q	
Cadmium	7440-43-9	7.5					
Calcium	7440-70-2	148 Q	58.9 Q		455 Q	31.8 Q	32.1 Q
Chromium	7440-47-3						
Cobalt	7440-48-4						
Copper	7440-50-8	8.7 Q			11.7 Q	79	113
Iron	7439-89-6	18.8 Q	11.3 Q	25.4 Q	25.9 Q	10.3 Q	6 Q
Lead	7439-92-1	2.6 Q					
Magnesium	7439-95-4						
Manganese	7439-96-5						14.2 Q
Nickel	7440-02-0						
Potassium	7440-09-7						
Selenium	7782-49-2	R				R	
Silver	7440-22-4						
Sodium	7440-23-5						
Vanadium	7440-62-2						
Zinc	7440-66-6	23.4			47.2	26.9	
Cyanide			NR		NR		NR

NOTES:

- J - Estimate; QA/QC parameter(s) outside acceptable limits; semi-quantitative.
- Q - Data below contract required quantitation limits, qualitative only.
- U - Data below instrument detection limits.
- R - Data unusable, requirements for one or more of the inorganic procedures specified in the Functional Guidelines not met.
- NR - Not Required

(GWINOR3.WK1)
06/01/91

INORGANIC PARAMETER FIELD BLANKS
for GROUND WATER
CARDINGTON ROAD LANDFILL SITE
MORaine, OHIO

PARAMETERS	CAS NO.	SAMPLE LOCATIONS							
		MW-1I THIRD QUARTER GW01IR-03 08/90		MW-5A THIRD QUARTER GW05AR-03 08/90		MW-6A THIRD QUARTER GW06AR-03 08/90		MW-8I THIRD QUARTER GW08IR-03 08/90	
		Total	Dissolved	Total	Dissolved	Total	Dissolved	Total	Dissolved
INORGANIC ANALYTES (ug/l)									
Aluminum	7429-90-5		81.8 Q				89.4 Q		97.7 Q
Antimony	7440-36-0								
Arsenic	7429-38-2								
Barium	7440-39-3	2.3 Q	2.0 Q						3.3 Q
Beryllium	7440-41-7								
Cadmium	7440-43-9								
Calcium	7440-70-2	11,100	9,740	241 Q		393 Q	327 Q	170 Q	1,510 Q
Chromium	7440-47-3								
Cobalt	7440-48-4								
Copper	7440-50-8					4.4 Q			
Iron	7439-89-6						6.4 Q		12.0 Q
Lead	7439-92-1								
Magnesium	7439-95-4	86.5 Q							505 Q
Manganese	7439-96-5	2.6 Q		3.9 Q					5.7 Q
Mercury	7439-97-6								
Nickel	7440-02-0								
Potassium	7440-09-7				6,210				
Selenium	7782-49-2								
Silver	7440-22-4								
Sodium	7440-23-5		1,270		335 Q		660 Q		1,100 Q
Thallium	7440-28-0								
Vanadium	7440-62-2								
Zinc	7440-66-6	4.1 Q		4.2 Q		4.2 Q		5.2 Q	74.3
Cyanide			NR		NR		NR		NR

NOTES:

- J - Estimate; QA/QC parameter(s) outside acceptable limits; semi-quantitative. (GWINOR1.WK1)
- Q - Data below contract required quantitation limits, qualitative only. 06/01/91
- R - Data unusable, requirements for one or more of the inorganic procedures specified in the CLP Functional Guidelines not
- NR - Not required.

INORGANIC PARAMETER FIELD BLANKS
for GROUND WATER
CARDINGTON ROAD LANDFILL SITE
MORaine, OHIO

PARAMETERS	CAS NO.	SAMPLE LOCATIONS					
		GW02IR-04		GW06AR-04		GW08MR-04	
		Total	Dissolved	Total	Dissolved	Total	Dissolved
INORGANIC ANALYTES (ug/l)							
Aluminum	7429-90-5		66.2 Q		66.4 Q		
Antimony	7440-36-0						
Arsenic	7429-38-2	R		R	3.3 Q		
Barium	7440-39-3					1.3 Q	
Beryllium	7440-41-7						
Cadmium	7440-43-9						
Calcium	7440-70-2			880 Q			71.4 Q
Chromium	7440-47-3						
Cobalt	7440-48-4						
Copper	7440-50-8						
Iron	7439-89-6				18.1 Q		
Lead	7439-92-1						
Magnesium	7439-95-4			285 Q			
Manganese	7439-96-5						
Mercury	7439-97-6						
Nickel	7440-02-0						
Potassium	7440-09-7						
Selenium	7782-49-2	R		R			
Silver	7440-22-4						
Sodium	7440-23-5	419 Q	696 Q	1,070 Q	671 Q		637 Q
Thallium		R		R			
Vanadium	7440-62-2						
Zinc	7440-66-6						
Cyanide			NR		NR		NR

NOTES:

- J - Estimate; QA/QC parameter(s) outside acceptable limits; semi-quantitative.
- Q - Data below contract required quantitation limits, qualitative only.
- R - Data unusable, requirements for one or more of the inorganic procedures specified in the CLP Functional Guidelines not met.
- * - Intrusive boring samples were analyzed for total not the dissolved fraction of the TAL metals parameters.

(4GWINOR/1.WK1)

06/01/91

NR - Not Required

ORGANIC PARAMETER TRIP BLANKS
for GROUND WATER
CARDINGTON ROAD LANDFILL SITE
MORaine, OHIO

PARAMETERS	CAS NO.	SAMPLE LOCATIONS						
		FIRST QUARTER				SECOND QUARTER		
		GW07IT-01 12-12-89	GW05RT-01 12-13-89	GW06AT-01 12-13-89	GW03IT-01 12-14-89	GW03RT-01 12-21-89	GW03IT-02 05-08-90	GW02IT-02 05-09-90
VOLATILE ORGANIC COMPOUNDS (ug/l)			ND	ND	ND	ND		ND
Methylene Chloride	75-09-2	2 Q					30	
Acetone	67-64-1							
Carbon Disulfide	75-15-0							
Chloroform	67-66-3							
1,1-Dichloroethane	75-34-3							
1,2-Dichloroethene (total)	540-59-0							
1,1,1-Trichloroethane	71-55-6							
Tetrachloroethene	127-18-4							
Benzene	71-43-2							
Toluene	108-88-3							

NOTES:

Q - Below contract required detection limits, qualitative only.
Trip blanks analyzed for volatile organic compounds only.
ND - Not Detected

(GWORG4.WK1)
06/01/91

ORGANIC PARAMETER FIELD BLANKS
for GROUND WATER
CARDINGTON ROAD LANDFILL SITE
MORaine, OHIO

PARAMETERS	CAS NO.	SAMPLE LOCATIONS					
		FIRST QUARTER			SECOND QUARTER		
		GW071R-01 12-12-89	GW021R-01 12-13-89	GW01RR-01 12-17-89	GW041R-01 12-14-89	GW021R-02 05-09-90	GW031R-02 05-08-90
VOLATILE ORGANIC COMPOUNDS (ug/l)		ND		ND	ND		
Methylene Chloride	75-09-2						
Acetone	67-64-1				5 Q		
Carbon Disulfide	75-15-0						
Chloroform	67-66-3						2 Q
1,1-Dichloroethane	75-34-3						
1,2-Dichloroethene (total)	540-59-0						
1,1,1-Trichloroethane	71-55-6						
Tetrachloroethene	127-18-4		2 Q		1 Q		3 Q
Benzene	71-43-2						2 Q
Toluene	108-88-3						1 Q
EXTRACTABLE ORGANIC COMPOUNDS (ug/l)		ND	ND	ND	ND	ND	
Di-n-Butylphthalate	84-74-2						
Phenanthrene	85-01-8						
Fluroanthene	06-44-0						
Pyrene	129-00-0						
Benzo(a)anthracene	56-55-3						
Chrysene	218-01-9						
Bis(2-ethylhexyl)phthalate	117-81-7						3 Q
Benzo(b)fluoranthene	205-99-2						
Benzo(k)fluoranthene	07-08-9						
Benzo(a)pyrene	50-32-8						
Benzoic Acid	65-86-0						
PESTICIDES/PCBs (ug/l)*		ND	ND	ND	ND	ND	ND

NOTES:

- J - Estimate, QA/QC parameter(s) outside acceptable limits; semi-quantitative.
- Q - Data below contract required quantitation limits, qualitative only.
- ND - Not Detected

(GWORG3.WK1)
06/01/91

INDICATOR PARAMETER FIELD BLANKS
for GROUND WATER
CARDINGTON ROAD LANDFILL SITE
MORaine, OHIO

PARAMETERS	SAMPLE LOCATIONS					
	FIRST QUARTER					
	MW-2IR		MW-4IR		MW-7IR	
	GW02IR-01	GW02IR-01	GW04IR-01	GW04IR-01	GW07IR-01	GW07IR-01
	12-13-89		12-14-89		12-12-89	
	(P/I)		(P/I)		(P/I)	
INDICATOR PARAMETERS (mg/l)						
Ammonia	<1	<1	<1	<1	<1	
Chloride	<3	<3	<3	<3	<3	
Fluoride	0.013	0.014	0.014	0.014	0.000028	
Hexavalent Chromium	<0.05	<0.05	<0.05	<0.05	<0.05	
Nitrate	<1	<1	<1	<1	<0.001	
Sulfate	1.0	<1	<1	<1	1.2	

NOTES:

(P/I) - Preserved/Iced

(INDPAR5/1.WK1)

06/01/91

INDICATOR PARAMETER FIELD BLANKS
for GROUND WATER
CARDINGTON ROAD LANDFILL SITE
MORaine, OHIO

PARAMETERS	SECOND QUARTER					
	MW-2IR				MW-3IR	
	GW02IR-02	GW02IR-02	GW02IR-02	GW02IR-02	GW03IR-02	GW03IR-02
	05-09-90	(P/I)	(P/I)	05-22-90	(P/I)	05-08-90
INDICATOR PARAMETERS (mg/l)						
Ammonia	<1				<1	<1
Chloride	<3				<3	<3
Fluoride	<0.05				<0.05	<0.05
Hexavalent Chromium	<0.01				<0.05	<0.05
Nitrate					<1	<1
Sulfate	<1				5.1	<1

NOTES:

(P/I) - Preserved/Iced

(INDPAR5/2.WK1)

06/01/91

INDICATOR PARAMETER FIELD BLANKS
for GROUND WATER
CARDINGTON ROAD LANDFILL SITE
MORaine, OHIO

PARAMETERS	THIRD QUARTER							
	MW-11R		MW-5AR		MW-06AR		MW-08IR	
	GW011R-03	GW011R-03	GW05AR-03	GW05AR-03	GW06AR-03	GW06AR-03	GW08IR-03	GW08IR-03
	(P/I)		(P/I)		(P/I)		(P/I)	
INDICATOR PARAMETERS (mg/l)								
Ammonia	<0.5	<0.5	<0.5	<0.5	<0.5	<0.5	0.7	<0.5
Chloride	9.9	19	9.7	4.9	<3	<3	19	19
Fluoride	<0.05	<0.05	<0.05	<0.05	0.062	<0.05	<0.05	<0.05
Hexavalent Chromium	<0.025	<0.025	<0.025	<0.025	<0.025	<0.025	<0.026	<0.025
Nitrate	<1	<1	1.7	<1	<1	<1	<1	<1
Sulfate	<1	<1	<1	<1	<1	<1	<1	<1

NOTES:

(P/I) - Preserved/Iced

(INDPAR5/3.WK1)

06/01/91

ORGANIC PARAMETER TRIP BLANK/FIELD BLANKS
for GROUND WATER
CARDINGTON ROAD LANDFILL SITE
MORaine, OHIO

PARAMETERS	CAS NO.	SAMPLE LOCATIONS			
		GW06AR-03	GW01IR-03	GW06AT-03	GW03IT-03
VOLATILE ORGANIC COMPOUNDS (ug/l)					ND
Methylene Chloride	75-09-2	3 Q		5	
Chloroform	67-66-3	18	27		
Bromodichloromethane	75-27-4	2 Q	2 Q		
EXTRACTABLE ORGANIC COMPOUNDS (ug/l)		ND	ND	NA	NA
PESTICIDES/PCBs (ug/l)*		NA	NA	NA	NA

NOTES:

- J - Estimate; QA/QC parameter(s) outside acceptable limits; semi-quantitative.
- Q - Data below contract required quantitation limits qualitative only.
- NA - Not analyzed
- ND - No detections

(TAB1.WK1)
06/01/91

ORGANIC PARAMETER TRIP BLANK/FIELD BLANKS
for GROUND WATER
CARDINGTON ROAD LANDFILL SITE
MORAINÉ, OHIO

PARAMETERS	CAS NO.	SAMPLE LOCATIONS				
		GW05AR-03	GW05AR-03RE	GW05RT-03	GW07IT-03	GW08IR-03
VOLATILE ORGANIC COMPOUNDS (ug/l)				ND	ND	
Carbon Disulfide	75-15-0	140	47			40
Chloroform	67-66-3	56	54			51
Bromodichloromethane	75-27-4	8	7			7
Dibromochloromethane	124-48-1	1 Q	1 Q			
Toluene	108-88-3					6 J
Ethylbenzene	100-41-4					1 Q
Total Xylenes	1330-20-7					6 J
EXTRACTABLE ORGANIC COMPOUNDS (ug/l)		ND	NA	NA	NA	ND
PESTICIDES/PCBs (ug/l)*		ND	NA	NA	NA	ND

NOTES:

J - Estimate; QA/QC parameter(s) outside acceptable limits; semi-quantitative.

Q - Data below contract required quantitation limits qualitative only.

NA - Not analyzed

ND - No detections

(TAB2.WK1)

06/01/91

**ORGANIC PARAMETER TRIP BLANK/FIELD BLANKS
for GROUND WATER
CARDINGTON ROAD LANDFILL SITE
MORAIN, OHIO**

PARAMETERS	SAMPLE LOCATIONS			
	GW02IR-04	GW03RT-04	GW07IT-04	GW08MR-04
VOLATILE ORGANIC COMPOUNDS (ug/l)		ND		
Acetone			5 Q	230 J
Methylene Chloride				
Toluene	1 Q			6
Total Xylenes	1 Q			4 Q
EXTRACTABLE ORGANIC COMPOUNDS (ug/l)	NA	NA	NA	NA
PESTICIDES/PCBs (ug/l)*	NA	NA	NA	NA

NOTES:

- J - Estimate; QA/QC parameter(s) outside acceptable limits; semi-quantitative.
- Q - Data below contract required quantitation limits qualitative only.
- NA - Not analyzed
- ND - No detections

(4TAB5.WK1)
06/01/91

INDICATOR PARAMETER FIELD BLANKS
for GROUND WATER
CARDINGTON ROAD LANDFILL SITE
MORaine, OHIO

<u>PARAMETERS</u>	<u>SAMPLE LOCATIONS</u>		
	GW02IR-04	GW06AR-04	GW08MR-04
INDICATOR PARAMETERS (mg/l)			
Ammonia	<0.50	<0.56	<0.5
Chloride	<3.0	<3.0	20
Fluoride	<0.050	0.22	<0.05
Hexavalent Chromium	<0.025*	<0.025	<0.025*
Nitrate	<1.0	<1.0*	<1
Sulfate	<5.0	<5.0	<5.0

NOTES:

* - Hold time for Hexavalent Chromium and Nitrate-N analyses was exceeded upon receipt of samples.
(P/I) - Preserved/Iced

(FBGWLSB/2.WK1)
06/01/91

ORGANIC PARAMETER MATRIX SPIKES/MATRIX SPIKE DUPLICATES
FOR INTRUSIVE BORINGS AND GROUND WATER
CARDINGTON ROAD LANDFILL SITE
MORaine, OHIO

SAMPLE LOCATIONS

PARAMETERS	MATRIX SPIKE IB02S-01	MATRIX SPIKE DUPLICATE IB02S-01	MATRIX SPIKE GW05IS-04	MATRIX SPIKE DUPLICATE GW05IS-04
VOLATILE ORGANIC COMPOUNDS (ug/l)			ND	ND
Acetone				
1,1,1-Trichloroethane				
Carbon Disulfide				
1,1-Dichloroethane				
1,2-Dichloroethane (total)				
Methylene Chloride				
Chloroform				
Bromodichloromethane				
Ethylbenzene	7	7		
Total Xylenes	7	7		
EXTRACTABLE ORGANIC COMPOUNDS (ug/l)	R	R	NA	NA
2-Nitrophenol				
Bis(2-ethylhexyl)phthalate	320 J	240		
Benzyl Alcohol	3 Q	2 Q		
Naphthalene	68	65		
2-Methylnaphthalene	8 Q	7 Q		
Dibenzofuran	9 Q	7 Q		
Fluorene	13	10		
Phenanthrene	48	36		
Anthracene	11	9 Q		
Fluoranthene	44	33		
Butylbenzylphthalate	6 Q	5 Q		
Benzo(a)anthracene	20	14		
Chrysene	21	16		
Di-n-Octyl Phthalate	3 Q	3 Q		
Benzo(b)Fluoranthene	15	24		
Benzo(k)Fluoranthene	28	36		
Benzo(a)Pyrene	20	15		
PESTICIDES/PCBs (ug/l)	ND	ND	NA	NA

NOTES:

J - Estimate; QA/QC parameter(s) outside acceptable limits; semi-quantitative.

Q - Data below contract required quantitation limits qualitative only.

R - Unusable.

(4TAB8A.WK1)

06/01/91

ORGANIC PARAMETER TRIP BLANK/FIELD BLANKS
for GROUND WATER and LEACHATE
CARDINGTON ROAD LANDFILL SITE
MORaine, OHIO

PARAMETERS	SAMPLE LOCATIONS					
	GW08MR-04RE	GW06AS-04RE	GW03AT-04	GW06AR-04	IB01T-01	IB05R-01
VOLATILE ORGANIC COMPOUNDS (ug/l)						
Acetone	17 J	210				
Methylene Chloride						
1,1-Dichloroethane					10 J	
1,2-Dichloroethane (Total)					2 Q	
2-Butanone		R	R		4 Q	
Tetrachloroethene			1 Q			
Chloroform						16
Bromodichloromethane						1 Q
Toluene		8				
Total Xylenes		6 Q			R	
Vinyl Acetate						
EXTRACTABLE ORGANIC COMPOUNDS (ug/l)	NA	NA	NA	NA	NA	ND
PESTICIDES/PCBs (ug/l)*	NA	NA	NA	NA	NA	ND

NOTES:

- J - Estimate; QA/QC parameter(s) outside acceptable limits; semi-quantitative.
- Q - Data below contract required quantitation limits qualitative only.
- NA - Not analyzed
- ND - No detections

(4TAB6.WK1)
06/01/91

INORGANIC PARAMETER FIELD BLANKS
for LEACHATE
CARDINGTON ROAD LANDFILL SITE
MORaine, OHIO

PARAMETERS	CAS NO.	SAMPLE LOCATIONS						
		IB01S-01 Total*	IB02S-01 Total*	IB03S-01 Total*	IB04S-01 Total*	IB05D-01 Total*	IB05S-01 Total*	IB05R-01 Total*
INORGANIC ANALYTES (ug/l)								
Aluminum	7429-90-5	298,000 J	69,200 J	168,000	213,000 J	335,000 J	56,500 J	
Antimony	7440-36-0	33.1 Q		39.4 Q				
Arsenic	7429-38-2	620	56.4 J	170	246	407	328	R
Barium	7440-39-3	5,210	5,940	5,200	5,150	15,800	16,100	
Beryllium	7440-41-7	13.8	4.0 Q	8.2	10.5	18.5	11.2	
Cadmium	7440-43-9	41.7 J	23.5 J	20.9	65.1 J	365 J	98.2 J	
Calcium	7440-70-2	3,850,000	1,150,000	1,710,000	4,410,000	4,890,000	5,550,000	
Chromium	7440-47-3	890J	486 J	2,220	1,240 J	1,820 J	92.2 J	
Cobalt	7440-48-4	305	82.6	209	244	437	252	
Copper	7440-50-8	2,060 J	601 J	1,300	2,340 J	3,580 J		
Iron	7439-89-6	1,050,000	241,000J	415,000	651,000 J	,110,000	,110,000 J	
Lead	7439-92-1	2,710 J	1,850 J	7,280	2,710 J	6,120 J	4,400 J	
Magnesium	7439-95-4	1,370,000	463,000	690,000	1,650,000	1,780,000	1,960,000	57.5 Q
Manganese	7439-96-5	13,000	3,830	8,930	11,000	20,600	20,200	
Mercury	7439-97-6	2.1	.94	R	1.6	1.8	1.6	
Nickel	7440-02-0	1,020	394	1,060	908	1,560	835	
Potassium	7440-09-7	196,000	213,000	133,000	129,000	349,000	349,000	
Selenium	7782-49-2	R	R		R	R		R
Silver	7440-22-4							
Sodium	7440-23-5	734,000	865,000	586,000	516,000	903,000	938,000	789 Q
Thallium		R	R	363	R	R		R
Vanadium	7440-62-2	654	151	12,800	443	584	153	
Zinc	7440-66-6	11,700 J	6,090 J		13,000 J	44,400 J	43,000 J	
Cyanide		51.3 J	49.2 J		28.0 J	12.4 J	31.1 J	26.1 J

NOTES:

- J - Estimate; QA/QC parameter(s) outside acceptable limits; semi-quantitative.
- Q - Data below contract required quantitation limits, qualitative only.
- R - Data unusable, requirements for one or more of the inorganic procedures specified in the CLP Functional Guidelines not met.
- * - Intrusive boring samples were analyzed for total not the dissolved fraction of the TAL metals parameters.

(4GWINOR/2.WK1)
06/01/91

INDICATOR PARAMETER FIELD BLANKS
for LEACHATE
CARDINGTON ROAD LANDFILL SITE
MORaine, OHIO

PARAMETERS	SAMPLE LOCATIONS	
	P/I IB05R-01	IB05R-01
INDICATOR PARAMETERS (mg/l)		
Ammonia	<0.50	<0.50
Chloride	<3.0	<3.0
Fluoride	<0.050	<0.050
Hexavalent Chromium	<0.025	<0.025
Nitrate	<1.0	<1.0
Sulfate	<5.0	<5.0

NOTES:

(P/I) - Preserved/Iced

(FBGWLSB/1.WK1)

06/01/91

INDICATOR PARAMETER FIELD BLANKS
for SOIL BORINGS
CARDINGTON ROAD LANDFILL SITE
MORaine, OHIO

<u>PARAMETERS</u>	<u>SAMPLE LOCATIONS</u>
	3R225237
INDICATOR PARAMETERS (mg/kg)	
Ammonia	21
Chloride	<90
Fluoride	1.8
Hexavalent Chromium	<0.05
Nitrate	<20
Sulfate	Negative

NOTES:

(P/I) - Preserved/Iced

(FBGWLSB/3.WK1)
06/01/91

ORGANIC, INORGANIC, and INDICATOR PARAMETER
TRIP BLANKS for SOIL BORING SAMPLES
CARDINGTON ROAD LANDFILL SITE
MORANE, OHIO

PARAMETERS	CAS NO.	SAMPLE IDENTIFICATION/SAMPLE INTERVAL					
		MW-1R		MW-2R		MW-3R	
		01B176177T 176'-177'	18236237T 236'-237'	18262263T 262'-263'	28140142T 140'-142'	8803RT 226'-227'	8803RT 260'-267'
VOLATILE ORGANIC COMPOUNDS (ug/kg)		ND	ND	ND	ND	ND	ND
Acetone	67-64-1						
Chloroform	67-66-3						
1,1-Dichloroethane	75-35-3						
1,2-Dichloroethane	107-06-2						
1,2-Dichloroethane (total)	640-69-0						
Methylene Chloride	75-09-2						
Toluene	108-88-3						
1,1,1-Trichloroethane	71-55-6						
SEMI-VOLATILES (ug/kg)		NA	NA	NA	NA	NA	NA
Anthracene	120-12-7						
Benzo(a)anthracene	66-55-3						
Benzo(b)fluoranthene	205-99-2						
Benzoic Acid	65-85-0						
Benzo(k)fluoranthene	207-08-9						
Benzopyrene	60-32-8						
Bis(2-ethylhexyl)phthalate	117-81-7						
Chrysene	218-01-9						
Fluoranthene	206-44-0						
Pentachlorophenol	87-86-6						
Phenanthrene	85-01-8						
Pyrene	129-00-0						
PESTICIDES/PCBs (ug/kg)		NA	NA	NA	NA	NA	NA
INORGANIC ANALYTES (mg/kg)		NA	NA	NA	NA	NA	NA
Aluminum	7429-90-6						
Antimony	7440-36-0						
Arsenic	7429-38-2						
Barium	7440-39-3						
Beryllium	7440-41-7						
Calcium	7440-70-2						
Chromium	7440-47-3						
Cobalt	7440-48-4						
Copper	7440-50-8						
Iron	7439-89-6						
Lead	7439-92-1						
Magnesium	7439-95-4						
Manganese	7439-96-5						
Mercury	7439-97-6						
Nickel	7440-02-0						
Potassium	7440-09-7						
Selenium	7782-49-2						
Sodium	7440-23-5						
Thallium	7440-28-0						
Vanadium	7440-62-2						
Zinc	7440-66-6						
INDICATOR PARAMETERS (mg/kg)		NA	NA	NA	NA	NA	NA

NOTES:

J - Estimate; QA/QC parameter(s) outside acceptable limits, semi-quantitative
Q - Data below contract required quantitation limits

ND - No detections.
NA - Not analyzed

(SBTB/1 WK 1)
06/01/91

ORGANIC, INORGANIC, and INDICATOR PARAMETER
TRIP BLANKS for SOIL BORING SAMPLES
CARDINGTON ROAD LANDFILL SITE
MORFANE, OHIO

PARAMETERS	CAS NO.	SAMPLE IDENTIFICATION/SAMPLE INTERVAL					
		MW-6R		MW-6A		T8808A-01	8804A-0
		580002T 80'-82'	58210212T 210'-212'	58235237T 235'-237'	58280282T 280'-282'		
VOLATILE ORGANIC COMPOUNDS (ug/kg)		ND	ND			ND	2 J
Acetone	67-64-1			17 J			
Chloroform	67-68-3						
1,1-Dichloroethane	75-35-3						
1,2-Dichloroethane	107-08-2						
1,2-Dichloroethane (total)	540-58-0			8	1 Q		
Methylene Chloride	75-09-2						
Toluene	108-88-3			2 J			
1,1,1-Trichloroethane	71-66-8						
SEMI-VOLATILES (ug/kg)		NA	NA	NA	NA	NA	NA
Anthracene	120-12-7						
Benzo(a)anthracene	56-55-3						
Benzo(b)fluoranthene	205-99-2						
Benzoic Acid	65-85-0						
Benzo(k)fluoranthene	207-08-9						
Benzo(a)pyrene	50-32-8						
Bis(2-ethylhexyl)phthalate	117-81-7						
Chrysene	218-01-9						
Fluoranthene	206-44-0						
Pentachlorophenol	87-86-6						
Phenanthrene	85-01-8						
Pyrene	129-00-0						
PESTICIDES/PCBs (ug/kg)		NA	NA	NA	NA	NA	NA
INORGANIC ANALYTES (mg/kg)		NA	NA	NA	NA	NA	NA
Aluminum	7429-90-5						
Antimony	7440-36-0						
Arsenic	7429-38-2						
Barium	7440-39-3						
Beryllium	7440-41-7						
Calcium	7440-70-2						
Chromium	7440-47-3						
Cobalt	7440-48-4						
Copper	7440-50-8						
Iron	7439-89-6						
Lead	7439-92-1						
Magnesium	7439-95-4						
Manganese	7439-96-5						
Mercury	7439-97-6						
Nickel	7440-02-0						
Potassium	7440-09-7						
Selenium	7782-49-2						
Sodium	7440-23-5						
Thallium	7440-28-0						
Vanadium	7440-62-2						
Zinc	7440-66-6						
INDICATOR PARAMETERS (mg/kg)		NA	NA	NA	NA	NA	NA

NOTES:

J - Estimate; Q/VOC parameter side acceptable limits; semi-quantitative
Q - Data below contract required dilution limits

(- No detections.
- - Not analyzed

(SBTB/2 WK1)
06/01/91

ORGANIC PARAMETER MATRIX SPIKES/
MATRIX SPIKE DUPLICATES for SOIL BORINGS
CARDINGTON ROAD LANDFILL SITE
MORaine, OHIO

PARAMETERS	CAS NO.	SAMPLE LOCATIONS											
		MATRIX SPIKE SB06A-01	MATRIX SPIKE DUPLICATE SB06A-01	MATRIX SPIKE SB05A (52'-54')	MATRIX SPIKE DUPLICATE SB05A (52'-54')	MATRIX SPIKE SB01A (54'-56')	MATRIX SPIKE DUPLICATE SB01A (54'-56')	MATRIX SPIKE SB06A-01 (56'-58')	MATRIX SPIKE DUPLICATE SB06A-01 (56'-58')	MATRIX SPIKE SB05A (16'-18')	MATRIX SPIKE DUPLICATE SB05A (16'-18')	MATRIX SPIKE SB05A (18'-23')	MATRIX SPIKE DUPLICATE SB05A (18'-23')
VOLATILE ORGANIC COMPOUNDS (ug/kg)		ND	ND	ND	ND	NA	NA	NA	NA	ND	ND	NA	NA
EXTRACTABLE ORGANIC COMPOUNDS (ug/kg)		ND	ND	NA	NA	ND	ND	NA	NA	NA	NA	ND	ND
PESTICIDES/PCBs (ug/kg)		ND	ND	NA	NA	NA	NA	ND	ND	NA	NA	ND	ND

PARAMETERS	CAS NO.	SAMPLE LOCATIONS											
		MATRIX SPIKE SB03A 94'-96'	MATRIX SPIKE DUPLICATE SB03A 94'-96'	MATRIX SPIKE SB03A 100'-106'	MATRIX SPIKE DUPLICATE SB03A 100'-106'	MATRIX SPIKE SB03A 128'-138'	MATRIX SPIKE DUPLICATE SB03A 128'-138'	MATRIX SPIKE SB04A 60'-62'	MATRIX SPIKE DUPLICATE SB04A 60'-62'	MATRIX SPIKE SB04A-01	MATRIX SPIKE DUPLICATE SB04A-01	MATRIX SPIKE SB02A-01	MATRIX SPIKE DUPLICATE SB02A-01
VOLATILE ORGANIC COMPOUNDS (ug/kg)		ND	ND	NA	NA	NA	NA	ND	ND	NA	NA		
Acetone	67-64-1											28	
1,2-Dichloroethene (total)	75-09-2												9
EXTRACTABLE ORGANIC COMPOUNDS (ug/kg)		NA	NA	ND	ND	NA	NA	NA	NA	ND	ND	ND	ND
PESTICIDES/PCBs (ug/kg)		NA	NA	NA	NA	ND	ND	ND	ND	NA	NA	NA	NA

NOTES:

- J - Estimate; QA/QC parameter(s) outside acceptable limits; semi-quantitative
- Q - Data below contract required quantitation limits qualitative only
- NA - Not Analyzed
- ND - Not Detected

ORGANIC PARAMETER MATRIX SPIKES/
MATRIX SPIKE DUPLICATES for SOIL BORINGS
CARDINGTON ROAD LANDFILL SITE
MORaine, OHIO

PARAMETERS	CAS NO.	SAMPLE LOCATIONS											
		MATRIX SPIKE SB07A 142'-144'	MATRIX SPIKE DUPLICATE SB07A 142'-144'	MATRIX SPIKE SB07A 142'-152'	MATRIX SPIKE DUPLICATE SB07A 142'-152'	MATRIX SPIKE SB06B 254'-256'	MATRIX SPIKE DUPLICATE SB06B 254'-256'	MATRIX SPIKE SB06B 290'-297'	MATRIX SPIKE DUPLICATE SB06B 290'-297'	MATRIX SPIKE SB06B 290'-292'	MATRIX SPIKE DUPLICATE SB06B 290'-292'	MATRIX SPIKE SB01B 252'-253'	MATRIX SPIKE DUPLICATE SB01B 252'-253'
VOLATILE ORGANIC COMPOUNDS (ug/kg)		ND	ND	NA	NA				NA	NA	NA	ND	ND
Acetone	67-64-1					30 J	41 J					28	
1,1-Dichloroethane	75-34-0												
1,2-Dichloroethane (total)	75-09-2												9
Methylene Chloride	67-66-3					30 J	43 J						
Chloroform	75-27-4					2 Q	2 Q						
Bromodichloromethane	75-27-1												
EXTRACTABLE ORGANIC COMPOUNDS (ug/kg)		NA	NA			NA	NA		ND	NA	NA		
Fluoranthene	206-44-0			450	710								
Phenanthrene	85-01-8				560								
Benzoic Acid	65-85-0							87 Q					
Bis(2-ethylhexyl)phthalate	117-81-7							46 Q					
PESTICIDES/PCBs (ug/kg)		NA	NA	ND	ND	NA	NA	NA	NA	ND	ND		

NOTES:

J - Estimate; QA/QC parameter(s) outside acceptable limits; semi-quantitative

Q - Data below contract required quantitation limits qualitative only

NA - Not Analyzed

ND - Not Detected

(MSMSD5B/2.WK1)

08/03/91

ORGANIC PARAMETER MATRIX SPIKES/
MATRIX SPIKE DUPLICATES for SOIL BORINGS
CARDINGTON ROAD LANDFILL SITE
MORaine, OHIO

PARAMETERS	CAS NO.	SAMPLE LOCATIONS					
		MATRIX SPIKE	MATRIX SPIKE DUPLICATE	MATRIX SPIKE	MATRIX SPIKE DUPLICATE	MATRIX SPIKE	MATRIX SPIKE DUPLICATE
		1B	1B	3R	3R	3R	3R
		240'-242'	240'-242'	225'-227'	225'-227'	235'-242'	235'-242'
VOLATILE ORGANIC COMPOUNDS (ug/kg)		NA	NA	ND	ND	NA	NA
EXTRACTABLE ORGANIC COMPOUNDS (ug/kg)		ND	ND	NA	NA	ND	ND
PESTICIDES/PCBs (ug/kg)		ND	ND	NA	NA	ND	ND

NOTES:

- J - Estimate; QA/QC parameter(s) outside acceptable limits; semi-quantitative
- Q - Data below contract required quantitation limits qualitative only
- NA - Not Analyzed
- ND - Not Detected

(MSMSOSB/5.WK1)
06/03/91

ORGANIC, INORGANIC, and INDICATOR PARAMETER
TRIP BLANKS for DRINKING WATER
CARDINGTON ROAD LANDFILL SITE
MORANE, OHIO

PARAMETERS	CAS NO.	SAMPLE IDENTIFICATION/ SAMPLE INTERVAL		
		TDW01-01	TDW01-02	DW112189T 112-189'
VOLATILE ORGANIC COMPOUNDS (ug/kg)		ND	ND	ND
Acetone	67-64-1			
Chloroform	67-66-3			
1,1-Dichloroethane	75-35-3			
1,2-Dichloroethane	107-06-2			
1,2-Dichloroethane (total)	640-50-0			
Methylene Chloride	75-09-2			
Toluene	108-88-3			
1,1,1-Trichloroethane	71-55-8			
SEMI-VOLATILES (ug/kg)		NA	NA	
Anthracene	120-12-7			
Benzo(a)anthracene	56-56-3			
Benzo(b)fluoranthene	206-90-2			
Benzoic Acid	65-85-0			
Benzo(k)fluoranthene	207-08-9			
Benzo(a)pyrene	50-32-8			
Bis(2-ethylhexyl)phthalate	117-81-7			
Chrysene	218-01-9			
Fluoranthene	206-44-0			
Pentachlorophenol	87-86-5			
Phenanthrene	85-01-8			
Pyrene	129-00-0			
PESTICIDES/PCBs (ug/kg)		NA	NA	
INORGANIC ANALYTES (mg/kg)		NA	NA	
Aluminum	7429-90-6			
Antimony	7440-36-0			
Arsenic	7429-38-2			
Barium	7440-39-3			
Beryllium	7440-41-7			
Calcium	7440-70-2			
Chromium	7440-47-3			
Cobalt	7440-48-4			
Copper	7440-50-8			
Iron	7439-89-6			
Lead	7439-92-1			
Magnesium	7439-96-4			
Manganese	7439-96-5			
Mercury	7439-97-8			
Nickel	7440-02-0			
Potassium	7440-06-7			
Selenium	7782-49-2			
Sodium	7440-23-5			
Thallium	7440-28-0			
Vanadium	7440-62-2			
Zinc	7440-66-6			
INDICATOR PARAMETERS (mg/kg)		NA	NA	

NOTES:

J - Estimate; QA/QC parameter(s) outside acceptable limits; semi-quantitative
Q - Data below contract required detection limits

ND - No detections.
NA - Not analyzed

(SBTB/3.WK1)
06/01/91

ORGANIC PARAMETER MATRIX SPIKES/
MATRIX SPIKE DUPLICATES for DRINKING WATER
CARDINGTON ROAD LANDFILL SITE
MORaine, OHIO

PARAMETERS	CAS NO.	SAMPLE LOCATIONS											
		MATRIX SPIKE DW01-01	MATRIX SPIKE DUPLICATE DW01-01	MATRIX SPIKE DW01-02	MATRIX SPIKE DUPLICATE DW01-02	MATRIX SPIKE DW10-3-89	MATRIX SPIKE DUPLICATE DW10-3-89	MATRIX SPIKE DW10-26-89	MATRIX SPIKE DUPLICATE DW10-26-89	MATRIX SPIKE DW11-21-89	MATRIX SPIKE DUPLICATE DW11-21-89	MATRIX SPIKE DC 0790	MATRIX SPIKE DUPLICATE DC 0790
VOLATILE ORGANIC COMPOUNDS (ug/kg)												ND	ND
Chloroform	75-27-4	7	7	11	10	7	6			4 Q	4 Q		
Bromodichloromethane	75-27-1	8	7	8	7	6	6	5	5	4 Q	3 Q		
Dibromochloromethane	124-48-1	7	6	6	6	6	6		5	4 Q	3 Q		
EXTRACTABLE ORGANIC COMPOUNDS (ug/kg)												ND	ND
PESTICIDES/PCBs (ug/kg)												ND	ND

NOTES:

- J - Estimate; QA/QC parameter(s) outside acceptable limits; semi-quantitative
- Q - Data below contract required quantitation limits qualitative only
- NA - Not Analyzed
- ND - Not Detected

(MSMSDSB/4.WK1)
06/03/91

TRIP BLANK and FIELD BLANKS
for SURFACE WATER SAMPLES
CARDINGTON ROAD LANDFILL SITE
MORAIN, OHIO

PARAMETERS	CAS NO.	TRIP BLANK		FIELD BLANK								
		SPW01T-01	SW010T-01	SW002T-01	SW002DT-01	SWR	SPW-T	SW003T-01	SW006T-01	SW008TB-01	SW009TB-01	SW010TB-01
		06-29-89	06-30-89			06-30-89	11-30-89					
VOLATILE ORGANIC COMPOUNDS (ug/l)		ND		ND	ND			ND	ND	ND	ND	
Methylene Chloride	75-09-2		2 J									2 J
Acetone	67-64-1							10				
1,1-Dichloroethane	75-35-3											
1,2-Dichloroethane (total)	540-59-0											
EXTRACTABLE ORGANIC COMPOUNDS (ug/l)*		NA	NA					NA				
PESTICIDES/PCBs (ug/l)*		NA	NA					NA				
INORGANIC ANALYTES (ug/l)		NA	NA					NA				
Aluminum	7429-90-5											
Antimony	7440-36-0											
Arsenic	7429-38-2											
Barium	7440-39-3											
Beryllium	7440-41-7											
Cadmium	7440-43-9											
Calcium	7440-70-2											
Chromium	7440-47-3											
Cobalt	7440-48-4											
Copper	7440-50-8											
Iron	7439-89-6											
Lead	7439-92-1							1.1 J				
Magnesium	7439-95-4											
Manganese	7439-96-5							4.3 Q				
Mercury	7439-97-6											
Nickel	7440-02-0											
Potassium	7440-09-7											
Silver	7440-22-4											
Sodium	7440-23-5											
Vanadium	7440-62-2											
Zinc	7440-66-8							4.0 J				

NOTES:

J - Estimate. QA/QC parameter(s) outside acceptable limits; semi-quantitative

Q - Data below contract required quantitation limits, qualitative only

NA - Analysis not applicable

ND - Not Detected

(TRIPW.WK1)

06/01/91

ORGANIC PARAMETER MATRIX SPIKES/MATRIX SPIKE DUPLICATES
FOR GROUND WATER AND PRODUCTION WELLS
CARDINGTON ROAD LANDFILL SITE
MORAIN, OHIO

SAMPLE LOCATIONS

PARAMETERS	CAS NO.	MATRIX SPIKE	MATRIX SPIKE DUPLICATE	MATRIX SPIKE	MATRIX SPIKE DUPLICATE	MATRIX SPIKE	MATRIX SPIKE DUPLICATE	MATRIX SPIKE	MATRIX SPIKE DUPLICATE	MATRIX SPIKE	MATRIX SPIKE DUPLICATE	MATRIX SPIKE	MATRIX SPIKE DUPLICATE
		GW01IS-03	GW01IS-03	GW01RS-03	GW01RS-03	GW01RD-03	GW01RD-03	PW02S-01	PW02S-01	GW06AR-03	GW06AR-03	GW06IR-03	GW06IR-03
VOLATILE ORGANIC CMPDS (ug/l)													
1,1,1-Trichloroethane	71-55-8	4 Q	3 Q			NA	NA					NA	NA
Carbon Disulfide	75-15-0												
1,1-Dichloroethane	75-34-0												
1,2-Dichloroethene (total)	40-50-0							4	3				
Methylene Chloride	75-09-2									4 Q	4 Q		
Chloroform	67-68-3									16	17		
Bromodichloromethane	75-27-4									2 Q	2 Q		
EXTRACTABLE ORGANIC CMPDS (ug/l)													
2-Nitrophenol	88-75-5	NA	NA	ND	ND	3 Q	2 Q		ND	ND	ND	NA	NA
Bis(2-ethylhexyl)phthalate	17-81-7						3 Q	1					
PESTICIDES/PCBs (ug/l)*		NA	NA	NA	NA	NA	NA	NA	NA	NA	NA	ND	ND

NOTES:

J - Estimate; QA/QC parameter(s) outside acceptable limits; semi-quantitative
Q - Data below contract required quantitation limits qualitative only

NA - Not analyzed
ND - No detections

(TAB7.WK1)
06/01/91

TRIP BLANKS AND FIELD BLANKS FOR
PERIMETER AIR MONITORING STATIONS
CARDINGTON ROAD LANDFILL SITE
MORaine, OHIO

<u>PARAMETERS</u>	<u>CAS NO.</u>	<u>SAMPLE LOCATIONS</u>		
		TRIP BLANKS ROUND 1 07-25-89	TRIP BLANKS AA001T-02 12-15-89	FIELD BLANK AA001R-02 12-15-89
VOLATILE ORGANIC COMPOUNDS (ppbv)		ND		
Dichlorodifluoromethane	75-71-8			
Chloromethane	74-87-3			
1,2-Dichloro-1,1,2,2-Tetrafluoroethane	76-14-2			
Trichlorofluoromethane	75-69-4		2800	270
1,1,2-Trichloro-1,2,2-Trifluoroethane	76-13-1			
Acetone	67-64-1			
Methylene Chloride	75-09-2			
2-Butanone	78-93-3			
1,1,1-Trichloroethane	71-55-6			
4-Methyl-2-Pentanone	109-10-1			
Toluene	108-88-3		3800	3.6
2-Hexanone	591-78-6			
Ethylbenzene	100-41-4			
1,4- and 1,3 (p,m) Xylene	1330-20-7			
METHANE (ppm) (vol/vol)		ND	4.9	ND

NOTES:

NA - Not Analyzed.

ND - Not Detected.

(PERAIR4A.WK1)

06/01/91

TRIP BLANKS for OFF-SITE SOIL GAS PROBE SAMPLES
CARDINGTON ROAD LANDFILL SITE
MORaine, OHIO

SAMPLE LOCATION

PARAMETER	CAS NO.	AA-09-07-89	SGR	SGT
VOLATILE ORGANIC COMPOUNDS (ppbv)				ND
Chloromethane				
Chloroform				
Dichlorodifluoromethane	75-71-8			
1,2-Dichloro-1,1,2,2-Tetrafluoroethane	76-14-2			
Vinyl Chloride	75-01-4			
Bromomethane	74-83-9			
Chloroethane	75-00-3			
Trichlorofluoromethane	75-69-4	6.9		
1,1,2-Trichloro-1,2,2-Trifluoroethane				
Acetone	67-64-1			
Hexane	110-54-3			
1,1-Dichloroethane	75-34-3			
Vinyl Acetate	108-05-4			
trans-1,2-Dichloroethene				
1,1-Dichloroethene	75-35-44			
1,1,1-Trichloroethane	71-55-6	2.7		
Benzene	71-43-2			
Trichloroethene	79-00-5			
4-Methyl-2-pentanone				
Toluene	108-88-3			
Tetrachloroethene	127-18-4			
2-Hexanone	491-78-6			
2-Butanone				
Chlorobenzene	108-90-7			
Ethylbenzene	100-41-4			
1,4-and 1,3-(p,m)xylene	1330-20-7		3.7	
1,2-(o)xylene	1330-20-7		11	
Benzyl Chloride	100-44-7		4.4	
4-Ethyl Toluene			10	
1,3,5-Trimethylbenzene	108-67-8			
1,2,4-Trimethylbenzene	95-63-6			
Methane (in %)(vol/vol)		9 *	2.4 *	ND

NOTES:

Samples collected on September 7, 1989.

* - Results given in ppm (v/v).

(OFFGAS2A.WK1)

08/03/91

FIELD BLANKS for
GAS VENT LIQUID SAMPLES
CARDINGTON ROAD LANDFILL SITE
MORAIN, OHIO

PARAMETERS	CAS NO.	FIELD BLANK WLR-01
VOLATILE ORGANIC COMPOUNDS (ug/l)(a)		ND
Methylene Chloride	75-09-2	
Xylenes (total)	1330-20-7	
EXTRACTABLE ORGANIC COMPOUNDS (ug/l)(a)		ND
INORGANIC ANALYTES (ug/l)		
Aluminum	7429-90-5	43.2 Q
Arsenic	7429-38-2	
Barium	7440-39-3	
Calcium	7440-70-2	849 Q
Chromium	7440-47-3	
Cobalt	7440-48-4	7.4 Q
Copper	7440-50-8	
Iron	7439-89-6	72.6 Q
Lead	7439-92-1	0.97 J
Magnesium	7439-95-4	
Manganese	7439-96-5	
Mercury	7439-97-6	
Nickel	7440-02-0	
Potassium	7440-09-7	
Selenium	7782-49-2	
Silver	7440-22-4	
Sodium	7440-23-5	3,850 Q
Thallium	7440-28-0	
Vanadium	7440-62-2	15.5 Q
Zinc	7440-66-6	8.6 J

NOTES:

J - Estimate; QA/QC parameter(s) outside acceptable limits; semi-quantitative.
Q - Data below contract required quantitation limits, qualitative only.
ND - Not Detected

(VENTLW2 WK1)
06/01/91

**SUMMARY of INDICATOR PARAMETER
RESULTS for DRILLING WATER
CARDINGTON ROAD LANDFILL SITE
MORaine, OHIO**

PARAMETERS	SAMPLE LOCATIONS						
	DW01-02 8/89	DW090789 9/89 (P/I)	DW10-3-89 10/89 (P/I)	DW112189 11/89 (P/I)			
INDICATOR PARAMETERS (ug/l)							
Ammonia	1.0	71	<1.0	<1.0*	<1.0	<1.0	
Chloride	<1.0	41	38	39	37*	34	34
Fluoride	77	1.0	1.0	0.89	0.90*	1.0	1.0
Hexavalent Chromium	6.05	<0.02	<0.02	0.05	<0.05	<0.05	0.05
Nitrate	<1.0	1.0	<1.0	1.1*	1.3	<1.0	<1.0
Sulfate	37	71	71	68	60*	49	65

NOTES:

(P/I) - Preserved and iced
* Iced only

(DWIP.WK1)
06/01/91

SUMMARY of DETECTED INORGANIC
ANALYTES for DRILLING WATER
CARDINGTON ROAD LANDFILL SITE
MORaine, OHIO

PARAMETERS	CAS NO.	SAMPLE LOCATIONS						
		DW01-01 7/89	DW01-02 8/89	DW090789 9/89	DW10-3-89 10/89	DW102689A 10/89	DW102689B 10/89	DW112189 11/89
INORGANIC ANALYTES (ug/l)								
Aluminum	7429-90-5				27.6Q			72.2Q
Antimony	7440-36-0							
Arsenic	7429-38-2						3.2Q	
Barium	7440-39-3	84.5Q	66.4Q	68.7Q	61.8Q	71.9Q	71.9Q	57.4Q
Beryllium	7440-41-7			3.8Q		2.1Q		
Cadmium	7440-43-9					27.4J	15.9J	
Calcium	7440-70-2	29,300	22,900	21,300	21,100J	28,700	29,500	21,000
Chromium	7440-47-3					23.8	13.7Q	
Cobalt	7440-48-4					14.3Q	5.7Q	5.1Q
Copper	7440-50-8	12.2Q			23,800J			14Q
Iron	7439-89-6	37.3Q			77.4Q	128	44.6Q	100
Lead	7439-92-1	19.4J						
Magnesium	7439-95-4	32,200	24,700	23,200		31,000	31,800	30,700J
Manganese	7439-96-5	7.6Q	6.3Q	4.6Q		11.7Q		17.2
Mercury	7439-97-6							
Nickel	7440-02-0							
Potassium	7440-09-7	2,310Q				5,310	1,230Q	2,130Q
Selenium	7782-49-2	1.6Q						
Silver	7440-22-4							
Sodium	7440-23-5	19,600	21,200	18,400	19,700J	20,100	20,000	18,100
Thallium	7440-28-0							
Vanadium	7440-62-2	2.5Q						
Zinc	7440-66-6	10.9Q			38.3J	93.9J	81.4J	34.9J
Cyanide								

NOTES:

J - Estimate; QA/QC parameter(s) outside acceptable limits; semi-quantitative.
 Q - Data below contract required quantity limits, qualitative only.
 Data presented for total metals.

(DWINOR.WK1)
 06/01/91

**SUMMARY of DETECTED ORGANIC CONSTITUENTS
for DRILLING WATER
CARDINGTON ROAD LANDFILL SITE
MORaine, OHIO**

PARAMETERS	SAMPLE LOCATIONS					
	DW01-01 7/89	TDW01-01 7/89	DW01-01MS 7/89	DW01-01MSD 7/89	DW01-02 8/89	TDW01-02 8/89
VOLATILE ORGANIC COMPOUNDS (ug/l)		ND				
Bromoform					2Q	ND
4-methyl-3-pentanone						
Chloroform	7		7	7	10	
Bromodichloromethane	7		8	7		
Dibromochloromethane	7		7	6	7	
EXTRACTABLE ORGANIC COMPOUNDS (ug/l)	ND	NA	ND	ND	ND	NA
Pentachlorophenol						
PESTICIDES/PCBs (ug/l)	ND	NA	ND	ND	ND	NA

PARAMETERS	SAMPLE LOCATIONS				
	DW01-02MS 8/89	DW01-02MSD 8/89	DW10-3-89 10/89	DW10-3-89MS 10/89	DW10-3-89 10/89
VOLATILE ORGANIC COMPOUNDS (ug/l)					
Bromoform	2J	2J	2J	2J	2J
4-methyl-3-pentanone		3J			
Chloroform	11	10	7	7	6
Bromodichloromethane	8	7	6	6	6
Dibromochloromethane	6	6	7	6	6
EXTRACTABLE ORGANIC COMPOUNDS (ug/l)	ND	ND		ND	ND
Pentachlorophenol			18J		
PESTICIDES/PCBs (ug/l)	ND	ND	ND	ND	ND

NOTES:

J - Estimate; QA/QC parameter(s) outside acceptable limits; semi-quantative
Q - Data below contract required quantitation limits qualitative only

NA - Not analyzed
ND - No detections

(DWORG/1.WK1)
06/01/91

SUMMARY of DETECTED ORGANIC CONSTITUENTS
for DRILLING WATER
CARDINGTON ROAD LANDFILL SITE
MORaine, OHIO

PARAMETERS	SAMPLE LOCATIONS					
	DW102689A 10/89	DW102689B 10/89	DW102689BMS 10/89	DW102689BMSD 10/89	DW102689AMS 10/89	DW102689AMSD 10/89
VOLATILE ORGANIC COMPOUNDS (ug/l)					NA	NA
Bromoform	2Q	2Q	1J	1J		
4-methyl-3-pentanone						
Chloroform	4Q	4Q	3J	3J		
Bromodichloromethane	6	5	5	5		
Dibromochloromethane	5Q	5Q	4J	5		
EXTRACTABLE ORGANIC COMPOUNDS (ug/l)	ND	ND	NA	NA	ND	ND
Pentachlorophenol						
PESTICIDES/PCBs (ug/l)	ND	ND	ND	ND	NA	NA

PARAMETERS	SAMPLE LOCATIONS				
	DW112189 11/89	DW112189T 11/89	DW112189MS 11/89	DW112189MSD 11/89	DW0790-01 7/90
VOLATILE ORGANIC COMPOUNDS (ug/l)		ND			
Bromoform	1Q		2J	1J	2Q
4-methyl-3-pentanone					
Chloroform	4Q		4J	4J	9
Bromodichloromethane	4Q		4J	3J	9
Dibromochloromethane	4Q		4J	3J	7
EXTRACTABLE ORGANIC COMPOUNDS (ug/l)	ND	NA	NA	NA	NA
Pentachlorophenol					
PESTICIDES/PCBs (ug/l)	ND	NA	NA	NA	NA

NOTES:

J - Estimate; QA/QC parameter(s) outside acceptable limits; semi-quantitative
Q - Data below contract required quantitation limits qualitative only

NA - Not analyzed
ND - No detections

(DWORG/2.WK1)
06/01/91

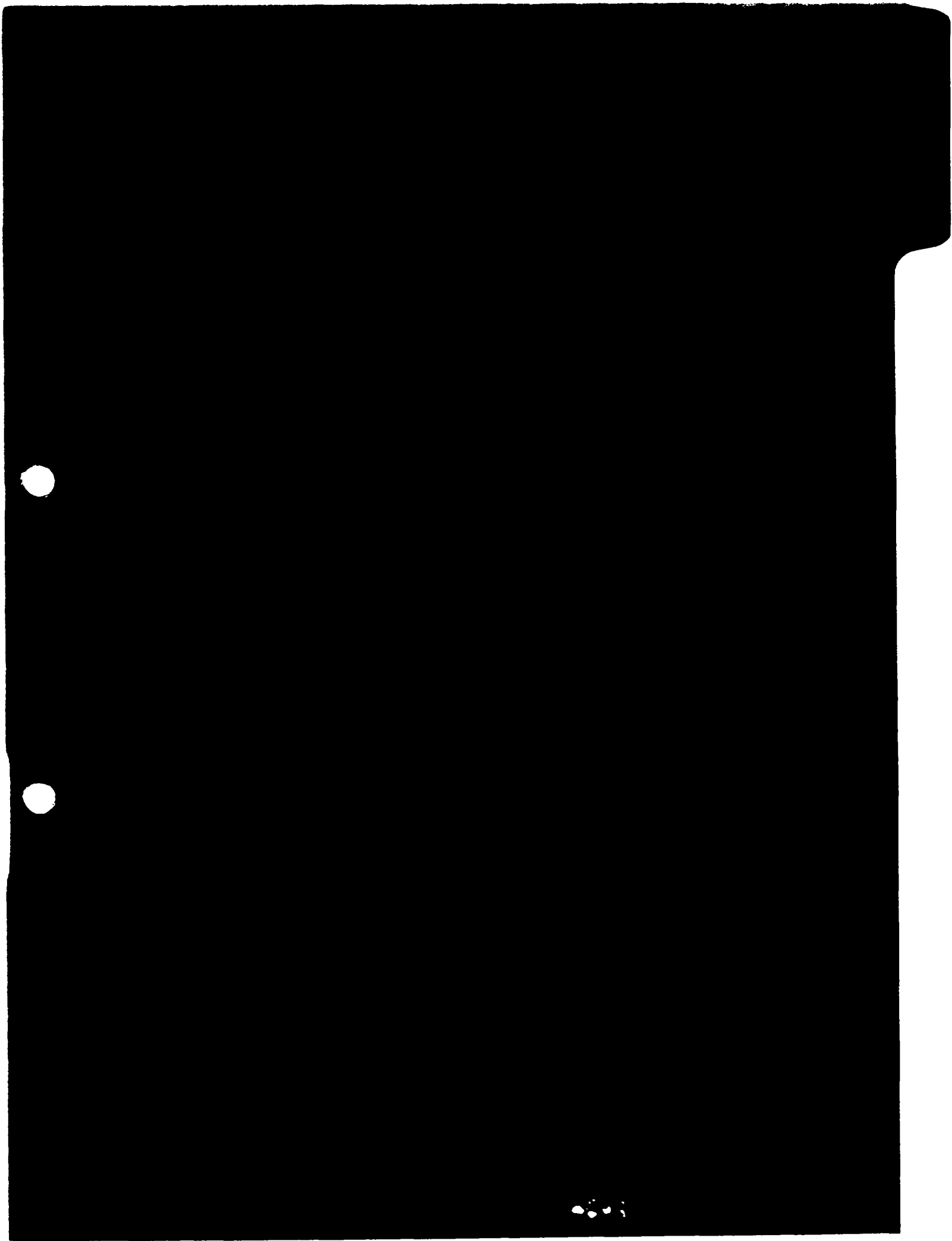

APPENDIX F

**GEOTECHNICAL LABORATORY TEST RESULTS -
LANDFILL SOIL COVER SAMPLES**

GAGE SERIAL # 12317

MODEL 3411-B 3385



NUCLEAR RELATIVE COMPACTION TEST DATA

PROJECT NAME: CRC

DATE: 7-7-89

PROJECT NO.: 00615-00-00002-02

TESTED BY: T. PROROK

CALCULATED BY: _____

CHECKED BY: _____

GT-1 GT-2 GT-3 GT-4 GT-5 GT-10 ~~GT-9~~ ~~GT-8~~ ~~GT-7~~ GT-6

TEST NUMBER	1	2	3	4	5	6	7	8	9	10
STATION	400/100	800/100	1200/000	1600/100	2000/100	400/450	800/550	1200/540	1700/500	2000/500
OFFSET	—	—	—	—	—	—	—	—	—	→
ELEVATION	N.A.	—	—	—	—	—	—	—	—	→
MODE & DEPTH	8" / NORM	—	—	—	—	—	—	—	—	→
COMPACTION METHOD	N.A.	—	—	—	—	—	—	—	—	→
NUMBER OF PASSES	N.A.	—	—	—	—	—	—	—	—	→
LIFT THICKNESS	N.A.	—	—	—	—	—	—	—	—	→
DENSITY COUNT	3244	2792	2042	2772	4707	1596	2288	1605	2643	2771
WET DENSITY (PCF)	118.7	119.8	129.5	136.3	125.5	139.1	125.4	138.4	138.6	136.9
MOISTURE COUNT	101	167	144	144	103	139	138	167	136	112
DRY DENSITY (PCF)	60.4	61.5	80.6	87.3	91.1	91.9	78.5	81.2	92.4	99.3
% MOISTURE	96.4	94.3	60.8	56.1	37.7	51.4	59.7	70.4	49.9	37.8
DEGREE OF SATURATION (%)										
MAXIMUM DRY DENSITY (PCF)										
OPTIMUM MOISTURE										
% RELATIVE COMPACTION										
MATERIAL DESCRIPTION	SANDY SILT WITH GRAVEL	CLAYEY SILT w/ SAND ^{some} gravel	SANDY SILT WITH GRAVEL	SANDY SILT WITH GRAVEL	SANDY SILT WITH GRAVEL	SANDY SILT WITH GRAVEL	SANDY SILT WITH GRAVEL	SANDY SILT WITH GRAVEL	SANDY SILT WITH GRAVEL	SANDY SILT WITH GRAVEL
STANDARD COUNT		REMARKS: READINGS TAKEN AT SUNNY-dry 70's-80's INSTD soil measurements FOR CAP. NOTE: A PERVASIVE PRESENCE OF METHANE GAS ON THE SITE AND IN THE SOIL (AND METHANE'S ASSOCIATED HYDROGEN) HAS CAUSED THE DENSOMETER TO MISREAD MOISTURE CONTENTS. Those on this data sheet should be disregarded AND LABORATORY DATA SHOULD BE INSERTED (FOR M.C.) WHEN INTERPRETING DATA FROM 12% TO 22% visual estimates place m.c.								
DENSITY	3304									
MOISTURE	599									

**GEOTECHNICAL LABORATORY TEST RESULTS
COMPACTION AND PHYSICAL
PROPERTIES TESTING
CARDINGTON ROAD**

JOB NO. 00615-00-00002-02

PERFORMED FOR:

Hart Engineers, Inc.
Penn Center West III
Suite 106
Pittsburgh, PA 15276

PERFORMED BY:

J&L Testing Company, Inc.
938 South Central Avenue
Canonsburg, PA 15317

AUGUST 24, 1989

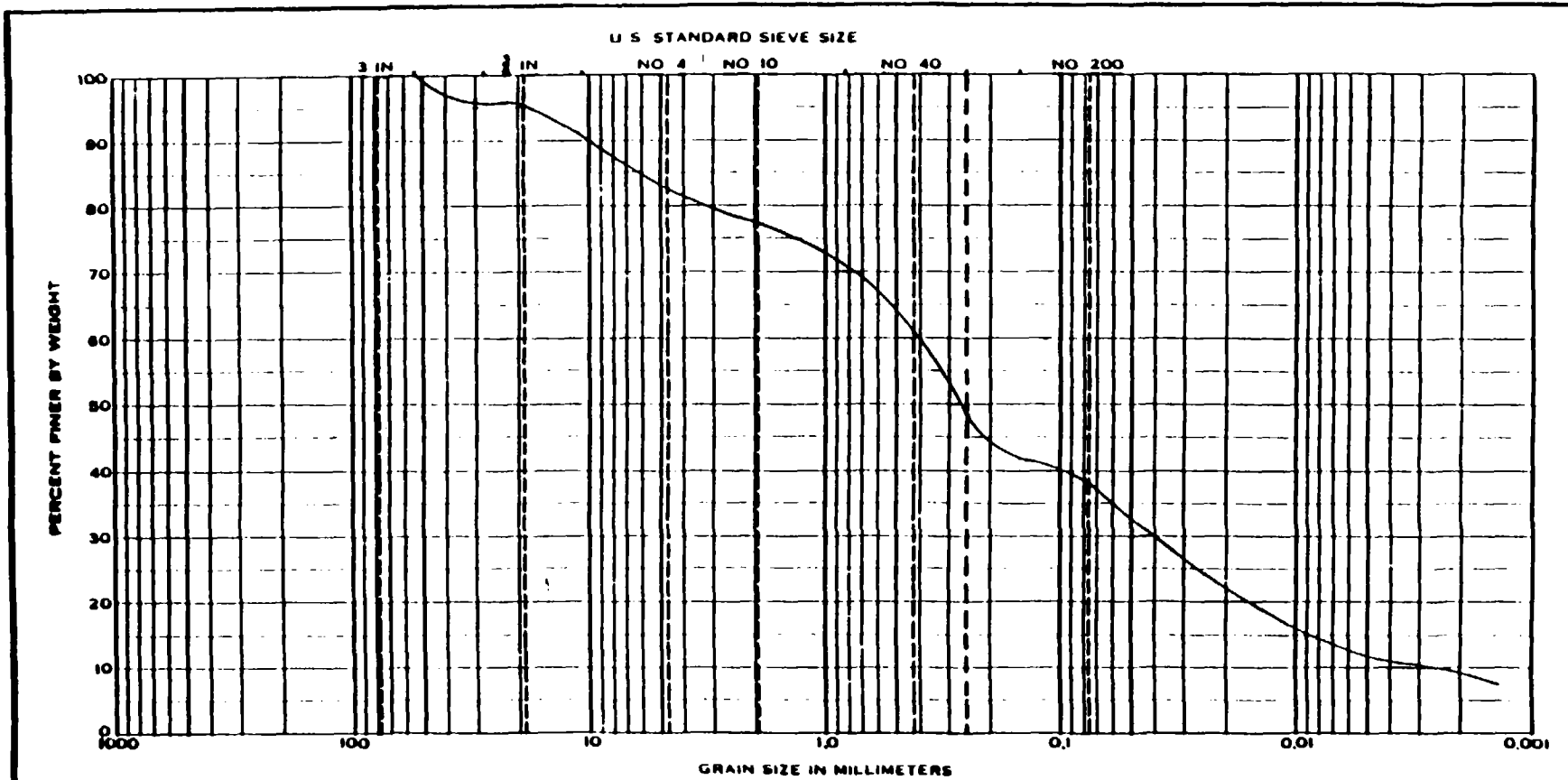

COBBLES	GRAVEL		SAND			SILT OR CLAY
	Coarse	Fine	Coarse	Medium	Fine	

Sample No.	Elev or Depth	Classification	NatWC	LL	PL	PI	Project
GT-2		SM/SC <i>M. Laves/Hart</i>	7.9				HART ENGINEERS, INC. CARDINGTON ROAD

GRADATION CURVES

Date 8-18-89

Job No 89S618-01



J & L TESTING COMPANY INC.

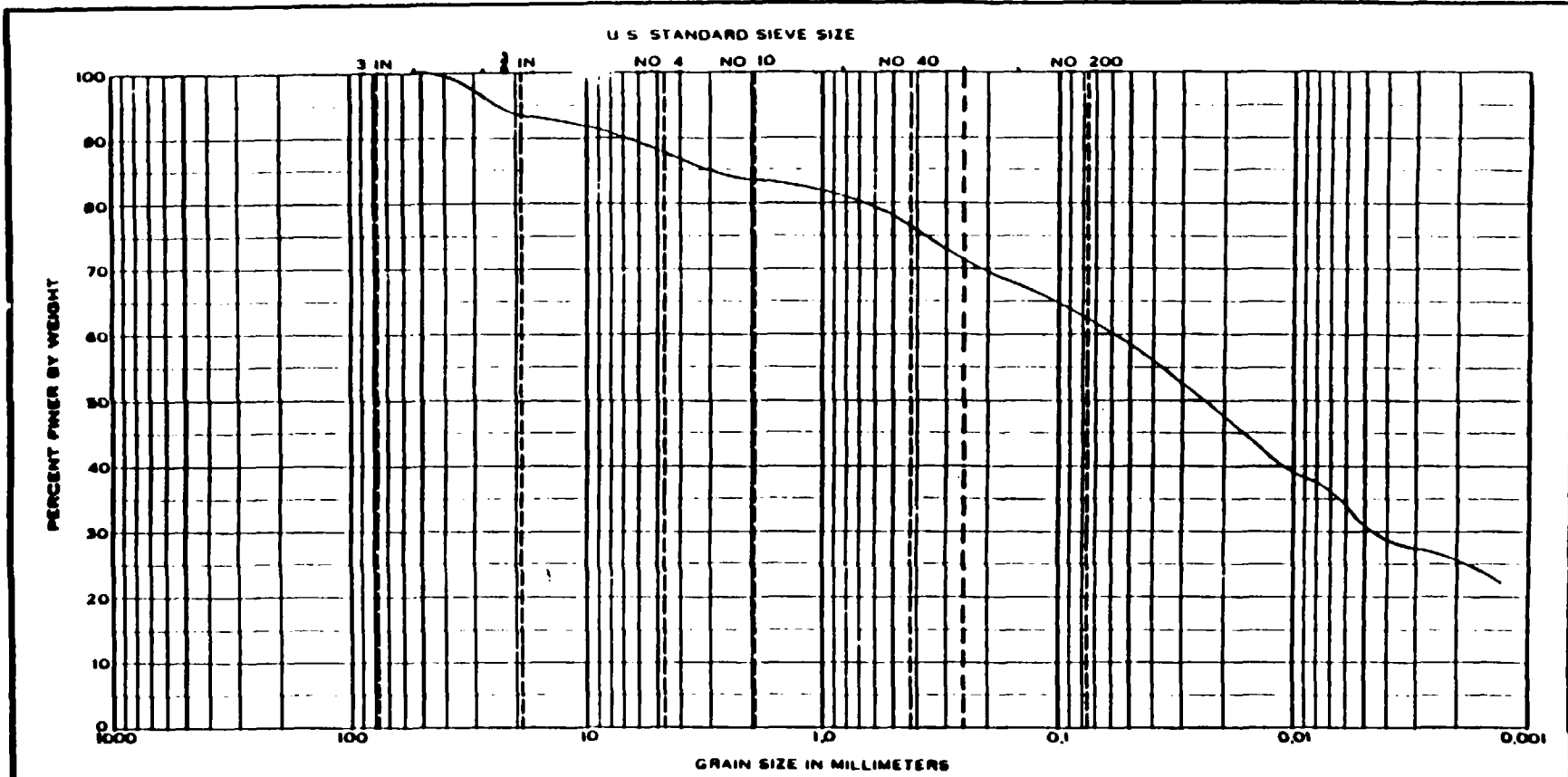

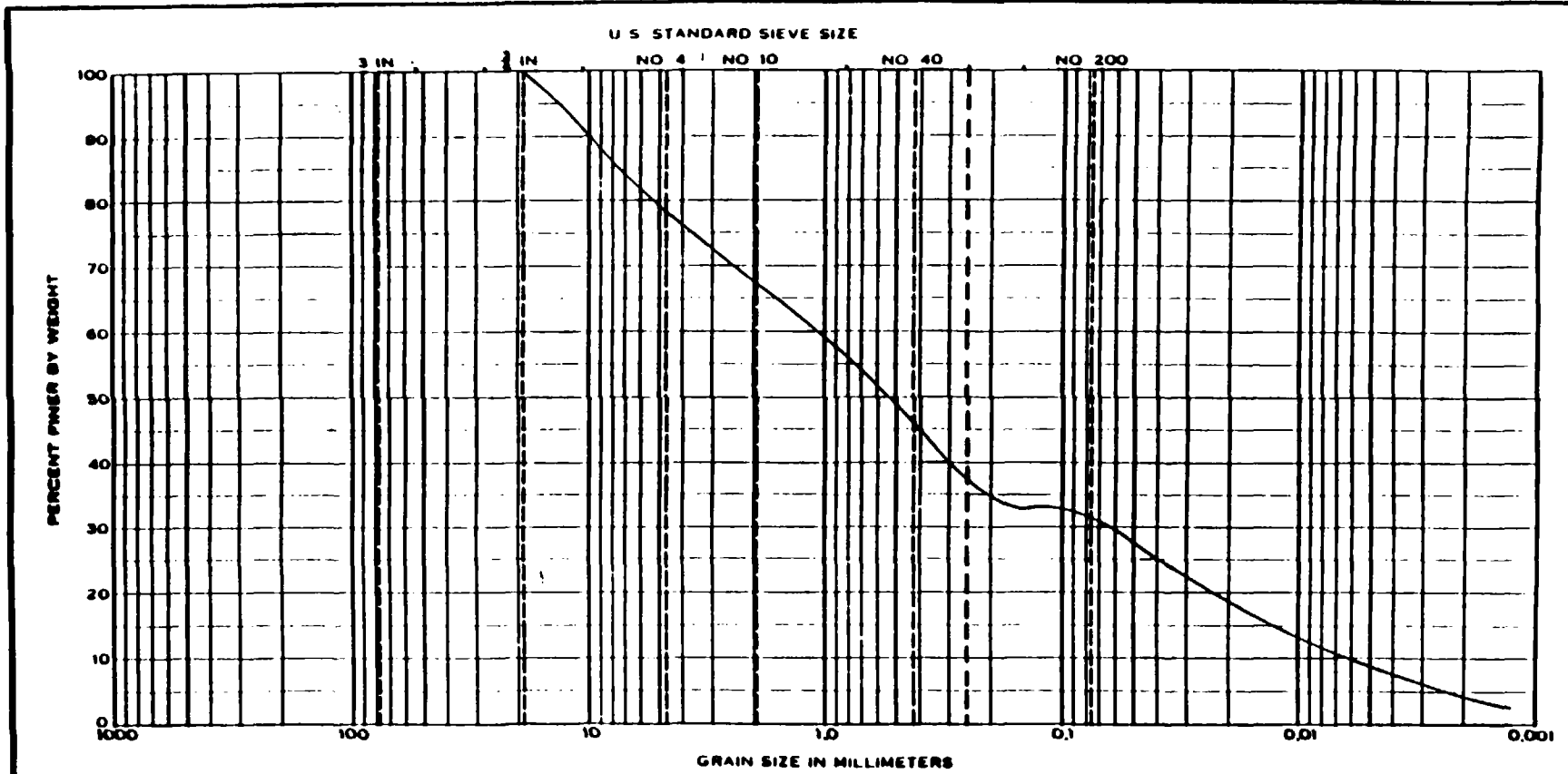

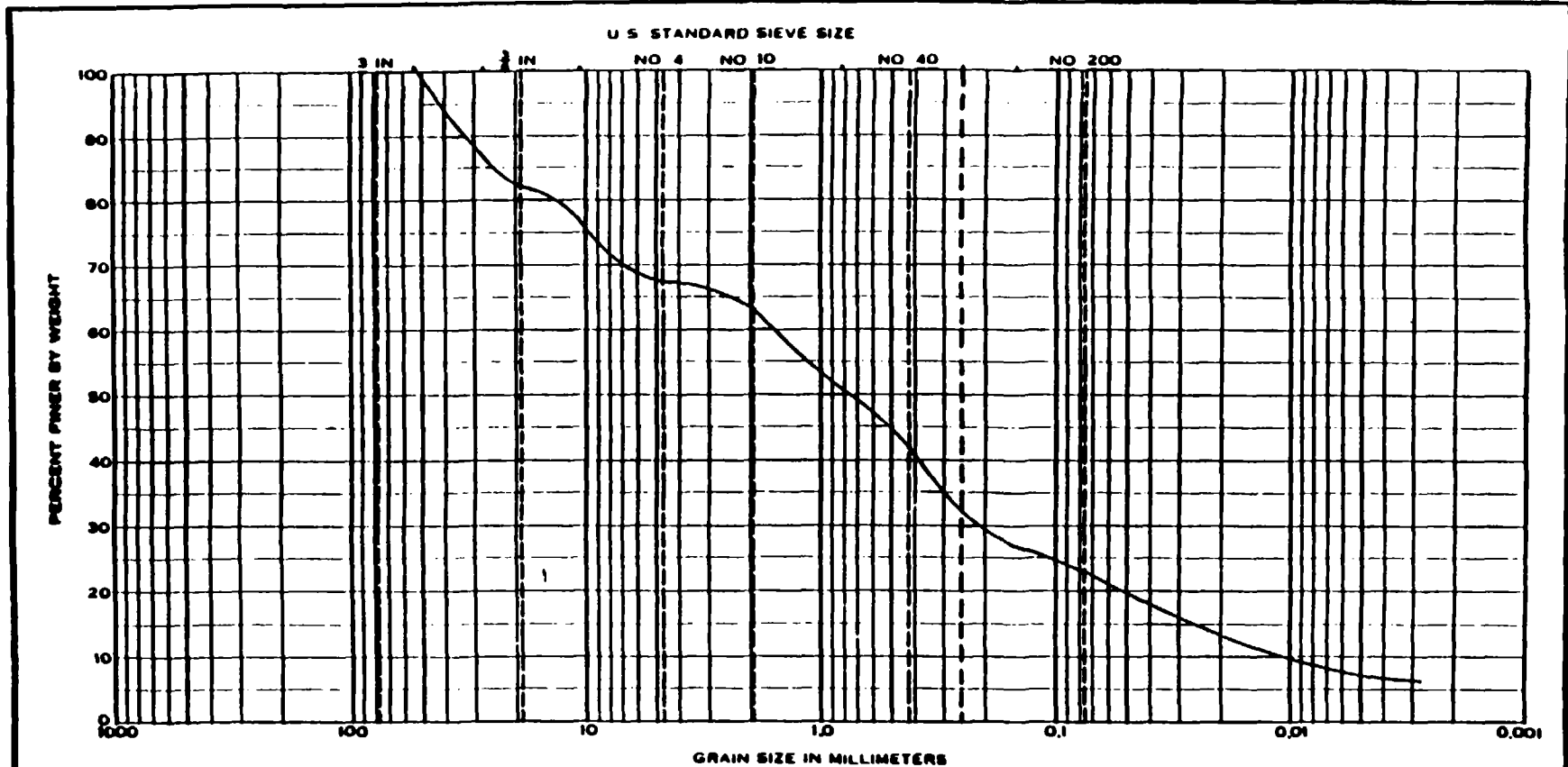

COBBLES	GRAVEL		SAND			SILT OR CLAY
	Coarse	Fine	Coarse	Medium	Fine	

Sample No.	Elev or Depth	Classification	NatWC	LL	PL	PI	Project
GT-7		<i>SM/SC</i> <i>McLain & Hales</i>	5.2				HART ENGINEERS, INC. CARDINGTON ROAD

GRADATION CURVES

Date 8-18-89 Job No 89S618-01



J & L TESTING COMPANY, INC.

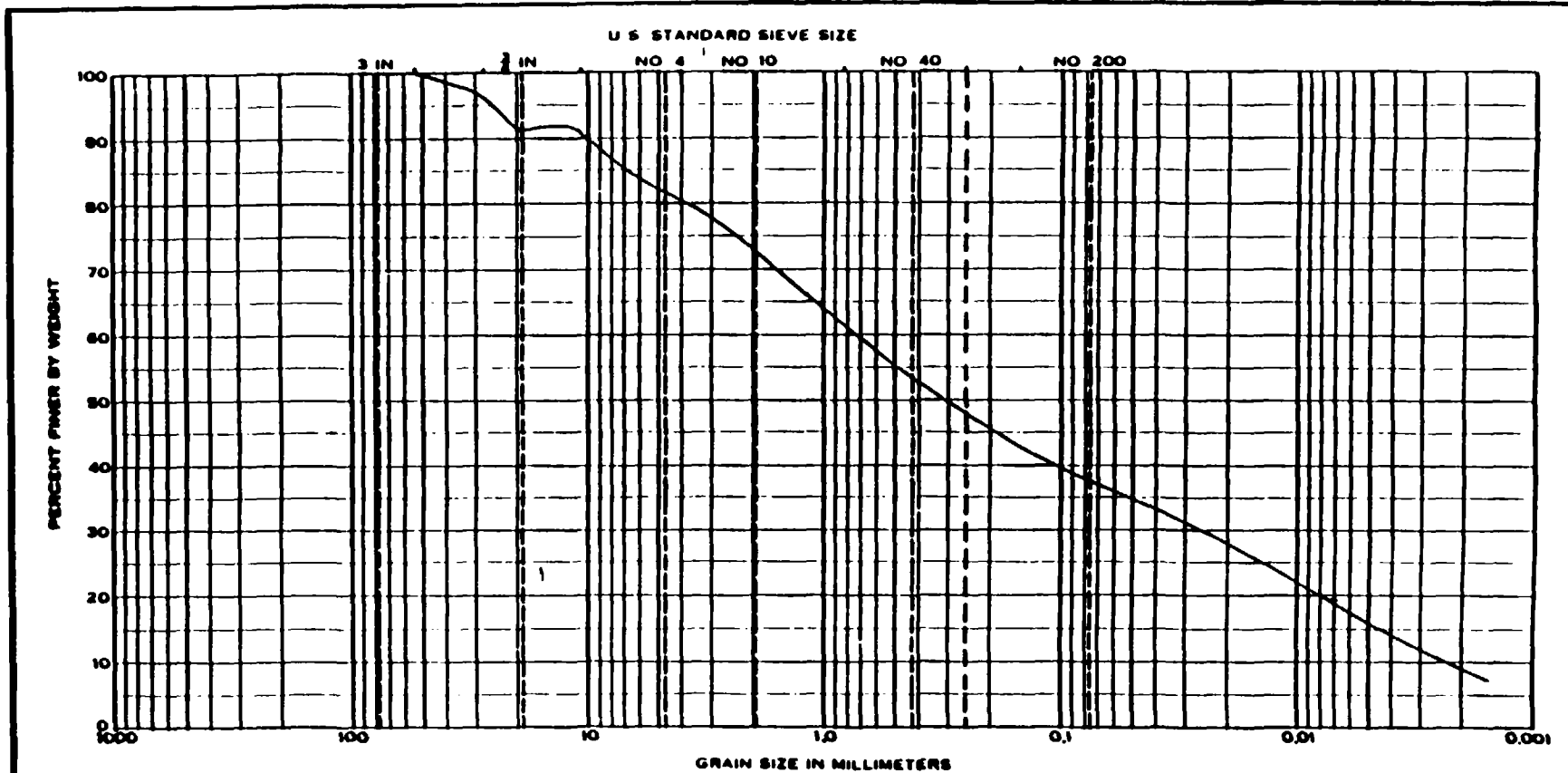

Sample No.	Elev or Depth	Classification	Nat WC	GRAVEL			SAND			SILT OR CLAY
				Coarse	Fine	Coarse	Medium	Fine		
GT-9		SM/SC McLaren/Hart	6.9							

Project HART ENGINEERS, INC.	
CARDINGTON ROAD	
Date 8-18-89	Job No 895618-01

GRADATION CURVES



J & L TESTING COMPANY INC.

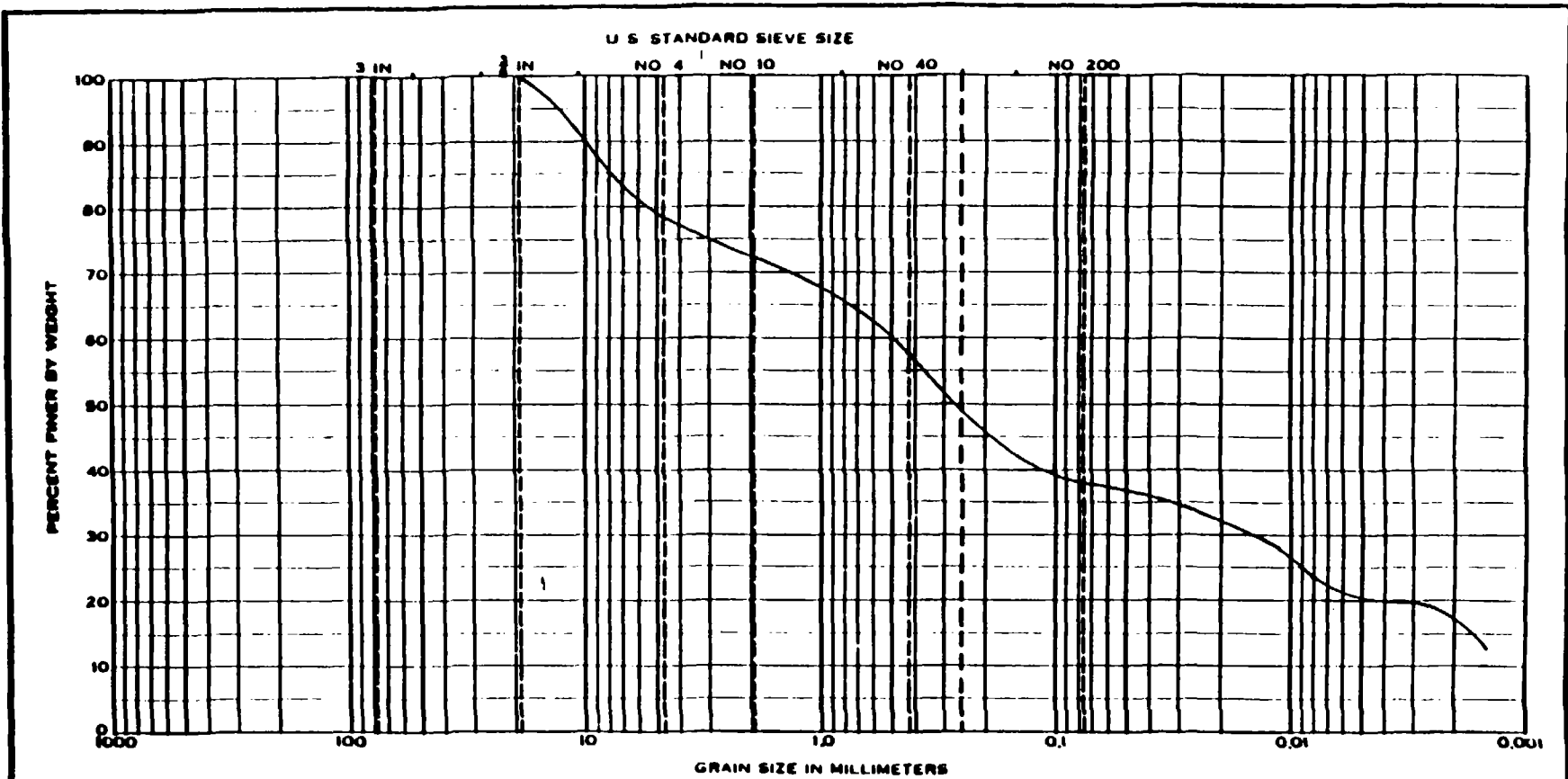

COBBLES	GRAVEL		SAND			SILT OR CLAY
	Coarse	Fine	Coarse	Medium	Fine	

Sample No.	Elev or Depth	Classification	NatWC	LL	PL	PI
GT-10		SM-SC <i>McLane / Hart</i>	5.2			

Project **HART ENGINEERS, INC.**
CARDINGTON ROAD

GRADATION CURVES

Date **8-18-89** Job No **89S618-01**



J & I TESTING COMPANY INC.



J & L TESTING COMPANY, INC.
Geotechnical, Geophysics and Geotechnical Testing

Project Hart Engineers, Inc. Job No. 895618-01
Location of Project Cardington Road Boring No. _____ Sample No. GT-4
Description of Soil _____
Depth of Sample _____ Tested By MD Date 8-11-89

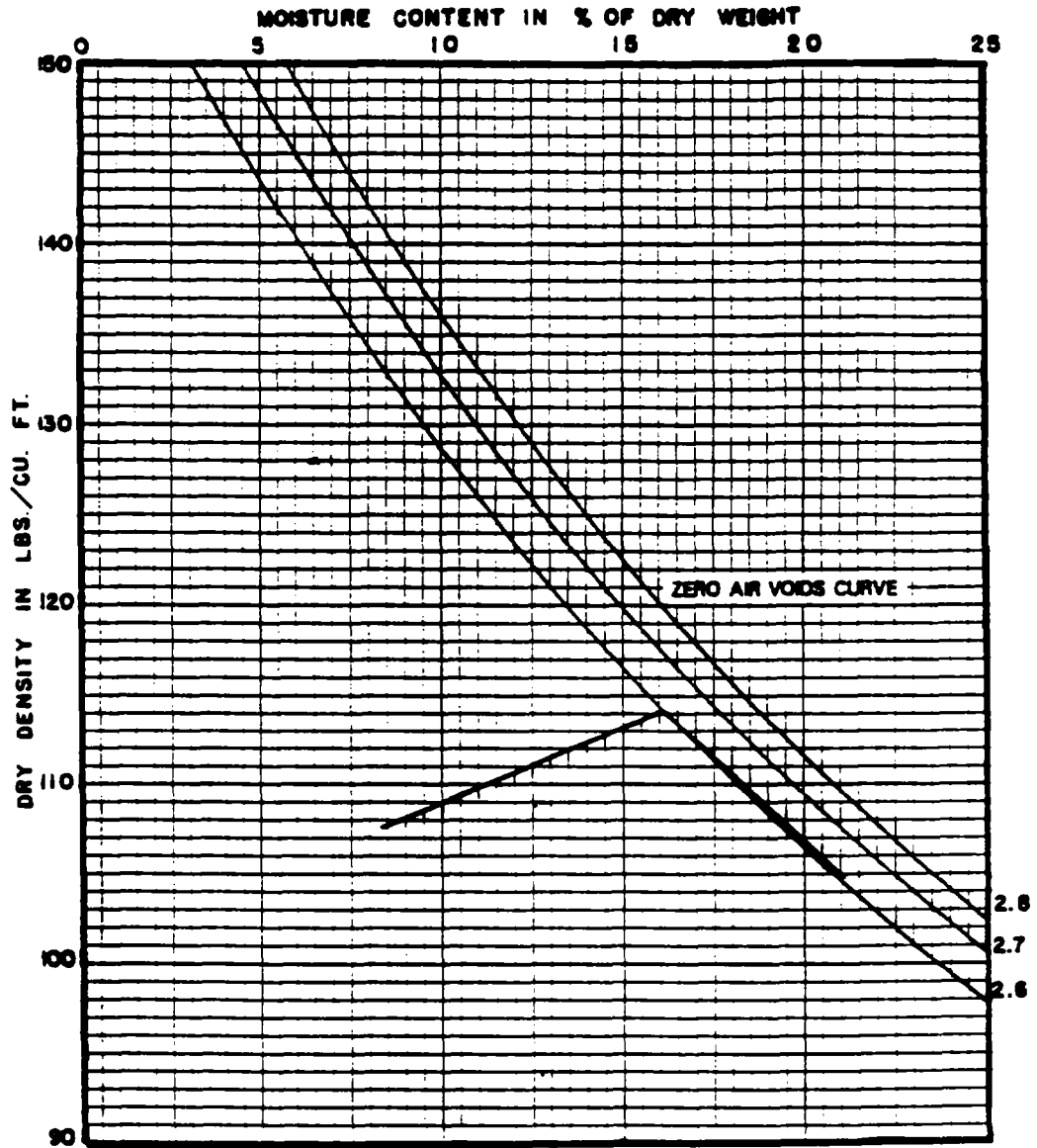

COMPACTION TEST DATA

OPTIMUM MOISTURE CONTENT 16.0%
MAXIMUM DRY DENSITY 114.0 pcf
METHOD OF COMPACTION Standard

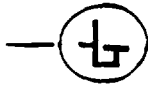

J & L TESTING COMPANY, INC.
Geotechnical, Geomembranes and Geotextiles Testing

Project Hart Engineers, Inc. Job No. 895618-01
Location of Project Cardington Road Boring No. _____ Sample No. GT-5
Description of Soil _____
Depth of Sample _____ Tested By MD Date 8-12-89

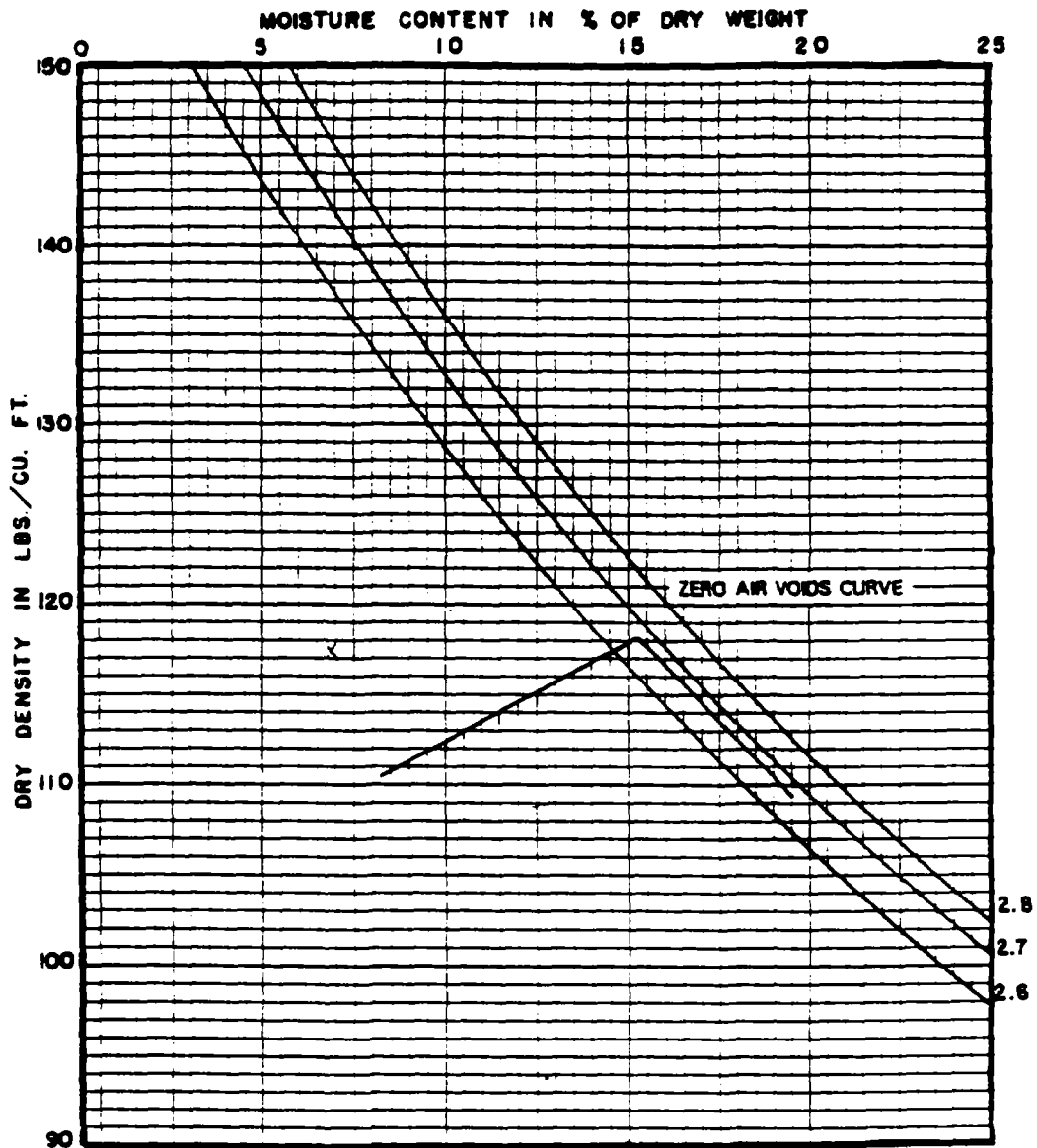

COMPACTION TEST DATA

OPTIMUM MOISTURE CONTENT 15.2%
MAXIMUM DRY DENSITY 118.0 pcf
METHOD OF COMPACTION Standard



J & L TESTING COMPANY, INC.

Geotechnical, Geotechnical and Geotechnical Testing

Project Hart Engineers, Inc. Job No. 895618-01
Location of Project Cardington Road Boring No. _____ Sample No. GT-7
Description of Soil _____
Depth of Sample _____ Tested By MD Date 8-11-89

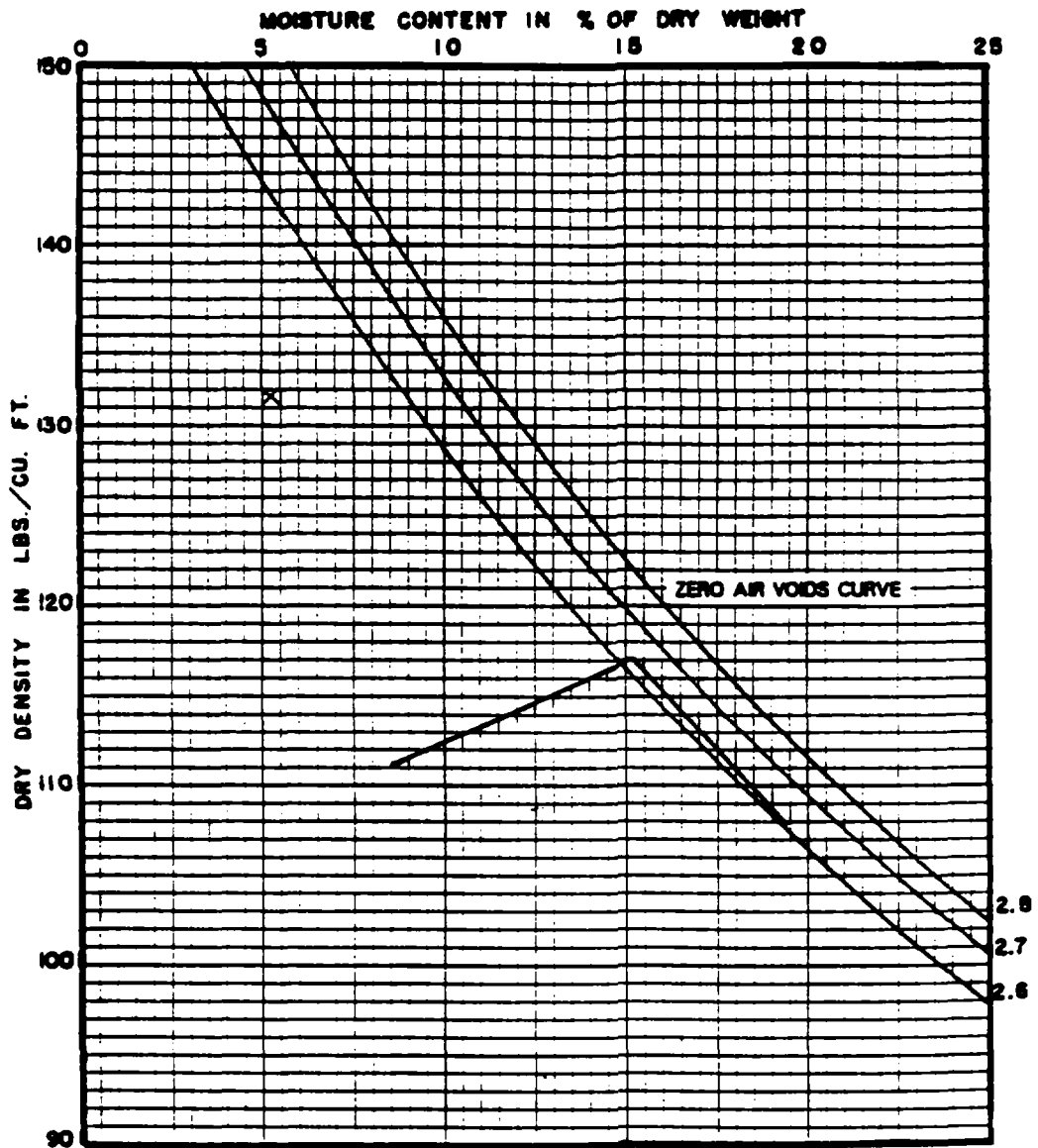

COMPACTION TEST DATA

OPTIMUM MOISTURE CONTENT 15.2%
MAXIMUM DRY DENSITY 117.0 pcf
METHOD OF COMPACTION Standard

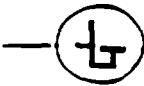

J & L TESTING COMPANY, INC.
Geotechnical, Superintendence and Geoprinting Testing

Project Hart Engineers, Inc. Job No. 89S618-01
Location of Project Cardington Road Boring No. _____ Sample No. GT-9
Description of Soil _____
Depth of Sample _____ Tested By MD Date 8-12-89

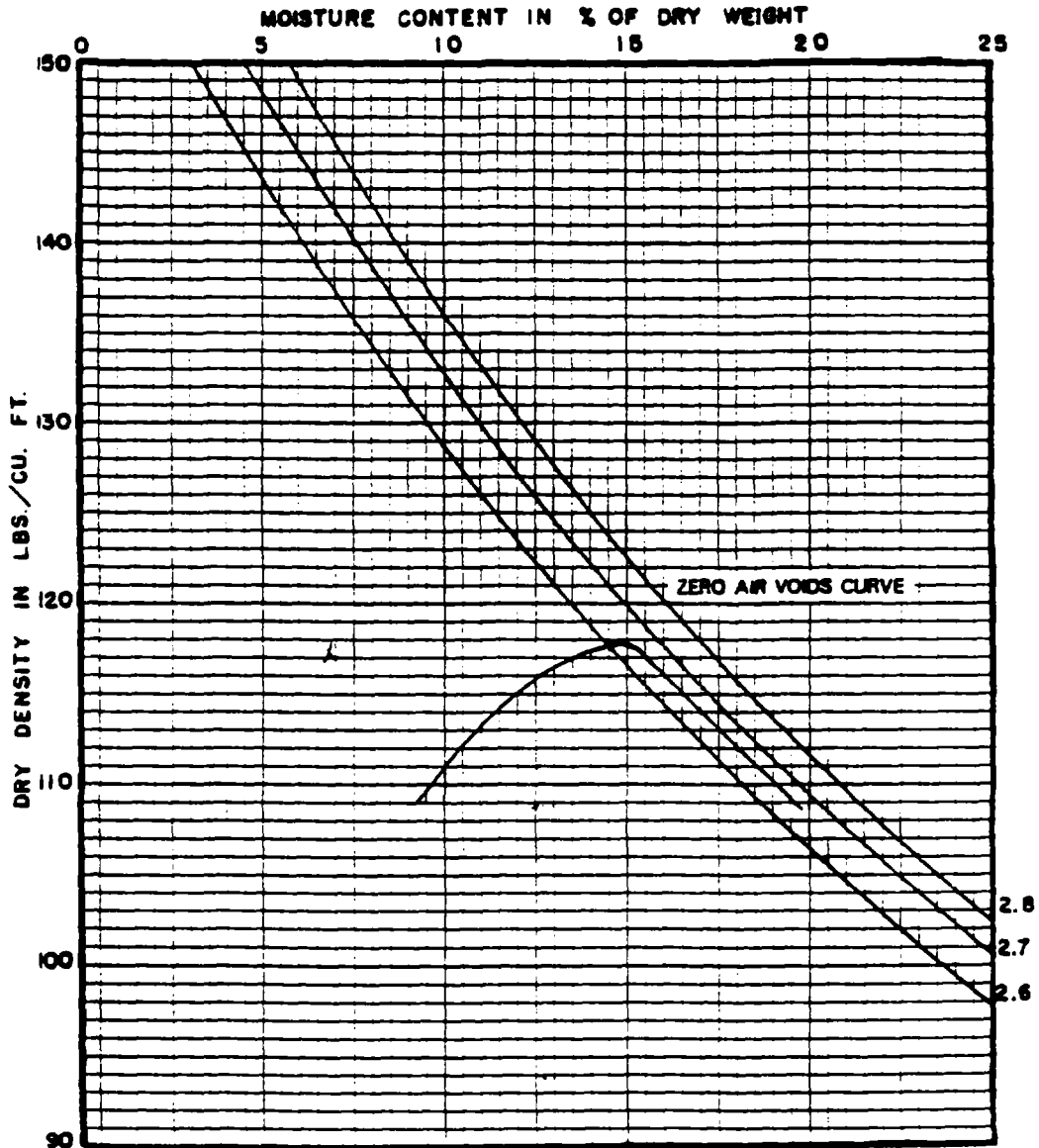

COMPACTION TEST DATA

OPTIMUM MOISTURE CONTENT 14.7%
MAXIMUM DRY DENSITY 117.9 pcf
METHOD OF COMPACTION Standard

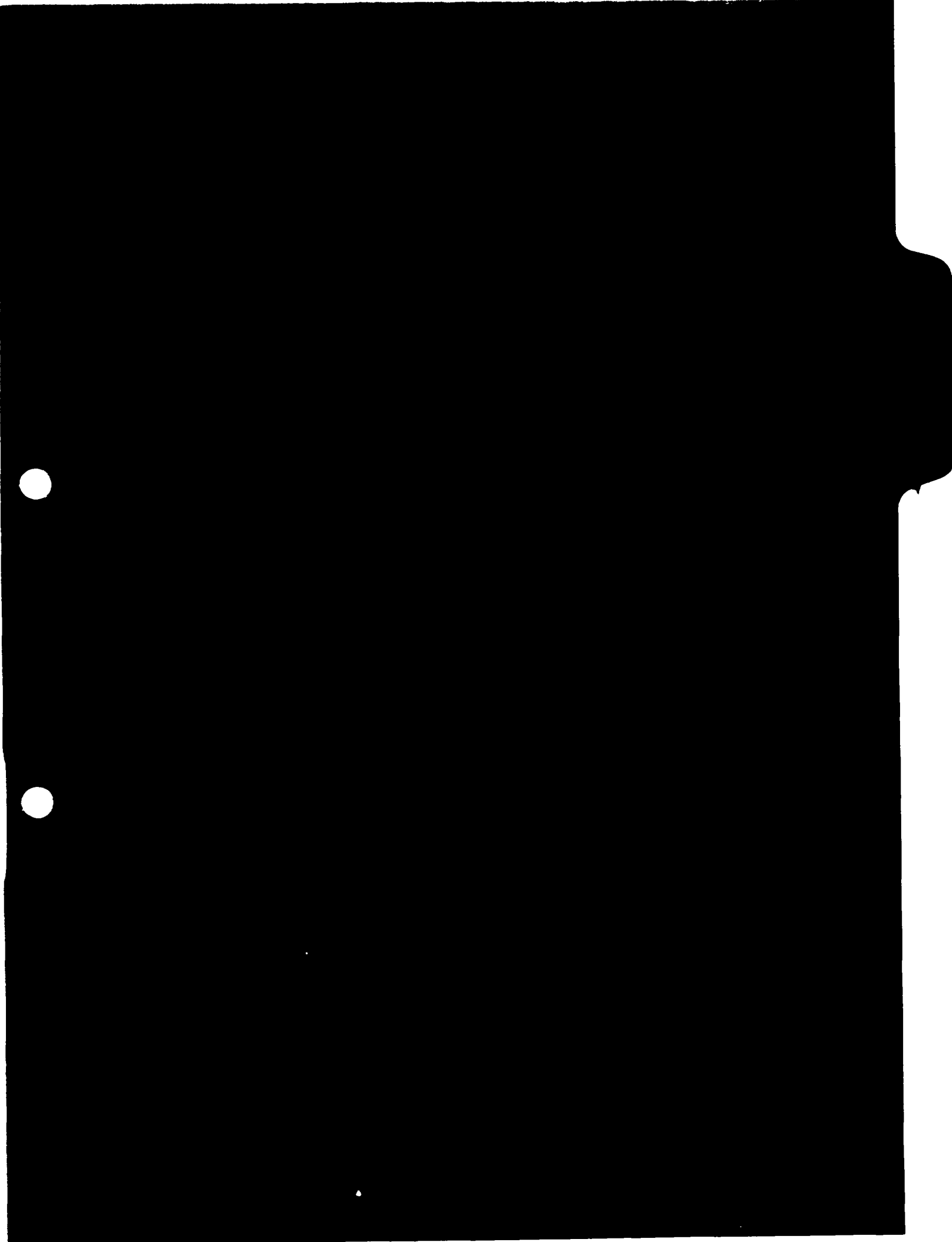

APPENDIX G

**HYDROLOGIC EVALUATION OF LANDFILL PERFORMANCE (HELP)
MODEL SIMULATIONS**

BY MHR/IT DATE 4/25/91
CHK'D SSR DATE 4-29-91

HART ENGINEERS, INC.

SHEET 1 OF 8
PAGE

SUBJECT Cardington Road Landfill
Cover Integrity Study

JOB NO. PT059

PROBLEM STATEMENT:

Using field data and the H.E.L.P. computer model, estimate leachate flow through the landfill.

REFERENCES:

- 1) Geotechnical Laboratory Test Results on Samples from GT-1 through GT-10, by J-L Testing Co., Inc. dated 2/24/89
- 2) Nuclear Densometer Compaction Test Data, tests conducted by T. Prosek, 7/7/89.
- 3) McLaren/Hart Drawing No. Plate 21/C titled "Approximate Boundary of Landfill," draft version stamped 4/10/91
- 4) HELP 2 - Users Manual, 10/26/88
- 5) Temperature and precipitation data obtained from the NWS - Weather Information and Records.

BY NMT DATE 4/24/91
CHK'D SSA DATE 9-29-91

HART ENGINEERS, INC.

SHEET 2 OF 8
PAGE

SUBJECT Cardington Road Landfill
Cover Integrity Study JOB NO. PT 059

DEVELOPMENT:

Assume the following generalized cross-section

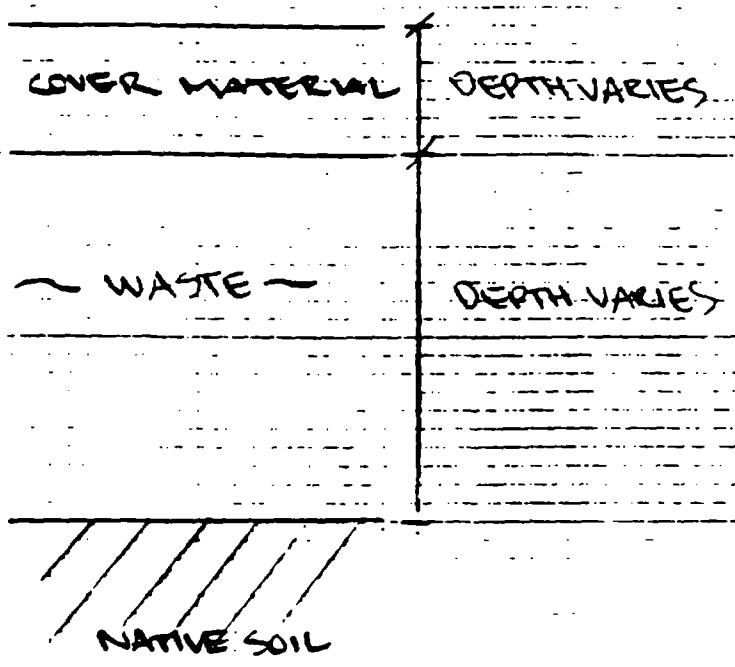

Use data obtained from field study to define soil type, moisture and depth of cover material and depth and bottom slope of waste mass. Field data summarized on sheet 3. Locations of the test pits and borings are shown on drawing listed as ref. 3.

BY DATE 11/25/11
 CHK'D SSR DATE 4-29-91

HART ENGINEERS, INC.

SUBJECT Cardinal Road Landfill JOB NO. PT 004
Cover Investigation Study

Test Pit #	Soil Classification/ Moisture (%) ¹	In-place Dry Density (pcf) ²	In-place Wet Density (pcf) ³	Approximate Depth (ft) + Cover soil waste
GT-1	SM/SC @ 4.4%	113.7	118.7	7' / 46'
GT-2	SM/SC @ 7.9%	111.0	119.8	7' / 46'
GT-3	GM-MC/ GM-MH @ 11.1%	116.6	129.5	6.5' / 36.5'
GT-4	SM/SC @ 6.5%	128.0	136.3	7.5' / 47.5'
GT-5	SM/SC @ 6.9%	117.4	125.5	2.5' / 22.5'
GT-6	SM/SC @ 4.5%	131.0	136.9	2.5' / 22.5'
GT-7	SM/SC @ 5.2%	131.7	138.6	7.5' / 47.5'
GT-8	GM/GC @ 7.6%	128.6	138.4	6.5' / 36.5'
GT-9	SM/SC @ 6.9%	117.3	125.2	7' / 46'
GT-10	SM/SC @ 5.2%	135.2	134.1	7' / 46'

Notes:

- 1) Information obtained from Ref. 1
- 2) Calculated using γ_{d} from nuclear densometer data and moisture content (w) obtained from $w = \frac{\gamma_w}{\gamma - \gamma_w} \times 100\%$
- 3) Information obtained from Ref. 2
- 4) Information obtained from Inertive Borings (IB) located near the test pits. IB 1 used for GT 5 & 6, IB 2 used for GT 4 & 7, IB 4 used for GT 3 & 8 and IB 5 used for GT 1, 2, 9 and 10.

SUBJECT Cardington Road Landfill JOB NO. PT059.04
Cover Integrity Study

As the cover soil depth, waste depth, soil & waste water contents, soil and waste permeabilities, etc. Several cases will be evaluated.

Case 1: Minimum cover depth, maximum waste depth

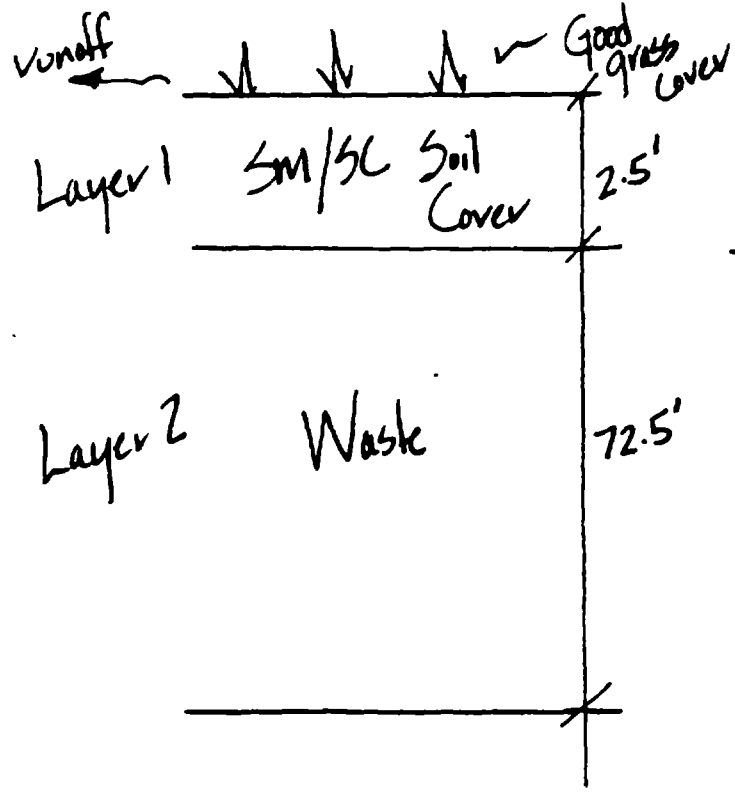

HELP INPUT DATA

- Vertical percolation layer
- Soil #7 w/wc ≈ 5.7%

- Vertical percolation layer
- Soil # 18

$$K = 2.0 \times 10^{-4} \text{ cm/sec}$$

Simulation run for five years using program default values for precipitation.

Results: Ave. annual flow - 3.1027 in./acre/yr.
 Ave. annual runoff - 0.374 in./acre/yr.

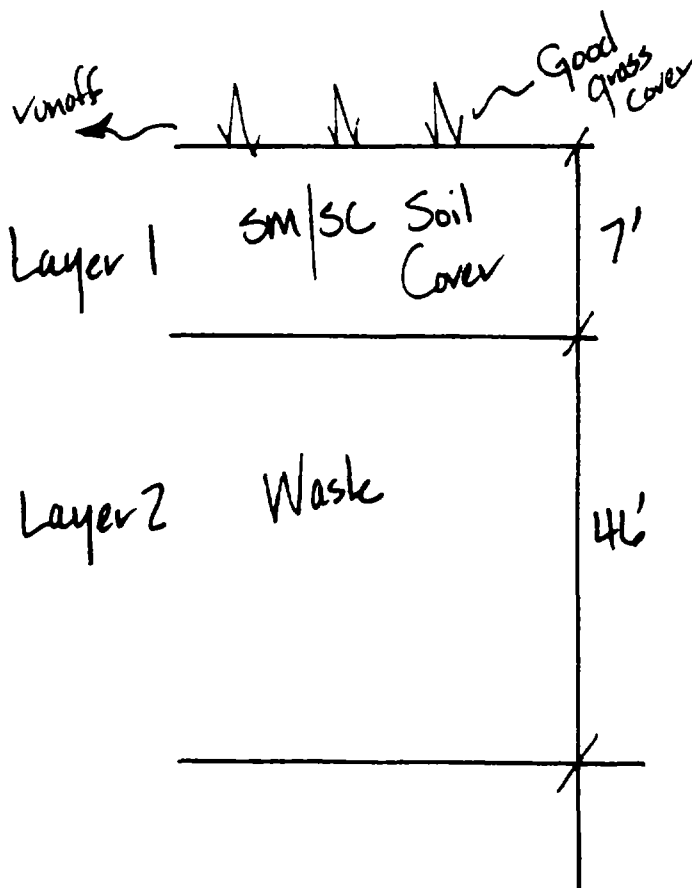
Cardington Road Landfill
Cover Integrity StudyCase: 2 Maximum cover depth, minimum waste depthHELP INPUT DATA

- Vertical percolation layer
- Soil #7 w/wc \approx 5.7%
- Vertical percolation layer
- Soil #18

$$K = 2.0 \times 10^{-4} \text{ cm/sec.}$$

Simulation run for five years using program default values for precipitation.

Results - Ave. annual flow - 2.1625 in./acre/yr
Ave. annual runoff - 0.374 in./acre/yr

SUBJECT

Cardington Road Landfill
Cover Integrity StudyJOB NO. PT059.04

Case 3: Same as Case 1 only simulation is run for twenty years using simulated precipitation data from NWS.

Results: Ave. annual flow - 4.7783 in./acre/yr
Ave annual runoff - 0.169 in./acre/yr.

Case 4: Same as Case 2 only simulation is run for twenty years using simulated precipitation data from NWS.

Results: Ave. annual flow - 4.5420 in./acre/yr
Ave annual runoff - 0.168 in./acre/yr

Case 5: Same as Case 3 only using the hydraulic conductivity value
 $k = 1.0 \times 10^{-5}$ cm/sec.

Results: Ave. annual flow - 1.5122 in./acre/yr
Ave annual runoff - 0.169 in./acre/yr

Case 6: Using output from Case 3 as input, run simulation for 20 years.
(Total 40 years)

Results: Ave annual flow - 5.9046 in./acre/yr
Ave annual runoff - 0.169 in./acre/yr

BY RSP DATE 9-4-91

HART ENGINEERS, INC.

SHEET

7 OF 8

PAGE

CHK'D DATE

SUBJECT

Cardington Road Landfill
Cover Integrity Study

JOB NO. PR059.04

Case 7: Same as Case 3 except run using default water content values.

Results: Ave annual flow - 4.9736 in/acre/yr
Ave annual runoff - 0.175 in/acre/yr

Case 8: Same as Case 1 except run repeated 4 times (total 20 years) to simulated 20 year cycle.

Results: Ave annual flow - 6.3578 in/acre/yr
Ave annual runoff - 0.378 in/acre/yr

RESULTS FOR ALL CASES ARE SUMMARIZED ON SHEET 8;
SEE APPENDIX A FOR COMPLETE COMPUTER OUTPUT FOR EACH CASE.

BY <u>RJP</u>	DATE <u>9-2-91</u>	FRED C. HART ASSOCIATES, INC.	SHEET	PAGE
CHK'D _____	DATE _____		<u>8</u> OF <u>8</u>	
SUBJECT <u>Cardington Road Landfill</u>		JOB NO. <u>PT059.04</u>		
<u>Cover Integrity Study</u>				

CASE	DESCRIPTION	RESULTS	
		Avg. Annual Flow in./acre/year	Avg. Annual Runoff in./acre/year
1	2 layer system min cover, max waste $K = 2 \times 10^{-4}$ cm/sec	3.1027	0.374
2	2 layer system max. cover, min waste $K = 2 \times 10^{-4}$ cm/sec	2.1625	0.374 ✓
3	Case 1 run for 20 years using simulated rainfall	4.7783	0.169
4	Case 2 run for 20 years using simulated rainfall	4.5420	0.168
5	Case 3 using $K = 1.0 \times 10^{-5}$ cm/sec	1.5122	0.169 ✓
6	Using Case 3 as input, simulation run for another 20 yrs.	5.9046	0.169
7	Same as Case 3 except run used default soil water content values	4.9736	0.175
8	Same as Case 1 except run repeated to simulated 20 yrs.	6.3578	0.378

DR. RJP DATE 9-4-91

CMT. 0 DATE

HART ENGINEERS, INC.

SHEET

OF PAGE

SUBJECT Cardington Road Landfill Cover Integrity Study JOB NO. PROS9.04

TABLE
DEFAULT SOIL CHARACTERISTICS

Soil Texture			Total Poros.	Resid. Sat.	Bubbl. Press. (cm)	Pore Size Dist. Index	Field Cap.	Wilt. Pt.	Sat. cm/s	Hyd. Cond. in/hr	Min. Inf. Rate in/hr	Evap. Coef. mm/day ^{0.5}
Class	USDA	USCS										
HELP												
1	CoS	GS	0.417	0.015	6.53	0.651	0.045	0.018	1.0E-02	14.173	0.500	3.3
2	S	SW	0.437	0.020	7.26	0.592	0.062	0.024	5.8E-03	8.220	0.400	3.3
3	FS	SM	0.457	0.025	7.99	0.533	0.083	0.033	3.1E-03	4.394	0.390	3.3
4	LS	SM	0.437	0.035	8.69	0.474	0.105	0.047	1.7E-03	2.409	0.380	3.3
5	LFS	SM	0.457	0.040	9.56	0.425	0.131	0.058	1.0E-03	1.417	0.340	3.3
6	SL	SM	0.453	0.041	14.66	0.322	0.190	0.085	7.2E-04	1.020	0.300	5.1
7	FSI.	SM	0.473	0.046	16.13	0.290	0.222	0.104	5.2E-04	0.737	0.250	5.1
8	L	ML	0.463	0.027	11.15	0.220	0.232	0.116	3.7E-04	0.524	0.200	3.9
9	SiL	ML	0.501	0.015	20.76	0.211	0.284	0.135	1.9E-04	0.269	0.170	5.1
10	SCL	SC	0.398	0.068	28.08	0.250	0.244	0.136	1.2E-04	0.170	0.110	5.1
11	CL	CL	0.464	0.075	25.89	0.194	0.310	0.187	6.4E-05	0.091	0.090	5.1
12	SiCL	CL	0.471	0.040	32.56	0.151	0.342	0.210	4.2E-05	0.060	0.070	5.1
13	SC	CH	0.430	0.109	29.17	0.168	0.321	0.221	3.3E-05	0.047	0.060	4.5
14	SiC	CH	0.479	0.056	34.19	0.127	0.371	0.251	2.5E-05	0.035	0.020	5.1
15	C	CH	0.475	0.090	37.30	0.131	0.378	0.265	1.7E-05	0.024	0.010	4.6
16	Barrier		0.430	0.120	45.00	0.113	0.366	0.280	1.0E-07	0.000	0.002	3.3
17	Barrier		0.400	0.140	50.00	0.096	0.356	0.290	1.0E-08	0.000	0.001	3.3
18	Mun. Waste		0.520	0.015	20.76	0.211	0.294	0.140	2.0E-04	0.283	0.230	5.1

FROM Reference 4

CLIMATOLOGICAL DATA INPUT

Synthetic Precipitation Option

FROM
Reference 5.

Location: Dayton OH

Number of Years to Be Generated: -

Normal Mean Monthly Temperatures
in Degrees Fahrenheit (Optional)

Normal Mean Monthly Precipitation
in Inches (Optional)

Jan.	<u>26.6</u>
Feb.	<u>29.6</u>
Mar.	<u>39.5</u>
Apr.	<u>51.5</u>
May	<u>61.8</u>
Jun.	<u>71.0</u>
Jul.	<u>74.6</u>
Aug.	<u>73.0</u>
Sep.	<u>66.3</u>
Oct.	<u>54.5</u>
Nov.	<u>42.1</u>
Dec.	<u>31.8</u>

Jan.	<u>2.57</u>
Feb.	<u>2.11</u>
Mar.	<u>3.08</u>
Apr.	<u>3.43</u>
May	<u>3.69</u>
Jun.	<u>3.81</u>
Jul.	<u>3.37</u>
Aug.	<u>3.10</u>
Sep.	<u>2.39</u>
Oct.	<u>2.01</u>
Nov.	<u>2.64</u>
Dec.	<u>2.51</u>

Maximum Leaf Area Index: -

Evaporative Zone Depth in Inches: -

- 1) Normal Mean Monthly Precipitation in terms of water equivalent.
- 2) Temperature and precipitation data obtained from the NWS - Weather Information and Records (Pittsburgh) on August 1, 1991.

RM 01/191

BY RJP DATE 9-4-91

HART ENGINEERS, INC.

SHEET

OF

PAGE

SUBJECT

Cardington Road Landfill
Cover Integrity Study

JOB NO. PT059.04

APPENDIX A

BY RJP DATE 9-4-91

HART ENGINEERS, INC.

SHEET

A-1
PAGE

CNN'D _____ DATE _____

SUBJECT Cardington Road Landfill JOB NO. PT059.04
Moraine, Ohio
Case 1 Simulation

DEFAULT SOIL AND DESIGN DATA INPUT

Title: Cardington Road Landfill
Case 1 - Minimum cover; maximum waste

Do you want the program to initialize the soil water? No

Number of layers: 2

Layer data:

Layer 1

- (a) thickness 30" inches
- (b) layer type 1 - vert. perc. (1 or 2)
- (c) liner leakage fraction (only for layer type 4) - (0 to 1)
- (d) soil texture number #7 (1 to 20)*
- (e) compacted? (only for soil textures 1 to 15) Y (Yes or No)
- (f) initial soil water content (not asked if program is to initialize the soil water or if layer type is 3 or 4) 0.057 vol/vol
(must be between wilting point and porosity) (actual)

Layer 2

- (a) thickness 870" inches
- (b) layer type 1 - vert. perc. (1 to 4)
- (c) liner leakage fraction (only for layer type 4) - (0 to 1)
- (d) soil texture number #1B (1 to 20)*
- (e) compacted? (only for soil textures 1 to 15) N (Yes or No)
- (f) initial soil water content (not asked if program is to initialize the soil water or if layer type is 3 or 4) 0.2942 vol/vol
(must be between wilting point and porosity) (default)

Layer 3

- (a) thickness _____ N/A inches
- (b) layer type _____
- (c) liner leakage fraction (only for layer type 4) _____ (0 to 1)
- (d) soil texture number _____ (1 to 20)*
- (e) compacted? (only for soil textures 1 to 15) _____ (Yes or No)
- (f) initial soil water content (not asked if program is to initialize the soil water or if layer type is 3 or 4) _____ vol/vol
(must be between wilting point and porosity)

Layer 4

- (a) _____
- (b) _____
- (c) _____
- (d) _____
- (e) _____
- (f) _____

Layer 5

- (a) _____
- (b) _____
- (c) _____
- (d) _____
- (e) _____
- (f) _____

Layer 6

- (a) _____
- (b) _____
- (c) _____
- (d) _____
- (e) _____
- (f) _____

BY RJP DATE 9-4-91

HART ENGINEERS, INC.

SHEET

A-2

OF

PAGE

CHK'D _____ DATE _____

SUBJECT Cardington Road Landfill JOB NO. PT059.04
Cover Integrity Study

<u>Layer 7</u>			<u>Layer 8</u>			<u>Layer 9</u>			
(a)	_____	(a)	_____	(a)	_____	(b)	_____	(b)	_____
(b)	_____	(b)	_____	(b)	_____	(c)	_____	(c)	_____
(c)	_____	(c)	_____	(c)	_____	(d)	_____	(d)	_____
(d)	_____	(d)	_____	(d)	_____	(e)	_____	(e)	_____
(e)	_____	(e)	_____	(e)	_____	(f)	_____	(f)	_____
(f)	_____	(f)	_____	(f)	_____				
<u>Layer 10</u>			<u>Layer 11</u>			<u>Layer 12</u>			
(a)	_____	(a)	_____	(a)	_____	(b)	_____	(b)	_____
(b)	_____	(b)	_____	(b)	_____	(c)	_____	(c)	_____
(c)	_____	(c)	_____	(c)	_____	(d)	_____	(d)	_____
(d)	_____	(d)	_____	(d)	_____	(e)	_____	(e)	_____
(e)	_____	(e)	_____	(e)	_____	(f)	_____	(f)	_____
(f)	_____	(f)	_____	(f)	_____				

If soil texture number of layer 1 is between 1 and 15, enter:
Type of vegetation: 4 (1 to 5)
SCS runoff curve number (optional): — (0 to 100)

If the soil texture number of layer 1 is between 16 and 20, enter:
SCS runoff curve number: — (0 to 100)

If landfill is open, enter potential runoff fraction: No (0 to 1)

Surface area: 43,560 square feet

Slope of top liner/drain system: — percent
Distance from crest to drain in top liner/drain system: _____ feet

Slope of second liner/drain system: — percent
Distance from crest to drain in second liner/drain system: _____ feet

Slope of third liner/drain system: — percent
Distance from crest to drain in third liner/drain system: _____ feet

Slope of fourth liner/drain system: — percent
Distance from crest to drain in fourth liner/drain system: _____ feet

Initial quantity of snow or ice water on surface (not asked if program is to initialize the soil water): 0.0 inches

* If soil texture number is 19:	If soil texture number is 20:
(a) wilting point _____ vol/vol	(a) wilting point _____ vol/vol
(b) field capacity _____ vol/vol	(b) field capacity _____ vol/vol
(c) porosity _____ vol/vol	(c) porosity _____ vol/vol
(d) saturated hydraulic conductivity _____ cm/sec	(d) saturated hydraulic conductivity _____ cm/sec

CARDINGTON ROAD LANDFILL
 MORaine, OHIO
 SEPTEMBER 4, 1991

CASE 1

GOOD GRASS

LAYER 1

VERTICAL PERCOLATION LAYER

THICKNESS	=	30.00 INCHES
POROSITY	=	0.3808 VOL/VOL
FIELD CAPACITY	=	0.1924 VOL/VOL
WILTING POINT	=	0.1043 VOL/VOL
INITIAL SOIL WATER CONTENT	=	0.0570 VOL/VOL
SATURATED HYDRAULIC CONDUCTIVITY	=	0.000109200002 CM/SEC

LAYER 2

VERTICAL PERCOLATION LAYER

THICKNESS	=	870.00 INCHES
POROSITY	=	0.5200 VOL/VOL
FIELD CAPACITY	=	0.2942 VOL/VOL
WILTING POINT	=	0.1400 VOL/VOL
INITIAL SOIL WATER CONTENT	=	0.2942 VOL/VOL
SATURATED HYDRAULIC CONDUCTIVITY	=	0.000199999980 CM/SEC

GENERAL SIMULATION DATA -----

SCS RUNOFF CURVE NUMBER	=	66.43
TOTAL AREA OF COVER	=	43560. SQ FT
EVAPORATIVE ZONE DEPTH	=	21.00 INCHES

UPPER LIMIT VEG. STORAGE = 7.9968 INCHES
 INITIAL VEG. STORAGE = 1.1970 INCHES
 INITIAL SNOW WATER CONTENT = 0.0000 INCHES
 INITIAL TOTAL WATER STORAGE IN SOIL AND WASTE LAYERS = 257.6640 INCHES

SOIL WATER CONTENT INITIALIZED BY USER.

CLIMATOLOGICAL DATA

DEFAULT RAINFALL WITH SYNTHETIC DAILY TEMPERATURES AND SOLAR RADIATION FOR COLUMBUS OHIO

MAXIMUM LEAF AREA INDEX = 3.30
 START OF GROWING SEASON (JULIAN DATE) = 121
 END OF GROWING SEASON (JULIAN DATE) = 286

NORMAL MEAN MONTHLY TEMPERATURES, DEGREES FAHRENHEIT

JAN/JUL	FEB/AUG	MAR/SEP	APR/OCT	MAY/NOV	JUN/DEC
27.10	29.80	40.00	51.40	61.40	70.20
73.80	72.40	65.80	53.90	42.10	32.10

AVERAGE MONTHLY VALUES IN INCHES FOR YEARS 74 THROUGH 78

	JAN/JUL	FEB/AUG	MAR/SEP	APR/OCT	MAY/NOV	JUN/DEC
PRECIPITATION						
TOTALS	3.23	1.83	3.50	2.77	2.56	4.05
	2.67	4.76	3.16	2.48	1.96	3.12
STD. DEVIATIONS	1.60	1.20	0.91	0.93	1.41	0.69
	1.56	0.23	1.61	0.63	1.09	1.48
RUNOFF						
TOTALS	0.174	0.046	0.040	0.000	0.000	0.017
	0.007	0.045	0.015	0.014	0.003	0.014
STD. DEVIATIONS	0.388	0.103	0.063	0.000	0.000	0.028
	0.016	0.097	0.032	0.019	0.007	0.030
EVAPOTRANSPIRATION						
TOTALS	0.670	1.255	2.163	2.713	2.723	5.444
	3.107	3.742	3.567	1.845	1.283	0.666

STD. DEVIATIONS	0.205	0.295	0.299	0.777	0.895	1.271
	1.515	0.788	0.660	0.239	0.140	0.105

PERCOLATION FROM LAYER 2

TOTALS	0.2420	0.2352	0.2672	0.2637	0.2735	0.2631
	0.2693	0.2664	0.2549	0.2604	0.2491	0.2579

STD. DEVIATIONS	0.0502	0.0590	0.0622	0.0583	0.0595	0.0569
	0.0579	0.0568	0.0538	0.0545	0.0516	0.0541

AVERAGE ANNUAL TOTALS & (STD. DEVIATIONS) FOR YEARS 74 THROUGH 78

	(INCHES)	(CU. FT.)	PERCENT
PRECIPITATION	36.09 (2.628)	131021.	100.00
RUNOFF	0.374 (0.338)	1357.	1.04
EVAPOTRANSPIRATION	29.178 (1.053)	105917.	80.84
PERCOLATION FROM LAYER 2	3.1027 (0.6634)	11263.	8.60
CHANGE IN WATER STORAGE	3.439 (3.234)	12484.	9.53

PEAK DAILY VALUES FOR YEARS 74 THROUGH 78

	(INCHES)	(CU. FT.)
PRECIPITATION	2.32	8421.6
RUNOFF	0.867	3147.2
PERCOLATION FROM LAYER 2	0.0116	42.2
SNOW WATER	1.50	5430.7
MAXIMUM VEG. SOIL WATER (VOL/VOL)	0.3735	
MINIMUM VEG. SOIL WATER (VOL/VOL)	0.0570	

FINAL WATER STORAGE AT END OF YEAR 78

LAYER	(INCHES)	(VOL/VOL)
1	8.25	0.2750
2	266.61	0.3064
SNOW WATER	0.00	

BY RJP DATE 9-4-91

HART ENGINEERS, INC.

SHEET

A-7
PAGE

CHK'D _____ DATE _____

SUBJECT Cardington Road Landfill JOB NO. Prosg. 04
Moraine, Ohio
Case 2 Simulation

DEFAULT SOIL AND DESIGN DATA INPUT

Title: Cardington Road Landfill
Case 2 - Maximum cover; minimum waste

Do you want the program to initialize the soil water? No

Number of layers: 2

Layer data:

Layer 1

- (a) thickness 84" inches
- (b) layer type I-vert. perc. (1 or 2)
- (c) liner leakage fraction (only for layer type 4) — (0 to 1)
- (d) soil texture number # 7 (1 to 20)*
- (e) compacted? (only for soil textures 1 to 15) ✓ (Yes or No)
- (f) initial soil water content (not asked if program is to initialize the soil water or if layer type is 3 or 4) 0.057 vol/vol
(must be between wilting point and porosity) (actual)

Layer 2

- (a) thickness 552" inches
- (b) layer type I-vert. perc. (1 to 4)
- (c) liner leakage fraction (only for layer type 4) — (0 to 1)
- (d) soil texture number # 18 (1 to 20)*
- (e) compacted? (only for soil textures 1 to 15) — (Yes or No)
- (f) initial soil water content (not asked if program is to initialize the soil water or if layer type is 3 or 4) 0.2942 vol/vol
(must be between wilting point and porosity) (default)

Layer 3

- (a) thickness — inches
- (b) layer type N/Ap
- (c) liner leakage fraction (only for layer type 4) — (0 to 1)
- (d) soil texture number — (1 to 20)*
- (e) compacted? (only for soil textures 1 to 15) — (Yes or No)
- (f) initial soil water content (not asked if program is to initialize the soil water or if layer type is 3 or 4) — vol/vol
(must be between wilting point and porosity)

- Layer 4
- (a) _____
 - (b) _____
 - (c) _____
 - (d) _____
 - (e) _____
 - (f) _____

- Layer 5
- (a) _____
 - (b) _____
 - (c) _____
 - (d) _____
 - (e) _____
 - (f) _____

- Layer 6
- (a) _____
 - (b) _____
 - (c) _____
 - (d) _____
 - (e) _____
 - (f) _____

BY RJP DATE 9-4-91
CHK'D _____ DATE _____

HART ENGINEERS, INC.

SHEET A-8
OF _____
PAGE

SUBJECT Cardington Road Landfill JOB NO. PT055.04
Cover Integrity Study

<u>Layer 7</u>	<u>Layer 8</u>	<u>Layer 9</u>
(a) _____	(a) _____	(a) _____
(b) _____	(b) _____	(b) _____
(c) _____	(c) _____	(c) _____
(d) _____	(d) _____	(d) _____
(e) _____	(e) _____	(e) _____
(f) _____	(f) _____	(f) _____
<u>Layer 10</u>	<u>Layer 11</u>	<u>Layer 12</u>
(a) _____	(a) _____	(a) _____
(b) _____	(b) _____	(b) _____
(c) _____	(c) _____	(c) _____
(d) _____	(d) _____	(d) _____
(e) _____	(e) _____	(e) _____
(f) _____	(f) _____	(f) _____

If soil texture number of layer 1 is between 1 and 15, enter:
Type of vegetation: 4 (1 to 5)
SCS runoff curve number (optional): _____ (0 to 100)

If the soil texture number of layer 1 is between 16 and 20, enter:
SCS runoff curve number: _____ (0 to 100)

If landfill is open, enter potential runoff fraction: No (0 to 1)

Surface area: 43,560 square feet

Slope of top liner/drain system: _____ percent
Distance from crest to drain in top liner/drain system: _____ feet

Slope of second liner/drain system: _____ percent
Distance from crest to drain in second liner/drain system: _____ feet

Slope of third liner/drain system: _____ percent
Distance from crest to drain in third liner/drain system: _____ feet

Slope of fourth liner/drain system: _____ percent
Distance from crest to drain in fourth liner/drain system: _____ feet

Initial quantity of snow or ice water on surface (not asked if program is to initialize the soil water): 0.0 inches

* If soil texture number is 19:	If soil texture number is 20:
(a) wilting point _____ vol/vol	(a) wilting point _____ vol/vol
(b) field capacity _____ vol/vol	(b) field capacity _____ vol/vol
(c) porosity _____ vol/vol	(c) porosity _____ vol/vol
(d) saturated hydraulic conductivity _____ cm/sec	(d) saturated hydraulic conductivity _____ cm/sec

CARDINGTON ROAD LANDFILL
MORAINES, OHIO
SEPTEMBER 4, 1991

CASEZ

GOOD GRASS

LAYER 1

VERTICAL PERCOLATION LAYER

THICKNESS	=	84.00 INCHES
POROSITY	=	0.3808 VOL/VOL
FIELD CAPACITY	=	0.1924 VOL/VOL
WILTING POINT	=	0.1043 VOL/VOL
INITIAL SOIL WATER CONTENT	=	0.0570 VOL/VOL
SATURATED HYDRAULIC CONDUCTIVITY	=	0.000109199995 CM/SEC

LAYER 2

VERTICAL PERCOLATION LAYER

THICKNESS	=	552.00 INCHES
POROSITY	=	0.5200 VOL/VOL
FIELD CAPACITY	=	0.2942 VOL/VOL
WILTING POINT	=	0.1400 VOL/VOL
INITIAL SOIL WATER CONTENT	=	0.2942 VOL/VOL
SATURATED HYDRAULIC CONDUCTIVITY	=	0.000199999995 CM/SEC

GENERAL SIMULATION DATA

SCS RUNOFF CURVE NUMBER	=	66.43
TOTAL AREA OF COVER	=	43560. SQ FT
EVAPORATIVE ZONE DEPTH	=	21.00 INCHES

UPPER LIMIT VEG. STORAGE = 7.9968 INCHES
 INITIAL VEG. STORAGE = 1.1970 INCHES
 INITIAL SNOW WATER CONTENT = 0.0000 INCHES
 INITIAL TOTAL WATER STORAGE IN SOIL AND WASTE LAYERS = 167.1864 INCHES

SOIL WATER CONTENT INITIALIZED BY USER.

CLIMATOLOGICAL DATA

DEFAULT RAINFALL WITH SYNTHETIC DAILY TEMPERATURES AND SOLAR RADIATION FOR COLUMBUS OHIO

MAXIMUM LEAF AREA INDEX = 3.30
 START OF GROWING SEASON (JULIAN DATE) = 121
 END OF GROWING SEASON (JULIAN DATE) = 286

NORMAL MEAN MONTHLY TEMPERATURES, DEGREES FAHRENHEIT

JAN/JUL	FEB/AUG	MAR/SEP	APR/OCT	MAY/NOV	JUN/DEC
27.10	29.80	40.00	51.40	61.40	70.20
73.80	72.40	65.80	53.90	42.10	32.10

AVERAGE MONTHLY VALUES IN INCHES FOR YEARS 74 THROUGH 78

	JAN/JUL	FEB/AUG	MAR/SEP	APR/OCT	MAY/NOV	JUN/DEC
PRECIPITATION						
TOTALS	3.23	1.83	3.50	2.77	2.56	4.05
	2.67	4.76	3.16	2.48	1.96	3.12
STD. DEVIATIONS	1.60	1.20	0.91	0.93	1.41	0.69
	1.56	0.23	1.61	0.63	1.09	1.48
RUNOFF						
TOTALS	0.174	0.046	0.040	0.000	0.000	0.017
	0.007	0.045	0.015	0.014	0.003	0.014
STD. DEVIATIONS	0.388	0.103	0.063	0.000	0.000	0.028
	0.016	0.097	0.032	0.019	0.007	0.030
EVAPOTRANSPIRATION						
TOTALS	0.670	1.254	2.163	2.713	2.723	5.445
	3.107	3.742	3.567	1.845	1.284	0.666

STD. DEVIATIONS	0.205	0.295	0.299	0.776	0.895	1.271
	1.515	0.788	0.660	0.238	0.136	0.105

PERCOLATION FROM LAYER 2

TOTALS	0.1710	0.1618	0.1829	0.1793	0.1868	0.1815
	0.1875	0.1869	0.1800	0.1848	0.1776	0.1825
STD. DEVIATIONS	0.0200	0.0265	0.0400	0.0428	0.0462	0.0458
	0.0479	0.0480	0.0463	0.0475	0.0455	0.0466

AVERAGE ANNUAL TOTALS & (STD. DEVIATIONS) FOR YEARS 74 THROUGH 78

	(INCHES)	(CU. FT.)	PERCENT
PRECIPITATION	36.09 (2.628)	131021.	100.00
RUNOFF	0.374 (0.338)	1357.	1.04
EVAPOTRANSPIRATION	29.177 (1.051)	105913.	80.84
PERCOLATION FROM LAYER 2	2.1625 (0.4889)	7850.	5.99
CHANGE IN WATER STORAGE	4.380 (3.011)	15900.	12.14

PEAK DAILY VALUES FOR YEARS 74 THROUGH 78

	(INCHES)	(CU. FT.)
PRECIPITATION	2.32	8421.6
RUNOFF	0.867	3147.6
PERCOLATION FROM LAYER 2	0.0088	31.8
SNOW WATER	1.50	5430.7
MAXIMUM VEG. SOIL WATER (VOL/VOL)	0.3735	
MINIMUM VEG. SOIL WATER (VOL/VOL)	0.0570	

FINAL WATER STORAGE AT END OF YEAR 78

LAYER	(INCHES)	(VOL/VOL)
1	23.02	0.2741
2	166.07	0.3008
SNOW WATER	0.00	

BY <u>RJP</u> DATE <u>9-4-91</u>	HART ENGINEERS, INC.	SHEET OF A-13 PAGE
CHK'D _____ DATE _____	SUBJECT <u>Cardington Road Landfill</u> JOB NO. <u>PROS9.04</u>	
<u>Moraine Ohio</u>		
<u>Case 3 Simulation</u>		

DEFAULT SOIL AND DESIGN DATA INPUT

Title: Cardington Road Landfill
Case 3 - Same as Case 1 except
run for 20 yrs using simulated data

Do you want the program to initialize the soil water? No

Number of layers: 2

Layer data:

Layer 1

- (a) thickness 30" inches
- (b) layer type 1 - vert. perc. (1 or 2)
- (c) liner leakage fraction (only for layer type 4) — (0 to 1)
- (d) soil texture number #7 (1 to 20)*
- (e) compacted? (only for soil textures 1 to 15) Y (Yes or No)
- (f) initial soil water content (not asked if program is to initialize the soil water or if layer type is 3 or 4) 0.057 vol/vol
(must be between wilting point and porosity)

Layer 2

- (a) thickness 870" inches
- (b) layer type 1 - vert. perc. (1 to 4)
- (c) liner leakage fraction (only for layer type 4) — (0 to 1)
- (d) soil texture number #18 (1 to 20)*
- (e) compacted? (only for soil textures 1 to 15) — (Yes or No)
- (f) initial soil water content (not asked if program is to initialize the soil water or if layer type is 3 or 4) 0.2942 vol/vol
(must be between wilting point and porosity) (default)

Layer 3

- (a) thickness — N/A inches
- (b) layer type —
- (c) liner leakage fraction (only for layer type 4) — (0 to 1)
- (d) soil texture number — (1 to 20)*
- (e) compacted? (only for soil textures 1 to 15) — (Yes or No)
- (f) initial soil water content (not asked if program is to initialize the soil water or if layer type is 3 or 4) — vol/vol
(must be between wilting point and porosity)

Layer 4

- (a) _____
- (b) _____
- (c) _____
- (d) _____
- (e) _____
- (f) _____

Layer 5

- (a) _____
- (b) _____
- (c) _____
- (d) _____
- (e) _____
- (f) _____

Layer 6

- (a) _____
- (b) _____
- (c) _____
- (d) _____
- (e) _____
- (f) _____

BY RJP DATE 9-1-91

HART ENGINEERS, INC.

SHEET

A-14
PAGE

CHK'D _____ DATE _____

SUBJECT Cardington Road Landfill JOB NO. PT059.04
Cover Integrity Study

<u>Layer 7</u>			<u>Layer 8</u>			<u>Layer 9</u>			
(a)	_____	(a)	_____	(a)	_____	(b)	_____	(b)	_____
(b)	_____	(b)	_____	(b)	_____	(c)	_____	(c)	_____
(c)	_____	(c)	_____	(c)	_____	(d)	_____	(d)	_____
(d)	_____	(d)	_____	(d)	_____	(e)	_____	(e)	_____
(e)	_____	(e)	_____	(e)	_____	(f)	_____	(f)	_____
(f)	_____	(f)	_____	(f)	_____				
<u>Layer 10</u>			<u>Layer 11</u>			<u>Layer 12</u>			
(a)	_____	(a)	_____	(a)	_____	(b)	_____	(b)	_____
(b)	_____	(b)	_____	(b)	_____	(c)	_____	(c)	_____
(c)	_____	(c)	_____	(c)	_____	(d)	_____	(d)	_____
(d)	_____	(d)	_____	(d)	_____	(e)	_____	(e)	_____
(e)	_____	(e)	_____	(e)	_____	(f)	_____	(f)	_____
(f)	_____	(f)	_____	(f)	_____				

If soil texture number of layer 1 is between 1 and 15, enter:
Type of vegetation: 4 (1 to 5)
SCS runoff curve number (optional): _____ (0 to 100)

If the soil texture number of layer 1 is between 16 and 20, enter:
SCS runoff curve number: _____ (0 to 100)

If landfill is open, enter potential runoff fraction: No (0 to 1)

Surface area: 43,500 square feet

Slope of top liner/drain system: _____ percent
Distance from crest to drain in top liner/drain system: _____ feet

Slope of second liner/drain system: _____ percent
Distance from crest to drain in second liner/drain system: _____ feet

Slope of third liner/drain system: _____ percent
Distance from crest to drain in third liner/drain system: _____ feet

Slope of fourth liner/drain system: _____ percent
Distance from crest to drain in fourth liner/drain system: _____ feet

Initial quantity of snow or ice water on surface (not asked if
program is to initialize the soil water): 0 inches

* If soil texture number is 19:	If soil texture number is 20:
(a) wilting point _____ vol/vol	(a) wilting point _____ vol/vol
(b) field capacity _____ vol/vol	(b) field capacity _____ vol/vol
(c) porosity _____ vol/vol	(c) porosity _____ vol/vol
(d) saturated hydraulic conductivity _____ cm/sec	(d) saturated hydraulic conductivity _____ cm/sec

CARDINGTON ROAD LANDFILL
MORaine, OHIO
SEPTEMBER 4, 1991

CASE 3

GOOD GRASS

LAYER 1

VERTICAL PERCOLATION LAYER

THICKNESS	=	30.00 INCHES
POROSITY	=	0.3808 VOL/VOL
FIELD CAPACITY	=	0.1924 VOL/VOL
WILTING POINT	=	0.1043 VOL/VOL
INITIAL SOIL WATER CONTENT	=	0.0570 VOL/VOL
SATURATED HYDRAULIC CONDUCTIVITY	=	0.000109199995 CM/SEC

LAYER 2

VERTICAL PERCOLATION LAYER

THICKNESS	=	870.00 INCHES
POROSITY	=	0.5200 VOL/VOL
FIELD CAPACITY	=	0.2942 VOL/VOL
WILTING POINT	=	0.1400 VOL/VOL
INITIAL SOIL WATER CONTENT	=	0.2942 VOL/VOL
SATURATED HYDRAULIC CONDUCTIVITY	=	0.000199999995 CM/SEC

GENERAL SIMULATION DATA

SCS RUNOFF CURVE NUMBER	=	66.43
TOTAL AREA OF COVER	=	43560. SQ FT
EVAPORATIVE ZONE DEPTH	=	21.00 INCHES

UPPER LIMIT VEG. STORAGE = 7.9968 INCHES
 INITIAL VEG. STORAGE = 1.1970 INCHES
 INITIAL SNOW WATER CONTENT = 0.0000 INCHES
 INITIAL TOTAL WATER STORAGE IN
 SOIL AND WASTE LAYERS = 257.6640 INCHES

SOIL WATER CONTENT INITIALIZED BY USER.

CLIMATOLOGICAL DATA

SYNTHETIC RAINFALL WITH SYNTHETIC DAILY TEMPERATURES AND SOLAR RADIATION FOR COLUMBUS OHIO

MAXIMUM LEAF AREA INDEX = 3.30
 START OF GROWING SEASON (JULIAN DATE) = 121
 END OF GROWING SEASON (JULIAN DATE) = 286

NORMAL MEAN MONTHLY TEMPERATURES, DEGREES FAHRENHEIT

JAN/JUL	FEB/AUG	MAR/SEP	APR/OCT	MAY/NOV	JUN/DEC
26.60	29.60	39.50	51.50	61.80	71.00
74.60	73.00	66.30	54.50	42.10	31.80

MONTHLY TOTALS FOR YEAR 1

	JAN/JUL	FEB/AUG	MAR/SEP	APR/OCT	MAY/NOV	JUN/DEC
PRECIPITATION (INCHES)	1.01 2.77	1.99 3.88	2.37 3.06	2.16 0.45	3.04 4.09	4.17 2.72
RUNOFF (INCHES)	0.000 0.000	0.000 0.048	0.000 0.052	0.000 0.000	0.000 0.000	0.000 0.000
EVAPOTRANSPIRATION (INCHES)	0.513 2.787	1.478 3.727	2.112 3.113	2.931 0.450	2.486 0.667	4.706 0.707
PERCOLATION FROM LAYER 2 (INCHES)	0.1979 0.1871	0.1771 0.1853	0.1943 0.1777	0.1862 0.1820	0.1906 0.1745	0.1827 0.1787

ANNUAL TOTALS FOR YEAR 1

	(INCHES)	(CU. FT.)	PERCENT
PRECIPITATION	31.71	115107.	100.00
RUNOFF	0.100	363.	0.32
EVAPOTRANSPIRATION	25.677	93207.	80.97
PERCOLATION FROM LAYER 2	2.2141	8037.	6.98
CHANGE IN WATER STORAGE	3.719	13500.	11.73
SOIL WATER AT START OF YEAR	257.66	935320.	
SOIL WATER AT END OF YEAR	261.19	948126.	
SNOW WATER AT START OF YEAR	0.00	0.	
SNOW WATER AT END OF YEAR	0.19	694.	
ANNUAL WATER BUDGET BALANCE	0.00	0.	0.00

MONTHLY TOTALS FOR YEAR 2

	JAN/JUL	FEB/AUG	MAR/SEP	APR/OCT	MAY/NOV	JUN/DEC
PRECIPITATION (INCHES)	1.53 2.37	0.66 4.66	4.32 2.69	3.77 2.17	2.46 2.78	5.52 1.90
RUNOFF (INCHES)	0.000 0.000	0.000 0.000	0.083 0.000	0.000 0.000	0.000 0.000	0.000 0.000
EVAPOTRANSPIRATION (INCHES)	0.744 1.372	1.039 4.926	2.543 3.422	3.884 1.443	2.838 1.258	6.643 0.790
PERCOLATION FROM LAYER 2 (INCHES)	0.1776 0.2005	0.1622 0.1997	0.1844 0.1921	0.1847 0.1970	0.1971 0.1892	0.1925 0.1939

ANNUAL TOTALS FOR YEAR 2

	(INCHES)	(CU. FT.)	PERCENT
PRECIPITATION	34.83	126433.	100.00

RUNOFF	0.083	302.	0.24
EVAPOTRANSPIRATION	30.901	112172.	88.72
PERCOLATION FROM LAYER 2	2.2708	8243.	6.52
CHANGE IN WATER STORAGE	1.575	5716.	4.52
SOIL WATER AT START OF YEAR	261.19	948126.	
SOIL WATER AT END OF YEAR	262.96	954536.	
SNOW WATER AT START OF YEAR	0.19	694.	
SNOW WATER AT END OF YEAR	0.00	0.	
ANNUAL WATER BUDGET BALANCE	0.00	0.	0.00

MONTHLY TOTALS FOR YEAR 3

	JAN/JUL	FEB/AUG	MAR/SEP	APR/OCT	MAY/NOV	JUN/DEC
PRECIPITATION (INCHES)	1.88 3.66	3.39 3.84	5.37 1.91	2.49 0.77	4.75 3.70	7.59 1.94
RUNOFF (INCHES)	0.000 0.000	0.017 0.000	0.000 0.000	0.000 0.000	0.000 0.000	1.116 0.000
EVAPOTRANSPIRATION (INCHES)	0.458 5.602	0.578 3.840	3.249 1.062	2.739 1.293	4.278 0.894	6.322 0.725
PERCOLATION FROM LAYER 2 (INCHES)	0.1927 0.2626	0.1781 0.2617	0.2284 0.2511	0.2448 0.2570	0.2600 0.2461	0.2516 0.2517

ANNUAL TOTALS FOR YEAR 3

	(INCHES)	(CU. FT.)	PERCENT
PRECIPITATION	41.29	149883.	100.00
RUNOFF	1.133	4113.	2.74

EVAPOTRANSPIRATION	31.040	112674.	75.17
PERCOLATION FROM LAYER 2	2.8859	10476.	6.99
CHANGE IN WATER STORAGE	6.231	22620.	15.09
SOIL WATER AT START OF YEAR	262.96	954536.	
SOIL WATER AT END OF YEAR	268.44	974429.	
SNOW WATER AT START OF YEAR	0.00	0.	
SNOW WATER AT END OF YEAR	0.75	2727.	
ANNUAL WATER BUDGET BALANCE	0.00	0.	0.00

MONTHLY TOTALS FOR YEAR 4

	JAN/JUL	FEB/AUG	MAR/SEP	APR/OCT	MAY/NOV	JUN/DEC
PRECIPITATION (INCHES)	1.23 2.75	2.85 4.23	4.25 2.69	1.36 0.57	3.76 3.16	0.88 0.55
RUNOFF (INCHES)	0.000 0.000	0.000 0.008	0.000 0.047	0.000 0.000	0.004 0.000	0.000 0.000
EVAPOTRANSPIRATION (INCHES)	0.537 2.644	1.308 4.615	2.593 1.426	2.285 1.480	2.871 0.915	3.138 0.615
PERCOLATION FROM LAYER 2 (INCHES)	0.2526 0.2993	0.2434 0.2959	0.2801 0.2829	0.2928 0.2888	0.3039 0.2761	0.2924 0.2817

ANNUAL TOTALS FOR YEAR 4

	(INCHES)	(CU. FT.)	PERCENT
PRECIPITATION	28.28	102656.	100.00
RUNOFF	0.060	216.	0.21
EVAPOTRANSPIRATION	24.426	88668.	86.37
PERCOLATION FROM LAYER 2	3.3899	12305.	11.99

CHANGE IN WATER STORAGE	0.404	1467.	1.43
SOIL WATER AT START OF YEAR	268.44	974429.	
SOIL WATER AT END OF YEAR	269.59	978623.	
SNOW WATER AT START OF YEAR	0.75	2727.	
SNOW WATER AT END OF YEAR	0.00	0.	
ANNUAL WATER BUDGET BALANCE	0.00	0.	0.00

MONTHLY TOTALS FOR YEAR 5

	JAN/JUL	FEB/AUG	MAR/SEP	APR/OCT	MAY/NOV	JUN/DEC
PRECIPITATION (INCHES)	1.86 2.56	1.90 3.04	2.76 3.71	2.20 1.41	3.75 1.90	8.40 3.93
RUNOFF (INCHES)	0.000 0.000	0.000 0.000	0.000 0.000	0.000 0.000	0.000 0.000	0.000 0.000
EVAPOTRANSPIRATION (INCHES)	0.831 5.074	1.253 3.077	2.657 2.984	3.030 1.869	4.269 1.213	7.060 0.473
PERCOLATION FROM LAYER 2 (INCHES)	0.2782 0.2760	0.2491 0.2731	0.2767 0.2615	0.2704 0.2671	0.2797 0.2556	0.2693 0.2611

ANNUAL TOTALS FOR YEAR 5

	(INCHES)	(CU. FT.)	PERCENT
PRECIPITATION	37.42	135835.	100.00
RUNOFF	0.000	0.	0.00
EVAPOTRANSPIRATION	33.791	122661.	90.30
PERCOLATION FROM LAYER 2	3.2178	11681.	8.60
CHANGE IN WATER STORAGE	0.411	1493.	1.10

SOIL WATER AT START OF YEAR	269.59	978623.	
SOIL WATER AT END OF YEAR	269.56	978506.	
SNOW WATER AT START OF YEAR	0.00	0.	
SNOW WATER AT END OF YEAR	0.44	1610.	
ANNUAL WATER BUDGET BALANCE	0.00	0.	0.00

MONTHLY TOTALS FOR YEAR 6

	JAN/JUL	FEB/AUG	MAR/SEP	APR/OCT	MAY/NOV	JUN/DEC
PRECIPITATION (INCHES)	2.67 4.98	2.03 3.97	2.35 3.35	3.37 1.16	3.26 1.87	5.70 1.79
RUNOFF (INCHES)	0.000 0.042	0.168 0.086	0.000 0.000	0.000 0.000	0.000 0.000	0.090 0.000
EVAPOTRANSPIRATION (INCHES)	0.525 5.266	1.150 3.054	2.482 2.285	3.167 2.247	2.799 0.975	7.479 0.660
PERCOLATION FROM LAYER 2 (INCHES)	0.2661 0.3080	0.2578 0.3045	0.3078 0.2911	0.3007 0.2971	0.3121 0.2839	0.3009 0.2896

ANNUAL TOTALS FOR YEAR 6

	(INCHES)	(CU. FT.)	PERCENT
PRECIPITATION	36.50	132495.	100.00
RUNOFF	0.387	1403.	1.06
EVAPOTRANSPIRATION	32.089	116482.	87.91
PERCOLATION FROM LAYER 2	3.5194	12775.	9.64
CHANGE IN WATER STORAGE	0.505	1835.	1.38
SOIL WATER AT START OF YEAR	269.56	978506.	
SOIL WATER AT END OF YEAR	270.51	981950.	

SNOW WATER AT START OF YEAR	0.44	1610.	
SNOW WATER AT END OF YEAR	0.00	0.	
ANNUAL WATER BUDGET BALANCE	0.00	0.	0.00

MONTHLY TOTALS FOR YEAR 7

	JAN/JUL	FEB/AUG	MAR/SEP	APR/OCT	MAY/NOV	JUN/DEC
PRECIPITATION (INCHES)	4.18 1.35	0.96 4.89	2.16 2.73	3.47 6.83	1.95 1.94	5.16 1.38
RUNOFF (INCHES)	0.000 0.000	0.000 0.015	0.000 0.000	0.000 0.003	0.000 0.000	0.081 0.000
EVAPOTRANSPIRATION (INCHES)	0.511 2.083	1.121 3.450	2.985 3.329	2.864 2.194	3.177 1.469	5.356 0.784
PERCOLATION FROM LAYER 2 (INCHES)	0.2894 0.3128	0.2829 0.3090	0.3211 0.2952	0.3108 0.3039	0.3192 0.3128	0.3062 0.3289

ANNUAL TOTALS FOR YEAR 7

	(INCHES)	(CU. FT.)	PERCENT
PRECIPITATION	37.00	134310.	100.00
RUNOFF	0.099	359.	0.27
EVAPOTRANSPIRATION	29.322	106437.	79.25
PERCOLATION FROM LAYER 2	3.6923	13403.	9.98
CHANGE IN WATER STORAGE	3.887	14110.	10.51
SOIL WATER AT START OF YEAR	270.51	981950.	
SOIL WATER AT END OF YEAR	274.40	996061.	
SNOW WATER AT START OF YEAR	0.00	0.	

SNOW WATER AT END OF YEAR	0.00	0.	
ANNUAL WATER BUDGET BALANCE	0.00	0.	0.00

MONTHLY TOTALS FOR YEAR 8

	JAN/JUL	FEB/AUG	MAR/SEP	APR/OCT	MAY/NOV	JUN/DEC
PRECIPITATION (INCHES)	1.64 2.09	3.92 1.43	2.75 2.74	4.40 0.73	3.01 1.57	4.14 2.52
RUNOFF (INCHES)	0.000 0.000	0.000 0.000	0.000 0.000	0.000 0.000	0.005 0.000	0.213 0.000
EVAPOTRANSPIRATION (INCHES)	0.869 3.023	1.246 1.441	2.061 2.740	3.139 0.144	4.397 1.070	4.643 0.613
PERCOLATION FROM LAYER 2 (INCHES)	0.3313 0.3914	0.3236 0.3856	0.3721 0.3675	0.3785 0.3738	0.3978 0.3560	0.3834 0.3621

ANNUAL TOTALS FOR YEAR 8

	(INCHES)	(CU. FT.)	PERCENT
PRECIPITATION	30.94	112312.	100.00
RUNOFF	0.218	792.	0.71
EVAPOTRANSPIRATION	25.387	92153.	82.05
PERCOLATION FROM LAYER 2	4.4230	16055.	14.30
CHANGE IN WATER STORAGE	0.912	3311.	2.95
SOIL WATER AT START OF YEAR	274.40	996061.	
SOIL WATER AT END OF YEAR	275.31	999372.	
SNOW WATER AT START OF YEAR	0.00	0.	
SNOW WATER AT END OF YEAR	0.00	0.	
ANNUAL WATER BUDGET BALANCE	0.00	0.	0.00

MONTHLY TOTALS FOR YEAR 9

	JAN/JUL	FEB/AUG	MAR/SEP	APR/OCT	MAY/NOV	JUN/DEC
PRECIPITATION (INCHES)	2.50 4.03	1.86 3.07	1.77 2.36	2.79 2.09	1.72 3.34	2.79 3.63
RUNOFF (INCHES)	0.001 0.010	0.000 0.000	0.000 0.000	0.000 0.000	0.000 0.000	0.000 0.000
EVAPOTRANSPIRATION (INCHES)	0.926 4.047	1.585 3.070	2.517 1.788	2.502 1.898	1.998 1.398	4.512 0.852
PERCOLATION FROM LAYER 2 (INCHES)	0.3642 0.3571	0.3366 0.3520	0.3720 0.3357	0.3576 0.3418	0.3661 0.3260	0.3502 0.3379

ANNUAL TOTALS FOR YEAR 9

	(INCHES)	(CU. FT.)	PERCENT
PRECIPITATION	31.95	115978.	100.00
RUNOFF	0.011	39.	0.03
EVAPOTRANSPIRATION	27.092	98343.	84.79
PERCOLATION FROM LAYER 2	4.1971	15236.	13.14
CHANGE IN WATER STORAGE	0.650	2361.	2.04
SOIL WATER AT START OF YEAR	275.31	999372.	
SOIL WATER AT END OF YEAR	275.62	1000518.	
SNOW WATER AT START OF YEAR	0.00	0.	
SNOW WATER AT END OF YEAR	0.33	1215.	
ANNUAL WATER BUDGET BALANCE	0.00	0.	0.00

MONTHLY TOTALS FOR YEAR 10

	JAN/JUL	FEB/AUG	MAR/SEP	APR/OCT	MAY/NOV	JUN/DEC
PRECIPITATION (INCHES)	2.02 3.85	1.19 4.78	1.43 0.76	2.74 3.70	5.10 3.26	3.47 3.12
RUNOFF (INCHES)	0.000 0.000	0.000 0.000	0.000 0.000	0.000 0.000	0.095 0.000	0.000 0.000
EVAPOTRANSPIRATION (INCHES)	0.804 3.181	0.702 3.956	2.789 1.960	2.789 2.277	4.314 1.192	5.309 0.835
PERCOLATION FROM LAYER 2 (INCHES)	0.3527 0.3628	0.3373 0.3581	0.3755 0.3417	0.3611 0.3480	0.3695 0.3320	0.3544 0.3487

ANNUAL TOTALS FOR YEAR 10

	(INCHES)	(CU. FT.)	PERCENT
PRECIPITATION	35.42	128575.	100.00
RUNOFF	0.095	344.	0.27
EVAPOTRANSPIRATION	30.108	109290.	85.00
PERCOLATION FROM LAYER 2	4.2417	15397.	11.98
CHANGE IN WATER STORAGE	0.976	3543.	2.76
SOIL WATER AT START OF YEAR	275.62	1000518.	
SOIL WATER AT END OF YEAR	276.94	1005275.	
SNOW WATER AT START OF YEAR	0.33	1215.	
SNOW WATER AT END OF YEAR	0.00	0.	
ANNUAL WATER BUDGET BALANCE	0.00	0.	0.00

MONTHLY TOTALS FOR YEAR 11

JAN/JUL FEB/AUG MAR/SEP APR/OCT MAY/NOV JUN/DEC

PRECIPITATION (INCHES)	1.32	2.07	2.79	4.24	4.90	5.37
	2.02	1.13	3.10	2.99	2.82	3.28
RUNOFF (INCHES)	0.000	0.000	0.000	0.000	0.000	0.087
	0.000	0.000	0.003	0.000	0.000	0.000
EVAPOTRANSPIRATION (INCHES)	0.847	1.272	2.725	4.106	4.946	6.096
	3.133	0.926	3.062	1.966	1.394	0.659
PERCOLATION FROM LAYER 2 (INCHES)	0.3678	0.3452	0.3875	0.3764	0.3908	0.3766
	0.3847	0.3792	0.3614	0.3677	0.3504	0.3588

ANNUAL TOTALS FOR YEAR 11

	(INCHES)	(CU. FT.)	PERCENT
	-----	-----	-----
PRECIPITATION	36.03	130789.	100.00
RUNOFF	0.090	327.	0.25
EVAPOTRANSPIRATION	31.132	113011.	86.41
PERCOLATION FROM LAYER 2	4.4464	16141.	12.34
CHANGE IN WATER STORAGE	0.361	1311.	1.00
SOIL WATER AT START OF YEAR	276.94	1005275.	
SOIL WATER AT END OF YEAR	277.30	1006586.	
SNOW WATER AT START OF YEAR	0.00	0.	
SNOW WATER AT END OF YEAR	0.00	0.	
ANNUAL WATER BUDGET BALANCE	0.00	0.	0.00

MONTHLY TOTALS FOR YEAR 12

	JAN/JUL	FEB/AUG	MAR/SEP	APR/OCT	MAY/NOV	JUN/DEC
PRECIPITATION (INCHES)	5.46 2.38	3.08 1.50	3.94 2.73	1.97 2.41	1.23 3.30	4.72 1.77
RUNOFF (INCHES)	0.000 0.000	0.000 0.000	0.310 0.000	0.000 0.000	0.000 0.000	0.000 0.000
EVAPOTRANSPIRATION (INCHES)	0.549 3.333	0.692 1.500	3.068 2.730	2.266 0.985	1.990 1.258	4.807 0.746
PERCOLATION FROM LAYER 2 (INCHES)	0.3810 0.5093	0.3929 0.4989	0.5027 0.4730	0.5149 0.4789	0.5275 0.4541	0.5024 0.4610

ANNUAL TOTALS FOR YEAR 12

	(INCHES)	(CU. FT.)	PERCENT
PRECIPITATION	34.49	125199.	100.00
RUNOFF	0.310	1125.	0.90
EVAPOTRANSPIRATION	23.924	86845.	69.37
PERCOLATION FROM LAYER 2	5.6966	20679.	16.52
CHANGE IN WATER STORAGE	4.559	16551.	13.22
SOIL WATER AT START OF YEAR	277.30	1006586.	
SOIL WATER AT END OF YEAR	281.86	1023136.	
SNOW WATER AT START OF YEAR	0.00	0.	
SNOW WATER AT END OF YEAR	0.00	0.	
ANNUAL WATER BUDGET BALANCE	0.00	0.	0.00

MONTHLY TOTALS FOR YEAR 13

	JAN/JUL	FEB/AUG	MAR/SEP	APR/OCT	MAY/NOV	JUN/DEC
PRECIPITATION (INCHES)	1.68 3.08	1.53 1.64	4.81 2.14	1.26 1.61	3.53 3.08	2.91 2.44
RUNOFF (INCHES)	0.000 0.000	0.000 0.000	0.000 0.000	0.000 0.000	0.000 0.000	0.000 0.000
EVAPOTRANSPIRATION (INCHES)	1.081 3.074	0.809 2.229	2.843 2.187	1.921 1.059	3.296 1.106	4.310 0.904
PERCOLATION FROM LAYER 2 (INCHES)	0.4654 0.4960	0.4282 0.4868	0.4832 0.4620	0.4901 0.4681	0.5083 0.4442	0.4872 0.4518

ANNUAL TOTALS FOR YEAR 13

	(INCHES)	(CU. FT.)	PERCENT
PRECIPITATION	29.71	107847.	100.00
RUNOFF	0.000	0.	0.00
EVAPOTRANSPIRATION	24.818	90090.	83.53
PERCOLATION FROM LAYER 2	5.6714	20587.	19.09
CHANGE IN WATER STORAGE	-0.780	-2830.	-2.62
SOIL WATER AT START OF YEAR	281.86	1023136.	
SOIL WATER AT END OF YEAR	281.08	1020306.	
SNOW WATER AT START OF YEAR	0.00	0.	
SNOW WATER AT END OF YEAR	0.00	0.	
ANNUAL WATER BUDGET BALANCE	0.00	0.	0.00

MONTHLY TOTALS FOR YEAR 14

JAN/JUL FEB/AUG MAR/SEP APR/OCT MAY/NOV JUN/DEC

PRECIPITATION (INCHES)	3.47	3.11	3.41	6.64	4.28	5.90
	3.55	1.88	2.60	2.32	4.27	3.74
RUNOFF (INCHES)	0.010	0.000	0.000	0.047	0.000	0.111
	0.000	0.000	0.000	0.000	0.000	0.000
EVAPOTRANSPIRATION (INCHES)	0.867	1.214	2.364	3.287	4.882	6.302
	2.933	2.472	2.344	1.965	1.088	0.722
PERCOLATION FROM LAYER 2 (INCHES)	0.4572	0.4495	0.5430	0.5968	0.6454	0.6205
	0.6342	0.6197	0.5854	0.5903	0.5575	0.5866

ANNUAL TOTALS FOR YEAR 14

	(INCHES)	(CU. FT.)	PERCENT
PRECIPITATION	45.17	163967.	100.00
RUNOFF	0.168	608.	0.37
EVAPOTRANSPIRATION	30.441	110499.	67.39
PERCOLATION FROM LAYER 2	6.8860	24996.	15.24
CHANGE IN WATER STORAGE	7.676	27863.	16.99
SOIL WATER AT START OF YEAR	281.08	1020306.	
SOIL WATER AT END OF YEAR	288.75	1048169.	
SNOW WATER AT START OF YEAR	0.00	0.	
SNOW WATER AT END OF YEAR	0.00	0.	
ANNUAL WATER BUDGET BALANCE	0.00	0.	0.00

MONTHLY TOTALS FOR YEAR 15

	JAN/JUL	FEB/AUG	MAR/SEP	APR/OCT	MAY/NOV	JUN/DEC
PRECIPITATION (INCHES)	2.70	2.50	2.69	3.77	1.53	4.53
	2.66	2.95	2.20	0.70	4.62	2.92

RUNOFF (INCHES)	0.000	0.024	0.000	0.000	0.000	0.000
	0.000	0.075	0.000	0.000	0.000	0.000
EVAPOTRANSPIRATION (INCHES)	0.730	1.279	2.760	3.320	2.994	3.436
	4.328	2.708	2.394	0.770	0.821	0.810
PERCOLATION FROM LAYER 2 (INCHES)	0.6364	0.5838	0.6936	0.6771	0.6891	0.6522
	0.6571	0.6399	0.6034	0.6076	0.5732	0.6083

ANNUAL TOTALS FOR YEAR 15

	(INCHES)	(CU. FT.)	PERCENT
PRECIPITATION	33.77	122585.	100.00
RUNOFF	0.099	359.	0.29
EVAPOTRANSPIRATION	26.348	95645.	78.02
PERCOLATION FROM LAYER 2	7.6215	27666.	22.57
CHANGE IN WATER STORAGE	-0.299	-1085.	-0.88
SOIL WATER AT START OF YEAR	288.75	1048169.	
SOIL WATER AT END OF YEAR	288.45	1047085.	
SNOW WATER AT START OF YEAR	0.00	0.	
SNOW WATER AT END OF YEAR	0.00	0.	
ANNUAL WATER BUDGET BALANCE	0.00	0.	0.00

MONTHLY TOTALS FOR YEAR 16

	JAN/JUL	FEB/AUG	MAR/SEP	APR/OCT	MAY/NOV	JUN/DEC
PRECIPITATION (INCHES)	1.42	1.17	4.34	6.54	5.03	1.27
	3.68	0.82	0.42	2.53	3.08	2.19
RUNOFF (INCHES)	0.000	0.000	0.086	0.041	0.000	0.000
	0.066	0.000	0.000	0.000	0.000	0.000

EVAPOTRANSPIRATION (INCHES)	0.724 3.581	1.492 0.867	2.439 0.420	4.182 1.813	4.722 1.046	3.632 0.919
PERCOLATION FROM LAYER 2 (INCHES)	0.6321 0.6870	0.5958 0.6690	0.6296 0.6304	0.6229 0.6343	0.7002 0.5979	0.6800 0.6056

ANNUAL TOTALS FOR YEAR 16

	(INCHES)	(CU. FT.)	PERCENT
PRECIPITATION	32.49	117939.	100.00
RUNOFF	0.194	703.	0.60
EVAPOTRANSPIRATION	25.837	93788.	79.52
PERCOLATION FROM LAYER 2	7.6848	27896.	23.65
CHANGE IN WATER STORAGE	-1.225	-4448.	-3.77
SOIL WATER AT START OF YEAR	288.45	1047085.	
SOIL WATER AT END OF YEAR	287.23	1042637.	
SNOW WATER AT START OF YEAR	0.00	0.	
SNOW WATER AT END OF YEAR	0.00	0.	
ANNUAL WATER BUDGET BALANCE	0.00	0.	0.00

MONTHLY TOTALS FOR YEAR 17

	JAN/JUL	FEB/AUG	MAR/SEP	APR/OCT	MAY/NOV	JUN/DEC
PRECIPITATION (INCHES)	0.54 4.63	1.35 4.91	3.42 3.84	2.66 1.07	4.22 2.54	6.08 2.39
RUNOFF (INCHES)	0.000 0.053	0.000 0.079	0.000 0.000	0.000 0.000	0.000 0.000	0.094 0.000
EVAPOTRANSPIRATION (INCHES)	1.038 4.242	1.362 4.361	2.690 3.568	2.218 2.082	5.666 1.010	6.820 0.828

PERCOLATION FROM	0.6071	0.5422	0.5900	0.5598	0.5676	0.5387
LAYER 2 (INCHES)	0.5451	0.5331	0.5047	0.5103	0.4833	0.4889

ANNUAL TOTALS FOR YEAR 17

	(INCHES)	(CU. FT.)	PERCENT
PRECIPITATION	37.65	136669.	100.00
RUNOFF	0.227	822.	0.60
EVAPOTRANSPIRATION	35.885	130261.	95.31
PERCOLATION FROM LAYER 2	6.4707	23489.	17.19
CHANGE IN WATER STORAGE	-4.932	-17903.	-13.10
SOIL WATER AT START OF YEAR	287.23	1042637.	
SOIL WATER AT END OF YEAR	282.28	1024691.	
SNOW WATER AT START OF YEAR	0.00	0.	
SNOW WATER AT END OF YEAR	0.01	43.	
ANNUAL WATER BUDGET BALANCE	0.00	0.	0.00

MONTHLY TOTALS FOR YEAR 18

	JAN/JUL	FEB/AUG	MAR/SEP	APR/OCT	MAY/NOV	JUN/DEC
PRECIPITATION (INCHES)	2.07 5.17	1.68 5.84	1.03 1.24	2.79 0.96	4.09 3.31	4.32 2.45
RUNOFF (INCHES)	0.000 0.000	0.000 0.000	0.000 0.000	0.000 0.000	0.000 0.000	0.000 0.000
EVAPOTRANSPIRATION (INCHES)	0.747 5.647	1.420 6.047	2.013 1.928	2.754 0.225	3.908 0.989	4.775 0.719
PERCOLATION FROM LAYER 2 (INCHES)	0.4837 0.4694	0.4447 0.4606	0.4929 0.4374	0.4747 0.4435	0.4851 0.4211	0.4624 0.4287

ANNUAL TOTALS FOR YEAR 18

	(INCHES)	(CU. FT.)	PERCENT
PRECIPITATION	34.95	126868.	100.00
RUNOFF	0.000	0.	0.00
EVAPOTRANSPIRATION	31.171	113149.	89.19
PERCOLATION FROM LAYER 2	5.5043	19980.	15.75
CHANGE IN WATER STORAGE	-1.725	-6261.	-4.94
SOIL WATER AT START OF YEAR	282.28	1024691.	
SOIL WATER AT END OF YEAR	280.57	1018473.	
SNOW WATER AT START OF YEAR	0.01	43.	
SNOW WATER AT END OF YEAR	0.00	0.	
ANNUAL WATER BUDGET BALANCE	0.00	0.	0.00

MONTHLY TOTALS FOR YEAR 19

	JAN/JUL	FEB/AUG	MAR/SEP	APR/OCT	MAY/NOV	JUN/DEC
PRECIPITATION (INCHES)	2.98 1.41	1.70 4.70	3.23 0.38	2.60 2.41	3.99 3.92	6.65 3.28
RUNOFF (INCHES)	0.000 0.000	0.000 0.000	0.008 0.000	0.000 0.000	0.000 0.000	0.000 0.000
EVAPOTRANSPIRATION (INCHES)	0.432 1.860	1.341 3.324	2.938 1.756	3.380 1.601	3.619 1.353	7.875 0.808
PERCOLATION FROM LAYER 2 (INCHES)	0.4402 0.4784	0.4324 0.4692	0.5064 0.4453	0.4867 0.4513	0.4957 0.4284	0.4716 0.4371

ANNUAL TOTALS FOR YEAR 19

	(INCHES)	(CU. FT.)	PERCENT
PRECIPITATION	37.25	135218.	100.00
RUNOFF	0.008	30.	0.02
EVAPOTRANSPIRATION	30.285	109935.	81.30
PERCOLATION FROM LAYER 2	5.5428	20120.	14.88
CHANGE IN WATER STORAGE	1.414	5133.	3.80
SOIL WATER AT START OF YEAR	280.57	1018473.	
SOIL WATER AT END OF YEAR	281.99	1023606.	
SNOW WATER AT START OF YEAR	0.00	0.	
SNOW WATER AT END OF YEAR	0.00	0.	
ANNUAL WATER BUDGET BALANCE	0.00	0.	0.00

MONTHLY TOTALS FOR YEAR 20

	JAN/JUL	FEB/AUG	MAR/SEP	APR/OCT	MAY/NOV	JUN/DEC
PRECIPITATION (INCHES)	2.99 2.90	2.76 2.42	3.02 4.15	1.81 3.59	4.56 3.42	2.23 0.93
RUNOFF (INCHES)	0.000 0.000	0.000 0.000	0.000 0.072	0.000 0.000	0.019 0.000	0.000 0.000
EVAPOTRANSPIRATION (INCHES)	0.836 3.505	1.353 2.420	2.999 3.098	2.091 2.134	3.487 0.993	4.173 0.862
PERCOLATION FROM LAYER 2 (INCHES)	0.4695 0.5187	0.4794 0.5089	0.5361 0.4828	0.5168 0.4888	0.5267 0.4637	0.5074 0.4913

ANNUAL TOTALS FOR YEAR 20

	(INCHES)	(CU. FT.)	PERCENT
PRECIPITATION	34.78	126251.	100.00
RUNOFF	0.091	329.	0.26
EVAPOTRANSPIRATION	27.951	101462.	80.37
PERCOLATION FROM LAYER 2	5.9901	21744.	17.22
CHANGE IN WATER STORAGE	0.748	2717.	2.15
SOIL WATER AT START OF YEAR	281.99	1023606.	
SOIL WATER AT END OF YEAR	282.73	1026323.	
SNOW WATER AT START OF YEAR	0.00	0.	
SNOW WATER AT END OF YEAR	0.00	0.	
ANNUAL WATER BUDGET BALANCE	0.00	0.	0.00

AVERAGE MONTHLY VALUES IN INCHES FOR YEARS 1 THROUGH 20

	JAN/JUL	FEB/AUG	MAR/SEP	APR/OCT	MAY/NOV	JUN/DEC
PRECIPITATION						
TOTALS	2.26 3.09	2.09 3.28	3.11 2.44	3.15 2.02	3.51 3.10	4.59 2.44
STD. DEVIATIONS	1.16 1.08	0.87 1.50	1.14 1.07	1.46 1.50	1.20 0.83	1.96 0.92
RUNOFF						
TOTALS	0.001 0.009	0.010 0.016	0.024 0.009	0.004 0.000	0.006 0.000	0.090 0.000
STD. DEVIATIONS	0.002 0.020	0.038 0.030	0.072 0.021	0.014 0.001	0.021 0.000	0.249 0.000
EVAPOTRANSPIRATION						
TOTALS	0.728 3.536	1.185 3.100	2.641 2.380	2.943 1.495	3.647 1.105	5.370 0.751

STD. DEVIATIONS	0.193	0.284	0.337	0.641	1.023	1.382
	1.205	1.348	0.833	0.682	0.210	0.111

PERCOLATION FROM LAYER 2

TOTALS	0.3822	0.3621	0.4139	0.4102	0.4266	0.4091
	0.4169	0.4095	0.3891	0.3949	0.3763	0.3876
STD. DEVIATIONS	0.1408	0.1317	0.1473	0.1457	0.1544	0.1472
	0.1476	0.1426	0.1333	0.1330	0.1237	0.1289

AVERAGE ANNUAL TOTALS & (STD. DEVIATIONS) FOR YEARS 1 THROUGH 20

	(INCHES)	(CU. FT.)	PERCENT
PRECIPITATION	35.08 (3.881)	127346.	100.00
RUNOFF	0.169 (0.250)	612.	0.48
EVAPOTRANSPIRATION	28.881 (3.338)	104839.	82.33
PERCOLATION FROM LAYER 2	4.7783 (1.6621)	17345.	13.62
CHANGE IN WATER STORAGE	1.253 (2.842)	4550.	3.57

PEAK DAILY VALUES FOR YEARS 1 THROUGH 20

	(INCHES)	(CU. FT.)
PRECIPITATION	2.48	9002.4
RUNOFF	1.103	4004.8
PERCOLATION FROM LAYER 2	0.0228	82.9
SNOW WATER	3.02	10965.2
MAXIMUM VEG. SOIL WATER (VOL/VOL)	0.3630	
MINIMUM VEG. SOIL WATER (VOL/VOL)	0.0570	

FINAL WATER STORAGE AT END OF YEAR 20

LAYER	(INCHES)	(VOL/VOL)
1	7.58	0.2527
2	275.15	0.3163
SNOW WATER	0.00	

SUBJECT Cardington Road Landfill JOB NO. PT059.04
Moraine, Ohio
Case 4 Simulation

DEFAULT SOIL AND DESIGN DATA INPUT

Title: Cardington Road Landfill
Case 4: Same as Case 2 except
run for 20 yrs using simulated data

Do you want the program to initialize the soil water? No

Number of layers: 2

Layer data:

Layer 1

- (a) thickness 84" inches
- (b) layer type 1-vert. perc. (1 or 2)
- (c) liner leakage fraction (only for layer type 4) — (0 to 1)
- (d) soil texture number #7 (1 to 20)*
- (e) compacted? (only for soil textures 1 to 15) Y (Yes or No)
- (f) initial soil water content (not asked if program is to initialize the soil water or if layer type is 3 or 4) 0.057 vol/vol
 (must be between wilting point and porosity) (actual)

Layer 2

- (a) thickness 552" inches
- (b) layer type 1-vert. perc. (1 to 4)
- (c) liner leakage fraction (only for layer type 4) — (0 to 1)
- (d) soil texture number #18 (1 to 20)*
- (e) compacted? (only for soil textures 1 to 15) — (Yes or No)
- (f) initial soil water content (not asked if program is to initialize the soil water or if layer type is 3 or 4) 0.2943 vol/vol
 (must be between wilting point and porosity) (default)

Layer 3

- (a) thickness — N/Ap inches
- (b) layer type —
- (c) liner leakage fraction (only for layer type 4) — (0 to 1)
- (d) soil texture number — (1 to 20)*
- (e) compacted? (only for soil textures 1 to 15) — (Yes or No)
- (f) initial soil water content (not asked if program is to initialize the soil water or if layer type is 3 or 4) — vol/vol
 (must be between wilting point and porosity)

Layer 4

- (a) _____
- (b) _____
- (c) _____
- (d) _____
- (e) _____
- (f) _____

Layer 5

- (a) _____
- (b) _____
- (c) _____
- (d) _____
- (e) _____
- (f) _____

Layer 6

- (a) _____
- (b) _____
- (c) _____
- (d) _____
- (e) _____
- (f) _____

BY RJP DATE 9-4-91

HART ENGINEERS, INC.

SHEET

A-39
PAGE

CHK'D _____ DATE _____

SUBJECT Cardington Road Landfill JOB NO. PT059.04
Cover Integrity Study

<u>Layer 7</u> (a) _____ (b) _____ (c) _____ (d) _____ (e) _____ (f) _____	<u>Layer 8</u> (a) _____ (b) _____ (c) _____ (d) _____ (e) _____ (f) _____	<u>Layer 9</u> (a) _____ (b) _____ (c) _____ (d) _____ (e) _____ (f) _____
<u>Layer 10</u> (a) _____ (b) _____ (c) _____ (d) _____ (e) _____ (f) _____	<u>Layer 11</u> (a) _____ (b) _____ (c) _____ (d) _____ (e) _____ (f) _____	<u>Layer 12</u> (a) _____ (b) _____ (c) _____ (d) _____ (e) _____ (f) _____

If soil texture number of layer 1 is between 1 and 15, enter:
 Type of vegetation: 4 (1 to 5)
 SCS runoff curve number (optional): _____ (0 to 100)

If the soil texture number of layer 1 is between 16 and 20, enter:
 SCS runoff curve number: _____ (0 to 100)

If landfill is open, enter potential runoff fraction: _____ (0 to 1)

Surface area: 43,560 square feet

Slope of top liner/drain system: _____ percent
 Distance from crest to drain in top liner/drain system: _____ feet

Slope of second liner/drain system: _____ percent
 Distance from crest to drain in second liner/drain system: _____ feet

Slope of third liner/drain system: _____ percent
 Distance from crest to drain in third liner/drain system: _____ feet

Slope of fourth liner/drain system: _____ percent
 Distance from crest to drain in fourth liner/drain system: _____ feet

Initial quantity of snow or ice water on surface (not asked if program is to initialize the soil water): 0 inches

* If soil texture number is 19:	If soil texture number is 20:
(a) wilting point _____ vol/vol	(a) wilting point _____ vol/vol
(b) field capacity _____ vol/vol	(b) field capacity _____ vol/vol
(c) porosity _____ vol/vol	(c) porosity _____ vol/vol
(d) saturated hydraulic conductivity _____ cm/sec	(d) saturated hydraulic conductivity _____ cm/sec

CARDINGTON ROAD LANDFILL
MORaine, OHIO
SEPTEMBER 4, 1991

CASE 4

GOOD GRASS

LAYER 1

VERTICAL PERCOLATION LAYER

THICKNESS	=	84.00 INCHES
POROSITY	=	0.3808 VOL/VOL
FIELD CAPACITY	=	0.1924 VOL/VOL
WILTING POINT	=	0.1043 VOL/VOL
INITIAL SOIL WATER CONTENT	=	0.0570 VOL/VOL
SATURATED HYDRAULIC CONDUCTIVITY	=	0.000109199995 CM/SEC

LAYER 2

VERTICAL PERCOLATION LAYER

THICKNESS	=	552.00 INCHES
POROSITY	=	0.5200 VOL/VOL
FIELD CAPACITY	=	0.2942 VOL/VOL
WILTING POINT	=	0.1400 VOL/VOL
INITIAL SOIL WATER CONTENT	=	0.2942 VOL/VOL
SATURATED HYDRAULIC CONDUCTIVITY	=	0.000199999995 CM/SEC

GENERAL SIMULATION DATA

SCS RUNOFF CURVE NUMBER	=	66.43
TOTAL AREA OF COVER	=	43560. SQ FT
EVAPORATIVE ZONE DEPTH	=	21.00 INCHES

UPPER LIMIT VEG. STORAGE = 7.9968 INCHES
 INITIAL VEG. STORAGE = 1.1970 INCHES
 INITIAL SNOW WATER CONTENT = 0.0000 INCHES
 INITIAL TOTAL WATER STORAGE IN SOIL AND WASTE LAYERS = 167.1864 INCHES

SOIL WATER CONTENT INITIALIZED BY USER.

CLIMATOLOGICAL DATA

SYNTHETIC RAINFALL WITH SYNTHETIC DAILY TEMPERATURES AND SOLAR RADIATION FOR COLUMBUS OHIO

MAXIMUM LEAF AREA INDEX = 3.30
 START OF GROWING SEASON (JULIAN DATE) = 121
 END OF GROWING SEASON (JULIAN DATE) = 286

NORMAL MEAN MONTHLY TEMPERATURES, DEGREES FAHRENHEIT

JAN/JUL	FEB/AUG	MAR/SEP	APR/OCT	MAY/NOV	JUN/DEC
26.60	29.60	39.50	51.50	61.80	71.00
74.60	73.00	66.30	54.50	42.10	31.80

AVERAGE MONTHLY VALUES IN INCHES FOR YEARS 1 THROUGH 20

	JAN/JUL	FEB/AUG	MAR/SEP	APR/OCT	MAY/NOV	JUN/DEC
PRECIPITATION						
TOTALS	2.26 3.09	2.09 3.28	3.11 2.44	3.15 2.02	3.51 3.10	4.59 2.44
STD. DEVIATIONS	1.16 1.08	0.87 1.50	1.14 1.07	1.46 1.50	1.20 0.83	1.96 0.92
RUNOFF						
TOTALS	0.001 0.009	0.010 0.016	0.024 0.009	0.004 0.000	0.006 0.000	0.089 0.000
STD. DEVIATIONS	0.002 0.020	0.038 0.030	0.072 0.021	0.014 0.001	0.021 0.000	0.248 0.000
EVAPOTRANSPIRATION						
TOTALS	0.728 3.536	1.185 3.100	2.641 2.380	2.942 1.495	3.645 1.105	5.372 0.751

STD. DEVIATIONS	0.193	0.284	0.337	0.641	1.022	1.383
	1.205	1.348	0.833	0.681	0.210	0.111

PERCOLATION FROM LAYER 2

TOTALS	0.3559	0.3301	0.3780	0.3810	0.4043	0.3935
	0.4040	0.3984	0.3788	0.3838	0.3641	0.3701

STD. DEVIATIONS	0.1727	0.1601	0.1830	0.1871	0.2034	0.1990
	0.2027	0.1970	0.1840	0.1830	0.1699	0.1697

AVERAGE ANNUAL TOTALS & (STD. DEVIATIONS) FOR YEARS 1 THROUGH 20

	(INCHES)	(CU. FT.)	PERCENT
PRECIPITATION	35.08 (3.881)	127346.	100.00
RUNOFF	0.168 (0.250)	611.	0.48
EVAPOTRANSPIRATION	28.880 (3.338)	104835.	82.32
PERCOLATION FROM LAYER 2	4.5420 (2.1872)	16487.	12.95
CHANGE IN WATER STORAGE	1.491 (2.954)	5412.	4.25

PEAK DAILY VALUES FOR YEARS 1 THROUGH 20

	(INCHES)	(CU. FT.)
PRECIPITATION	2.48	9002.4
RUNOFF	1.101	3996.4
PERCOLATION FROM LAYER 2	0.0255	92.5
SNOW WATER	3.02	10965.6
MAXIMUM VEG. SOIL WATER (VOL/VOL)	0.3630	
MINIMUM VEG. SOIL WATER (VOL/VOL)	0.0570	

FINAL WATER STORAGE AT END OF YEAR 20

LAYER	(INCHES)	(VOL/VOL)
1	23.01	0.2739
2	174.00	0.3152
SNOW WATER	0.00	

SUBJECT Cardington Road Landfill JOB NO. _____
Marietta, Ohio
Case 5 Simulation

DEFAULT SOIL AND DESIGN DATA INPUT

Title: Cardington Road Landfill
Case 5 - Same as Case 3 except
for waste $K = 1 \times 10^{-5}$ cm/sec

Do you want the program to initialize the soil water? No

Number of layers: 2

Layer data:

Layer 1
 (a) thickness 30" inches
 (b) layer type 1 - vert. per. (1 or 2)
 (c) liner leakage fraction (only for layer type 4) — (0 to 1)
 (d) soil texture number #7 (1 to 20)*
 (e) compacted? (only for soil textures 1 to 15) Y (Yes or No)
 (f) initial soil water content (not asked if program is to initialize
 the soil water or if layer type is 3 or 4) 0.057 vol/vol
 (must be between wilting point and porosity) (actual)

Layer 2
 (a) thickness 870" inches
 (b) layer type 1 - vert. per. (1 to 4)
 (c) liner leakage fraction (only for layer type 4) — (0 to 1)
 (d) soil texture number #10 (1 to 20)*
 (e) compacted? (only for soil textures 1 to 15) — (Yes or No)
 (f) initial soil water content (not asked if program is to initialize
 the soil water or if layer type is 3 or 4) 0.2942 vol/vol
 (must be between wilting point and porosity) (default)

Layer 3
 (a) thickness — inches
 (b) layer type N/A
 (c) liner leakage fraction (only for layer type 4) — (0 to 1)
 (d) soil texture number — (1 to 20)*
 (e) compacted? (only for soil textures 1 to 15) — (Yes or No)
 (f) initial soil water content (not asked if program is to initialize
 the soil water or if layer type is 3 or 4) — vol/vol
 (must be between wilting point and porosity)

<u>Layer 4</u>	<u>Layer 5</u>	<u>Layer 6</u>
(a) _____	(a) _____	(a) _____
(b) _____	(b) _____	(b) _____
(c) _____	(c) _____	(c) _____
(d) _____	(d) _____	(d) _____
(e) _____	(e) _____	(e) _____
(f) _____	(f) _____	(f) _____

BY RJP DATE 9-4-91

HART ENGINEERS, INC.

SHEET

A-45

CNK'D _____ DATE _____

OF _____

PAGE

SUBJECT Cardington Road Landfill JOB NO. PT059.04
Cover Integrity Study

<u>Layer 7</u> (a) _____ (b) _____ (c) _____ (d) _____ (e) _____ (f) _____	<u>Layer 8</u> (a) _____ (b) _____ (c) _____ (d) _____ (e) _____ (f) _____	<u>Layer 9</u> (a) _____ (b) _____ (c) _____ (d) _____ (e) _____ (f) _____
<u>Layer 10</u> (a) _____ (b) _____ (c) _____ (d) _____ (e) _____ (f) _____	<u>Layer 11</u> (a) _____ (b) _____ (c) _____ (d) _____ (e) _____ (f) _____	<u>Layer 12</u> (a) _____ (b) _____ (c) _____ (d) _____ (e) _____ (f) _____

If soil texture number of layer 1 is between 1 and 15, enter:
Type of vegetation: 4 (1 to 5)
SCS runoff curve number (optional): _____ (0 to 100)

If the soil texture number of layer 1 is between 16 and 20, enter:
SCS runoff curve number: _____ (0 to 100)

If landfill is open, enter potential runoff fraction: No (0 to 1)

Surface area: 43,560 square feet

Slope of top liner/drain system: _____ percent
Distance from crest to drain in top liner/drain system: _____ feet

Slope of second liner/drain system: _____ percent
Distance from crest to drain in second liner/drain system: _____ feet

Slope of third liner/drain system: _____ percent
Distance from crest to drain in third liner/drain system: _____ feet

Slope of fourth liner/drain system: _____ percent
Distance from crest to drain in fourth liner/drain system: _____ feet

Initial quantity of snow or ice water on surface (not asked if program is to initialize the soil water): 0.0 inches

* If soil texture number is 19:	If soil texture number is 20:
(a) wilting point _____ vol/vol	(a) wilting point _____ vol/vol
(b) field capacity _____ vol/vol	(b) field capacity _____ vol/vol
(c) porosity _____ vol/vol	(c) porosity _____ vol/vol
(d) saturated hydraulic conductivity _____ cm/sec	(d) saturated hydraulic conductivity _____ cm/sec

CARDINGTON ROAD LANDFILL
MORaine, OHIO
SEPTEMBER 4, 1991

CASE 5

GOOD GRASS

LAYER 1

VERTICAL PERCOLATION LAYER

THICKNESS	=	30.00 INCHES
POROSITY	=	0.3808 VOL/VOL
FIELD CAPACITY	=	0.1924 VOL/VOL
WILTING POINT	=	0.1043 VOL/VOL
INITIAL SOIL WATER CONTENT	=	0.0570 VOL/VOL
SATURATED HYDRAULIC CONDUCTIVITY	=	0.000109200002 CM/SEC

LAYER 2

VERTICAL PERCOLATION LAYER

THICKNESS	=	870.00 INCHES
POROSITY	=	0.5200 VOL/VOL
FIELD CAPACITY	=	0.2942 VOL/VOL
WILTING POINT	=	0.1400 VOL/VOL
INITIAL SOIL WATER CONTENT	=	0.2942 VOL/VOL
SATURATED HYDRAULIC CONDUCTIVITY	=	0.000010000000 CM/SEC

GENERAL SIMULATION DATA

SCS RUNOFF CURVE NUMBER	=	66.43
TOTAL AREA OF COVER	=	43560. SQ FT
EVAPORATIVE ZONE DEPTH	=	21.00 INCHES

UPPER LIMIT VEG. STORAGE = 7.9968 INCHES
 INITIAL VEG. STORAGE = 1.1970 INCHES
 INITIAL SNOW WATER CONTENT = 0.0000 INCHES
 INITIAL TOTAL WATER STORAGE IN SOIL AND WASTE LAYERS = 257.6640 INCHES

SOIL WATER CONTENT INITIALIZED BY USER.

CLIMATOLOGICAL DATA

SYNTHETIC RAINFALL WITH SYNTHETIC DAILY TEMPERATURES AND SOLAR RADIATION FOR COLUMBUS OHIO

MAXIMUM LEAF AREA INDEX = 3.30
 START OF GROWING SEASON (JULIAN DATE) = 121
 END OF GROWING SEASON (JULIAN DATE) = 286

NORMAL MEAN MONTHLY TEMPERATURES, DEGREES FAHRENHEIT

JAN/JUL	FEB/AUG	MAR/SEP	APR/OCT	MAY/NOV	JUN/DEC
26.60	29.60	39.50	51.50	61.80	71.00
74.60	73.00	66.30	54.50	42.10	31.80

AVERAGE MONTHLY VALUES IN INCHES FOR YEARS 1 THROUGH 20

	JAN/JUL	FEB/AUG	MAR/SEP	APR/OCT	MAY/NOV	JUN/DEC
PRECIPITATION						
TOTALS	2.26 3.09	2.09 3.28	3.11 2.44	3.15 2.02	3.51 3.10	4.59 2.44
STD. DEVIATIONS	1.16 1.08	0.87 1.50	1.14 1.07	1.46 1.50	1.20 0.83	1.96 0.92
RUNOFF						
TOTALS	0.001 0.009	0.010 0.016	0.024 0.009	0.004 0.000	0.006 0.000	0.090 0.000
STD. DEVIATIONS	0.002 0.020	0.038 0.030	0.072 0.021	0.014 0.001	0.021 0.000	0.249 0.000
EVAPOTRANSPIRATION						
TOTALS	0.728 3.536	1.185 3.100	2.641 2.380	2.943 1.495	3.647 1.105	5.370 0.751

STD. DEVIATIONS	0.193	0.284	0.337	0.641	1.023	1.382
	1.205	1.348	0.833	0.682	0.210	0.111

PERCOLATION FROM LAYER 2

TOTALS	0.1167	0.1113	0.1268	0.1257	0.1319	0.1279
	0.1318	0.1311	0.1260	0.1293	0.1243	0.1294
STD. DEVIATIONS	0.1117	0.1064	0.1193	0.1163	0.1215	0.1176
	0.1208	0.1197	0.1147	0.1173	0.1122	0.1168

AVERAGE ANNUAL TOTALS & (STD. DEVIATIONS) FOR YEARS 1 THROUGH 20

	(INCHES)	(CU. FT.)	PERCENT
PRECIPITATION	35.08 (3.881)	127346.	100.00
RUNOFF	0.169 (0.250)	612.	0.48
EVAPOTRANSPIRATION	28.881 (3.338)	104839.	82.33
PERCOLATION FROM LAYER 2	1.5122 (1.3924)	5489.	4.31
CHANGE IN WATER STORAGE	4.520 (3.061)	16406.	12.88

PEAK DAILY VALUES FOR YEARS 1 THROUGH 20

	(INCHES)	(CU. FT.)
PRECIPITATION	2.48	9002.4
RUNOFF	1.103	4004.8
PERCOLATION FROM LAYER 2	0.0114	41.3
SNOW WATER	3.02	10965.2
MAXIMUM VEG. SOIL WATER (VOL/VOL)	0.3630	
MINIMUM VEG. SOIL WATER (VOL/VOL)	0.0570	

FINAL WATER STORAGE AT END OF YEAR 20

LAYER	(INCHES)	(VOL/VOL)
1	7.58	0.2527
2	340.48	0.3914
SNOW WATER	0.00	

BY RJP DATE 9-4-91

HART ENGINEERS, INC.

SHEET

A-50

OF

PAGE

CHK'D _____ DATE _____

SUBJECT

Cardington Road Landfill
Morgantown, Ohio
Case 6 Simulation

JOB NO. PT059.04

DEFAULT SOIL AND DESIGN DATA INPUT

Title:

Cardington Road Landfill
Case 6 : Using output from Case 3
as input, run for 20 yrs

Do you want the program to initialize the soil water? No

Number of layers: 2

Layer data:

Layer 1

- (a) thickness 30" inches
- (b) layer type 1 - vert. perc. (1 or 2)
- (c) liner leakage fraction (only for layer type 4) — (0 to 1)
- (d) soil texture number #7 (1 to 20)*
- (e) compacted? (only for soil textures 1 to 15) Y (Yes or No)
- (f) initial soil water content (not asked if program is to initialize the soil water or if layer type is 3 or 4) 0.057 vol/vol
(must be between wilting point and porosity) (actual)

Layer 2

- (a) thickness 870" inches
- (b) layer type 1 - vert. perc. (1 to 4)
- (c) liner leakage fraction (only for layer type 4) — (0 to 1)
- (d) soil texture number #18 (1 to 20)*
- (e) compacted? (only for soil textures 1 to 15) — (Yes or No)
- (f) initial soil water content (not asked if program is to initialize the soil water or if layer type is 3 or 4) 0.2942 vol/vol
(must be between wilting point and porosity) (default)

Layer 3

- (a) thickness — inches
- (b) layer type N/Ap
- (c) liner leakage fraction (only for layer type 4) — (0 to 1)
- (d) soil texture number — (1 to 20)*
- (e) compacted? (only for soil textures 1 to 15) — (Yes or No)
- (f) initial soil water content (not asked if program is to initialize the soil water or if layer type is 3 or 4) — vol/vol
(must be between wilting point and porosity)

Layer 4

- (a) _____
- (b) _____
- (c) _____
- (d) _____
- (e) _____
- (f) _____

Layer 5

- (a) _____
- (b) _____
- (c) _____
- (d) _____
- (e) _____
- (f) _____

Layer 6

- (a) _____
- (b) _____
- (c) _____
- (d) _____
- (e) _____
- (f) _____

BY RJP DATE 9-4-91

HART ENGINEERS, INC.

SHEET

A-51
PAGE

CHK'D _____ DATE _____

SUBJECT Cardington Road Landfill JOB NO. PT059.04
Cover Integrity Study

<u>Layer 7</u>			<u>Layer 8</u>			<u>Layer 9</u>			
(a)	_____	(a)	_____	(a)	_____	(b)	_____	(b)	_____
(b)	_____	(b)	_____	(b)	_____	(c)	_____	(c)	_____
(c)	_____	(c)	_____	(c)	_____	(d)	_____	(d)	_____
(d)	_____	(d)	_____	(d)	_____	(e)	_____	(e)	_____
(e)	_____	(e)	_____	(e)	_____	(f)	_____	(f)	_____
(f)	_____	(f)	_____	(f)	_____				
<u>Layer 10</u>			<u>Layer 11</u>			<u>Layer 12</u>			
(a)	_____	(a)	_____	(a)	_____	(b)	_____	(b)	_____
(b)	_____	(b)	_____	(b)	_____	(c)	_____	(c)	_____
(c)	_____	(c)	_____	(c)	_____	(d)	_____	(d)	_____
(d)	_____	(d)	_____	(d)	_____	(e)	_____	(e)	_____
(e)	_____	(e)	_____	(e)	_____	(f)	_____	(f)	_____
(f)	_____	(f)	_____	(f)	_____				

If soil texture number of layer 1 is between 1 and 15, enter:
Type of vegetation: 4 (1 to 5)
SCS runoff curve number (optional): _____ (0 to 100)

If the soil texture number of layer 1 is between 16 and 20, enter:
SCS runoff curve number: _____ (0 to 100)

If landfill is open, enter potential runoff fraction: No (0 to 1)

Surface area: 43,560 square feet

Slope of top liner/drain system: _____ percent
Distance from crest to drain in top liner/drain system: _____ feet

Slope of second liner/drain system: _____ percent
Distance from crest to drain in second liner/drain system: _____ feet

Slope of third liner/drain system: _____ percent
Distance from crest to drain in third liner/drain system: _____ feet

Slope of fourth liner/drain system: _____ percent
Distance from crest to drain in fourth liner/drain system: _____ feet

Initial quantity of snow or ice water on surface (not asked if program is to initialize the soil water): 0.0 inches

* If soil texture number is 19:	If soil texture number is 20:
(a) wilting point _____ vol/vol	(a) wilting point _____ vol/vol
(b) field capacity _____ vol/vol	(b) field capacity _____ vol/vol
(c) porosity _____ vol/vol	(c) porosity _____ vol/vol
(d) saturated hydraulic conductivity _____ cm/sec	(d) saturated hydraulic conductivity _____ cm/sec

CARDINGTON ROAD LANDFILL
MORaine, OHIO
SEPTEMBER 4, 1991

CASE 6

GOOD GRASS

LAYER 1

VERTICAL PERCOLATION LAYER

THICKNESS	=	30.00 INCHES
POROSITY	=	0.3808 VOL/VOL
FIELD CAPACITY	=	0.1924 VOL/VOL
WILTING POINT	=	0.1043 VOL/VOL
INITIAL SOIL WATER CONTENT	=	0.2527 VOL/VOL
SATURATED HYDRAULIC CONDUCTIVITY	=	0.000109199995 CM/SEC

LAYER 2

VERTICAL PERCOLATION LAYER

THICKNESS	=	870.00 INCHES
POROSITY	=	0.5200 VOL/VOL
FIELD CAPACITY	=	0.2942 VOL/VOL
WILTING POINT	=	0.1400 VOL/VOL
INITIAL SOIL WATER CONTENT	=	0.3163 VOL/VOL
SATURATED HYDRAULIC CONDUCTIVITY	=	0.000199999995 CM/SEC

GENERAL SIMULATION DATA

SCS RUNOFF CURVE NUMBER	=	66.43
TOTAL AREA OF COVER	=	43560. SQ FT
EVAPORATIVE ZONE DEPTH	=	21.00 INCHES

UPPER LIMIT VEG. STORAGE = 7.9968 INCHES
 INITIAL VEG. STORAGE = 5.3067 INCHES
 INITIAL SNOW WATER CONTENT = 0.0000 INCHES
 INITIAL TOTAL WATER STORAGE IN SOIL AND WASTE LAYERS = 282.7620 INCHES

SOIL WATER CONTENT INITIALIZED BY USER.

CLIMATOLOGICAL DATA

SYNTHETIC RAINFALL WITH SYNTHETIC DAILY TEMPERATURES AND SOLAR RADIATION FOR COLUMBUS OHIO

MAXIMUM LEAF AREA INDEX = 3.30
 START OF GROWING SEASON (JULIAN DATE) = 121
 END OF GROWING SEASON (JULIAN DATE) = 286

NORMAL MEAN MONTHLY TEMPERATURES, DEGREES FAHRENHEIT

JAN/JUL	FEB/AUG	MAR/SEP	APR/OCT	MAY/NOV	JUN/DEC
26.60	29.60	39.50	51.50	61.80	71.00
74.60	73.00	66.30	54.50	42.10	31.80

AVERAGE MONTHLY VALUES IN INCHES FOR YEARS 1 THROUGH 20

	JAN/JUL	FEB/AUG	MAR/SEP	APR/OCT	MAY/NOV	JUN/DEC
PRECIPITATION						
TOTALS	2.26 3.09	2.09 3.28	3.11 2.44	3.15 2.02	3.51 3.10	4.59 2.44
STD. DEVIATIONS	1.16 1.08	0.87 1.50	1.14 1.07	1.46 1.50	1.20 0.83	1.96 0.92
RUNOFF						
TOTALS	0.001 0.009	0.010 0.016	0.024 0.009	0.004 0.000	0.006 0.000	0.090 0.000
STD. DEVIATIONS	0.002 0.020	0.038 0.030	0.072 0.021	0.014 0.001	0.021 0.000	0.249 0.000
EVAPOTRANSPIRATION						
TOTALS	0.739 3.547	1.188 3.100	2.649 2.380	2.960 1.495	3.666 1.108	5.415 0.754

STD. DEVIATIONS	0.186	0.286	0.330	0.649	1.004	1.374
	1.199	1.348	0.834	0.682	0.209	0.110

PERCOLATION FROM LAYER 2

TOTALS	0.4812	0.4528	0.5160	0.5104	0.5288	0.5056
	0.5140	0.5037	0.4774	0.4833	0.4596	0.4719
STD. DEVIATIONS	0.0775	0.0677	0.0749	0.0792	0.0891	0.0855
	0.0855	0.0819	0.0759	0.0749	0.0682	0.0723

AVERAGE ANNUAL TOTALS & (STD. DEVIATIONS) FOR YEARS 1 THROUGH 20

	(INCHES)	(CU. FT.)	PERCENT
PRECIPITATION	35.08 (3.881)	127346.	100.00
RUNOFF	0.169 (0.250)	612.	0.48
EVAPOTRANSPIRATION	29.001 (3.268)	105275.	82.67
PERCOLATION FROM LAYER 2	5.9046 (0.9019)	21434.	16.83
CHANGE IN WATER STORAGE	0.007 (2.674)	25.	0.02

PEAK DAILY VALUES FOR YEARS 1 THROUGH 20

	(INCHES)	(CU. FT.)
PRECIPITATION	2.48	9002.4
RUNOFF	1.104	4006.1
PERCOLATION FROM LAYER 2	0.0236	85.6
SNOW WATER	3.02	10964.8
MAXIMUM VEG. SOIL WATER (VOL/VOL)	0.3630	
MINIMUM VEG. SOIL WATER (VOL/VOL)	0.1027	

FINAL WATER STORAGE AT END OF YEAR 20

LAYER	(INCHES)	(VOL/VOL)
1	7.58	0.2527
2	275.32	0.3165
SNOW WATER	0.00	

BY RJP DATE 9-4-91

HART ENGINEERS, INC.

SHEET

A-56

OF

PAGE

CHK'D _____ DATE _____

SUBJECT Cardington Road Landfill JOB NO. PT059.04
Moraine, Ohio
Case 7 Simulation

DEFAULT SOIL AND DESIGN DATA INPUT

Title: Cardington Road Landfill
Case 7 - Case 3 except run
using default soil water content values.

Do you want the program to initialize the soil water? yes

Number of layers: 2

Layer data:

Layer 1
(a) thickness 30" inches
(b) layer type 1-vert. perc. (1 or 2)
(c) liner leakage fraction (only for layer type 4) _____ (0 to 1)
(d) soil texture number #7 (1 to 20)*
(e) compacted? (only for soil textures 1 to 15) Y (Yes or No)
(f) initial soil water content (not asked if program is to initialize the soil water or if layer type is 3 or 4) _____ vol/vol
(must be between wilting point and porosity)

Layer 2
(a) thickness 870" inches
(b) layer type 1-vert. perc. (1 to 4)
(c) liner leakage fraction (only for layer type 4) _____ (0 to 1)
(d) soil texture number #18 (1 to 20)*
(e) compacted? (only for soil textures 1 to 15) _____ (Yes or No)
(f) initial soil water content (not asked if program is to initialize the soil water or if layer type is 3 or 4) _____ vol/vol
(must be between wilting point and porosity)

Layer 3
(a) thickness _____ inches
(b) layer type N/Ap
(c) liner leakage fraction (only for layer type 4) _____ (0 to 1)
(d) soil texture number _____ (1 to 20)*
(e) compacted? (only for soil textures 1 to 15) _____ (Yes or No)
(f) initial soil water content (not asked if program is to initialize the soil water or if layer type is 3 or 4) _____ vol/vol
(must be between wilting point and porosity)

<u>Layer 4</u>	<u>Layer 5</u>	<u>Layer 6</u>
(a) _____	(a) _____	(a) _____
(b) _____	(b) _____	(b) _____
(c) _____	(c) _____	(c) _____
(d) _____	(d) _____	(d) _____
(e) _____	(e) _____	(e) _____
(f) _____	(f) _____	(f) _____

BY RJP DATE 9-4-91

HART ENGINEERS, INC.

SHEET

A-57
PAGE

CHK'D _____ DATE _____

SUBJECT Cardington Road Landfill JOB NO. PT059.04
Cover Integrity Study

<u>Layer 7</u> (a) _____ (b) _____ (c) _____ (d) _____ (e) _____ (f) _____	<u>Layer 8</u> (a) _____ (b) _____ (c) _____ (d) _____ (e) _____ (f) _____	<u>Layer 9</u> (a) _____ (b) _____ (c) _____ (d) _____ (e) _____ (f) _____
<u>Layer 10</u> (a) _____ (b) _____ (c) _____ (d) _____ (e) _____ (f) _____	<u>Layer 11</u> (a) _____ (b) _____ (c) _____ (d) _____ (e) _____ (f) _____	<u>Layer 12</u> (a) _____ (b) _____ (c) _____ (d) _____ (e) _____ (f) _____

If soil texture number of layer 1 is between 1 and 15, enter:
 Type of vegetation: 4 (1 to 5)
 SCS runoff curve number (optional): _____ (0 to 100)

If the soil texture number of layer 1 is between 16 and 20, enter:
 SCS runoff curve number: _____ (0 to 100)

If landfill is open, enter potential runoff fraction: No (0 to 1)

Surface area: 43,560 square feet

Slope of top liner/drain system: _____ percent

Distance from crest to drain in top liner/drain system: _____ feet

Slope of second liner/drain system: _____ percent

Distance from crest to drain in second liner/drain system: _____ feet

Slope of third liner/drain system: _____ percent

Distance from crest to drain in third liner/drain system: _____ feet

Slope of fourth liner/drain system: _____ percent

Distance from crest to drain in fourth liner/drain system: _____ feet

Initial quantity of snow or ice water on surface (not asked if program is to initialize the soil water): 0.0 inches

* If soil texture number is 19:

If soil texture number is 20:

(a) wilting point _____ vol/vol
 (b) field capacity _____ vol/vol
 (c) porosity _____ vol/vol
 (d) saturated hydraulic conductivity _____ cm/sec

(a) wilting point _____ vol/vol
 (b) field capacity _____ vol/vol
 (c) porosity _____ vol/vol
 (d) saturated hydraulic conductivity _____ cm/sec

CARDINGTON ROAD LANDFILL
MORaine, OHIO
SEPTEMBER 4, 1991

CASE 7

GOOD GRASS

LAYER 1 -----

VERTICAL PERCOLATION LAYER

THICKNESS	=	30.00 INCHES
POROSITY	=	0.3808 VOL/VOL
FIELD CAPACITY	=	0.1924 VOL/VOL
WILTING POINT	=	0.1043 VOL/VOL
INITIAL SOIL WATER CONTENT	=	0.1924 VOL/VOL
SATURATED HYDRAULIC CONDUCTIVITY	=	0.000109199995 CM/SEC

LAYER 2 -----

VERTICAL PERCOLATION LAYER

THICKNESS	=	870.00 INCHES
POROSITY	=	0.5200 VOL/VOL
FIELD CAPACITY	=	0.2942 VOL/VOL
WILTING POINT	=	0.1400 VOL/VOL
INITIAL SOIL WATER CONTENT	=	0.2942 VOL/VOL
SATURATED HYDRAULIC CONDUCTIVITY	=	0.000199999995 CM/SEC

GENERAL SIMULATION DATA -----

SCS RUNOFF CURVE NUMBER	=	66.43
TOTAL AREA OF COVER	=	43560. SQ FT
EVAPORATIVE ZONE DEPTH	=	21.00 INCHES

UPPER LIMIT VEG. STORAGE = 7.9968 INCHES
 INITIAL VEG. STORAGE = 5.3426 INCHES
 INITIAL SNOW WATER CONTENT = 0.1905 INCHES
 INITIAL TOTAL WATER STORAGE IN SOIL AND WASTE LAYERS = 261.7260 INCHES

SOIL WATER CONTENT INITIALIZED BY PROGRAM.

CLIMATOLOGICAL DATA

SYNTHETIC RAINFALL WITH SYNTHETIC DAILY TEMPERATURES AND SOLAR RADIATION FOR COLUMBUS OHIO

MAXIMUM LEAF AREA INDEX = 3.30
 START OF GROWING SEASON (JULIAN DATE) = 121
 END OF GROWING SEASON (JULIAN DATE) = 286

NORMAL MEAN MONTHLY TEMPERATURES, DEGREES FAHRENHEIT

JAN/JUL	FEB/AUG	MAR/SEP	APR/OCT	MAY/NOV	JUN/DEC
26.60	29.60	39.50	51.50	61.80	71.00
47.60	73.00	66.30	54.50	42.10	31.80

AVERAGE MONTHLY VALUES IN INCHES FOR YEARS 1 THROUGH 20

	JAN/JUL	FEB/AUG	MAR/SEP	APR/OCT	MAY/NOV	JUN/DEC
PRECIPITATION						
TOTALS	2.26 3.09	2.09 3.28	3.11 2.44	3.15 2.02	3.51 3.10	4.59 2.44
STD. DEVIATIONS	1.16 1.08	0.87 1.50	1.14 1.07	1.46 1.50	1.20 0.83	1.96 0.92
RUNOFF						
TOTALS	0.000 0.008	0.011 0.019	0.026 0.011	0.005 0.000	0.006 0.000	0.089 0.000
STD. DEVIATIONS	0.002 0.019	0.038 0.033	0.077 0.023	0.016 0.001	0.021 0.000	0.248 0.000
EVAPOTRANSPIRATION						
TOTALS	0.732 3.416	1.179 3.233	2.639 2.394	2.950 1.515	3.638 1.101	5.418 0.742

STD. DEVIATIONS	0.182	0.281	0.326	0.631	1.021	1.375
	1.154	1.381	0.843	0.724	0.210	0.106

PERCOLATION FROM LAYER 2

TOTALS	0.3975	0.3766	0.4306	0.4271	0.4443	0.4263
	0.4343	0.4265	0.4051	0.4109	0.3914	0.4030

STD. DEVIATIONS	0.1360	0.1267	0.1414	0.1402	0.1491	0.1423
	0.1424	0.1373	0.1281	0.1276	0.1184	0.1229

AVERAGE ANNUAL TOTALS & (STD. DEVIATIONS) FOR YEARS 1 THROUGH 20

	(INCHES)	(CU. FT.)	PERCENT
PRECIPITATION	35.08 (3.881)	127346.	100.00
RUNOFF	0.175 (0.248)	637.	0.50
EVAPOTRANSPIRATION	28.956 (3.316)	105109.	82.54
PERCOLATION FROM LAYER 2	4.9736 (1.5973)	18054.	14.18
CHANGE IN WATER STORAGE	0.977 (2.780)	3546.	2.78

PEAK DAILY VALUES FOR YEARS 1 THROUGH 20

	(INCHES)	(CU. FT.)
PRECIPITATION	2.48	9002.4
RUNOFF	1.100	3993.2
PERCOLATION FROM LAYER 2	0.0234	85.0
SNOW WATER	3.03	11001.6
MAXIMUM VEG. SOIL WATER (VOL/VOL)	0.3631	
MINIMUM VEG. SOIL WATER (VOL/VOL)	0.1027	

FINAL WATER STORAGE AT END OF YEAR 20

LAYER	(INCHES)	(VOL/VOL)
1	7.60	0.2532
2	275.20	0.3163
SNOW WATER	0.00	

BY RJP DATE 9-4-91

HART ENGINEERS, INC.

SHEET

A-62

OF

PAGE

CHK'D _____ DATE _____

SUBJECT Cardington Road Landfill JOB NO. PRO59.04
Moraine, Ohio
Case 8 Simulation

DEFAULT SOIL AND DESIGN DATA INPUT

Title: Cardington Road Landfill
Case 8 - Case 1 except run four
times to achieve 20 years.

Do you want the program to initialize the soil water? No

Number of layers: 2

Layer data:

Layer 1

- (a) thickness 30" inches
- (b) layer type 1-vert. perc. (1 or 2)
- (c) liner leakage fraction (only for layer type 4) — (0 to 1)
- (d) soil texture number #7 (1 to 20)*
- (e) compacted? (only for soil textures 1 to 15) Y (Yes or No)
- (f) initial soil water content (not asked if program is to initialize the soil water or if layer type is 3 or 4) 0.057 vol/vol
(must be between wilting point and porosity) (actual)

Layer 2

- (a) thickness 870" inches
- (b) layer type 1-vert. perc. (1 to 4)
- (c) liner leakage fraction (only for layer type 4) — (0 to 1)
- (d) soil texture number #18 (1 to 20)*
- (e) compacted? (only for soil textures 1 to 15) — (Yes or No)
- (f) initial soil water content (not asked if program is to initialize the soil water or if layer type is 3 or 4) 0.2942 vol/vol
(must be between wilting point and porosity) (default)

Layer 3

- (a) thickness — inches
- (b) layer type N/A
- (c) liner leakage fraction (only for layer type 4) — (0 to 1)
- (d) soil texture number — (1 to 20)*
- (e) compacted? (only for soil textures 1 to 15) — (Yes or No)
- (f) initial soil water content (not asked if program is to initialize the soil water or if layer type is 3 or 4) — vol/vol
(must be between wilting point and porosity)

Layer 4

- (a) _____
- (b) _____
- (c) _____
- (d) _____
- (e) _____
- (f) _____

Layer 5

- (a) _____
- (b) _____
- (c) _____
- (d) _____
- (e) _____
- (f) _____

Layer 6

- (a) _____
- (b) _____
- (c) _____
- (d) _____
- (e) _____
- (f) _____

BY RJP DATE 9-4-91
CHK'D _____ DATE _____

HART ENGINEERS, INC.

SHEET A-13
OF _____
PAGE

SUBJECT Cardington Road Landfill JOB NO. PT059.04
Cover Integrity Study

<u>Layer 7</u>			<u>Layer 8</u>			<u>Layer 9</u>		
(a)	_____		(a)	_____		(a)	_____	
(b)	_____		(b)	_____		(b)	_____	
(c)	_____		(c)	_____		(c)	_____	
(d)	_____		(d)	_____		(d)	_____	
(e)	_____		(e)	_____		(e)	_____	
(f)	_____		(f)	_____		(f)	_____	
<u>Layer 10</u>			<u>Layer 11</u>			<u>Layer 12</u>		
(a)	_____		(a)	_____		(a)	_____	
(b)	_____		(b)	_____		(b)	_____	
(c)	_____		(c)	_____		(c)	_____	
(d)	_____		(d)	_____		(d)	_____	
(e)	_____		(e)	_____		(e)	_____	
(f)	_____		(f)	_____		(f)	_____	

If soil texture number of layer 1 is between 1 and 15, enter:
Type of vegetation: 4 (1 to 5)
SCS runoff curve number (optional): _____ (0 to 100)

If the soil texture number of layer 1 is between 16 and 20, enter:
SCS runoff curve number: _____ (0 to 100)

If landfill is open, enter potential runoff fraction: No (0 to 1)

Surface area: 43,560 square feet

Slope of top liner/drain system: _____ percent
Distance from crest to drain in top liner/drain system: _____ feet

Slope of second liner/drain system: _____ percent
Distance from crest to drain in second liner/drain system: _____ feet

Slope of third liner/drain system: _____ percent
Distance from crest to drain in third liner/drain system: _____ feet

Slope of fourth liner/drain system: _____ percent
Distance from crest to drain in fourth liner/drain system: _____ feet

Initial quantity of snow or ice water on surface (not asked if program is to initialize the soil water): 0.0 inches

* If soil texture number is 19: If soil texture number is 20:
(a) wilting point _____ vol/vol (a) wilting point _____ vol/vol
(b) field capacity _____ vol/vol (b) field capacity _____ vol/vol
(c) porosity _____ vol/vol (c) porosity _____ vol/vol
(d) saturated hydraulic conductivity _____ ca/sec (d) saturated hydraulic conductivity _____ ca/sec

CARDINGTON ROAD LANDFILL
MORaine, OHIO
SEPTEMBER 4, 1991

CASE 8

GOOD GRASS

LAYER 1

VERTICAL PERCOLATION LAYER

THICKNESS	=	30.00 INCHES
POROSITY	=	0.3808 VOL/VOL
FIELD CAPACITY	=	0.1924 VOL/VOL
WILTING POINT	=	0.1043 VOL/VOL
INITIAL SOIL WATER CONTENT	=	0.0570 VOL/VOL
SATURATED HYDRAULIC CONDUCTIVITY	=	0.000109199995 CM/SEC

LAYER 2

VERTICAL PERCOLATION LAYER

THICKNESS	=	870.00 INCHES
POROSITY	=	0.5200 VOL/VOL
FIELD CAPACITY	=	0.2942 VOL/VOL
WILTING POINT	=	0.1400 VOL/VOL
INITIAL SOIL WATER CONTENT	=	0.2942 VOL/VOL
SATURATED HYDRAULIC CONDUCTIVITY	=	0.000199999995 CM/SEC

GENERAL SIMULATION DATA

SCS RUNOFF CURVE NUMBER	=	66.43
TOTAL AREA OF COVER	=	43560. SQ FT
EVAPORATIVE ZONE DEPTH	=	21.00 INCHES

UPPER LIMIT VEG. STORAGE = 7.9968 INCHES
 INITIAL VEG. STORAGE = 1.1970 INCHES
 INITIAL SNOW WATER CONTENT = 0.0000 INCHES
 INITIAL TOTAL WATER STORAGE IN SOIL AND WASTE LAYERS = 257.6640 INCHES

SOIL WATER CONTENT INITIALIZED BY USER.

CLIMATOLOGICAL DATA

DEFAULT RAINFALL WITH SYNTHETIC DAILY TEMPERATURES AND SOLAR RADIATION FOR COLUMBUS OHIO

MAXIMUM LEAF AREA INDEX = 3.30
 START OF GROWING SEASON (JULIAN DATE) = 121
 END OF GROWING SEASON (JULIAN DATE) = 286

NORMAL MEAN MONTHLY TEMPERATURES, DEGREES FAHRENHEIT

JAN/JUL	FEB/AUG	MAR/SEP	APR/OCT	MAY/NOV	JUN/DEC
27.10	29.80	40.00	51.40	61.40	70.20
73.80	72.40	65.80	53.90	42.10	32.10

AVERAGE MONTHLY VALUES IN INCHES FOR YEARS 74 THROUGH 78

	JAN/JUL	FEB/AUG	MAR/SEP	APR/OCT	MAY/NOV	JUN/DEC
PRECIPITATION						
TOTALS	3.23 2.67	1.83 4.76	3.50 3.16	2.77 2.48	2.56 1.96	4.05 3.12
STD. DEVIATIONS	1.60 1.56	1.20 0.23	0.91 1.61	0.93 0.63	1.41 1.09	0.69 1.48
RUNOFF						
TOTALS	0.174 0.007	0.046 0.045	0.040 0.015	0.000 0.014	0.000 0.003	0.017 0.014
STD. DEVIATIONS	0.388 0.016	0.103 0.097	0.063 0.032	0.000 0.019	0.000 0.007	0.028 0.030
EVAPOTRANSPIRATION						
TOTALS	0.670 3.107	1.255 3.742	2.163 3.567	2.713 1.845	2.723 1.283	5.444 0.666

STD. DEVIATIONS	0.205	0.295	0.299	0.777	0.895	1.271
	1.515	0.788	0.660	0.239	0.140	0.105

PERCOLATION FROM LAYER 2

TOTALS	0.2420	0.2352	0.2672	0.2637	0.2735	0.2631
	0.2693	0.2664	0.2549	0.2604	0.2491	0.2579

STD. DEVIATIONS	0.0502	0.0590	0.0622	0.0583	0.0595	0.0569
	0.0579	0.0568	0.0538	0.0545	0.0516	0.0541

AVERAGE ANNUAL TOTALS & (STD. DEVIATIONS) FOR YEARS 74 THROUGH 78

	(INCHES)	(CU. FT.)	PERCENT
PRECIPITATION	36.09 (2.628)	131021.	100.00
RUNOFF	0.374 (0.338)	1357.	1.04
EVAPOTRANSPIRATION	29.178 (1.053)	105917.	80.84
PERCOLATION FROM LAYER 2	3.1027 (0.6634)	11263.	8.60
CHANGE IN WATER STORAGE	3.439 (3.234)	12484.	9.53

PEAK DAILY VALUES FOR YEARS 74 THROUGH 78

	(INCHES)	(CU. FT.)
PRECIPITATION	2.32	8421.6
RUNOFF	0.867	3147.2
PERCOLATION FROM LAYER 2	0.0116	42.2
SNOW WATER	1.50	5430.7
MAXIMUM VEG. SOIL WATER (VOL/VOL)	0.3735	
MINIMUM VEG. SOIL WATER (VOL/VOL)	0.0570	

FINAL WATER STORAGE AT END OF YEAR 78

LAYER	(INCHES)	(VOL/VOL)
1	8.25	0.2750
2	266.61	0.3064
SNOW WATER	0.00	

CARDINGTON RAOD LANDFILL
MORAINNE, OHIO
SEPTEMBER 4, 1991

GOOD GRASS

LAYER 1

VERTICAL PERCOLATION LAYER

THICKNESS	=	30.00 INCHES
POROSITY	=	0.3808 VOL/VOL
FIELD CAPACITY	=	0.1924 VOL/VOL
WILTING POINT	=	0.1043 VOL/VOL
INITIAL SOIL WATER CONTENT	=	0.2750 VOL/VOL
SATURATED HYDRAULIC CONDUCTIVITY	=	0.000109199995 CM/SEC

LAYER 2

VERTICAL PERCOLATION LAYER

THICKNESS	=	870.00 INCHES
POROSITY	=	0.5200 VOL/VOL
FIELD CAPACITY	=	0.2942 VOL/VOL
WILTING POINT	=	0.1400 VOL/VOL
INITIAL SOIL WATER CONTENT	=	0.3064 VOL/VOL
SATURATED HYDRAULIC CONDUCTIVITY	=	0.000199999995 CM/SEC

GENERAL SIMULATION DATA

SCS RUNOFF CURVE NUMBER	=	66.43
TOTAL AREA OF COVER	=	43560. SQ FT
EVAPORATIVE ZONE DEPTH	=	21.00 INCHES

UPPER LIMIT VEG. STORAGE = 7.9968 INCHES
 INITIAL VEG. STORAGE = 5.7750 INCHES
 INITIAL SNOW WATER CONTENT = 0.0000 INCHES
 INITIAL TOTAL WATER STORAGE IN
 SOIL AND WASTE LAYERS = 274.8180 INCHES

SOIL WATER CONTENT INITIALIZED BY USER.

CLIMATOLOGICAL DATA

DEFAULT RAINFALL WITH SYNTHETIC DAILY TEMPERATURES AND
 SOLAR RADIATION FOR COLUMBUS OHIO

MAXIMUM LEAF AREA INDEX = 3.30
 START OF GROWING SEASON (JULIAN DATE) = 121
 END OF GROWING SEASON (JULIAN DATE) = 286

NORMAL MEAN MONTHLY TEMPERATURES, DEGREES FAHRENHEIT

JAN/JUL	FEB/AUG	MAR/SEP	APR/OCT	MAY/NOV	JUN/DEC
-----	-----	-----	-----	-----	-----
27.10	29.80	40.00	51.40	61.40	70.20
73.80	72.40	65.80	53.90	42.10	32.10

AVERAGE MONTHLY VALUES IN INCHES FOR YEARS 74 THROUGH 78

	JAN/JUL	FEB/AUG	MAR/SEP	APR/OCT	MAY/NOV	JUN/DEC
-----	-----	-----	-----	-----	-----	-----
PRECIPITATION						
TOTALS	3.23 2.67	1.83 4.76	3.50 3.16	2.77 2.48	2.56 1.96	4.05 3.12
STD. DEVIATIONS	1.60 1.56	1.20 0.23	0.91 1.61	0.93 0.63	1.41 1.09	0.69 1.48
RUNOFF						
TOTALS	0.174 0.007	0.046 0.045	0.044 0.015	0.000 0.014	0.000 0.003	0.017 0.013
STD. DEVIATIONS	0.388 0.016	0.103 0.097	0.072 0.032	0.000 0.019	0.000 0.007	0.028 0.030
EVAPOTRANSPIRATION						
TOTALS	0.700 3.106	1.267 3.740	2.189 3.559	2.705 1.854	2.746 1.292	5.438 0.669

STD. DEVIATIONS 0.206 0.301 0.322 0.781 0.930 1.267
 1.516 0.789 0.652 0.229 0.141 0.108

PERCOLATION FROM LAYER 2

TOTALS 0.4058 0.3956 0.4501 0.4448 0.4610 0.4407
 0.4482 0.4403 0.4184 0.4246 0.4035 0.4144

STD. DEVIATIONS 0.0497 0.0587 0.0602 0.0520 0.0455 0.0417
 0.0415 0.0399 0.0373 0.0372 0.0347 0.0330

AVERAGE ANNUAL TOTALS & (STD. DEVIATIONS) FOR YEARS 74 THROUGH 78

	(INCHES)	(CU. FT.)	PERCENT
PRECIPITATION	36.09 (2.628)	131021.	100.00
RUNOFF	0.378 (0.335)	1373.	1.05
EVAPOTRANSPIRATION	29.265 (1.108)	106233.	81.08
PERCOLATION FROM LAYER 2	5.1474 (0.5060)	18685.	14.26
CHANGE IN WATER STORAGE	1.303 (3.174)	4730.	3.61

PEAK DAILY VALUES FOR YEARS 74 THROUGH 78

	(INCHES)	(CU. FT.)
PRECIPITATION	2.32	8421.6
RUNOFF	0.867	3147.0
PERCOLATION FROM LAYER 2	0.0167	60.7
SNOW WATER	1.50	5430.7
MAXIMUM VEG. SOIL WATER (VOL/VOL)	0.3735	
MINIMUM VEG. SOIL WATER (VOL/VOL)	0.1041	

FINAL WATER STORAGE AT END OF YEAR 78

LAYER	(INCHES)	(VOL/VOL)
1	8.25	0.2750
2	273.08	0.3139
SNOW WATER	0.00	

CARDINGTON ROAD LANDFILL
MORaine, OHIO
SEPTEMBER 4, 1991

GOOD GRASS

LAYER 1

VERTICAL PERCOLATION LAYER

THICKNESS	=	30.00 INCHES
POROSITY	=	0.3808 VOL/VOL
FIELD CAPACITY	=	0.1924 VOL/VOL
WILTING POINT	=	0.1043 VOL/VOL
INITIAL SOIL WATER CONTENT	=	0.2750 VOL/VOL
SATURATED HYDRAULIC CONDUCTIVITY	=	0.000109199995 CM/SEC

LAYER 2

VERTICAL PERCOLATION LAYER

THICKNESS	=	870.00 INCHES
POROSITY	=	0.5200 VOL/VOL
FIELD CAPACITY	=	0.2942 VOL/VOL
WILTING POINT	=	0.1400 VOL/VOL
INITIAL SOIL WATER CONTENT	=	0.3139 VOL/VOL
SATURATED HYDRAULIC CONDUCTIVITY	=	0.000199999995 CM/SEC

GENERAL SIMULATION DATA

SCS RUNOFF CURVE NUMBER	=	66.43
TOTAL AREA OF COVER	=	43560. SQ FT
EVAPORATIVE ZONE DEPTH	=	21.00 INCHES

UPPER LIMIT VEG. STORAGE = 7.9968 INCHES
 INITIAL VEG. STORAGE = 5.7750 INCHES
 INITIAL SNOW WATER CONTENT = 0.0000 INCHES
 INITIAL TOTAL WATER STORAGE IN SOIL AND WASTE LAYERS = 281.3430 INCHES

SOIL WATER CONTENT INITIALIZED BY USER.

CLIMATOLOGICAL DATA

DEFAULT RAINFALL WITH SYNTHETIC DAILY TEMPERATURES AND SOLAR RADIATION FOR COLUMBUS OHIO

MAXIMUM LEAF AREA INDEX = 3.30
 START OF GROWING SEASON (JULIAN DATE) = 121
 END OF GROWING SEASON (JULIAN DATE) = 286

NORMAL MEAN MONTHLY TEMPERATURES, DEGREES FAHRENHEIT

JAN/JUL	FEB/AUG	MAR/SEP	APR/OCT	MAY/NOV	JUN/DEC
27.10	29.80	40.00	51.40	61.40	70.20
73.80	72.40	65.80	53.90	42.10	32.10

AVERAGE MONTHLY VALUES IN INCHES FOR YEARS 74 THROUGH 78

	JAN/JUL	FEB/AUG	MAR/SEP	APR/OCT	MAY/NOV	JUN/DEC
PRECIPITATION						
TOTALS	3.23	1.83	3.50	2.77	2.56	4.05
	2.67	4.76	3.16	2.48	1.96	3.12
STD. DEVIATIONS	1.60	1.20	0.91	0.93	1.41	0.69
	1.56	0.23	1.61	0.63	1.09	1.48
RUNOFF						
TOTALS	0.174	0.046	0.044	0.000	0.000	0.017
	0.007	0.045	0.015	0.014	0.003	0.013
STD. DEVIATIONS	0.388	0.103	0.072	0.000	0.000	0.028
	0.016	0.097	0.032	0.019	0.007	0.030
EVAPOTRANSPIRATION						
TOTALS	0.700	1.267	2.189	2.705	2.746	5.438
	3.106	3.740	3.559	1.854	1.292	0.669

STD. DEVIATIONS	0.206	0.301	0.322	0.781	0.930	1.267
	1.516	0.789	0.652	0.229	0.141	0.108

PERCOLATION FROM LAYER 2

TOTALS	0.4898	0.4751	0.5390	0.5310	0.5484	0.5224
	0.5294	0.5183	0.4911	0.4968	0.4707	0.4817
STD. DEVIATIONS	0.0315	0.0476	0.0553	0.0520	0.0464	0.0425
	0.0422	0.0404	0.0375	0.0372	0.0346	0.0276

AVERAGE ANNUAL TOTALS & (STD. DEVIATIONS) FOR YEARS 74 THROUGH 78

	(INCHES)	(CU. FT.)	PERCENT
PRECIPITATION	36.09 (2.628)	131021.	100.00
RUNOFF	0.378 (0.335)	1373.	1.05
EVAPOTRANSPIRATION	29.266 (1.108)	106234.	81.08
PERCOLATION FROM LAYER 2	6.0939 (0.4532)	22121.	16.88
CHANGE IN WATER STORAGE	0.356 (3.141)	1293.	0.99

PEAK DAILY VALUES FOR YEARS 74 THROUGH 78

	(INCHES)	(CU. FT.)
PRECIPITATION	2.32	8421.6
RUNOFF	0.867	3146.9
PERCOLATION FROM LAYER 2	0.0197	71.5
SNOW WATER	1.50	5430.7
MAXIMUM VEG. SOIL WATER (VOL/VOL)	0.3735	
MINIMUM VEG. SOIL WATER (VOL/VOL)	0.1041	

FINAL WATER STORAGE AT END OF YEAR 78

LAYER	(INCHES)	(VOL/VOL)
1	8.25	0.2750
2	274.87	0.3159
SNOW WATER	0.00	

CARDINGTON ROAD LANDFILL
MORaine, OHIO
SEPTEMBER 4, 1991

GOOD GRASS

LAYER 1

VERTICAL PERCOLATION LAYER

THICKNESS	=	30.00 INCHES
POROSITY	=	0.3808 VOL/VOL
FIELD CAPACITY	=	0.1924 VOL/VOL
WILTING POINT	=	0.1043 VOL/VOL
INITIAL SOIL WATER CONTENT	=	0.2750 VOL/VOL
SATURATED HYDRAULIC CONDUCTIVITY	=	0.000109199995 CM/SEC

LAYER 2

VERTICAL PERCOLATION LAYER

THICKNESS	=	870.00 INCHES
POROSITY	=	0.5200 VOL/VOL
FIELD CAPACITY	=	0.2942 VOL/VOL
WILTING POINT	=	0.1400 VOL/VOL
INITIAL SOIL WATER CONTENT	=	0.3159 VOL/VOL
SATURATED HYDRAULIC CONDUCTIVITY	=	0.000199999995 CM/SEC

GENERAL SIMULATION DATA

SCS RUNOFF CURVE NUMBER	=	66.43
TOTAL AREA OF COVER	=	43560. SQ FT
EVAPORATIVE ZONE DEPTH	=	21.00 INCHES

UPPER LIMIT VEG. STORAGE = 7.9968 INCHES
 INITIAL VEG. STORAGE = 5.7750 INCHES
 INITIAL SNOW WATER CONTENT = 0.0000 INCHES
 INITIAL TOTAL WATER STORAGE IN SOIL AND WASTE LAYERS = 283.0830 INCHES

SOIL WATER CONTENT INITIALIZED BY USER.

CLIMATOLOGICAL DATA

DEFAULT RAINFALL WITH SYNTHETIC DAILY TEMPERATURES AND SOLAR RADIATION FOR COLUMBUS OHIO

MAXIMUM LEAF AREA INDEX = 3.30
 START OF GROWING SEASON (JULIAN DATE) = 121
 END OF GROWING SEASON (JULIAN DATE) = 286

NORMAL MEAN MONTHLY TEMPERATURES, DEGREES FAHRENHEIT

JAN/JUL	FEB/AUG	MAR/SEP	APR/OCT	MAY/NOV	JUN/DEC
27.10	29.80	40.00	51.40	61.40	70.20
73.80	72.40	65.80	53.90	42.10	32.10

AVERAGE MONTHLY VALUES IN INCHES FOR YEARS 74 THROUGH 78

	JAN/JUL	FEB/AUG	MAR/SEP	APR/OCT	MAY/NOV	JUN/DEC
PRECIPITATION						
TOTALS	3.23 2.67	1.83 4.76	3.50 3.16	2.77 2.48	2.56 1.96	4.05 3.12
STD. DEVIATIONS	1.60 1.56	1.20 0.23	0.91 1.61	0.93 0.63	1.41 1.09	0.69 1.48
RUNOFF						
TOTALS	0.174 0.007	0.046 0.045	0.044 0.015	0.000 0.014	0.000 0.003	0.017 0.013
STD. DEVIATIONS	0.388 0.016	0.103 0.097	0.072 0.032	0.000 0.019	0.000 0.007	0.028 0.030
EVAPOTRANSPIRATION						
TOTALS	0.700 3.106	1.267 3.740	2.189 3.559	2.705 1.854	2.746 1.292	5.438 0.669

STD. DEVIATIONS	0.206	0.301	0.322	0.781	0.930	1.267
	1.516	0.789	0.652	0.229	0.141	0.108

PERCOLATION FROM LAYER 2

TOTALS	0.5138	0.4976	0.5642	0.5553	0.5729	0.5452
	0.5520	0.5399	0.5111	0.5166	0.4891	0.5001
STD. DEVIATIONS	0.0282	0.0462	0.0572	0.0559	0.0513	0.0472
	0.0469	0.0449	0.0416	0.0412	0.0382	0.0303

AVERAGE ANNUAL TOTALS & (STD. DEVIATIONS) FOR YEARS 74 THROUGH 78

	(INCHES)	(CU. FT.)	PERCENT
PRECIPITATION	36.09 (2.628)	131021.	100.00
RUNOFF	0.378 (0.335)	1373.	1.05
EVAPOTRANSPIRATION	29.266 (1.108)	106235.	81.08
PERCOLATION FROM LAYER 2	6.3578 (0.4889)	23079.	17.61
CHANGE IN WATER STORAGE	0.092 (3.136)	334.	0.26

PEAK DAILY VALUES FOR YEARS 74 THROUGH 78

	(INCHES)	(CU. FT.)
PRECIPITATION	2.32	8421.6
RUNOFF	0.867	3146.9
PERCOLATION FROM LAYER 2	0.0208	75.5
SNOW WATER	1.50	5430.7
MAXIMUM VEG. SOIL WATER (VOL/VOL)	0.3735	
MINIMUM VEG. SOIL WATER (VOL/VOL)	0.1041	

FINAL WATER STORAGE AT END OF YEAR 78

LAYER	(INCHES)	(VOL/VOL)
1	8.25	0.2750
2	275.29	0.3164
SNOW WATER	0.00	

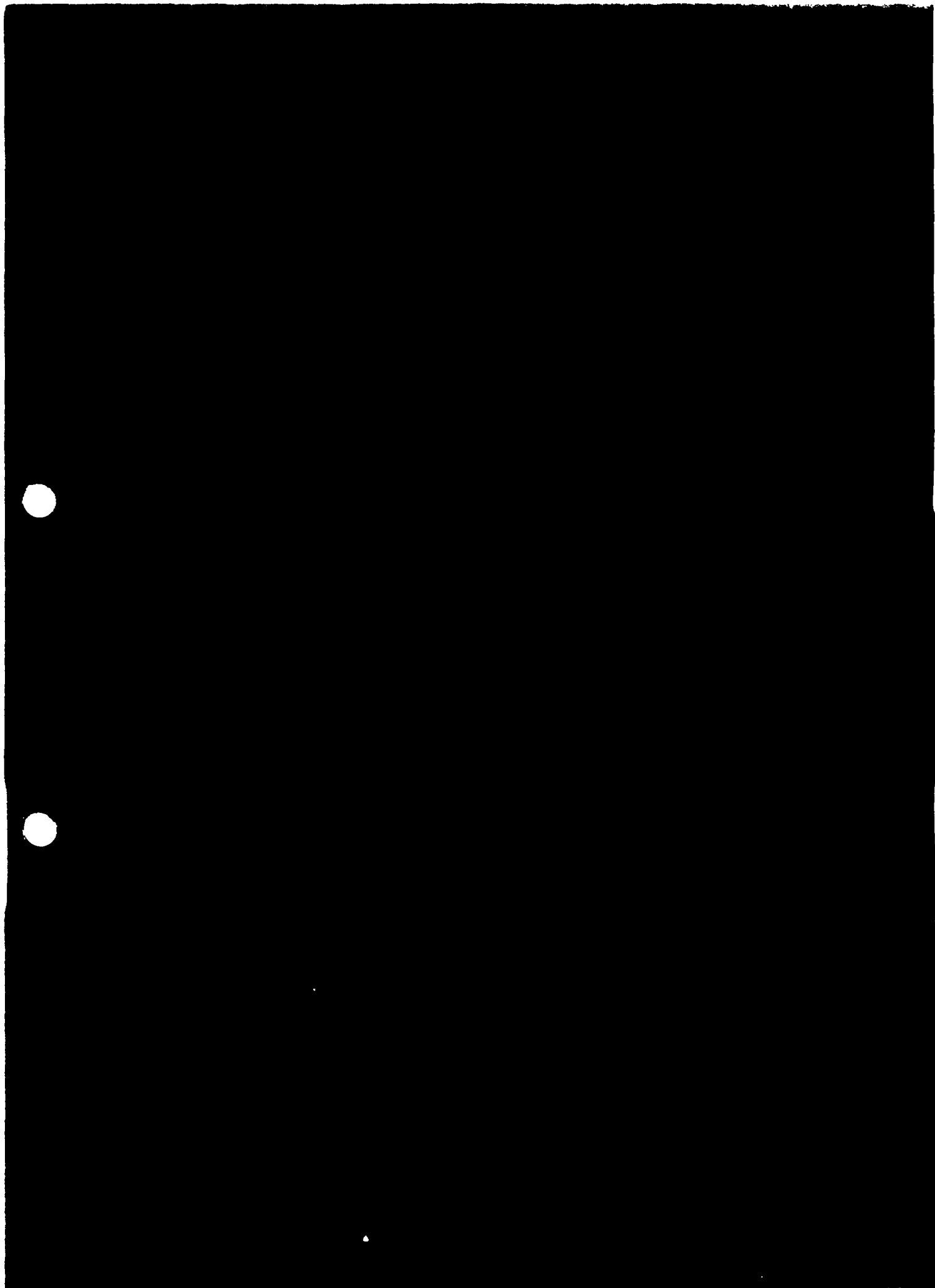

APPENDIX H

**ON-SITE GAS VENT MODELING
DESCRIPTION (bound separately with
Risk Assessment)**



APPENDIX I

**CONCEPTUAL MODEL TO PREDICT
FUTURE GROUND WATER CONCENTRATIONS
BASED ON LEACHATE DATA**

**CONCEPTUAL MODEL TO PREDICT
FUTURE GROUND WATER CONCENTRATIONS
BASED ON LEACHATE DATA**

Currently, public water supplies are available in the area as a source of drinking water. To evaluate the potential future use of the ground water and to evaluate the potential future migration of chemicals in the ground water if no remedial action is conducted at the Site, a conceptual model was used to predict future concentrations. The model simulates the concentrations of the chemicals of concern (developed in the Risk Assessment) found in the leachate and models these concentrations to the ground water. By this mass-balance approach, the concentrations in the leachate are modelled to the regional aquifer directly. No provision to address the attenuation and the degradation of the constituents that would occur in the unsaturated zone beneath the landfill is taken into account. The model therefore predicts very conservative values. The amount of water discharging from the base of the landfill was taken from the HELP analyses (4 inches per acre per year) described in the cap integrity assessment. The predicted future concentrations from the modelling for the chemicals of potential concern presented in the Risk Assessment (see Section 5.0 bound separately) are presented in Table I-1. Figure I-1 presents a graphical interpretation of the model. The modelling approach is discussed below.

The geology consists of two distinctive deposits of varying extent and permeability. The deposits include a very permeable sand and gravel outwash deposit and a clay-rich grey till deposit. The saturated sand and gravel deposits consist of a perched zone and the regional aquifer. The perched saturated zone exists where the sand and gravel deposits are separated by a low permeability till, which is situated along the western and northeastern margin of the site. In the area where the till is present, the sand and gravel is approximately 60 feet to 90 feet thick and has approximately 10 feet to 15 feet of saturation at the top of the till. Underlying the till, the sand and gravel deposits are approximately 200 feet thick and have about 143 feet of saturation. In areas where the till is absent, the first encountered saturated zone is the regional aquifer at a depth of approximately 130 feet below the surface.

To evaluate the potential fate and transport of organic and inorganic compounds from the landfill into the regional aquifer, a one-dimensional model has been developed using the physical characteristics of the Site. Figure I-1 illustrates the conceptual model along the north-south profile of the western margin of the Site. Superimposed on the model are the horizontal and vertical flow directions or potential pathways away from the landfill. By using measured analyte concentrations from the leachate head wells and calculated quantities of flow and mass balance principles, worst-case scenario compound concentrations were estimated. See Table I-1 for a list of parameters.

This model is a simplistic approach to estimate conservative values for the compound concentrations in the regional aquifer. The model assumes that concentrations of constituents emitted from the base of the landfill instantaneously enters the aquifer; the flow through the unsaturated zone is not modelled. Attenuation, degradation, and adsorption processes, which would reduce actual constituent concentrations in the regional aquifer beneath the Site, are excluded from the model.

The quantity of flow from the bottom of the landfill and the quantity of ground water flow in the regional aquifer under the Site can be calculated from the following equation:

$$Q = KIA$$

where

Q = flow (gallons per day (gpd))

K = hydraulic conductivity (gpd/ft²)

I = hydraulic gradient (ft/ft)

A = area (ft²)

The calculation for the quantities of flow assuming 1 inch of net drainage from the base of the landfill calculated in the HELP model are as follows:

Q₁ = total flow available from bottom of landfill

$$Q_{1a} = (1 \text{ in/yr}) * (1 \text{ yr}/365 \text{ day}) * (1 \text{ ft}/12 \text{ in}) * (7.48 \text{ gal}/\text{ft}^3) * (2,050 \text{ ft} * 1,100 \text{ ft})$$

$$Q_{1b} = 3,851 \text{ gpd}$$

Q_{1b} using 4 ins/yr as calculated by the HELP model

$$Q_{1b} = \left(\frac{4 \text{ in/yr}}{\text{ft}^3} \right) * (1 \text{ yr/365 day}) * (1 \text{ ft/12 in}) * (7.48 \text{ gal/ft}^3) * (2,050 \text{ ft} * 1,100 \text{ ft})$$

$$Q_{1b} = 15,404 \text{ gpd}$$

Q_2 = horizontal flow in principal aquifer (no confining layer)

$$Q_2 = KIA$$

$$Q_2 = (2,000 \text{ gpd/ft}^2w) * (.0003 \text{ ft/ft}) * (2,100 \text{ ft} * 143 \text{ ft})$$

$$Q_2 = 180,180 \text{ gpd}$$

Using the principles of mass balance and known organic and inorganic analyte concentrations in the leachate, the concentration of a particular compound can be calculated by using the following:

$$Q_x (\text{conc.}_x) = Q_y (\text{conc.}_y)$$

where

Q = flow at any given point x or y

conc. = concentration of a compound or element at any given point x or y

The concentrations used in the calculations are the exposure concentration calculated from the leachate samples presented in the Risk Assessment.

Calculations using 4 in/yr flow rate:

$$Q_1 (\text{conc.}_1) = Q_{2a} (\text{conc.}_2)$$

$$(180,180 \text{ gpd}) * (x) = 15,404 \text{ gpd} * (0.0137 \text{ mg/l}) \text{ benzene} = 1.17 \times 10^{-3} \text{ mg/l} - \text{conc.}_{2a} \text{ of benzene}$$

This calculation assumes steady state conditions and that the leachate flows from the landfill and instantaneously enters into the aquifer. Approximately 70 feet of unsaturated soil; however, exists above the aquifer. Flow rates through this unsaturated zone will be very slow and attenuation, adsorption, and degradation would decrease concentrations in the unsaturated zones considerably. Thus, the concentrations presented in Table I-1 likely present a conservative scenario.

These predicted concentrations of compounds of concern in the regional water table extrapolated from the leachate data are subsequently used in the Risk Assessment to calculate the future exposure risk, if any, associated with ground water use under a hypothetical future residential use scenario as specified by USEPA. The calculations in the Risk Assessment address the factors of attenuation, degradation, adsorption, and other factors that address the migration of chemicals through the unsaturated zone. A detailed discussion of the future risk calculations are provided in the Risk Assessment (bound separately).

TABLE I-1
SUMMARY OF PREDICTED CONCENTRATIONS OF COMPOUNDS OF CONCERN
IN REGIONAL AQUIFER EXTRAPOLATED FROM LEACHATE DATA
CARDINGTON ROAD LANDFILL SITE
MORaine, OHIO

PARAMETER	LANDFILL*	PREDICTED CONCENTRATIONS
	LEACHATE CONC. (mg/l)	IN REGIONAL AQUIFER *** 4 in/yr** (mg/l)
Acetone	0.0344	2.94E-03
Benzene	0.0137	1.17E-03
Benzyl Chloride	ND	
Bromodichloromethane	0.0025	2.14E-04
1,1-Dichloroethane	ND	
Tetrachloroethene	0.0072	6.16E-04
Trichloroethene	0.0025	2.14E-04
Vinyl Chloride	ND	
1,1-Dichloroethene	ND	
1,2-Dichloroethene (total)	0.0025	2.14E-04
Chlorobenzene	0.0119	1.02E-03
Chloroethane	0.0163	1.39E-03
Chloroform	0.0025	2.14E-04
Dichlorodifluoromethane	ND	
1,2-Dichloro-1,1,2,2-tetrafluoroethane	ND	
Ethylbenzene	0.2516	2.15E-02
Hexane	ND	
2-Butanone	0.0395	3.38E-03
2-Hexanone	0.9415	8.05E-02
Methane	NA	
4-Methyl-2-pentanone	0.0524	4.48E-03
Methylene chloride	0.1513	1.29E-02
Toluene	0.1906	1.63E-02
1,1,2-Trichloroethane	0.0122	1.04E-03
1,1,1-Trichloroethane	ND	
Xylenes (total)	2.7154	2.32E-01
1,4-Dichlorobenzene	0.005	4.27E-04
2,4-Dimethylphenol	0.0177	1.51E-03
2-Methylnaphthalene	0.0062	5.30E-04
2-Methylphenol	0.0144	1.23E-03
4-Methylphenol	0.087	7.44E-03
Acenaphthene	0.0071	6.07E-04
Anthracene	0.0075	6.41E-04
Benzo(a)anthracene	0.0131	1.12E-03
Benzo(a)pyrene	0.0094	8.04E-04
Benzo(b)fluoranthene	0.0169	1.44E-03
Benzo(g,h,i)perylene	0.005	4.27E-04
Benzo(k)fluoranthene	0.0169	1.44E-03
Benzoic acid	0.1709	1.46E-02
Benzyl alcohol	0.0069	5.90E-04
Bis(2-ethylhexyl)phthalate	0.0449	3.84E-03

NOTES:

1. Table References/Abbreviations

- * - Leachate concentrations used are the 95th percentile upper confidence limit on the average concentration found in leachate or the maximum detected concentration if the 95th percentile upper confidence limit is greater than the maximum detected concentration.

** - Predicted Net Drainage from Base of Landfill.

*** - Regional aquifer correlates to regional water table monitored at the Site.

ND - Not Detected

(CRCCONC1.WK1)

NA - Not Analyzed

09/05/91

TABLE I-1
SUMMARY OF PREDICTED CONCENTRATIONS OF COMPOUNDS OF CONCERN
IN REGIONAL AQUIFER EXTRAPOLATED FROM LEACHATE DATA
CARDINGTON ROAD LANDFILL SITE
MORaine, OHIO

PARAMETER	LANDFILL*	PREDICTED CONCENTRATIONS
	LEACHATE CONC. (mg/l)	IN REGIONAL AQUIFER *** 4 in/yr** (mg/l)
Butylbenzylphthalate	0.0564	4.82E-03
Chrysene	0.0131	1.12E-03
Di-n-butyl-phthalate	0.0436	3.73E-03
Di-n-octylphthalate	0.0058	4.96E-04
Dibenzofuran	0.005	4.27E-04
Diethylphthalate	0.02	1.71E-03
Fluoranthene	0.025	2.14E-03
Fluorene	0.0088	7.52E-04
Indeno(1,2,3-cd)pyrene	0.005	4.27E-04
N-nitrosodiphenylamine	0.0069	5.90E-04
Naphthalene	0.0526	4.50E-03
Pentachlorophenol	0.025	2.14E-03
Phenanthrene	0.0345	2.95E-03
Phenol	0.0484	4.14E-03
Pyrene	0.0288	2.46E-03
Aluminum	317.48	2.71E+01
Arsenic	0.51	4.36E-02
Antimony	0.03	2.56E-03
Barium	12.1	1.03E+00
Beryllium	0.02	1.71E-03
Cadmium	0.24	2.05E-02
Chromium	2	1.71E-01
Cobalt	0.38	3.25E-02
Lead	6.43	5.50E-01
Mercury	0.0021	1.80E-04
Nickel	1.39	1.19E-01
Vanadium	0.63	5.39E-02
Cyanide	0.0513	4.39E-03

NOTES:

1. Table References/Abbreviations

* - Leachate concentrations used are the 95th percentile upper confidence limit on the average concentration found in leachate or the maximum detected concentration if the 95th percentile upper confidence limit is greater than the maximum detected concentration.

** - Predicted Net Drainage from Base of Landfill.

*** - Regional aquifer correlates to regional water table monitored at the Site.

ND - Not Detected

(CRCCONC1.WK1)

NA - Not Analyzed

09/05/91

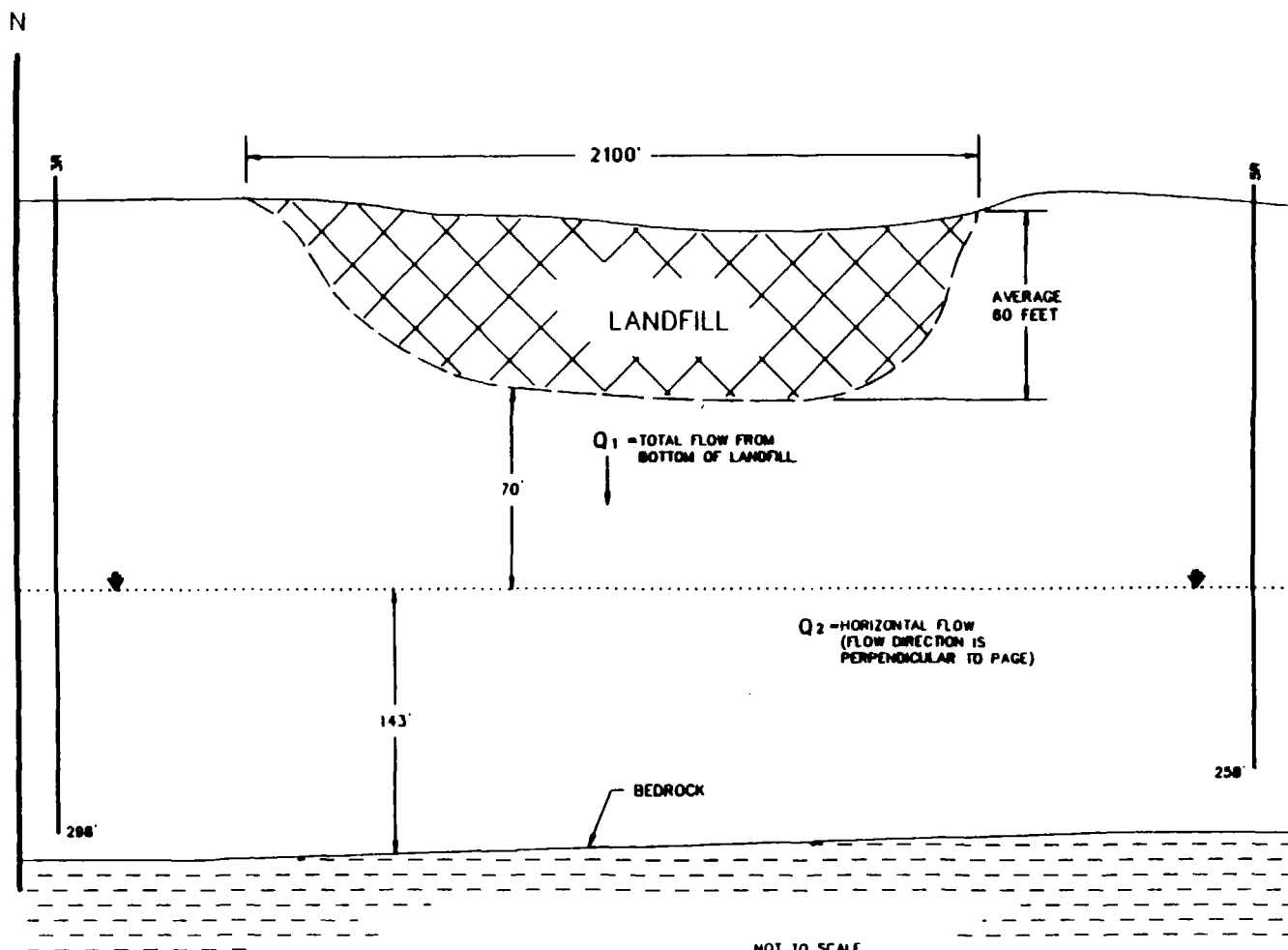

McLAREN/HART
PITTSBURGH, PENNSYLVANIA

FIGURE I-1
CONCEPTUAL ONE DIMENSIONAL MODEL COMPONENTS
CARDINGTON ROAD LANDFILL
MORaine, OHIO