



**CORRECTIVE MEASURES
IMPLEMENTATION WORK PLAN
EXCAVATED SOIL STOCKPILE AT CHOCCOLOCCO
CREEK WASTEWATER TREATMENT PLANT
ANNISTON, ALABAMA**

Solutia Inc. – Anniston Facility
USEPA I.D. No. ALD 004 019 048

Prepared for:
Alabama Department of Environmental Management
Hazardous Waste Branch
1400 Coliseum Boulevard
Montgomery, Alabama 36110-2059

Submitted by:
Solutia Inc.
702 Clydesdale Avenue
Anniston, Alabama 36201

January 2003
Revision 0

SOLUTIA

Solutions for a better life.

Solutia Inc.

702 Clydesdale Avenue

Anniston, Alabama 36201-5328

Tel/ 256-231-8400

January 16, 2003

SENT VIA FEDERAL EXPRESS

Mr. Phillip D. Davis, Chief
Industrial Hazardous Waste Branch
Land Division
Alabama Department of Environmental Management
1400 Coliseum Boulevard
Montgomery, Alabama 36130-1463

RE: CHOCOLOCCKO CREEK WASTEWATER TREATMENT PLANT
CORRECTIVE MEASURES IMPLEMENTATION WORK PLAN
SOLUTIA'S ANNISTON FACILITY
ANNISTON, ALABAMA, EPA ID NO. ALD 004 019 048

Dear Mr. Davis:

Solutia Inc. is pleased to submit this Corrective Measures Implementation Work Plan (CMI Work Plan) to address the stockpiled soil at the Choccolocco Creek Wastewater Treatment Plant. The CMI Work Plan was prepared in response to a letter from the Alabama Department of Environmental Management (ADEM) that approved the Corrective Measures Study submitted by Solutia on February 22, 2002. Solutia received the letter of approval on September 3, 2002.

Should you have any questions or require additional information regarding this CMI Work Plan, please contact me at (256) 231-8404.

Sincerely,



Craig R. Branchfield
Manager, Remedial Projects
Solutia Inc.

cc: Russ McLean, USEPA Region IV
Craig Brown, USEPA Region IV
Pam Scully, USEPA Region IV

TABLE OF CONTENTS

1.0 Introduction..... 1

2.0 Background 3

3.0 Corrective Measures Approach..... 5

4.0 Pre-Design Characterization..... 6

 4.1 Analytical Characterization Results..... 6

 4.1.1 Phase I Investigation..... 6

 4.1.2 Phase II Investigation..... 6

 4.1.3 Soil Sample Analyses and Results..... 7

 4.2 Geotechnical Characterization Results 7

5.0 Detailed Design..... 8

 5.1 General..... 8

 5.2 Incidental Excavation..... 8

 5.3 Clearing and Grubbing..... 9

 5.4 PCB-Containing Soil Embankment 9

 5.5 Cover System..... 9

 5.5.1 Flexible Membrane Liner..... 10

 5.5.2 Drainage Layer..... 10

 5.5.3 Soil Cover Layer..... 10

 5.5.4 Flood Protection Layer (Rip-rap Armor)..... 10

 5.6 Surface Water..... 11

 5.7 Erosion and Sedimentation Control 11

 5.7.1 General..... 11

 5.7.2 Temporary Stream Crossing 11

 5.8 Dust Control..... 12

 5.9 Health and Safety..... 12

 5.10 Institutional Controls 12

6.0 Cover System Maintenance Requirements..... 14

7.0 Reports and Schedule 15

8.0 Summary..... 16

IN ORDER
FOLLOWING
PAGE 16

TABLES

Table 1 – Field Screening and Laboratory Analytical Results

Table 2 – Geotechnical Characterization Results

January 2003

FIGURES

Figure 1 – Site Location Map

Figure 2 – Existing Stockpile Location

Figure 3 – Soil Sample Locations

Figure 4 – PCB Concentrations from 0 to 2 Feet Below Ground Surface

Figure 5 – PCB Concentrations from 4 to 6 Feet Below Ground Surface

Figure 6 – PCB Concentrations from 8 to 10 Feet Below Ground Surface

APPENDICES

Appendix A - Laboratory Analytical Results

Appendix B - Construction Drawings

Appendix C - Technical Specifications

Appendix D - Construction Quality Assurance Plan

Appendix E - Best Management Practices Plan

Appendix F - Spill Prevention and Pollution Control Plan

Appendix G - Dust Control Plan

Appendix H - Health and Safety Plan Template

1.0 INTRODUCTION

Solutia Inc. (Solutia) retained Golder Associates Inc. (Golder) to prepare a Corrective Measures Implementation Work Plan (CMI Work Plan) describing the proposed measures to address the management of polychlorinated biphenyl (PCB)-containing soils that were excavated and stockpiled by contractors during the expansion of the Choccolocco Creek Wastewater Treatment Plant (WWTP) on the eastern floodplain of Snow Creek. The CMI Work Plan is prepared in response to a letter from the Alabama Department of Environmental Management (ADEM) dated August 21, 2002. This letter provides approval for "Alternative No. 3" as described in the Corrective Measures Study (CMS) submitted by Solutia, dated February 22, 2002. In this letter, ADEM requested that a CMI Work Plan detailing "Alternative No. 3" be prepared and submitted within 45 days. Solutia received the letter on September 3, 2002. Solutia requested a 90-day extension to the original submittal date of October 18, 2002, in order to provide sufficient time to compile the information, (i.e. topography, floodplain analyses, and analytical and geotechnical soil characterization data) necessary to complete the final design, technical specifications, and other documents and plans necessary to implement the proposed corrective measures. ADEM approved this request in a letter to Solutia dated November 15, 2002.

The corrective measures proposed as "Alternative No. 3" involve regrading and consolidating the PCB-containing soil in the stockpile (including the soils in the temporary stockpile constructed during implementation of the Interim Measures Plan) and covering it with a low permeability cover. The reasons for regrading and consolidating the stockpile include: 1) to move the stockpile further away from the creek in order to prevent potential future bank erosion from jeopardizing the stockpile integrity; and 2) to provide an integral stockpile in order to minimize the area to be covered and to provide continuous subgrade support for the cover material. The overall objectives of the corrective measures to be implemented for management of the stockpiled soils are as follow (as stated in the CMS):

- o to minimize the potential human and ecological exposure to PCB-containing soils in the stockpile;
- o to prevent erosion and downstream transport of PCB-containing soils, both during construction and in the long term; and
- o to allow on-going use of the property for the foreseeable future.

The following sections of the CMI Work Plan provide background information (Section 2.0), the corrective measures approach (Section 3.0), the pre-design characterization results (Section 4.0), a description of the detailed design and the cover system components (Section 5.0), maintenance requirements (Section 6.0), and a proposed schedule for implementation (Section 7.0).

2.0 BACKGROUND

The WWTP is located within the incorporated limits of the City of Oxford, Alabama, on a property bound on the north by Interstate 20 and on the south by Choccolocco Creek. The property contains approximately 49 acres and is transected by Snow Creek. The WWTP facilities lie on 33 acres of this tract located to the west of Snow Creek. Figure 1 provides a Site Location Map.

The Anniston Water Works and Sewer Board (Board) is conducting a plant expansion to increase the capacity of the WWTP. The expansion includes the construction of three retention ponds; a headwork's building; an odor control scrubber unit; two grit basins; a new maintenance building; a peak flow pump station; a groundwater pumping station; and associated piping, force mains, and wash down pipes. As a result of the expansion, approximately 60,000 cubic yards of soil excavated from two of the three proposed ponds were transported and deposited in a stockpile across (east of) Snow Creek (Figure 2). The stockpile is irregular in shape and covers about 5 acres of the property. A large portion of the stockpile is located along the bank of Snow Creek, where it averages six (6) to eight (8) feet in height. A number of smaller piles, three (3) to five (5) feet high, lie further east of the creek's bank. The smaller piles were apparently the result of unloading trucks of material brought from the excavations across the creek. These small piles were not consolidated into the larger pile. The stockpiled soil is currently covered with polyethylene sheeting to reduce erosion. The stockpile is also covered with a substantial amount of vegetation.

Analytical testing of soil obtained from the stockpile indicates that the soil contains PCBs, mostly in concentrations less than 50 milligrams per kilogram (mg/kg). Construction activities related to the expansion of the WWTP were suspended by ADEM, due to National Pollutant Discharge Elimination System (NPDES) violations, before construction of Pond No. 3 began. Most of Pond No. 1, as well as Pond Nos. 2 and 3 in their entirety, lie within the 100-year floodplain of Snow Creek. Snow Creek and its floodplain are within the Area of Concern B under the RCRA Facility Investigation currently being undertaken by Solutia; therefore, ADEM requested that Solutia participate in the evaluation and implementation of corrective measures designed to manage the stockpile. Solutia prepared and submitted to ADEM a CMS presenting three alternatives for managing the soils stockpiled on the east bank of Snow Creek. As stated above, ADEM approved "Alternative No. 3", and requested Solutia to submit a CMI Work Plan detailing the

January 2003

corrective measures outlined in the CMS. This report has been prepared and is submitted in response to that request.

3.0 CORRECTIVE MEASURES APPROACH

The design and implementation of appropriate corrective measures to address the management of the PCB-containing soil stockpiled on the banks of Snow Creek involved the evaluation and consideration of appropriate objectives and alternatives. The corrective measure objectives, as well as the evaluation of three corrective measure alternatives, are presented and discussed in the CMS report dated February 22, 2002.

Based on the evaluation of the three alternatives, the approach recommended by Solutia and approved by ADEM, consists of confining and isolating the stockpiled soils and sediments on the east side of Snow Creek, including material stockpiled during prior implementation of Interim Measures at the plant. This will be accomplished by relocating and regrading the soils into an earth fill embankment and constructing a low permeability cover over the soil.

Construction of a low permeability, multi-layered cover will prevent future erosion or direct contact with the PCB-containing soils. The cover on the stockpiled material will also prevent future erosion or direct contact with the underlying *in situ* floodplain soils, which may contain PCBs. Installation of rip-rap armor on the base of the side slopes of the final cover will further provide resistance to erosion damage during possible flood events.

Implementation of the proposed sediment and erosion control procedures during the development of the project will minimize any environmental impacts from construction activities. Only minimal transport of PCB-containing soil over Snow Creek will be required. A temporary stream crossing (see Section 5.7.2) will be constructed across Snow Creek to permit access for construction equipment and to transport soils that were temporarily stockpiled during the prior implementation of Interim Measures. All work will be performed using Best Management Practices in accordance with a state-issued NPDES Permit.

January 2003

4.0 PRE-DESIGN CHARACTERIZATION

4.1 Analytical Characterization Results

Soil sampling activities to characterize the stockpiled soils at the WWTP were completed in two phases. All samples collected were analyzed for PCBs using either field screening techniques or laboratory analyses. Phase I, which consisted of an evaluation of the near surface soils only (i.e. between 0 and 2 feet below ground surface), was completed on October 3, 2002. The Phase II sampling was completed in November 2002, and provided a more thorough characterization of the stockpiled soils.

4.1.1 Phase I Investigation

The Phase I investigation was conducted between October 2 and October 3, 2002. During this investigation sample locations were selected on an approximate 60-foot grid. The sampling grid began near Snow Creek and proceeded eastward away from the WWTP facilities. At each of the 29 selected locations, one sample was collected from the surface to a depth of either 12 or 24 inches using a hand auger. All samples were screened in the field, and approximately 25 percent of the samples obtained were sent to the laboratory for confirmation analyses. The locations of the Phase I samples collected from the soil stockpile (WWSP-01 through WWSP-29) were recorded using Global Positioning System (GPS) surveying and are shown on Figure 3.

4.1.2 Phase II Investigation

The Phase II sampling event for the stockpiled soil was performed between November 11 and November 14, 2002. For the second phase of the investigation, soil samples were obtained on an approximate 30-foot grid around (and in between) the areas that had already been sampled and were determined to contain soils with PCB concentrations below 1 mg/kg. Soil sampling points WWSP-30 through WWSP-74, were completed using direct push technology (DPT) provided by Geolab Probing Services. Additionally, some depth samples were collected at the Phase I sampling points (WWSP-01 through WWSP-29). Soil samples were collected at 2-foot depth intervals from 0 to 2 feet, 4 to 6 feet, and 8 to 10 feet. All samples were screened in the field, and approximately 25 percent of the samples obtained were sent to the laboratory for confirmation analyses. The sample locations were recorded using GPS surveying. The sample locations are presented on Figure 3.

4.1.3 Soil Sample Analyses and Results

The results of PCB analyses of the soil samples are summarized in Table 1 and shown on Figures 4 through 6. The complete laboratory analytical results are included in Appendix A. All of the soil samples collected were analyzed in the field for PCBs using immunoassay techniques (USEPA Method 4020) with standards of 1 and 50 mg/kg. For confirmation analyses, selected soil samples evaluated using the immunoassay technique were submitted to STL Savannah Laboratories for PCB analysis by USEPA Method 8082.

PCB-containing soil was encountered at the surface to depths of ten feet below ground surface. As shown on Figures 4 through 6, the distribution of PCB concentrations for samples collected within the soil stockpile is as follows:

	< 1 mg/kg	1 to < 50 mg/kg	≥ 50 mg/kg
0 to 2 feet	36	31	8
4 to 6 feet	28	22	1
8 to 10 feet	7	21	1

4.2 **Geotechnical Characterization Results**

The PCB-containing soil will be placed in six (6) to eight (8) inch thick lifts, and compacted in place (as structural fill) to form an embankment. This will be done to accommodate potential future development on top of the capped soils, and the remaining property. In order to evaluate the PCB-containing soil as potential embankment fill, fifteen samples were collected for geotechnical analyses. Five samples were tested for standard classification parameters, standard Proctor testing, and *in situ* moisture content. The other ten samples were tested for *in situ* moisture content only. Each of the samples was classified as low plasticity clay based on the Unified Soil Classification System. The maximum dry density (ASTM D 698 – Standard Proctor Compaction) of the soil samples ranged from 112.5 pounds per cubic foot (pcf) to 118.2 pcf with corresponding optimum moisture contents of 16.4% and 12.3%, respectively. The *in situ* moisture content of all the soils tested ranged from 15.7% to 21.9%, averaging approximately 5% above the optimum moisture content.

5.0 DETAILED DESIGN

5.1 General

Construction activities will include regrading and consolidating the PCB-containing soil from the existing stockpile (including the soils in the temporary stockpile constructed during implementation of the Interim Measures Plan) to the location shown on Sheet 3 of the Construction Drawings (Appendix B). The relocated soil will be constructed into a compacted earth fill embankment capable of supporting light structures that may be constructed as part of future expansions at the WWTP. PCB-containing soil currently stockpiled along the Snow Creek bank will be relocated away from Snow Creek, placed in approximately 6 to 8-inch thick loose lifts, and compacted in place. The earth fill embankment will be covered with a multi-layer cover to permanently contain the PCB-containing soil material. Rip-rap armor will be installed at the base of the side slopes of the final cover to further provide resistance to erosion damage during possible flood events.

The earth fill embankment will cover an area of approximately 5 acres, and will be built to an average height of about nine (9) feet not including the final cover system. Technical specifications for the project are included in Appendix C. Any additional excavated material will be managed according to Section 5.2. The components of the multi-layer cover system proposed to contain the embankment soil are described in Section 5.5 and shown on Sheet 6 of the Construction Drawings. At the end of construction, the PCB-containing soils will be effectively isolated beneath the cover system.

Erosion and sedimentation controls as described in Section 5.7 will be used to address migration of sediment from the area during construction.

A Construction Quality Assurance Plan for this project is included in Appendix D.

5.2 Incidental Excavation

To the extent practical, excavation below the original ground surface (*in situ* soils) will be minimized. However, some incidental excavation will be required for providing drainage, to install erosion control measures, and to key the rip-rap armor into the existing ground surface.

All required excavation will be performed prior to the completion of the cover system. All material excavated will be incorporated into the embankment area to be covered.

5.3 Clearing and Grubbing

Trees, bushes, and vegetation removal will be required both on the existing stockpile and on the proposed location for the earth fill embankment. The clearing will be performed prior to beginning the regrading of the stockpile. The trees will be cut down at ground surface, and the stumps and roots will be removed. The trees, stumps and roots will be disposed of in accordance with the applicable laws and regulations governing the handling of landscape debris. All soil will be removed from the stumps and roots prior to disposal.

and this means what?

5.4 PCB-Containing Soil Embankment

The existing material in the PCB-containing soil stockpile will be relocated away from Snow Creek, placed and compacted by heavy equipment to the approximate elevations shown on Sheet 3 of the Construction Drawings. The stockpiled soil will be removed to the ground elevation that existed prior to the soil being hauled and placed on the east bank of Snow Creek. The original ground elevation will be determined by the exposure of a continuous layer of organic material.

The final elevation of the embankment may be adjusted (up or down) in the field in order to accommodate the actual quantity of PCB-containing material encountered. However, a minimum slope of 2% shall be maintained on the top of the cover.

OK

The PCB-containing soil within the embankment will be placed in six (6) to eight (8)-inch thick lifts and compacted to 95 percent of the maximum dry density as measured by Standard Proctor (ASTM D698). Placement and compaction procedures are described in Section 02221 of the Technical Specifications, included in Appendix C.

5.5 Cover System

The lowermost cover component of the stockpile cover system will be a flexible membrane liner (FML). A geosynthetic drainage layer will be placed on top of the FML. The final cover layer will be two (2) feet thick, and will consist of approximately 18 inches of soil and six (6) inches of topsoil.

source ?

5.5.1 Flexible Membrane Liner

no geotextile puncture potential

The FML will consist of a 40-mil high-density polyethylene (HDPE) geomembrane. It will be installed immediately above, and in direct contact with the compacted and graded earth fill material. The FML will extend across the top and down the side slopes of the cover and will be anchored underneath a proposed toe drain (see Section 5.5.2). A qualified installer, in accordance with strict specifications, will install the FML. Additionally, qualified personnel will monitor the installation of the liner system.

maybe OK

5.5.2 Drainage Layer

The drainage layer will consist of geosynthetic drainage material placed directly on the FML. The geosynthetic drainage material will consist of a one-sided geocomposite and have an equivalent hydraulic conductivity of 2 centimeters per second (cm/sec) or greater under the anticipated soil cover loads.

compatible with cover soil crossing analysis

The drainage layer will day-light at the toe of the slope above a gravel toe drain. The toe drain will consist of No. 57 stone that will lie immediately underneath of, and in contact with, the riprap armor to be installed for flood protection (see Section 5.5.4). This will provide drainage and minimize any hydraulic head at the toe drain, which could potentially cause instability in the cover system.

5.5.3 Soil Cover Layer

A soil cover layer will be placed on top of the drainage layer. The soil layer will be approximately 18 inches thick, and will extend across the proposed cover area to protect the geosynthetic components of the cover system. Along the top portion of the cover system and above elevation 610 feet mean sea level (ft-MSL) on the sideslopes (Sheet 6 of the Construction Drawings), a 6-inch layer of topsoil will be added to provide support for vegetation. The soil cover layer and topsoil will be tested prior to transporting the material on site to ensure that the soils have PCB concentrations less than 1 mg/kg.

OK

5.5.4 Flood Protection Layer (Rip-rap Armor)

The recompacted earth fill embankment will be located within the 100-year floodplain of Snow and Choccolocco Creeks. To protect the stockpile from potential flood damage, a rip-rap armor

will be constructed from the toe of the side slopes to elevation 610 ft-MSL (approximately 2 feet above the 100-year flood elevation).

5.6 Surface Water

Currently, surface water runoff is directed through sheet flow towards the south and southwest, mostly towards Choccolocco Creek. There is a concrete lined channel that discharges runoff to the property on the northeast corner of the site.

The proposed design will not impact most of the flow patterns within the property. The northern limits of the stockpile embankment will naturally drain both east and west, and form a channel with the rip-rap armor located on the side slope. In addition, the stockpile will be located so as not to interfere with the flow from the concrete channel in the northeast corner of the site.

5.7 Erosion and Sedimentation Control

5.7.1 General

The relocation, placement, and subsequent covering of the PCB-containing soils will isolate the material from future contact and prevent the migration of sediment. Additionally, potential impacts from downstream transport of fugitive sediment during construction will be mitigated by the use of effective erosion and sedimentation controls. The proposed sediment and erosion control measures are shown on Sheets 5 and 7 of the Construction Drawings. A Best Management Practices Plan (BMP) and a Spill Prevention Control and Countermeasures Plan (SPCC) were prepared as part of this detailed design (Appendix E and F). Additionally, as required by ADEM regulations, a NPDES General Construction Storm Water Permit will be obtained.

5.7.2 Temporary Stream Crossing

The use of a bridge to cross Snow Creek during construction is the preferred method for temporary access to the east portion of the site. Normally, bridge construction causes the least disturbance to the creek bed and banks when compared to culverts. Construction, use, and/or removal of a temporary access bridge will typically not affect the stream or its banks. Temporary bridges can be constructed from wood and logs, used railroad cars (flatcars and boxcars are usually 85 feet in length), truck flat beds (about 60 feet in length), portable hinged bridges,

modular steel bridges (made of interlocking panels), and prestressed concrete panels (can often be purchased used from the Department of Transportation).

Specifications for installation of a temporary bridge crossing for construction equipment and personnel access across Snow Creek are included in Appendix C. However, the Board has expressed an interest in installing a permanent crossing to access the eastern portion of the property. Solutia will cooperate with the Board should they elect to have a permanent structure built before the project starts.

5.8 Dust Control

During implementation of the corrective measures, dust from construction activities will be minimized to the extent practical. A Dust Control Plan has been developed for the site during the detailed design to describe the strategies for controlling the release of dust from the construction activities (Appendix G). Throughout construction, dust control measures will be implemented and monitoring will be performed.

5.9 Health and Safety

A Health and Safety Plan (HASP) template for this project is included in Appendix H. The HASP provides the minimum guidelines that the contractor must follow during execution of the work. Prior to beginning work at the site, the selected contractor to perform the work will be required to develop a site specific HASP to be implemented during the corrective measures. The HASP will be developed in accordance with requirements set forth in 29 CFR 1910.120 and the activities proposed to complete the project. Identification of the project team, required training and responsibilities of each team member and of site workers will be detailed in the Contractor's HASP. Emergency response procedures will be identified along with procedures for air monitoring, personal protective equipment, decontamination, and for specific tasks that are planned.

5.10 Institutional Controls

Upon completion of construction activities and submission of the Final CMI Report, a survey plat indicating the location and dimensions of the capped stockpile with respect to permanently surveyed benchmarks will be submitted to the local zoning authority and to ADEM. The plat will

January 2003

be prepared by a professional land surveyor registered in the state of Alabama and will contain a note that states the obligation to limit the property to specified non-residential uses.

With submission of the plat, the Board will place a notation on the property deed, in accordance with State law, that the property has PCB-containing soils within the covered embankment. Consequently, access and future construction activities will be limited and controlled by the Board.

January 2003

6.0 COVER SYSTEM MAINTENANCE REQUIREMENTS

The cover system will be inspected on a semi-annual interval and following significant storm events (greater than 3 inches in 24 hours) to observe the condition of the cover system and slopes. The area will be inspected for cover and slope conditions such as settlement, erosion, cracking, and bare spots. The structural integrity of the cover system will be evaluated during each inspection. Mowing and fertilization needs will also be evaluated. The inspection will be recorded on an appropriate Inspection Log. The inspector will record any needed repairs identified during the inspection.

Periodic maintenance will be required to maintain the integrity of the cover system. Mowing and fertilizing will be done, if required. Areas or items requiring attention or repair will be clearly identified. Properly trained and qualified personnel will complete the necessary repairs. The Inspection Log sheets will include sections for tracking repairs or action items completed. Inspection log sheets will be recorded and maintained for a period of ten years in a central file location.

7.0 REPORTS AND SCHEDULE

The estimated schedule for construction of the covered earth fill embankment on the east side of Snow Creek is as follows:

TASK	SCHEDULED DATE
Submit CMI Work Plan with Final Design, Technical Specifications, BMP Plan, SPCC Plan, etc.	January 17, 2003
Solicit and Review Bids	60 Days after ADEM approves modification to Solutia's Hazardous Waste Treatment and Storage Permit.
Award Contract	90 Days after ADEM approves modification to Solutia's Hazardous Waste Treatment and Storage Permit.
Mobilize to Site	135 Days after ADEM approves modification to Solutia's Hazardous Waste Treatment and Storage Permit.
Complete Construction Activities	350 Days after ADEM approves modification to Solutia's Hazardous Waste Treatment and Storage Permit.

This schedule is based on the timely approval of other permits required for construction. Solutia is currently applying for a Request for Jurisdictional Determination from the Army Corps of Engineers, a potential map revision request from the Federal Emergency Management Agency (FEMA), and an NPDES permit from ADEM.

The schedule may be modified if the Board elects to have a permanent bridge constructed across Snow Creek, or to take into account the weather conditions at the time construction is to take place.

During construction, progress reports will be submitted to ADEM on a quarterly basis. The progress reports will include a description of work completed, a summary of deviations from the approved CMI Work Plan, a summary of potential problems along with proposed solutions, a summary of data collected during the reporting period, and a description of projected work for the next period. A Final CMI Report will be submitted upon completion of construction activities.

8.0 SUMMARY

The relocation and placement of the PCB-containing soil from the existing stockpile and construction of a multi-layer cover system will minimize the potential long-term risk of human and ecological exposure to the materials, prevent erosion and downstream transport of the materials, and allow the on-going use of the property for the foreseeable future. Additionally, the use of BMPs during construction will minimize the migration of impacted soil during implementation of the corrective measures.



Jan. 16, 2003

Table 1
Field Screening and Laboratory Analytical Results for Soil Samples Collected
at the Anniston Wastewater Treatment Plant, Anniston, Alabama.

Sample ID	Sample Depth	Date Sampled	Sample Description	Sample Color	Dry Weight %	Screening Level	Polychlorinated Biphenyls (mg/kg dw)												
							USEPA Method 8082												
							Aroclor 1016	Aroclor 1221	Aroclor 1232	Aroclor 1242	Aroclor 1248	Aroclor 1254	Aroclor 1260	Aroclor 1268	Total PCBs				
WWSP-01	(0-1')	10/2/02	ML	Dark Brown		>50													
WWSP-02	(0-1')	10/2/02	ML	Dark Brown		>50													
WWSP-03	(0-2')	10/2/02	CL	Red Brown	82	<1	<0.040	<0.082	<0.040	<0.040	<0.040	<0.040	<0.040	<0.040	BDL				
	(4-6')	11/14/02				>1													
	(8-10')	11/14/02				>1													
WWSP-04	(0-2')	10/2/02	ML / CL	Yellow Brown		>1													
WWSP-05	(0-2')	10/2/02	CL	Red Brown		>1													
WWSP-06	(0-1')	10/2/02	CL	Light Brown		>50													
WWSP-07	(0-1')	10/2/02	CL	Light Brown	81	>1	<0.041 UJ	<0.083 UJ	<0.041 UJ	0.12 J	<0.041 UJ	0.16 J	0.10 J	0.044 J	0.42 J				
	(4-6')	11/14/02				>1													
	(8-10')	11/14/02			81	>1	<0.041 UJ	<0.083 UJ	<0.041 UJ	0.30 J	0.64 J	0.46 J	0.11 J	1.5 J					
WWSP-08	(0-1')	10/2/02	CL	Light Brown		>1													
WWSP-09	(0-1')	10/2/02	MH	Yellow Brown		>1													
WWSP-10	(0-1')	10/2/02	MH	Light Brown		>1													
WWSP-11	(0-2')	10/2/02	MH	Light Brown		>1													
WWSP-12	(0-2')	10/2/02	MH	Light Brown	86	>1	<0.077	<0.16	1.9	<0.077	0.98	0.54	0.76	0.24	4.4				
WWSP-13	(0-2')	10/2/02	MH	Light Brown	87	>1	<0.038	<0.077	<0.038	0.30	0.45	0.45	0.45	0.14	1.3				

Table 1
 Field Screening and Laboratory Analytical Results for Soil Samples Collected
 at the Anniston Wastewater Treatment Plant, Anniston, Alabama.

Sample ID	Sample Depth	Date Sampled	Sample Description	Sample Color	Dry Weight %	Screening Level	Polychlorinated Biphenyls (mg/kg dw)									
							Aroclor 1016	Aroclor 1221	Aroclor 1232	Aroclor 1242	Aroclor 1248	Aroclor 1254	Aroclor 1260	Aroclor 1268	Total PCBs	
WWSP-24	(0-2')	10/3/02	ML / CL	Dark Brown	84	>1	<0.039	<0.080	<0.039	<0.039	0.055 J	0.23	0.23	0.062	0.58 J	
	(4-6')	11/13/02			78	>1	<0.042	<0.086	<0.042	<0.042	0.16	0.51	0.29 J	0.13	1.1 J	
	(8-10')	11/13/02				>1										
WWSP-25	(0-2')	10/3/02	ML	Red Brown	85	>1	<0.039	<0.079	<0.039	<0.039	0.30	0.49	0.48	0.12	1.4	
WWSP-26	(0-1')	10/3/02	ML / CL	Dark Brown		>50										
DUP	(0-1')	10/3/02	ML / CL	Dark Brown		>50										
WWSP-27	(0-1')	10/3/02	ML / CL	Dark Brown		>1										
WWSP-28	(0-1')	10/3/02	CL	Light Brown	89	<1	<0.037	<0.075	<0.037	<0.037	<0.037	<0.037	<0.037	<0.037	BDL	
WWSP-29	(0-1')	10/3/02	CL	Light Brown	81	>1	<0.041	<0.083	<0.041	<0.041	0.19	0.22	0.21	0.054	0.67	
WWSP-30	(0-2')	11/11/02				<1										
	(4-6')	11/11/02				<1										
WWSP-31	(0-2')	11/11/02				<1										
	(4-6')	11/11/02				<1										
WWSP-32	(0-2')	11/11/02				>1										
	(4-6')	11/11/02				>1										
WWSP-33	(0-2')	11/11/02			83	<1	<0.040	<0.081	<0.040	<0.040	<0.040	0.091	0.073	<0.040	0.16	
	(4-6')	11/11/02				<1										

Table 1
 Field Screening and Laboratory Analytical Results for Soil Samples Collected
 at the Anniston Wastewater Treatment Plant, Anniston, Alabama.

Sample ID	Sample Depth	Date Sampled	Sample Description	Sample Color	Dry Weight %	Screening Level	Polychlorinated Biphenyls (mg/kg dw)															
							1016	1221	1232	1242	1248	1254	1260	1268	Total PCBs							
WWSP-34	(0-2')	11/11/02				>50																
	(4-6')	11/11/02				>1																
DUP	(4-6')	11/11/02				>1																
	(8-10')	11/11/02				>1																
WWSP-35	(0-2')	11/11/02				>1																
	(4-6')	11/11/02				>1																
	(8-10')	11/11/02				>1																
WWSP-36	(0-2')	11/11/02				<1																
	(4-6')	11/11/02				>1																
	(8-10')	11/11/02				>1																
WWSP-37	(0-2')	11/11/02				<1																
	(4-6')	11/11/02				<1																
	(8-10')	11/11/02				>1																
WWSP-38	(0-2')	11/11/02				<1																
	(4-6')	11/11/02				<1																
	(8-10')	11/11/02				<1																
WWSP-39	(0-2')	11/12/02			84	>1	<0.039	<0.080	<0.039	<0.039	<0.039	<0.039	<0.039	<0.039	0.16	0.10	<0.039	<0.039	<0.039	<0.039	0.26	
	(4-6')	11/12/02				<1																
	(8-10')	11/12/02				<1																
WWSP-40	(0-2')	11/14/02				<1																
	(4-5')	11/14/02				<1																
WWSP-41	(0-2')	11/12/02				>1																
	(4-6')	11/12/02			82	<1	<0.040	<0.082	<0.040	<0.040	<0.040	<0.040	0.071	0.12	0.12	0.12	<0.040	<0.040	<0.040	<0.040	0.31	
	(8-10')	11/12/02				>1																

Table 1
 Field Screening and Laboratory Analytical Results for Soil Samples Collected
 at the Anniston Wastewater Treatment Plant, Anniston, Alabama.

Sample ID	Sample Depth	Date Sampled	Sample Description	Sample Color	Dry Weight %	Screening Level	Polychlorinated Biphenyls (mg/kg dw)										
							1016	1221	1232	1242	1248	1254	1260	1268	Total PCBs		
WWSP-42	(0-2')	11/12/02			87	>1	<0.038	<0.077	<0.038	<0.038	<0.038	<0.038	0.54	0.69	0.53	0.13	1.9
	(4-6')	11/12/02				<1											
	(8-10')	11/12/02				>50											
DUP	(8-10')	11/12/02				>1											
WWSP-43	(0-2')	11/12/02				>1											
	(4-6')	11/12/02				>1											
	(8-10')	11/12/02				>1											
WWSP-44	(0-2')	11/13/02			85	>1	<0.039	<0.079	<0.039	<0.039	<0.039	0.21	0.53	0.43	0.089	1.3	
	(4-6')	11/13/02				>1											
WWSP-45	(0-2')	11/14/02				>50											
WWSP-46	(0-2')	11/14/02			86	>1	<0.038	<0.078	<0.038	<0.038	<0.038	0.11 J	0.81	0.69	0.18	1.8 J	
WWSP-47	(0-2')	11/13/02			83	<1	<0.040	<0.081	<0.040	<0.040	<0.040	0.076	0.36	0.24	0.061	0.74	
DUP	(0-2')	11/13/02			82	>1	<0.040	<0.082	<0.040	<0.040	<0.040	0.052 J	0.32	0.21	0.049	0.63 J	
	(4-6')	11/13/02				>1											
WWSP-48	(0-2')	11/13/02				<1											
WWSP-49	(0-2')	11/13/02				<1											
	(4-6')	11/13/02				<1											
	(8-10')	11/13/02			78	<1	<0.042	<0.086	<0.042	<0.042	<0.042	<0.042	<0.042	<0.042	<0.042	BDL	
WWSP-50	(0-2')	11/12/02			83	>1	<0.040	<0.081	<0.040	<0.040	<0.040	0.075 J	0.31	0.23	0.056	0.67 J	
	(4-6')	11/12/02			83	>1	<0.040	<0.081	<0.040	<0.040	<0.040	0.26	0.30	0.23	0.060	0.85	
	(8-10')	11/12/02				<1											

Table 1
 Field Screening and Laboratory Analytical Results for Soil Samples Collected
 at the Anniston Wastewater Treatment Plant, Anniston, Alabama.

Sample ID	Sample Depth	Date Sampled	Sample Description	Sample Color	Dry Weight %	Screening Level	Polychlorinated Biphenyls (mg/kg dw)															
							Aroclor 1016	Aroclor 1221	Aroclor 1232	Aroclor 1242	Aroclor 1248	Aroclor 1254	Aroclor 1260	Aroclor 1268	Total PCBs							
WWSP-51	(0-2')	11/13/02			89	>1	<0.037	<0.075	<0.037	<0.037	<0.037	<0.037	<0.037	<0.037	<0.037	<0.037	<0.037	0.20	0.18	0.050	0.43	
	(4-6')	11/13/02			79	>1	<0.042	<0.085	<0.042	<0.042	<0.042	<0.042	<0.042	<0.042	<0.042	<0.042	<0.042	0.36	0.25	0.062	0.73 J	
WWSP-52	(0-2')	11/13/02				>1																
	(4-6')	11/13/02				<1																
	(8-10')	11/13/02				>1																
WWSP-53	(0-2')	11/13/02				<1																
	(4-6')	11/13/02				>1																
	(8-10')	11/13/02				>1																
WWSP-54	(0-2')	11/13/02				<1																
	(4-6')	11/13/02				<1																
	(8-10')	11/13/02				>1																
WWSP-55	(0-2')	11/13/02				>50																
	(4-6')	11/13/02				>1																
WWSP-56	(0-2')	11/13/02				>1																
WWSP-57	(0-2')	11/12/02			85	>1	<0.039 UJ	<0.079 UJ	<0.039 UJ	<0.039 UJ	<0.039 UJ	<0.039 UJ	<0.039 UJ	<0.039 UJ	<0.039 UJ	<0.039 UJ	<0.039 UJ	0.44 J	0.40 J	0.096 J	1.1 J	
	(4-6')	11/12/02				>1																
WWSP-58 DUP	(0-2')	11/12/02				<1																
	(0-2')	11/12/02				<1																
	(4-6')	11/12/02			83	<1	<0.040	<0.081	<0.040	<0.040	<0.040	<0.040	<0.040	<0.040	<0.040	<0.040	<0.040	0.13	0.11	<0.040	0.29	
WWSP-59	(0-2')	11/12/02				<1																
	(4-5')	11/12/02				<1																

Table 1
 Field Screening and Laboratory Analytical Results for Soil Samples Collected
 at the Anniston Wastewater Treatment Plant, Anniston, Alabama.

Sample ID	Sample Depth	Date Sampled	Sample Description	Sample Color	Dry Weight %	Screening Level	Polychlorinated Biphenyls (mg/kg dw)										Total PCBs							
							1016 Aroclor	1221 Aroclor	1232 Aroclor	1242 Aroclor	1248 Aroclor	1254 Aroclor	1260 Aroclor	1268 Aroclor	USEPA Method 8082									
WWSP-60	(0-2)	11/12/02				<1																		
	(4-6)	11/12/02				<1																		
	(7-9)	11/12/02			80	>1	<0.041	<0.084	<0.041	<0.041	<0.041	<0.041	0.089	0.15	0.12	<0.041								0.36
WWSP-61	(0-2)	11/12/02				>1																		
	(4-6)	11/12/02			82	>1	<0.040	<0.082	<0.040	<0.040	<0.040	<0.040	0.062	0.057	<0.040									0.12
	(8-10')	11/12/02				>1																		
WWSP-62	(0-2)	11/12/02				<1																		
	(4-6)	11/12/02				<1																		
	(8-10')	11/12/02				>1																		
WWSP-63	(0-2)	11/12/02				>1																		
	(4-6)	11/12/02				<1																		
	(8-10')	11/12/02				<1																		
WWSP-64	(0-2)	11/12/02			83	>1	<0.040	<0.081	<0.040	<0.040	<0.040	0.094	0.18	0.16	0.046									0.48
	(4-6)	11/12/02				<1																		
WWSP-65	(0-2)	11/14/02				<1																		
	(4-6)	11/14/02				<1																		
WWSP-66	(0-2)	11/14/02				>1																		
	(4-6)	11/14/02				>1																		
WWSP-67	(0-2)	11/14/02				>1																		
	(4-6)	11/14/02				>1																		
WWSP-68	(0-2)	11/13/02				<1																		
	(4-6)	11/13/02				>1																		
	(8-10')	11/13/02				>1																		

Table 1
 Field Screening and Laboratory Analytical Results for Soil Samples Collected
 at the Anniston Wastewater Treatment Plant, Anniston, Alabama.

Sample ID	Sample Depth	Date Sampled	Sample Description	Sample Color	Dry Weight %	Screening Level	Polychlorinated Biphenyls (mg/kg dw)													
							1016	1221	1232	1242	1248	1254	1260	1268	Total PCBs					
WWSP-69	(0-2')	11/13/02				>1														
	(4-6')	11/13/02			83	>1	<0.040	<0.081	<0.040	<0.040	0.22	0.58 J	0.44 J	0.12	1.4 J					
DUP	(4-6')	11/13/02			82	>1	<0.040 UJ	<0.082 UJ	<0.040 UJ	<0.040 UJ	0.18 J	0.85 J	0.64 J	0.17 J	1.8 J					
	(8-10')	11/13/02				>1														
WWSP-70	(0-2')	11/13/02				>1														
	(4-6')	11/13/02				<1														
WWSP-71	(0-2')	11/14/02				<1														
	(4-6')	11/14/02			83	<1	<0.040	<0.081	<0.040	<0.040	<0.040	0.11	0.089	<0.040	0.20					
	(8-10')	11/14/02				>1														
WWSP-72	(0-2')	11/14/02				<1														
	(4-6')	11/14/02			80	>1	<0.041 UJ	<0.084 UJ	<0.041 UJ	<0.041 UJ	<0.041 UJ	0.13 J	0.090 J	<0.041 UJ	0.22 J					
	(8-10')	11/14/02				>1														
WWSP-73	(0-2')	11/14/02			80	>1	<0.041	<0.084	<0.041	<0.041	0.33	0.50	0.37	0.084	1.3					
	(4-6')	11/14/02			81	>1	<0.041	<0.083	<0.041	<0.041	0.41	0.38	0.25	0.060	1.1					
WWSP-74	(0-2')	11/14/02				>1														
	(4-6')	11/14/02				>50														
DUP	(4-6')	11/14/02				>50														
	(8-10')	11/14/02				>1														

ABBREVIATIONS:

- ML = Inorganic silts and very fine sands, rock flour, silty or clayey fine sands, or clayey silts, with slight plasticity.
- CL = Inorganic clays of low to medium plasticity, gravelly clays, sandy clays, silty clays, lean clays.
- MH = Inorganic silts, micaceous or diatomaceous fine sandy soils, elastic silts.
- J = Value is qualified as estimated.
- UJ = Non-Detect value is qualified as estimated.

Table 2
Geotechnical Characterization Results for Soil Samples
Collected at the Anniston Wastewater Treatment Plant, Anniston, Alabama

Sample Identification	Sample Type	Sample Depth	Soil Classification	Natural MC %	Atterberg Limits				Grain Size Distribution			Compaction		Unit Weight		Permeability (cm/sec)	Comments
					LL	PL	PI	LI	% Finer No. 4 Sieve	% Finer No. 200 Sieve	% Finer .005 mm	Maximum Dry Density pcf	Optimum MC %	MC %	Dry pcf		
WWSP-3	Bulk	Surface	CL	21.9	34	18	15	-	97.7	72.3	-	112.5	16.4	-	-	-	-
WWSP-7	Bulk	Surface	CL	21.8	31	17	14	-	94.8	59.1	-	115.0	14.4	-	-	-	-
WWSP-14	Bulk	Surface	CL	17.6	28	19	9	-	96.3	51.0	-	118.2	12.3	-	-	-	-
WWSP-20	Bulk	Surface	CL	18.7	32	18	14	-	98.6	72.3	-	112.8	14.4	-	-	-	-
WWSP-22	Bulk	Surface	CL-ML	17.0	24	17	7	-	97.4	65.2	-	117.0	12.9	-	-	-	-
WWSP-14	Jar	4 - 6'	CL	19.6	-	-	-	-	-	-	-	-	-	-	-	-	-
WWSP-22	Jar	8 - 10'	CL	21.0	-	-	-	-	-	-	-	-	-	-	-	-	-
WWSP-38	Jar	0 - 2'	CL	17.8	-	-	-	-	-	-	-	-	-	-	-	-	-
WWSP-41	Jar	4 - 6'	CL	21.1	-	-	-	-	-	-	-	-	-	-	-	-	-
WWSP-49	Jar	4 - 6'	CL	21.1	-	-	-	-	-	-	-	-	-	-	-	-	-
WWSP-54	Jar	0 - 2'	CL	19.5	-	-	-	-	-	-	-	-	-	-	-	-	-
WWSP-55	Jar	4 - 6'	CL	15.7	-	-	-	-	-	-	-	-	-	-	-	-	-
WWSP-63	Jar	4 - 6'	CL	16.4	-	-	-	-	-	-	-	-	-	-	-	-	-
WWSP-68	Jar	0 - 2'	CL	18.6	-	-	-	-	-	-	-	-	-	-	-	-	-
WWSP-71	Jar	4 - 6'	CL	19.6	-	-	-	-	-	-	-	-	-	-	-	-	-

ABBREVIATIONS:

- LL = Liquid Limit
- PL = Plastic Limit
- PI = Plasticity Index
- LI = Liquidity Index
- Gs = Specific Gravity
- MC = Moisture Content
- CL = Silty Clay
- CL-ML = Silty Clay to Clayey Silt

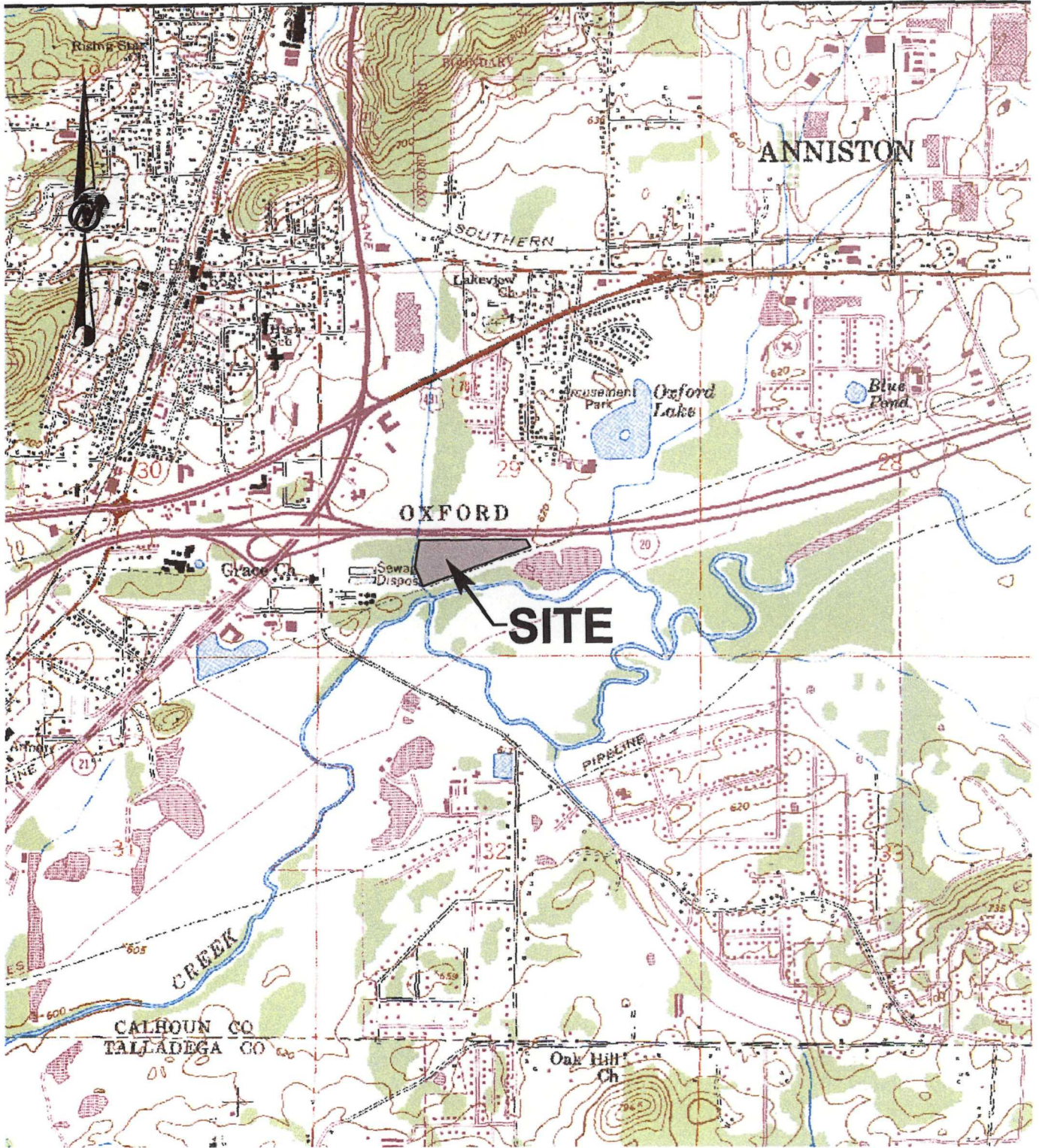

Drawing file: 9433680WTPCHAR06.dwg Jan 15, 2003 - 9:27am

REF: USGS 7.5 MINUTE
OXFORD QUADRANGLE

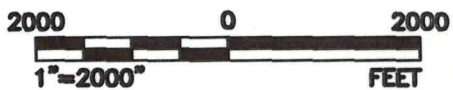

REV	DATE	DES	REVISION DESCRIPTION	CADD	CHK	RWW
PROJECT			SOLUTIA INCORPORATED CHOCOLOCCO CREEK WWTP ANNISTON, ALABAMA			
TITLE			SITE LOCATION MAP			
PROJECT No.		934-3680	FILE No.		9433680WTPCHAR06	
DESIGN	-	-	SCALE		AS SHOWN	
CADD	RMS	01/03	REV.		-	
CHECK	CMM	01/03	1		-	
REVIEW	SJM	01/03				



INTERSTATE 20

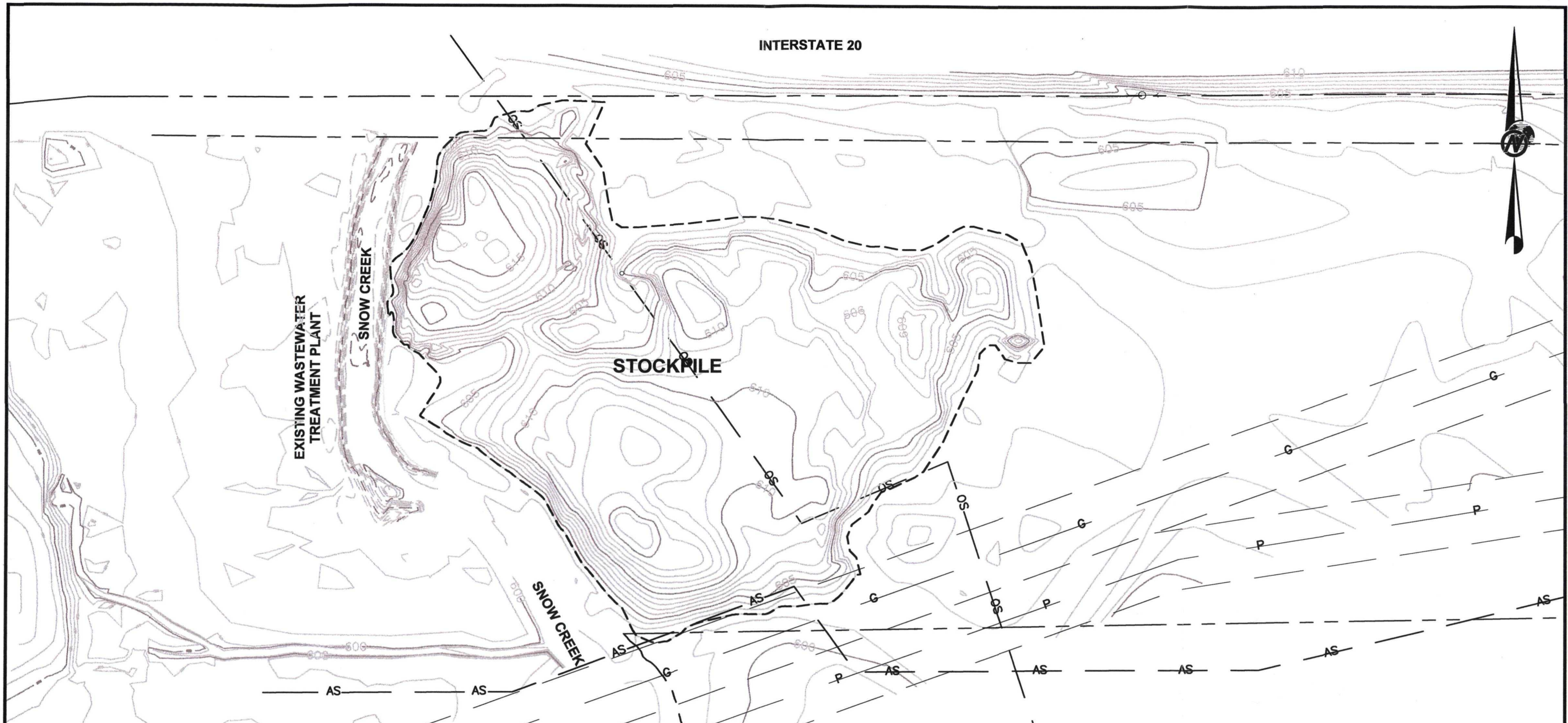

LEGEND

- PROPERTY BOUNDARY AND/OR RIGHT-OF-WAY
- 605 EXISTING CONTOURS
- G EXISTING GAS MAIN
- P EXISTING POWERLINE
- OS AS EXISTING SANITARY SEWER
(OS-CITY OF OXFORD/
AS-CITY OF ANNISTON)
- APPROXIMATE LIMITS OF EXISTING
PCB-CONTAINING STOCKPILE

REFERENCES

- 1) EXISTING TOPOGRAPHY EAST OF SNOW CREEK PROVIDED BY MAXWELL SURVEYING, INC. DATED NOVEMBER, 2002.
- 2) EXISTING TOPOGRAPHY WITHIN SNOW CREEK AND TO THE WEST OF SNOW CREEK, PROPERTY BOUNDARY, EXISTING UTILITIES AND EASEMENTS PROVIDED BY KREBS ENGINEERING, INC.

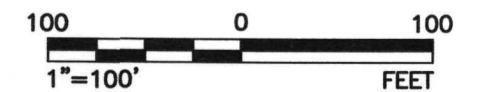

REV	DATE	DES	REVISION DESCRIPTION	CADD	CHK	RW
-	-	-	-	-	-	-
PROJECT: SOLUTIA INC. CHOCCOLOCCO CREEK WWTP ANNISTON, ALABAMA						
TITLE: EXISTING STOCKPILE LOCATION						
PROJECT No. 943-3680		FILE No. 9433690WTPCHAR01		SCALE AS SHOWN REV. -		
DESIGN	-	-	-	2		
CADD	GM	12/02	-			
CHECK	CMM	01/03	-			
REVIEW	SJM	01/03	-			



Drawing file: 9433690WTPCHAR01.dwg Jan 15, 2003 - 9:31am

Drawing file: 9433690WTPCHAR02.dwg Jan 15, 2003 - 10:22am

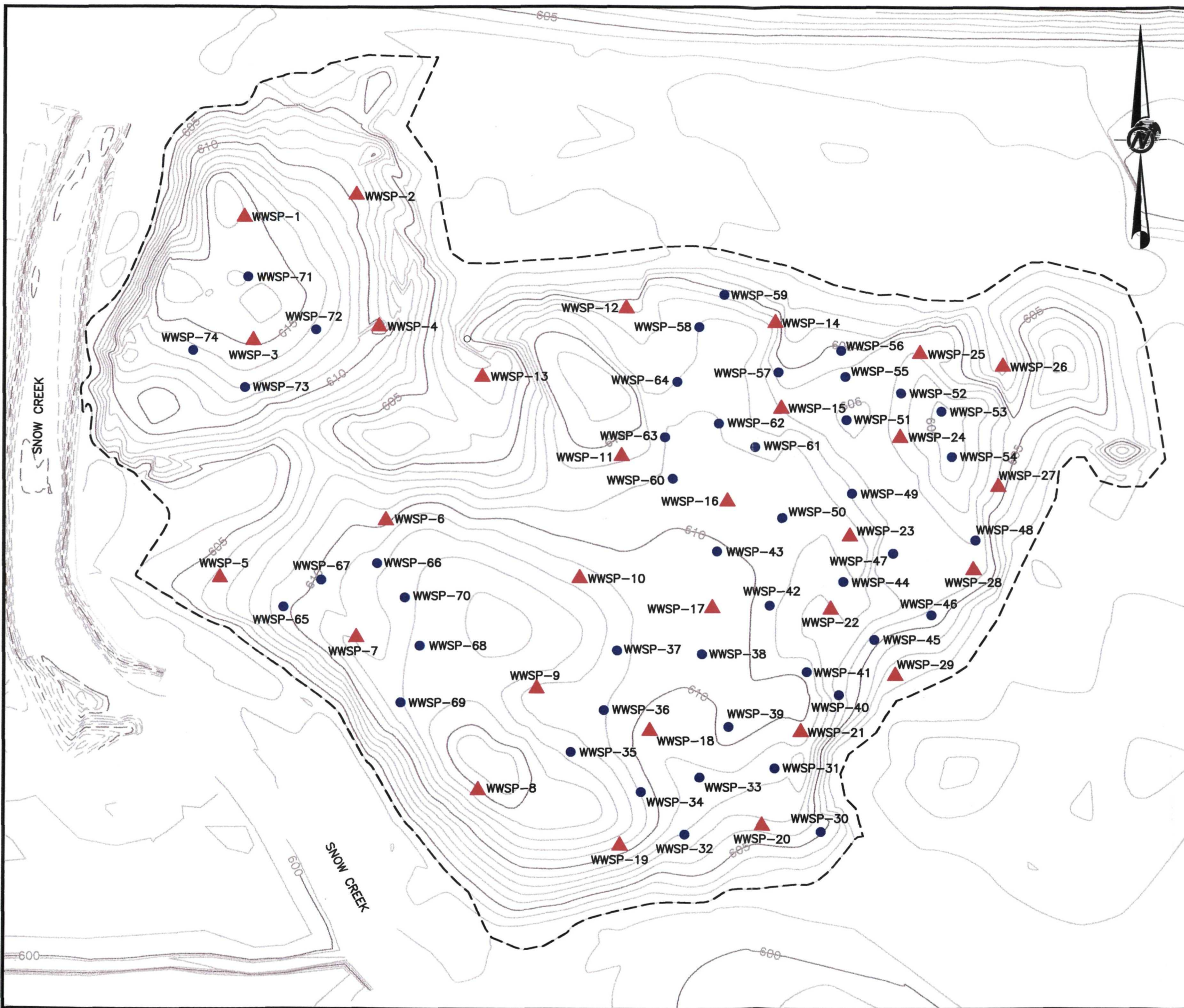

LEGEND

- ▲ WWSP-15 PHASE I SAMPLE LOCATIONS
- WWSP-71 PHASE II SAMPLE LOCATIONS
- 605 — EXISTING CONTOURS
- - - - - APPROXIMATE LIMITS OF EXISTING PCB-CONTAINING STOCKPILE

NOTES

1) SAMPLE LOCATIONS AND RESULTS PROVIDED BY GENESIS PROJECT, INC.

REFERENCES

1) EXISTING TOPOGRAPHY EAST OF SNOW CREEK PROVIDED BY MAXWELL SURVEYING, INC. DATED NOVEMBER, 2002.

2) EXISTING TOPOGRAPHY WITHIN SNOW CREEK AND TO THE WEST OF SNOW CREEK, PROPERTY BOUNDARY, EXISTING UTILITIES AND EASEMENTS PROVIDED BY KREBS ENGINEERING, INC.



REV	DATE	DES	REVISION DESCRIPTION	CADD	CHK	RW
PROJECT: SOLUTIA INC. CHOCOLOCICO CREEK WWTP ANNISTON, ALABAMA						
TITLE: SOIL SAMPLE LOCATIONS						
PROJECT No. 943-3680		FILE No. 9433690WTPCHAR02		SCALE AS SHOWN REV. -		
DESIGN	-	-				
CADD	GM	12/02				
CHECK	CMM	01/03				
REVIEW	SJM	01/03				
3						



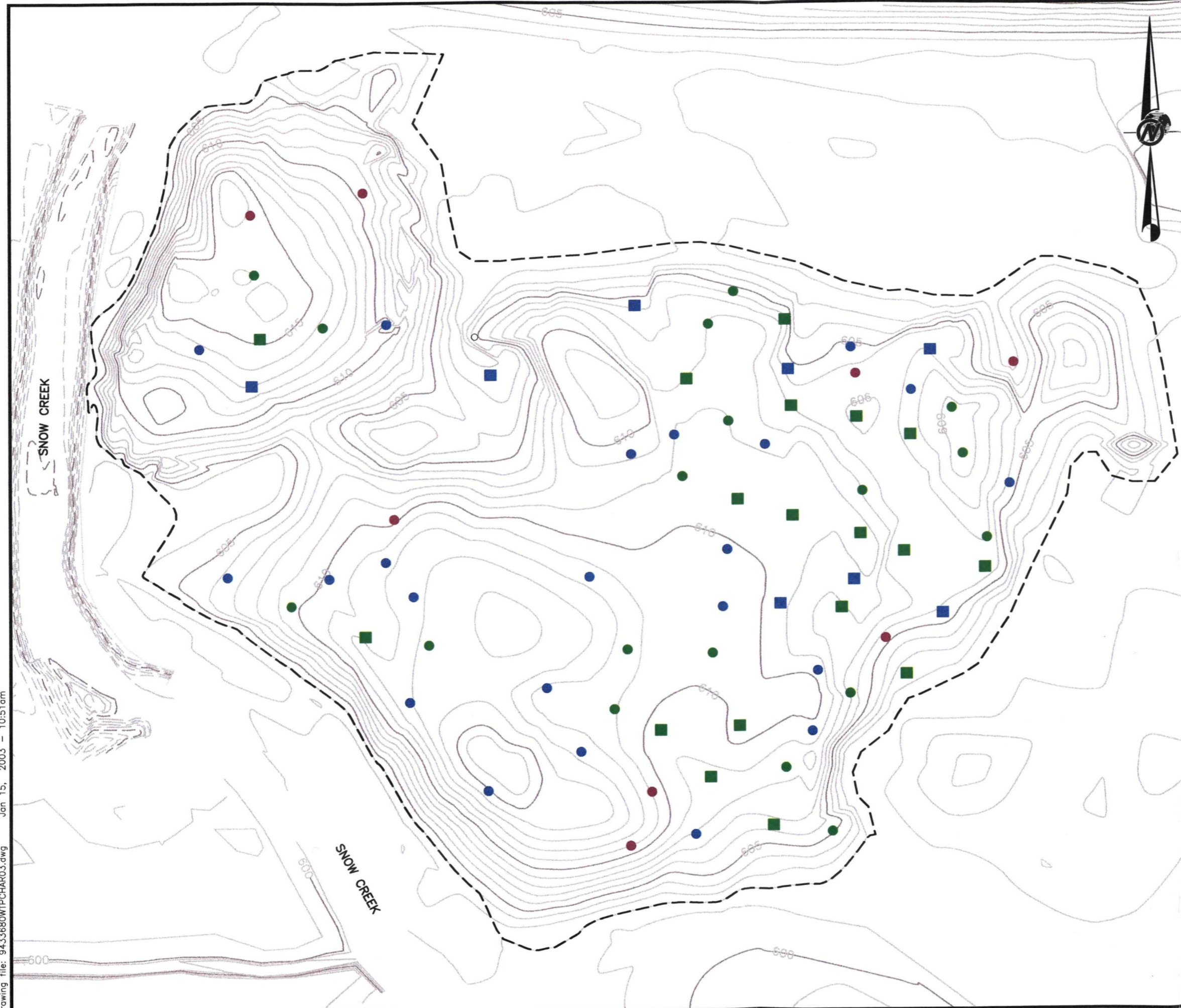

Drawing file: 9433680WTPCHAR03.dwg Jan 15, 2003 - 10:51am

LEGEND

CHEMISTRY SAMPLES

CLASSIFIED ACCORDING TO DETECTION LEVEL:

- BDL (BELOW DETECTION LIMIT) OR < 1 PPM
- 1 TO 50 PPM
- GREATER THAN 50 PPM

IMMUNOASSAY SAMPLES

CLASSIFIED ACCORDING TO DETECTION LEVEL:

- NON-DETECTIONS OR < 1 PPM
- DETECTIONS > 1 PPM
- DETECTIONS > 50 PPM

NOTE: IMMUNOASSAY RESULTS ARE SHOWN ONLY IF CHEMISTRY RESULT DOES NOT EXIST FOR A PARTICULAR LOCATION AT THE SPECIFIED DEPTH.

NOTES

1) SAMPLE LOCATIONS AND RESULTS PROVIDED BY GENESIS PROJECT, INC.

REFERENCES

1) EXISTING TOPOGRAPHY EAST OF SNOW CREEK PROVIDED BY MAXWELL SURVEYING, INC. DATED NOVEMBER, 2002.

2) EXISTING TOPOGRAPHY WITHIN SNOW CREEK AND TO THE WEST OF SNOW CREEK, PROPERTY BOUNDARY, EXISTING UTILITIES AND EASEMENTS PROVIDED BY KREBS ENGINEERING, INC.



REV	DATE	DES	REVISION DESCRIPTION	CADD	CHK	RW
-	-	-	-	-	-	-
PROJECT: SOLUTIA INC. CHOCOLOCCO CREEK WWTP ANNISTON, ALABAMA						
TITLE: PCB CONCENTRATIONS FROM 0 TO 2 FEET BELOW GROUND SURFACE						
PROJECT No. 943-3680		FILE No. 9433690WTPCHAR03				
DESIGN	-	-	SCALE AS SHOWN	REV. -		
CADD	GM	12/02				
CHECK	CMM	01/03				
REVIEW	SJM	01/03				
			4			



Drawing file: 9433680WTPCHAR04.dwg Jan 15, 2003 - 10:26am

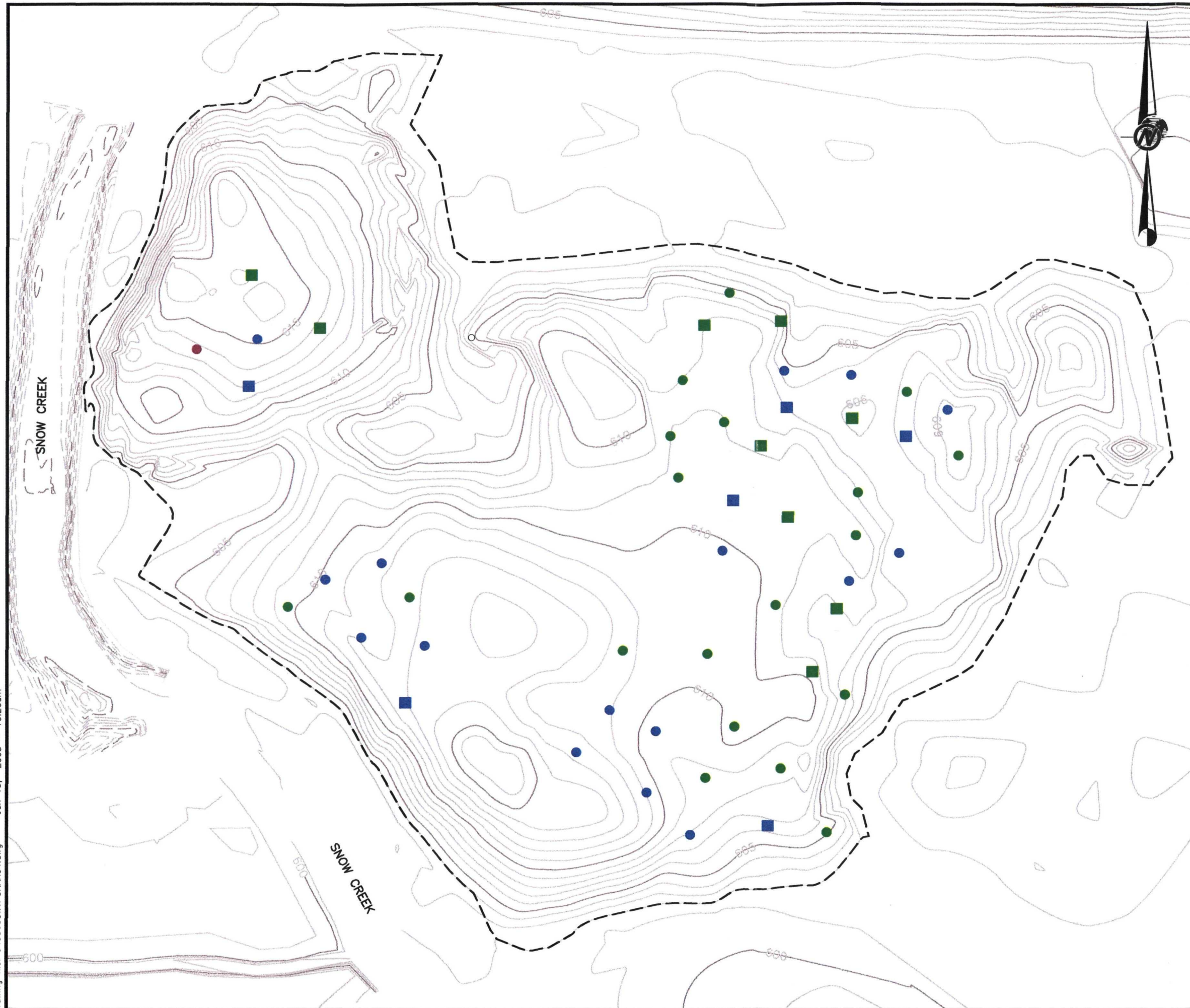

LEGEND

CHEMISTRY SAMPLES

CLASSIFIED ACCORDING TO DETECTION LEVEL:

- BDL (BELOW DETECTION LIMIT) OR < 1 PPM
- 1 TO 50 PPM
- GREATER THAN 50 PPM

IMMUNOASSAY SAMPLES

CLASSIFIED ACCORDING TO DETECTION LEVEL:

- NON-DETECTIONS OR < 1 PPM
- DETECTIONS > 1 PPM
- DETECTIONS > 50 PPM

NOTE: IMMUNOASSAY RESULTS ARE SHOWN ONLY IF CHEMISTRY RESULT DOES NOT EXIST FOR A PARTICULAR LOCATION AT THE SPECIFIED DEPTH.

NOTES

1) SAMPLE LOCATIONS AND RESULTS PROVIDED BY GENESIS PROJECT, INC.

REFERENCES

1) EXISTING TOPOGRAPHY EAST OF SNOW CREEK PROVIDED BY MAXWELL SURVEYING, INC. DATED NOVEMBER, 2002.

2) EXISTING TOPOGRAPHY WITHIN SNOW CREEK AND TO THE WEST OF SNOW CREEK, PROPERTY BOUNDARY, EXISTING UTILITIES AND EASEMENTS PROVIDED BY KREBS ENGINEERING, INC.

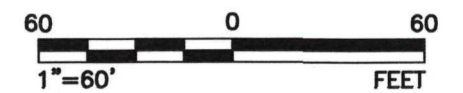

REV	DATE	DES	REVISION DESCRIPTION	CADD	CHK	RW
PROJECT: SOLUTIA INC. CHOCOLOCCO CREEK WWTP ANNISTON, ALABAMA						
TITLE: PCB CONCENTRATIONS FROM 4 TO 6 FEET BELOW GROUND SURFACE						
PROJECT No. 943-3680		FILE No. 9433690WTPCHAR04		SCALE AS SHOWN REV. -		
DESIGN	-	-		5		
CADD	GM	12/02				
CHECK	CMM	01/03				
REVIEW	SJM	01/03				



LEGEND

CHEMISTRY SAMPLES

- CLASSIFIED ACCORDING TO DETECTION LEVEL:
- BDL (BELOW DETECTION LIMIT) OR < 1 PPM
 - 1 TO 50 PPM
 - GREATER THAN 50 PPM

IMMUNOASSAY SAMPLES

- CLASSIFIED ACCORDING TO DETECTION LEVEL:
- NON-DETECTIONS OR < 1 PPM
 - DETECTIONS > 1 PPM
 - DETECTIONS > 50 PPM

NOTE: IMMUNOASSAY RESULTS ARE SHOWN ONLY IF CHEMISTRY RESULT DOES NOT EXIST FOR A PARTICULAR LOCATION AT THE SPECIFIED DEPTH.

NOTES

1) SAMPLE LOCATIONS AND RESULTS PROVIDED BY GENESIS PROJECT, INC.

REFERENCES

- 1) EXISTING TOPOGRAPHY EAST OF SNOW CREEK PROVIDED BY MAXWELL SURVEYING, INC. DATED NOVEMBER, 2002.
- 2) EXISTING TOPOGRAPHY WITHIN SNOW CREEK AND TO THE WEST OF SNOW CREEK, PROPERTY BOUNDARY, EXISTING UTILITIES AND EASEMENTS PROVIDED BY KREBS ENGINEERING, INC.

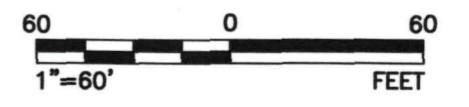

REV	DATE	DES	REVISION DESCRIPTION	CADD	CHK	RW
PROJECT			SOLUTIA INC. CHOCOLOCCK CREEK WWTP ANNISTON, ALABAMA			
TITLE			PCB CONCENTRATIONS FROM 8 TO 10 FEET BELOW GROUND SURFACE			
PROJECT No.		943-3680		FILE No.		9433690WTPCHAR05
DESIGN	-	-	SCALE	AS SHOWN	REV	-
CADD	GM	12/02			6	
CHECK	CMM	01/03				
REVIEW	SJM	01/03				



Drawing file: 9433680WTPCHAR05.dwg Jan 15, 2003 - 10:28am

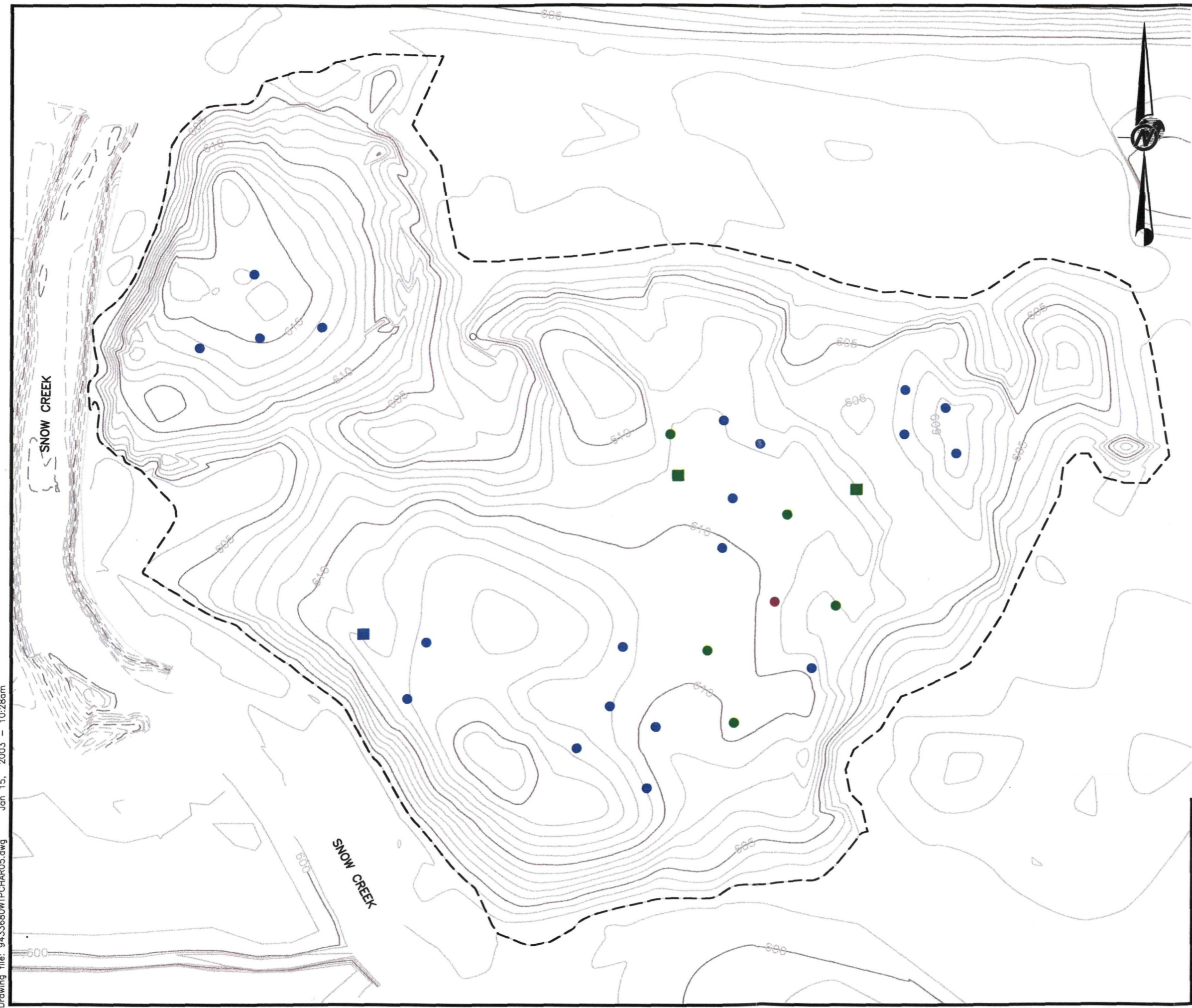

Appendix A - Laboratory Analytical Results

LOG NO: S2-47348A
Received: 11 OCT 02
Reported: 22 OCT 02

Mr. Mike Price
Genesis Project, Inc.
1258 Concord Road
Smyrna, GA 30080

CC: Jerry Hopper

Requisition: V#203708
Contract No.: S7219
Project: Waste Water Stock Pile
Sampled By: Client
Code: 114021023

REPORT OF RESULTS

Page 1

LOG NO	SAMPLE DESCRIPTION , SOLID OR SEMISOLID SAMPLES	DATE/ TIME SAMPLED				
47348A-1	WWSP-3 0-2'	10-02-02/09:32				
47348A-2	WWSP-7 0-1'	10-02-02/10:14				
47348A-3	WWSP-12 0-2'	10-02-02/11:06				
47348A-4	WWSP-13 0-2'	10-02-02/11:08				
47348A-5	WWSP-14 0-1.5'	10-02-02/11:01				
PARAMETER	47348A-1	47348A-2	47348A-3	47348A-4	47348A-5	
PCB's (8082)						
Aroclor-1016, ug/kg dw	<40	<41	<77	<38	<38	
Aroclor-1221, ug/kg dw	<82	<83	<160	<77	<78	
Aroclor-1232, ug/kg dw	<40	<41	1900	<38	<38	
Aroclor-1242, ug/kg dw	<40	120	<77	<38	<38	
Aroclor-1248, ug/kg dw	<40	<41	980	300	63	
Aroclor-1254, ug/kg dw	<40	160	540	450	170	
Aroclor-1260, ug/kg dw	<40	100P	760	450	140P	
Aroclor 1268, ug/kg dw	<40	44	240	140	50	
Surrogate - TCX	32 %	29 %	33 %	33 %	27 %	
Surrogate - DCB	55 %	65 %	174 %	126 %	74 %	
Dilution Factor	1	1	2	1	1	
Prep Date	10.16.02	10.16.02	10.16.02	10.16.02	10.16.02	
Analysis Date	10.18.02	10.18.02	10.21.02	10.18.02	10.18.02	
Batch ID	1016N	1016N	1016N	1016N	1016N	
Percent Solids	82	81	86	87	86	



SEVERN

TRENT

SERVICES

5102 LaRoche Avenue • Savannah, GA 31404 • Tel: 912 354 7858 • Fax: 912 352 0165 • www.stl-inc.com

STL Savannah

LOG NO: S2-47348A
 Received: 11 OCT 02
 Reported: 22 OCT 02

Mr. Mike Price
 Genesis Project, Inc.
 1258 Concord Road
 Smyrna, GA 30080

CC: Jerry Hopper

Requisition: V#203708
 Contract No.: S7219
 Project: Waste Water Stock Pile
 Sampled By: Client
 Code: 114021023

Page 2

REPORT OF RESULTS

LOG NO	SAMPLE DESCRIPTION , SOLID OR SEMISOLID SAMPLES	DATE/ TIME SAMPLED				
47348A-6	WWSP-15 0-1'	10-02-02/17:45				
47348A-7	WWSP-16 0-1'	10-02-02/17:49				
47348A-8	WWSP-18 0-1'	10-02-02/17:50				
47348A-9	WWSP-20 0-1'	10-02-02/18:06				
47348A-10	WWSP-22 0-2'	10-03-02/08:51				
PARAMETER	47348A-6	47348A-7	47348A-8	47348A-9	47348A-10	
PCB's (8082)						
Aroclor-1016, ug/kg dw	<37	<40	<39	<38	<39	
Aroclor-1221, ug/kg dw	<75	<81	<79	<78	<79	
Aroclor-1232, ug/kg dw	<37	<40	<39	<38	<39	
Aroclor-1242, ug/kg dw	<37	<40	<39	<38	<39	
Aroclor-1248, ug/kg dw	100	<40	170	<38	45	
Aroclor-1254, ug/kg dw	210	<40	210	39P	120	
Aroclor-1260, ug/kg dw	260	88	200	47	120	
Aroclor 1268, ug/kg dw	61	<40	47	<38	<39	
Surrogate - TCX	27 %	25 %	38 %	25 %	31 %	
Surrogate - DCB	95 %	60 %	70 %	53 %	75 %	
Dilution Factor	1	1	1	1	1	
Prep Date	10.16.02	10.16.02	10.16.02	10.16.02	10.16.02	
Analysis Date	10.18.02	10.18.02	10.18.02	10.18.02	10.18.02	
Batch ID	1016N	1016N	1016N	1016N	1016N	
Percent Solids	89	83	85	86	85	



LOG NO: S2-47348A
Received: 11 OCT 02
Reported: 22 OCT 02

Mr. Mike Price
Genesis Project, Inc.
1258 Concord Road
Smyrna, GA 30080

CC: Jerry Hopper

Requisition: V#203708
Contract No.: S7219
Project: Waste Water Stock Pile
Sampled By: Client
Code: 114021023

REPORT OF RESULTS

Page 3

LOG NO	SAMPLE DESCRIPTION , SOLID OR SEMISOLID SAMPLES	DATE/ TIME SAMPLED				
47348A-11	WWSP-23 0-1'	10-03-02/08:57				
47348A-12	WWSP-24 0-2'	10-03-02/08:55				
47348A-13	WWSP-25 0-2'	10-03-02/09:00				
47348A-14	WWSP-28 0-1'	10-03-02/09:18				
47348A-15	WWSP-29 0-1'	10-03-02/09:23				
PARAMETER	47348A-11	47348A-12	47348A-13	47348A-14	47348A-15	
PCB's (8082)						
Aroclor-1016, ug/kg dw	<40	<39	<39	<37	<41	
Aroclor-1221, ug/kg dw	<81	<80	<79	<75	<83	
Aroclor-1232, ug/kg dw	<40	<39	<39	<37	<41	
Aroclor-1242, ug/kg dw	<40	<39	<39	<37	<41	
Aroclor-1248, ug/kg dw	69	55P	300	<37	190	
Aroclor-1254, ug/kg dw	210	230	490	<37	220	
Aroclor-1260, ug/kg dw	240	230	480	<37	210	
Aroclor 1268, ug/kg dw	66	62	120	<37	54	
Surrogate - TCX	42 %	33 %	40 %	27 %	35 %	
Surrogate - DCB	90 %	75 %	145 %	52 %	80 %	
Dilution Factor	1	1	1	1	1	
Prep Date	10.16.02	10.16.02	10.16.02	10.16.02	10.16.02	
Analysis Date	10.18.02	10.18.02	10.18.02	10.18.02	10.19.02	
Batch ID	1016N	1016N	1016N	1016N	1016N	
Percent Solids	83	84	85	89	81	

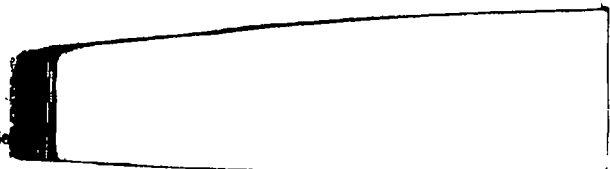



5102 LaRoche Avenue • Savannah, GA 31404 • Tel: 912 354 7858 • Fax: 912 352 0165 • www.st-inc.com

STL Savannah

LOG NO: S2-47348A
Received: 11 OCT 02
Reported: 22 OCT 02

Mr. Mike Price
Genesis Project, Inc.
1258 Concord Road
Smyrna, GA 30080

CC: Jerry Hopper

Requisition: V#203708
Contract No.: S7219
Project: Waste Water Stock File
Sampled By: Client
Code: 114021023

REPORT OF RESULTS

Page 4

LOG NO	SAMPLE DESCRIPTION , QC REPORT FOR SOLID/SEMISOLID	DATE/ TIME SAMPLED		
47348A-16	Method Blank			
47348A-17	Lab Control Standard % Recovery			
47348A-18	LCS Accuracy Control Limit (%R)			
PARAMETER		47348A-16	47348A-17	47348A-18
PCB's (8082)				
Aroclor-1016, ug/kg dw		<33	85 %	34-138 %
Aroclor-1221, ug/kg dw		<67	---	---
Aroclor-1232, ug/kg dw		<33	---	---
Aroclor-1242, ug/kg dw		<33	---	---
Aroclor-1248, ug/kg dw		<33	---	---
Aroclor-1254, ug/kg dw		<33	---	---
Aroclor-1260, ug/kg dw		<33	97 %	39-138 %
Aroclor 1268, ug/kg dw		<33	---	---
Surrogate - TCX		70 %	76 %	30-150 %
Surrogate - DCB		106 %	94 %	30-150 %
Dilution Factor		1	1	---
Prep Date		10.16.02	10.16.02	---
Analysis Date		10.18.02	10.18.02	---
Batch ID		1016N	1016N	---



LOG NO: S2-47348A
Received: 11 OCT 02
Reported: 22 OCT 02

Mr. Mike Price
Genesis Project, Inc.
1258 Concord Road
Smyrna, GA 30080

Requisition: V#203708
Contract No.: S7219
Project: Waste Water Stock Pile
Sampled By: Client
Code: 114021023

CC: Jerry Hopper

Page 5

REPORT OF RESULTS

LOG NO	SAMPLE DESCRIPTION , QC REPORT FOR SOLID/SEMISOLID	DATE/ TIME SAMPLED
47348A-19	LCS 093 - Custom	
47348A-20	True Value - 093 Custom	
PARAMETER	47348A-19	47348A-20
PCB's (8082)		
Aroclor-1248, ug/kg dw	1000	1500
Aroclor-1254, ug/kg dw	2100	3100
Aroclor-1260, ug/kg dw	2200	2000
Aroclor 1268, ug/kg dw	1300	1500
Surrogate - TCX	54 %	---
Surrogate - DCB	135 %	---
Dilution Factor	1	---
Prep Date	10.16.02	---
Analysis Date	10.18.02	---
Batch ID	1016N	---

These test results meet all the requirements of NELAC. All questions regarding this test report should be directed to the STL Project Manager who signed this test report.

SW-846, Test Methods for Evaluating Solid Waste, Third Edition, September 1986, and Updates I, II, IIA, IIB, and III.

P = Identification of target analytes using GC methodology is based on retention time. Although two dissimilar GC columns confirmed the presence of the target analyte in the sample, relative percent difference is >40 %. Thus, viewer discretion should be employed during data review and interpretation of results for this target compound.

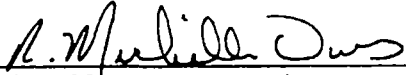
Michelle Owens, Project Manager

Final Page Of Report



**SEVERN
TRENT
SERVICES**

5102 LaRoche Avenue • Savannah, GA 31404 • Tel: 912 354 7858 • Fax: 912 352 0165 • www.st-inc.com

STL Savannah

LOG NO: S2-48313
 Received: 16 NOV 02
 Reported: 25 NOV 02

Mr. Mike Price
 Genesis Project, Inc.
 1258 Concord Road
 Smyrna, GA 30080

Contract No.: S7219
 Project: Anniston Waste Water
 Sampled By: Client
 Code: 160521125

REPORT OF RESULTS

Page 2

LOG NO	SAMPLE DESCRIPTION , SOLID OR SEMISOLID SAMPLES	DATE/ TIME SAMPLED				
48313-6	WWSP-16 (4-6')	11-12-02/09:59				
48313-7	WWSP-60 (7-9')	11-12-02/10:22				
48313-8	WWSP-64 (0-2')	11-12-02/11:18				
48313-9	WWSP-58 (4-6')	11-12-02/11:35				
48313-10	WWSP-50 (0-2')	11-12-02/16:08				
PARAMETER		48313-6	48313-7	48313-8	48313-9	48313-10
PCB's (8082)						
Aroclor-1016, ug/kg dw		<39	<41	<40	<40	<40
Aroclor-1221, ug/kg dw		<79	<84	<81	<81	<81
Aroclor-1232, ug/kg dw		<39	<41	<40	<40	<40
Aroclor-1242, ug/kg dw		670	<41	<40	<40	<40
Aroclor-1248, ug/kg dw		<39	89	94	52	75P
Aroclor-1254, ug/kg dw		500	150	180	130	310
Aroclor-1260, ug/kg dw		490	120	160	110	230
Aroclor 1268, ug/kg dw		120	<41	46	<40	56
Surrogate - TCX		44 %	45 %	50 %	36 %	43 %
Surrogate - DCB		90 %	57 %	80 %	55 %	70 %
Dilution Factor		1	1	1	1	1
Prep Date		11.19.02	11.19.02	11.19.02	11.19.02	11.19.02
Analysis Date		11.21.02	11.21.02	11.21.02	11.21.02	11.21.02
Batch ID		1119N	1119N	1119N	1119N	1119N
Percent Solids		85	80	83	83	83



5102 LaRoche Avenue • Savannah, GA 31404 • Tel: 912 354 7858 • Fax: 912 352 0165 • www.stl-inc.com

STL Savannah

LOG NO: S2-48313
 Received: 16 NOV 02
 Reported: 25 NOV 02

Mr. Mike Price
 Genesis Project, Inc.
 1258 Concord Road
 Smyrna, GA 30080

Contract No.: S7219
 Project: Anniston Waste Water
 Sampled By: Client
 Code: 160521125

REPORT OF RESULTS

Page 3

LOG NO	SAMPLE DESCRIPTION , SOLID OR SEMISOLID SAMPLES	DATE/ TIME SAMPLED				
48313-11	WWSP-50 (4-6')	11-12-02/16:11				
48313-12	WWSP-14 (4-6')	11-12-02/14:27				
48313-13	WWSP-15 (4-6')	11-12-02/15:11				
48313-14	WWSP-57 (0-2')	11-12-02/14:50				
48313-15	WWSP-44 (0-2')	11-13-02/08:31				
PARAMETER	48313-11	48313-12	48313-13	48313-14	48313-15	
PCB's (8082)						
Aroclor-1016, ug/kg dw	<40	<40	<39	<39	<39	
Aroclor-1221, ug/kg dw	<81	<81	<79	<79	<79	
Aroclor-1232, ug/kg dw	<40	<40	<39	<39	<39	
Aroclor-1242, ug/kg dw	<40	<40	<39	<39	<39	
Aroclor-1248, ug/kg dw	260	73	280	120	210	
Aroclor-1254, ug/kg dw	300	160	580	440	530	
Aroclor-1260, ug/kg dw	230	120	500	400	430	
Aroclor 1268, ug/kg dw	60	<40	140	96	89	
Surrogate - TCX	45 %	42 %	38 %	24 %	40 %	
Surrogate - DCB	65 %	60 %	95 %	85 %	80 %	
Dilution Factor	1	1	1	1	1	
Prep Date	11.19.02	11.19.02	11.19.02	11.19.02	11.19.02	
Analysis Date	11.21.02	11.21.02	11.21.02	11.21.02	11.21.02	
Batch ID	1119N	1119N	1119N	1119N	1119N	
Percent Solids	83	83	85	85	85	



5102 LaRoche Avenue • Savannah, GA 31404 • Tel: 912 354 7858 • Fax: 912 352 0165 • www.stl-inc.com

STL Savannah

LOG NO: S2-48313
 Received: 16 NOV 02
 Reported: 25 NOV 02

Mr. Mike Price
 Genesis Project, Inc.
 1258 Concord Road
 Smyrna, GA 30080

Contract No.: S7219
 Project: Anniston Waste Water
 Sampled By: Client
 Code: 160521125
 Page 4

REPORT OF RESULTS

LOG NO	SAMPLE DESCRIPTION , SOLID OR SEMISOLID SAMPLES	DATE/ TIME SAMPLED				
48313-16	WWSP-61 (4-6')	11-12-02/15:30				
48313-17	WWSP-22 (4-6')	11-13-02/08:46				
48313-18	WWSP-49 (8-10')	11-13-02/09:23				
48313-19	WWSP-47 (0-2')	11-13-02/09:40				
48313-20	WWSP-24 (4-6')	11-13-02/11:22				
PARAMETER	48313-16	48313-17	48313-18	48313-19	48313-20	
PCB's (8082)						
Aroclor-1016, ug/kg dw	<40	<39	<42	<40	<42	
Aroclor-1221, ug/kg dw	<82	<80	<86	<81	<86	
Aroclor-1232, ug/kg dw	<40	<39	<42	<40	<42	
Aroclor-1242, ug/kg dw	<40	<39	<42	<40	<42	
Aroclor-1248, ug/kg dw	<40	71	<42	76	160	
Aroclor-1254, ug/kg dw	62	180	<42	360	510	
Aroclor-1260, ug/kg dw	57	130	<42	240	290P	
Aroclor 1268, ug/kg dw	<40	<39	<42	61	130	
Surrogate - TCX	30 %	42 %	35 %	45 %	52 %	
Surrogate - DCB	46 %	60 %	48 %	65 %	176 %	
Dilution Factor	1	1	1	1	1	
Prep Date	11.19.02	11.19.02	11.19.02	11.19.02	11.19.02	
Analysis Date	11.21.02	11.21.02	11.21.02	11.21.02	11.22.02	
Batch ID	1119N	1119N	1119N	1119N	1119N	
Percent Solids	82	84	78	83	78	



5102 LaRoche Avenue • Savannah, GA 31404 • Tel: 912 354 7858 • Fax: 912 352 0165 • www.st-inc.com

STL Savannah

LOG NO: S2-48313
 Received: 16 NOV 02
 Reported: 25 NOV 02

Mr. Mike Price
 Genesis Project, Inc.
 1258 Concord Road
 Smyrna, GA 30080

Contract No.: S7219
 Project: Anniston Waste Water
 Sampled By: Client
 Code: 160521125
 Page 5

REPORT OF RESULTS

LOG NO	SAMPLE DESCRIPTION , SOLID OR SEMISOLID SAMPLES	DATE/ TIME SAMPLED				
48313-21	WWSP-51 (0-2')	11-13-02/14:24				
48313-22	WWSP-51 (4-6')	11-13-02/14:30				
48313-23	WWSP-69 (4-6')	11-13-02/15:33				
48313-24	WWSP-07 (8-10')	11-14-02/09:00				
48313-25	WWSP-71 (4-6')	11-14-02/09:49				
PARAMETER		48313-21	48313-22	48313-23	48313-24	48313-25
PCB's (8082)						
Aroclor-1016, ug/kg dw		<37	<42	<40	<41	<40
Aroclor-1221, ug/kg dw		<75	<85	<81	<83	<81
Aroclor-1232, ug/kg dw		<37	<42	<40	<41	<40
Aroclor-1242, ug/kg dw		<37	<42	<40	<41	<40
Aroclor-1248, ug/kg dw		<37	60P	220	300	<40
Aroclor-1254, ug/kg dw		200	360	580	640	110
Aroclor-1260, ug/kg dw		180	250	440	460	89
Aroclor 1268, ug/kg dw		50	62	120	110	<40
Surrogate - TCX		45 %	40 %	37 %	26 %	30 %
Surrogate - DCB		79 %	71 %	130 %	95 %	60 %
Dilution Factor		1	1	1	1	1
Prep Date		11.19.02	11.19.02	11.19.02	11.19.02	11.19.02
Analysis Date		11.20.02	11.20.02	11.20.02	11.20.02	11.20.02
Batch ID		11190	11190	11190	11190	11190
Percent Solids		89	79	83	81	83

SEVERN

TRENT

SERVICES

5102 LaRoche Avenue • Savannah, GA 31404 • Tel: 912 354 7858 • Fax: 912 352 0165 • www.st-inc.com

STL Savannah

LOG NO: S2-48313

Received: 16 NOV 02

Reported: 25 NOV 02

Mr. Mike Price
 Genesis Project, Inc.
 1258 Concord Road
 Smyrna, GA 30080

Contract No.: S7219

Project: Anniston Waste Water

Sampled By: Client

Code: 160521125

Page 6

REPORT OF RESULTS

LOG NO	SAMPLE DESCRIPTION , SOLID OR SEMISOLID SAMPLES	DATE/ TIME SAMPLED				
48313-26	WWSP-73 (0-2')	11-14-02/10:41				
48313-27	WWSP-73 (4-6')	11-14-02/10:45				
48313-28	WWSP-72 (4-6')	11-14-02/10:05				
48313-29	WWSP-46 (0-2')	11-14-02/08:20				
48313-30	WWSP-47 (4-6') DUP	11-14-02/09:40				
PARAMETER	48313-26	48313-27	48313-28	48313-29	48313-30	
PCB's (8082)						
Aroclor-1016, ug/kg dw	<41	<41	<41	<38	<40	
Aroclor-1221, ug/kg dw	<84	<83	<84	<78	<82	
Aroclor-1232, ug/kg dw	<41	<41	<41	<38	<40	
Aroclor-1242, ug/kg dw	<41	<41	<41	<38	<40	
Aroclor-1248, ug/kg dw	330	410	<41	110P	52P	
Aroclor-1254, ug/kg dw	500	380	130	810	320	
Aroclor-1260, ug/kg dw	370	250	90	690	210	
Aroclor 1268, ug/kg dw	84	60	<41	180	49	
Surrogate - TCX	32 %	36 %	28 %	35 %	44 %	
Surrogate - DCB	67 %	70 %	67 %	137 %	75 %	
Dilution Factor	1	1	1	1	1	
Prep Date	11.19.02	11.19.02	11.19.02	11.19.02	11.19.02	
Analysis Date	11.20.02	11.20.02	11.20.02	11.20.02	11.20.02	
Batch ID	11190	11190	11190	11190	11190	
Percent Solids	80	81	80	86	82	



5102 LaRoche Avenue • Savannah, GA 31404 • Tel: 912 354 7858 • Fax: 912 352 0165 • www.st-inc.com

STL Savannah

LOG NO: S2-48313
Received: 16 NOV 02
Reported: 25 NOV 02

Mr. Mike Price
Genesis Project, Inc.
1258 Concord Road
Smyrna, GA 30080

Contract No.: S7219
Project: Anniston Waste Water
Sampled By: Client
Code: 160521125

REPORT OF RESULTS

Page 7

LOG NO	SAMPLE DESCRIPTION , SOLID OR SEMISOLID SAMPLES	DATE/ TIME SAMPLED
48313-31	WWSP-69 (4-6') DUP	11-13-02/15:33
PARAMETER		48313-31
PCB's (8082)		
Aroclor-1016, ug/kg dw		<40
Aroclor-1221, ug/kg dw		<82
Aroclor-1232, ug/kg dw		<40
Aroclor-1242, ug/kg dw		<40
Aroclor-1248, ug/kg dw		180P
Aroclor-1254, ug/kg dw		850
Aroclor-1260, ug/kg dw		640
Aroclor 1268, ug/kg dw		170
Surrogate - TCX		28 %
Surrogate - DCB		135 %
Dilution Factor		1
Prep Date		11.19.02
Analysis Date		11.20.02
Batch ID		11190
Percent Solids		82



5102 LaRoche Avenue • Savannah, GA 31404 • Tel: 912 354 7858 • Fax: 912 352 0165 • www.stl-inc.com

STL Savannah

LOG NO: S2-48313
 Received: 16 NOV 02
 Reported: 25 NOV 02

Mr. Mike Price
 Genesis Project, Inc.
 1258 Concord Road
 Smyrna, GA 30080

Contract No.: S7219
 Project: Anniston Waste Water
 Sampled By: Client
 Code: 160521125
 Page 8

REPORT OF RESULTS

LOG NO	SAMPLE DESCRIPTION , QC REPORT FOR SOLID/SEMISOLID	DATE/ TIME SAMPLED				
48313-32	Method Blank					
48313-33	Method Blank					
48313-34	Lab Control Standard % Recovery					
48313-35	Lab Control Standard % Recovery					
48313-36	LCS Accuracy Control Limit (%R)					
PARAMETER		48313-32	48313-33	48313-34	48313-35	48313-36
PCB's (8082)						
Aroclor-1016, ug/kg dw	<33	<33	<33	67 %	61 %	34-138 %
Aroclor-1221, ug/kg dw	<67	<67	<67	---	---	---
Aroclor-1232, ug/kg dw	<33	<33	<33	---	---	---
Aroclor-1242, ug/kg dw	<33	<33	<33	---	---	---
Aroclor-1248, ug/kg dw	<33	<33	<33	---	---	---
Aroclor-1254, ug/kg dw	<33	<33	<33	---	---	---
Aroclor-1260, ug/kg dw	<33	<33	<33	67 %	67 %	39-138 %
Aroclor 1268, ug/kg dw	<33	<33	<33	---	---	---
Surrogate - TCX	56 %	59 %	55 %	54 %	54 %	30-150 %
Surrogate - DCB	59 %	65 %	58 %	59 %	59 %	30-150 %
Dilution Factor	1	1	1	1	1	---
Prep Date	11.19.02	11.19.02	11.19.02	11.19.02	11.19.02	---
Analysis Date	11.21.02	11.20.02	11.21.02	11.20.02	11.20.02	---
Batch ID	1119N	11190	1119N	11190	11190	---

LOG NO: S2-48313
Received: 16 NOV 02
Reported: 25 NOV 02

Mr. Mike Price
Genesis Project, Inc.
1258 Concord Road
Smyrna, GA 30080

Contract No.: S7219
Project: Anniston Waste Water
Sampled By: Client
Code: 160521125

REPORT OF RESULTS

Page 9

LOG NO	SAMPLE DESCRIPTION , QC REPORT FOR SOLID/SEMISOLID	DATE/ TIME SAMPLED		
48313-37	LCS - 093 Custom			
48313-38	LCS - 093 Custom			
48313-39	True Value - 093 Custom			
PARAMETER		48313-37	48313-38	48313-39
PCB's (8082)				
Aroclor-1248, ug/kg dw		790	610	1500
Aroclor-1254, ug/kg dw		2100	2300	3100
Aroclor-1260, ug/kg dw		1700	1800	2000
Aroclor 1268, ug/kg dw		970	1200	1500
Surrogate - TCX		59 %	42 %	---
Surrogate - DCB		82 %	106 %	---
Dilution Factor		1	1	---
Prep Date		11.19.02	11.19.02	---
Analysis Date		11.21.02	11.20.02	---
Batch ID		1119N	11190	---

These test results meet all the requirements of NELAC. All questions regarding this test report should be directed to the STL Project Manager who signed this test report.

SW-846, Test Methods for Evaluating Solid Waste, Third Edition, September 1986, and Updates I, II, IIA, IIB, and III.

P = Identification of target analytes using GC methodology is based on retention time. Although two dissimilar GC columns confirmed the presence of the target analyte in the sample, relative percent difference is >40 %. Thus, viewer discretion should be employed during data review and interpretation of results for this target compound.

Michelle Owens, Project Manager

Final Page Of Report

Appendix B - Construction Drawings

SOLUTIA INCORPORATED CONSTRUCTION DRAWINGS FOR CORRECTIVE MEASURES IMPLEMENTATION EXCAVATED SOIL STOCKPILE AT CHOCCOLOCCO CREEK WWTP ANNISTON, ALABAMA



VICINITY MAP

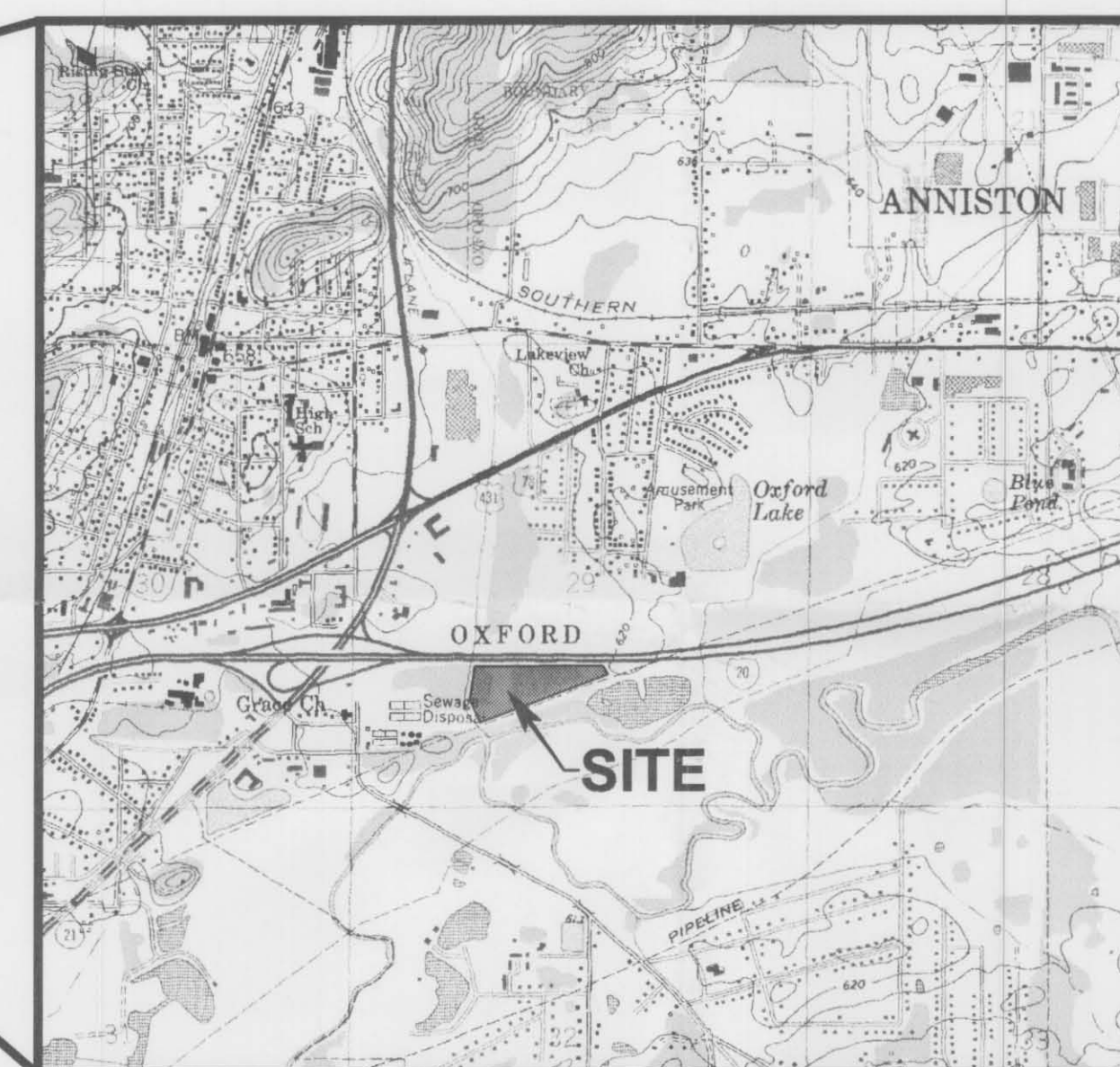

REF: USGS 7.5 MINUTE OXFORD QUADRANGLE

SITE LOCATION MAP

2000 0 2000
1"=2000' FEET

INDEX TO DRAWINGS

1. COVER SHEET
2. EXISTING CONDITIONS / GENERAL SITE PLAN
3. TOP OF PCB-CONTAINING EARTH FILL
4. TOP OF FINAL COVER
5. EROSION & SEDIMENT CONTROL PLAN
6. COVER SYSTEM SECTIONS & DETAILS
7. EROSION & SEDIMENT CONTROL DETAILS

PLANS PREPARED FOR:
SOLUTIA INCORPORATED
702 CLYDESDALE AVENUE
ANNISTON, ALABAMA 36201



PLANS PREPARED BY:
GOLDER ASSOCIATES, INC.
3730 CHAMBLEE TUCKER ROAD
ATLANTA, GEORGIA 30341



01/16/03

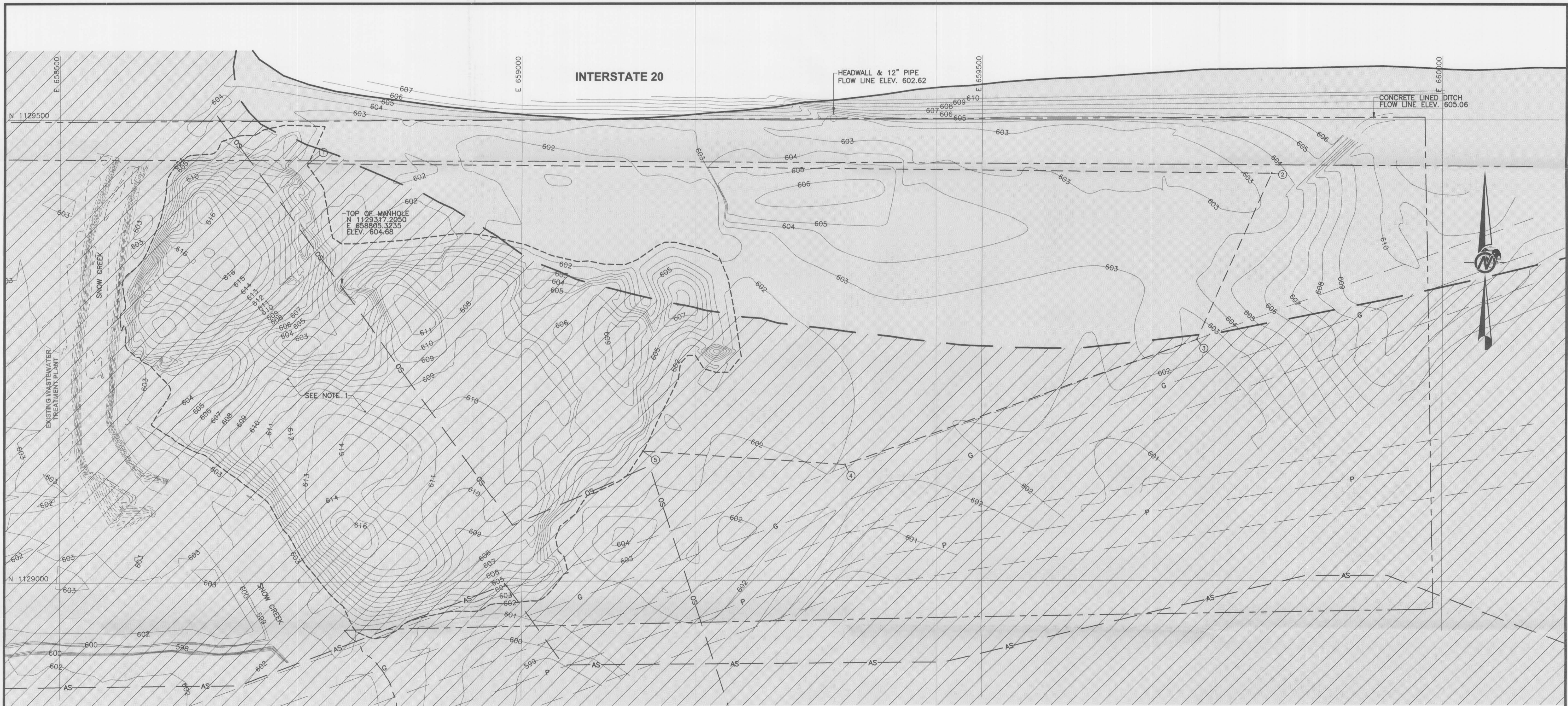

**LIMITS OF CLEARING
COORDINATE DATA**

POINT	NORTHING	EASTING	DESCRIPTION
①	N 1129452.0	E 658768.6	CLEARING LIMITS
②	N 1129441.2	E 659815.2	CLEARING LIMITS
③	N 1129261.0	E 659734.1	CLEARING LIMITS
④	N 1129125.3	E 659351.2	CLEARING LIMITS
⑤	N 1129140.3	E 659132.0	CLEARING LIMITS

NOTES:

1. AREA SHALL BE RESTORED TO THE ORIGINAL ELEVATIONS. THE ORIGINAL SURFACE WILL BE IDENTIFIED WHEN A CONTINUOUS LAYER OF ORGANIC MATTER IS ENCOUNTERED. THIS LAYER WILL DENOTE THE PREVIOUS PRESENCE OF VEGETATION. IT IS EXPECTED THAT THIS LAYER WILL BE FOUND BETWEEN ELEVATIONS 601 AND 603 FT. MSL. CONTRACTOR SHALL NOT EXCAVATE BELOW THE ORIGINAL GROUND SURFACE.
2. CONTRACTOR SHALL CUT AND FELL TREES IN AREA SHOWN AND ON STOCKPILE IN ACCORDANCE WITH TECHNICAL SPECIFICATIONS.
3. THE LOCATION OF THE OXFORD SANITARY SEWER LINE TO BE CONFIRMED PRIOR TO COMMENCING CONSTRUCTION ACTIVITIES.
4. OWNER SHALL PROVIDE TWO BENCHMARKS FOR SURVEY CONTROL DURING CONSTRUCTION.
5. THE AREA OF THE EXISTING PCB-CONTAINING STOCKPILE IS APPROXIMATELY 4.8 ACRES.
6. THE LIMITS OF CLEARING OUTSIDE THE EXISTING PCB-CONTAINING STOCKPILE IS APPROXIMATELY 4.3 ACRES.

REFERENCES:

1. EXISTING TOPOGRAPHY EAST OF SNOW CREEK PROVIDED BY MAXWELL SURVEYING, INC., DATED NOVEMBER, 2002.
2. EXISTING TOPOGRAPHY WITHIN SNOW CREEK AND WEST OF SNOW CREEK, PROPERTY BOUNDARY, EXISTING UTILITIES AND EASEMENTS PROVIDED BY KREBS ENGINEERING, INC.

ALABAMA REGISTERED PROFESSIONAL ENGINEER
WILLIAM R. SULLIVAN
Jan 16, 2003
01/16/03

LEGEND

- PROPERTY BOUNDARY AND/OR RIGHT-OF-WAY
- 605 --- EXISTING CONTOURS
- G --- EXISTING GAS MAIN
- P --- EXISTING POWERLINE
- OS-AS --- EXISTING SANITARY SEWER (SEE NOTE 3)
(OS-CITY OF OXFORD/
AS-CITY OF ANNISTON)
- APPROXIMATE LIMITS OF EXISTING PCB-CONTAINING SOIL STOCKPILE (SEE NOTE 1)
- LIMITS OF CLEARING (SEE NOTE 2)
- [Hatched Box] SPECIAL FLOOD HAZARD AREA INUNDED BY 100-YEAR FLOOD - ZONE AE
- [Diagonal Lines Box] FLOODWAY IN ZONE AE



REV	DATE	DES	REVISION DESCRIPTION	CADD	CHK	RW
PROJECT						
SOLUTIA INCORPORATED CHOCOLOCCO CREEK WWTP ANNISTON, ALABAMA						
TITLE						
EXISTING CONDITIONS / GENERAL SITE PLAN						
PROJECT No. 943-3680			FILE No. 02-EX-CONDITIONS			
DESIGN	CMM	12/02	SCALE	AS SHOWN	REV.	-
CADD	RMS	12/02				
CHECK	SJM	01/03				
REVIEW	WRS	01/03				
Golder Associates Atlanta, Georgia						2

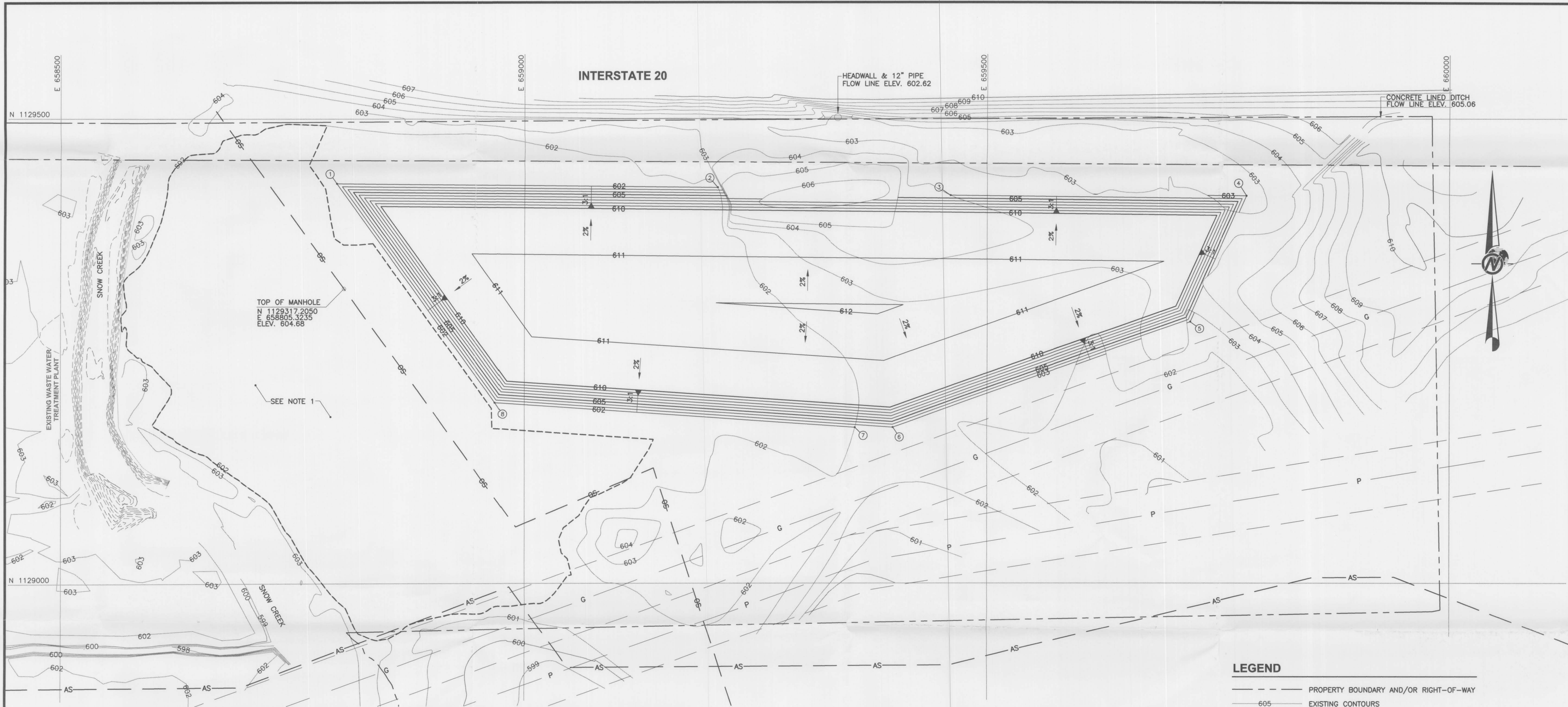

TOP OF MANHOLE
 N 1129317.2050
 E 658805.3235
 ELEV. 604.68

SEE NOTE 1

EARTHFILL EMBANKMENT COORDINATE DATA

POINT	NORTHING	EASTING	ELEVATION	DESCRIPTION
①	N 1129430.4	E 658797.5	602	TOE OF SLOPE
②	N 1129426.2	E 659208.5	602	TOE OF SLOPE
③	N 1129417.6	E 659460.2	604	TOE OF SLOPE
④	N 1129417.3	E 659781.0	603	TOE OF SLOPE
⑤	N 1129281.8	E 659720.1	603	TOE OF SLOPE
⑥	N 1129167.8	E 659398.1	603	TOE OF SLOPE
⑦	N 1129167.6	E 659357.1	602	TOE OF SLOPE
⑧	N 1129194.2	E 658968.1	602	TOE OF SLOPE

NOTES:

- AREA SHALL BE RESTORED TO THE ORIGINAL ELEVATIONS. THE ORIGINAL SURFACE WILL BE IDENTIFIED WHEN A CONTINUOUS LAYER OF ORGANIC MATTER IS ENCOUNTERED. THIS LAYER WILL DENOTE THE PREVIOUS PRESENCE OF VEGETATION. IT IS EXPECTED THAT THIS LAYER WILL BE FOUND BETWEEN ELEVATIONS 601 AND 603 FT. MSL. CONTRACTOR SHALL NOT EXCAVATE BELOW THE ORIGINAL GROUND SURFACE.
- CONTRACTOR SHALL PLACE AND COMPACT PCB-CONTAINING EARTH FILL IN ACCORDANCE WITH THE TECHNICAL SPECIFICATIONS. THE PROPOSED GRADES SHOWN ON THIS DRAWING MAY VARY DEPENDING UPON THE AMOUNT OF EARTH FILL PRESENT IN THE EXISTING STOCKPILE. THE CONTRACTOR SHALL BEGIN PLACING EARTH FILL AT THE HORIZONTAL EXTENTS SHOWN ON THIS DRAWING AND VARY THE HEIGHT OF THE TOP OF THE COVER TO INCLUDE ALL SOIL MATERIAL FROM THE STOCKPILE (INCLUDING THE STOCKPILED SOIL WEST OF SNOW CREEK THAT WAS PLACED DURING PREVIOUS INTERIM MEASURES). THE CONTRACTOR SHALL MAINTAIN A 2% SLOPE ON THE TOP OF THE FINAL COVER.
- THE LOCATION OF THE OXFORD SANITARY SEWER LINE TO BE CONFIRMED PRIOR TO COMMENCING CONSTRUCTION ACTIVITIES.

REFERENCES:

- EXISTING TOPOGRAPHY EAST OF SNOW CREEK PROVIDED BY MAXWELL SURVEYING, INC., DATED NOVEMBER, 2002.
- EXISTING TOPOGRAPHY WITHIN SNOW CREEK AND WEST OF SNOW CREEK, PROPERTY BOUNDARY, EXISTING UTILITIES AND EASEMENTS PROVIDED BY KREBS ENGINEERING, INC.

LEGEND

- PROPERTY BOUNDARY AND/OR RIGHT-OF-WAY
- 605 EXISTING CONTOURS
- G EXISTING GAS MAIN
- P EXISTING POWERLINE
- OS-AS EXISTING SANITARY SEWER (SEE NOTE 3)
(OS-CITY OF OXFORD/
AS-CITY OF ANNISTON)
- APPROXIMATE LIMITS OF EXISTING PCB-CONTAINING SOIL STOCKPILE (SEE NOTE 1)
- 605 PROPOSED EARTH FILL CONTOURS (5FT. INTERVALS)
- 604 PROPOSED EARTH FILL CONTOURS (1FT. INTERVALS)



Jan 16, 2003
 01/16/03

REV	DATE	DES	REVISION DESCRIPTION	CADD	CHK	R/W

PROJECT: SOLUTIA INCORPORATED
 CHOCCOLOCCO CREEK WWTP
 ANNISTON, ALABAMA

TITLE: **TOP OF PCB-CONTAINING EARTH FILL**

PROJECT No.	943-3680	FILE No.	03-FILL-PLAN
DESIGN	CMM 12/02	SCALE	AS SHOWN REV. -
CADD	RMS 12/02		
CHECK	SJM 01/03		
REVIEW	WRS 01/03		



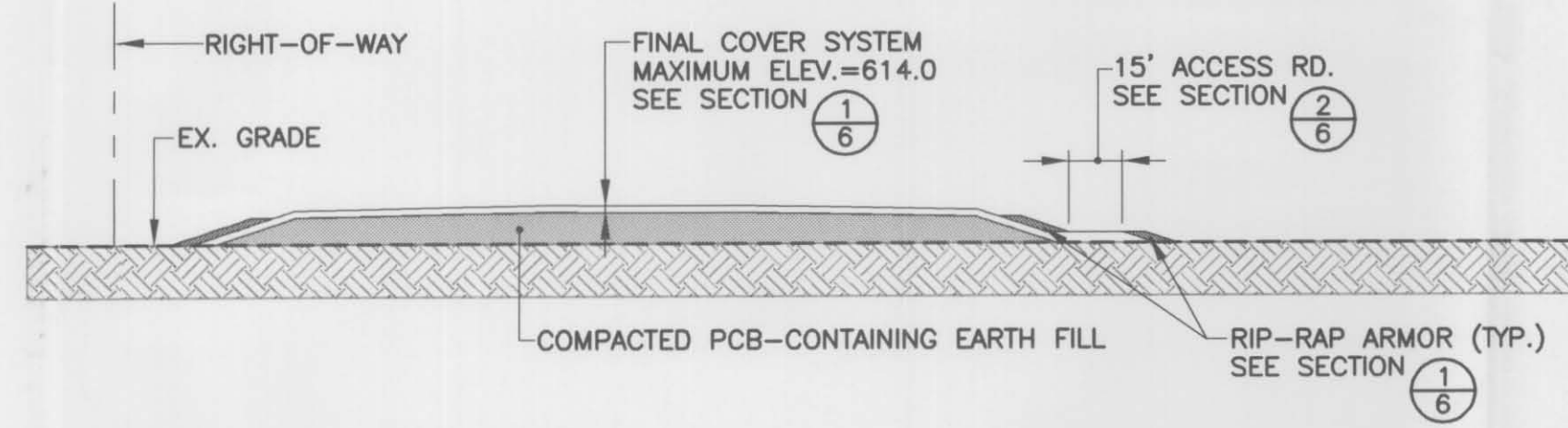
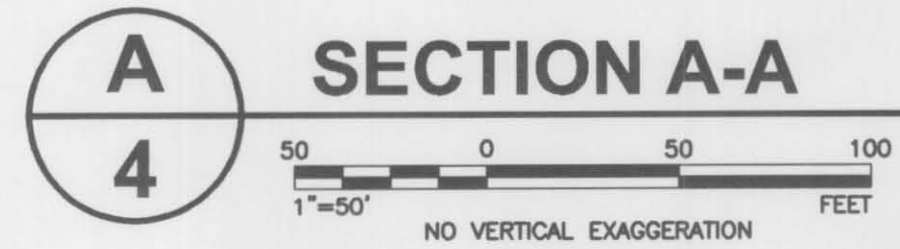
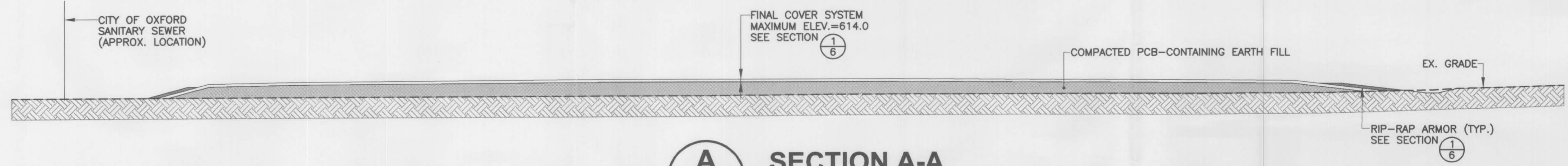
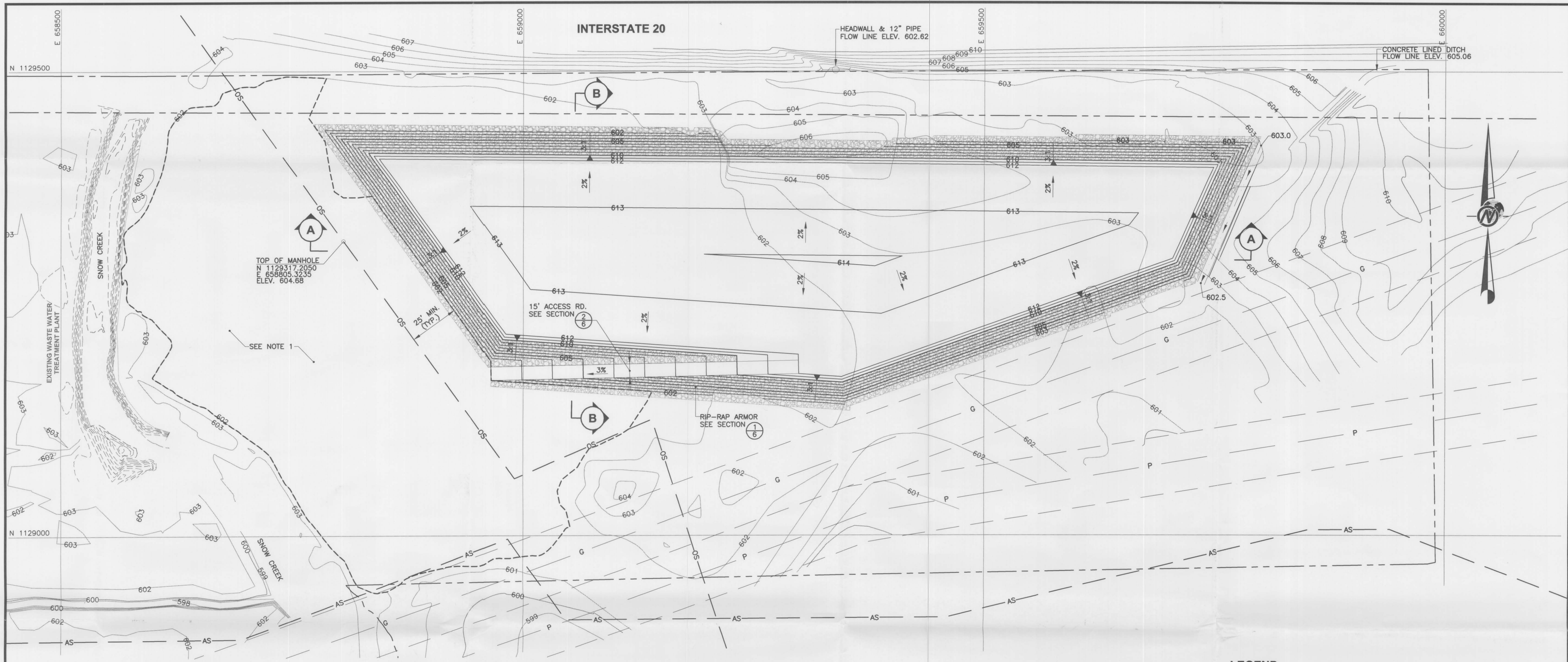

LEGEND

- PROPERTY BOUNDARY AND/OR RIGHT-OF-WAY
- 605 EXISTING CONTOURS
- G EXISTING GAS MAIN
- P EXISTING POWERLINE
- OS AS EXISTING SANITARY SEWER (SEE NOTE 3)
(OS-CITY OF OXFORD/
AS-CITY OF ANNISTON)
- APPROXIMATE LIMITS OF EXISTING PCB-CONTAINING SOIL STOCKPILE (SEE NOTE 1)
- 605 PROPOSED FINAL COVER CONTOURS (5FT. INTERVALS)
- 604 PROPOSED FINAL COVER CONTOURS (1FT. INTERVALS)



- NOTES:**
- AREA SHALL BE RESTORED TO THE ORIGINAL ELEVATIONS. THE ORIGINAL SURFACE WILL BE IDENTIFIED WHEN A CONTINUOUS LAYER OF ORGANIC MATTER IS ENCOUNTERED. THIS LAYER WILL DENOTE THE PREVIOUS PRESENCE OF VEGETATION. IT IS EXPECTED THAT THIS LAYER WILL BE FOUND BETWEEN ELEVATIONS 601 AND 603 FT. MSL. CONTRACTOR SHALL NOT EXCAVATE BELOW THE ORIGINAL GROUND SURFACE.
 - CONTRACTOR SHALL PLACE AND COMPACT PCB-CONTAINING EARTH FILL IN ACCORDANCE WITH THE TECHNICAL SPECIFICATIONS. THE PROPOSED GRADES SHOWN ON THIS DRAWING MAY VARY DEPENDING UPON THE AMOUNT OF EARTH FILL PRESENT IN THE EXISTING STOCKPILE. THE CONTRACTOR SHALL BEGIN PLACING EARTH FILL AT THE HORIZONTAL EXTENTS SHOWN ON THIS DRAWING AND VARY THE HEIGHT OF THE TOP OF THE COVER TO INCLUDE ALL SOIL MATERIAL FROM THE STOCKPILE (INCLUDING THE STOCKPILED SOIL WEST OF SNOW CREEK THAT WAS PLACED DURING PREVIOUS INTERIM MEASURES). THE CONTRACTOR SHALL MAINTAIN A 2% SLOPE ON THE TOP OF THE FINAL COVER.
 - THE LOCATION OF THE OXFORD SANITARY SEWER LINE TO BE CONFIRMED PRIOR TO COMMENCING CONSTRUCTION ACTIVITIES.

- REFERENCES:**
- EXISTING TOPOGRAPHY EAST OF SNOW CREEK PROVIDED BY MAXWELL SURVEYING, INC., DATED NOVEMBER, 2002.
 - EXISTING TOPOGRAPHY WITHIN SNOW CREEK AND WEST OF SNOW CREEK, PROPERTY BOUNDARY, EXISTING UTILITIES AND EASEMENTS PROVIDED BY KREBS ENGINEERING, INC.

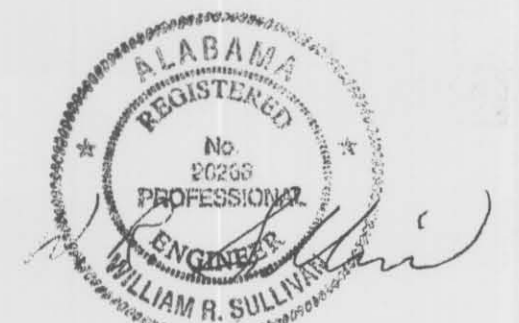

Jan 16, 2003
01/16/03

REV	DATE	DES	REVISION DESCRIPTION	CADD	CHK	RVW
PROJECT: SOLUTIA INCORPORATED CHOCOLOCCO CREEK WWTP ANNISTON, ALABAMA						
TITLE: TOP OF FINAL COVER						
PROJECT No.	943-3680	FILE No.	04-COVER-PLAN			
DESIGN	CMM	12/02	SCALE	AS SHOWN	REV.	
CADD	RMS	12/02				
CHECK	SJM	01/03				
REVIEW	WRS	01/03				
Golder Associates Atlanta, Georgia						4

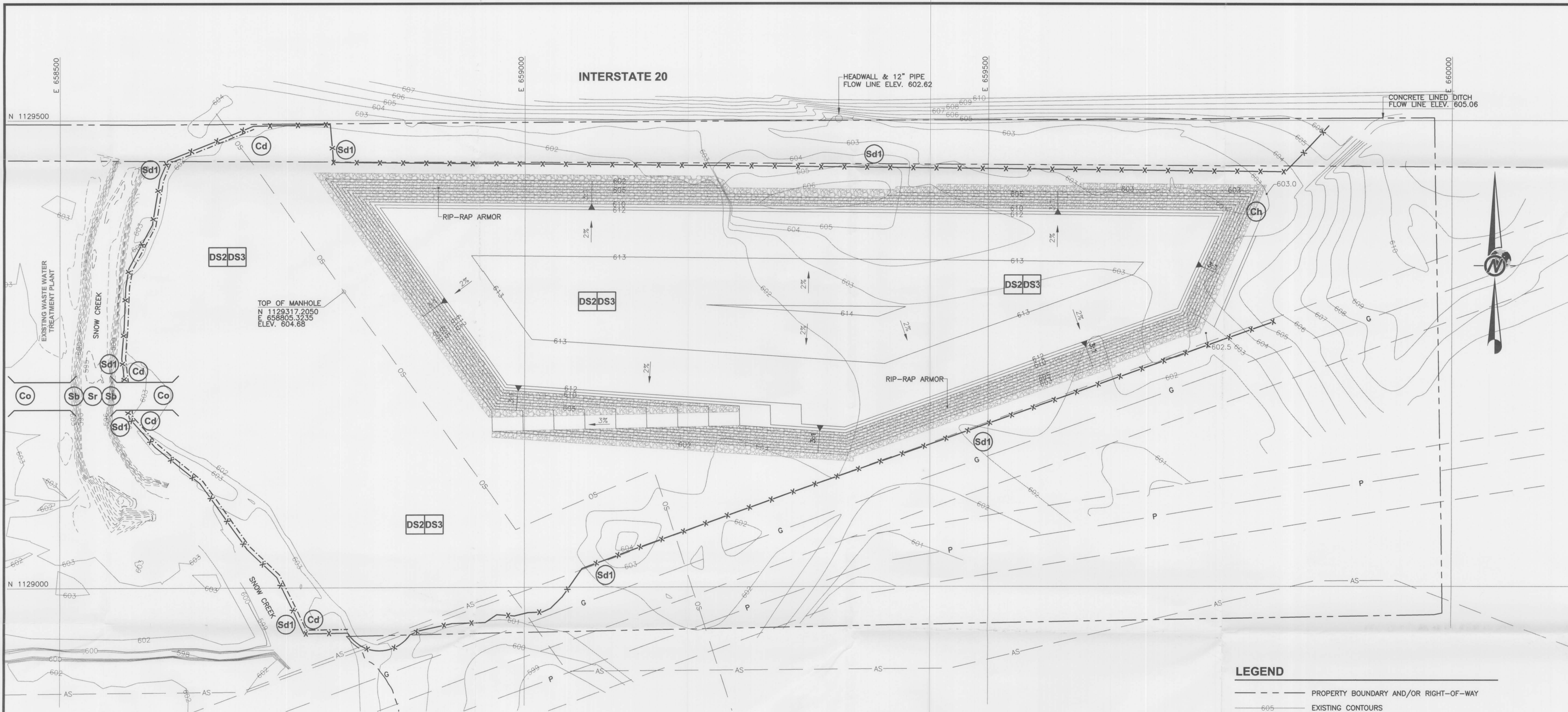

INTERSTATE 20

HEADWALL & 12" PIPE
FLOW LINE ELEV. 602.62

CONCRETE LINED DITCH
FLOW LINE ELEV. 605.06

TOP OF MANHOLE
N 1129317.2050
E 658805.3235
ELEV. 604.68

LEGEND

- PROPERTY BOUNDARY AND/OR RIGHT-OF-WAY
- 605 EXISTING CONTOURS
- G EXISTING GAS MAIN
- P EXISTING POWERLINE
- OS AS EXISTING SANITARY SEWER (SEE NOTE 3)
(OS-CITY OF OXFORD/
AS-CITY OF ANNISTON)
- 605 PROPOSED EARTH FILL CONTOURS (5FT. INTERVALS)
- 604 PROPOSED EARTH FILL CONTOURS (1FT. INTERVALS)



EROSION & SEDIMENTATION CONTROL LEGEND

KEY	SYMBOL	DESCRIPTION
Co		CONSTRUCTION ENTRANCE
Cd		HAYBALE CHECK DAM
Ch		CHANNEL STABILIZATION (RIP-RAP)
DS2		DISTURBED AREA STABILIZATION (TEMPORARY SEEDING/EXCEPT WHERE SLOPES ARE RIP-RAPPED)
DS3		DISTURBED AREA STABILIZATION (PERMANENT SEEDING/EXCEPT WHERE SLOPES ARE RIP-RAPPED)
Sd1		SEDIMENT BARRIER (TYPE C SILT FENCE W/WOOD POST)
Sb		STREAMBANK STABILIZATION
Sr		TEMPORARY STREAM CROSSING (BRIDGE REQUIRED)

NOTE: FOR EROSION & SEDIMENTATION CONTROL DETAILS SEE SHEET 7.

NOTES:

- CONTRACTOR IS RESPONSIBLE FOR ALL APPLICABLE FEDERAL, STATE, AND LOCAL LAWS REGARDING EROSION AND SEDIMENTATION CONTROL.
- AN NPDES PERMIT FROM THE ALABAMA DEPARTMENT OF ENVIRONMENTAL MANAGEMENT IS REQUIRED PRIOR TO COMMENCING CONSTRUCTION ACTIVITIES.
- THE LOCATION OF THE OXFORD SANITARY SEWER LINE TO BE CONFIRMED PRIOR TO COMMENCING CONSTRUCTION ACTIVITIES.

REFERENCES:

- EXISTING TOPOGRAPHY EAST OF SNOW CREEK PROVIDED BY MAXWELL SURVEYING, INC., DATED NOVEMBER, 2002.
- EXISTING TOPOGRAPHY WITHIN SNOW CREEK AND WEST OF SNOW CREEK, PROPERTY BOUNDARY, EXISTING UTILITIES AND EASEMENTS PROVIDED BY KREBS ENGINEERING, INC.

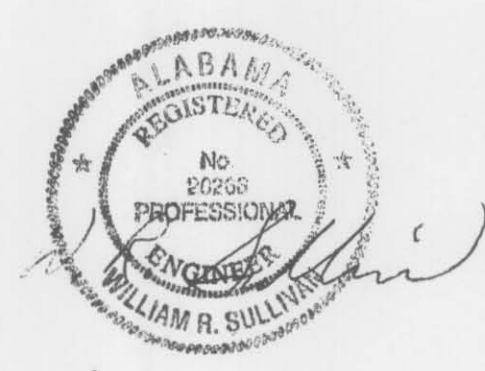

Jan 16, 2003

01/16/03

REV	DATE	DES	REVISION DESCRIPTION	CADD	CHK	RVW
PROJECT						
SOLUTIA INCORPORATED CHOCOLOCCO CREEK WWTP ANNISTON, ALABAMA						
TITLE						
EROSION & SEDIMENT CONTROL PLAN						
PROJECT No.		943-3680		FILE No.		05-EROS-SED-PLAN
DESIGN	CMM	12/02	SCALE	AS SHOWN	REV.	-
CADD	RMS	12/02				
CHECK	SJM	01/03				
REVIEW	WRS	01/03				
						5
Golder Associates Atlanta, Georgia						

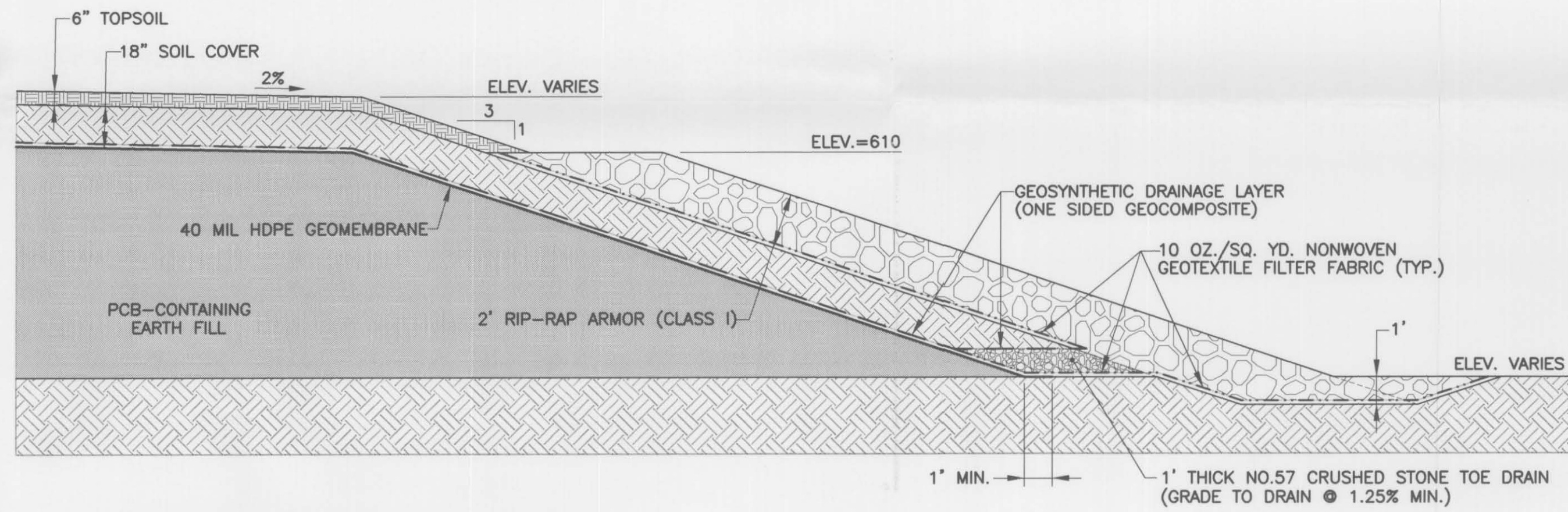

1
6 TYPICAL CREST COVER SECTION

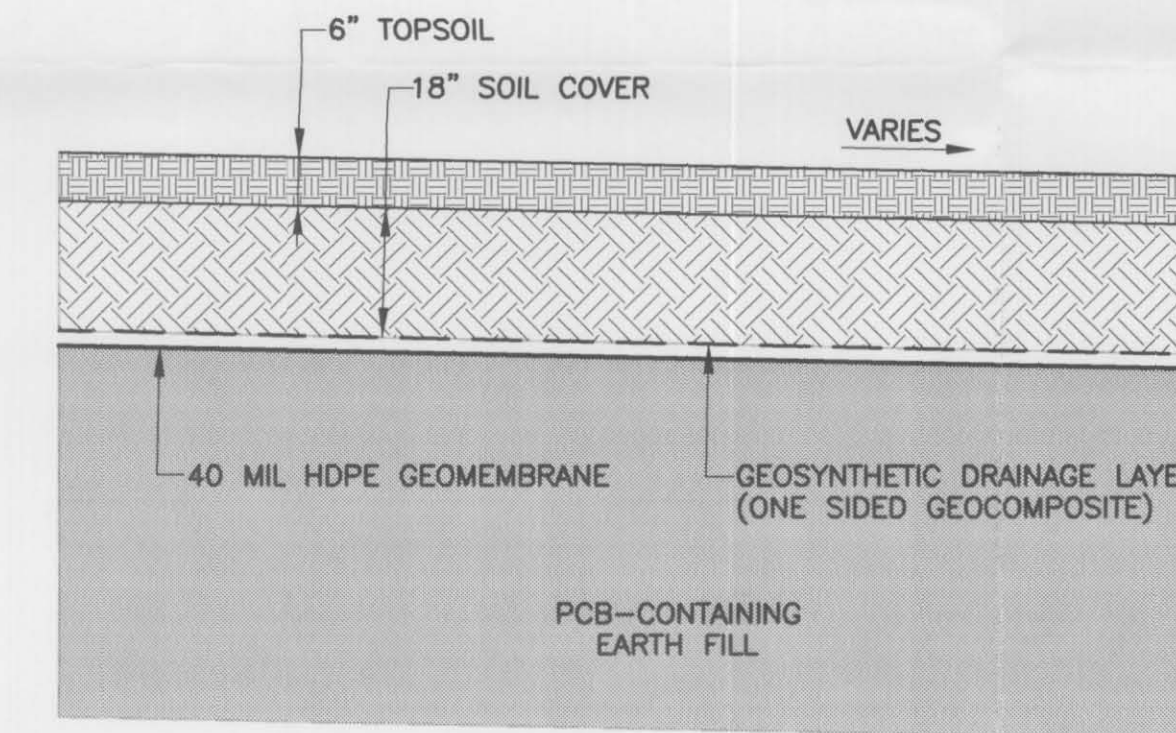

3
6 TYPICAL COVER SYSTEM DETAIL

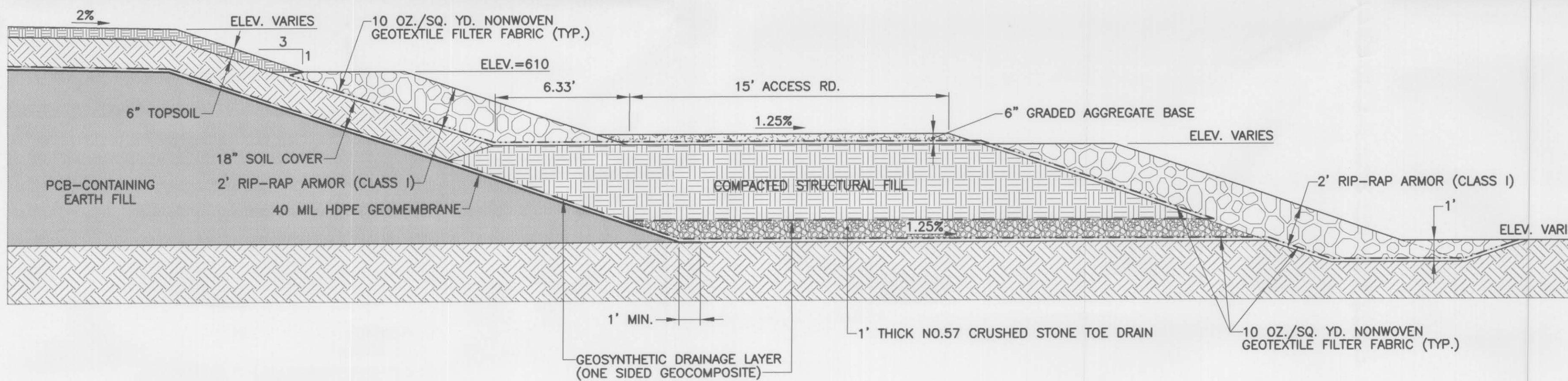

2
6 TYPICAL ACCESS ROAD SECTION

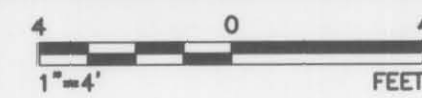

NOTE:

CONTRACTOR SHALL KEEP TOE DRAIN COVERED WITH THE GEOSYNTHETIC DRAINAGE LAYER DURING PLACEMENT OF SOIL COVER MATERIAL. THE DRAINAGE LAYER SHALL BE CUT AND REMOVED FROM THE FACE OF THE TOE DRAIN PRIOR TO PLACING RIP-RAP ARMOR OR GEOTEXTILE.

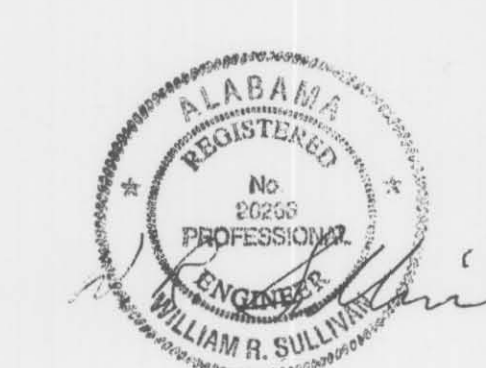

Jan 16, 2003
01/16/03

REV	DATE	DES	REVISION DESCRIPTION	CADD	CHK	RW
-	-	-	-	-	-	-
PROJECT: SOLUTIA INCORPORATED CHOCOLOCCO CREEK WWTP ANNISTON, ALABAMA						
TITLE: COVER SYSTEM SECTIONS & DETAILS						
PROJECT No.		943-3680		FILE No.		06-COVER-DETAILS
DESIGN	CMM	12/02	SCALE	AS SHOWN	REV.	-
CADD	RMS	12/02				
CHECK	SJM	01/03				
REVIEW	WRS	01/03				
6						



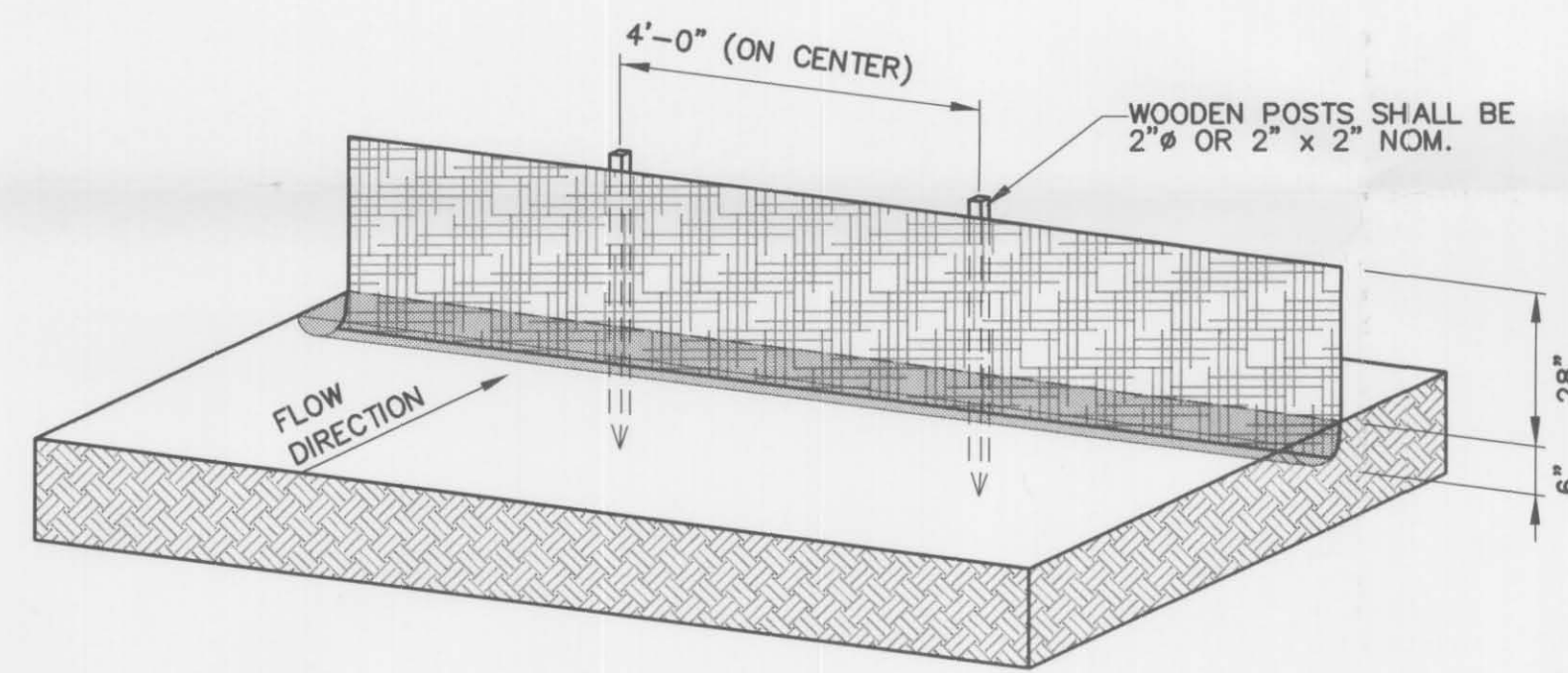

NOTES:

1. SILT CONTROL SHALL BE IN EFFECT PRIOR TO ANY GRADING OR CONSTRUCTION.
2. USE TYPE 'C' WIRE-REINFORCED SILT FENCE.
3. SPLICED JOINTS SHALL OVERLAP 18", WITH MATCHING POST.
4. DRIVE 4" (48") MIN. POSTS 12"-18" INTO SOIL.
5. DIG DITCH 12" WIDE, 6" DEEP. LAY FABRIC 6"-8" DEEP, THEN BACKFILL.

Sd₁ TYPE C SILT FENCE DETAIL
NTS

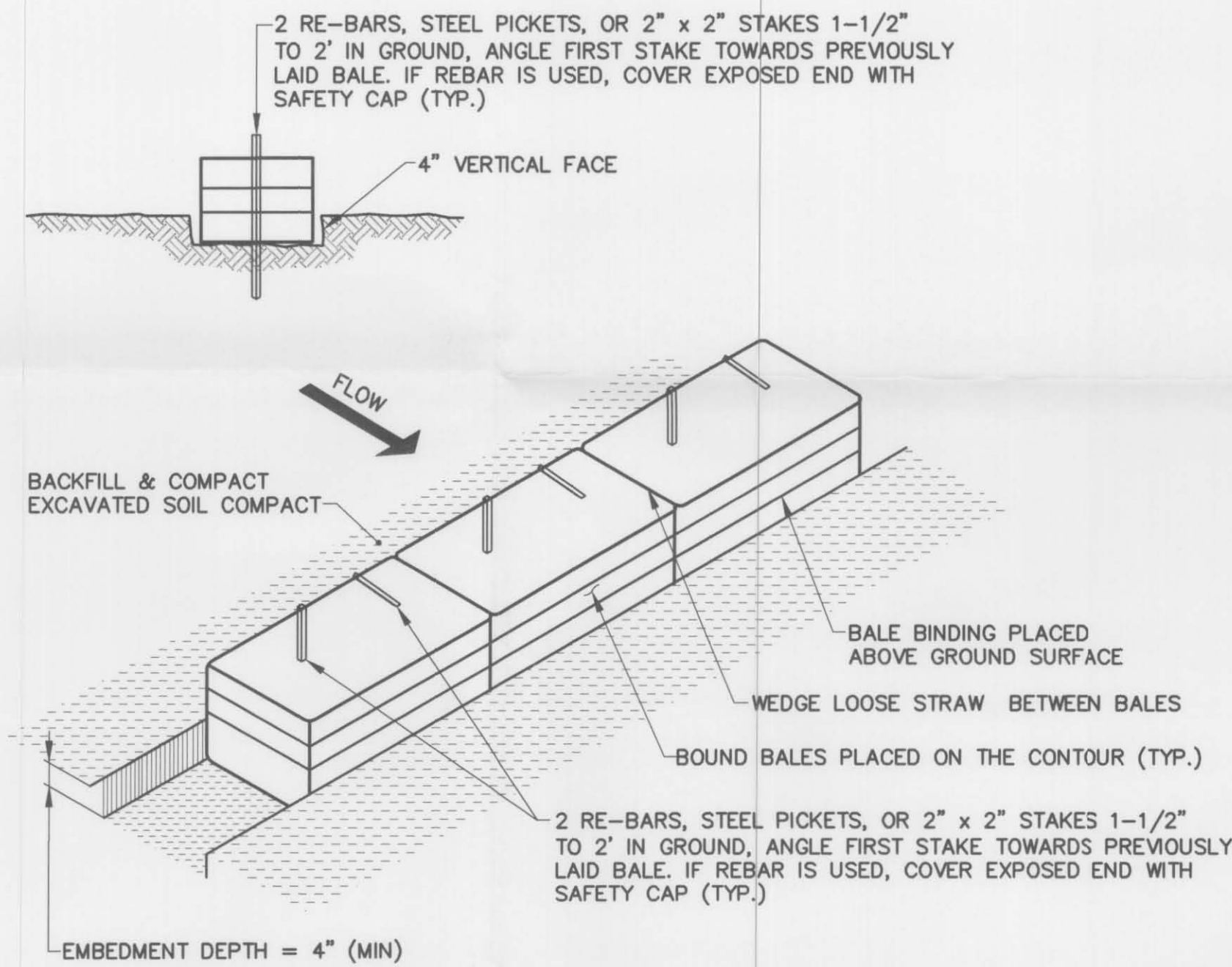

NOTE: PLACE HAY BALES STAKED AT STREAM CROSSING APPROACHES AS WELL AS PARALLEL TO THE LENGTH OF DISTURBED AREA ALONG THE BANKS OF SNOW CREEK TO CATCH SEDIMENT BEFORE IT ENTERS THE STREAM. LOCATE HAY BALES IN FRONT OF THE LINE OF SILT FENCES INSTALLED TO INTERCEPT AS MUCH SEDIMENT AS POSSIBLE. HAY BALES THAT BECOME FULL OF SEDIMENT SHOULD BE REMOVED AND PLACED AWAY FROM THE BANKS OF THE STREAM AND REPLACED WITH FRESH ONES.

Cd HAYBALE CHECK DAM
NTS

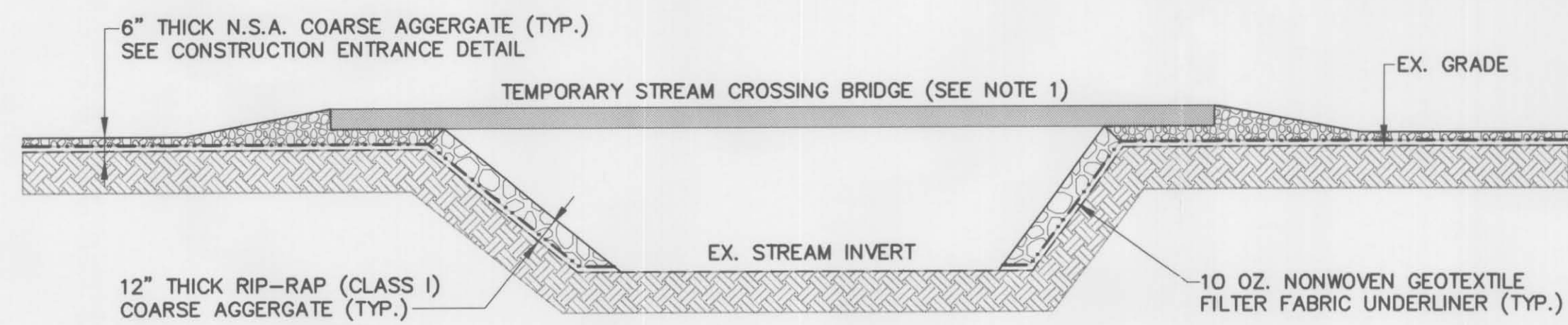

NOTE:

1. TEMPORARY BRIDGES CAN BE CONSTRUCTED FROM WOOD AND LOGS, USED RAILROAD CARS (FLATCARS AND BOXCARS ARE USUALLY 85 FT. IN LENGTH), TRUCK FLAT BEDS (ABOUT 60 FT. IN LENGTH), PORTABLE HINGED BRIDGES, MODULAR STEEL BRIDGES (MADE OF INTERLOCKING PANELS) AND PRESTRESSED CONCRETE PANELS (CAN OFTEN BE PURCHASED USED FROM THE DEPARTMENT OF TRANSPORTATION).

Sb STREAMBANK STABILIZATION
NTS

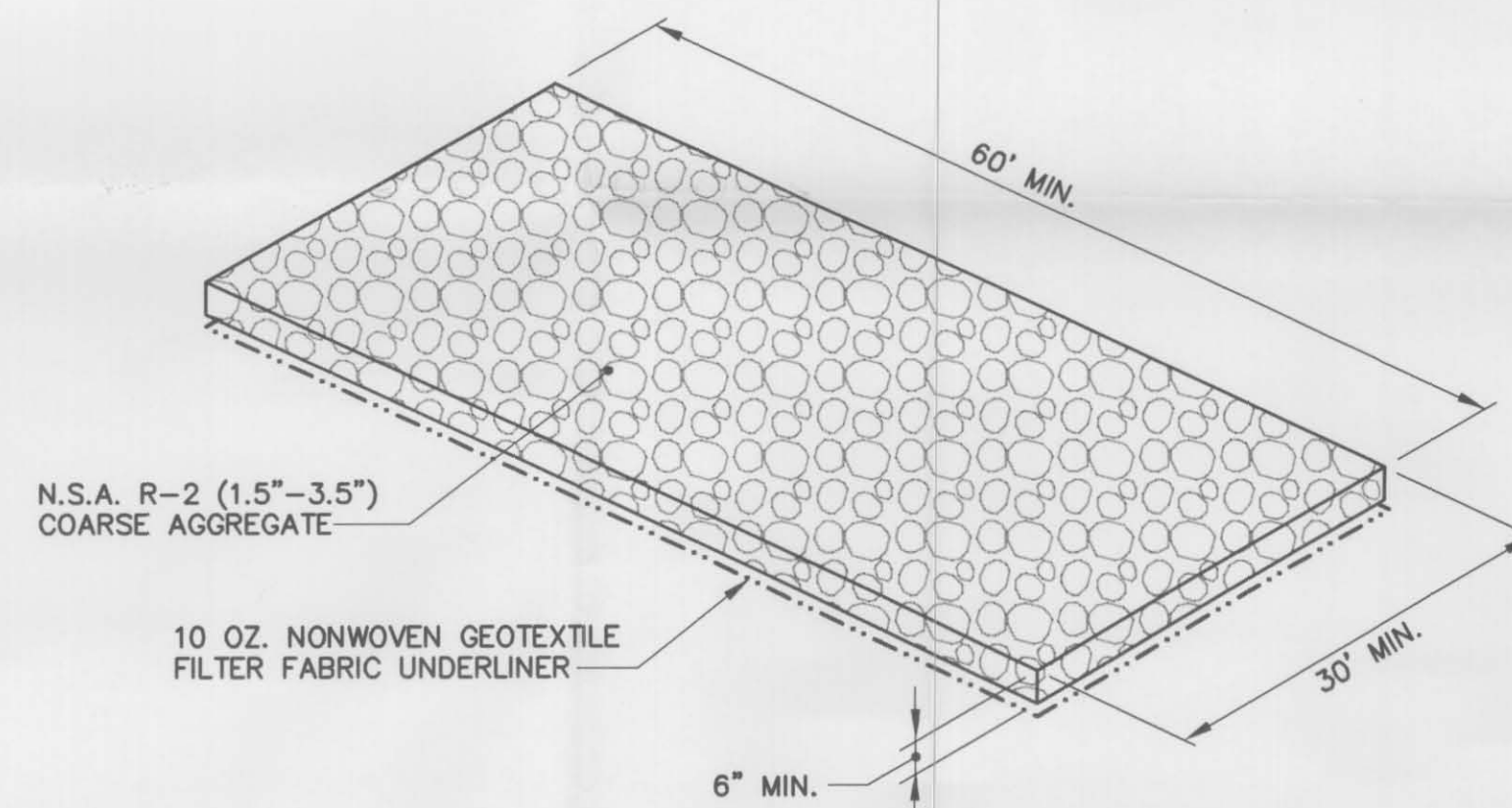

NOTE:

1. THE ENTRANCE/EXIT SHALL BE MAINTAINED IN A CONDITION WHICH WILL PREVENT TRACKING OR FLOW OF MUD ONTO PUBLIC RIGHT-OF-WAY. THIS MAY REQUIRE PERIODIC TOP DRESSING WITH 1.5-3.5 INCH STONE, AS CONDITIONS DEMAND, AND REPAIR AND/OR CLEANOUT OF ANY STRUCTURES TO TRAP SEDIMENT. ALL MATERIALS SPILLED, DROPPED, WASHED OR TRACKED FROM VEHICLES ONTO ROADWAYS OR INTO STORM DRAINS MUST BE REMOVED IMMEDIATELY. UPON COMPLETION OF CONSTRUCTION, STONE AND GEOTEXTILE WILL BE REMOVED.

Co CONSTRUCTION ENTRANCE/EXIT
NTS

GENERAL EROSION AND SEDIMENTATION CONTROL NOTES

1. EROSION AND SEDIMENT CONTROL SHALL BE AS PRESCRIBED IN THE APPROVED BMP AND THE TECHNICAL SPECIFICATIONS FOR THIS PROJECT.
2. THE INSTALLATION OF EROSION AND SEDIMENTATION CONTROL MEASURES AND PRACTICES SHALL OCCUR PRIOR TO OR CONCURRENT WITH LAND DISTURBING ACTIVITIES.
3. EROSION AND SEDIMENTATION CONTROL MEASURES SHALL BE MAINTAINED AT ALL TIMES. ADDITIONAL EROSION AND SEDIMENTATION CONTROL MEASURES AND PRACTICES SHALL BE INSTALLED IF DEEMED NECESSARY BY ON-SITE INSPECTION.
4. TEMPORARY GRASS WILL BE ESTABLISHED ON BARE SOIL WITHIN 14 DAYS OF BEING DISTURBED. ONCE THE CONSTRUCTION IS COMPLETE, PERMANENT GRASS WILL BE ESTABLISHED.
5. EROSION AND SEDIMENTATION CONTROLS SHALL NOT BE REMOVED UNTIL ALL CONSTRUCTION IS COMPLETE AND THE AREA STABILIZED.
6. MAINTENANCE OF ALL SOIL EROSION AND SEDIMENTATION CONTROL MEASURES AND PRACTICES, WHETHER TEMPORARY OR PERMANENT, SHALL BE AT ALL TIMES THE RESPONSIBILITY OF THE CONTRACTOR.

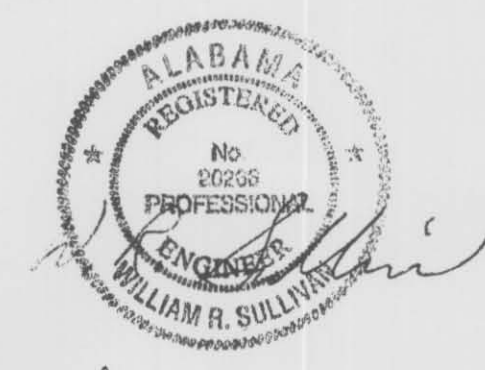

Jan 16, 2003
01/16/03

REV	DATE	DES	REVISION DESCRIPTION	CADD	CHK	RW
-	-	-	-	-	-	-
PROJECT: SOLUTIA INCORPORATED CHOCCOLOCCO CREEK WWTP ANNISTON, ALABAMA						
TITLE: EROSION & SEDIMENTATION CONTROL DETAILS						
PROJECT No. 943-3680		FILE No. 07-EROS-SED-DETAILS				
DESIGN	CMM	12/02	SCALE	AS SHOWN	REV.	-
CADD	RMS	12/02				
CHECK	SJM	01/03				
REVIEW	WRS	01/03				
Golder Associates Atlanta, Georgia						7

Drawn file: 07-EROS-SED-DETAILS.dwg
 Jan 15, 2003 - 10:48am

Appendix C - Technical Specifications

TECHNICAL SPECIFICATIONS

<u>SECTION</u>	<u>TITLE</u>
<u>DIVISION 1 - GENERAL REQUIREMENTS</u>	
01050	Surveying
01400	Quality Control
01540	Jobsite Security
01562	Dust Control
01564	Health and Safety Plan
<u>DIVISION 2 - SITE WORK</u>	
02104	Temporary Stream Crossing
02105	Erosion and Sediment Control
02110	Site Clearing, Grubbing and Topsoil Stripping
02221	Earthworks
02230	Rip Rap
02235	Toe Drain Materials
02267	Soil and Topsoil Cover Materials
02310	HDPE Geomembrane
02320	Geocomposite Drainage Net
02330	Geotextile
02431	Decontamination
02525	Access Road Construction
02936	Grassing and Mulching

TECHNICAL SPECIFICATION

SECTION 01050 - SURVEYING

PART 1 GENERAL

1.1 DESCRIPTION OF WORK

- A. The Contractor shall be responsible for providing surveying services for accurate location of all features of construction and for establishing all proposed grades. The Contractor shall be responsible for all surveys and calculations for layout of the Work, measurements for payment quantities, verification of grades, verification of the thickness of layers/lifts, and the preparation and maintenance of project As-Built Drawings.
- B. The Contractor shall employ a Land Surveyor registered in the State of Alabama and acceptable to the Construction Manager.
- C. The Contractor shall submit evidence of the Surveyor's errors and omissions insurance coverage in the form of an Insurance Certificate with limits as specified in the Contract Documents.
- D. The Contractor shall make all measurements and check all dimensions necessary for the proper performance of the Work in accordance with the Contract Documents. During the execution of the Work, the Contractor shall make all necessary measurements to ensure the accurate performance of the Work.
- E. The Contractor shall be responsible for submitting survey information to be used by the Construction Manager and Owner in verifying payment quantities.
- F. The Owner may retain a Alabama registered Land Surveyor to independently verify survey lines and grades and payment quantities. In the event of a discrepancy, the surveyor retained by the Owner will govern. The Contractor and the Contractor's surveyor shall be responsible for cooperating with the surveyor retained by the Owner and for submitting copies of any survey calculations and data, if required, to the Construction Manager. No separate payment shall be made for cooperating with the surveyor or providing copies of survey calculations.

1.2 QUALITY CONTROL

- A. The Contractor's surveyor shall be a qualified and registered Land Surveyor in the State of Alabama. This surveyor shall have a minimum of five (5) years experience in construction surveying layout and maintenance of as-built construction Drawings with a record of performing horizontal and vertical control requirements as stated in the Contract.
- B. All surveying personnel who may come in contact with waste and/or may work within excavations must have, at a minimum, training in accordance with 29 C.F.R. 1910.120.

TECHNICAL SPECIFICATION

SECTION 01050 - SURVEYING

1.3 SUBMITTALS

- A. The Contractor shall submit for approval by the Construction Manager the name, address, and telephone number of the Surveyor prior to initiation of any survey work.
- B. The Contractor shall submit documentation verifying the accuracy of the survey and the Work to Construction Manager upon request.
- C. The Contractor's Surveyor shall submit sealed and signed As-Built Drawings and survey notes, which state that the elevations and locations of Site-constructed features are in conformance with the Contract Documents, to the Construction Manager at the completion of each phase of the Work requiring the services of the Surveyor.
- D. No Work shall be covered until the as-built surveying has been performed. If the Work has been covered before the survey has been completed, that portion of the Work will be uncovered, surveyed, and reconstructed at the Contractor's expense.

1.4 PROJECT RECORD DOCUMENTS

- A. The Contractor shall prepare and submit Project Record Documents to the Construction Manager.
- B. A complete, accurate log of control and survey work, as it progresses, shall be maintained at the Site by the Contractor and submitted to the Construction Manager upon request.
- C. Upon completion of the Work, a complete set of Record Documents must be submitted by the Contractor to the Construction Manager for review and acceptance. Copies of all required survey data, calculations, and summary tables, sealed and signed by the Surveyor, shall be submitted.

1.5 SURVEY REQUIREMENTS

- A. Provide field-engineering services using recognized engineering survey practices.
- B. Establish line and grade as required to complete the Work. Identify, locate and/or layout the following:
 - 1. Existing underground pipes and/or structures located in such manner as to affect any portion of the Work. Include depths to pipe.
 - 2. Line and grade for measurement and payment purposes (i.e., determination of in-place quantities). The Contractor shall provide

TECHNICAL SPECIFICATION

SECTION 01050 - SURVEYING

sufficient survey to verify the quantities included in Applications for Payment.

3. As-Built survey information shall include, but not be limited to, the following:
 - a) The subgrade elevations at a contour interval of 0.25 feet on a 50-foot grid;
 - b) The top of PCB-containing soil elevation at a contour interval of 0.5-foot a 50-foot grid to a tolerance of ± 0.1 foot;
 - c) The finished grade elevations at a contour interval of 0.5 feet on a 50-foot grid to a tolerance of ± 0.1 foot on a 50-foot grid;
 - d) Other visible features in the construction area;
 - e) Regrading activities to verify fill grades, fill thickness, and fill extent.

PART 2 PRODUCTS

Not Used.

PART 3 EXECUTION

3.1 INSPECTION

- A. All surveys for this Contract must use, and be referenced to, the coordinate system (Northing, Easting, and elevation), which is shown on the Drawings.
- B. Survey control points, providing horizontal and vertical control in the vicinity of the Fill Areas, will be provided by the Construction Manager.
- C. The Contractor shall verify the locations of the Site reference and survey control points prior to starting the Work. The Construction Manager must be promptly notified of any discrepancies discovered by the Contractor.

3.2 SURVEY REFERENCE POINTS

- A. The Contractor shall take measures to protect Site reference and survey control points prior to starting the Work, and must preserve permanent reference points throughout construction. Site reference and survey control points may not be relocated without prior written notice by the Construction Manager.
- B. The Construction Manager shall be immediately notified of loss, damage or destruction of any reference point, or relocation required because of changes in

TECHNICAL SPECIFICATION

SECTION 01050 - SURVEYING

grades or other reasons. The Contractor shall replace disturbed survey control points based on original survey control at the Contractor's own expense.

- C. All horizontal and vertical control coordinates (i.e., Northings, Eastings, and elevations) of benchmarks and survey control points shall be determined (and recorded) with a maximum permissible error of ± 0.10 foot in any horizontal coordinate and ± 0.01 foot in any vertical coordinate.
- D. All horizontal and vertical control coordinates are to be referred to the Alabama State Plane Coordinate System and referred to the nearest USGS benchmark, respectively.
- E. Survey and clearly mark the limits of all Work areas.

3.3 SURVEY REQUIREMENTS

- A. The Contractor shall reference all survey and data reference points to permanent benchmarks and record the locations of survey control points, with horizontal and vertical data, on the Project Record Documents.
- B. The Contractor shall re-verify layouts periodically during construction by the same means as the original layout.
- C. Pre-construction surveys shall be performed in the construction area to establish baseline grade elevations. Surveys shall be performed prior to the staging of materials or equipment, and grade stakes shall be used to control relocation and consolidation of the soils.

END OF SECTION

TECHNCIAL SPECIFICATION

SECTION 01400 -- QUALITY CONTROL

PART 1 GENERAL

1.1 DESCRIPTION OF WORK

- A. The Work under this Section includes the Contractor's responsibility for providing Quality Control testing and inspection necessary for the proper and complete performance of the Work.
- B. The Contractor shall comply with the Quality Control testing and inspection requirements herein, in the Construction Quality Assurance Plan (CQAP), and as otherwise specified in individual Sections of these Specifications for the Work.

1.2 RELATED SECTIONS

- A. Erosion and Sedimentation Control – Section 02105
- B. Earthworks– Section 02221
- C. Soil and Topsoil Cover Materials – Section 02267
- D. Rip-Rap – Section 02230
- E. HDPE Geomembrane - Section 02310
- F. Geocomposite Drainage Net - Section 02320
- G. Geotextile – Section 02330

1.3 QUALITY CONTROL OF INSTALLATION

- A. The Contractor shall monitor and provide quality control testing over earthworks, geosynthetic products, services, Site conditions, and workmanship for conformance with the Contract Documents.
- B. The Contractor shall hire a third party Quality Control professional to provide geotechnical field and laboratory testing of the earthworks, as required herein.
- C. The Contractor shall comply fully with manufacturers' instructions, including each step in sequence.
- D. Should the manufacturers' instructions conflict with the Contract Documents, the Contractor shall request clarification from the Construction Manager before proceeding.
- E. The Contractor shall comply with specified standards as a minimum quality for the Work except when more stringent tolerances, codes, or specified requirements indicate higher standards or more precise workmanship.

TECHNCIAL SPECIFICATION

SECTION 01400 -- QUALITY CONTROL

- F. The Contractor shall perform Work with persons qualified to produce workmanship of specified quality.

1.4 REFERENCES

- A. Conform to the reference standard that is in effect as of the date for receiving bids.
- B. Obtain copies of specified standards when required by the Contract Documents.
- C. Should specified reference standards conflict with the Contract Documents, request clarification from the Construction Manager before proceeding.
- D. The contractual relationship of the parties to the Contract shall not be altered from the Contract Documents by either mention or inference in any reference document.
- E. Quality Control shall be independently provided by the Contractor as per the requirements of this Section of the Specifications and the CQAP for the Work.
- F. Quality Assurance shall be independently provided by the Owner as per the CQAP for the Work.

1.5 INSPECTION AND TESTING LABORATORY SERVICES

- A. The Contractor is responsible for performing, documenting, and certifying all Quality Control tests.
- B. The Contractor will perform inspections, tests, and services as required by these Specifications.
- C. Reports will be submitted by the Contractor to the Construction Manager, indicating observations and results of tests and indicating compliance or non-compliance with the Contract Documents.
- D. The Contractor, when required, shall cooperate with the Construction Manager and the Quality Assurance Official to furnish samples of materials, equipment, tools, storage and assistance as requested.
 - 1. Notify the Quality Assurance Official twenty-four (24) hours prior to the expected time for operations requiring services.
 - 2. Arrange with the Quality Assurance Official and pay for additional samples and tests required for the Contractor's use.
- E. Re-testing or re-inspection required because of non-conformance to the specified requirements shall be performed by the Contractor on instructions by the Construction Manager. The cost of re-testing and re-inspection resulting from

TECHNCIAL SPECIFICATION

SECTION 01400 -- QUALITY CONTROL

non-conformance with the Technical Specifications shall be the responsibility of the Contractor.

PART 2 PRODUCTS

Not Used.

PART 3 EXECUTION

Not Used.

*****END OF SECTION*****

TECHNICAL SPECIFICATION

SECTION 01540 -- JOB SITE SECURITY

PART 1 GENERAL

1.1 DESCRIPTION OF WORK

- A. The Contractor shall be responsible for all job site security. Whenever evidence is found of damage to the Work, the Contractor shall immediately remove the damaged portion and replace it with satisfactory Work at the Contractor's expense. A copy of all accident reports shall be submitted to the Construction Manager and the Owner within twenty-four (24) hours or the next business day.
- B. The Contractor shall keep a daily record of personnel and visitors on-site including arrival and departure times. Provide records to the Construction Manager on a weekly basis.
- C. The Contractor's responsibility for the maintenance of job Site security shall not cease until the Work has been accepted by the Owner.

1.2 BARRICADES, LIGHTS, AND SIGNALS

- A. The Contractor shall furnish and erect such barricades, fences, flagmen, watch guards, lights, and danger signals, and shall provide such other precautionary measures to protect persons, property, and the Work as necessary to comply with Federal, State, and local regulations. Barricades shall be painted in a color or utilize other measures to ensure visibility at night. From sunset to sunrise, the Contractor shall furnish and maintain at least one operable light at each barricade, and sufficient numbers of barricades shall be erected to keep vehicles from being driven on, and persons from walking under or into, construction areas.
- B. Damage to the Work due to failure of barricades, signs, and lights is the sole responsibility of the Contractor, and whenever evidence is found of such damage to the Work, the Contractor shall immediately remove the damaged portion and replace it at Contractor's expense. The Contractor's responsibility for the maintenance of barricades, signs, and lights shall not cease until the Owner has accepted the Work.
- C. The Contractor shall control vehicle access when the Work is in progress. At the end of each workday, the Contractor shall secure access to the fills and provide security as specified herein.

1.3 SITE ACCESS AND RESTRICTIONS

- A. Immediately following issuance of the Notice to Proceed, the Contractor shall assume the responsibility and cost of Site security through the completion of the Work, including periods of no construction activity. This includes, but is not limited to, access control, installation of temporary protective fencing and gates (as required), fence inspection and repair, barricades around excavated areas,

TECHNICAL SPECIFICATION

SECTION 01540 -- JOB SITE SECURITY

and other necessary measures to restrict public access to these designated areas until the Work is completed.

- B. The Contractor shall coordinate with the Construction Manager to establish guidelines for personnel access to the Site.

PART 2 PRODUCTS

Not Used.

PART 3 EXECUTION

Not Used.

*****END OF SECTION*****

TECHNICAL SPECIFICATIONS

SECTION 01562 -- DUST CONTROL

PART 1 GENERAL

1.1 DESCRIPTION OF WORK

- A. The Contractor shall employ means and methods that keep airborne particles to the minimum and shall provide all labor, equipment, machinery, and materials for the application of water or other appropriate preventative means or methods to maintain dust control in accordance with the Site-specific Dust Control Plan and subject to favorable review by the Construction Manager.
- B. The Contractor shall comply will all applicable codes, ordinances, rules, regulations and laws of local, municipal, State, and Federal authorities having jurisdiction.
- C. The Contractor shall provide a "Competent Person" to implement, supervise, and inspect all Work. The Construction Manager shall monitor satisfactory implementation of the Work.

1.2 HEALTH AND SAFETY

- A. Site workers shall not be exposed to respirable particles caused by the performance of the Work in excess of applicable Federal and State standards.
- B. Airborne particles shall be monitored in accordance with the Site-specific Health and Safety Plan and the requirements of Section 01564 of these Specifications.

PART 2 PRODUCTS

2.1 GENERAL

- A. The use of calcium chloride for dust control is not permitted on the Site.

PART 3 EXECUTION

3.1 GENERAL

- A. Watering equipment shall be used to minimize airborne particulate concentrations and shall consist of pipelines, tank trucks, or other devices acceptable to the Construction Manager, which are capable of applying a uniform spread of water over the ground surface. A suitable device for a positive shut-off and for regulating the flow rate of water shall be located so as to permit positive operator control.
- B. Potable water shall be used for dust control. The Contractor shall provide the name and location of the water source, and evidence that the water is potable, to

TECHNICAL SPECIFICATIONS

SECTION 01562 -- DUST CONTROL

the Construction Manager. Non-potable water may only be used if approved by the Construction Manager.

- C. Dust control shall be applied immediately when conditions warrant. A sufficient quantity of potable water shall be maintained on-site for immediate dust control use.

*****END OF SECTION*****

TECHNCIAL SPECIFICATION

SECTION 01564 -- HEALTH AND SAFETY PLAN

PART 1 GENERAL

1.1 PURPOSE

- A. The purpose of Section is to establish minimum health and safety requirements for the Contractor to satisfy in the preparation of the Contractor's Site-Specific Health and Safety and Contingency Plan.

1.2 APPLICABILITY

- A. These requirements shall be used by the Contractor's Site Health and Safety Officer (Contractor's SHSO) to assist in preparation of the Contractor's Site-specific Health and Safety and Contingency Plan (HASCP). These requirements shall not relieve the Contractor from compliance with any applicable State, Federal, or other health and safety requirements and safe construction practices even if not specifically identified in these requirements. These requirements shall not relieve the Contractor's complete responsibility for the Site's safety and security, including Health and Safety.
- B. If, at any time, the Construction Manager is apprised of a safety hazard which demands immediate attention because of its high potential for harm to public travel, persons on or about the Work, or public or private property, the Construction Manager shall have the right to order such safeguards to be erected and such precautions to be taken as necessary and the Contractor shall comply with such orders.
- C. If, under such circumstances, the Contractor does not or cannot immediately put the Work into proper and approved condition, or if the Contractor or his representative is not upon the Site so that he can be notified immediately of the insufficiency of safety precautions, then the Construction Manager may put the Work into such a condition that it shall be, in his opinion, in all respects safe, and the Contractor shall pay all costs of such labor and materials. The fact that the Construction Manager does not observe a safety hazard or does not order the Contractor to take remedial measures shall in no way relieve the Contractor of the entire responsibility for any costs, loss, or damage by any party sustained on account of the insufficiency of the safety precautions taken by the Contractor or by the Construction Manager acting under authority of this Section.
- D. It is the responsibility of the Contractor to take appropriate safety precautions to meet whatever conditions of hazard may be present during the performance of the Work, whether the hazard may or may not be reasonably foreseeable. The Contractor is alerted to the fact that it shall be his responsibility to anticipate and provide such additional safety precautions, facilities, personnel, and equipment as shall be necessary to protect life and property from whatsoever conditions of hazard are present or may be present.

TECHNCIAL SPECIFICATION

SECTION 01564 -- HEALTH AND SAFETY PLAN

1.3 MINIMUM REQUIREMENTS

- A. The Contractor shall prepare and implement a Site-specific HASCP that shall conform with applicable State and Federal requirements, including, but not limited to:
1. Safety and Health Regulations promulgated by the U.S. Department of Labor: 29 CFR Part 1904 - Recording and Reporting Occupational Injuries and Illness, 29 CFR Part 1910 - Occupational Safety and Health Standards, and 29 CFR Part 1926 - Safety and Health Regulations for Construction.
 2. U.S. Environmental Protection Agency Interim Standard Operating Safety Guides - Office of Emergency and Remedial Response - Hazardous Response Support Division, Rev. September 1982.
 3. U.S. Environmental Protection Agency Medical Monitoring Program Guidelines.
- B. The Contractor shall incorporate, as part of the Site-specific HASCP, the requirements from the Health and Safety Plan Guidelines included in the Corrective Measures Plan.
- C. The Site-specific HASCP shall be prepared by the Contractor's SHSO, who shall be a Certified Industrial Hygienist and shall have experience with establishing and implementing health and safety plans for hazardous waste site remediation projects. The resume of the Contractor's SHSO shall be included in the Contractor's Bid and bound with the Contractor's HASCP.
- D. The Contractor's HASCP shall incorporate the requirements contained herein and shall describe all actions to be taken to protect the health and safety of workers and the surrounding community. The plan shall identify all tasks to be undertaken by the Contractor and shall establish health and safety procedures for each task. The Contractor's HASCP shall be approved in writing by the Contractor's SHSO and shall be submitted to the Construction Manager, Owner, and the USEPA prior to the initiation of any fieldwork. Any modifications to the HASCP shall also be submitted to the Construction Manager prior to construction. The Construction Manager may comment on the Contractor's Site-specific HASCP and any modifications thereto, but will not provide approval of the Site-specific HASCP.
- E. Training requirements of all field personnel shall be specified in the Site-specific HASCP. As a minimum, training in accordance with 29 CFR 1910.120 should be required for all personnel involved in intrusive activities (i.e., all below grade work and all grading and handling of soil or waste materials) and until all construction and testing of the cap components is satisfactorily completed. Such training should also be required, at a minimum, for all crews who could be exposed to potentially hazardous materials during tie-ins, connections, and testing.

TECHNCIAL SPECIFICATION

SECTION 01564 -- HEALTH AND SAFETY PLAN

- F. To assist in preparation of the Site-specific HASCP, the Contractor is encouraged to review existing Site documents included in the CMI Work Plan.

PART 2 PRODUCTS

Not Used.

PART 3 EXECUTION

3.1 RECORDKEEPING

- A. All parties engaged in on-Site activities shall read the Contractor's Site-specific HASCP for the relevant tasks. Documentation demonstrating compliance with this requirement shall be maintained on-Site by the Contractor. Written evidence of compliance with 29 CFR 1910.120 and applicable State and Federal requirements, for all parties engaged in on-Site activities, shall be maintained on-Site in the Contractor's files. Copies of such documentation shall be provided to the Construction Manager.

END OF SECTION

TECHNICAL SPECIFICATION

SECTION 02104 - TEMPORARY STREAM CROSSING

PART 1 GENERAL

1.1 DESCRIPTION OF WORK¹

A. General

1. Contractor shall install a temporary bridge structure across Snow Creek, at the location shown on the Construction Drawings, for short-term use by construction vehicles and heavy equipment to prevent damage to the watercourse or the deposition of sediment into the watercourse.
2. In-stream work should be performed in dry weather conditions. Clearing of the streambed and banks shall be kept to a minimum. No excavation of the streambanks/abutments shall be permitted without prior approval from the Construction Manager.
3. The stream banks in the area of the stream crossing shall be lined with geotextile and coarse aggregate or otherwise appropriately stabilized.
4. The crossing alignment shall be at right angles to the stream, and the travel way for all structures shall be minimum 15-feet wide.
5. If the slope above the stream banks is more than 2 percent, a diversion dike shall be placed above the stream banks to divert surface runoff away from the disturbed channel section and discharge the runoff to a stable outlet.

B. Temporary Bridge

1. The Contractor shall be responsible for the proper design and installation of the temporary bridge.
2. The temporary bridge shall be prefabricated and consist of wood, concrete, or metal designed to support the maximum expected load.
3. The bridge shall be securely anchored at one end using steel cable or chain. Anchoring shall prevent the bridge from floating downstream.

C. Bridge Approach/Abutments

1. The approach/abutments shall be covered with a minimum 12 inches of coarse aggregate fill.
2. Filter fabric (per Section 02330 of these Specifications) shall be placed on the stream banks before placement of the coarse aggregate. The filter fabric shall cover the banks and extend 36 inches beyond the toe of the banks.

¹ This section of the Specifications will be deleted if the Anniston Water and Sewer Board elect to construct a permanent bridge across Snow Creek prior to commencement of the Work.

TECHNICAL SPECIFICATION

SECTION 02104 - TEMPORARY STREAM CROSSING

1.2 SUBMITTALS

- A. The Contractor shall submit the proposed design for the temporary crossing, including proposed installation procedures to the Construction Manager for approval a minimum of fifteen (15) days prior to the commencement of construction activities.

PART 2 PRODUCTS

2.1 TEMPORARY STREAM CROSSING

- A. Temporary bridges:
1. Pre-fabricated wood, concrete or steel.
 2. Potential Bridge suppliers:

<u>TYPE OF BRIDGE</u>	<u>COMPANY</u>	<u>CONTACT</u>
a) Steel - flatcar	Rick Frankling Corporation	John Stolsig, 541- 451-1275
b) Steel – Bailey Bridge	Bailey Bridge, Inc.	Bob Love, 1-800-477 7320
c) Steel	Mabey Bridges and Shore, Inc.	Kevin Traynor, 1-800-426-2239
d) Timber	York Bridge Concepts	Cave Caldarola 1-800-226-4178
e) Timber/ Composite	Hughes Brothers	Larry D. Vandergriend, P.E., 402-643-2991
f) Stone/Concrete	Echo Bridge, Inc.	1-888-327-4343

- B. Coarse Aggregate fill
1. For approach use NSA R-2, 1.5 inches to 3.5 inches, AHD No. 1 Stone or equivalent.
 2. For stream bank slopes use Class I Rip-Rap, per Section 02230 of these Specifications.
- C. Filter fabric
1. Non-woven Geotextile, per Section 02330 of these Specifications.

TECHNICAL SPECIFICATION

SECTION 02104 - TEMPORARY STREAM CROSSING

PART 3 EXECUTION

3.1 GENERAL

- A. Install temporary stream crossing without disturbing the stream banks and without causing sediment to flow into Snow Creek.
- B. Conduct earthwork and excavation activities in such a manner to fit the topography, soil type, and soil conditions.
- C. Minimize the area being disturbed and the duration of exposure to erosion elements.
- D. Stabilize disturbed areas immediately.
- E. Retain on-Site, sediment that was generated on-Site.
- F. Prevent silt and sediment from entering Snow Creek if soil erosion cannot be prevented.
- G. Where provisions of pertinent rules and regulations conflict with these Specifications, the more stringent provisions shall govern.
- H. The Construction Manager has the authority to limit the surface area of erodible material exposed by clearing and grubbing, and to direct the Contractor to provide immediate temporary or permanent control measures to prevent sediment impacts on adjacent creeks.

END OF SECTION

TECHNICAL SPECIFICATION

SECTION 02105 -- EROSION AND SEDIMENTATION CONTROL

PART 1 GENERAL

1.1 DESCRIPTION OF WORK

- A. The Contractor shall provide all materials and promptly take all actions necessary to achieve effective erosion and sedimentation control in accordance with all applicable Federal, State, and local enforcing agency guidelines and these Specifications. Some of the contents of this Section may not be directly applicable to this Work, but are included as a contingency if unanticipated circumstances occur.
- B. The Contract Documents shall be considered minimum requirements for erosion and sedimentation control and shall not relieve the Contractor of the responsibility to actively take all steps necessary to control soil erosion and sedimentation in all areas associated with the Work. The Contractor shall provide a "Competent Person" to implement, supervise, and inspect all erosion and sediment control work.
- C. The Contractor shall comply with applicable codes, ordinances, rules, regulations, and laws of local, municipal, State or Federal authorities having jurisdiction.
- D. The Contractor must adhere to the Best Management Practices Plan (BMP) and the Erosion and Sediment Control Plan included in the Contract Drawings.
- E. The Contractor and the Construction Manager shall work together with regulatory agencies, and other experts as directed by the Construction Manager, attend meetings as necessary, and answer all questions/comments to the satisfaction of the regulators.
- F. The Contractor shall repair and/or replace any materials damaged by erosion or covered with sedimentation, at no additional cost to the Owner.
- G. The Contractor shall maintain temporary erosion control features installed by the Contractor until no longer needed and as determined by the Construction Manager, or permanent erosion control methods are installed/established.
- H. It shall be the sole responsibility of the Contractor to schedule properly and coordinate all necessary labor, equipment, and materials such that the specified Work is performed in accordance with the Construction Schedule and the Contract requirements. The Construction Manager may reject or direct the Contractor to repair, at the Contractor's own expense, those items which are detrimental to the Work or not in compliance with the Contract Documents. Such direction or rejection by the Construction Manager shall not relieve the Contractor of his obligation to properly schedule and perform other specified Work items in conformance with the Contract Documents.

TECHNICAL SPECIFICATION

SECTION 02105 -- EROSION AND SEDIMENTATION CONTROL

1.2 SUBMITTALS

- A. The Contractor shall submit manufacturer's material data sheets and guidelines for installation of silt fence and other manufactured erosion and sediment control devices as necessary for the Work.

PART 2 PRODUCTS

2.1 SILT FENCE

- A. Silt fences shall be a woven geotextile attached to wooden or steel posts as detailed on the Construction Drawings or as recommended by the manufacturer.

2.2 BALES

- A. Straw bales shall be clean, seed-free oat or wheat types.

2.3 FERTILIZER /SEEDING/ MULCH

- A. In accordance with Section 02936 of these Specifications.

2.4 WATER

- A. Clean, fresh, potable water shall be free of substances or matter that could inhibit vigorous growth of grass.

2.5 RIP-RAP

- A. Rip-rap shall be as defined in Section 02230 of these Specifications.

PART 3 EXECUTION

3.1 GENERAL

- A. Conduct earthwork and excavation activities in such a manner to fit the topography, soil type, and soil conditions.
- B. Minimize the area being disturbed and the duration of exposure to erosion elements.
- C. Stabilize disturbed areas immediately.
- D. Retain on-Site, sediment that was generated on-Site.

TECHNICAL SPECIFICATION

SECTION 02105 -- EROSION AND SEDIMENTATION CONTROL

- E. Prevent silt and sediment from entering the Snow Creek if soil erosion cannot be prevented.
- F. Where provisions of pertinent rules and regulations conflict with these Specifications, the more stringent provisions shall govern.
- G. The Construction Manager has the authority to limit the surface area of erodible material exposed by clearing and grubbing, and to direct the Contractor to provide immediate temporary or permanent control measures to prevent sediment impacts on adjacent Creeks.
- H. Where erosion is likely to be a problem, clearing and grubbing operations should be scheduled and performed that such grading operations and permanent erosion control features can follow immediately thereafter, if the Work conditions permit; otherwise, erosion control measures may be required between successive construction stages. Under no conditions shall the total aggregate surface area of erodible material (such as exposed soil, erodible material without vegetation, or erosion protection) exposed at one time by clearing and grubbing, exceed three (3) acres without approval by the Construction Manager.
- I. In the event that additional temporary erosion and sedimentation control measures are required due to the Contractor's negligence, carelessness or failure to install permanent controls as a part of the Work schedule, or are ordered by the Construction Manager, such Work shall be performed by the Contractor, at no additional cost to the Owner, and no time extensions shall be granted.

3.2 TEMPORARY EROSION AND SEDIMENTATION CONTROL

- A. Temporary erosion control measures shall be used to correct conditions that develop during construction and lead to soil erosion or deposition of waterborne sediments; that are needed prior to installation of permanent erosion control features; or that are needed temporarily to control erosion that develops during normal construction practices, but are not associated with permanent control features for the Work.
- B. Temporary erosion and sedimentation control devices shall be installed and maintained prior to initial land disturbance activities and until satisfactory completion or establishment of permanent erosion control measures. At that time, temporary measures shall be removed.
- C. The Contractor shall coordinate the installation of temporary erosion and sedimentation control provisions contained herein with the permanent erosion control features, to ensure economical, effective and continuous erosion control throughout the construction and post-construction period.
- D. Temporary erosion and sedimentation control procedures should be initially directed toward preventing silt and sediment from entering Snow Creek and Choccolocco Creek. The preferred method is to provide an undisturbed natural

TECHNICAL SPECIFICATION

SECTION 02105 -- EROSION AND SEDIMENTATION CONTROL

buffer, extending a minimal 5 feet from the top of the Creek's bank, to filter the run-off.

- E. Silt fences, barriers, and other temporary measures shown on the Erosion and Sediment Control Plan shall be installed as indicated and shall be maintained until no longer needed or as determined by the Construction Manager. At that time, the Contractor shall remove the items. All temporary items and devices must be removed with the approval of the Construction Manager prior to final demobilization from the Site.
- F. Where permanent vegetation is not appropriate and where the Contractor's temporary erosion and sedimentation control practices are inadequate, the Contractor shall provide a temporary vegetative cover.
- G. All erosion and sedimentation control devices shall be inspected by the Contractor at least weekly, after each rainfall occurrence, cleaned out, and repaired by the Contractor, as necessary.

3.3 PERMISSIBLE TEMPORARY EROSION AND SEDIMENT CONTROL TECHNIQUES

- A. Temporary Slope Drains
 - 1. A temporary slope drain may consist of stone downchutes, fiber mats, plastic sheets, half-round pipe, metal pipe, plastic pipe, sod or other material acceptable to the Construction Manager that may be used to carry water down slopes to reduce erosion prior to installation of permanent facilities or growth of adequate ground cover on slopes.
 - 2. Fiber matting and plastic sheeting shall not be used on slopes steeper than 4H: 1V except for short downslope distances of 20 feet or less.
 - 3. All temporary slope drains shall be adequately anchored to the slope to prevent disruption by the force of the water flowing in the drains. The base of temporary slope drains shall be compacted and concavely formed to channel water or hold the slope drain in place. The inlet end shall be properly constructed to channel water into the temporary slope drain.
 - 4. Energy dissipaters, sediment control structures, or other approved devices shall be constructed at the outlet end of the slope drains to reduce erosion downstream.
- B. Rip-rap
 - 1. Unless shown otherwise on the Construction Drawings, stone rip-rap shall be placed where ordered by the Construction Manager and at all points where banks of streams or drainage ditches are disturbed by excavation. Fill or backfill shall be carefully compacted and stone rip-rap placed to prevent subsequent settlement and erosion. This

TECHNICAL SPECIFICATION

SECTION 02105 -- EROSION AND SEDIMENTATION CONTROL

requirement applies equally to construction alongside a stream or drainage ditch as well as crossing a stream or drainage ditch.

C. Straw Bales

1. Straw bales are temporary measures to control erosion and retain the suspended silt particles in the runoff water leaving disturbed areas. Bales shall contain five cubic feet or more of material.
2. Straw bales shall be embedded in the ground four (4) to six (6) inches to prevent water flowing under them. The bales shall also be anchored securely to the ground by wooden stakes driven through the bales into the ground, as indicated on the Construction Drawings. Bales shall be removed after they have served their purpose, as determined by the Construction Manager.
3. The Contractor shall keep the bales in good condition by replacing broken or damaged bales immediately after damage occurs. Normal debris clean out will be considered routine maintenance.
4. Straw bales shall be used at the toe of fill slopes, in ditches, or other areas where siltation, erosion, or water run-off is a problem.
5. Bales shall be placed so that the predominant direction of the straw stalk is oriented perpendicular to the surface water flow direction.

D. Silt Fences

1. Silt fences are temporary measures utilizing woven wire or other approved materials attached to posts with filter cloth attached to the upstream side of the fence to retain the suspended silt particles in the runoff water.
2. Temporary silt fences shall be placed on the natural ground, at the toe of fill slopes, in ditches around soil stockpiles or other areas where siltation, erosion, or water run-off is a problem. Temporary silt fences shall be anchored as indicated on Construction Drawings.
3. The Contractor shall be required to maintain silt fences in a satisfactory condition for the duration of the Work or until its removal is requested by the Construction Manager. The silt accumulation at the fence must be removed and placed on-Site as directed by the Construction Manager.

E. Temporary Vegetation

1. Temporary vegetation measures consist of seeding, mulching, fertilizing, and matting utilized to reduce erosion. All cut and fill slopes shall be seeded when and where necessary to eliminate erosion. Disturbed or bare soil areas shall not be left without stabilization for more than ten (10) days.

TECHNICAL SPECIFICATION

SECTION 02105 -- EROSION AND SEDIMENTATION CONTROL

2. Seeding, fertilizing, and mulching shall be performed in accordance with Article 2.3 of this Section.
3. If late fall completion prevents germination, disturbed areas shall be protected by installing a long-term erosion control mat (Bon Terra CS2, or approved equal).

3.4 PERMANENT EROSION AND SEDIMENT CONTROL

- A. The Contractor shall incorporate all permanent erosion control features into the Work at the earliest practicable time as outlined in the Contractor's accepted Construction Schedule or as land disturbance for each segment of the Work has been completed.
- B. Restore the Site to its original contours, unless otherwise shown on the Construction Drawings or as directed by the Construction Manager.
- C. When final grades have been established, all bare soil, unless otherwise required by the Contract Documents, shall be seeded, fertilized, and mulched in an effort to restore to a protected condition. Areas that are not successfully stabilized with seed and mulch within 30 days of seeding shall be reseeded at the Contractor's own expense to the satisfaction of the Construction Manager.
- D. Specified permanent vegetation shall be established at the first appropriate season following establishment of final grading in each section of the Site.
- E. Permanent vegetative cover activities shall comply with local soil and water conservation guidelines.
- F. Where permanent vegetative cover cannot be immediately established (due to season or other circumstances) the Contractor shall provide temporary vegetative cover.

3.5 PERMANENT EROSION AND SEDIMENT CONTROL TECHNIQUES

- A. Permanent Vegetation: All references to permanent vegetation, unless noted otherwise, shall relate to establishing permanent vegetative cover and be in accordance with Article 2.3 of this Section. Initial seeding of permanent vegetation shall occur within ten (10) days of final grading. Permanent vegetation will require a stand of growth of at least 75%, within one (1) year of the initial seeding, or the Contractor shall re-seed at no cost to the Owner. The Contractor, at the direction of the Construction Manager, shall selectively cut the established first growth after one (1) year.

END OF SECTION

TECHNCIAL SPECIFICATION

SECTION 02110

SITE CLEARING, GRUBBING AND TOPSOIL STRIPPING

PART 1 GENERAL

1.1 DESCRIPTION OF WORK

- A. The Work consists of providing labor, materials, services, equipment, and transportation required to clear the construction area, including the existing soil stockpile.
- B. The Work includes selective grubbing and does NOT include any topsoil removal from the project site.
- C. The Work also includes the removal and disposal at a Subtitle D Facility of the plastic material currently covering the existing stockpile.
- D. The Contractor shall comply with applicable codes, ordinances, rules, regulations, and laws of local, municipal, State or Federal authorities having jurisdiction.
- E. No clearing or grubbing operations shall be allowed without adequate erosion and sedimentation control measures in-place to the satisfaction of the Construction Manager in accordance with Section 02105 of these Specifications, the Site-specific BMP Plan and as described in the Construction Drawings.

1.2 DEFINITIONS

- A. **Clearing:** Site clearing includes, but is not limited to, removing from the construction area, hauling to approved disposal areas, and disposing of trees, stumps, roots, brush, structures, abandoned utilities, trash, debris and all other materials found on or near the surface of the ground within construction areas. Precautionary measures that prevent damage to existing features to remain are part of the Work.
- B. **Grubbing:** Grubbing shall consist of the removal and disposal of roots, root mat, stumps, logs, and other objectionable matter which could affect the quality of the subgrade or borrow material.
- C. **Topsoil:** Topsoil is the soil, which is characterized by a significant organic content.

1.3 LOCATION OF WORK

- A. Areas to be cleared and grubbed include the existing stockpile; the areas designated for capping and soil cover placement, designated access roads, and erosion protection areas.

TECHNICAL SPECIFICATION

SECTION 02110

SITE CLEARING, GRUBBING AND TOPSOIL STRIPPING

PART 2 PRODUCTS

2.1 EQUIPMENT

- A. The Contractor shall furnish equipment of the type normally used in clearing and grubbing operations including, but not limited to, dozers, shears, skidders, loaders, root rakes, chipping equipment, and stump grinders.

PART 3 EXECUTION

3.1 EXTENT OF CLEARING AND GRUBBING

- A. The subgrade for the proposed earthfill stockpile must be cleared and grubbed in accordance with Article 3.2 herein.
- B. The existing stockpile area shall be cleared and grubbed according to this Section of the Specification except that paragraph 3.2D shall not apply.

3.2 CLEARING AND GRUBBING

- A. Materials to be cleared, grubbed and removed from the construction areas include, but are not limited to, the following: all trees, stumps, roots, brush, trash, organic matter, and debris.
- B. Vegetation within the designated areas shall be cut flush to the ground surface and disposed of in accordance with applicable laws and regulations.
- C. Stumps and roots shall be grubbed and removed to a depth not less than 2 feet below grade. Roots ½ inch diameter and greater shall be removed to a depth not less than 6 inches below grade.
- D. The Contractor shall backfill and compact the excavated root areas with fill in accordance with the requirements of Section 02221 of these Specifications.
- E. No trees outside the work area shall be harmed or damaged.
- F. The Construction Manager may permit clearing or grubbing of additional areas if necessary, provided that temporary erosion and sedimentation controls are in place in accordance with Section 02105 of these Specifications.
- G. Where tree limbs interfere with utility wires, or where trees to be felled are in proximity to utility wires, these trees shall be taken down in sections to eliminate the possibility of damage to the utility wires. The Contractor shall be responsible for damages to utilities and shall replace or repair damaged utilities at no cost to the Owner.

TECHNCIAL SPECIFICATION

SECTION 02110

SITE CLEARING, GRUBBING AND TOPSOIL STRIPPING

- H. Any Work pertaining to utility poles and guy wires shall comply with the requirements of the appropriate utility Owner.
- I. The Contractor shall be held liable for any damage to property outside of the designated Work area(s).
- J. The Contractor shall be responsible for all damages to existing structures and/or improvements resulting from the Work.
- K. The Contractor shall protect existing fencing, and any other facilities or structures to remain from damage due to construction activities. Damaged items shall be repaired or replaced at no cost to the Owner.

3.3 DISPOSAL OF DEBRIS

- A. The Contractor shall comply with applicable codes, ordinances, rules, regulations, and laws of local, municipal, State or Federal authorities having jurisdiction over this project.
- B. The existing plastic cover shall be removed and disposed of at a Subtitle D Facility.
- C. Wood may be chipped for use as mulch for temporary erosion control measures.

*****END OF SECTION*****

TECHNICAL SPECIFICATION

SECTION 02221 - EARTHWORKS

PART 1 GENERAL

1.1 SCOPE OF WORK

- A. The work shall include excavating, relocating, placing, spreading, drying, compacting, and providing geotechnical field and laboratory testing of PCB-containing material from the existing on-site stockpile to the location shown on the Contract Drawings.
- B. The work shall also include supplying (from an off-site borrow source), transporting, placing, spreading, compacting and providing geotechnical field and laboratory testing of the Structural Fill material necessary for the construction and completion of all work under the Contract.

1.2 RELATED WORK SPECIFIED ELSEWHERE

- A. Final Cover Components, Sections 02230 (Rip-Rap), 02267 (Soil Cover Material), 02310 (Geomembrane), 02320 (Geocomposite), and 02330 (Geotextile)

1.3 DEFINITIONS

- A. Embankment Fill - PCB-containing soil Material
 - 1. Existing material in the soil stockpile shall be moved, placed and compacted by heavy equipment or other methods to the approximate elevation and gradient shown on the Contract Drawings. The final elevation of the embankment may be adjusted (up or down) in the field as approved by the Construction Manager in order to accommodate the actual quantity of impacted material encountered. However, the minimum slope of 2% shall be maintained.
 - 2. The material from the stockpile consists of PCB-containing soil with some amounts of wood and concrete debris. Analytical testing results (PCB concentrations) of the material are included with the Contract Documents. The material has been stockpiled for over two years and the Contractor should anticipate that the material may be wet of the optimum moisture content as determined by ASTM D698.
- B. Structural Fill – Non PCB-containing soil
 - 1. Structural Fill material shall be imported from an off-site borrow source, placed and compacted as shown on the Contract Drawings. The material shall be soil fill consisting of sands, gravels, clay, silt or loam. The material shall not contain ashes, cinders, foundry sands, concrete, asphalt, organic debris, or

TECHNICAL SPECIFICATION

SECTION 02221 - EARTHWORKS

rocks larger than 6 inches. Additionally, the material shall not contain PCBs in excess of 1 mg/kg.

- C. Embankments
 - 1. Fills constructed above the original surface of the ground or such other elevation as specified or directed.
- D. Excavation Below Subgrade
 - 1. Excavation below existing subgrade will not be permitted, except to the lines and grades shown on the Contract Documents.
- D. Applicable Codes, Standards and Specifications
 - 1. American Society for Testing and Materials (ASTM)

1.4 SUBMITTALS

- A. The Contractor shall submit, for the Construction Manager's approval, the name and qualifications of the geotechnical professional and laboratory working for the Contractor as the Construction Quality Control Consultant. The Construction Quality Control Consultant shall be a professional engineer registered in the State of Alabama.
- B. The Contractor shall submit, at completion of the earthworks, a report signed and sealed by the Construction Quality Control Consultant certifying that the embankment has been constructed in conformance to the requirements of this Section of the Specification. This report will include the results of all geotechnical and field laboratory tests conducted as part of the CQC work by the Contractor.
- C. The name and location of the source of Structural Fill material.
- D. Analytical results (minimum of 3 tests) from PCB tests performed on the material from the proposed borrow source using USEPA Method 8082.
- E. The Contractor shall be responsible for submitting information to the Company as specified herein during the construction process. The Contractor shall submit:
 - 1. daily reports detailing the arrival of the Superintendent to the site,
 - 2. start-up and departure times,
 - 3. the progress of the work,
 - 4. the personnel and equipment present on-site,
 - 5. volumes or load counts of material placed,

TECHNICAL SPECIFICATION

SECTION 02221 - EARTHWORKS

6. results of geotechnical tests,
7. equipment down-time and malfunctions, and
8. any information additionally requested by the Contract Documents.

PART 2 PRODUCTS

2.1 STRUCTURAL FILL

- A. See Section 1.3B of this Section of the Specifications.

PART 3 EXECUTION

3.1 EXISTING STOCKPILE RELOCATION

- A. Relocation of the stockpile soils shall be made to the lines and grades existing before the soils were placed on the east banks of Snow Creek, as determined by the exposure of a continuous layer of organic material, and as directed by the Construction Manager.
- B. Whenever stockpile soil removal is carried beyond or below the lines and grades shown on the Contract Drawings, unless approved by the Construction Manager, all such excavated space shall be refilled with Structural Fill or select fill material, as determined by the Construction Manager. All refilling of unauthorized excavations shall be at the Contractor's expense. Any material from unauthorized excavation shall be stockpiled separately; and characterized and disposed of off site in accordance with all local, state and federal regulations at no additional cost to the Owner. The Construction Manager must approve the testing company, method of characterization and disposal site, if applicable.

3.2 REMOVAL OF WATER

- A. General
 1. The Contractor shall, at all times, provide and maintain proper and satisfactory means and devices for the removal of all water entering and accumulating within the work area, and shall remove all such water as fast as it may collect, in such manner as shall not interfere with the prosecution of the Work or the proper placing of fill material or other work. Removal of water, which enters the work area, shall be coordinated with the Construction Manager. All fill surfaces shall be placed and rolled to prevent ponding of water and to ensure adequate drainage.
 2. Water pumped or drained from the work area, drains or water courses encountered in the work, shall be disposed of in a suitable manner without injury to adjacent property, the work under construction or to pavement,

TECHNICAL SPECIFICATION

SECTION 02221 - EARTHWORKS

roads, drives and water courses. No water shall be discharged to sanitary sewers. Sanitary sewage shall be disposed of by an approved method in accordance with applicable laws and regulations.

3. Any damage caused by or resulting from dewatering operations shall be the sole responsibility of the Contractor.

B. Work Included

1. The maintenance of temporary ditches.
2. The furnishing and operation of pumps, well points and appliances needed to maintain thorough drainage of the work in a satisfactory manner.

3.3 SUBGRADE PREPARATION

- A. The Contractor shall not disturb the existing subgrade prior to placing PCB-containing soil material or Structural Fill, except as required for Clearing and Grubbing per Section 02110 of these Specifications. All topsoil shall remain in place.
- B. The Contractor shall not place fill material if the existing subgrade has standing water or is excessively wet.
- C. The subgrade shall be stabilized by means approved by the Construction Manager, so that compaction of the first lift of embankment fill can be achieved as per paragraph 3.4 below.

3.4 EMBANKMENT FILL PLACEMENT

A. General

1. Fill placement shall be performed to the approximate elevations shown on the Contract Drawings. The final elevations may vary dependent on the actual quantity of PCB-containing soil material obtained from the stockpile. However, the Contractor must maintain the design slopes for the embankment.
2. Fill placement for Structural Fill shall be done with suitable material which can be satisfactorily compacted during placement.
3. All PCB-containing soil shall be covered each night with plastic prior to Contractor leaving the site. This includes material in the existing stockpile and on the proposed embankment. The Contractor shall continue covering the exposed material each night until the impacted material is fully covered with the final geomembrane lining as per Section 02310 of these Specifications.
4. Any truck or piece of equipment that comes in contact with PCB-containing soil material shall be decontaminated prior to working on or with non-impacted materials or prior to leaving the site.

TECHNICAL SPECIFICATION

SECTION 02221 - EARTHWORKS

B. Unsuitable Materials

1. All stones, pieces of rock and broken pavement shall be distributed through the fill material and alternated with soil backfill in such a manner that all voids between them shall be filled with soil.
2. Wood pieces smaller than one-half ($1/2$) inch in diameter may be placed as described 3.4.B.1. Wood pieces larger than one-half ($1/2$) inch in diameter shall be removed from the fill material and disposed of per Section 02110 of these Specifications.
3. Frozen soil shall not be used for construction.

C. Compaction and Density Control (PCB-containing soil and Structural Fill)

1. The compaction shall be as specified below:
 - a) Lift thickness shall be 6 to 8 inches. Thicker or thinner lifts may be utilized, at the discretion of the Construction Manager, if satisfactory results are obtained.
 - b) The compaction specified shall be 95 percent of the maximum density as measured by Standard Proctor (ASTM D698). Structural Fill used to construct the ramp for the access road shall be compacted to 98 percent of the maximum density as measured by Standard Proctor (ASTM D698).
 - c) The compaction equipment shall be suitable for the material encountered.
2. Density and compaction testing shall be performed in accordance with the CQA Plan to verify adequate compaction of the PCB-containing soils and the Structural Fill.
 - a) The Contractor shall be responsible for quality control testing. Testing shall be performed by a specialized laboratory that has been approved by the Construction Manager.
 - b) The Contractor shall anticipate and schedule the testing as per the CQA Plan.
3. Where required, to obtain an adequate moisture content to achieve compaction, the Contractor shall add, at his expense, sufficient water during compaction to assure the specified density of the fill material. If the material is too wet to achieve the specified density, it shall be allowed to dry, assisted if necessary, before resuming compaction or filling efforts.
4. The Contractor shall be responsible for all damage or injury done to pipes, structures, property or persons due to improper placing or compacting of fill material.

TECHNICAL SPECIFICATION

SECTION 02221 - EARTHWORKS

3.5 OTHER REQUIREMENTS

A. Hauling Material on Streets

1. When it is necessary to haul material across the Waste Water Treatment Plant or over the streets or pavement, the Contractor shall provide suitable tight vehicles so as to prevent deposits on the street or pavements. In all cases where any materials are dropped from the vehicles, the Contractor shall clean up the same as often as required to keep the crosswalks, streets, and pavements clean and free from dirt, mud, stone and other hauled material.

B. Surveying

1. The Contractor shall perform an initial survey of the area where PCB-containing soil will be placed on a minimum 50-ft by 50-ft grid. The Contractor shall also survey the top of the PCB-containing soil embankment fill material on the same grid pattern to verify the quantity of PCB-containing soil placed in the embankment and to demonstrate that the minimum slope for the embankment is achieved. The surveyor shall be a Licensed Land Surveyor in the State of Alabama.

****END OF SECTION****

TECHNICAL SPECIFICATION

SECTION 02230 - RIP-RAP

PART 1 - GENERAL

1.1 SUMMARY

- A. The Work of this Section of the Specifications shall consist of the supply and installation of loose rock rip-rap at the locations shown on the Construction Drawings. Rip-rap material and its installation shall meet the requirements of the Alabama Highway Department Standard Specifications for Highway Construction.

1.2 DEFINITIONS

- A. **Rip-rap:** Stone for rip-rap shall be durable, dense, specifically selected and graded, quarried stone in accordance with Section 814.01 of the Standard Specifications of the State of Alabama Highway Department. All rip-rap shall be Class I. The material shall be resistant to the action of air and water, and in all other respects suitable for use as rip-rap. Materials not meeting these requirements shall not be used unless approved by petrographic analysis. Flat, slabby, and shaley pieces are not acceptable.

PART 2 - PRODUCTS

2.1 RIP-RAP

- A. Stone for rip-rap shall be processed in such a manner as to produce a quarry-run material including rock fines that shall meet the gradation requirements set forth below. The stone shall be durable, dense, specifically selected and graded, quarried stone in accordance with Section 814.01 of the Standard Specifications of the State of Alabama Highway Department. All rip-rap shall be Class I. The material shall be resistant to the action of air and water, and in all other respects suitable for use as rip-rap.
- B. The abrasion loss for all rip-rap shall not exceed 50 when tested in accordance with AASHTO T 96. Rocks that split into layers less than 4 inches thick, when exposed to natural weathering, shall not be used regardless of the results of the prescribed tests.
- C. Sound concrete may be substituted for stone, if it is broken into the sizes here specified.

PART 3 - EXECUTION

3.1 GENERAL

- A. Areas to be rip-rapped shall be trimmed and dressed to conform to cross-sections

TECHNICAL SPECIFICATION

SECTION 02230 - RIP-RAP

as shown on the Construction Drawings or as directed by the Construction Manager. Areas not in conformance with the cross-sections shall be brought to grade by filling with approved material and compacted.

- B. Stone for rip-rap shall be placed on prepared subgrade, in such a manner as to produce a well-graded mass of rock with minimum practicable percentages of voids and constructed within specified tolerance to lines and grades indicated on Construction Drawings or as directed by the Construction Manager.

3.2 SUBGRADE PREPARATION

- A. The subgrade surfaces on which the rip-rap is to be placed shall be filled and graded to the lines and grades shown on the Construction Drawings. When fill is required to achieve subgrade lines, it shall consist of approved materials and shall conform to the requirements of the specified class of fill.
- B. Rip-rap shall not be placed until the foundation preparation is completed and the subgrade surfaces have been inspected and approved by the Construction Manager.

3.3 PLACEMENT OF RIP-RAP

- A. Rip-rap shall be placed to full course thickness in one operation and in such a manner as to avoid disturbing subgrade. Placing rip-rap in layers or by methods likely to cause segregation of various sizes shall not be permitted. Desired distribution of various sizes of stones throughout rip-rap shall be obtained by selective loading of material at stockpile; by controlling dumping of successive loads during final placing; or by any other approved methods designed to produce specified results. Rearrangement of individual stones by mechanical equipment or by hand shall be required to the extent necessary to obtain a well graded distribution of stone sizes.

3.4 TESTING

- A. The Construction Manager may perform such tests, as he deems necessary to verify that the rip-rap material and the completed Work meet the requirements of this Specification. These tests are not intended to provide the Contractor with the information he needs to assure that the materials and workmanship meet the requirements of this Specification, and their performance shall not relieve the Contractor of the responsibility of performing his own tests for that purpose.

****END OF SECTION****

TECHNICAL SPECIFICATION

SECTION 02235 – TOE DRAIN MATERIALS

PART 1 - GENERAL

1.1 SUMMARY

- A. The Work of this Section of the Specifications comprises supply of all labor, materials and equipment and performance of all Work necessary for furnishing, placing and compacting the granular drain material required in the construction of the toe drain as shown in the Drawings.
- B. Also included is the supply of all labor, materials, and equipment and performance of all Work necessary for placing the geotextile within specified portions of the Work.

1.2 SUBMITTALS

- A. The Contractor shall submit test data and samples of the drainage material for approval prior to the delivery of such material to the work site. Unless otherwise specified, all such samples shall be obtained and delivered by the Contractor to a point designated by the Construction Manager at least thirty (30) days prior to placing the material in the toe drain.
- B. The Contractor shall submit his proposed methods for placing the drain material to the Construction Manager for approval.

PART 2 - PRODUCTS

2.1 GRANULAR DRAIN MATERIAL

- A. Drain materials shall consist of gravel or crushed rock. Gravel shall consist of clean, sound mineral particles free from any roots, topsoil or other debris. Crushed stone shall consist of broken fragments of approved strong, hard, durable, dense rock free from cracks and seams. The crushed hard rock particles to be used in the drains shall be hard, strong and dense and shall not weather, deteriorate or become cemented over the life of the project.
- B. For the purposes of this Specification, drain materials shall be classified as follows:
 - 1. AHD No. 57 Stone: The material shall be imported, clean, hard, durable, granular material or crushed rock free of organics that meets Alabama Highway Department for No. 57 coarse aggregate. The material shall be well graded within the following limits:

TECHNICAL SPECIFICATION

SECTION 02235 - TOE DRAIN MATERIALS

Sieve Size	Percent Passing by Weight
1-1/2 inch	100
1 inch	95-100
1/2 inch	25-60
No. 4	0-5

PART 3 - EXECUTION

3.1 FOUNDATION PREPARATION

- A. The foundation area for the drainage materials shall be shaped and dressed to the lines and grades shown on the Drawings. The foundation surfaces shall be maintained free of standing water during placement of materials. Foundation preparation shall conform to Section 02221 of the Technical Specifications.

3.2 PLACEMENT OF DRAINAGE MATERIALS

- A. The drain materials shall be placed to the lines and grades shown on the Drawings or as directed by the Construction Manager.
- B. The drain materials shall be spread in horizontal layers of uniform thickness by backhoe or other approved means.
- C. Traffic will not be allowed to cross over the drains at random. Equipment cross-overs shall be maintained at an elevation at least one (1) foot above the upper surface of the adjacent fill. The number of equipment cross overs and location of such shall be established and approved by the Construction Manager.

3.3 GEOCOMPOSITE DRAIN/GEOTEXTILE FABRIC

- A. The geocomposite drainage layer of the cover system shall be placed above the granular drain material as shown on the Drawings or as directed by the Construction Manager.
- B. A geotextile filter fabric shall be placed below the granular material of the toe drain and beneath the road base materials as shown on the Drawings or as directed by the Construction Manager to prevent contamination of the drainage materials.
- C. No geotextile shall be placed between the No.57 Stone and the Rip-Rap Armor.
- D. The geotextile should be placed according to manufacturer's recommendations and in such a manner to minimize the number of separate pieces of fabric

TECHNICAL SPECIFICATION

SECTION 02235 – TOE DRAIN MATERIALS

required. At all locations where fabric edges meet, the edges shall overlap by a minimum of eighteen (18) inches unless the manufacturer recommends a greater overlap. Care should be taken during placement of subsequent drain layers or earth fill layers that the fabric does not puncture, tear or become damaged in any way.

3.4 FIELD QUALITY CONTROL

- A. Final acceptance of drain materials will only be made after materials have been dumped, spread, and compacted in place. Rejection by Construction Manager may be made at source, transporting vehicle, or in place. Contractor shall cooperate with Construction Manager to ensure that only acceptable drain materials will be hauled from source to Work.
- B. Construction Manager may perform tests at random intervals to determine if drain materials meet requirements of this Section of the Specifications. Tests will be carried out at Owner's expense and test data will be made available to the Contractor.

END OF SECTION

TECHNICAL SPECIFICATION

SECTION 02267

SOIL AND TOPSOIL COVER MATERIALS

PART 1 - GENERAL

1.1 SUMMARY

- A. The Work of this Section of the Specifications comprises supply of all labor, materials, and equipment, and performance of all Work necessary for the placement of the soil and topsoil materials for construction of the cover system.

PART 2 - PRODUCTS

2.1 SOIL COVER

- A. Soil Cover material shall be placed and compacted as shown on the Contract Drawings. The material shall be soil fill consisting of silty sands, clay, silt or loam, or a combination of these. The material shall not contain ashes, cinders, foundry sands, concrete, asphalt, organic debris, or rocks larger than 6 inches. Additionally, the material shall not contain PCBs in excess of 1 mg/kg.
- B. Soil Cover shall consist of off-site borrow material meeting the following criteria:
 - 1. Maximum particle size: 6-inches
 - 2. Free of organics, foreign material, foreign objects, or other deleterious materials.
 - 3. Soil Cover material shall have a maximum hydraulic conductivity of 1×10^{-4} cm/sec.

2.2 TOPSOIL LAYER

- A. Soil material used as the Topsoil layer shall be loam, sandy loam, or silty loam as defined by the U.S. Department of Agriculture textural classification chart, and shall be suitable to support vegetative growth.
- B. The Topsoil layer shall not contain stones, lumps, roots, or similar objects larger than 2 inches in any dimension.
- C. The Topsoil layer shall have a pH between 5.8 and 7.6.
- D. Provide a material for the Topsoil layer that has a minimum organic content of 2.75 percent by weight and a maximum organic content of 5 percent by weight.
- E. Soil material used as the Topsoil layer must be capable of sustaining vegetation as specified in Section 02936 of these Specifications.

TECHNICAL SPECIFICATION

SECTION 02267

SOIL AND TOPSOIL COVER MATERIALS

- F. Composted material from the clearing and grubbing operations of Section 02110 of these Specifications may be mixed and incorporated into the Topsoil layer.

2.3 TESTING

- A. The Contractor shall, twenty-one (21) days prior to use of proposed materials, submit certification to the Construction Manager that the materials proposed comply with the Specifications for the various components of construction. This certification shall include the following tests for each type of material and each material source:

Test and Method	Soil Cover (cy)	Topsoil (cy)
Particle Size (ASTM D422)	5,000	5,000
Moisture Content (ASTM D2216 or D4643)	5,000	---
Permeability (ASTM D 5084)	10,000	---
pH (ASTM D4972)	---	5,000
Organic Content (ASTM D2974)	---	5,000
Soil Fertility (Baker or LaMotte)	---	5,000

- B. The Contractor shall be responsible for quality control testing as per the CQAP. Testing shall be performed by a specialized laboratory that has been approved by the Construction Manager.
- C. The Contractor shall submit to the Construction Manager certification of compliance along with a minimum of 100 pounds of each proposed material from each source that is proposed for use.
- D. The Contractor shall not proceed with use of the materials until the Construction Manager has favorably reviewed and approved the proposed materials.
- E. Analytical results (minimum of 3 tests) from PCB tests performed on the material from the proposed borrow source using USEPA Method 8082.
- F. If in the opinion of the Construction Manager and/or CQA Consultant, the Contractor's proposed material is unsuitable for the proposed application, the Contractor shall submit the above certification for material of another type or from another source for consideration.
- G. The Construction Manager may at any time request the collection of samples of

TECHNICAL SPECIFICATION

SECTION 02267

SOIL AND TOPSOIL COVER MATERIALS

imported materials for additional analytical and/or index property testing at the Owner's expense. Any imported materials from off-Site borrow sources found to not be in accordance with the Specifications, or found to be contaminated, shall immediately be removed and replaced with suitable materials at the Contractor's expense with no time extensions in the Construction Schedule granted.

PART 3 - EXECUTION

3.1 SOIL COVER PLACEMENT

- A. Soil Cover materials shall not be placed until the geosynthetic components have been inspected in-place and approved by the Construction Manager.
- B. The Soil Cover shall be placed (final lift) and compacted to achieve a homogeneous layer with a permeability no less than 1.0×10^{-4} cm/sec.
- C. Employ a placement method that does not disturb or damage other work.
- D. Make gradual grade changes. Blend slope into level areas.
- E. Placement of the Soil Cover on the geosynthetics shall be with low ground pressure equipment (5.5 psi or less contact pressure) with a minimum of 9 inches of compacted soil material between the equipment and the geosynthetics.
- F. The Soil Cover on the geosynthetics shall be placed on the flat portion of the cover, first. No equipment shall be allowed to place soil on the slopes until the 18-inches of Soil Cover is complete on the entire flat (2%) portion of the lined embankment.

3.2 PLACEMENT OF TOPSOIL LAYER

- A. No Topsoil layer material shall be placed until the Soil Cover placement is complete and approved by the Construction Manager.
- B. The Topsoil layer shall be placed in a single, 6-inch thick lift.
- C. The Contractor shall take care to ensure that underlying soil remains intact and does not become mixed with the Topsoil layer during installation.

END OF SECTION

TECHNICAL SPECIFICATION

SECTION 02310-HDPE GEOMEMBRANE

PART 1 GENERAL

1.1 SCOPE OF WORK

- A. The Work of this Section of the Specifications includes supply of all labor, materials, and equipment, and performance of all Work necessary for the manufacturing, storage, delivery, installation, and testing of the geomembrane portions of the cover system, including installation as herein specified and as shown on the Construction Drawings.

1.2 DEFINITIONS

- A. "Regrind" and "Trim": Finished geomembrane sheet material that was cut from the edges or ends of rolls during the manufacturing process, or is off-specification material due strictly to thickness or surgical blemishes.
- B. "Reclaimed" or "Recycled": Materials which have been shipped from the manufacturing facility, rejected, and returned for reuse, or material which has actually seen some type of field service and has been returned to be remanufactured into new geomembrane.
- C. "Crazing": Hairline cracks that may form when HDPE geomembranes are folded creased or pinched.

1.3 QUALIFICATIONS

- A. Manufacturer
 - 1. Manufacturer shall have produced the proposed geomembrane sheets for at least ten (10) completed projects having a total minimum area of two million (2,000,000) square feet.
- B. Installer
 - 1. The Installer is responsible for field handling, deploying, seaming, anchoring, and field Quality Control (QC) testing of the geomembrane. The Installer shall have installed the proposed geomembrane material for at least ten (10) completed projects having a total minimum area of two million (2,000,000) square feet. At least one seamer shall have experience seaming a minimum of one million (1,000,000) square feet of the proposed geomembrane using the same type of seaming equipment and geomembrane thickness specified for this project.

TECHNICAL SPECIFICATION
SECTION 02310-HDPE GEOMEMBRANE

- C. Construction Quality Control (CQC) Inspector
 - 1. The Construction Quality Control (CQC) Inspector is a person hired by the Contractor, who is responsible for monitoring and documenting activities, related to the CQC of the geomembrane from manufacturing through installation. The CQC Inspector shall have provided CQC inspection during installation of the proposed geomembrane material for at least five (5) completed projects having a total minimum area of one million (1,000,000) square feet.

- D. Quality Assurance
 - 1. Quality Assurance shall be provided by the CQA Consultant and paid for by the Owner. Quality assurance testing and documentation shall be performed in accordance with the CQA Plan.

- E. QC laboratory
 - 1. The QC laboratory shall be contracted by the Owner. The QC laboratory shall be accredited via the Geosynthetic Accreditation Institute's Laboratory Accreditation Program (GAI-LAP) for the tests the QC laboratory shall be required to perform.

1.4 SUBMITTALS

- A. Raw Materials (Resin): Manufacturer's certified raw material test reports and a copy of the CQC certificates, a minimum of seven (7) days prior to shipment of geomembrane to the site.
- B. Sheet Material: Manufacturer's certified sheet material test reports and a copy of the CQC certificates, a minimum of seven (7) days prior to shipment of geomembrane to the site.
- C. Warrantee: Manufacturer's 10-year product warrantee, a minimum of seven (7) days prior to shipment of geomembrane to the site.
- D. Construction Drawings:
 - 1. Layout and Detail Construction Drawings: Geomembrane panel layout and penetration detail Construction Drawings, a minimum of seven (7) days prior to geomembrane placement.

TECHNICAL SPECIFICATION

SECTION 02310-HDPE GEOMEMBRANE

- E. Quality Control Procedures:
1. Tests, Inspections, and Verifications
 2. Manufacturer's and fabricator's CQC manuals, a minimum of seven (7) days prior to geomembrane shipment.
 3. Field Seaming
 4. Installer's CQC manual, a minimum of seven (7) days prior to geomembrane placement.
- F. Statements
1. Manufacturer's, and fabricators qualification statements, including resumes of key personnel involved in the project, a minimum of seven (7) days prior to geomembrane shipment.
 2. Installer's and CQC Inspector's qualification statements including resumes of key personnel involved in the project, a minimum of seven (7) days prior to geomembrane placement.
- G. Reports:
1. Surface Preparation
 - a) Certification from the CQC Inspector and Installer of the acceptability of the surface on which the geomembrane is to be placed, immediately prior to geomembrane placement.
 2. Thickness Measurement.
 - a) Test results of panel thickness measurement, certified by CQC Inspector.
 3. Non-Destructive Field Seam Continuity Testing.
 - a) CQC Inspector's certified test results on all field seams.
 4. Destructive Field Seam Testing.
 - a) Installer's test results on all destructively tested field seams.
 5. Destructive Seam Test Repairs.
 - a) CQC Inspector's certified test results on all repaired seams.
- H. Samples:
1. Geomembrane CQC samples.

TECHNICAL SPECIFICATION

SECTION 02310-HDPE GEOMEMBRANE

1.5 DELIVERY, STORAGE AND HANDLING

A. Delivery

1. The Construction Manager or the CQA Consultant shall be present during delivery and unloading of the geomembrane. Each geomembrane roll shall be labeled with the manufacturer's name, product identification number, roll number, and roll dimensions.

B. Storage

1. Temporary storage at the project site shall be on a level surface, free of sharp objects where water cannot accumulate. The geomembrane shall be protected from puncture, abrasion, excessive heat or cold, material degradation, or other damaging circumstances. Storage shall not result in crushing the core of roll goods or flattening of the rolls. Rolls shall not be stored more than two high. Palleted materials shall be stored on level surfaces and shall not be stacked on top of one another. Ultraviolet sensitive materials shall be covered with a sacrificial opaque and waterproof covering or placed in a temporary shelter. Damaged geomembrane shall be removed from the site and replaced with geomembrane that meets the specified requirements.

C. Handling

1. Rolls shall not be dragged, lifted by one end, or dropped. A pipe or solid bar, of sufficient strength to support the full weight of a roll without significant bending, shall be used for all handling activities. The diameter of the pipe or solid bar shall be small enough to be easily inserted through the core of the roll. Chains shall be used to link the ends of the pipe or bar to the ends of a spreader bar. The spreader bar shall be wide enough to prevent the chains from rubbing against the ends of the roll. Alternatively, a stinger bar protruding from the end of a forklift or other equipment may be used. The stinger bar shall be at least three-fourths (3/4) the length of the core and must be capable of supporting the full weight of the roll without significant bending. If recommended by the manufacturer, a sling handling method utilizing appropriate loading straps may be used.

1.6 WEATHER LIMITATIONS

- A. Geomembrane shall not be deployed or field-seamed in the presence of excess moisture (i.e., rain, fog, dew), in areas of ponded water, or in the presence of excess wind. Unless authorized by the Construction Manager or the CQA Consultant, no placement or seaming shall be attempted at ambient temperatures below zero (0) degrees C or above forty (40) degrees C. Ambient temperature shall be measured at a height no greater than six (6) inches above the ground or geomembrane surface. If seaming is allowed below zero (0) degrees C, the procedures outlined in GRI Test

TECHNICAL SPECIFICATION

SECTION 02310-HDPE GEOMEMBRANE

Meth GM-9 shall be followed. In marginal conditions, seaming shall cease unless destructive field seam tests, conducted by the QC laboratory, confirm that seam properties meet the requirements listed in Table 2. Tests shall be conducted in accordance with Section 3.5B Destructive Field Seam Testing.

1.7 EQUIPMENT

- A. Equipment used in performance of the work shall be in accordance with the geomembrane manufacturer's recommendations and shall be maintained in satisfactory working condition.

PART 2 PRODUCTS

2.1 GENERAL

- A. The cover geomembrane shall be a forty-(40) mil thick high-density polyethylene (HDPE) flexible membrane smooth liner.

2.2 RAW MATERIALS (RESIN)

- A. Resin used in manufacturing geomembrane sheets shall be made of virgin uncontaminated ingredients. No more than ten (10) percent regrind, reworked, or trim material in the form of chips or edge strips shall be used to manufacture the geomembrane sheets. All regrind, reworked, or trim materials shall be from the same manufacturer and exactly the same formulation as the geomembrane sheet being produced. No post consumer materials or water-soluble ingredients shall be used to produce the geomembrane. For geomembranes with plasticizers, only primary plasticizers that are resistant to migration shall be used. The Contractor shall submit a copy of the test reports and CQC certificates for materials used in the manufacturing of the geomembrane shipped to the site.

2.3 SHEET MATERIALS

- A. Geomembrane sheets shall be unreinforced and manufactured as wide as possible to minimize field seams. Geomembrane sheets shall be uniform in color, thickness, and surface texture. The sheets shall be free of, and resistant to, fungal or bacterial attack and free of cuts, abrasions, holes, blisters, contaminants, and other imperfections. Geomembrane sheets and seams shall conform to the requirements listed in Tables 1 and 2 for Manufacturing Quality Control (MQC) and Construction Quality Control (CQC).

TECHNICAL SPECIFICATION
SECTION 02310-HDPE GEOMEMBRANE

TABLE 1
SMOOTH 40-MIL HDPE GEOMEMBRANE PROPERTIES

PROPERTY	TEST VALUE	MQC* TESTING FREQUENCY (MIN.)	TEST METHOD
Thickness (min average)	40 mil	per roll	ASTM D 5199
Lowest individual of 10 values	-10 percent	per roll	ASTM D 5199
Density (min)	0.940 g/cc	per 200,000 lbs	ASTM D 1505
Tensile Properties (1) (min average) -yield stress -break stress -yield elongation -break elongation	84 lbs/in 152 lbs/in 12 percent 700 percent	per 20,000 lbs	ASTM D 638 Type IV
Tear Resistance (min average)	28 lbs	per 45,000 lbs	ASTM D 1004
Puncture Resistance (min average)	72 lbs	per 45,000 lbs	ASTM D 4833
Stress Crack Resistance (2) (@30% of min. yield stress)	200 hr	per 200,000 lbs	ASTM D 5397 (Appendix)
Carbon Black Content percent	2.0-3.0 percent	per 20,000 lbs	ASTM D 1603 (3)
Carbon Black Dispersion	Note (4)	per 45,000 lbs	ASTM D 5596
Oxidative Induction Time (OIT)(min average) (5) -Std OIT or -High Pressure OIT	100 min 400 min	per 200,000 lbs	ASTM D 3895 ASTM D 5885
Oven Aging at 85 deg C (min average)(5), (6) -Std OIT or -High Pressure OIT	55 percent at 90 days 80 percent at 90 days	per year and change in formulation	ASTM D 5721 ASTM D 3895 ASTM D 5885
UV Resistance (min average) (7) -High Pres OIT	60 percent	per year and change in formulation	GRI Test Meth GM-11 ASTM D 5885

*MQC = Manufacturing Quality Control

Note (1): Minimum average machine direction and minimum average cross machine direction values shall be based on five (5) test specimens each direction. Yield elongation is calculated using a gauge length of 1.3 inches. Break elongation is calculated using a gauge length of two (2) inches.

Note (2): The yield stress used to calculate the applied load for test method ASTM D 5397 (Appendix), shall be the manufacturer's mean value.

TECHNICAL SPECIFICATION
SECTION 02310-HDPE GEOMEMBRANE

Note (3): Other methods such as ASTM D 4218 or microwaverage methods are acceptable if an appropriate correlation to ASTM D 1603 can be established.

Note (4): Carbon black dispersion for ten (10) different views:
 - minimum 8 of 10 in Categories 1 or 2
 - all 10 in Categories 1, 2, or 3

Note (5): The manufacturer has the option to select either one of the OIT methods to evaluate the antioxidant content.

Note (6): Evaluate samples at thirty (30) and sixty (60) days and compare with the ninety (90) day response.

Note (7): The condition of the test shall be a twenty (20) hour UV cycle at twenty (20) degrees C followed by a four (4) hour condensation cycle at sixty (60) degrees C.

TABLE 2
40-MIL HDPE SEAM PROPERTIES

PROPERTY	TEST VALUE	TEST METHOD
Seam Shear Strength (min) (1)	80 lbs/in	ASTM D6392
Seam Peel Strength (min) (1) (2)	48 lbs/in and FTB (1)	ASTM D6392

Note (1): Seam tests for peel and shear must fail in the Film Tear Bond mode. This is a failure in the ductile mode of one of the bonded sheets by tearing or breaking prior to complete separation of the bonded area.

Note (2): Where applicable, both tracks of a double hot wedge seam shall be tested for peel adhesion.

2.4 CONSTRUCTION QUALITY CONTROL

A. Manufacturing, Sampling, and Testing

1. Raw materials shall be tested in accordance with the approved MQC manual. Any raw material which fails to meet the geomembrane manufacturer's specified physical properties shall not be used in manufacturing the sheet. Seaming rods and pellets shall be manufactured of materials which are essentially identical to that used in the geomembrane sheet. Seaming rods

TECHNICAL SPECIFICATION

SECTION 02310-HDPE GEOMEMBRANE

and pellets shall be tested for density, melt index, and carbon black content in accordance with the approved MQC manual. Seaming rods and pellets which fail to meet the corresponding property values required for the sheet material, shall not be used for seaming.

2. Geomembrane sheets shall be tested in accordance with the approved MQC manual. As a minimum, MQC testing shall be conducted at the frequencies shown in Table 1. Sheets not meeting the minimum requirements specified shall not be sent to the site.

PART 3 EXECUTION

3.1 PREPARATION

- A. Surface Preparation shall be performed in accordance with Section 02221, particles larger than one half ($\frac{1}{2}$) inch in diameter and any other material which could damage the geomembrane shall be removed from the surface to be covered with the geomembrane. Construction equipment tire or track deformations beneath the geomembrane shall not be greater than one-half ($\frac{1}{2}$) inch in depth. Each day during placement of geomembrane, the Construction Manager and Installer shall inspect the surface on which geomembrane is to be placed and certify in writing that the surface is acceptable. Repairs to the subgrade shall be performed at no additional cost to the Owner.

3.2 GEOMEMBRANE DEPLOYMENT

- A. The procedures and equipment used shall not elongate, wrinkle, scratch, or otherwise damage the geomembrane or underlying subgrade. Geomembrane damaged during installation shall be replaced or repaired, at the Construction Manager's discretion. Only geomembrane panels that can be anchored and seamed together the same day shall be deployed. Adequate ballast (i.e., sand bags) shall be placed on the geomembrane, without damaging the geomembrane, to prevent uplift by wind. No equipment shall be operated on the top surface of the geomembrane without permission from the Construction Manager.
- B. Seams shall be oriented parallel to the line of maximum slope. Where seams can only be oriented across the slope, the upper panel shall be lapped over the lower panel.
- C. Placement of geocomposite drainage net and protective cover material on the geomembrane shall not proceed at an ambient temperature below zero (0) °C or above forty (40) °C.
- D. The methods used to deploy and backfill over the geomembrane shall minimize wrinkles and tensile stresses in the geomembrane. The geomembrane shall have adequate slack to prevent the creation of tensile stress. The wrinkle height to width

TECHNICAL SPECIFICATION

SECTION 02310-HDPE GEOMEMBRANE

ratio for installed geomembrane shall not exceed zero point five (0.5). In addition, geomembrane wrinkles shall not exceed six (6) inches in height. Wrinkles that do not meet the above criteria shall be cut out and repaired in accordance with the Installer's approved CQC manual.

- E. A minimum of five (5) thickness measurements shall be taken along the edge of each panel width and at least two thickness measurements shall be taken along each panel length. The thickness shall be measured in accordance with ASTM D 5994. If thickness readings fall below the values specified in Table 1, the entire panel shall be rejected and replaced.

3.3 FIELD SEAMING

A. Trial Seams

- 1. Trial seams shall be made under field conditions on strips of excess geomembrane. Trial seams shall be made each day prior to production seaming, whenever there is a change in seaming personnel or seaming equipment and at least once every four hours, by each seamer and each piece of seaming equipment used that day. One sample shall be obtained from each trial seam. This sample shall be at least three (3) feet long by one and one-half (1.5) feet wide with the seam centered lengthwise. Ten random specimens one (1) inch wide shall be cut from the sample. Five seam specimens shall be field tested for shear strength and five (5) seam specimens shall be field tested for peel adhesion using an approved quantitative tensiometer. Jaw separation speed shall be in accordance with the Installer's approved CQC manual. Where necessary, accelerated curing of trial seams made by chemical methods shall be conducted in accordance with GRI Test Meth GM-7. To be acceptable, four (4) out of five (5) replicate test specimens shall meet seam strength requirements specified in Table 2. If the field tests fail to meet these requirements, the entire operation shall be repeated. If the additional trial seam fails, the seaming apparatus or seamer shall not be used until the deficiencies are corrected by the Installer and two (2) consecutive successful trial seams are achieved.

B. Field Seams

- 1. Panels shall be seamed in accordance with the geomembrane manufacturer's recommendations. In corners and odd-shaped geometric locations, the number of field seams shall be minimized. Seaming shall extend to the outside edge of panels. Wet surfaces shall be thoroughly dried and soft subgrades compacted and approved prior to seaming. The seam area shall be

TECHNICAL SPECIFICATION

SECTION 02310-HDPE GEOMEMBRANE

free of moisture, dust, dirt, and foreign material at the time of seaming. Fish mouths in seams shall be repaired.

2. The geomembrane shall be seamed by thermal fusion methods. Extrusion welding shall only be used for patching and seaming in locations where thermal fusion methods are not feasible. Seam overlaps that are to be attached using extrusion welds shall be ground prior to welding. Grinding marks shall be oriented perpendicular to the seam direction and no marks shall extend beyond the extrudate after placement. Extrusion welding shall begin within ten (10) minutes after grinding. Where extrusion welds are temporarily terminated long enough to cool, they shall be ground prior to applying new extrudate over the existing seam. The total depth of the grinding marks shall be no greater than ten (10) percent of the sheet thickness.

3.4 CONSTRUCTION QUALITY ASSURANCE (CQA) SAMPLES

- A. CQA samples, three (3) feet in length, for the entire width of a roll, shall be obtained as determined by the Construction Manager or the CQA Consultant of material delivered to the site. Samples shall not be obtained from the first three (3) feet of the roll. The samples shall be identified by manufacturer's name, product identification, lot and roll number. The date, a unique sample number, and the machine direction shall also be noted. Testing of the CQA samples shall be paid for by the Owner.
- B. The CQA Consultant shall provide the CQA samples to the QC laboratory to determine density, specific gravity, thickness, tensile strength at break, elongation at break, and tear resistance in accordance with the methods specified in Table 1. Samples not meeting the specified requirements shall result in the rejection of applicable rolls. As a minimum, rolls produced immediately prior to and immediately after the failed roll shall be tested for the same failed parameter. Testing shall continue until a minimum of three successive rolls on both sides of the original failing roll pass the failed parameter. Additional testing required for failed tests shall be paid for by the Contractor.

3.5 CONSTRUCTION QUALITY CONTROL TESTS

- A. Non-Destructive Field Seam Continuity Testing
 1. Field seams shall be non-destructively tested by the Contractor for continuity over their full length in accordance with the Installer's approved CQC manual. Seam testing shall be performed as the seaming work progresses, not at the completion of field seaming. Any seams which fail shall be

TECHNICAL SPECIFICATION

SECTION 02310-HDPE GEOMEMBRANE

documented and repaired in accordance with the Installer's approved CQC manual.

B. Destructive Field Seam Testing

1. A minimum of one destructive test sample per five hundred (500) linear feet of field seam shall be obtained at locations approved by the CQA Consultant. Sample locations shall not be identified prior to seaming. Samples shall be a minimum of one (1) foot wide by three (3) feet long with the seam centered lengthwise. Each sample shall be cut into three (3) equal pieces, with one piece retained by the Installer and the remaining pieces given to the CQA Consultant for testing and/or permanent record. Each sample shall be numbered and cross referenced to a field log which identifies: 1) panel number; 2) seam number; 3) date and time cut; 4) ambient temperature within six (6) inches above the geomembrane; 5) seaming unit designation; 6) name of seamer; and 7) seaming apparatus temperature and pressures (where applicable). Ten one (1) inch wide replicate specimens shall be cut from the Installer's sample. Five (5) specimens shall be tested for shear strength and five (5) for peel adhesion using an approved field quantitative tensiometer. Jaw separation speed shall be in accordance with the approved CQC manual. To be acceptable, four (4) out of five (5) replicate test specimens shall meet the specified seam strength requirements in Table 2. If the field tests pass, five (5) specimens shall be tested at the QC laboratory for shear strength and five (5) for peel adhesion in accordance with the QC laboratory's approved procedures. To be acceptable, four (4) out of five (5) replicate test specimens shall meet the specified seam strength requirements in Table 2. If the field or laboratory tests fail, the seam shall be repaired in accordance with paragraph 3.6A, Destructive Seam Test Repairs. Holes for destructive seam samples shall be repaired the same day they are cut.

3.6 DEFECTS AND REPAIRS

A. Destructive Seam Test Repairs

1. Seams that fail destructive seam testing may be overlaid with a strip of new material and seamed (cap stripped). Alternatively, the seaming path shall be retraced to an intermediate location a minimum of ten (10) feet on each side of the failed seam location. At each location a one (1) foot by three (3) foot minimum size seam sample shall be taken for two (2) additional shear strength and two (2) additional peel adhesion tests using an approved quantitative field tensiometer. If these tests pass, then the remaining seam sample portion shall be sent to the QC laboratory for five (5) shear strength and five (5) peel adhesion tests in accordance with the QC laboratory's approved procedures. To be acceptable, four (4) out of five (5) replicate test

TECHNICAL SPECIFICATION

SECTION 02310-HDPE GEOMEMBRANE

specimens must meet specified seam strength requirements. If these laboratory tests pass, then the seam shall be cap stripped between that location and the original failed location. If field or laboratory tests fail, the process shall be repeated. After cap stripping, the entire cap stripped seam shall be non-destructively tested in accordance with Section 3.5A, Non-Destructive Field Seam Continuity Testing.

B. Patches

1. Tears, holes, blisters, and other defects shall be repaired with patches. Patches shall have rounded corners, be made of the same geomembrane, and extend a minimum of six (6) inches beyond the edge of defects. Repairs shall be non-destructively tested. The CQA Consultant may also elect to perform destructive seam tests on suspect areas.

3.7 VISUAL INSPECTION AND EVALUATION

- A. Immediately prior to covering, the geomembrane, seams, and non-seam areas shall be visually inspected by the CQA Consultant for defects, holes, or damage due to weather conditions or construction activities. At the Construction Manager's discretion, the surface of the geomembrane shall be brushed, blown, or washed by the Installer if the amount of dust, mud, or foreign material inhibits inspection or functioning of the overlying material. Each suspect location shall be non-destructively tested in accordance with Section 3.5A, Non-Destructive Field Seam Continuity Testing. Each location that fails non-destructive testing shall be repaired in accordance with Section 3.6B, Patches, and non-destructively retested.

3.8 PENETRATIONS

- A. Geomembrane penetration details shall be as shown on the Construction Drawings. Factory fabricated boots shall be used wherever possible. Field seams for penetrations shall be non-destructively tested in accordance with the Installer's approved CQC manual. Seams that fail non-destructive testing shall be repaired in accordance with the Installer's approved CQC manual and non-destructively tested prior to acceptance.

3.9 PROTECTION AND BACKFILLING

- A. The deployed and seamed geomembrane shall be covered with the geocomposite drainage layer and protective cover material within five (5) calendar days of acceptance. Wrinkles in the geomembrane shall be prevented from folding over during placement of drainage materials. Drainage material shall not be dropped onto

TECHNICAL SPECIFICATION

SECTION 02310-HDPE GEOMEMBRANE

the geomembrane or overlying geosynthetics from a height greater than three (3) feet. The soil shall be pushed out over the geomembrane or overlying geosynthetics in an upward tumbling motion. Soil shall be placed from the bottom of the slope upward. The initial loose soil lift thickness shall be one (1) foot. Equipment with ground pressures less than six (6) psi shall be used to place the first lift over the geocomposite drainage layer. A minimum of three (3) feet of soil shall be maintained between full-scale construction equipment tires/tracks and the geomembrane or overlying geosynthetics during the covering process. Equipment placing protective cover material shall not stop abruptly, make sharp turns, spin their wheels, or travel at speeds exceeding five (5) mph.

3.10 AS-BUILT CONSTRUCTION DRAWINGS

- A. Final as-built Construction Drawings of the geomembrane installation shall be prepared by the Contractor. These Construction Drawings shall include panel numbers, seam numbers, location of repairs, destructive seam samples, and penetrations.

****END OF SECTION****

TECHNICAL SPECIFICATION

SECTION 02320-GEOCOMPOSITE DRAINAGE NET

PART 1 GENERAL

1.1 SCOPE OF WORK

- A. The Work of this Section of the Specifications comprises supply of all labor, materials, and equipment, and performance of all Work necessary for the manufacturing, storage, delivery, installation, and testing of the geocomposite drainage net portion of the lining system, including installation as herein specified and as shown on the Construction Drawings. The geocomposite shall consist of a layer of geotextile thermally bonded to one side of a geonet. Requirements for geotextiles are contained in Section 02330, Geotextiles, of these specifications. Requirements for geonets and the finished geocomposites are contained in this section.

1.2 QUALIFICATIONS

- A. Manufacturer
 - 1. Manufacturer shall have produced the proposed geocomposite sheets for at least ten (10) completed projects having a total minimum area of two million (2,000,000) square feet.
- B. Installer
 - 1. The Installer is responsible for field handling, deploying, joining, anchoring, and field Quality Control (QC) testing of the geocomposite. The Installer shall have installed the proposed geocomposite material for at least ten (10) completed projects having a total minimum area of two million (2,000,000) square feet.
- C. Construction Quality Control (CQC) Inspector
 - 1. The Construction Quality Control (CQC) Inspector is the person hired by the Contractor, who is responsible for monitoring and documenting activities, related to the CQC of the geocomposite from manufacturing through installation. The CQC Inspector shall have provided CQC inspection during installation of the proposed geocomposite material for at least five (5) completed projects having a total minimum area of one million (1,000,000) square feet.
- D. Quality Assurance
 - 1. Quality Assurance will be provided by the CQA Consultant and paid for by the Owner. Quality assurance testing and documentation will be performed in accordance with the CQA Plan.

TECHNICAL SPECIFICATION

SECTION 02320-GEOCOMPOSITE DRAINAGE NET

1.3 SUBMITTALS

- A. Raw Materials (Resin): Manufacturer's certified raw material test reports and a copy of the CQC certificates, a minimum of seven (7) days prior to shipment of geocomposite to the site.
- B. Sheet Material: Manufacturer's certified sheet material test reports and a copy of the CQC certificates, a minimum of seven (7) days prior to shipment of geocomposite to the site.
- C. Warrantee: Manufacturer's 10-year product warrantee, a minimum of seven (7) days prior to shipment of geomembrane to the site.
- D. Submit documentation and test results, if available, of the chemical resistance of the geonet to be provided for the project with "typical" municipal solid waste leachate or other specific constituents.
- E. Quality Control Procedures:
 - 1. Tests, Inspections, and Verifications
 - 2. Manufacturer's and fabricator's CQC manuals, a minimum of seven (7) days prior to geomembrane shipment.
 - 3. Field Joining
 - 4. Installer's CQC manual, a minimum of seven (7) days prior to geocomposite placement.
- F. Statements
 - 1. Manufacturer's, and fabricators qualification statements, including resumes of key personnel involved in the project, a minimum of seven (7) days prior to geocomposite shipment.
 - 2. Installer's and CQC Inspector's qualification statements including resumes of key personnel involved in the project, a minimum of seven (7) days prior to geocomposite placement.
- G. Samples:
 - 1. Geocomposite CQC samples.

1.4 DELIVERY, STORAGE AND HANDLING

- A. Delivery
 - 1. The Construction Manager or the CQA Consultant shall be present during delivery and unloading of the geocomposite. Each geocomposite roll shall be labeled with the manufacturer's name, product identification number, roll number, and roll dimensions.

TECHNICAL SPECIFICATION

SECTION 02320-GEOCOMPOSITE DRAINAGE NET

B. Storage

1. Temporary storage at the project site shall be on a level surface, free of sharp objects where water cannot accumulate. The geocomposite shall be protected from puncture, abrasion, excessive heat or cold, material degradation, or other damaging circumstances. Storage shall not result in crushing the core of roll goods or flattening of the rolls. Rolls shall not be stored more than two high. Ultraviolet sensitive materials shall be covered with a sacrificial opaque and waterproof covering or placed in a temporary shelter. Damaged geocomposite shall be removed from the site and replaced with geocomposite that meets the specified requirements.

C. Handling

1. Rolls shall not be dragged, lifted by one end, or dropped. A pipe or solid bar, of sufficient strength to support the full weight of a roll without significant bending, shall be used for all handling activities. The diameter of the pipe or solid bar shall be small enough to be easily inserted through the core of the roll. Chains shall be used to link the ends of the pipe or bar to the ends of a spreader bar. The spreader bar shall be wide enough to prevent the chains from rubbing against the ends of the roll. Alternatively, a stinger bar protruding from the end of a forklift or other equipment may be used. The stinger bar shall be at least three-fourths (3/4) the length of the core and also must be capable of supporting the full weight of the roll without significant bending. If recommended by the manufacturer, a sling handling method utilizing appropriate loading straps may be used.

1.5 WEATHER LIMITATIONS

- A. The Contractor shall not attempt the deployment of geocomposite during precipitation events or on slopes with frost or precipitation accumulation without prior authorization of the Construction Manager and implementation of proper safety precautions.

1.6 EQUIPMENT

- A. Equipment used in performance of the work shall be in accordance with the geocomposite manufacturer's recommendations and shall be maintained in satisfactory working condition.

PART 2 PRODUCTS

2.1 GENERAL

- A. The geocomposite drainage net shall consist of a layer of geotextile thermally bonded to one side of a high density polyethylene (HDPE) geonet.

TECHNICAL SPECIFICATION

SECTION 02320-GEOCOMPOSITE DRAINAGE NET

2.2 GEONET RAW MATERIALS (RESIN)

- A. The geonet shall be manufactured using new, first-quality, polyethylene resin specifically produced for use in the manufacture of the type of geonet to be supplied for this project. "Reclaimed" or "recycled" polymer shall not be added to the resin. However, "regrind" or "trim" may be used provided that this material is free of any contamination, and that the amount of "regrind" or "trim" does not exceed two percent (2%) by weight for solid (unfoamed) geonet.
- B. The resin used to manufacture the geonet material supplied to the project shall, at a minimum, meet the specifications detailed in Table 1. Geonet material manufactured from resin which does not meet these Specifications shall be rejected and removed from the Site and replaced by the Contractor at no expense to the Owner.

2.3 SHEET MATERIALS (GEONET)

- A. The geonet product shall be manufactured as a high density polyethylene (HDPE) (after the addition of carbon black) and stabilized to resist exposure to ultraviolet light. The geonet materials shall have consistent appearance and properties and shall be free of foreign matter. The geonet provided shall, at a minimum, meet the properties and test methods detailed in Table 2 and the minimum property values submitted by the Geonet Manufacturer in accordance with this Section of the Specifications.
- B. The Geonet Manufacturer shall provide, in writing, a statement that the properties of the geonet material being supplied to the project, at a minimum, meet the values specified in Table 2. Geonet material which does not meet these Specifications shall be rejected and removed from the Site and replaced by the Contractor at no expense to the Owner.

2.4 SHEET MATERIALS (GEOCOMPOSITE)

- A. The geocomposite shall consist of geotextile thermally bonded to one side of the HDPE geonet. Geocomposite properties shall meet or exceed the values specified in Table 3.

**TABLE 1
GEONET RESIN PROPERTIES**

PROPERTY	QUALIFIER	ASTM TEST METHOD	UNITS	VALUE
Specific Gravity	Minimum	D1505	g/cm ³	0.93 (2)
Melt Flow Rate	Maximum	D1238 Condition 190/2.16	(g/10 minutes)	1.0
Carbon Black Content (1)	Range	D1603	percent	2-3

TECHNICAL SPECIFICATION

SECTION 02320-GEOCOMPOSITE DRAINAGE NET

NOTE:

- 1) This Carbon Black Content property only applies to resin which is supplied to the Geonet Manufacturer precompounded with carbon black.
- 2) Raw resin density without the addition of carbon black. If the resin is precompounded with carbon black, the density shall be a minimum of 0.94 g/cm³.

**TABLE 2
GEONET ROLL MATERIAL PROPERTIES**

PROPERTY	QUALIFIER	ASTM TEST METHOD	UNITS	VALUE
Thickness (at strand intersection)	nominal	D1777	inches	0.265
Mass per Unit Area	minimum	D3776	lb/ft ²	0.162
Carbon Black Content (1)	Range	D1603	percent	1.5 - 3
Melt Flow Rate (2)	maximum	D1238	g/10 min	1.1
Tensile Strength	minimum	D1682	lb/in.	30
Transmissivity (3) (At normal stress 500 psf)	minimum	D4716	m ² /sec	0.01

NOTES:

1. The Geonet Manufacturer is not required to test the Carbon Black Content of the geonet rolls if the resin was supplied precompounded with carbon black and it was included as a resin property test as detailed in Table 1.
2. Melt Flow Rate measured using Condition 190/2.16.
3. Transmissivity measured using water at 20 deg. C and hydraulic gradient of $\frac{1}{3}$, between two smooth plates.
4. Geonet provided shall not include products manufactured using a foaming or entrainment process.

**TABLE 3
GEOCOMPOSITE ROLL MATERIAL PROPERTIES**

PROPERTY	QUALIFIER	ASTM TEST METHOD	UNITS	VALUE
Adhesion	Minimum	F904, modified	lb/in	1.5
Transmissivity (1) (At normal stress 500 psf)	minimum	D4716	m ² /sec	5 x 10 ⁻³

NOTES:

1. Transmissivity measured using water at 20 deg. C and hydraulic gradient of $\frac{1}{3}$, between two smooth

TECHNICAL SPECIFICATION

SECTION 02320-GEOCOMPOSITE DRAINAGE NET

plates.

2.5 CONSTRUCTION QUALITY CONTROL

A. Manufacturing, Sampling, and Testing

1. Raw materials shall be tested in accordance with the approved MQC manual. Any raw material which fails to meet the geocomposite manufacturer's specified physical properties shall not be used in manufacturing the sheet.
2. Geotextile, geonet, and geocomposite sheets shall be tested in accordance with the approved MQC manual. As a minimum, MQC testing shall be conducted at the frequencies shown below. Sheets not meeting the minimum requirements specified in Tables 2 and 3 shall not be sent to the site.

Property	Frequency
Specific Gravity	1 per 20,000 ft ²
Carbon Black Content	1 per 40,000 ft ²
Thickness	1 per 20,000 ft ²
Transmissivity	1 per 200,000 ft ²
Tensile Strength	1 per 20,000 ft ²

PART 3 EXECUTION

3.1 HANDLING AND PLACEMENT

- A. The Contractor shall handle all geocomposite in such a manner to ensure that these materials are not damaged.
- B. Clean geomembrane surface prior to placing geocomposite.
- C. The geocomposite shall be placed with the geonet in direct contact with the geomembrane.
- D. In the presence of wind, all exposed geocomposites shall be weighted with sandbags or equivalent. Sandbags shall be installed during geocomposite placement and shall remain until replaced with soil cover material.
- E. Geocomposite shall not be welded to geomembranes.
- F. Geocomposites shall only be cut using approved cutting tools.
- G. The Contractor shall take any necessary precautions to prevent damage to underlying layers during placement of the geocomposite.
- H. During placement of geocomposites, care shall be taken not to entrap dirt or excessive dust that could cause clogging of the drainage system, and/or stones that could damage the adjacent geomembrane. If dirt or excessive dust is entrapped in the geocomposite, it shall

TECHNICAL SPECIFICATION

SECTION 02320-GEOCOMPOSITE DRAINAGE NET

be cleaned prior to the placement of soil cover material. In this regard, care shall be taken with the handling of sandbags, to prevent rupture or damage of the sandbags.

- I. Tools shall not be left in the geocomposite.
- J. In geocomposites, tearing the geotextile away from the geonet shall not be allowed except at seam locations in corners as approved by the Construction Manager.
- K. After deployment, all geocomposite shall be covered to prevent exposure to ultraviolet (UV) radiation (sunlight) within a maximum period of five (5) days.
- L. Placement of geocomposite and soil cover material on the geomembrane shall not proceed at an ambient temperature below zero (0) °C or above forty (40) °C.

3.2 JOINING

- A. Adjacent sections of geocomposite shall be overlapped according to the manufacturer's directions.
- B. Overlaps shall be secured by spot welding or tying. Acceptable tying devices include strings, plastic fasteners, or polymer braid. Tying devices shall be white or yellow for easy observation. Metallic devices are not allowed.
- C. Overlaps shall be secured every five (5) feet along slopes and on the floor of the landfill. Overlaps shall be secured every six (6) inches in anchor trenches. Along end to end seams, spot weld or tie two rows three (3) inches apart. Spot weld or tie each row at six (6) inch intervals, stagger weld or ties between rows.
- D. No horizontal seams shall be allowed on the top portion of the lined embankment within the 60 feet of the edge of the slope (at the transition from 2% to 3H:1V). Additionally, no horizontal seams shall be allowed on the side slopes.

3.3 CONSTRUCTION QUALITY ASSURANCE (CQA) SAMPLES

- A. CQA samples, three (3) feet in length, for the entire width of a roll, shall be obtained as determined by the CQA Consultant of material delivered to the site. Samples shall not be obtained from the first three (3) feet of the roll. The samples shall be identified by manufacturer's name, product identification, lot and roll number. The date, a unique sample number, and the machine direction shall also be noted. Testing of the CQA samples shall be tested and paid for by the Owner.
- B. The CQA Consultant shall provide the CQA samples to the QC laboratory to determine the appropriate properties specified by the Construction Manager in accordance with the methods specified in Tables 2 and 3. Samples not meeting the specified requirements shall result in the rejection of applicable rolls. As a minimum, rolls produced immediately prior to and immediately after the failed roll shall be tested for the same failed parameter. Testing shall continue until a minimum of three successive rolls on both sides of the original failing roll pass the failed parameter. Additional testing required for failed tests shall be paid for by the Contractor.

TECHNICAL SPECIFICATION

SECTION 02320-GEOCOMPOSITE DRAINAGE NET

3.4 DEFECTS AND REPAIRS

- A. Remove the damaged area of geocomposite.
- B. Cut a piece of geonet to fit into the repair area. Geonet shall fit into repair area to form a flush surface with the geocomposite. Cut geonet so that ribs are in the same orientation as existing geocomposite.
- C. Remove any dirt or other foreign material that may have entered the geocomposite.
- D. Place geonet patch into repair area.
- E. Place geotextile over the geonet patch. Cut geotextile to overlap existing geocomposite at least six (6) inches in all directions. Heat seam geotextile to geocomposite around its entire perimeter.

3.5 VISUAL INSPECTION AND EVALUATION

- A. Immediately prior to covering, the geocomposite, seams, and non-seam areas shall be visually inspected by the CQA Consultant for defects, holes, or damage due to weather conditions or construction activities.

3.6 PROTECTION AND BACKFILLING

- A. The deployed and seamed geocomposite shall be covered with the soil cover material within five (5) calendar days of acceptance. Wrinkles in the geocomposite shall be prevented from folding over during placement of drainage materials. Drainage material shall not be dropped onto the geosynthetics from a height greater than three (3) feet. The soil shall be pushed out over the geosynthetics in an upward tumbling motion. Soil shall be placed from the bottom of the slope upward. The initial loose soil lift thickness shall be one (1) foot. Equipment with ground pressures less than six (6) psi shall be used to place the first lift over the geocomposite drainage layer. A minimum of three (3) feet of soil shall be maintained between full-scale construction equipment tires/tracks and the geosynthetics during the covering process. Equipment placing soil cover material shall not stop abruptly, make sharp turns, spin their wheels, or travel at speeds exceeding five (5) mph.

****END OF SECTION****

TECHNCIAL SPECIFICATION

SECTION 02330-GEOTEXTILE

PART 1 GENERAL

1.1 SCOPE OF WORK

- A. The Work of this Section of the Specifications comprises supply of all labor, materials, and equipment, and performance of all Work necessary for the manufacturing, storage, delivery, installation, and testing of the geotextile, including installation as herein specified and as shown on the Construction Drawings. The geocomposite shall consist of a layer of geotextile thermally bonded to each side of a geonet. Requirements for geonet and geocomposite are contained in Section 02320, Geocomposite Drainage Net, of these specifications.

1.2 QUALIFICATIONS

- A. Manufacturer
 - 1. Manufacturer shall have produced the proposed geotextile material for at least ten (10) completed projects having a total minimum area of two million (2,000,000) square feet.
- B. Installer
 - 1. The Installer is responsible for field handling, deploying, seaming, anchoring, and field Quality Control (QC) testing of the geotextile. The Installer shall have installed the proposed geotextile material for at least ten (10) completed projects having a total minimum area of two million (2,000,000) square feet.

1.3 SUBMITTALS

- A. Raw Materials (Resin): Manufacturer's certified raw material test reports and a copy of the CQC certificates, a minimum of seven (7) days prior to shipment of geotextile to the site.
- B. Sheet Material: Manufacturer's certified sheet material test reports and a copy of the CQC certificates, a minimum of seven (7) days prior to shipment of geotextile to the site.
- C. Warrantee: Manufacturer's 10-year product warrantee, a minimum of seven (7) days prior to shipment of geomembrane to the site.
- D. Quality Control Procedures:
 - 1. Tests, Inspections, and Verifications
 - 2. Manufacturer's CQC manuals, a minimum of seven (7) days prior to geotextile shipment.
 - 3. Field Joining
 - 4. Installer's CQC manual, a minimum of seven (7) days prior to geotextile placement.

TECHNCIAL SPECIFICATION

SECTION 02330-GEOTEXTILE

- E. Statements
 - 1. Manufacturer's, qualification statements, including resumes of key personnel involved in the project, a minimum of seven (7) days prior to geotextile shipment.
 - 2. Installer's and CQC Inspector's qualification statements including resumes of key personnel involved in the project, a minimum of seven (7) days prior to geotextile placement.
- F. Samples:
 - 1. Geotextile CQC samples.

1.4 DELIVERY, STORAGE AND HANDLING

- A. The Construction Manager or the CQA Consultant shall be present during delivery and unloading of the geotextile. Each geotextile roll shall be labeled with the manufacturer's name, product identification number, roll number, and roll dimensions.
- B. Temporary storage at the project site shall be on a level surface, free of sharp objects where water cannot accumulate. The geotextile shall be protected from puncture, abrasion, excessive heat or cold, material degradation, or other damaging circumstances. Storage shall not result in crushing the core of roll goods or flattening of the rolls. Rolls shall not be stored more than two high. Ultraviolet sensitive materials shall be covered with a sacrificial opaque and waterproof covering or placed in a temporary shelter. Damaged geotextile shall be removed from the site and replaced with geotextile that meets the specified requirements.
- C. Rolls shall not be dragged, lifted by one end, or dropped. A pipe or solid bar, of sufficient strength to support the full weight of a roll without significant bending, shall be used for all handling activities. The diameter of the pipe or solid bar shall be small enough to be easily inserted through the core of the roll. Chains shall be used to link the ends of the pipe or bar to the ends of a spreader bar. The spreader bar shall be wide enough to prevent the chains from rubbing against the ends of the roll. Alternatively, a stinger bar protruding from the end of a forklift or other equipment may be used. The stinger bar shall be at least three-fourths ($3/4$) the length of the core and must be capable of supporting the full weight of the roll without significant bending. If recommended by the manufacturer, a sling handling method utilizing appropriate loading straps may be used.
- D. Handling of rolls of geotextile shall be performed in accordance with, ASTM D-4873 (Standard Guide for Identification, Storage, and Handling of Geotextiles). The Contractor shall be responsible for all damages incurred to the materials during handling. This includes, but is not limited to, physical damage to the geotextile resulting directly from equipment during off-loading, site transport, and deployment processes, or indirectly from the leakage or spillage of any fluids associated with the Contractor's activities.
- E. The outdoor exposure of geotextile rolls (without protective wrapping) shall not exceed the duration recommended by the Geotextile Manufacturer or six (6) months, whichever is

TECHNCIAL SPECIFICATION

SECTION 02330-GEOTEXTILE

less. The geotextile materials shall have consistent appearance and properties and shall be free of foreign matter. Geotextile rolls with patches or repairs made during or as a result of the manufacturing process shall not be accepted for use.

- F. Each geotextile roll shall be clearly labeled. Each label shall be in accordance with ASTM D-4873 (Standard Guide for Identification, Storage, and Handling of Geotextiles), and include, at a minimum: the Geotextile Manufacturer's name, product identification name/number, roll number, and the dimensions of the roll. If the geotextile is intended to be installed with a specific side against an adjacent material, then the geotextile shall be clearly marked to indicate the proper orientation. Any roll delivered to Site without the proper labeling shall, at the Construction Manager's recommendation, be rejected and removed from the Site by and at the expense of the Contractor.
- G. All geotextile rolls shall be enclosed in protective wrapping that is opaque and waterproof. The geotextile rolls shall be wrapped in the manufacturing facility. The protective wrapping shall prevent exposure of the geotextile to ultraviolet light, prevent it from moisture uptake and limit minor damage when handled and stored.

1.5 WEATHER LIMITATIONS

- A. The Contractor shall not attempt the deployment of geotextile during precipitation events or on slopes with frost or precipitation accumulation without prior authorization of the Construction Manager and implementation of proper safety precautions.

1.6 EQUIPMENT

- A. Equipment used in performance of the work shall be in accordance with the geotextile manufacturer's recommendations and shall be maintained in satisfactory working condition.

PART 2 PRODUCTS

2.1 GENERAL

- A. The geotextile shall be a non-woven, needle-punched, continuous filament, polyester or polypropylene material. All geotextile shall be free of oil, grease, and other foreign materials.

2.2 GEOTEXTILE PRODUCT

- A. The formulation used to manufacture the geotextile shall consist of at least ninety-five percent (95%) base resin, not more than three percent (3%) carbon black, and not more than two percent (2%) other additives. The Geotextile Manufacturer shall provide, in writing, the typical general composition of the geotextile, specifying the percentage of base resin, carbon black, and additives, respectively. The compounds comprising the non-

TECHNCIAL SPECIFICATION

SECTION 02330-GEOTEXTILE

carbon black additives to the resin formulation need not be specifically identified.

TABLE 1
GEOTEXTILE ROLL MATERIAL PROPERTIES (1)

PROPERTY	ASTM TEST METHOD	UNITS	QUALIFIER	VALUE
Mass Per Unit Area	D 5261 (4)	oz/yd ²	Minimum	10
Trapezoidal Tear Strength (2)	D 4533	lbs	Minimum	50
Grab Strength (2)	D 4632	lbs	Minimum	160
Puncture Strength	D 4833	lbs	Minimum	100
Mullen Burst Strength	D 3786	psi	Minimum	275
Wide Width Tensile Strength (Machine Direction)	D 4595	lbs/in	Minimum	150
Apparent Opening Size (AOS)	D 4751	Sieve Size	Minimum	50
Permeability (3)	D 4491	cm/sec	Minimum	0.1

NOTES:

1. The values in this table represent minimum roll values. In conformance testing, the roll value shall be determined as the average of the values obtained through testing the number of replicate specimens as specified by the appropriate ASTM method.
2. Measured in the weakest principal direction of the geotextile.
3. The results of testing in accordance with ASTM D4491 are typically reported as permittivity, but shall be expressed as at least one of the three specified terms (permeability, permittivity, water flow rate).
4. In some instances, some Geotextile Manufacturer's may include the previously used test methods for mass per unit area (D3776) in their printed matter.

2.3 CONSTRUCTION QUALITY CONTROL

A. Manufacturing, Sampling, and Testing

1. Raw materials shall be tested in accordance with the approved MQC manual. Any raw material which fails to meet the geotextile manufacturer's specified physical properties shall not be used in manufacturing the sheet.
2. Geotextile sheets shall be tested in accordance with the approved MQC manual. Sheets not meeting the minimum requirements specified in Table 1 shall not be sent to the site.

TECHNCIAL SPECIFICATION

SECTION 02330-GEOTEXTILE

PART 3 EXECUTION

3.1 HANDLING AND PLACEMENT

- A. Geotextile panels shall be placed in a controlled manner such that they are not damaged and that the deployment process does not damage any other materials. Any such damage shall be repaired by and at the expense of the Contractor.
- B. Personnel working on the geotextile shall not smoke, wear damaging shoes, or engage in other activities which could damage the material. The Contractor shall provide protection to the geotextile from any equipment or concentrated personnel traffic associated with construction. Any such damage to the geotextile or other geosynthetic layers resulting from such activities shall be repaired by and at the expense of the Contractor. The Contractor's Installation Quality Control Procedures Manual shall address the safety precautions to be taken and the safety equipment to be used while deploying and seaming geotextiles.
- C. Geotextile panels shall be deployed in such a manner as to be in contact with the material directly beneath it and preclude folds, wrinkles which may become folds, and bridging. Any wrinkle, fold or bridging that may propagate into other geosynthetic or soil layers shall be removed by repositioning of the geotextile or cutting and repairing it in accordance with this Section of the Specifications.
- D. Geotextile panels on slopes greater than ten percent (10%) shall have, no end-to-end overlaps (cross seams) along the slope length unless otherwise approved by the Construction Manager. Geotextile panels shall extend a minimum of five (5) feet beyond the toe of slope.
- E. If lightly colored geotextile is used, precautions shall be taken to avoid "snow blindness" of personnel.
- F. The geotextile, as well as the geomembrane and geonet shall be free of mud, dust, dirt, and debris that could damage the geosynthetic layers or contribute to clogging of the drainage system.
- G. The Contractor shall clean the work area daily, by removing scrap material and other debris associated with geotextile installation activities, and disposing of it in proper receptacles.

3.2 SEAMING

- A. All seams shall be continuously sewn, unless otherwise approved by the Construction Manager. No cross seams, are allowed on slopes steeper than ten percent (10%). Geotextiles shall be overlapped a minimum of six (6) inches prior to seaming. The stitching shall be a minimum of one (1) inch from the selvage (exposed edge of the material).
- B. The geotextile seams shall, at a minimum, be a flat or "prayer" type seam with one (1) row

TECHNCIAL SPECIFICATION

SECTION 02330-GEOTEXTILE

of a two-thread locking chain stitch. Cross seams (only allowed on slopes less than ten percent (10%)) shall be sewn with two rows of two-thread locking chain stitch. The thread used in sewing shall be of a polymeric material with a minimum rated tensile break strength in excess of 15 pounds and having chemical resistance (to leachate) and ultraviolet resistance equal to or exceeding that of the geotextile.

- C. Seaming shall not be attempted in the presence of frost, condensation, or any precipitation events unless adequate measures are taken to ensure seam quality and approved by the Construction Manager, and proper safety precautions are implemented by the Contractor. All geotextiles seams shall be exposed to allow for visual observation and documentation.
- D. The Contractor shall take measures to prevent soil, granular materials, or foreign materials from entering or becoming trapped beneath the geotextile both during and following installation. The Contractor's Installation Quality Control Procedures Manual shall address the safety equipment and procedures to be employed during seaming operations on slopes.

3.3 CONSTRUCTION QUALITY ASSURANCE

- A. CQA samples, three (3) feet in length, for the entire width of a roll, shall be obtained of material delivered to the site. Samples shall not be obtained from the first three (3) feet of the roll. The samples shall be identified by manufacturer's name, product identification, lot and roll number. The date, a unique sample number, and the machine direction shall also be noted.
- B. The CQA Consultant shall provide the CQA samples to the QC laboratory to determine the specified properties in accordance with the methods specified in Table 1. Samples not meeting the specified requirements shall result in the rejection of applicable rolls. As a minimum, rolls produced immediately prior to and immediately after the failed roll shall be tested for the same failed parameter. Testing shall continue until a minimum of three successive rolls on both sides of the original failing roll pass the failed parameter. Additional testing required for failed tests shall be paid for by the Contractor.

*****END OF SECTION*****

TECHNICAL SPECIFICATION

SECTION 02431 -- DECONTAMINATION

PART 1 GENERAL

1.1 DESCRIPTION OF WORK

- A. This section describes requirements for decontamination of vehicles and/or construction equipment and for the handling of the liquids generated during decontamination procedures. Decontamination will be required when equipment contacts PCB containing soil materials. The Contractor shall furnish all materials, equipment, transportation, a competent supervisor, and labor necessary to complete the Work.
- B. The decontamination operation shall be performed on a Decontamination Pad to be designed and constructed by the Contractor and liquids generated by such decontamination procedures shall be retained within the project area.
- C. Contractor shall comply with applicable codes, ordinances, rules, regulations and laws of local, State, and Federal authorities having jurisdiction.

1.2 SUBMITTALS

- A. The Contractor shall design the Decontamination Pad, and submit the design to the Construction Manager or the Owner for review and approval fifteen (15) days before mobilization of equipment to the site occurs.

PART 2 PRODUCTS

Not Used.

PART 3 EXECUTION

3.1 PRESSURE WASHING

- A. The Contractor shall use steam and, if necessary, high pressure water to wash vehicles and/or construction equipment exiting the project site. If necessary, soil or other solid material adhered to the vehicles and/or construction equipment shall be removed by scraping with hand equipment prior to washing. The equipment shall be thoroughly washed with additional brushing or washing as needed to remove visible residues.

3.2 HANDLING OF WASH WATER

- A. The handling of wash water shall be done in a manner such that the water will be contained on the site and not be allowed to flow off the site as surface water discharge, unless permitted for dewatering. Any damage or pollution to adjacent soil or surface waters due to the Contractor's actions or negligence under this requirement, or any fines, penalties, costs of clean-up or reconstruction required as a result thereof, shall be at the sole expense of the Contractor. The Contractor

TECHNICAL SPECIFICATION

SECTION 02431 -- DECONTAMINATION

shall immediately remedy, clean-up, and correct any conditions as a result of its pollution of surface waters.

- B. The wash water shall be collected in a sump area so that solids can be separated from the wash water by gravity or by filtering.
- C. All soil sediments collected within the decontamination pad shall be disposed of on-site at an area designated by the Construction Manager.

END OF SECTION

subject to 761.79(b)(3)

TECHNICAL SPECIFICATION

SECTION 02525 – ACCESS ROAD CONSTRUCTION

PART 1 GENERAL

1.1 SUMMARY

- A. The Work of this Section of the Specifications comprises all labor, materials, equipment, and performance of all work necessary for excavating, processing, loading, transporting, dumping, spreading, and compacting of road fill materials on the Site access roads shown on the Drawings.

PART 2 PRODUCTS

2.1 GRADED AGGREGATE BASE MATERIAL

- A. The graded aggregate for road fill materials shall be of uniform quality throughout and meet the requirements of Section 801 of the Alabama DOT Standard Specifications, latest edition, for highway and bridge construction. The graded aggregate shall be produced from an approved source or deposit which shall yield a satisfactory mixture conforming to all requirements of these Specifications after it has been crushed or processed as a part of the mining operations.
- B. The graded aggregate material shall be produced from sources that meet the requirements of Section 801.03 of Alabama DOT Specifications, latest edition.
- C. The graded aggregate road fill material shall conform to the gradation requirements of a graded aggregate base as follows:

Sieve Size	Percentage Passing by Weight
1"	70-100
1/2"	50-85
No. 4	25-60
No. 200	0-10

2.2 RIP-RAP

- A. Stone materials for rip-rap lined slopes shall be in accordance with the Stone Rip-rap Specification, Section 02230.

PART 3 EXECUTION

3.1 INSTALLATION

- A. Preparation Of Subbase For Road Fill
 - 1. When the earth foundation for road fill has been placed to a clean, rough planar surface, compact entire foundation area for road base course by a minimum of six (6) complete passes of a vibratory steel drum roller

TECHNICAL SPECIFICATION

SECTION 02525 – ACCESS ROAD CONSTRUCTION

weighing no more than eight tons. The roller shall travel at speeds not to exceed five (5) miles per hour.

2. Construction Manager will approve road foundation before placement of graded aggregate base materials commences and after surfaces to receive such materials have been prepared as specified. Any soft spots or other unsuitable areas, as identified by the Construction Manager, shall be removed and replaced with backfill material approved by the Construction Manager.
3. A 10 oz./sq. yd. nonwoven geotextile fabric shall be placed on the foundation subgrade prior to placement of graded aggregate base materials. The geotextile fabric shall meet or exceed the requirements in Section 02330 of these Specifications.

B. Placing Road Fill

1. Placing of graded aggregate base materials shall be directed to obtain homogeneous fill, which is free of horizontal stratifications and of lenses or pockets of materials which do not satisfy requirements of this Section of the Specifications. Spread graded aggregate base materials in horizontal layers of uniform thickness by bulldozers or other approved means. Unless otherwise specified, thickness of graded aggregate base layers after compaction shall not exceed six (6) inches. Take care to prevent graded aggregate materials from being contaminated by mixing with adjacent materials. Remove graded aggregate materials which have been contaminated with deleterious materials.

C. Graded Aggregate Base Compaction

1. The moisture content of the mixture of graded aggregate materials at the time of compaction shall be uniformly distributed and shall be adequate to allow compaction to the specified density.
2. After the material placed has been shaped to line, grade and cross-section, it shall be rolled until the fill has been uniformly compacted.
3. The compacted fill shall have sufficient stability to support construction equipment without pumping regardless of compaction. If the road fill material becomes unstable as a result of too much moisture, the road fill material and the underlying subgrade if necessary shall be dried and reworked to a moisture content that will provide stability and compaction.
4. Compact material by approved vibrating roller or accepted alternative to 98% of the Maximum Dry Density (Standard Proctor – ASTM D638).
5. After the graded aggregate material has been satisfactorily compacted, the surface shall again be shaped to line, grade and cross-section. Water shall be added, if necessary, in order to develop the proper moisture content. It shall then be rolled, beginning at the edges and working toward the center, until the surface is smooth, closely knit, free from

TECHNICAL SPECIFICATION

SECTION 02525 – ACCESS ROAD CONSTRUCTION

cracks, conforming to the prescribed line, grade and cross-section, within the limits specified.

6. At all places not accessible to the roller, the required compaction shall be secured by means of approved mechanical tampers. The same density requirements as stated above apply.

*****END OF SECTION*****

TECHNICAL SPECIFICATION

SECTION 02936 - GRASSING AND MULCHING

PART 1 - GENERAL

1.1 SUMMARY

- A. The Work of this Section of the Specifications shall consist of furnishing labor, equipment and materials and performing all operations necessary in preparing seedbed, seeding, fertilizing, liming, and mulching areas as directed by the Construction Manager.

PART 2 - PRODUCTS

2.1 MATERIALS

- A. Fertilizer shall be 10-10-10 (@ 400 lbs/acre) and 4-12-12 (@ 600 lbs/acre), Total Nitrogen, available Phosphoric Acid and water-soluble Potash, per Section 860.12 (c) of the Alabama Highway Department Standard Specifications for Highway Construction.
- B. Liming shall be pulverized lime (@ 2 tons/acre) or hydrated lime (@ 1 ton/acre), per Section 860.12 (d) of the Alabama Highway Department Standard Specifications for Highway Construction.
- C. Mulch shall be Class A Mulch, per Section 860.3 (b) of the Alabama Highway Department Standard Specifications for Highway Construction.
- D. The seed mixture to be used shall comply with the following requirements:

<u>April</u> through <u>June</u>	Kentucky 31 or Alta Fescue	30 lbs/acre
	Kobe Lespedeza	30 lbs/acre
	Bermuda grass (Hulled)	20 lbs/acre
<u>July</u> through <u>August</u>	Pensacola Bahiagrass	30 lbs/acre
	Reseeding Crimson Clover	35 lbs/acre
	Bermuda grass (hulled)	25 lbs/acre
<u>September</u> through <u>March</u>	Kentucky 31 or Alta Fescue	25 lbs/acre
	Bermuda grass (unhulled)	25 lbs/acre
	Annual Ryegrass	25 lbs/acre
	Reseeding Crimson Clover	30 lbs/acre

TECHNICAL SPECIFICATION

SECTION 02936 - GRASSING AND MULCHING

PART 3 - EXECUTION

3.1 GENERAL

- A. The Contractor shall grass all areas as directed by the Construction Manager. The entire area shall be smoothed with a drag and all clods broken up. All deleterious material, large stones, roots, limbs, and other debris shall be removed to leave a smooth area that would be suitable for mowing.
- B. Grass seed shall be planted at the rates specified in the previous Section. Fertilizer shall be applied and mixed into the top soil at the rate specified in the previous Section.
- C. Grassing (by seeding) shall be completed as soon as practical after finish grading is completed in order to minimize erosion from rainfall and run-off. Any erosion occurring in grassed areas shall be immediately repaired.
- D. Seed, fertilizer, mulch, and periodic watering shall be applied in adequate quantities to assure a satisfactory ground cover over the entire disturbed area of construction operations. A satisfactory stand of grass is defined as a full cover, over the seeded area, of live and growing grass with no bare spots larger than two square feet.
- E. Seed and fertilizer mix shall be as described in Section 2.1. All planting and seeding shall be watered thoroughly as soon as completed and shall be watered at least twice daily, or more often if necessary to provide continuous growth without setback until all growth from seed is thoroughly established.
 - 1. Seeded areas shall be immediately mulched to aid in the establishment of vegetation. The mulching material will be of good quality, free of seeds of competing plants, and applied at the rate of two (2) tons per acre.
 - 2. Straw or hay mulch will be applied uniformly over the area, leaving about 25 percent of the ground surface exposed. It must be spread within 24 hours after seeding is done. The spreading must be done by blower-type or other mulch-spreading equipment or by hand and anchored by pressing the mulch into the soil. All accessible mulched areas shall have mulch consolidated into the soil with a mulch stabilizer, and slope areas shall be tucked on the contour. Crawler type or dual wheel tractors shall be used for the mulching operation. Equipment shall be operated in a manner to minimize displacement of the soil and disturbance of the design cross section.
- F. The Contractor shall be responsible to ensure that grass is well established within two months of substantial completion of the project. The Contractor shall guarantee the established grass for twelve (12) months.

3.2 FERTILIZER

- A. Apply fertilizer per Section 651.01 and 651.03 of the Alabama Highway

CCWTPP

TECHNICAL SPECIFICATION

SECTION 02936 - GRASSING AND MULCHING

Department Standard Specifications for Highway Construction.

3.3 SEEDING

A. Seeding shall be done as per Section 652.01 and 652.03 of the Alabama Highway Department Standard Specifications for Highway Construction.

3.4 MULCHING

A. Mulching shall be applied as per Section 656.01 and 656.03 of the Alabama Highway Department Standard Specifications for Highway Construction.

**** END OF SECTION ****

Appendix D - Construction Quality Assurance Plan



CONSTRUCTION QUALITY ASSURANCE PLAN
CHOCOLOCCO CREEK
WASTEWATER TREATMENT PLANT PROJECT
ANNISTON, ALABAMA

JANUARY 2003

Submitted to:

Solutia Inc.
702 Clydesdale Avenue
Anniston, Alabama 36201-5390

Prepared by:

Golder Associates Inc.
3730 Chamblee Tucker Road
Atlanta, Georgia 30341

TABLE OF CONTENTS

<u>SECTION</u>	<u>PAGE</u>
1.0 INTRODUCTION.....	1
1.1 Purpose and Scope	1
1.2 Construction Quality Assurance Program	2
2.0 PROJECT TEAM ORGANIZATION AND RESPONSIBILITIES.....	4
2.1 Owner.....	4
2.2 Contractor	4
2.3 Construction Manager.....	5
2.4 Construction Quality Assurance Consultant.....	6
3.0 CONSTRUCTION ACTIVITIES	8
3.1 Earthworks	8
3.2 Geosynthetics.....	8
3.3 Miscellaneous	8
4.0 QUALITY ASSURANCE DOCUMENTATION.....	9
4.1 Earthwork.....	9
4.1.1 Pre-Construction Testing	9
4.1.2 Construction Quality Control Testing	10
4.1.3 Construction Monitoring.....	11
4.1.4 PCB-Containing Soil Excavation/Relocation	11
4.2 Geosynthetics.....	12
4.2.1 Conformance Testing.....	12
4.2.2 Construction Monitoring and Testing.....	14
4.2.3 Geomembrane Monitoring and Testing	15
4.2.4 Geotextile and Geosynthetic Drainage Strip Monitoring	17
4.3 Gravel Toe Drain	18
5.0 RECORDS AND REPORTING	19
5.1 Contract Drawings	19
5.2 Contract Submittals.....	19
5.3 Daily Records	19
5.4 Construction Problem and Corrective Measure Reports	20
5.5 Photographic Records	20
5.6 Final Documentation Report.....	20
5.7 Records Storage	21
5.8 Plan Modification Procedure	21

1.0 INTRODUCTION

1.1 Purpose and Scope

This Construction Quality Assurance Plan (CQAP) has been prepared by Golder Associates Inc. (Golder Associates) on behalf of Solutia for the project involving the consolidation, relocation, and covering of the stockpiled soil at the Choccolocco Creek Wastewater Treatment Plant in Anniston, Alabama.

This CQAP describes the following elements:

- Responsibilities and authorities of the organizations and key personnel involved in the design and construction of the cover system;
- Protocols for sampling and testing used to monitor construction;
- Identification of construction quality assurance (CQA) sampling activities including sample size, locations, and testing frequencies; and,
- Reporting requirements for CQA activities including summary reports, inspection data sheets, problem identification and corrective measures reports, design acceptance reports, and final documentation. In addition, provisions for final storage of all records are specified.

Reference is made throughout this CQAP to the project Drawings and Technical Specifications, which, along with the contractual specifications and requirements, will comprise the project Contract Documents. Details of materials, construction requirements, and procedures are included in the Technical Specifications, which are included by reference in this CQAP.

This CQAP addresses construction quality assurance (CQA), which differs from construction quality control (CQC). In general, CQA refers to measures taken to assess if the Contractor is in compliance with the plans and specifications for a project. CQC refers to measures taken by the Contractor to determine compliance with the requirements for materials and workmanship as stated in the plans and specifications for the project. This CQAP is independent of QC programs conducted by manufacturers and the cover system Contractor and subcontractors that are described in the Technical Specifications.

1.2 Construction Quality Assurance Program

The CQA program is a planned system of activities that provides assurance that a project is constructed in accordance with the intent of the Contract Documents. It includes inspections, verifications, audits, and evaluations of materials and workmanship necessary to determine and document the quality of the constructed work.

The basic components of the CQA program are:

- Preparation of a CQA Plan;
- Pre-construction review of project components;
- Conformance testing of geosynthetic and soil materials;
- Field monitoring and survey control of grades;
- Field monitoring and testing of soil components during placement and compaction;
- Field monitoring of the placement of cover system erosion protection (rip-rap, hale bales, silt fences, etc.);
- Field monitoring of the removal/relocation of PCB-containing soils which are presently outside the limits of the cover system;
- Preparation of Daily Reports;
- Review of technical and laboratory data;
- Final walk over and favorable review of the completed work; and,
- Compilation and presentation of applicable data, logs, as-built documents, photographs, and comments into a Final Record Documentation Report, which certifies that the construction was completed in accordance with the intent of the Contract Drawings and Technical Specifications.

These CQAP guidelines provide for qualified personnel to monitor the progress and quality of construction. This program is intended to provide an objective overview of construction progress and to identify potential deficiencies or problem areas during construction. The CQA program can also assist the cover system Contractor in completing the project more efficiently by requiring compliance with quality control specifications before the project proceeds to the extent where substantial work may have to be redone in order to correct a defect.

The CQAP identifies the personnel involved in CQA, and describes roles and responsibilities of the associated parties, QA reporting, and record storage requirements. The CQAP also calls for a narrative describing construction, test results, and record drawings to be compiled into a Final Record Documentation Report signed by a Professional Engineer, which certifies that construction was completed in conformance with the Contract Drawings, Technical Specifications, and approved modifications.

2.0 PROJECT TEAM ORGANIZATION AND RESPONSIBILITIES

This section describes the organization and individual responsibilities during the cover system. The project organization is illustrated in Figure 1.

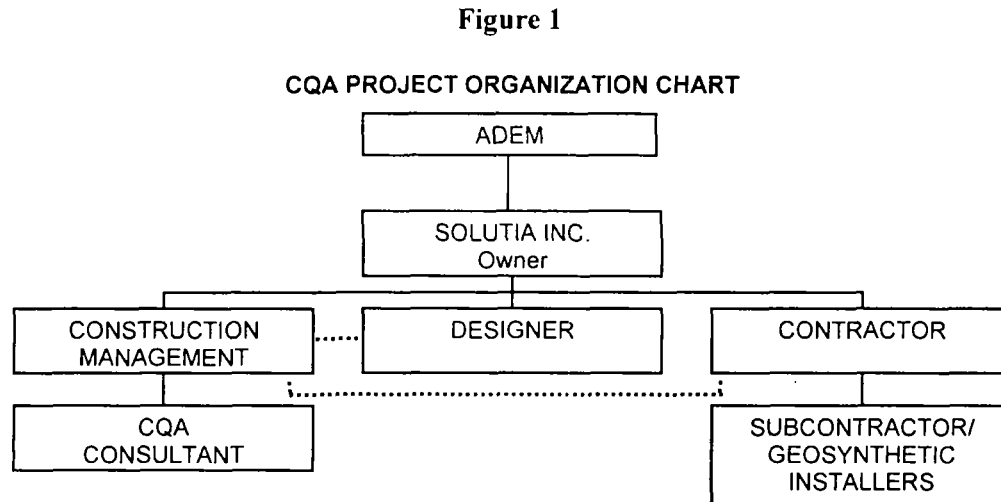

2.1 Owner

Solutia Inc. (Owner) will be responsible for the implementation of the project. Solutia will be responsible for the overall coordination and management of activities. All references to Solutia in this document will implicitly include the Construction Manager as the Owner's Representative.

General responsibilities of the Owner include:

- Coordinate directly with the ADEM during the construction, including any concerns;
- Approve/disapprove any substantive changes proposed by the Contractor that differ from the bid, specifications, drawings or specifications;
- Negotiate any changes to the contract(s), with the Contractor, based upon recommendations by the Construction Manager; and
- Resolve any design clarifications or interpretations with the Contractor.

2.2 Contractor

Solutia will select the Contractor. The selected Contractor will be qualified to undertake the types of construction activities to be implemented.

The Contractor will assign a Project Manager / Project Superintendent (Project Manager) as the responsible person in charge of all aspects of the project. The Project Manager will have a background in engineering or construction management with significant experience in construction and contract administration. The Contractor will be responsible for constructing the work in accordance with the intent of the Contract Documents, including implementation of the Health and Safety Plan.

The Contractor may engage various subcontractors to implement the work. The subcontractors will each provide a field supervisor who will report directly to the Contractor's Project Manager.

Upon completion of the project, the Contractor will provide record drawings to the Construction Manager for review and approval, and then provide final record drawings to the Construction Manager for transmittal to the Owner.

2.3 Construction Manager

The responsibilities of the Construction Manager during cover system construction include the following:

- Prepare an agenda for, preside at, and record project meeting minutes, including pre-construction and weekly progress meetings, substantial completion, or other meetings as necessary;
- Monitor and coordinate the Contractor's work in relation to the schedule and conformance with the Contract Documents;
- Work with the Contractor to document that the required QC testing has been performed in accordance with the Technical Specifications;
- Receive and review shop drawings and other material submittals from the Contractor and submit to the Owner, if required, for review. Coordinate with the Contractor to incorporate the Owner's and Construction Manager review comments;
- Schedule and coordinate QA monitoring activities;
- Assist the Owner in the selection of a Contractor;
- Review all design and specification changes;
- Provide clarifications to the Contract Drawings and Technical Specifications;
- Be present on-site for monitoring of selected cover system construction activities;

- Review submittals required by the Contract Drawings and Technical Specifications including QC tests;
- Prepare periodic construction progress reports for distribution to the project team; and,
- Maintain on-site project record drawings and project file for storing of originals or copies of reports generated during cover system construction.

Design and specification changes will be transmitted through the Construction Manager and the CQA Consultant for review and approval. Materials and construction changes proposed during construction will be evaluated for compliance with the intent of the Contract Drawings and Technical Specifications.

2.4 Construction Quality Assurance Consultant

The CQA Consultant will be responsible for overseeing and implementing the CQA program at the site. The CQA Consultant will perform the CQA tasks required by this CQAP and document that the project construction has been completed in general conformance with the Contract Documents. The CQA Consultant is also responsible for reviewing each stage of construction activities. The CQA Consultant will report directly to the Construction Manager. The CQA Consultant may or may not be an employee of the Owner or the Construction Manager. Responsibilities of the CQA Consultant include the following:

- Review of the Contract Drawings, Technical Specifications, CQC submittals, and related work plans to verify compliance with CQAP requirements;
- Work with the Construction Manager to review construction activities with the Contractor;
- Coordinate and schedule CQA testing with construction activities;
- Observe the construction quality control (CQC) operations performed by the Contractor and Contractor's subcontractors;
- Review, in conjunction with the Construction Manager, corrective measures to be implemented during construction when deviations from the CQAP occur;
- Review CQC activities to help ensure that testing and documentation are complete, accurate and in general accordance with the Contract Documents;
- Monitor and document geosynthetic material installation, non-destructive and destructive testing, and seaming and repair operations;
- Work with the Construction Manager to determine that testing equipment used and tests performed are in accordance with the Technical Specifications and industry standards;

- Observe, document, and report on tests;
- Report any identified deficiencies not satisfactorily corrected to the Construction Manager;
- Prepare daily CQA construction reports;
- Maintain an on-site project file for storing the originals or copies of all CQA data sheets and reports generated during construction;
- Coordinate with the Construction Manager to review quality assurance activities and data. Submit weekly quality assurance reports to the Construction Manager during the installation of the geosynthetics and meet with the Construction Manager, as necessary;
- Verify as-built surveying by the Contractor in accordance with the Contract Documents; and,
- Preparation of the Final Documentation Report at the completion of the project.

3.0 CONSTRUCTION ACTIVITIES

The following is a brief discussion of the Contractor's major construction activities to be monitored. The monitoring activities will be performed by the Construction Manager and the CQA Consultant.

3.1 Earthworks

Earthwork activities include:

- Provision of soil materials, including proper QC documentation, for use as fill, cover, etc. in accordance with the specifications;
- Excavation and placement of PCB-containing soils,
- Fill placement, compaction, field testing, and grading of relocated PCB-containing soils materials, and structural fill materials;
- Placement of the soil cover and topsoil over the low permeability layer of the cover system; and,
- Placement of rip-rap armor and erosion protection structures.

3.2 Geosynthetics

Geosynthetics installation activities include:

- Provision of geosynthetics, including proper QC documentation, for use in areas capped with a geomembrane;
- Installation of the geomembrane as part of the cover system;
- Installation of the geosynthetic drainage layer;
- Installation of geotextiles on the cover, access roads, etc.

3.3 Miscellaneous

In addition to the activities described above, additional activities are also required, including the establishment of permanent vegetation on the completed landfill cover system and other areas disturbed by construction activities.

4.0 QUALITY ASSURANCE DOCUMENTATION

The following sections present minimum requirements of the CQA monitoring and testing documentation program to be performed by the CQA Consultant in conjunction with the Contractor. This monitoring and testing program is intended to supplement the Technical Specifications. The Contractor will be responsible for strict compliance with the Contract Documents. Minor changes to the Contract Documents must be approved by the Construction Manager. Major changes to the Contract Documents must be approved by the Construction Manager, the Owner, and ADEM.

4.1 Earthwork

The earthwork testing program consists of pre-construction and construction evaluation and/or testing of on-site soils, imported soil and gravel/crushed stone, including the material for the soil cover, gravel road material, gravel bedding, rip-rap, etc. The earthworks testing program will be implemented by the Contractor as part of the construction activities. Prior to, and during construction, Construction Quality Control tests performed by the Contractor (or his CQC Consultant) on all earthworks will be evaluated by the Construction Manager and/or the CQA Consultant to determine if it meets the specification requirements. The CQA Consultant may, at the Owner's request, independently test duplicate samples and/or locations for Quality Assurance.

4.1.1 Pre-Construction Testing

Prior to initiation of construction, pre-construction testing will be performed by the Contractor on the imported materials to determine whether they meet requirements listed in the Technical Specifications. Soil samples will be provided from each proposed source. The specific tests to be performed, including testing frequency, for each material type are presented in Table 4-1. Soil samples will be obtained in accordance with American Society for Testing and Materials (ASTM) standards ASTM D75 and ASTM D420, and will be tested by a geotechnical testing laboratory approved by the Construction Manager.

TABLE 4-1
PRE-CONSTRUCTION TESTING OF IMPORTED MATERIALS
MINIMUM FREQUENCIES¹

Test and Method	Soil Cover/Structural Fill/PCB-Containing soil fill (cy)	Topsoil (cy)	Stone Aggregates (cy)	Rip-rap (cy)
Particle Size ² (ASTM D422)	10,000	5,000	---	---
Particle Size ² (ASTM C136)	---	---	5,000	---
Particle Size ² (ASTM D5519)	---	---	---	5,000
Natural Moisture Content ³ (ASTM D2216)	5,000	--	--	--
Standard Proctor (ASTM D698)	10,000	---	--	--
pH (ASTM D4972)	--	5,000	--	--
Organic Content (ASTM D2974)	--	5,000	--	--
Soil Fertility (Baker or LaMotte)	---	5,000	---	---
Specific Gravity (ASTM D854)	---	---	--	5,000

¹ Specific frequency refers to one test per the presented volume or one per material type or source, which ever is greater.

² ASTM D422 is applicable for earth fill and topsoil. ASTM C136 is applicable to dense-graded aggregate. ASTM D5519 is applicable to rip-rap. Use the USCS for description and identification (ASTM D2488). Rip-rap gradation based on visual observation.

³ Natural moisture content.

A complete listing of all of the soil testing requirements is provided in Technical Specification.

In addition to the above, imported soil material will be analyzed to determine that PCB concentrations do not exceed one (1) mg/kg. Testing procedures to determine chemical contamination are addressed in the appropriate sections of the Technical Specifications.

4.1.2 Construction Quality Control Testing

The tests to be performed for each material type, including testing frequency, are presented in Table 4-2. The testing frequencies specified in Table 4-2 are minimum and may be increased by the Construction Manager or CQA Consultant if construction conditions warrant.

**TABLE 4-2
CONSTRUCTION TESTING - MINIMUM FREQUENCIES¹**

Test and Method	Embankment Fill/ Structural Fill	Soil Cover
Standard Proctor (ASTM D698)	5,000 or visual change in soil texture	--
Permeability (ASTM D 5094)	--	1 per every two acres
In-Place Density (ASTM D2922)	5 per acre per lift on average over the project duration, and at least 3 per day or lift	--
Water Content (ASTM D3017)	5 per acre per lift on average over the project duration, and at least 3 per day or lift	--

¹Specific frequency refers to one test per the presented frequency or one per material type, whichever is greater.

Earthfill materials will be placed in accordance with the Technical Specifications, Sections 02221, and 02267.

4.1.3 Construction Monitoring

All earthworks will be observed by the Construction Manager to verify that the construction is completed in accordance with the Contract Documents. The Contractor will be responsible for establishing the design lines and grades. Visual observations or CQA surveying, as appropriate throughout the construction process, will be conducted to evaluate whether the materials are placed to the lines and grades as shown on the Contract Drawings. The CQA Consultant will make periodic visits at critical points during the earthworks activities, for instance, once the subgrade is ready for placement of the first lift of the embankment fill; when the embankment is almost completed and final grading is taking place; during placement of the soil cover on the side slopes; and/or at any other time as may be required to identify inadequate construction methodologies or materials that may adversely impact the performance of the earthworks.

4.1.4 PCB-Containing Soil Excavation/Relocation

PCB-containing soil material within the existing stockpile will be excavated and relocated within the limits of the cover system. The approximate areal extent of the PCB-containing soils to be relocated is indicated on the Drawings. However, the actual depth of the PCB-containing soils will be defined as the excavation proceeds.

4.2 Geosynthetics

The CQA program for geosynthetics consists of reviewing the Geosynthetics Installer's QC submittals, material conformance testing, construction monitoring, and testing. The types of geosynthetics used in the construction of the remedy include a smooth 40-mil thick High Density Polyethylene (HDPE) geomembrane, non-woven geotextiles at various locations, and a geosynthetic drainage layer below the cover soil layer. The geosynthetic QC submittals and material conformance testing requirements are defined in the Technical Specifications. Prior to and during construction, these geosynthetics will be sampled and tested to determine if the materials meet the requirements as listed in the Technical Specifications. Conformance testing will be performed by a Geosynthetics Accreditation Institute (GAI) accredited Geosynthetics Laboratory, as approved by the Construction Manager.

4.2.1 Conformance Testing

Prior to geosynthetics installation, samples of the geosynthetics will be obtained for conformance testing by the CQA Consultant. The conformance testing minimum frequency will be at a rate of 1 per 100,000 square feet from material delivered to the Site, or one sample per lot, whichever results in the greater number of conformance samples. Samples will be taken across the entire width of the roll and will not include the first "wrap" or a minimum of 3 feet. The samples will be about 3 feet long in the machine direction by the roll width. The CQA Consultant will mark the machine direction, roll number, project specific information, and date the sample was obtained, on the sample and forward the sample to the approved geosynthetics laboratory. The minimum required geosynthetic conformance tests are presented in Tables 4-3, 4-4, and 4-5, below.

**TABLE 4-3
GEOMEMBRANE CONFORMANCE TESTING**

Test	Test Method	Frequency (sf)¹
Density	(ASTM D1505)	1/100,000
Environmental Stress Crack Resistance	(ASTM D1693)	1,100,000
Carbon Black Content	(ASTM D1603)	1/100,000
Core Thickness	(ASTM D5199)	1/100,000
Tensile Properties	(ASTM D638)	1/100,000
Dimensional Stability	(ASTM D1204)	1/100,000
Puncture Resistance	(ASTM D4833)	1/100,000
Carbon Black Dispersion	(ASTM D5596)	1/100,000
Low Temperature Brittleness	(ASTM D476)	1/100,000
Tear Resistance	(ASTM D1004)	1/100,000

**TABLE 4-4
GEOTEXTILE CONFORMANCE TESTING**

Test	Test Method	Frequency (sf)¹
Mass per unit area	(ASTM D5261)	1/100,000
Grab Tensile Strength and Elongation	(ASTM D4632)	1/100,000
Puncture Strength	(ASTM D4833)	1/100,000
Burst Strength	(ASTM D3786)	1/100,000
Trapezoidal Tear	(ASTM D4533)	1/100,000
Apparent Opening Size	(ASTM D4751)	1/100,000

**TABLE 4-5
GEOSYNTHETIC DRAINAGE LAYER CONFORMANCE TESTING**

Test	Test Method	Frequency (sf)¹
Thickness	(ASTM D5199)	1/20,000
Transmissivity	(ASTM D4716)	1/150,000

¹ Specified frequency or one per lot, whichever is greater.

All conformance tests will be performed in accordance with the Technical Specifications. The CQA Consultant will review the test results and will report any nonconformance to the Construction Manager, the Contractor, and the Geosynthetics Installer.

4.2.2 Construction Monitoring and Testing

All geosynthetic components will be tested. The CQA Consultant will work to verify adequate Contractor's construction methodologies or materials. Visual observations or CQA surveying throughout the construction process will be made to evaluate whether materials are placed to the lines and grades as shown on the Drawings.

The CQA Consultant will review the following Contractor's Geosynthetics Installer documentation:

- QC documentation recorded during installation;
- daily reports detailing arrival and departure times, the personnel present on-site, the progress of the work, the arrival of materials, and any problems encountered; and,
- subgrade surface acceptance certificates for each area to be covered by the geosynthetics, signed by the Geosynthetics Installer's Superintendent and the Contractor.

The CQA Consultant will observe and document the following items related to geosynthetics installation:

- delivery and unloading of geosynthetic materials to the Site to verify that the materials are in good condition and properly labeled;
- geosynthetic storage area shall be uniform and free of possible sources of damage, such as mud, dirt, debris, and dust;
- geosynthetic packaging identification slips for verification and generation of an on-site materials inventory;
- subgrade conditions prior to geosynthetics installation. Verify that any identified deficiencies (e.g., surface irregularities, loose soil, protrusions, in-place construction stakes, excessively soft areas, stones, desiccation cracks) are corrected;
- lines and grades have been verified by the Contractor's surveyor;
- handling of geosynthetic materials from storage to the work area;
- temporary and permanent anchoring of geosynthetics; and,

- required overlap distances are maintained.

4.2.3 Geomembrane Monitoring and Testing

During installation, the CQA Consultant will observe and document the Contractor's geomembrane deployment, trial seams, field seams, non-destructive and destructive seam testing, and repairs to document that the installation is in general accordance with the Technical Specifications.

Deployment - Verify that only approved materials are used, that each panel is given a unique panel number, geomembrane is not placed during inclement or other unsuitable weather conditions, the geomembrane is not damaged during installation, and anchoring is performed in accordance with the Technical Specifications and Contract Drawings. Record the deployment on the geosynthetic data sheets.

Trial Seams - Verify that seaming conditions are adequate, tests are performed at required intervals, specified test procedures are followed, and that retests are performed in accordance with the Technical Specifications. The Geosynthetics Installer will perform pre-weld testing (trial seaming) at the beginning of each crew shift and immediately following any work stoppage of 30 minutes or more or changes in seaming process. Seaming operations will not commence until the CQA Consultant has determined that the seaming process is meeting the specification requirements and is acceptable. Visual observation is required on the trial seam by the CQA Consultant. The trial seam will be a minimum of 10 feet for self-propelled seaming devices and a minimum of 3 feet for hand-held seaming devices. The CQA Consultant will mark the test weld with date, ambient temperature, welding machine number, welding technician initials, machine temperature, and speed. For extrusion welding, the CQA Consultant will record the nozzle and extrusion settings. The trial seam sample will be archived by the CQA Consultant at the Site. The CQA Consultant will record the trial seam test results on the geosynthetics data sheets.

In addition, shear and peel adhesion tests will be conducted on 1-inch wide specimens of the trial seams at the Site. A minimum of three specimens will be tested for shear and for peel adhesion. All specimens must be acceptable; otherwise, the trial seams will be repeated until all specimens from a given trial seam are acceptable.

Field Seaming - Verify that only approved equipment and personnel perform welding, all welding is performed under suitable conditions as specified in the specifications, specified overlaps are achieved, seams are oriented in accordance with project requirements, and that grinding techniques and extrudate meet project requirements for extrusion welding. The CQA Consultant will record pertinent information on geosynthetic data sheets.

Non-Destructive Seam Continuity Testing - Verify that all seam lengths are non-destructively tested by the Contractor in accordance with the Technical Specifications. If the seam cannot be tested, the CQA Consultant will observe cover system strip

operations and verify that test equipment and gauges are functioning properly and that test procedures are in accordance with the project requirements. The CQA Consultant will verify that all failing seam lengths are repaired and re-tested until passing results are achieved. The CQA Consultant will record all non-destructive test locations on geosynthetic data sheets.

Destructive Seam Testing - The Contractor's Geosynthetic Installer will furnish destructive testing samples of the field-seamed geomembrane in accordance with the Technical Specifications, at locations selected by the CQA Consultant. The samples will be taken and prioritized as follows:

- all areas identified as suspect during seaming or non-destructive testing/monitoring;
- a minimum of one sample for each geomembrane seamer per day;
- a minimum of one sample for each representative working conditions (e.g., weather conditions); and
- a minimum of one sample for every 500 feet of seaming.

Each destructive sample will, at a minimum, measure 12 inches by 48 inches in length with the seam centered lengthwise. Two specimens, one from each end of the sample, will be cut and tested for peel and shear strength in the field by the Contractor using a calibrated field tensiometer cover system able of quantitatively measuring peel and shear strengths, in accordance with the Technical Specifications. The CQA Consultant will record the test results on the geosynthetic data sheets.

A total of four (4) samples will be collected. One sample will be tested in the field and the other three samples will be distributed as specified below. If the specimen tested in the field fails, the Geosynthetic Installer will provide additional test samples 10 feet from the point of the failed test in each direction for repeat of the field test procedure. If these additional tests fail, then the procedure will be repeated until the length of the failed seam is established. Once the field tests have passed, the remainder of the sample will be divided into three equal sections and distributed as follows:

- one sample to the CQA Consultant's Geosynthetic Laboratory for testing;
- one sample to the Construction Manager for its records; and
- one sample for Site Archives.

Each sample will be subjected to the following tests:

- Seam shear strength (five specimens) - ASTM D3083; and
- Seam peel strength (five specimens) - ASTM D413.

A minimum of five of the five samples for shear and four out of five for peel in accordance with current Alabama regulation must meet the minimum field seam properties listed in the Technical Specifications. Both tracks of a double-track fusion weld will be destructively tested for peel and one track tested for shear.

Failing laboratory tests will be subject to additional testing until a passing sample is found. The Geosynthetic Installer will take another destructive sample 10 feet from the point of the failed test in each direction and the field test procedure will be repeated. If

subsequent tests fail, then the procedure is repeated until the length of the failed seam is established. Once the field tests have passed, a second sample will be taken between the passing specimens and tested by the CQA Geosynthetic Laboratory. Failed seams will be tracked according to the welding apparatus and the machine operator. Samples taken as the results of failed tests will not be counted toward the total number of destructive tests required. All failed field seams must be documented to be bounded on both sides by passing destructive tests. Laboratory destructive testing results will govern the acceptability of seams; if either laboratory reports a failed result, then the sample will be considered as failing.

The Geosynthetics Installer shall be responsible for patching all areas cut for test samples and for non-destructive testing (e.g. vacuum box, etc.) in accordance with the Technical Specifications. The CQA Consultant will record all test locations, results, actions taken in conjunction with destructive test failures, and repairs.

Repairs - Observe and document that all materials, techniques, and procedures used for repairs are approved in advance. The CQA Consultant will verify that all repairs are marked, recorded, repaired, tested, and that wrinkles are addressed, prior to being covered by other materials. The CQA Consultant will record defects and repairs on the geosynthetic data sheets.

4.2.4 Geotextile and Geosynthetic Drainage Strip Monitoring

During geotextile and geosynthetic drainage layer installation, the CQA Consultant will observe and document on geosynthetic data sheets the Contractor's deployment, field seaming, and repairs to help evaluate whether the Contractor's installation is in accordance with the Technical Specifications.

Deployment - The Contractor will verify that the underlying layers are clean and free of deleterious materials prior to deployment, anchoring is achieved as specified, methods are used to minimize wrinkles, and underlying layers are protected during cutting of materials.

Seams - The Contractor will verify sufficient overlap and/or that the specified seam procedures are followed as required in the Technical Specifications. The Contractor will verify that horizontal seams are positioned at least 5 feet from the top and/or toe of all slopes steeper than 10 percent unless approved by the CQA Consultant.

Repairs - The Contractor will verify, as observed by the CQA Consultant, that all repairs are performed in accordance with project specifications.

Protection - Geotextiles shall be covered within 15 days following placement. The Contractor will place materials in a manner to prevent damage to the geosynthetics and underlying materials. The Contractor will conduct his operations so that a minimum thickness of soil separates the geosynthetics from the tracks or wheels of construction equipment (depending on contact pressures), minimal slippage of the geosynthetics occurs on the underlying materials and that no excess tensile stresses occur in the

geosynthetics. Except where noted in the Contract Documents, no traffic shall be allowed on geosynthetics without at least 3 feet of cover, unless low ground pressure equipment (5 psi) is used which may be allowed with a minimum of 9 inches of cover soil. An example exception would be where a woven geotextile underlies gravel access roads.

4.3 Gravel Toe Drain

The CQA Consultant will observe the Contractor's installation of the toe drain, including:

- Start and completion dates;
- Spot checking the drain for conformance to the lines and grades presented on the Contract Drawings;

Any significant deviation from the Technical Specifications, Drawings, or manufacturer guidelines will be brought to the immediate attention of the Contractor and Construction Manager.

5.0 RECORDS AND REPORTING

5.1 Contract Drawings

The Contractor and Construction Manager will each maintain on the Site one unmarked set of the Drawings, CMI Work Plan, Technical Specifications, and other reports pertinent to the construction, along with a record of all proposed, pending, and approved changes and clarifications to the Contract Documents. The Contractor will also maintain at all times one set of marked-up Record Drawings indicating progress of construction.

5.2 Contract Submittals

Submittals required by this CQAP and the Technical Specifications will be logged in at the time of receipt by the Construction Manager. A record of the submittal and review form indicating favorable review or rejection of the submittal will be kept on file at the office of the Construction Manager. A copy indicating the final status will be returned to the Contractor for its files.

5.3 Daily Records

The CQA Consultant will keep records of construction and testing activities, which, in conjunction with the Contractor's submitted manuals and as-built drawings, will enable preparation of Record Drawings and the Construction Completion Report.

Daily Summary Reports will be numbered sequentially and will include at least the following:

1. Date and project name;
2. Weather conditions, including daily high and low temperature, wind conditions, and precipitation;
3. General description of work activities at the Site;
4. List of personnel and equipment operating on-site, number of hours worked, number of hours on standby, and work activities completed;
5. Description of work completed for the day, referencing stationing and grid coordinates as appropriate;
6. Identification of areas worked including lift number, panel number, and/or seam number;
7. Reduced-scale drawings or sketches showing work completed;
8. Summary of test samples taken, with locations and elevations as appropriate;

9. Summary of test results compared with Specification requirements and indication of pass or fail status for the samples;
10. Test equipment calibrations, unless recorded in other field notebooks;
11. List of off-site materials received;
12. Summary of QA and QC procedures used for the day and list of CQA personnel on-site;
13. Problems encountered and resolutions reached; and
14. Health and Safety issues and their resolution.

5.4 Construction Problem and Corrective Measure Reports

A problem is defined herein as material or workmanship that apparently does not meet the requirements of the Contract Documents. Construction Problem and Corrective Measures Reports will be cross-referenced to specific monitoring and testing data sheets where the problem was identified. Construction Problem and Corrective Measures Reports shall be numbered sequentially and include the following information:

1. Detailed description of the problem;
2. Location and probable cause of the problem;
3. How and when the situation was identified;
4. How the problem was corrected or resolved;
5. Any measures taken to prevent similar problems in the future; and
6. Signatures of the CQA Consultant, Construction Manager, and Contractor's Project Manger.

5.5 Photographic Records

The Construction Manager will take color and/or digital photographs.

5.6 Final Documentation Report

Within 90 days of completion of construction, the CQA Consultant and Construction Manager will complete the Construction Completion Report for the project. The report will state that, based on observation of the Contractor's work and on evaluation of furnished test results and other

information, the Contractor's work has been completed in general conformance with the Contract Documents, with any significant exceptions noted. The report will include the following:

1. Narrative description of construction activities completed at the Site and copies of all Daily Summary Reports;
2. Description of material deviations from Contract Document requirements and justification for such changes;
3. Description of CQA testing procedures;
4. Summary of CQA test data including copies of all soil and geosynthetics monitoring and test data sheets;
5. Descriptions of procedures used by the Contractor to rework or repair areas with failing CQA test results;
6. Color photographs of major project features;
7. As-built plans and details of the completed construction, prepared by the Contractor; and
8. Certification statement by the CQA Consultant of completion of construction in accordance with the Contract Documents.

5.7 Records Storage

Throughout the construction, all original documents or copies will be kept in a secure and fireproof organized file on-Site. All records and documents relating to the cover system will be preserved and retained by Solutia.

5.8 Plan Modification Procedure

Should this CQAP require major modification, the proposed changes will be submitted in writing to the Designer and Construction Manager for review. If the proposed major modification is deemed to be appropriate, a letter requesting approval of the change will be submitted to the ADEM. The text will be changed in the form of an addendum and will be attached to all copies of the CQAP following receipt of approval from ADEM.

Appendix E - Best Management Practices Plan



**BEST MANAGEMENT PRACTICES PLAN
CHOCOLOCCO CREEK
WASTEWATER TREATMENT PLANT PROJECT
ANNISTON, ALABAMA**

JANUARY 2003

Submitted to:

Solutia Inc.
702 Clydesdale Avenue
Anniston, Alabama 36201-5390

Prepared by:

Golder Associates Inc.
3730 Chamblee Tucker Road
Atlanta, Georgia 30341



Jan. 16, 2003

TABLE OF CONTENTS

Table of Contents	i
-------------------------	---

<u>SECTION</u>	<u>PAGE</u>
1.0 INTRODUCTION	1
1.1 Background.....	1
1.2 NPDES Permit Authority	2
1.2.1 Plans Required Under NPDES	2
1.3 Purpose	2
1.4 Scope of Work.....	3
1.5 Approach and Overview.....	3
1.6 Mechanisms for Plan Revisions	4
1.7 Management Approval.....	4
2.0 SITE DESCRIPTION	6
2.1 Site Location and Description	6
2.2 Project Stormwater Flow Rates.....	6
3.0 BEST MANAGEMENT PRACTICES.....	7
3.1 Good Housekeeping	8
3.2 Maintenance/Inspection Procedures.....	8
3.3 Employee Training	9
3.4 Record Keeping and Internal Reporting Procedures.....	10
3.4.1 Record Keeping.....	10
3.4.2 Reporting	10
3.5 Discharge Monitoring, Inspection, and Reporting Requirements.....	11
4.0 SITE STORMWATER MANAGEMENT CONTROLS.....	12
4.1 General Considerations	12
4.2 Cleaning Of Stormwater Control Devices.....	12
4.3 Sedimentation Prevention.....	12
4.4 Conversion to Permanent Control	12
5.0 SITE EROSION AND SEDIMENTATION CONTROLS	13
5.1 Overview	13
5.2 Description of General Erosion and Sedimentation Controls.....	13
5.2.1 Stabilization Practices	13
5.2.2 Structural Practices.....	14
5.3 Construction-Specific Controls	15
5.3.1 Temporary Stream Crossing.....	16
5.3.2 Off-Site Vehicle Tracking.....	16
5.3.3 Grading and Restoration of Disturbed Areas	16
6.0 REFERENCES	18

In Order
Following
Page 18

FIGURES

- FIGURE 1 Site Location Map
- FIGURE 2 Erosion and Sediment Control Plan
- FIGURE 3 Erosion and Sediment Control Details

ATTACHMENTS

- ATTACHMENT A Construction General Permit (GP) Notice of Intent (NOI) Package, Parts I-III
- ATTACHMENT B Certification Sheet
- ATTACHMENT C Release Report Forms
- ATTACHMENT D Inspection and Maintenance Report Form
- ATTACHMENT E NPDES Permit Monitoring Report Forms

1.0 INTRODUCTION

1.1 Background

The Choccolocco Creek Wastewater Treatment Plant (WWTP) is located within the incorporated limits of the City of Oxford, Alabama, on a property bound on the north by Interstate I-20 and on the south by Choccolocco Creek. The property contains approximately 49 acres and is transected by Snow Creek. The WWTP facilities lie on 33 acres of this tract located to the west of Snow Creek. Figure 1 provides a Site Location Map.

The Anniston Water Works and Sewer Board (Board) is conducting a plant expansion to increase the capacity of the WWTP. The expansion includes the construction of three retention ponds; a headwork's building; an odor control scrubber unit; two grit basins; a new maintenance building; a peak flow pump station; a groundwater pumping station; and associated piping, force mains, and wash down pipes. As a result of the expansion, approximately 60,000 cubic yards of soil excavated from two of the three proposed ponds were transported and deposited in a stockpile across (east of) Snow Creek. The stockpile is irregular in shape and covers about 5 acres of the property. A large portion of the stockpile is located along the bank of Snow Creek, where it averages six (6) to eight (8) feet in height. A number of smaller piles, three (3) to five (5) feet high, lie further east of the creek's bank. The smaller piles were apparently the result of unloading trucks of material brought from the excavations across the creek. These small piles were not consolidated into the larger pile. The stockpiled soil is currently covered with polyethylene sheeting to reduce erosion. The stockpile is also covered with a substantial amount of vegetation.

Analytical testing of soil obtained from the stockpile indicates that the soil contains polychlorinated biphenyls (PCBs), mostly in concentrations less than 50 milligrams per kilogram (mg/kg). Construction activities related to the expansion of the WWTP were suspended by ADEM, due to National Pollutant Discharge Elimination System (NPDES) violations, before construction of Pond No. 3 began. Most of Pond No. 1, as well as Pond Nos. 2 and 3 in their entirety, lie within the 100-year floodplain of Snow Creek. Snow Creek and its floodplain are within the Area of Concern B under the RCRA Facility Investigation currently being undertaken by Solutia, and, therefore, ADEM requested that Solutia participate in the evaluation and implementation of corrective measures designed to manage the stockpile. Solutia prepared and submitted to ADEM a corrective measures study (CMS) presenting three alternatives for managing the soils stockpiled on the east bank of Snow Creek. As stated above, ADEM approved "Alternative No. 3", and requested Solutia to submit a Work Plan detailing the corrective

action outlined in the CMS. This plan has been prepared to address Erosion and Sediment Control Measures during the implementation of the proposed corrective measures.

1.2 NPDES Permit Authority

1.2.1 Plans Required Under NPDES

The National Pollutant Discharge Elimination System (NPDES) is a national program for issuing, modeling, revoking, etc. permits under Sections 307, 318, 402, and 405 of the Clean Water Act of 1990. Under this program, the state of Alabama is authorized to implement a state run program. This program requires that the Owner of a facility submit a Notice of Intent (NOI) when five (5) or more acres of land are disturbed through construction activities. In addition, the Owner is required to develop a "**Best Management Practice Plan**" (BMP Plan) and, if applicable, a "**Spill Prevention, Control, and Countermeasures Plan**" (SPCC Plan). These plans should be fully developed and implemented upon submitting the NOI.

The NPDES General Permit requires Solutia to prepare and implement a BMP Plan describing practices to prevent/minimize the discharge of all sources of pollution in storm water runoff to State waters. The BMP Plan should detail the structural and non-structural practices that will be implemented and maintained to prevent/minimize the discharge of all sources of pollution (i.e., sediment, trash, garbage, debris, oil & grease, chemicals materials, etc.) to State waters in storm water run-off. This plan should address applicable BMPs as provided in the Alabama Non-Point Source Management Program Document and the United States Environmental Protection Agency (USEPA) Stormwater Pollution Prevention for Construction Activities document.

The NPDES General Permit also requires Solutia to prepare, implement, and maintain a SPCC Plan for all on-site fuel or chemical storage tanks if the volume requirements are met. The SPCC Plan has been prepared and is provided as a separate document. The SPCC Plan contains the overall measures that will be undertaken to prevent and control possible releases of pollutants.

1.3 Purpose

The purpose of this BMP Plan is to detail the storm water management and erosion and sedimentation controls that will be implemented to prevent/minimize the discharge of all sources of pollution to State

waters in surface water runoff during the construction activities at the Choccolocco Creek Wastewater Treatment Plant project site.

1.4 Scope of Work

The principal elements of work associated with this BMP Plan are listed below:

- establishment of temporary stream crossing, entrance and roads;
- general preparations of the work area;
- installation of erosion control structures;
- construction of a vehicle decontamination pad at the site;
- consolidation and relocation of PCB-containing soil;
- construction of the multi-layer cover over PCB-containing soil;
- equipment decontamination and disposal; and
- post-construction cleanup and seeding.

1.5 Approach and Overview

The BMP Plan for the WWTP project was developed using USEPA and ADEM guidance documents and engineering judgment. The erosion and sedimentation control practices identified in this plan are intended to be supportive of the storm water management practices. The storm water management practices provide planning such that runoff from the site will be safely conveyed to stable outlets using a variety of storm drains, diversions, and stable waterways. These storm water management practices provide for installation of storm water retention structures to prevent flooding and damage to downstream facilities resulting from runoff from the site. To assure that the site construction activity includes limiting erosion and sedimentation, this BMP Plan has been employed to implement the following five guidance items:

1. Minimize Land Disturbance. To the extent possible and practical, construction-disturbed areas and the duration of exposure to erosion elements will be minimized. Cleaning of natural vegetation will be limited to only those areas of the site to be developed at a given time. To the extent possible and practical, natural vegetation will be retained and protected.
2. Forward Planning. Planning for construction activity will consider site topography and soils, and the potential effects on erosion and sedimentation. Areas of steep, erodable slopes and erodable soils will not be disturbed without instituting proper engineering controls to minimize these concerns.
3. Stabilization of Disturbed Areas. Construction-disturbed areas will be stabilized as soon as is practicable. Temporary or permanent vegetation, and mulch, or a combination of these measures, will be employed as quickly as possible and practical

after the land is disturbed. Temporary vegetation and mulches may be used on areas where it is not practical to establish permanent vegetation. These temporary measures will be employed immediately after rough grading is completed if a delay is anticipated in developing finished grade.

4. Sediment Capture. Sediment barriers and related structures will be installed to filter or trap sediment on the site. It is recognized, however, that the most effective method of controlling sediment is to control erosion at its source. Sedimentation retention structures will be placed to retain sediment when erosion control methods are not practical, or have failed due to some unforeseen factor.
5. Decrease Peak Storm Velocities. It is expected that storm water runoff velocity will increase for a short period due to the removal of vegetation during construction. Sediment barriers will be installed during construction to slow the runoff traveling through the construction site.

1.6 Mechanisms for Plan Revisions

The BMP Plan and all accompanying records, reports, and changes will be retained for the duration of the project plus three (3) years. This BMP Plan will be reviewed and amended, at a minimum, when the following occurs:

- applicable ADEM or federal regulations are revised;
- the NPDES General Permit for the construction site is revised;
- the BMP Plan fails in an emergency or does not comply with the NPDES General Permit involving storm water and construction activities (a copy of the permit is contained in Attachment A);
- there is a change in discharge design, operation, maintenance, or other circumstances, that materially increases the potential for sediment or erosion on the site; or that changes the response necessary, in an emergency; and/or
- as may otherwise be required by ADEM.

1.7 Management Approval

USEPA and the State of Alabama require that the "**Best Management Practice Plan**" be signed by an authorized person. A copy of the certification letter is included in Attachment B.

The BMP Plan will be retained on-site at the project offices and/or on-site trailers and will be available to members of ADEM upon request, or, in the case of an unplanned storm water discharge from the site associated with the construction activity. ADEM, or an authorized representative upon the presentation of credentials and other documents as may be required by law, will be allowed to:

- enter upon the premises of the site and have access to the records that must be kept under the conditions of this plan;
- be able to copy at reasonable times, any records that must be kept under the condition of this plan; and/or
- inspect at reasonable times any facilities, equipment, or structures.

2.0 SITE DESCRIPTION

2.1 Site Location and Description

The WWTP project is located within the City of Oxford, in northeastern Alabama, just south of Interstate 20. It is bounded on the west by Snow Creek, on the north by I-20, on the east by vacant woodland and residential areas, and on the south by Choccolocco Creek.

The site was originally flat with a slight slope towards the southwest where storm water runoff flows toward Choccolocco Creek.

2.2 Project Stormwater Flow Rates

A hydrology study was not performed for this site. However, because the soils are well drained and permit moderate infiltration and the site is relatively flat, excessive runoff rates are not expected when moderate to large rainfall events occur during construction. All storm water runoff will enter Choccolocco Creek via sheet flow. Note that prior to flowing into the creek, runoff will pass through a series of erosion and sediment controls.

3.0 BEST MANAGEMENT PRACTICES

The most effective method to prevent pollution of surface water is to implement Best Management Practices (BMPs). BMPs are schedules of activities, prohibitions of practices, maintenance procedures, and other management practices to prevent or reduce pollution of waters. BMPs include treatment requirements, operation procedures, and practices to control site runoff.

BMPs typically are divided into two levels: baseline and advanced. Baseline BMPs are general practices that apply to most industrial sites, independent of the types of materials used, processes employed, products manufactured, or site location. Baseline BMPs are relatively simple, inexpensive, and cost-effective practices that emphasize prevention of pollution rather than treatment of pollutants. Advanced BMPs may be required where baseline BMPs do not provide adequate control of storm water pollution sources. The need for advanced BMPs is not anticipated for this project.

The USEPA has defined seven baseline BMPs to limit and control sediment and erosion. These baseline BMPs will be employed at the WWTP project Site. The seven baseline BMPs are listed below.

- Leave as much vegetation (plants) on-site as possible;
- Minimize the time that soil is exposed;
- Prevent the runoff from flowing across disturbed areas (divert the flow to vegetated areas);
- Stabilize disturbed soils as soon as possible;
- Slow down the runoff flowing across the site;
- Provide drainage ways for the increased runoff (e.g. use existing grassy swales); and
- Remove sediment from storm water runoff before it leaves the site.

Selecting the best set of sediment and erosion prevention measures for the site depends upon the construction activities and other site-specific conditions (soil type, topography, climate, and season). Erosion can be controlled by stabilizing the site and/or by installation of structural methods of control. The incremental steps used to complete the project will be to install any necessary baseline BMPs before starting any construction activities and then apply advanced BMPs if the baseline BMPs do not sufficiently prevent erosion and sedimentation from the construction site. Erosion control measures will be installed based on the surrounding construction activity, so appropriate measures are used in each area of the site.

In addition to using baseline BMPs, good housekeeping measures, maintenance/inspection procedures, employee training, record keeping and internal reporting procedures, and inspection and reporting requirements will be used during this construction project.

3.1 Good Housekeeping

Good housekeeping is important on any construction project to minimize accidents and to ensure high quality work. The Contractor at the site has full responsibility and accountability for meeting good housekeeping requirements.

The "good housekeeping" practices listed below will be followed during the Project.

- All erosion and sediment control measures will be kept in place, will be adequate for the erosion/sediment control of concern, and will be properly constructed and maintained;
- Clearing operations will be confined within the limits shown on the plans;
- The vegetation outside of the clearing area will be protected by not traveling into those areas;
- Controls will be installed such that sediment transported from the site onto public rights-of-way by vehicular traffic will be minimized;
- The sediment barriers and related devices will be those which are effective in retaining sediment on the site;
- The appropriate vegetation will be established as needed on all specified areas, this includes temporary vegetation;
- Work progress will be in accordance with the proposed schedule;
- The contractor will follow the plan and construction sequence;
- As may be necessary, temporary stream channel crossings will be installed and maintained;
- No severe fire hazards will exist that could result in brush or grass fires;
- There will be no excessive sediment leaving the site for any reason;
- All materials stored on-site will be stored in a neat, orderly manner in their appropriate containers and, if possible, under a roof or other enclosure;
- Information sessions on good housekeeping practices will be incorporated into the employee meetings; and
- Bulletin boards, with updated good housekeeping procedures, tips, and reminders will be posted for field personnel.

3.2 Maintenance/Inspection Procedures

The following inspection and maintenance practices will be used to maintain erosion and sediment controls on-site during construction activities.

- All control measures will be inspected a minimum of twice a month with monthly inspections a minimum of two weeks apart.

- All control measures will be inspected within 72 hours after any precipitation of 0.75 inches or greater in any 24-hour period since the last inspection.
- Areas that have been finally stabilized will have an inspection of all control measures at least once every month.
- All measures will be maintained in good working order; if a repair is necessary, it will be initiated within 24 hours of report.
- Silt fence will be inspected for depth of sediment, tears, to see if the fabric is securely attached to the fence posts, and to see that the fence posts are firmly in the ground.
- Any constructed sedimentation trap will be inspected for depth of sediment, and built-up sediment will be removed when it reaches one half of the design depth. Sedimentation control structures will be inspected for erosion, piping, and risk of displacement after each significant rainstorm (0.75 inch or greater), and will be repaired immediately.
- Diversion and containment dikes will be inspected and any breaches promptly repaired.
- Temporary and permanent seeding and planting will be inspected periodically by the Contractor for bare spots, washouts, and healthy growth. These spots will be repaired as necessary.
- Maintenance inspection reports will be kept using forms found in Attachments C-E.
- The Contractor will select individuals, with the approval of the Construction Manager, who will be responsible for inspections, maintenance and repair activities, and filling out the inspection and maintenance report.
- Personnel selected for inspection and maintenance responsibilities will receive training. They will be trained in all the inspection and maintenance practices necessary for keeping the erosion and sediment controls used on-site in good working order. (The Construction Manager or the Project Engineer will train these persons.)

All monitoring forms will be maintained onsite, and copies of these forms will be forwarded to ADEM on a yearly basis.

3.3 Employee Training

An effective training and education effort for all site personnel will be maintained. The Construction Manager or the Project Engineer will hold the training sessions. The program will address the following:

- briefings to all field personnel regarding the scope and importance of erosion and sedimentation control; and
- training for the personnel authorized to perform the inspections and administrative duties of the erosion and sediment control program.

The briefings to all employees will address the following areas:

- sedimentation and erosion prevention - a review of the purposes and goal of the BMP Plan, potential sources of sediment and erosion at the site, BMPs employed at the site, and the role the field personnel fill in sediment and erosion prevention,
- pollution control laws and regulations pertaining to sediment release; and

- the high priority all Contractors and Solutia give to sedimentation and erosion prevention on this project.

3.4 Record Keeping and Internal Reporting Procedures

3.4.1 Record Keeping

Maintaining records for all inspections is an important element of the BMP Plan. Documentation of all inspections, whether routine or detailed, will be viewed as a good preventive maintenance technique. Analysis of inspection records allows for early detection of any potential problems.

Keeping a log of all maintenance activities, such as the cleaning of catch basins or repairing erosion on a berm or dike, will enable the effectiveness of the BMP program, equipment, and operation to be evaluated. BMP Plan-related record keeping will be handled in conjunction with the SPCC Plan-related record keeping.

The following will be used to accurately document and report inspection results:

- field notebooks;
- daily reports;
- timed and dated photographs;
- video tapes; and
- drawing/sketches and maps.

All inspection forms will be maintained at the site in a separate three-ring binder in the Construction Manager's office. This book will be available for review by appropriate personnel upon request.

3.4.2 Reporting

Solutia will be provided copies of the weekly inspection of the storm water controls. These reports will be provided within one calendar week following each inspection. All other required forms and reports will be forwarded with the weekly reports.

Original records of inspections, and maintenance activities will be retained by the Construction Manager throughout the project. At the completion of the project, original records will be transferred to Solutia for safe keeping, with copies retained by the Contractor. Solutia should maintain the records for at least one year after coverage under the Facility NPDES Construction permit expires.

3.5 Discharge Monitoring, Inspection, and Reporting Requirements

The Alabama NPDES General Permit for construction requires certain monitoring, inspection, and record keeping. These requirements can be found in the NPDES General Permit under Part I (Attachment A). The Inspection Certification Form (Attachment B), as required, will be signed within 14 days of starting land disturbing activities authorized under the General Permit. The inspection and Maintenance Report Form to be filled out during the inspection are included in Attachment D, and includes items for rainfall events, structural control inspections, and other erosion control inspections. Other forms to be filled out include Release Report Forms (Attachment C) and other Monitoring Report Forms (i.e., Noncompliance Activities) (Attachment E). These forms will be completed and retained in the Construction Manager's Office.

These worksheets and report forms will be filed and submitted to ADEM as specified in the NPDES General Permit, Part I, Sections C and D (Attachment A). These forms shall be completed by the Owner or his designee and submitted to ADEM.

4.0 SITE STORMWATER MANAGEMENT CONTROLS

Site storm water controls used during the relocation and capping of the existing soil stockpile will be adopted at the Project site. All controls used will be designed and properly installed such that minimal sediment will enter Snow Creek or Choccolocco Creek.

4.1 General Considerations

The majority of the working area will be covered by vegetation at the end of construction. Therefore, the peak runoff will not increase significantly. Due to the small size of the proposed development, increases will be minimal and, therefore, no surface water control system has been designed. All flow will occur as sheet flow to Snow Creek or Choccolocco Creek similar to conditions existing prior to development.

4.2 Cleaning Of Stormwater Control Devices

All control devices must be cleaned of debris as needed to reliably convey the design storm water flow. This work must be completed in concert with other work discussed as a part of this task.

4.3 Sedimentation Prevention

Silt fence and hay bales will be installed around the perimeter of the existing stockpile area and along the banks of Snow Creek to prevent sediment from leaving the site. Controls will be centered on protecting this water body from receiving sediment via storm water runoff from the construction site. All removed sediments will either be incorporated under the proposed cover system or be directly loaded into roll-offs for management by Solutia.

4.4 Conversion to Permanent Control

The final task will be the conversion of storm water management to permanent controls. These tasks will be completed under the Project Engineer, Project Superintendent, and the Construction Manager judgments, such as, removing any sediment barriers left in place and providing permanent cover on areas that will no longer be disturbed.

5.0 SITE EROSION AND SEDIMENTATION CONTROLS

5.1 Overview

Two erosion and sedimentation controls will be implemented during the WWTP project. The first are the general controls that are implemented as needed when localized control is necessary. The second are the construction-specific controls that are implemented at locations of major site work. The general controls consist of both stabilization and structural practices and are defined in Section 5.2 in detail. The construction-specific controls applicable to the Project are summarized in Section 5.3.

5.2 Description of General Erosion and Sedimentation Controls

The USEPA defines two types of sediment and erosion control practices: stabilization practices and structural practices. Stabilization practices are those practices that preserve existing vegetation or revegetating disturbed soil as soon as possible after construction. Structural practices are used in sediment and erosion control to divert storm water flow away from exposed areas, convey runoff, prevent sediments from moving off-site, and can reduce the erosive forces of runoff waters. These controls are used as either permanent or temporary controls.

5.2.1 Stabilization Practices

Preserving existing vegetation or revegetating disturbed soil as soon as possible after construction is the most effective way to control erosion. A vegetative cover reduces erosion potential by shielding the soil surface from direct erosive impact of raindrops, by improving the water storage porosity of the soil, by slowing the rate of water run-off and by physically holding the soil in place with plant roots. Vegetative cover can be grass, trees, shrubs, bark, mulch, or straw. Grasses are the most common type of cover used for re-vegetation because they grow quickly.

Vegetative and other site stabilization practices can be either temporary (provide a cover for exposed or disturbed areas for short periods of time) or permanent controls. Stabilization measures will be initiated as soon as practicable in portions of the site where construction activities have temporarily or permanently ceased, but in no case more than 14 days after the construction activity in that portion of the site has temporarily or permanently ceased.

Vegetative-related erosion control practices, which will be utilized during the Project, are listed below.

- **Preservation of natural vegetation (grasses, brushes, vines and existing trees) -** A practical effort to preserve already stabilized areas and to provide natural buffer zones will be made.
- **Mulching (Ds1) -** Materials such as hay or straw will be placed as needed on the soil surface as a temporary soil stabilization measure during seeding activities. Straw mulch will be placed on all areas after seeding. On steep slopes, mulch matting may be used with netting or anchoring to hold the seed and soil in place, except in areas that receive soil.
- **Temporary seeding (Ds2) -** Growth of a short-term vegetative cover (plants) will be used on disturbed site areas that may be in danger of erosion. The temporary seeding will be applied no later than 14 days from the last construction activity in that area, ideally as soon as practical after the last land disturbing activity in an area. Hydro seeding is the preferred practice for temporary seeding. All temporary seeding will be completed in accordance with ADOT seeding recommendations.
- **Permanent seeding and planting (Ds3) -** Disturbed portions of the site where construction activities permanently cease will be stabilized with permanent, long-lived vegetative cover no later than 14 days after the last construction activity. Low-maintenance local plant species will be used. All other erosion control practices such as dikes, basins, and surface runoff control measures will be installed before planting. All permanent seeding will be completed in accordance with ADOT seeding and/or sodding.
- **Dust Control on Disturbed Areas (Du) -** Dust control on disturbed portions of the site where construction activities are ongoing will be in accordance with the separate Dust Control Plan (DCP) developed for this project.

The indicated code for describing each practice is in conformance with USEPA and ADEM guidelines.

5.2.2 Structural Practices

Structural controls can be used in sediment and erosion control in a variety of ways, for example:

- to divert storm water flows away from exposed areas;
- to convey runoff;
- to prevent sediments from moving off-site; and
- to reduce the erosive forces of runoff waters.

As implemented to support construction, the controls will be temporary measures. The structural controls that may be utilized during the Project include:

- **Channel Stabilization (Ch)**– Existing channels will be used to convey/divert water at the site. These channels may be stabilized if necessary to be non-erosive and provide adequate capacity for transferring water. As much vegetation as possible

will be left inside the channel right-of-way considering the requirements of construction, operation, and maintenance.

- **Construction Entrance/Exit (Co)**- Stone stabilized pads should be established at any point where traffic will be leaving a construction site to a public right-of-way, street, alley, sidewalk, or parking area. The purpose will be to reduce or eliminate the transport of mud from the construction area onto public rights-of-way by motor vehicles or by runoff.
- **Diversion (Di)**- Diversions will be utilized as necessary to reduce slope lengths, intercept storm runoff, and divert it to a stable outlet at a non-erosive velocity. Diversions will be developed as a ridge of compacted soil, constructed above, across, or below a slope.
- **Inceptor Dikes and Swales** - Ridges of compacted soil and excavated depressions, can be established to keep upslope runoff from crossing unprotected areas with a high risk of erosion.
- **Sedimentation Barrier - Filter Fence (Sd1)**- Also called a silt fence, this temporary sedimentation control measure consists of posts with filter fabric stretched across the posts. The lower edge of the fence is trenched in place and covered by backfill. The filter fence should be used with runoff velocities of 0.5 feet per second or less and will be placed perpendicular to the direction of flow. Silt fencing should be used on all side-slope and down-slope boundaries of the construction area. Silt fences should not be used in streams or swales. Silt fencing requires frequent inspection, especially after each rainfall. The sediment collected behind the fence will be removed and properly disposed when it is one-third to one-half the freestanding height of the fence.
- **Sedimentation Barrier - Straw Bale (Cd)**- Straw bales placed end to end (with no gaps in between) and staked into place can be used to prevent sediment from leaving the site by trapping the sediment in the barrier while allowing surface water to pass through. Installed perpendicular to the flow lines, straw bales can also be used to decrease the velocity of sheet flow or channel flows of low-to-moderate levels. The bales will be inspected and repaired immediately after each rainfall, or daily if there is prolonged rainfall. Damaged straw bales will be immediately replaced. Trapped sediments will be removed and properly disposed on a regular basis, or after each storm.

The indicated code for describing each practice is in conformance with USEPA and ADEM guidelines. Any deviations from the proposed measures must be approved by the Construction Manager.

5.3 Construction-Specific Controls

The construction-specific controls are discussed in the following sub sections.

5.3.1 Temporary Stream Crossing

The use of a bridge to cross Snow Creek for access during construction is the preferred method for temporary access to the west portion of the site. Normally, bridge construction causes the least disturbance to the creek bed and banks when compared to culverts. Most bridges can be quickly removed and reused. Additionally, construction, use, and/or removal of a temporary access bridge will not normally have any time of year restrictions, since construction, use, or removal will not affect the stream or its banks. Temporary bridges can be constructed from wood and logs, used railroad cars (flatcars and boxcars are usually 85 feet in length), truck flat beds (about 60 feet in length); portable hinged bridges, modular steel bridges (made of interlocking panels) and prestressed concrete panels (can often be purchased used from the DOT).

The stream crossings will include the following BMP's:

- the approach to the stream crossing will be made at a slope of 3% or less;
- the approach will be at right angles to the creek; and
- the approaches will be stabilized with rock extending at least 10 feet from both sides of the stream banks.

Detailed specifications for construction and maintenance of a temporary bridge crossing are included in the Technical Specifications for this project.

5.3.2 Off-Site Vehicle Tracking

A stabilized construction entrance will be provided to help reduce vehicle tracking of sediments off-site. All construction equipment entering work zones will stay within the designated zones until properly cleaned. Haul vehicles bringing in fill dirt will only be contacting soil areas already cleaned. At the conclusion of all work, construction equipment will again be thoroughly cleaned before leaving the site.

5.3.3 Grading and Restoration of Disturbed Areas

The soil stockpile will be graded and compacted in thin lifts. Immediately after the area has been completed to final grade, placement of the multi-layered cover system will commence. Sloped areas beyond the limits of the cover will be stabilized with grass. Therefore, the soil will be exposed for only a short time.

Additional erosion and sedimentation controls to be implemented during the Project include the following:

1. Cover. The temporary on-site stockpile of excavated soil will be covered daily with an impervious synthetic cover. During grading, silt fences will be placed around the stockpile. This material will ultimately be placed under the final cover system.
2. Monitoring Point. A storm water monitoring point will be established at the southern end of the property towards the creek to ensure that storm water runoff is not contaminated with sediment.

6.0 REFERENCES

Alabama Non Point Source Management Program Document, as amended, Alabama Department of Environmental Management, Water Division - Mining & Non Point Source Section, in accordance with Section 319 of the Federal Clean Water Act, as amended.

Stormwater Discharge Monitoring and Sampling Requirements NPDES General Permit ALG610000 - Construction and Other Land Disturbance Activity, Alabama Department of Environmental Management, Guidance Documentation, February 1, 1993.

Application Guidance for NPDES Permit for Stormwater Discharges from Construction, Excavation, Land Clearing, Other Land Disturbance Activities, and Associated Areas Not Authorized by an Existing NPDES Permit General Permit Number ALG610000, Alabama Department of Environmental Management, Mining & Non Point Source Section, MNPS Form 200-A, 8/1/92.

Stormwater Management for Construction Activities - Developing Pollution Prevention Plans and Best Management Practices, United States Environmental Protection Agency, Office of Water, 1993.

EPA Stormwater Pollution Prevention for Construction Activities, United States Environmental Protection Agency, Office of Wastewater Enforcement, and Compliance, as amended.

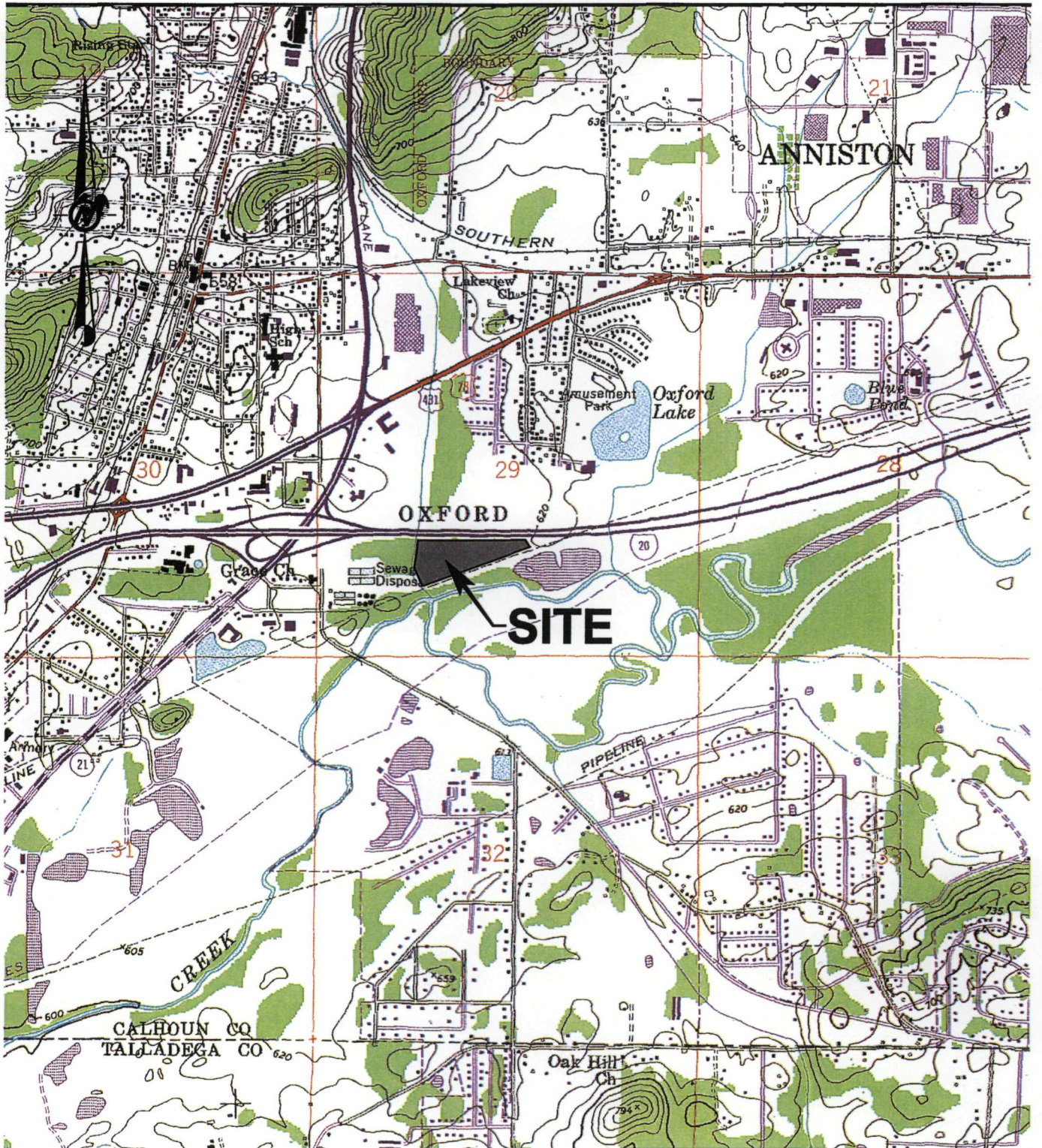

REF: USGS 7.5 MINUTE
OXFORD QUADRANGLE

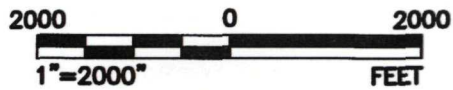

REV	DATE	DES	REVISION DESCRIPTION	CADD	CHK	RW
PROJECT						
SOLUTIA INCORPORATED CHOCOCCO CREEK WWTP ANNISTON, ALABAMA						
TITLE						
SITE LOCATION MAP						
PROJECT No. 934-3680			FILE No. 9433680WTPCHAR06			
DESIGN	-	-	SCALE	AS SHOWN	REV.	-
CADD	RMS	01/03	1			
CHECK						
REVIEW	SM					
 Golder Associates Atlanta, Georgia						

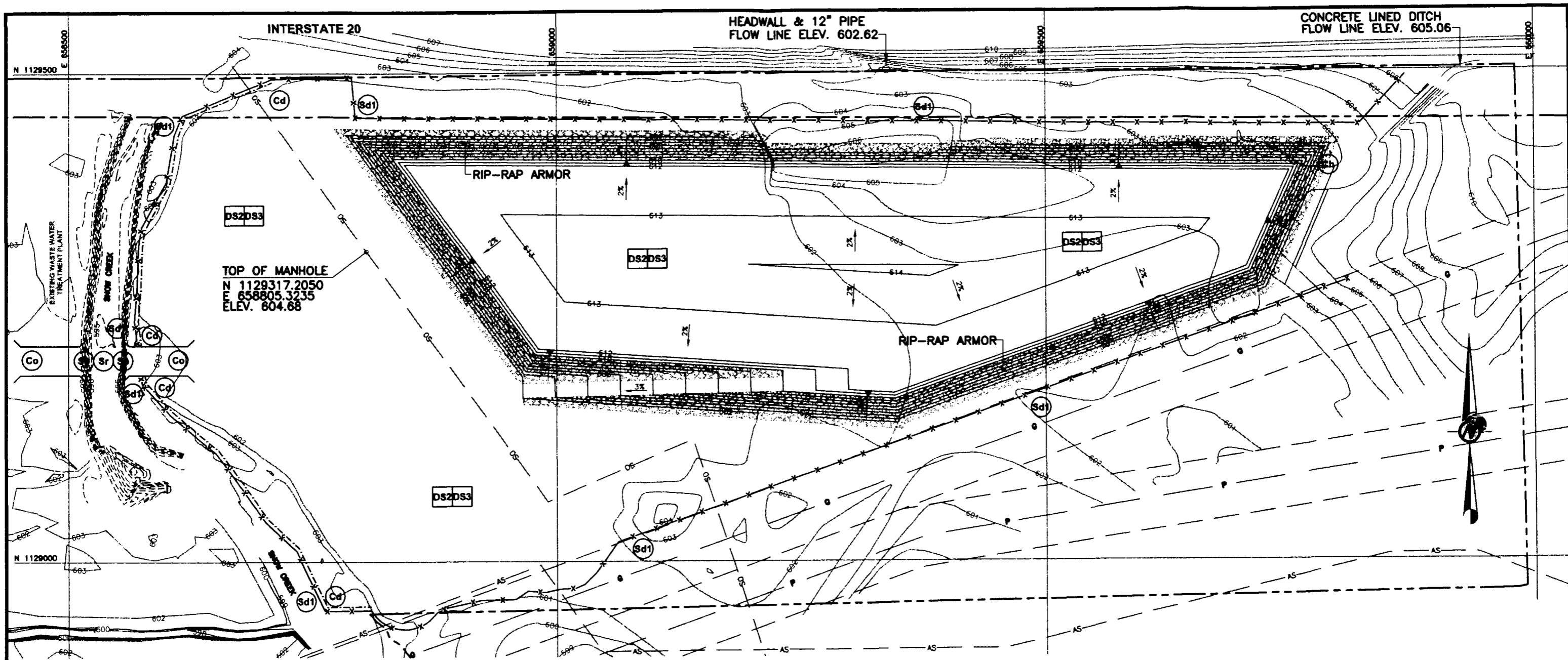

LEGEND

- PROPERTY BOUNDARY AND/OR RIGHT-OF-WAY
- 605 --- EXISTING CONTOURS
- 604 --- EXISTING CONTOURS
- G --- EXISTING GAS MAIN
- P --- EXISTING POWERLINE
- OS --- AS --- EXISTING SANITARY SEWER (SEE NOTE 3)
(OS-CITY OF OXFORD/
AS-CITY OF ANNISTON)
- 605 --- PROPOSED EARTH FILL CONTOURS
- 604 --- PROPOSED EARTH FILL CONTOURS

NOTES:

1. CONTRACTOR IS RESPONSIBLE FOR ALL APPLICABLE FEDERAL, STATE, AND LOCAL LAWS REGARDING EROSION AND SEDIMENTATION CONTROL.
2. AN NPDES PERMIT FROM THE ALABAMA DEPARTMENT OF ENVIRONMENTAL MANAGEMENT IS REQUIRED PRIOR TO COMMENCING CONSTRUCTION ACTIVITIES.
3. THE LOCATION OF THE OXFORD SANITARY SEWER LINE TO BE CONFIRMED PRIOR TO COMMENCING CONSTRUCTION ACTIVITIES.

REFERENCES:

1. EXISTING TOPOGRAPHY EAST OF SNOW CREEK PROVIDED BY MAXWELL SURVEYING, INC., DATED NOVEMBER, 2002.
2. EXISTING TOPOGRAPHY WITHIN SNOW CREEK AND WEST OF SNOW CREEK, PROPERTY BOUNDARY, EXISTING UTILITIES AND EASEMENTS PROVIDED BY KREBS ENGINEERING, INC.

EROSION & SEDIMENTATION CONTROL LEGEND

KEY	SYMBOL	DESCRIPTION
Co		CONSTRUCTION ENTRANCE
Cd		HAYBALE CHECK DAM
Ch		CHANNEL STABILIZATION (RIP-RAP)
Ds2		DISTURBED AREA STABILIZATION (TEMPORARY SEEDING/EXCEPT WHERE SLOPES ARE RIP-RAPPED)
Ds3		DISTURBED AREA STABILIZATION (PERMANENT SEEDING/EXCEPT WHERE SLOPES ARE RIP-RAPPED)
Sd1		SEDIMENT BARRIER (TYPE C SILT FENCE W/WOOD POST)
Sb		STREAMBANK STABILIZATION
Sr		TEMPORARY STREAM CROSSING (BRIDGE REQUIRED)

NOTE: FOR EROSION & SEDIMENTATION CONTROL DETAILS SEE FIGURE 3.



REV	DATE	DES	REVISION DESCRIPTION	CADD	CHK	R/W
PROJECT: SOLUTIA INCORPORATED CHOCOLOCCKO CREEK WWTP ANNISTON, ALABAMA						
TITLE: EROSION & SEDIMENT CONTROL PLAN						
PROJECT No. 943-3680		FILE No. FIG-02				
DESIGN	CMM	01/03	SCALE AS SHOWN	REV. -		
CADD	RMS	01/03				
CHECK	SJM	01/03				
REVIEW	SA					
			2			



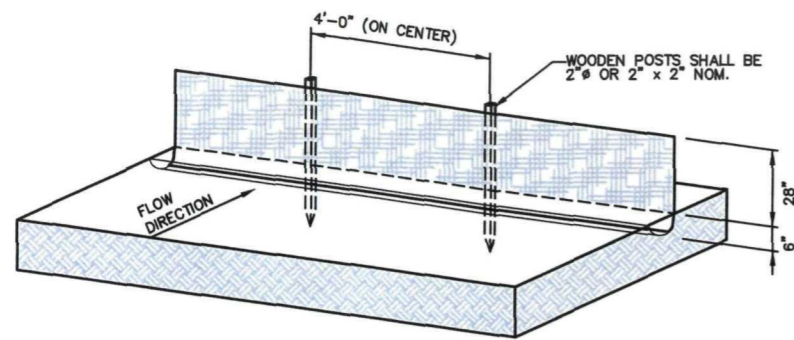

NOTES:

1. SILT CONTROL SHALL BE IN EFFECT PRIOR TO ANY GRADING OR CONSTRUCTION.
2. USE TYPE 'C' WIRE-REINFORCED SILT FENCE.
3. SPLICED JOINTS SHALL OVERLAP 18", WITH MATCHING POST.
4. DRIVE 4" (48") MIN. POSTS 12"-18" INTO SOIL.
5. DIG DITCH 12" WIDE, 6" DEEP. LAY FABRIC 6"-8" DEEP, THEN BACKFILL.

Sd₁ TYPE C SILT FENCE DETAIL
NTS

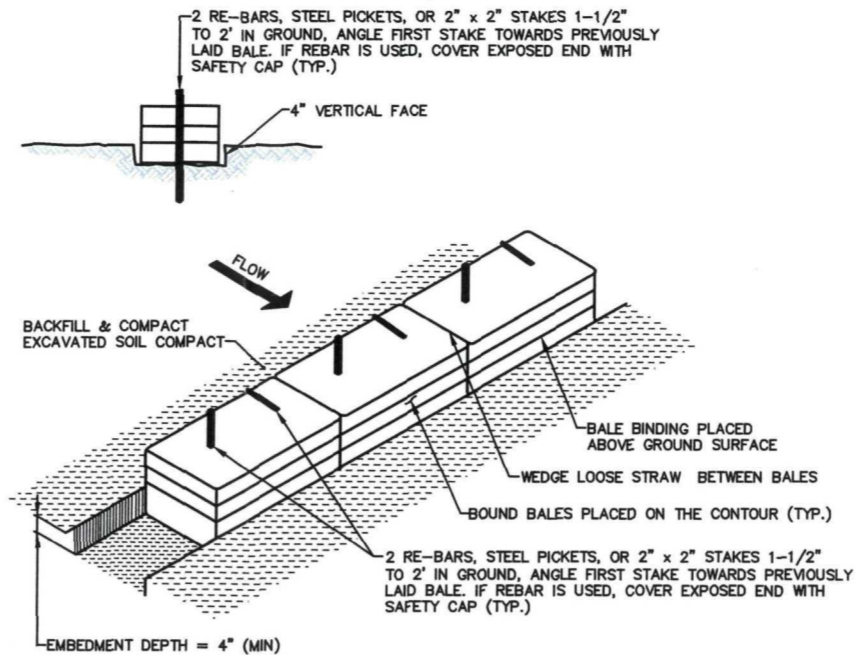

NOTE: PLACE HAY BALES STAKED AT STREAM CROSSING APPROACHES AS WELL AS PARALLEL TO THE LENGTH OF DISTURBED AREA ALONG THE BANKS OF SNOW CREEK TO CATCH SEDIMENT BEFORE IT ENTERS THE STREAM. LOCATE HAY BALES IN FRONT OF THE LINE OF SILT FENCES INSTALLED TO INTERCEPT AS MUCH SEDIMENT AS POSSIBLE. HAY BALES THAT BECOME FULL OF SEDIMENT SHOULD BE REMOVED AND PLACED AWAY FROM THE BANKS OF THE STREAM AND REPLACED WITH FRESH ONES.

Cd HAYBALE CHECK DAM
NTS

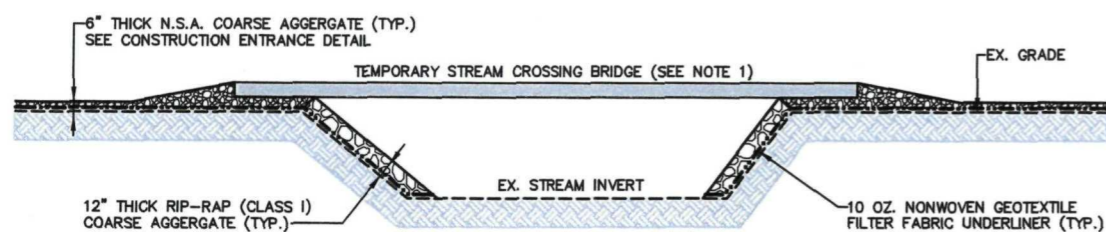

NOTE:

1. TEMPORARY BRIDGES CAN BE CONSTRUCTED FROM WOOD AND LOGS, USED RAILROAD CARS (FLATCARS AND BOXCARS ARE USUALLY 85 FT. IN LENGTH), TRUCK FLAT BEDS (ABOUT 60 FT. IN LENGTH), PORTABLE HINGED BRIDGES, MODULAR STEEL BRIDGES (MADE OF INTERLOCKING PANELS) AND PRESTRESSED CONCRETE PANELS (CAN OFTEN BE PURCHASED USED FROM THE DEPARTMENT OF TRANSPORTATION).

Sb STREAMBANK STABILIZATION
NTS

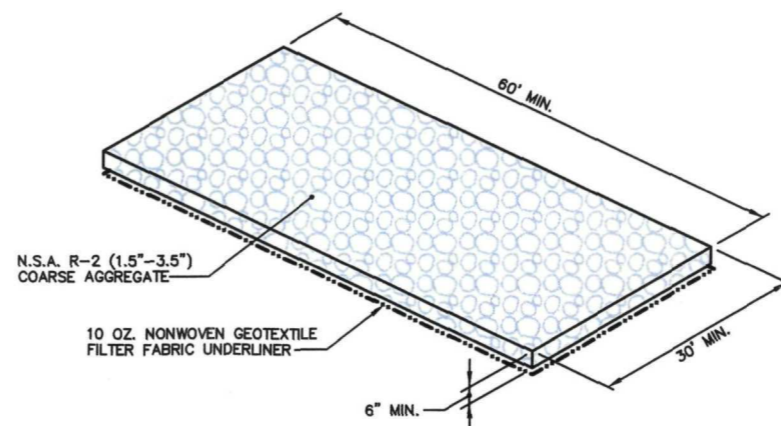

NOTE:

1. THE ENTRANCE/EXIT SHALL BE MAINTAINED IN A CONDITION WHICH WILL PREVENT TRACKING OR FLOW OF MUD ONTO PUBLIC RIGHT-OF-WAY. THIS MAY REQUIRE PERIODIC TOP DRESSING WITH 1.5-3.5 INCH STONE, AS CONDITIONS DEMAND, AND REPAIR AND/OR CLEANOUT OF ANY STRUCTURES TO TRAP SEDIMENT. ALL MATERIALS SPILLED, DROPPED, WASHED OR TRACKED FROM VEHICLES ONTO ROADWAYS OR INTO STORM DRAINS MUST BE REMOVED IMMEDIATELY. UPON COMPLETION OF CONSTRUCTION, STONE AND GEOTEXTILE WILL BE REMOVED.

Co CONSTRUCTION ENTRANCE/EXIT
NTS

GENERAL EROSION AND SEDIMENTATION CONTROL NOTES

1. EROSION AND SEDIMENT CONTROL SHALL BE AS PRESCRIBED IN THE APPROVED BMP AND THE TECHNICAL SPECIFICATIONS FOR THIS PROJECT.
2. THE INSTALLATION OF EROSION AND SEDIMENTATION CONTROL MEASURES AND PRACTICES SHALL OCCUR PRIOR TO OR CONCURRENT WITH LAND DISTURBING ACTIVITIES.
3. EROSION AND SEDIMENTATION CONTROL MEASURES SHALL BE MAINTAINED AT ALL TIMES. ADDITIONAL EROSION AND SEDIMENTATION CONTROL MEASURES AND PRACTICES SHALL BE INSTALLED IF DEEMED NECESSARY BY ON-SITE INSPECTION.
4. TEMPORARY GRASS WILL BE ESTABLISHED ON BARE SOIL WITHIN 14 DAYS OF BEING DISTURBED. ONCE THE CONSTRUCTION IS COMPLETE, PERMANENT GRASS WILL BE ESTABLISHED.
5. EROSION AND SEDIMENTATION CONTROLS SHALL NOT BE REMOVED UNTIL ALL CONSTRUCTION IS COMPLETE AND THE AREA STABILIZED.
6. MAINTENANCE OF ALL SOIL EROSION AND SEDIMENTATION CONTROL MEASURES AND PRACTICES, WHETHER TEMPORARY OR PERMANENT, SHALL BE AT ALL TIMES THE RESPONSIBILITY OF THE CONTRACTOR.

REV	DATE	DES	REVISION DESCRIPTION	CADD	CHK	R/W
PROJECT: SOLUTIA INCORPORATED CHOCOLOCCO CREEK WWTP ANNISTON, ALABAMA						
TITLE: EROSION & SEDIMENT CONTROL DETAILS						
PROJECT No. 943-3680		FILE No. FIG-03				
DESIGN	CMM	01/03	SCALE AS SHOWN	REV.	-	
CADD	RMS	01/03				
CHECK	SJM	01/03				
REVIEW	SM					
			3			



Drawing file: FIG-03.dwg Jan 13, 2003 - 3:31pm

ATTACHMENT A

Construction General Permit (GP) Notice of Intent (NOI) Package, Parts I-III

TO BE SUBMITTED UNDER SEPARATE COVER

ATTACHMENT B

Certification Sheet

**CHOCOLOCCO CREEK
WASTEWATER TREATMENT PLANT PROJECT
SOLUTIA INC., ANNISTON, ALABAMA
BEST MANAGEMENT PRACTICES PLAN**

January 2003

REVISION: 0

MANAGEMENT APPROVALS

“I certify under penalty of law that this document and all attachments were prepared under my direction of supervision in accordance with a system designed to assure that qualified personnel properly gathered and evaluated the information submitted. Based on my inquiry of the person or persons who manage the system, or those persons directly responsible for gathering the information, the information submitted is, to the best of my knowledge and belief, true, accurate, and complete. I am aware that there are significant penalties for submitting false information, including the possibility of fines and imprisonment for knowing violations.”

SOLUTIA INC.

Name (Type or Print)	Title
Signature	Date

CONTRACTOR APPROVALS

“I certify under penalty of law that I understand the terms and conditions of the general National Pollutant Discharge Elimination System (NPDES) permit that authorizes the storm water discharge associated with industrial activity from the construction site identified as part of this certification.”

CONTRACTOR: _____

Name (Type or Print)	Title
Signature	Date

ATTACHMENT C

Release Report Forms

**CHOCOLOCCO CREEK
WASTEWATER TREATMENT PLANT PROJECT**

CHEMICAL RELEASE REPORT FORM

(Sheet 1 of 1)

1. Date of Release: _____ 2. Approximate Time of Release: _____

3. Approximate Duration of Release: _____ 4. Quantities Released: _____

5a. Chemicals or Constituents Released: _____

5b. Release to (check media as appropriate): Air _____ Storm Drainage System: _____
Other Surface Water _____ Soil _____

6. Description of Incident (Location, Source, Cause)

7. Response Action Taken: _____

8. Corrective Measures Taken: _____

9. Anticipated Consequences of Incident (environmental, need for further corrective action, etc):

10. Verbal Report Filed: Time _____ Date: _____ By: _____

To: _____ of _____ (Agency or Organization)

**CHOCOLOCCO CREEK
WASTEWATER TREATMENT PLANT PROJECT**

ENVIRONMENTAL RELEASE REPORT FORM

(Sheet 1 of 2)

1. Inspection Team: _____ 2. Date: _____
_____ 3. Time: _____

4. Date of Last Inspection: _____ 5. Days Since Last Inspection: _____
6. Days Since Last Rain Event: _____ 7. Quantity of Last Rain: _____
8. Quantity of rain since Last Inspection: _____
9. Summary Inspection Checklist:

Item	Comments
1. Maintain containment of select soil	
2. Maintain soil and erosion control measures	
3. Maintain storm water conveyances	
4. Promptly clean up any minor fuel spills	
5. All vehicles cleaned as necessary before leaving the site or exclusion zones	
6. Promptly remove litter or debris	
7. Spill response equipment in place	

10. General Notes:

**CHOCOLOCCO CREEK
WASTEWATER TREATMENT PLANT PROJECT**

ENVIRONMENTAL RELEASE REPORT FORM

(Sheet 2 of 2)

11. Description and Volume of Observed Flows Into Stormwater Drainage System:

12. Comments: _____

13. Items for Corrective Action: _____

14. Date of Revision of Spill Prevention, Control, and Countermeasures Plan (SPCC):

15. Date of Implementation of Corrective Actions: _____

(use additional sheets as necessary)

ATTACHMENT D
INSPECTION AND MAINTENANCE REPORT FORM

**CHOCOLOCCO CREEK WASTE WATER TREATMENT PLANT
CONSTRUCTION OF SOIL CAP
INSPECTION AND MAINTENANCE REPORT**

Site Name: _____

Site location (City, County, State): _____

NPDES Permit Number: ALR _____

Weekly Rainfall Summary

Day	SUN	MON	TUE	WED	THU	FRI	SAT
Date							
Rainfall							

Sampling Information

Sample Type:

Location:

Analysis:

Inspection Results

Deficiencies or Required Maintenance:

Planned Corrective Action:

Corrective Action Schedule:

Other Comments:

Signature

Date

ATTACHMENT E

NPDES Permit Monitoring Report Forms

- Inspection Report and BMP Certification
- Non-compliance Notification Report

**ADEM - NPDES GENERAL PERMIT
ALG610000 AND ALG490000 INSPECTION REPORT AND BMP CERTIFICATION**

RESPOND WITH "N/A" AS APPROPRIATE. FORMS WITH INCOMPLETE OR INCORRECT ANSWERS, OR MISSING SIGNATURES WILL BE RETURNED AND MAY RESULT IN APPROPRIATE COMPLIANCE ACTION BY THE DEPARTMENT. IF SPACE IS INSUFFICIENT, CONTINUE ON AN ATTACHED SHEET(S) AS NECESSARY. PLEASE TYPE OR PRINT IN INK.

Company Name		Facility/Project Name	
Authorization ALR	County	Facility Contact and Title	
Facility Latitude & Longitude (deg,min,sec)		Facility Street Address or Location Description	
Township(s), Range(s), Section(s)		City	State Zip
Phone Number	Fax Number	E-Mail Address	

List name of current ultimate receiving water(s) (indicate if through MS4) and the number of disturbed acres which drain through each treatment system or BMP:

Receiving Water	Disturbed Acres	Receiving Water	Disturbed Acres
_____	_____	_____	_____

Appropriate Discharge and/or Instream Sampling Data Attached.

Based on this site evaluation which I or personnel under my direct supervision conducted, discharge, and/or instream sampling is not necessary to properly evaluate the effectiveness of BMP implementation to ensure compliance with this permit. I understand that it is the responsibility of the permittee to know and effectively evaluate the quality of the storm water being discharged. Lack of knowledge regarding storm water discharge or instream water quality shall not constitute a valid defense with regard to deficiencies in BMP implementation and maintenance, or negative impacts to water quality.

INSPECTION RESULTS: (Describe current activities, deficiencies, proposed corrective action(s) and compliance schedule, etc.)

"Based upon the inspection of (date & time) _____ which I or personnel under my direct supervision (list: _____) conducted, I certify that effective structural and non-structural BMPs have been fully implemented and regularly maintained to the maximum extent practicable for the prevention and minimization of all sources of pollution in storm water and authorized related process wastewater runoff, except for those deficiencies noted above, in accordance with the facility's BMP plan, good sediment, erosion, and other pollution control practices, EPA's Storm Water Management For Construction Activities - Developing Pollution Prevention Plans And Best Management Practices document, as amended, and with requirements of the above referenced NPDES permit and ADEM rules. I certify that discharges have been tested or evaluated for the presence of non-storm water and non-authorized process wastewaters.

I certify under penalty of law that this document and all attachments were prepared under my direction or supervision in accordance with a system designed to assure that qualified personnel properly gather and evaluate the information submitted. Based on my inquiry of the person or persons who manage the system, or those persons directly responsible for gathering the information, the information submitted is, to the best of my knowledge and belief, true, accurate, and complete. I am aware that there are significant penalties for submitting false information, including the possibility of fines and imprisonment for knowing violations."

Name of Qualified Credentialed Professional	Signature	Date
---	-----------	------

Name & Title of Permittee Responsible Official	Signature	Date
--	-----------	------

NONCOMPLIANCE NOTIFICATION REPORT

PERMITTEE NAME: _____

PERMIT NUMBER: ALR: _____

PERMIT AREA NAME _____

1. DESCRIPTION OF DISCHARGE:

NONCOMPLIANCE PARAMETER(S):

CAUSE OF NONCOMPLIANCE: (Attach additional pages if necessary)

2. PERIOD OF NONCOMPLIANCE: (Include exact date(s) and time(s) or, if not corrected, the anticipated time the noncompliance is expected to continue):

3. DESCRIPTION OF STEPS TAKEN AND/OR BEING TAKEN TO REDUCE OR ELIMINATE THE NONCOMPLYING DISCHARGE AND TO PREVENT ITS RECURRENCE (attach additional pages if necessary):

NAME AND TITLE OF RESPONSIBLE OFFICIAL (type or print)

SIGNATURE OF RESPONSIBLE OFFICIAL

DATE SIGNED

Appendix F - Spill Prevention and Pollution Control Plan



**SPILL PREVENTION, CONTROL, AND
COUNTERMEASURES PLAN**

**CHOCOLOCCO CREEK
WASTEWATER TREATMENT PLANT PROJECT
ANNISTON, ALABAMA**

JANUARY 2003

Submitted to:

Solutia Inc.
702 Clydesdale Avenue
Anniston, Alabama 36201-5390

Prepared by:

Golder Associates Inc.
3730 Chamblee Tucker Road
Atlanta, Georgia 30341

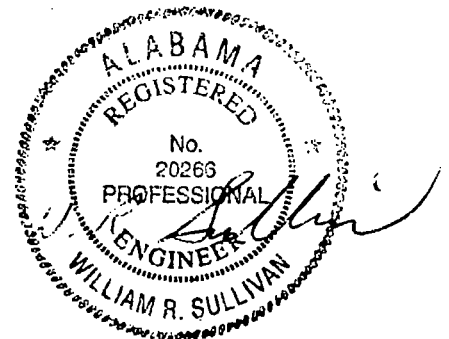

Jan. 16, 2003

TABLE OF CONTENTS

Table of Contents	i
-------------------------	---

<u>SECTION</u>	<u>PAGE</u>
1.0 INTRODUCTION	1
1.1 Background.....	1
1.2 NPDES Permit Authority	1
1.3 Purpose	1
1.4 Scope of Work	2
1.5 Approach and Overview.....	2
1.6 Mechanisms for Plan Revisions	2
1.7 Management Approval	3
2.0 SITE DESCRIPTION	4
2.1 Site Location and Description	4
2.2 Potential Sources of Pollution	4
2.2.1 Potential Pollutants in Soils.....	4
2.2.2 Construction Activities.....	4
2.2.3 Drainage	4
2.2.4 Spills.....	4
3.0 MEASURES AND CONTROLS.....	5
3.1 Spill Control Practices and Countermeasure.....	5
3.1.1 General	5
3.1.2 Spill Response	5
3.2 Good Housekeeping	6
3.2.1 General	6
3.2.2 Hazardous Products.....	7
3.2.3 Product Specific Practices	7
3.2.4 Employee Training	8
3.3 Stormwater Management.....	8
3.4 Erosion and Sedimentation Controls	8
3.5 Other Controls	8
3.5.1 Sanitary Waste.....	8
3.5.2 Hazardous Waste	8
3.5.3 Waste Materials	9
3.6 On-Site Vehicle and Personnel Tracking	9
3.6.1 General	9
3.6.2 Operations.....	9
3.6.3 Personnel Decontamination.....	9
3.7 Off-Site Vehicle Tracking	10
4.0 MAINTENANCE AND INSPECTION PRACTICES AND PROCEDURES.....	11
4.1 Erosion and Sedimentation Controls	11
4.1.1 Maintenance	11
4.1.2 Inspection	11
4.2 Record Keeping and Internal Reporting.....	11
4.3 Discharge Monitoring, Inspection, and Reporting Requirements	12
5.0 COMPREHENSIVE SITE COMPLIANCE EVALUATION.....	13
5.1 Inspection	13

TABLE OF CONTENTS – cont'd

<u>SECTION</u>	<u>PAGE</u>
5.2 Documentation and Corrective Action	13
6.0 REFERENCES	14

In Order
Following
Page 14

FIGURES

FIGURE 1 Site Location Map

ATTACHMENTS

ATTACHMENT A	Construction General Permit (GP) Notice of Intent (NOI) Package, Parts I-III
ATTACHMENT B	Certification Sheet
ATTACHMENT C	Environment Release Report Form
ATTACHMENT D	Inspection and Maintenance Report Forms

1.0 INTRODUCTION

1.1 Background

Solutia, Inc. (Solutia) intends to conduct corrective measures at the Choccolocco Creek Waste Water Treatment Plant (WWTP) in Anniston, Alabama. The activity will consist of consolidating and relocating away from the banks of Snow Creek, an existing stockpile of soils that contain polychlorinated biphenyls (PCB). Once relocated, these soils will be capped with a multi-layer cover system in an area within the property (but further east) owned by the Anniston Water & Sewer Board.

1.2 NPDES Permit Authority

The National Pollutant Discharge Elimination System (NPDES) is a national program for issuing, modifying, revoking, etc. permits under Sections 307, 318, 402, and 405 of the Clean Water Act of 1990. Under this program, the State of Alabama is authorized to implement a state-run program. This program requires that the Owner of a facility submit a Notice of Intent (NOI) when five (5) or more acres of land are disturbed through construction activities. In addition, the owner is required to develop a "Best Management Practice Plan" (BMP Plan) and a "Spill Prevention, Control, and Countermeasures Plan" (SPCC Plan). These plans should be fully developed and implemented upon submitting the NOI.

Solutia has elected to file a NOI for coverage under the Alabama Department of Environmental Management (ADEM) NPDES General Permit (Attachment A).

The NPDES General Permit requires Solutia to prepare and implement a BMP Plan describing practices to prevent/minimize the discharge of all sources of pollution in storm water runoff to State waters. The NPDES General Permit also requires Solutia to prepare, implement, and maintain a SPCC Plan for all on-site fuel or chemical storage tanks. The SPCC plan must be consistent with the requirements of 40 CFR 112.

1.3 Purpose

This document presents the SPCC Plan. The purpose of this SPCC Plan is to detail measures that will be undertaken to prevent and control possible releases of pollutants as a result of construction-related activities associated with the corrective action activities at the WWTP Project.

1.4 Scope of Work

The principal elements of work associated with this SPCC Plan pertaining to the WWTP project include the following major components:

- installation of a temporary stream crossing (across Snow Creek);
- general preparation of the work area;
- establishment of temporary facilities and roads;
- construction of a vehicle decontamination pad at the site;
- installation of erosion control structures;
- relocation and controlled placement of stockpiled soils;
- construction of the cover;
- equipment decontamination and disposal; and
- post-construction cleanup and seeding.

1.5 Approach and Overview

This SPCC Plan for the project was developed using USEPA and ADEM guidance documents and engineering judgment.

Pollution prevention-related planning presented in this SPCC Plan includes the following:

- identification of potential sources of construction-related pollution;
- measures and controls focused at limiting releases during construction, including emergency response;
- spill prevention; and
- the NPDES permit and other relevant plans.

1.6 Mechanisms for Plan Revisions

The SPCC Plan and all accompanying records, reports, and changes will be retained for the duration of the project plus three (3) years. This SPCC Plan will be reviewed and amended, at a minimum, when the following occurs:

- applicable ADEM or federal regulations are revised;
- the General NPDES Permit for the construction site is revised;
- the SPCC Plan fails in an emergency, or does not comply with the NPDES General Permit;
- there is a change in discharge design, operation, maintenance, or other circumstances, that materially increases the potential for fires, explosions, or releases of toxic or hazardous constituents; or that changes the response necessary in an emergency;
- as may otherwise be required by ADEM; and/or
- there is a reportable release of a hazardous substance to a storm water drain.

1.7 Management Approval

The USEPA and the State of Alabama require that the "Spill Prevention, Control, and Countermeasures Plan" be signed by an authorized person. A copy of the certification letter is in Attachment B.

The SPCC Plan will be retained on-site at the project offices and/or on-site trailers and will be available to members of ADEM upon request or, in the case of an unplanned storm water discharge from the site associated with construction. ADEM personnel, or an authorized representative with proper credentials and/or other documents as may be required by law, will be allowed during construction to:

- enter the premises of the project site and have access to the records that must be kept under the conditions of this plan;
- be able to copy, at reasonable times, any records that must be kept under the condition of this plan; and/or
- inspect, at reasonable times, any facilities, equipment, or structures.

2.0 SITE DESCRIPTION

2.1 Site Location and Description

The WWTP project is located within the City of Oxford, in northeastern Alabama, just south of Interstate 20. It is bounded on the west by Snow Creek, on the north by I-20, on the east by vacant woodland and residential areas and on the south by Choccolocco Creek. A site location map is shown on Figure 1.

The site was originally flat with a slight slope towards the southwest where storm water runoff flows towards Choccolocco Creek.

2.2 Potential Sources of Pollution

2.2.1 Potential Pollutants in Soils

Soils within the project site have been sampled by Solutia and have been shown to include PCB-containing soils.

2.2.2 Construction Activities

Construction activities will include earth-moving activities such as excavation and fill placement.

2.2.3 Drainage

Surface water drainage both within and surrounding the site property limits drain south and southwesterly mostly towards Choccolocco Creek.

2.2.4 Spills

Spills may occur from the usage of diesel fuel, gasoline, and the collection of rinse water that is used in the washing of equipment. Additionally, leaks of hydraulic oil might occur from the heavy equipment.

3.0 MEASURES AND CONTROLS

3.1 Spill Control Practices and Countermeasure

The Alabama NPDES General Permit for construction requires Solutia to prepare, implement, and maintain a SPCC Plan. The plan must be consistent with the requirements of 40 CFR 112 for tanks that meet or exceed the applicable size thresholds. In most situations, this would require construction of a containment system if the cumulative storage capacity of fuel or chemicals at the facility were greater than 1,320 gallons or if any single container has capacity greater than 660 gallons.

3.1.1 General

This section describes spill prevention and response procedures for the WWTP project that could contribute to pollutants to the storm water drainage system if improperly maintained. Spills may occur from the usage of diesel fuel and the collection of rinse water that is used in the cleaning of equipment. Additionally, leaks of hydraulic oil might occur from the heavy equipment. The general practices listed below will be followed for spill prevention and cleanup.

- Provisions will be made to prevent spills or leaks of fuels and/or oil products from refueling operations or equipment maintenance.
- Manufacturer's recommended methods for spill cleanup will be followed and site personnel will be made aware of the procedures and the location of the information and cleanup supplies.
- All spills will be cleaned up immediately after discovery.
- Spills of any toxic or hazardous material will be reported to the appropriate State or local government agency, as required.
- All materials and equipment necessary for spill cleanup will be kept in a designated material storage area or structure on-site.
- All equipment will refuel at a central location to be designated upon mobilization, and, during refueling operations, the equipment will not be unattended. Absorbent pads will be kept on-site in case an overfill occurs.

3.1.2 Spill Response

Spill response equipment, personal protective equipment (PPE), and first aid equipment will be stored at the project trailer as specified in the Health & Safety Plan (HASP). Personnel working will wear Level D or C protection, depending on the working conditions, and the health and safety requirements.

If a release occurs, the event will be documented utilizing the Environmental Release Report Form presented in Attachment C. Proper emergency response equipment must be used for its appropriate use:

Item	Use
Personal Protective Equipment: Tyvek coveralls Gloves Goggles PVC boots	Protect on-site response personnel from injury or potential exposure during incident response.
Spill Control Equipment: - bucket, broom - shovel - floor dry - absorbent pads - sand bags	Control and contain spilled liquid
Full-face respirators	Prevent inhalation hazards
First Aid Station	Provide basic first aid treatment of injured personnel
Emergency Eye Wash	Rinse foreign matter from eyes
Emergency Shower	Rinse foreign matter from skin
Fire alarm/communications system	Notify appropriate spill response personnel
Fire extinguishers	Fire control

In case of emergency, contact:

Emergency	Organization or Agency	Telephone No.
Injury	Emergency Medical Services	911
	Memorial Hospital	-----
Fire/Explosion	Anniston Fire Department	911
	Solutia Fire Department	-----
	Anniston Police Department	911
Hazardous Waste Spill or Release	ADEM-Birmingham Office	
	USEPA National Response Center	800-424-8802
	CHEMTREC	800-424-9300
Utilities	Alabama Power	-----
Other	Poison Control Agency	800-922-1117

3.2 Good Housekeeping

3.2.1 General

Good housekeeping is important on any construction project to minimize accidents and to ensure high quality work. The Contractor at the site has full responsibility and accountability for meeting good housekeeping requirements.

The "good housekeeping" practices listed below will be followed during the project.

- All erosion and sediment control measures will be kept in place, will be adequate for the erosion/sediment control of concern, will be properly constructed, and maintained.
- Clearing operations will be confined within the limits shown on the plans.

- The vegetation outside of the clearing area will be protected by not traveling into those areas.
- Controls will be instituted such that sediment transported from the site onto public right-of-way by vehicular traffic will be minimized.
- The sediment barriers, and related devices will be those that are effective in retaining sediment on the site.
- The appropriate vegetation will be established as needed on all specified areas, this includes temporary vegetation.
- Work progress will be in accordance with the proposed schedule.
- The contractor will follow the plan and construction sequence.
- As may be necessary, temporary stream channel crossings will be installed and maintained.
- No severe fire hazards will exist that could result in brush or grass fires.
- There will be no excessive sediment leaving the site for any reason.
- All materials stored on-site will be stored in a neat, orderly manner in their appropriate containers and, if possible, under a roof or other enclosure.
- Information sessions on good housekeeping practices will be incorporated into the employee meetings.
- Bulletin boards with updated good housekeeping procedures, tips and reminders will be posted for field personnel.

3.2.2 Hazardous Products

Below are listed the practices that will be used to reduce the risks associated with hazardous or regulated materials that are used on-site.

- Products will be kept in original containers unless they are not resealable.
- Original labels and material safety data sheets will be retained.
- If surplus product must be disposed of, manufacturers' or local and State recommended methods for proper disposal will be followed.

3.2.3 Product Specific Practices

The following specific practices for petroleum products will be followed on-site:

- All on-site vehicles will be monitored for leaks and receive regular preventive maintenance to reduce the chance of leakage.
- The mobile refueling tank will be regularly inspected and, when not refueling, kept in an area protected from damage by operating equipment.
- Petroleum products will be stored in tightly sealed containers, which are clearly labeled.
- Used oil or oil filters, batteries, and hydraulic fluid will be properly disposed.
- All necessary precautions to prevent leaks or spills from maintenance and refueling operations from coming in contact with the ground and/or storm water will be employed.

The specific practices listed below will be followed on-site when handling fertilizer products.

- Fertilizers used in temporary or permanent seeding operations will be applied only in the minimum amounts recommended by the manufacturer and worked into the soil to limit exposure to storm water.
- Storage of fertilizers will be in a covered shed.
- The contents of any partially used bags of fertilizer will be transferred to sealable plastic bins to avoid spills.

3.2.4 Employee Training

An effective training and education effort will be maintained for all site personnel. The training sessions will be held by the Construction Manager or the Project Engineer. The program will address the following:

- Training for the personnel authorized to perform the functions of inspections and administrative duties of the erosion and sediment control program.
- An initial training program for new employees or personnel such as inspectors, who will have an added duty of inspection for pollution prevention, is mandatory; an annual refresher course or training program will be planned.
- The existence, purposes and goal of the SPCC Plan will be reviewed with all personnel, identifying potential sources of storm water pollution at the site, BMPs employed at the site, and the role each employee fills in storm water pollution prevention.
- Pollution control laws and regulations will be overviewed.
- Good housekeeping material management practices will be overviewed.

3.3 **Stormwater Management**

The storm water management controls are detailed in the BMP Plan.

3.4 **Erosion and Sedimentation Controls**

The erosion and sedimentation controls are detailed in the BMP Plan.

3.5 **Other Controls**

3.5.1 Sanitary Waste

All sanitary waste will be collected from the portable units and trailer holding tanks by a licensed sanitary waste management contractor, as required by local regulation.

3.5.2 Hazardous Waste

All hazardous waste and materials will be transported and disposed of by Solutia in accordance with Federal, State, and local regulations. The Construction Manager will be responsible for seeing that these

practices are followed.

3.5.3 Waste Materials

All non-combustible waste materials will be collected and stored in dumpsters that will meet all County and State solid waste management regulations.

All combustible trash and construction debris from the site will be managed in accordance with ADEM regulations. The dumpster will be emptied as often as is necessary, and the trash will be hauled to an approved landfill. No construction materials will be buried on-site. All personnel will be instructed regarding the correct procedure for waste disposal.

3.6 **On-Site Vehicle and Personnel Tracking**

3.6.1 General

It is anticipated that personnel and equipment will be required to manage on-site PCB-containing soils. Additionally, personnel and equipment will be required to operate within the soil stockpile area.

3.6.2 Operations

The defined areas of PCB-containing earthworks will be flagged and taped, to identify it as the "exclusion zone". Equipment to be employed in managing PCB-containing materials in the exclusion zone will remain in the exclusion zone until it is no longer needed. To limit the potential for inadvertent transfer of PCB-containing materials out of the area, all equipment leaving the exclusion area will need to be cleaned.

3.6.3 Personnel Decontamination

To the extent practical, personnel will be kept from entering the exclusion zone. Nonetheless, an area for PPE removal and personnel decontamination will be staged adjacent to the exclusion zone of each area of PCB-containing soils, to include:

- boot wash tubs;
- disposal containers for PPE (i.e., Tyvek, gloves, etc.);
- hand wash buckets;
- first aid kit to provide immediate first aid supplies; and
- fire extinguishers readily available to handle emergencies.

3.7 Off-Site Vehicle Tracking

A stabilized construction entrance will be provided to help reduce vehicle tracking of sediments off-site. All construction equipment entering the exclusion zone will stay within the zone until the equipment is no longer required. This equipment will be properly cleaned before leaving the site. Other construction vehicles not used in the exclusion zone will not enter the zone.

4.0 MAINTENANCE AND INSPECTION PRACTICES AND PROCEDURES

4.1 Erosion and Sedimentation Controls

4.1.1 Maintenance

The maintenance practices listed below will be used to maintain erosion and sedimentation controls during construction activities.

- Less than 10 acres will be denuded at one time.
- Measures, as outlined in Section 3.0, will be maintained in good working order. If a repair is necessary, it will be initiated within 24 hours of report.
- Built-up sediment will be removed from silt fence when it has reached one-third to one-half of the height of the fence.

4.1.2 Inspection

The inspection practices listed below will be used to maintain erosion and sedimentation controls during construction activities.

- The Construction Manager will select individuals who will be responsible for inspections, maintenance and repair activities, and filling out the inspection and maintenance report. Personnel selected for inspection and maintenance responsibilities will receive training. They will be trained in all the inspection and maintenance practices necessary for keeping the erosion and sediment controls used on-site in good working order.
- A maintenance inspection report will be made after each inspection. A copy of a report form to be completed by the inspector is in Attachment D.
- All control measures will be inspected a minimum of twice a month with monthly inspections a minimum of two weeks apart, or within 48 hours after precipitation accumulation of 0.75 inch or greater, since the last inspection (ADEM General Permit Part I Section B 1).
- Sites that have been finally stabilized will have an inspection of all control measures at least once every month.
- Silt fence will be inspected for depth of sediment, tears, to see if the fabric is securely attached to the fence posts, and to see that the fence posts are firmly in the ground.
- Sediment traps will be inspected for depth of sediment.
- Sediment control structures will be inspected for erosion, piping, and displacement after each significant rainstorm and repaired immediately.
- Temporary and permanent seeding and planting will be inspected for bare spots, washouts, and healthy growth.

4.2 Record Keeping and Internal Reporting

Maintaining records for all inspections is an important element of any SPCC Plan. Documenting all inspections, whether routine or detailed, is a good preventive maintenance technique, because analysis of inspection records allows for early detection of any potential problems. Record keeping also helps to devise improvements in the SPCC program after inspection records have been analyzed. Record keeping

and reporting for maintenance activities will also be a part of the plan as another preventive maintenance measure. A log will be kept of all maintenance activities, evaluation of the effectiveness of the SPCC program, equipment, and operation. SPCC Plan-related record keeping will be handled in conjunction with the BMP Plan-related record keeping.

A variety of techniques to accurately document and report inspection results that will include the following:

- field notebooks;
- timed and dated photographs;
- video tapes; and
- drawing and maps.

Records of spills, leaks, or other discharges, inspections, and maintenance activities will be retained for at least one year after coverage under the permit expires.

All inspection forms will be maintained at the site in a separate three-ring binder in the Construction Manager's office. This book will be available for review by appropriate personnel by request.

4.3 Discharge Monitoring, Inspection, and Reporting Requirements

The Alabama NPDES General Permit for construction requires certain monitoring, inspection, and record keeping. These requirements can be found in the NPDES General Permit under Part I (see Attachment A). Inspection and Maintenance Report Forms to be filled out during the inspection are included in Attachment D. This form will be completed and retained in the Construction Manager's Office. An additional form to be completed is the Environmental Release Report Form. This form can be found in Attachment C of this document.

Other Report Forms to be filled out are the Inspection Report and BMP Certification, the Noncompliance Notification Report, and the Discharge Monitoring Report. These worksheets and report forms will be submitted to ADEM as specified in the NPDES General Permit, Part I, Section C and D (see Attachment A). These forms are required to be completed by the owner or his designee.

Note: The Worksheets and Report Forms in this document are "master" copies. Please make a photocopy to use as a "working" copy and return the master copy to the SPCC Plan for future use.

5.0 COMPREHENSIVE SITE COMPLIANCE EVALUATION

5.1 Inspection

All areas of the site that could contribute to storm water pollution by petroleum based products will be inspected at least weekly by the Construction Manager and at least one other member from the Project Team.

All areas contributing to a storm water discharge associated with construction will be visually inspected for evidence of, or the potential for, pollutants entering the drainage system. Measures to reduce pollutant loading will be evaluated to determine whether they are adequate and properly implemented, or if additional control measures are needed. The inspectors will also observe structural storm water management measures (detailed in the BMP Plan), sediment and erosion control measures (detailed in the BMP Plan), and other pollution prevention measures identified in this plan to ensure that they are operating correctly. Equipment needed to implement the plan, such as spill response equipment, will be visually inspected.

The inspector will verify that all areas identified as potential sources of pollution are inspected regularly and that the inspections are documented in his daily field log.

5.2 Documentation and Corrective Action

As discussed above, any problems associated with SPCC compliance will be noted on completed daily field logs. Problems will then be discussed, resolved, and corrective action will be implemented, as required, by the Project Team. Any actions taken as a result of the inspection will be documented. Section 3 of this plan, Measures and Controls, will be revised within two weeks of the inspection if necessary and will contain the proposed dates of implementation of any improvements to be made. The improvement must occur within four weeks after the inspection.

Copies of any forms/documents which detail SPCC inspection results will be retained until one year after the expiration of the Solutia facility's General NPDES permit for the discharge of storm water associated with industrial activities.

6.0 REFERENCES

- Alabama Non-Point Source Management Program Document*, as amended, Alabama Department of Environmental Management, Water Division - Mining & Non Point Source Section, in accordance with Section 319 of the Federal Clean Water Act, as amended.
- Stormwater Discharge Monitoring and Sampling Requirements NPDES General Permit ALG610000 - Construction and Other Land Disturbance Activity*, Alabama Department of Environmental Management, Guidance Documentation, February 1, 1993.
- Application Guidance for NPDES Permit for Stormwater Discharges from Construction, Excavation, Land Clearing, Other Land Disturbance Activities, and Associated Areas Not Authorized by an Existing NPDES Permit General Permit Number ALG610000*, Alabama Department of Environmental Management, Mining & Non Point Source Section, MNPS Form 200-A, 8/1/92.
- Stormwater Management for Construction Activities - Developing Pollution Prevention Plans and Best Management Practices*, United States Environmental Protection Agency, Office of Water, 1993.
- EPA Stormwater Pollution Prevention for Construction Activities*, United States Environmental Protection Agency, Office of Wastewater Enforcement, and Compliance, as amended.

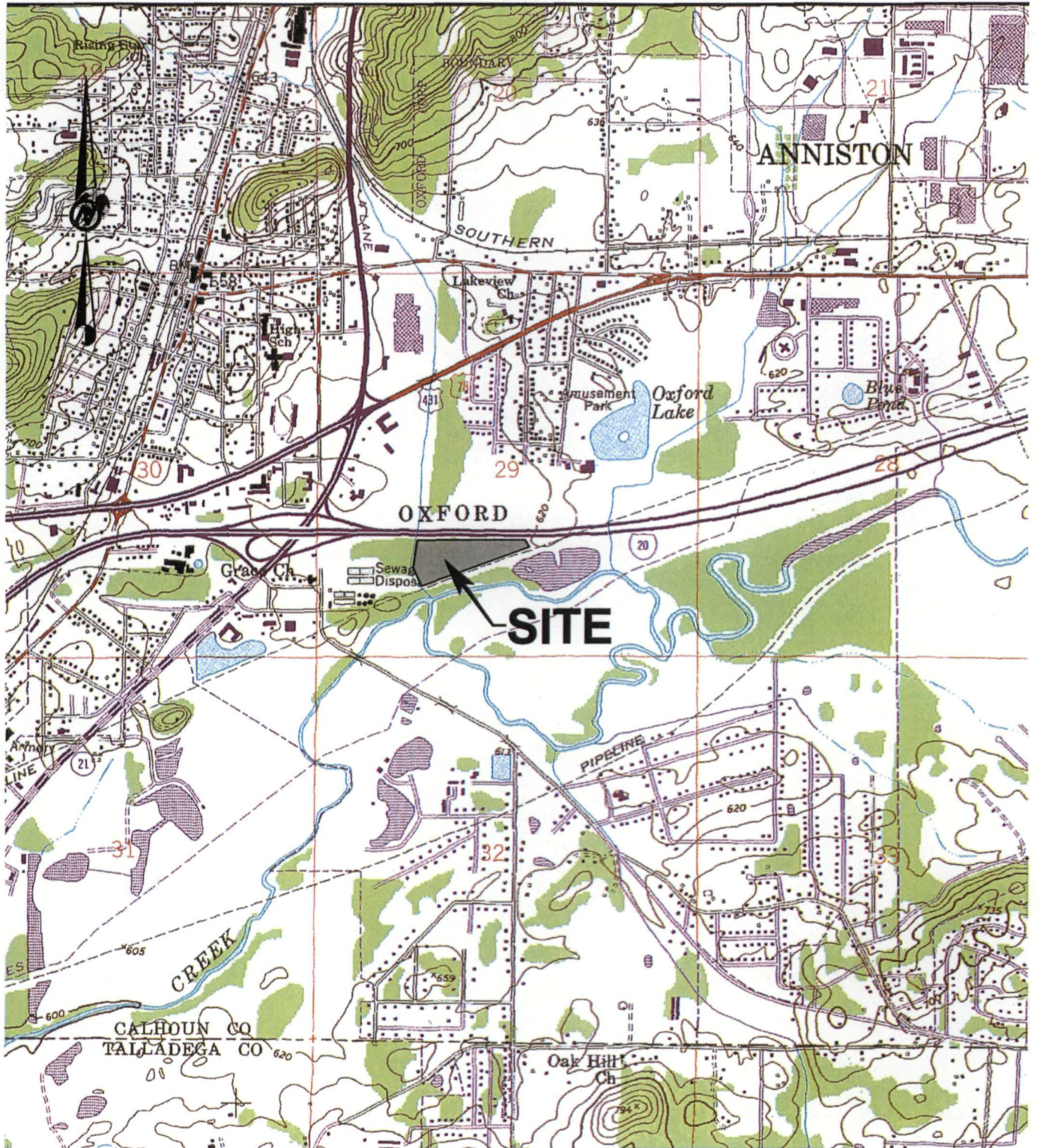

REF: USGS 7.5 MINUTE
OXFORD QUADRANGLE

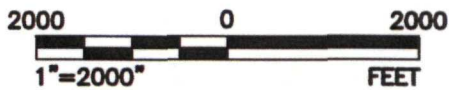

REV	DATE	DES	REVISION DESCRIPTION	CADD	CHK	RW
-	-	-	-	-	-	-
PROJECT						
SOLUTIA INCORPORATED CHOCOLOCCO CREEK WWTP ANNISTON, ALABAMA						
TITLE						
SITE LOCATION MAP						
PROJECT No. 934-3680			FILE No. 9433680WTPCHAR06			
DESIGN	-	-	SCALE AS SHOWN		REV. -	
CADD	RMS	01/03	1			
CHECK						
REVIEW						



ATTACHMENT A

Construction General Permit (GP) Notice of Intent (NOI) Package, Parts I-III

TO BE SUBMITTED UNDER SEPARATE COVER

ATTACHMENT B

Certification Sheet

CHOCOLOCCO CREEK WASTE WATER TREATMENT PLANT PROJECT

**SOLUTIA INC., ANNISTON, ALABAMA
SPILL PREVENTION, CONTROL, AND COUNTERMEASURES PLAN**

JANUARY, 2003

REVISION: 0

MANAGEMENT APPROVAL

"I certify under penalty of law that this document and all attachments were prepared under my direction of supervision in accordance with a system designed to assure that qualified personnel properly gathered and evaluated the information submitted. Based on my inquiry of the person or persons who manage the system, or those persons directly responsible for gathering the information, the information submitted is, to the best of my knowledge and belief, true, accurate, and complete. I am aware that there are significant penalties for submitting false information, including the possibility of fines and imprisonment for knowing violations."

SOLUTIA INC.

Name (Type or Print)	Title
Signature	Date

CONTRACTOR APPROVAL

"I certify under penalty of law that I understand the terms and conditions of the general National Pollutant Discharge Elimination System (NPDES) permit that authorizes the storm water discharge associated with industrial activity from the construction site identified as part of this certification."

CONTRACTOR: _____

Name (Type or Print)	Title
Signature	Date

ATTACHMENT C

Environment Release Report Forms

CHOCOLOCCO CREEK WASTE WATER TREATMENT PLANT PROJECT

**SOLUTIA INC., ANNISTON, ALABAMA
CHEMICAL RELEASE RPORT FORM**

(Sheet 1 of 1)

1. Date of Release: _____ 2. Approximate Time of Release: _____

3. Approximate Duration of Release: _____ 4. Quantities Released: _____

5a. Chemicals or Constituents Released:

5b. Release to (check media as appropriate): Air _____ Storm Drainage System _____
Other Surface Water _____ Soil _____

Description of Incident (Location, Source, Cause)

7. Response Action Taken: _____

8. Corrective Measures Taken: _____

Anticipated Consequences of Incident (environmental, need for further corrective action, etc):

10. Verbal Report Filed: Time _____ Date: _____ By: _____

To: _____ of _____ (Agency or Organization)

CHOCOLOCCO CREEK WASTE WATER TREATMENT PLANT PROJECT

SOLUTIA INC., ANNISTON, ALABAMA ENVIRONMENTAL RELEASE REPORT FORM

(Sheet 1 of 2)

1. Inspection Team: _____ 2. Date: _____
_____ 3. Time: _____

4. Date of Last Inspection: _____ 5. Days Since Last Inspection: _____
6. Days Since Last Rain Event: _____ 7. Quantity of Last Rain: _____
8. Quantity of rain since Last Inspection: _____
9. Summary Inspection Checklist:

Item	Comments
1. Maintain containment of select soil	
2. Maintain soil and erosion control measures	
3. Maintain storm water conveyances	
4. Promptly clean up any minor fuel spills	
5. All vehicles cleaned as necessary before leaving the site or exclusion zones	
6. Promptly remove litter or debris	
7. Spill response equipment in place	

10. General Notes:

CHOCOLOCCO CREEK WASTE WATER TREATMENT PLANT PROJECT

**SOLUTIA INC., ANNISTON, ALABAMA
ENVIRONMENTAL RELEASE REPORT FORM**

(Sheet 2 of 2)

11. Description and Volume of Observed Flows Into Stormwater Drainage System: _____

12. Comments: _____

13. Items for Corrective Action: _____

14. Date of Revision of Spill Prevention, Control, and Countermeasures Plan (SPCC):

15. Date of Implementation of Corrective Actions: _____

(use additional sheets if necessary)

ATTACHMENT D

INSPECTION AND MAINTENANCE REPORT FORM

**CHOCOLOCCO CREEK WASTE WATER TREATMENT PLANT
CONSTRUCTION OF SOIL CAP
INSPECTION AND MAINTENANCE REPORT**

Site Name: _____

Site location (City, County, State): _____

NPDES Permit Number: ALR _____

Weekly Rainfall Summary

Day	SUN	MON	TUE	WED	THU	FRI	SAT
Date							
Rainfall							

Sampling Information

Sample Type:

Location:

Analysis:

Inspection Results

Deficiencies or Required Maintenance:

Planned Corrective Action:

Corrective Action Schedule:

Other Comments:

Signature

Date

Appendix G - Dust Control Plan



**DUST CONTROL PLAN
CHOCOLOCCO CREEK
WASTE WATER TREATMENT PLANT
PROJECT
ANNISTON, ALABAMA**

JANUARY 2003

Submitted to:

Solutia Inc.
702 Clydesdale Avenue
Anniston, Alabama 36201-5390

Prepared by:

Golder Associates Inc.
3730 Chamblee Tucker Road
Atlanta, Georgia 30341

TABLE OF CONTENTS

Table of Contents i

<u>SECTION</u>	<u>PAGE</u>
1.0 INTRODUCTION	1
1.1 Background.....	1
1.2 Purpose	1
1.3 Scope of Work.....	1
1.4 Site Location and Description.....	1
2.0 ENGINEERING CONTROLS FOR DUST.....	2
2.1 Responsibilities	2
2.2 Description of the Engineering Controls.....	2
2.2.1 Watering	2
2.2.2 Control of Transportation Dust	2
2.2.3 Materials Handling.....	3
2.2.4 Odor.....	3
3.0 SITE STANDARDS FOR DUST.....	4
3.1 Surveillance Objectives.....	4
3.2 General Monitoring Guidelines.....	4
3.3 Monitoring Parameters and Location of Monitoring Events	4
3.4 Implementation.....	5
3.5 Action Levels	5
3.6 Reporting Results Of Air Surveillance Activities.....	5

In Order
Following
Page 5

FIGURES

FIGURE 1 Air Monitoring Log

1.0 INTRODUCTION

1.1 Background

Solutia Inc. (Solutia) will perform interim corrective measures at the Choccolocco Creek Waste Water Treatment Plant in Anniston, Alabama. These measures will include the consolidation and relocation of a soil stockpile containing polychlorinated biphenyls (PCBs). Soils with PCB concentrations of greater than 1 ppm will be graded to create an embankment. Once grading has been completed, the PCB-containing soil will be capped with a multi-layered cover system and vegetated. The cover system will consist of a geomembrane overlain by a geocomposite drainage layer and 24 inches of soil. Runoff from the covered embankment will be allowed to sheet flow to Choccolocco Creek.

1.2 Purpose

The purpose of this Dust Control Plan (DCP) is to describe in detail the strategies for controlling the release of dust from the construction activities.

1.3 Scope of Work

The principal elements of work associated with this DCP are listed below:

- establishment of temporary stream crossing, entrance and roads;
- general preparations of the work area;
- installation of erosion control structures;
- construction of a vehicle decontamination pad at the site;
- consolidation and relocation of PCB-containing soil;
- construction of the multi-layer cover over PCB-containing soil;
- equipment decontamination and disposal; and
- post-construction cleanup and seeding.

1.4 Site Location and Description

The WWTP project is located within the City of Oxford, in northeastern Alabama, just south of Interstate 20. It is bounded on the west by Snow Creek, on the north by I-20, on the east by vacant woodland and residential areas and on the south by Choccolocco Creek.

The site was originally flat with a slight slope towards the southwest where runoff flows toward Choccolocco Creek.

2.0 ENGINEERING CONTROLS FOR DUST

2.1 Responsibilities

The Construction Manager is responsible for the implementation of the Dust Control Plan. He is authorized to direct site activities as needed to carry out this responsibility. He may authorize other senior site staff to support administration of this function. Dust control and monitoring, however, are the responsibility of the Contractor.

The Construction Manager (or his designee) as required by site conditions, will collect information from on-site monitoring equipment, the Site Health and Safety Officer (SHSO), and other sources to judge the adequacy of ongoing dust control efforts, and take corrective action as needed. The Construction Manager will be empowered to immediately take actions in all cases where on-going site activity must be modified or delayed to conduct work in a manner as to limit or control dust.

2.2 Description of the Engineering Controls

The following sections describe in detail the engineering controls and work practices to be used to control dust throughout the project.

2.2.1 Watering

Water will be applied to site and work area surfaces where other engineering controls (such as the use of temporary liners) are not employed and when airborne dust is present.

The water will be applied by water trucks using a gravity distribution bar and/or a pressure spray system.

2.2.2 Control of Transportation Dust

Speed limits for site vehicles will be established at 10 miles per hour and enforced in order to limit the generation of dust from their travel. Disciplinary actions will be taken against all individuals for violation of site speed limits. All operators will be instructed to report visible dust immediately.

The Construction Manager will ensure that haul and access roads and pathways are maintained in order to properly control of dust. Material transport vehicles will be loaded in a manner to avoid spillage during transport. If the loads appear to be dusty, the load will be wetted prior to transportation. Any spillage of materials during transport will immediately be cleaned up.

2.2.3 Materials Handling

Planning and scheduling of work activities will be utilized to minimize the number of times the materials are handled or disturbed. Excavation, stockpile, and placement work areas will be planned to limit the amount of work area exposed to the minimum necessary to support construction activities.

Soils exposed during excavation activities will be kept sufficiently moist to prevent the generation of dust.

Temporary stockpiles of materials may be necessary to conduct the work. These piles will also be kept sufficiently moist to prevent the generation of dust. However, if the winds become such that watering is not effective, the exposed areas will be completely covered by 5 or 10 mil plastic sheeting. The sheeting will be sufficiently secured to prevent it from being damaged or from blowing off.

2.2.4 Odor

Organic emissions are not expected at the site. However, the site will be monitored and the appropriate action taken if they are detected as provided for in the **Site Specific Health and Safety Plan (HASP)**. If odors are detected at the site, they will be controlled by limiting the amount of material exposed, by continuous water misting, or other controls that may be necessary. Odors generated by material in transport vehicles will be controlled by covering and sealing the material in the vehicle with plastic sheeting.

3.0 SITE STANDARDS FOR DUST

3.1 Surveillance Objectives

This section specifies the surveillance activities that will take place during the Solutia Project. Air surveillance objectives include:

- characterizing breathing zone concentrations of respirable dust;
- determining the appropriateness of respiratory protective equipment; and
- monitoring the performance of dust control activities.

3.2 General Monitoring Guidelines

Real time air monitoring using mini-rams or equivalent will be conducted as a part of regular operations. Guidelines for sequence and frequency of monitoring activities are as follows:

- when work begins at a different area of the site;
- if new areas of affected materials are discovered or if constituents other than those previously identified are handled;
- when a new operational procedure is introduced;
- before and during confined space entry;
- upon request, real time air monitoring will be conducted in the presence of the construction manager or his representative;
- when special or unusual conditions warrant this action as determined by the SHSO; and
- the frequency of monitoring increases as dust concentrations approach an action limit.

3.3 Monitoring Parameters and Location of Monitoring Events

Respirable Dust (Mini-ram brand or equivalent) monitoring is to be used during construction for fence line, work zone perimeter and breathing zone monitoring. Breathing zone monitoring will be conducted at a frequency, which will allow the characterization of the range of exposures experienced by each job classification involved in earth moving activities (e.g., track hoe operator, dump truck operator, ground crew, member). Work zone perimeters defined, as a distance not more than 50 feet from earth moving activities, will be monitored at the discretion of the Construction Manager in areas where PCB concentrations are present. The SHSO will use work zone perimeter data to inform the crew and supervision of dust control effectiveness.

Fence line monitoring will be conducted at upwind and downwind locations of the project site. Monitoring locations will be documented on a site map. Wind direction will also be determined. The action levels for respirable dust in the Work areas and at the fence line are specified below.

3.4 Implementation

The SHSO is responsible for:

- daily calibration of all instruments in accordance with manufacturer's instructions,
- documentation of calibration, instrument readings and site conditions/activities during monitoring;
- directing activities with regard to air monitoring results; and
- communicating results to employees, supervision and client representative.

3.5 Action Levels

Field team personnel shall observe the action levels specified below. If questions arise regarding the applicability or alternation of these levels, the SHSO must be consulted. Actions are implemented when an instrument sustains a reading above the action level for at least two minutes.

INSTRUMENTS AND ACTION LEVELS

Instrument	Action Level	Specific Action
Respirable Dust Monitor*	Background to 0.5 mg/m ³ at Fence Line	Maintain dust control procedures
	= 0.5 mg/m ³ at Fence Line	Notify Supervision
	> 0.5 mg/m ³ at Fence Line	Stop Work

Other action levels shall be as specified in the Contractor's Health and Safety Plan.

3.6 Reporting Results Of Air Surveillance Activities

Air monitoring data will be recorded onto Air Monitoring Logs. Air Monitoring Logs will be kept on-site by the SHSO. Excursions above the action limits discussed under Section 3.5 will be reported to the Solutia representative immediately. A copy of the Air Monitoring Log is provided (Figure 1).

Appendix H - Health and Safety Plan Template



HEALTH AND SAFETY PLAN GUIDELINES
CHOCOLOCCO CREEK
WASTEWATER TREATMENT PLANT PROJECT
ANNISTON, ALABAMA

JANUARY 2003

Submitted to:

Solutia Inc.
702 Clydesdale Avenue
Anniston, Alabama 36201-5390

Prepared by:

Golder Associates Inc.
3730 Chamblee Tucker Road
Atlanta, Georgia 30341

TITLES AND APPROVALS

The undersigned certify that this Solutia Inc. (Solutia) Health and Safety Plan Guidelines is approved and will be utilized for the construction activities at the Choccolocco Creek Waste Water Treatment Plant in Anniston, Alabama.

_____ Craig Branchfield Solutia Project Manager	_____ Date
_____ John Loper Corrective Measure Implementation Manager	_____ Date
_____ To be determined Health and Safety Officer	_____ Date
_____ To be determined Health and Safety Coordinator	_____ Date
_____ To be determined Site Safety Officer	_____ Date

TABLE OF CONTENTS

<u>SECTION</u>	<u>PAGE</u>
1.0 INTRODUCTION.....	1
2.0 SITE DESCRIPTION.....	2
2.1 Site Location And Description.....	2
2.2 Scope of Work	2
3.0 HEALTH AND SAFETY ORGANIZATION AND COORDINATION.....	3
3.1 Project Management Team	3
3.2 Solutia Project Manager.....	3
3.3 Corrective Measures Implementation Manager	3
3.4 Construction Manager.....	3
3.5 Health and Safety Officer	3
3.6 Health and Safety Coordinator.....	4
3.7 Site Safety Officer.....	4
3.8 Contractor Responsibilities.....	5
3.9 Visitors.....	5
3.10 Record Keeping Responsibilities	5
4.0 HAZARD EVALUATION	6
4.1 General.....	6
4.2 Field Activities.....	6
4.3 Chemical Hazards	6
4.3.1 Exposure via Ingestion.....	7
4.3.2 Exposure via Dermal Contact	7
4.3.3 Exposure via Inhalation	7
4.4 Physical Hazard Review	8
4.4.1 Operation of Heavy Equipment	8
4.4.2 Confined Space Entry	8
4.4.3 Heat Stress	9
4.4.4 Cold Stress	12
4.4.5 Noise	13
4.4.6 Manual Lifting	13
4.4.7 Slip, Trip and Fall Hazards	13
4.4.8 Electrical Equipment.....	13
4.4.9 Trenching/Excavation	13
4.4.10 Falling Objects.....	13
4.5 Biological Hazard	14
4.5.1 Insect Bites and Stings	14
4.5.2 Tick Bites.....	14
4.5.3 Snake Bites.....	15
4.5.4 Plants.....	16
5.0 TRAINING REQUIREMENTS	17
5.1 Basic Training.....	17
5.2 Pre-Work Briefing	17
5.3 Daily Briefings.....	17
5.4 First Aid and CPR.....	18
5.5 Documentation.....	18

5.6	Hazard Communication	18
6.0	SITE CONTROL PROCEDURES.....	19
6.1	Site Entry And Exit.....	19
6.2	Daily Start Up	19
6.3	Area Operations	19
6.4	Dust Control.....	20
7.0	DUST MONITORING REQUIREMENTS.....	21
7.1	General.....	21
7.2	Real-Time Monitoring	21
7.3	Dust Action Levels	22
8.0	WORK TASKS AND PERSONAL PROTECTIVE EQUIPMENT REQUIREMENTS.....	23
8.1	General.....	23
8.2	Respiratory Protection Program.....	23
8.3	PPE Protection Summary.....	24
8.3.1	Level D Equipment	24
8.3.2	Level C Equipment	24
9.0	DECONTAMINATION PROCEDURES.....	26
9.1	General.....	26
9.2	Contamination Prevention.....	26
9.3	Decontamination Equipment.....	26
9.4	Personal Decontamination	27
9.5	Equipment Decontamination.....	28
9.5.1	Monitoring Equipment.....	28
9.5.2	Respiratory Protective Equipment	28
9.5.3	Excavation Equipment	28
10.0	SAFETY CONSIDERATIONS AND ACCIDENT PREVENTION.....	30
10.1	Safety Considerations	30
10.2	Task Specific Accident Prevention	31
10.2.1	Personal Protective Equipment	31
10.2.2	Work Practices	32
11.0	MEDICAL MONITORING REQUIREMENTS.....	33
11.1	Routine Examination	33
11.2	Non-Routine Medical Examination	33
12.0	EMERGENCY EQUIPMENT AND FIRST AID REQUIREMENTS.....	34
12.1	Communications	34
12.2	First Aid Emergency Equipment.....	35
12.3	Personal Injury.....	35
12.4	General First Aid Procedures.....	35
12.5	Blood-Borne Pathogens	36
12.6	Adverse Weather Conditions	36
12.7	Emergency Information	36
12.7.1	Emergency Phone Numbers.....	36
12.7.2	Project Emergency Contacts	37
13.0	SITE EMERGENCY PLAN.....	38
13.1	General.....	38

13.2 Emergency Coordinator 38
13.3 Communication..... 39
13.4 Emergency Plan Execution And Implementation 39
13.5 Emergency Response Procedures For Spills, Fires And Explosions 40
 13.5.1 Liquid Spill 40
 13.5.2 Solid Spill..... 40
 13.5.3 Fire 40
 13.5.4 Explosion 40
13.6 Evacuation Plan 41
14.0 REPORTING REQUIREMENTS..... 42
 14.1 Health And Safety Logbook 42
15.0 REFERENCES..... 43

In Order
Following
Page 43

TABLES

TABLE 1 Action Levels of Chemicals Expected
TABLE 2 Heat Stress: Basis for Work Schedule
TABLE 3 Action Levels for Personal Protection and/or Work Stoppage
TABLE 4 Activities PPE Requirements

FIGURES

FIGURE 1 Site and Hospital Location
FIGURE 2 Outline for Level C Decontamination
FIGURE 3 Outline for Level D Decontamination

APPENDICES

APPENDIX A Health and Safety Plan Addendum/Revision Form
APPENDIX B Toxicological Data for Selected Chemicals
APPENDIX C OSHA 101 Form for Occupational Injuries and Illnesses
APPENDIX D Health and Safety Plan Signature Form
APPENDIX E "Tailgate" Safety Meeting Form
APPENDIX F Dust Monitoring Data Record Sheet
APPENDIX G Miniram Standard Operating Procedures

1.0 INTRODUCTION

This Health and Safety Plan (HS Plan) Guidelines have been developed for the protection of the project team and other persons that may be exposed to hazards associated with the implementation of the corrective measures for the excavated soil stockpile at Choccolocco Creek Wastewater Treatment Plant (CCWWTP) in Anniston, Alabama. The purpose of this HS Plan is to assign responsibilities, establish personal protection standards, specify and establish safe operating procedures and practices, and provide for contingencies that may arise while conducting response action activities at the site. Each contractor shall prepare and conform to a health and safety plan, which provides planning at least as stringent as these guidelines.

This HS Plan has been prepared based upon the requirements pertaining to hazardous waste activities outlined in the following regulations, guidelines, and manuals:

- Code of Federal Regulations (CFR), Title 29, part 1910 (29 CFR 1910);
- Code of Federal Regulations (CFR), Title 29, part 1910 (29 CFR 1926);
- Guidelines prepared by National Institute for Occupational Health and Safety (NIOSH), Occupational Safety and Health Administration (OSHA), U.S. Coast Guard (USCG), and the U.S. Environmental Protection Agency; and
- Manual entitled "Occupational Safety and Health Guidance Manual for Hazardous Waste site Activities (1985)".

Site activities require a high level of safety planning. Adequate planning is the first and most critical element in controlling exposure to hazardous materials and situations. Accordingly, proper safety techniques and safety equipment are an integral part of each specified task of the project. This plan addresses those safety procedures and equipment that shall be used to minimize the probability of personnel injury or chemical exposure during on-site activities.

This HS Plan is based on the information available concerning the possible chemical and physical hazards found on the site. As additional site-specific information becomes available, this HS Plan may be modified accordingly. The form for completing the HS Plan Addendum/Revision is presented in Appendix A.

2.0 SITE DESCRIPTION

2.1 Site Location And Description

The WWTP project is located within the City of Oxford, in northeastern Alabama, just south of Interstate 20. It is bounded on the west by Snow Creek, on the north by I-20, on the east by vacant woodland and residential areas and on the south by Choccolocco Creek.

The site was originally flat with a slight slope towards the southwest where runoff flows toward Choccolocco Creek.

2.2 Scope of Work

The principal elements of work associated with this HS Plan are listed below:

- establishment of temporary stream crossing, entrance and roads;
- general preparations of the work area;
- installation of erosion control structures;
- construction of a vehicle decontamination pad at the site;
- consolidation and relocation of PCB-containing soil;
- construction of the multi-layer cover over PCB-containing soil;
- equipment decontamination and disposal; and
- post-construction cleanup and seeding.

3.0 HEALTH AND SAFETY ORGANIZATION AND COORDINATION

3.1 Project Management Team

The key personnel listed below will be responsible for the supervision and implementation of the requirements outlined in the HS Plan for the site.

- Solutia Project Manager: Craig Branchfield
- Corrective Measures Implementation Manager: John Loper
- Construction Manager: Donn Williams
- Health and Safety Officer (HSO): To be determined
- Health and Safety Coordinator (HSC): To be determined
- Site Safety Officer (SSO): To be determined

3.2 Solutia Project Manager

The Solutia Project Manager has overall responsibility for all projects associated with the Solutia, Anniston, Alabama facility. The Solutia Project Manager has final authority for decisions made by the response team associated with the Choccolocco Waste Water Treatment Plant (WWTP) corrective measures implementation activities.

3.3 Corrective Measures Implementation Manager

The Corrective Measures Implementation Manager has overall responsibility for the management and technical oversight of the WWTP corrective measures implementation project. The Corrective Measure Implementation Manager acts as a liaison between the Solutia Project Manager and the construction teams.

3.4 Construction Manager

The Construction Manager is responsible for implementing and directing construction operations in accordance with project requirements. The Construction Manager has overall responsibility for the management of contractors selected to perform the selected construction activities. The Construction Manager reports directly to the Corrective Measure Implementation Manager. The Construction Manager along with the Site Safety Officer has stop-work authority if unsafe conditions are present.

3.5 Health and Safety Officer

The Health and Safety Officer (HSO) is the primary reviewer of the HS Plan and is responsible for health and safety technical support.

3.6 Health and Safety Coordinator

The Health and Safety Coordinator (HSC) is responsible for the implementation of the HS Plan at the site. The responsibilities of the HSC include:

- functioning as the communications liaison between project team and HSO and as such reports directly to the HSO and Construction Manager;
- informing personnel of potential hazards associated with the site;
- maintaining current documentation of the site personnel's health and safety training;
- working closely with the SSO regarding health and safety issues; and
- approving changes in the HS Plan.

3.7 Site Safety Officer

The Site Safety Officer (SSO) is the contractor's representative responsible for the on-site enforcement of the policies and provisions contained in the HS Plan. The responsibilities of the SSO include:

- ensuring that each member of the investigative team is up to date on safety training (e.g., OSHA 40-hour Hazardous Waste Operations and Emergency Response (HAZWOPER), OSHA 8-hour refresher, cardiopulmonary resuscitation (CPR), and/or first aid);
- meeting with the HSC to evaluate site operations and understand strategies;
- assisting the HSC in enforcing the HS Plan;
- functioning as the communications liaison between the project field team and the HSC and Construction Manager;
- making sure that the necessary safety equipment is available and operational, including both personal protective equipment and monitoring equipment;
- calibrating monitoring equipment on a daily basis and recording results in field logs;
- ensuring that monitoring equipment is operating correctly, and providing maintenance when required;
- making recommendations to change protection levels of personal protective equipment (PPE);
- implementing proper decontamination and emergency procedures;
- defining work zones;
- conducting on-site health and safety meetings before on-site activities begin;
- ensuring on-site personnel have read the HS Plan and signed an acknowledgement form;
- authorizing stop-work, which will be executed upon determination of an imminent safety hazards emergency situation, or other potentially dangerous situations; and
- initiating and implementing changes to the HS Plan.

3.8 Contractor Responsibilities

Personnel performing work on-site are responsible for compliance with applicable federal, state, and local health and safety statutes, ordinances, and regulations. Each contractor shall prepare and conform to a health and safety plan, which provides planning at least as stringent as this HS Plan. Each contractor must identify a lead individual responsible for the health and safety compliance of its personnel, lower-tier subcontractors, and consultants. This person will be responsible for reporting to the HSC and for demonstrating compliance with the health and safety procedures.

In conformance with the Department of Labor, OSHA Hazardous Waste site Operations (29 CFR 1910.120), personnel proposed for on-site activities must participate in a medical monitoring program, as described in Section 11.0, must be certified for hazardous waste field work by a licensed physician, and must have successfully completed the required health and safety training.

3.9 Visitors

Authorized visitors to any work location on the site will be briefed on the hazards present at that location by the SSO. Visitors will be escorted while visiting the work location and will be responsible for compliance with the requirements specified in the HS Plan.

3.10 Record Keeping Responsibilities

It will be the duty of the SSO to develop and maintain the following records:

- verification of site-specific training;
- equipment maintenance and calibration logs;
- personnel/visitor logs;
- implementation of dust controls;
- dust monitoring results;
- verification of medical surveillance participation; and
- field change requests.

4.0 HAZARD EVALUATION

4.1 General

This section presents chemical and physical hazard information to be used for the development of health and safety protocols for on-site activities. The goals of the hazard evaluation are twofold. 1) to summarize available chemical information and the corresponding impacts on worker health and safety; and 2) to adequately describe the physical hazards associated with the site. This information is important in the development of action levels to be used for the determination of levels of respiratory and dermal protection. The use of real-time dust monitoring instruments in conjunction with the judgment of the SSO, will provide the basis for upgrading or downgrading levels of protection. The main constituent of concern at the site is PCB, which may be present in the soils of the site.

4.2 Field Activities

A number of field activities that may be performed during the action include following:

- excavation of soil and debris;
- construction of erosion and sediment control measures;
- installation of geosynthetic materials;;
- soil placement;
- loading of debris for off-site disposal; and/or
- seeding and revegetation.

The hazards associated with these activities include physical hazards from heavy equipment, vehicular traffic, falling objects, and noise. The main chemical hazards are associated with dermal contact with and inhalation of chemicals of concern. These tasks will be initiated using Level D protection.

4.3 Chemical Hazards

There is a potential for field personnel to be exposed to chemical hazards. The primary pathway for exposure to occur is dermal contact with chemicals of concern potentially associated with soils. Secondary pathways for exposure include inhalation of particulate materials and possible ingestion if personal hygiene is inadequate. Table 1 lists known exposure limits for chemicals that may be encountered at the site. Appendix B presents additional information on health effects from exposure to these chemicals.

4.3.1 Exposure via Ingestion

Exposure via ingestion can be prevented using the following guidelines:

- prohibiting eating, drinking, smoking, and the application of cosmetics in the work area; and
- requiring workers to wash hands and face prior to consuming food, beverages, or smoking.

4.3.2 Exposure via Dermal Contact

Exposure via dermal contact can be prevented using PPE and caution taken in handling liquids and solids in the work zone. The level of PPE required is described in Section 8.3. It is important that a common sense approach be taken in preventing dermal contact. Precautions should be taken to prevent touching unprotected portions of the skin (particularly eyes, nose or mouth) when handling liquids or solids in the work zone.

4.3.3 Exposure via Inhalation

Practices to be employed to minimize potential airborne exposure when performing these activities should include:

- standing upwind of the field activity;
- recognizing potential warning properties of chemicals and of dust that may be present during field activities (e.g., odor, irritation, nausea, etc.); and
- wearing appropriate PPE including respiratory protection directed by the SSO.

The SSO will be responsible for assessing the construction work areas for dust that could possibly present exposure via inhalation. Dust control techniques, such as low volume water spraying or fogging, may be required to minimize the potential for inhalation of particulates. In the unlikely event that dust cannot be controlled as described in Section 6.4 and the dust is above the action limits described in Sections 7.3, personnel will be required to wear NIOSH approved respiratory protection equipped with combination organic vapor and High Efficiency Particulate Air (HEPA) filter cartridges.

4.4 Physical Hazard Review

Physical safety hazards are inherent at any site and can include slips, falls, or sprains. It is the responsibility of the contractor's personnel to follow applicable regulations as well as the requirements outlined in this HS Plan to reduce accidents and injuries. The following physical hazards must be recognized and controlled during field activities:

- operation of heavy equipment;
- heat stress;
- noise;
- manual lifting;
- slip, trip and fall;
- falling objects;
- electrical equipment; and
- trenching excavation.

4.4.1 Operation of Heavy Equipment

Precautions must be taken when working around heavy equipment. The moving of the equipment from location to location is of particular concern. Equipment operators must obey site-specific safety requirements.

Except where electrical distribution and transmission lines have been de-energized and visibly grounded, heavy equipment will be operated near power lines in accordance with the guidelines specified in 29 CFR 1926.

4.4.2 Confined Space Entry

Workplaces that are not intended for human occupancy are defined as confined spaces. Limited openings hinder proper ventilation, escape, and rescue; therefore, creating a potentially life threatening situation for a worker.

Confined space entry is not anticipated for this project. However, if confined space entry is required, it will not be undertaken without prior approval from the Construction Manager, HSC and SSO. Any confined space entry will be governed by the proposed OSHA regulation, 29 CFR 1910.146.

4.4.3 Heat Stress

High ambient temperature can result in health effects ranging from transient heat fatigue, physical discomfort, reduced efficiency, personal injury, increased accident probability, to serious illness or death. Heat stress is of particular concern when personal protective clothing¹ is worn, since these garments prevent evaporative body cooling. Wearing personal protective equipment puts a worker at considerable risk of developing heat stress.

Individual physical conditioning, pre-existing illnesses, and use of alcohol contribute significantly to the potential for heat stress. In order to minimize the potential for heat stress several precautions should be taken:

- potable water should be readily available to personnel to replenish lost fluids;
- personnel should take frequent rest periods in shaded areas to minimize fatigue and exposure; and
- the SSO should monitor personnel for the signs of heat exhaustion or heat stroke.

Heat stress is caused by a number of interacting factors, including environmental conditions, clothing, workload, and the individual characteristics of the worker. Because heat stress is probably one of the most common (and potentially serious) illnesses at sites, regular monitoring and other preventive measures are vital.

Heat stress manifests in progressive stages, increasing in severity. The initial stage is commonly termed heat fatigue, which is usually transient, and subsides with rest and replenishment of fluids. Heat fatigue is characterized by discomfort, and reduced mental awareness, with a greater effect in workers not acclimated. Medical treatment is usually not needed.

Heat exhaustion can result from sustained exertion in heat, combined with failure to replace water and salts lost in sweat. Symptoms include fatigue, nausea, headache, and clammy, moist skin, which may be flushed or pale. Replacement of water and salts is required for recovery; victims may faint upon standing. Electrolyte replacement fluids should be taken until urine volume increases.

¹ Note: Chemical protective clothing is defined as, but not limited to: Clothing constructed of Tyvek, or coated-Tyvek, PVC rain suits or coveralls, and CPF Series Coveralls.

Heat syncope can result in fainting and is caused by standing immobile in heat. It is caused by pooling of venous blood in the dilated vessels of the skin and lower body. Recovery is complete and rapid following rest in a recumbent position at a cool location.

The most serious heat illness is heat stroke. Heat stroke is a **MEDICAL EMERGENCY**, treatment must be immediate, and professional medical attention must be obtained. Heat stroke is caused by a combination of factors including heavy exertion in heat, inadequate replacement of fluids, poor physical condition, and individual susceptibility. Failure of the sweat response occurs, leading to a rapidly accelerated increase in core temperature. The victim usually has hot, dry red skin, and if conscious, is confused; convulsions may be present. The victim must be cooled immediately. Heat stroke is fatal if treatment is incomplete or delayed.

As with any illness, the best cure is prevention. Heat stress is most likely early in the summer, prior to acclimatization. Full acclimatization takes from 5 to 7 consecutive days of controlled exertion in heat.

4.4.3.1 Operational Guidance

Determine a baseline heart rate for each person prior to on-site activities by counting the radial pulse. A work/rest schedule should be developed prior to initiating field activities, whenever ambient temperatures are greater than 70 degrees Fahrenheit (° F) and chemical protective clothing is used; and when temperatures are greater than 85° F without chemical protective garments (Table 2). The schedule must be constantly assessed to ensure effectiveness, and may need to be modified during the workday. Note that personnel performing physically more demanding work may need to establish a more restrictive schedule.

Increasing Work Rate

1. If a worker's heart rate does not increase, or increases only slightly (10% or less for the heart rate) from the baseline readings after the first work cycle, the work period (according to the established work-rest regimen) can be increased by 20%.
2. The worker shall be monitored closely after the next work cycle period and if there are still no significant increases in heart rate, the work period can be increased by an additional 10% and the rest period remains the same.
3. Increases in the work period can be made throughout the shift if there are no significant increases in the physiological monitoring indices.
4. Note that the increases to the work period are made based on the work-rest regimen established prior to initiation of work activities.

Decreasing Work Rate

1. Count the radial pulse as early as possible in the rest period.
2. If a worker's heart rate exceeds 110 beats per minute immediately after a work period, shorten the next work cycle by 30% and keep the rest period the same.
3. If the heart rate still exceeds the 110 beats per minute after the next work period, shorten the following work cycle by 30%.
4. Continue to shorten the personnel's work cycle until the heartbeat is below 110 beats per minute.

Adequate liquids must be provided to replace lost body fluids. Personnel must replace water and salt lost from sweating. Personnel must be encouraged to drink more than the amount required to satisfy thirst. Thirst satisfaction is not an accurate indicator of adequate salt and fluid replacement.

Replacement fluids can be a 0.1% salt-water solution, a commercial mix, such as Gatorade or Quik Kick, or a combination of these with fresh water. Personnel should be encouraged to salt their foods more heavily. Salt pills are prohibited.

The replacement fluid temperature should be kept cool. Cooling devices such as vortex tubes or cooling vests can be worn beneath protective garments. Breaks are to be taken in a cool, shaded rest area (<80° F). Personnel shall remove chemical protective garments during rest periods. Personnel shall not be assigned other tasks during rest periods. Personnel shall be informed of the importance of adequate rest and proper diet in the prevention of heat stress. Personnel shall be informed of the harmful effects of excessive alcohol consumption in the prevention of heat stress.

Individuals with pre-existing medical conditions or restrictions contraindicating exposure to elevated environmental heat are precluded from assignments that involve exposure to high temperatures. Healthy individuals will vary significantly in their tolerance to heat, and heat tolerance can be affected by minor illnesses (cold, flu) and by prescription and over-the-counter medications. The heart rate measure is only a part of the overall situation to be considered; other objective, and subjective symptoms of heat stress, such as: extreme fatigue, nausea, disorientation, light-headedness, and breathlessness must be fully considered when evaluating the adequacy of control measures. The heart rate measure will provide guidance that can be significantly different for each member of a field team based on their acclimatization, physical

fitness, and heat tolerance. If it is critical that team members use the same work/break schedule, the schedule that accommodates the least heat-tolerant team member shall be observed.

Training

Those personnel (including workers, supervisors, and contractor personnel) potentially exposed to heat stress conditions shall have been trained in the following:

1. sources of heat stress, influence of protective clothing, and importance of acclimatization;
2. how the body handles heat;
3. heat related illnesses;
4. preventative/corrective measures; and
5. first aid procedures.

4.4.4 Cold Stress

Critical factors in preventing cold stress disorders are adequate clothing and staying dry. The SSO and Construction Manager will ensure the capability to quickly move individuals who become wet to a sheltered, warm area. The following specific steps will be taken [adapted from the ACGIH TLV booklet (ACGIH 1999)].

- If ambient temperatures are 40° F or below, site training will include prevention of cold injury, cold-injury symptoms, and cold-injury first aid.
- If ambient temperatures are 40° F or below, and there is a potential for workers to become significantly wet (splashed or soaked), the SSO will ensure that at least one of the following controls is in place:
 - a sufficient supply of dry, warm clothing is immediately available;
 - personnel wear clothing appropriate for water contact (e.g., immersion-survival suits, neoprene chest waders, wet suit,); or
 - a heated break area is immediately available.
- A heated break area will be provided if ambient temperatures are below 32° F.
- At a minimum, breaks will be taken in a warm area every 120 minutes if ambient temperatures are below 32° F.
- Workers will be allowed to take unscheduled breaks, if needed, in a warm area.
- If the equivalent chill temperature (temperature combined with the effect of wind) is less than -29° F, outdoor work will be discontinued or effective engineering controls such as windscreens, temporary shelters, or portable heating units will be used.

4.4.5 Noise

Hearing protection may be required for certain job tasks. If necessary, the SSO will monitor noise levels to determine if hearing protection is required. Training on the proper use of hearing protection will be conducted as a part of the health and safety briefing conducted by the SSO prior to on-site work.

4.4.6 Manual Lifting

Activities may require personnel to move large, heavy objects by hand. The human body is subject to severe damage in the forms of back injury and hernia if caution is not observed when handling, lifting, or moving these large, heavy objects.

General Rules

- Get a good footing.
- Place feet about one shoulder width apart.
- Bend at knees to grasp weight.
- Keep the back straight.
- Get a firm hold.

4.4.7 Slip, Trip and Fall Hazards

Walkways should be maintained, clear of debris and in a dry condition. Tools and clothing should be stored when not in use and should not be left on the ground.

4.4.8 Electrical Equipment

Extension cords used with portable electric tools and appliances shall be three-wire and grounded. Plugs shall conform to the type and configuration required by the OSHA Construction Standards.

4.4.9 Trenching/Excavation

Trenching/excavation activities will be carried out in accordance with the contractor's approved Trenching and Excavation Safety Procedure.

4.4.10 Falling Objects

During clearing and grubbing activities, any area where trees or branches are to be felled should be evacuated prior to commencing activities. A radius of 1.5 times the height of the tree should be cleared of personnel prior to commencing.

4.5 Biological Hazard

4.5.1 Insect Bites and Stings

Insects may be present at this site. Although they can be painful, they rarely cause death. However, some people have a severe allergic reaction to an insect bite or sting that can result in a life threatening condition. The following is a list of preventive measures:

- apply insect repellent prior to fieldwork and or as often as needed throughout the work shift;
- wear proper protective clothing (work boots, socks and light colored pants);
- when walking in wooded areas, avoid contact with bushes, tall grass, or brush as much as possible;
- field personnel who may have insect allergies should provide this information to the HSO prior to commencing work; and
- mark and avoid fire ant mounds.

4.5.2 Tick Bites

The Center for Disease Control (CDC) has noted the increase of Lyme Disease and Rocky Mountain Spotted Fever (RMSF) resulting from bites from infected ticks that live in and near wooded areas, tall grass, and brush. Ticks are small, ranging in size up to about one quarter inch. They are sometimes difficult to see. The tick season extends from spring through summer. When embedded in the skin, they may look like a freckle. Lyme disease has occurred in 43 states, with the heaviest concentrations in the Northeast (Connecticut, Massachusetts, New Jersey, New York, Pennsylvania), the upper Midwest (Minnesota and Wisconsin), and along the northern California coast. It is caused by deer ticks and the lone star ticks which have become infected with spirochetes. Deer ticks may range in size from one-eighth inch in size up to one-quarter inch in size and can be black or brick red in color. Lone star ticks are larger and chestnut brown in color.

RMSF has occurred in 36 states, with the heaviest concentrations in Oklahoma, North Carolina, South Carolina, and Virginia. It is caused by Rocky Mountain wood ticks, and dog ticks which have become infected with rickettsia. Both types of ticks are black in color.

Standard field gear (work boots, socks and light-colored coveralls) provides good protection against tick bites, particularly if the joints are taped. However, even when wearing field gear, the following precautions should be taken when working in areas that might be infested with ticks:

- when in the field, check yourself often for ticks, particularly on your lower legs and areas covered with hair. Look for "a freckle that moves";
- spray outer clothing, particularly your pant legs and socks, **BUT NOT YOUR SKIN**, with an insect repellent;
- when walking in wooded areas, avoid contact with bushes, tall grass, or brush as much as possible;
- if you suspect that a tick is present, remove it with tweezers only, and not with matches or a lit cigarette. Grasp the tick with the tweezers and pull gently. If it resists, cover the tick with salad oil for about 15 minutes to asphyxiate it, then remove it with tweezers. Do not use nail polish or any other type of chemical. Be sure and remove all parts of the tick's body. Once removed, disinfect the area with alcohol, or a similar antiseptic;
- look for signs of the onset of Lyme disease, such as a rash that looks like a bulls-eye or an expanding red circle surrounding a light area on the skin, frequently with a small welt in the center. This rash can appear from several days to several weeks after the tick bite; and
- also, look for signs of the onset of RMSF, an inflammation, or rash comprising many red spots under the skin, which appears 3 to 10 days after the tick bite. The rash frequently occurs on the ankles and wrists.

The first symptoms of either disease are flu-like chills, headache, dizziness, fatigue, stiff neck, and bone pain. If immediately treated by a physician, most individuals recover fully in a short period. If not treated, symptoms that are more serious can occur.

If you believe you have been bitten by a tick, or if any of the signs and symptoms noted above appear, contact the SSO. The SSO is to have the authority to authorize a physician visit for an examination and possible treatment.

4.5.3 Snake Bites

There are poisonous snakes in Calhoun County, Alabama. If bitten by a snake, remain calm, keep the affected area below the level of the heart and walk, do not run, to the nearest aid station for assistance. The SSO will designate someone to immediately transport the victim to the closest medical facility for treatment or send for appropriate medical assistance, whichever is faster. The following precautions should be used when working in areas with snakes:

- wear appropriate protective equipment (work boots, snake chaps);
- be alert and aware of surroundings; and
- avoid walking in wooded areas and through bushes, tall grass, or brush as much as possible.

4.5.4 Plants

The potential for contact with poisonous plants exists when performing fieldwork in Alabama. Poison ivy, sumac, and oak may be present on site. Poison ivy can be found as vines on tree trunks or as upright bushes. Poison ivy consists of three leaflets with notched edges. Two-leaflets form a pair on opposite sides of the stalk, and the third leaflet stands by itself at the tip. Poison ivy is red in the early spring and turns shiny green later in the spring. Poison sumac can be present in the form of a flat-topped shrub or tree. It has fern-like leaves, which are velvety dark green on top and pale underneath. The branches of immature trees have a velvety "down". Poison sumac has white, "hairy" berry clusters. Contact with poison ivy, sumac or oak may lead to a skin rash, characterized by reddened, itchy, blistering skin which needs first aid treatment.

Poison ivy barrier creme and cleanser will be used at the discretion of the SSO. Site workers will apply the barrier creme prior to working in areas where exposure to the poisonous plants exists. Subsequently, the cleanser will be used at the end of the work shift to remove oils, which remain on the skin from exposure to the plants.

5.0 TRAINING REQUIREMENTS

5.1 Basic Training

Consistent with 29 CFR 1910.120, OSHA Hazardous Waste Operations, personnel performing fieldwork associated with the activities must have received formal off-site hazardous waste training (with three days on-the-job training) prior to on-site work. This consists of 40 hours of initial training and 8 hours of annual refresher training for field staff. Managers and supervisors must receive an additional 8 hours of specialized off-site training geared toward their supervisory responsibilities. Excluded from this responsibility are workers, such as truck drivers, who will not have the opportunity to contact site hazards. Additionally, personnel responsible for field activities must be familiar with and have access to this HS Plan.

5.2 Pre-Work Briefing

A health and safety meeting will be conducted by the SSO prior to commencing field activities. These meetings will be held weekly during the course of the field activities. The meeting will address the following topics:

- contents of the approved HS Plan;
- discussion of work tasks and potential hazards;
- identification of evacuation routes and routes to the hospital;
- locations of site emergency equipment and supplies;
- discussion of personal protective equipment (PPE) requirements and action levels;
- review of the OSHA 101 form (Appendix C) to be filled out in the event of an injury or illness caused by work at the site; and
- reminder that unsafe work practices or conditions should be reported to the SSO.

Health and safety site-specific training will also be conducted for visitors prior to entering the site and to any new personnel assigned to the site. Following the briefing, personnel will be required to signify that they have read and understood the contents of this HS Plan, by signing the Health and Safety Plan Signature Form found in Appendix D.

5.3 Daily Briefings

At the beginning of each day, the SSO (or designee) will review on-site work activities and outline site conditions with respect to modifications of work plans and health and safety plans. Personnel will be briefed and updated on any changes in safety procedures and sign a "Tailgate" Safety Meeting Form found in Appendix E.

5.4 First Aid and CPR

The SSO will identify those individuals having First Aid and CPR training. Training will be consistent with the requirements of the American Red Cross. Two construction personnel will be First Aid and CPR trained.

5.5 Documentation

Documentation of training requirements is the responsibility of each employer. Written documentation verifying compliance with 29 CFR 1910.120 must be submitted to the SSO. Documentation of workers current training credentials (40-Hour Training, 8-Hour Refreshers, 8-Hour Supervisory Training and medical respirator clearance) will be kept on-site and submitted to the Solutia representative on request. No one will be allowed to work on-site without the appropriate training and medical clearances.

5.6 Hazard Communication

In accordance with the OSHA Hazard Communication Standard (29 CFR 1920.1200 and 29 CFR 1926.59), copies of material safety data sheets (MSDS) for chemical materials brought on-site will be available in the field office or from the SSO. The MSDS training will be conducted by the SSO in accordance with 20 CFR 1920.1200 and 29 CFR 1926.59 and the contractor's hazard communication program. Training will include, but may not be limited to hazards or potential hazards associated with any chemical materials on-site. Appendix B contains the MSDSs for on-site hazardous materials.

6.0 SITE CONTROL PROCEDURES

6.1 Site Entry And Exit

Contractor's personnel and visitors will sign in daily according to requirements for the site and will be initially briefed on the HS Plan guidelines and task-specific requirements by the SSO (or designee). Area access will be controlled with appropriate caution tape and signs to restrict access.

6.2 Daily Start Up

The following procedures will be followed prior to daily start up:

- The SSO (or designee) will review work activities with respect to modifications of the work plans and health and safety plans, and brief and update personnel;
- Safety and monitoring equipment will be checked for proper function; and
- When warranted, as described in Section 7.2, the SSO will establish dust monitoring background concentrations at a location upwind from the active operations area. Deviations in real-time instrument readings during site activities will trigger a recheck of the upwind background concentrations to verify the source of the readings.

Start-up activities shall be documented in the site logbook.

6.3 Area Operations

In the case where contaminated materials must be disturbed or handled, site control measures will be instituted. The primary means of maintaining site control and reducing migration of contaminated materials into uncontaminated areas will be by designating work zones. Work zones serve to limit contaminated area access, contain gross contamination, provide work zone security, and place a buffer zone between the potentially contaminated area and the rest of the site, if needed.

The following zones will be established for each task of the project:

- Exclusion Zone;
- Contamination Reduction Zone; and
- Support Zone.

The exclusion zone includes those areas that are considered contaminated, potentially contaminated, or could become contaminated during the work activity. Exclusion zones will be

delineated at the beginning of site activities to secure the area against unauthorized personnel. Once these contaminated or potentially contaminated areas are defined, a buffer zone will be added to enhance safety. The exclusion zone will be delineated using temporary fencing or other means to maintain access control of the area. Unauthorized personnel will not be permitted to enter the exclusion zone. Access and egress to the exclusion zone will be controlled through defined entrance/exit points. Entering and leaving an exclusion zone will be controlled by the SSO. Activities within this established zone will be conducted prior to removing control barriers.

The contamination reduction zone (CRZ) will be designed to limit contamination from leaving the exclusion zone. Access control points to both the exclusion zone (and any support zones) will be maintained. The CRZ provides a space for the decontamination of personnel and equipment and provides an area to assist the work parties (respirator cartridge exchange, equipment staging). The heavy equipment and personnel decontamination processes are outlined in Section 9.

The support zone will be the area furthest away from any contaminated or potentially contaminated substances. It is where the command post will be located and support activities occur. Project health and safety equipment will be stored in the support zone and be available for use.

6.4 Dust Control

One of the best ways to reduce exposure to potentially contaminated soils is by reducing the generation of dust. Equipment operators will be responsible for using their equipment in a method that will create the least amount of unnecessary soil disturbance. This will include speed reduction during travel and correct loading/unloading of contaminated soil during work operations. If dust generation becomes a problem because of wind, low rainfall, etc., the Construction Manager and the SSO will be responsible for implementing fugitive dust control measures.

7.0 DUST MONITORING REQUIREMENTS

7.1 General

Dust controls as described in Section 6.4 will be implemented to minimize dusty conditions. Monitoring for dust will be required in accordance with the Dust Control Plan for this project. Air quality monitoring is not anticipated during construction response activities because the chemicals listed in Table 1 are not volatile under normal outdoor conditions. Dust monitoring does not include the collection of samples for laboratory analysis.

7.2 Real-Time Monitoring

At the direction of the SSO based on the Dust Control Plan, real-time monitoring for dust will be conducted during construction activities. When required, monitoring will be performed in the breathing zone of personnel performing work in dusty conditions and at the downwind edge of the property where construction activities are being performed. Any instrument readings above background concentrations will be compared to the established action levels presented in Section 7.3 to maintain the appropriate level of respiratory protection for personnel. Dust monitoring involves real-time monitoring of solid particulates in the air.

The SSO will first establish dust monitoring background concentrations at a location upwind from the construction operations area. During dusty conditions, breathing zone and downwind perimeter dust monitoring will be performed every 15 minutes. In the unlikely event that dust controls are unsuccessful and dust in the breathing zone is above the action level presented in Section 7.3, then the PPE requirements will be upgraded to Level C. If dust monitoring at the perimeter indicates dust above the action levels presented in Section 7.3, the SSO will determine if activities should be halted to eliminate nuisance dust beyond the property. Once implemented, dust monitoring may cease when four consecutive dust readings are below the action limits presented in Section 7.3 or when work creating the dusty conditions stops. Deviations in real-time instrument readings during site activities will trigger a recheck of the upwind background concentrations to verify the source of the readings. Real-time readings will be documented on a Dust Monitoring Data Sheet found in Appendix F.

The Miniram, or equivalent, will be used to monitor for dust. The Miniram will be checked daily prior to initiating work activities, in accordance with the Miniram Standard Operating Procedures provided in Appendix G. Instrument checks are to be entered in the site logbook at the beginning

of the workday and every eight hours of use thereafter. A spare instrument will be available to minimize lost work time in the event real-time air monitoring equipment becomes inoperable and requires maintenance or repair.

7.3 Dust Action Levels

In general, the initial level of respiratory protection will be maintained until the SSO determines that real-time dust monitoring data should be collected and the dust readings are above the established action levels. For the duration of the task, the dust concentrations shall determine the level of respiratory required.

The following real-time, breathing-zone dust concentration action levels provide guidelines for determining the level of respiratory protection appropriate for each task: (also presented in Table 3).

Breathing Zone Action Limits

Dust levels will be monitored in the breathing zone of personnel performing work in dusty conditions. Readings will be applied to the following action levels:

- $< 5.0 \text{ mg/m}^3$ - Continue work in Level D PPE;
- $> 5.0 \text{ mg/m}^3$ - Continue work in Level C PPE; and
- $> 50.0 \text{ mg/m}^3$ - Stop work.

Downwind Perimeter Action Limits

Dust levels will be monitored at the downwind perimeter of the property where construction activities are being performed during dusty conditions. Readings will be applied to the following action levels:

- $< 1.0 \text{ mg/m}^3$ - Continue work;
- $> 1.0 \text{ mg/m}^3$ - SSO will determine if work should cease; and
- $> 5.0 \text{ mg/m}^3$ - Stop work.

8.0 WORK TASKS AND PERSONAL PROTECTIVE EQUIPMENT REQUIREMENTS

8.1 General

The level of protection required for each area involving field activities will be based on the recognized hazards of the chemicals of potential concern, most likely routes of exposure (e.g., dermal, ingestion and possibly inhalation) and on monitoring and action levels determined from hazard evaluation of the chemicals of concern. The purpose of PPE is to ensure that the individual is protected from the hazards encountered in the course of the project. The elements involved in PPE include protective clothing, eye and face protection, and respiratory protection that should be used by individuals involved in sampling field activities.

8.2 Respiratory Protection Program

Personnel required to wear a respirator must comply with the requirements outlined in this program. Personnel who will be involved with site activities must first be cleared by the HSO. These personnel must also have been trained in the selection, operation, and maintenance of air purifying and supplied air respirators in accordance with OSHA Standard 29 CFR 1910.134. Upgrade to level C will be required if dust monitoring action levels are exceeded. The NIOSH Respirator Decision Logic will be used to determine appropriate respiratory protection.

Prior to using a respirator, personnel must be properly fit tested. The fit test will be conducted by the HSC if proof of a previous fit test has not been documented within the last year. The fit test will be performed using the appropriate challenge aerosol for the type of respirator selected (e.g., irritant smoke, isoamyl acetate (e.g., banana oil or saccharin aerosol)). Records of fit tests will be maintained in project files and with the HSC.

Special lens holders, glasses, or both may be required for full-face respirators. Persons requiring corrective lenses and a full-face respirator shall have a specific respirator fitted with the corrective lens prescription prior to the initiation of field activities. Contact lenses shall not be worn while performing fieldwork. Beards, long sideburns, and mustaches interfere with the proper fit of a respirator and therefore are prohibited.

A respirator will be assigned to each person who may have to use one during field activities. It is the individual's responsibility to properly operate and maintain the respirator. Personnel will be

responsible for cleaning, disinfecting, inspecting, and storing respirators before and after each use. Personnel will report any problems with respirators to the HSC. For self-contained breathing apparatus (SCBA) or airline respirators, only compressed air, with a quality rating of Grade D or better, will be used as the source of breathing air. SCBA or airline respirators are not currently anticipated to be required for this project.

8.3 PPE Protection Summary

A description of minimum requirements for Level C and Level D protection is summarized below. When using Level C criteria, the buddy system must be used; at least two persons must conduct the work. Planned field activities will be initiated at Level D protection. The HSC will decide if an upgrade to Level C is necessary due to airborne dust. If PPE above Level C is deemed necessary, then field activities will cease pending assessment by the HSC and HSO.

8.3.1 Level D Equipment

- boots with steel toes and shank;
- Tyvek® coveralls;
- Neoprene® or Nitrile® chemical resistant outer gloves (optional - at the determination of the SSO);
- disposable latex inner gloves;
- boot covers (disposable - at the determination of the SSO);
- safety glasses (face shield and/or goggles when needed for chemical splash protection such as in the plant area);
- hard hat (optional - at the determination of the SSO or when required by Solutia);
- thermal/weather protection (coat, overalls, sweater, hat, rain gear, cool vest, heat stress monitors, optional - at the determination of the SSO or by personal choice);
- ear protection to be worn when working around drill rigs and other loud equipment; and
- long sleeve shirt and long pants.

8.3.2 Level C Equipment

- minimum half-face air purifying respirator (NIOSH approved) equipped with a HEPA filter cartridge for dust;
- Tyvek® coveralls;
- safety boots with steel toe & shank;
- Nitrile® or Neoprene® chemical resistant outer gloves (optional - at the determination of the SSO);
- disposable latex inner gloves;
- boot covers (optional - at the determination of the SSO);

- hard hat (optional - at the determination of the SSO or when required by Solutia);
- face shield and/or goggles when needed for chemical splash protection (optional - at the determination of the SSO);
- thermal/weather protection (optional - at the determination of the SSO);
- ear protection to be worn when working around loud equipment; and
- long sleeve shirt and long pants.

Modifications in the personal protective equipment requirements outlined in this document may be necessary as new conditions and/or tasks warrant. Addenda and revisions to this health and safety plan will be made only by the SSO, the HSC or the HSO, and shall be documented using the Addendum/Revision Record found in Appendix A.

9.0 DECONTAMINATION PROCEDURES

9.1 General

Decontamination procedures reduce the potential for transport of chemicals of concern outside of the work area. Decontamination procedures also protect workers from potential exposure, which may occur during removal of personal protective equipment. It is important that decontamination is handled in an organized, step-wise manner. If decontamination is conducted improperly, inhalation or dermal contact with constituents of concern may occur.

Decontamination consists of thoroughly decontaminating reusable PPE and general equipment, and washing face and hands before leaving the site. Disposal of wastes generated from decontamination procedures will be the responsibility of Solutia.

9.2 Contamination Prevention

The prevention of contamination is the first step towards providing a clean and safe work place. Contamination prevention should minimize worker exposure and help ensure valid sample results by precluding cross-contamination. Procedures for contamination avoidance include:

Personnel

- Do not walk through areas of obvious or known contamination; walking through puddles or mud, and kneeling on the ground shall be avoided.
- Make sure personal protective equipment has no cuts or tears prior to wearing.
- Fasten closures on suits.
- Particular care should be taken to protect any skin injuries.
- Stay upwind of dust.

Equipment and Samples

- Monitoring equipment shall not be placed on potentially contaminated surfaces.
- Limit the amount of contamination that comes in contact with heavy equipment and vehicles.
- If contaminated tools are to be placed on non-contaminated equipment/vehicles for transport to the decontamination area, use plastic to keep the equipment clean.

9.3 Decontamination Equipment

The following materials will be available for decontamination as needed:

- galvanized wash tub;
- tap water;
- alkaline soap solution (Alconox®, or other heavy-duty detergent);
- long handle scrub brushes;
- disposable plastic to cover the station area;
- disinfectant wipes to clean inside of respirator; and
- distilled water in a squeeze bottle for rinsing.

9.4 Personal Decontamination

Diagrams of general work areas and outlines for Level C and Level D decontamination are presented on Figures 2 and 3, respectively. The following minimum procedures for Level C decontamination will be followed prior to leaving the work area:

Exiting Exclusion Zone

Equipment drop

1. Upon exiting the exclusion or work zone, workers will deposit their equipment on a plastic drop cloth in the designated area. Soil and sediment sampling equipment will be wiped clean with a damp cloth, as required. During hot weather, a cool-down station may be set up in this area.

Contamination Reduction Zone

Outer Garment, Boots, and Gloves
Wash and Rinse

2. Workers will scrub outer boots, outer gloves, and coveralls with a long handled brush and soap and water. Workers will then rinse with plenty of water.

Outer Boot and Glove Removal

3. Once completed with rinsing, workers will remove outer gloves and outer boots and discard them.

Air Purifying Respirator

4. Workers will receive a new respirator cartridge (or mask), outer gloves, and outer boots for return to the work/exclusion zone.

Outer Garment Removal

5. If workers are not returning to the work/exclusion zone, they will remove their coveralls and deposit them in separate containers.

Respirator Removal

6. Once coveralls are deposited, respirators may be removed. Respirators will be washed in soap solution and rinsed in water. The inside of the respirators will be cleaned with an alcohol wipe. Inner gloves will be removed and discarded.

Support Zone

Field Wash

7. Thoroughly wash hands and face. Shower as soon as possible.

During, this procedure, methods for properly disposable or contaminated reusable personal protective clothing or equipment must be followed to reduce the possibility of contacting potentially contaminated media. Decontaminated PPE and trash will be placed in DOT-approved drums or roll-offs for disposal.

9.5 Equipment Decontamination

9.5.1 Monitoring Equipment

Measures shall be taken by personnel to prevent the contamination of monitoring equipment used on the site. Once contaminated, instruments are difficult to clean without damaging them. Any delicate instrument, such as monitoring equipment, that cannot be decontaminated easily, should be protected while it is being used by placing it in a bag and using tape to secure the bag around the instrument. This should also be performed during periods of inclement weather, since moisture can affect instrument performance. Openings in the bag can be made for sample intake and exhaust.

9.5.2 Respiratory Protective Equipment

When respiratory protective equipment is required, there is a high potential for these units to become contaminated. At the end of each workday, respirators will be thoroughly decontaminated. During decontamination, this equipment will be properly disassembled (according to manufacturer specifications), washed with soap and water, rinsed in water, cleaned with an alcohol wipe and allowed to dry before reassembly. Disassembly and reassembly shall only be performed by personnel trained in this task.

9.5.3 Excavation Equipment

At the discretion of the SSO, decontamination procedures may be used on a daily basis to address potential contamination or equipment that will move between clean and contaminated areas without leaving the work area. Brushes and other similar tools will be used to manually remove gross materials from tires, tracks, and other portions of the equipment.

A steam cleaner may be used to decontaminate equipment at the completion of the project and for any equipment leaving the site from a contaminated work area. Personnel should exercise caution when using a steam cleaner. The high-pressure steam can cause severe burns. Protective gloves, safety glasses with side shields and face shield, hard hats, steel-toed boots, and Tyvek suits or rain gear will be worn when using the steam cleaners. Small equipment will be decontaminated as per procedures referenced in Section 9.3. Water from the decontamination process will be captured for appropriate disposal.

10.0 SAFETY CONSIDERATIONS AND ACCIDENT PREVENTION

10.1 Safety Considerations

Safety considerations are required by on-site workers for activities conducted at the site. The following general safety rules are to be observed at each work site.

PERSONNEL HEALTH AND SAFETY RULES

The following general safety rules are to be observed at project sites.

- At least one copy of this plan shall be available at each work area.
- Horseplay, practical joking, or any other actions that jeopardize safety will not be tolerated.
- Running is not permitted.
- Alcoholic beverages and non-medical drugs are not permitted at the site. Personnel suspected of being under the influence of alcohol or drugs will be removed from the site.
- Radios (except two-way radios), tape players or other forms of entertainment devices are prohibited in the authorized zone.
- Activities will be performed in such a manner to minimize or prevent the disbursement or release of contaminants.
- Contaminated protective equipment, such as respirators, hoses, boots, etc., shall not be removed from the regulated area until it has been cleaned, or properly packaged and labeled.
- Removal of contaminated soil from protective clothing or equipment by blowing, shaking or any other means, which may disperse contaminants into the air, is prohibited.
- Transportation and disposal of contaminated materials shall comply with applicable local, state, and federal regulations. These items will be addressed by the generator, transporter and disposer.
- Containers shall be moved only with the proper equipment and shall be secured to prevent dropping or loss of control during transport.
- Emergency equipment shall be located in readily accessible locations.
- Trenching, shoring, and excavation work must comply with federal OSHA rules.
- No food or beverages shall be present or consumed in the regulated area. No tobacco products shall be present or used, and cosmetics shall not be applied in the regulated area.
- Smoking will be permitted only in designated areas.
- Personnel shall be required to wash their hands and face before eating, drinking, smoking, or applying cosmetics.
- Portable or fixed emergency shower/eyewash stations shall be located outside the regulated area near work activities.
- Prompt remedial action shall be taken whenever an inadvertent release of a hazardous material occurs.
- Appropriate action to provide secure footing shall be taken at locations where personnel will be working.

- Provision must be made for cleaning gross contamination from boots and suits in the decontamination zone.
- Whenever solvents, cleaners, or other chemical substances are used for decontamination, properly completed MSDSs for the chemicals shall be available at the work area.
- Whenever flammable or combustible solvents are used for decontamination, specific procedures for the control of flammable gases and vapors may be necessary. When concentrations of flammable vapors cannot be controlled by ventilation, procedures would include, but are not limited to, the following:
 - tests shall be made by a qualified person to ensure that concentrations of flammable vapors in the work area do not exceed 20% of the lower explosive limit;
 - as appropriate, equipment on site shall be bonded and grounded, spark proof, and explosion resistant; and
 - an adequate supply of ABC fire extinguishers, shall be strategically located throughout the work area so as to limit the travel distance required by any worker to reach the extinguisher to less than 75 linear feet.
- A qualified person shall take positive steps to ensure that personnel are protected from physical hazards which would include, but are not limited to, the following:
 - discharge of steam, high pressure air, water or oil;
 - tools or other objects dropping from overhead;
 - falls from scaffolds, stairs, or ladders;
 - tripping over hoses, pipes, tools or equipment;
 - slipping on wet, oily surfaces;
 - insufficient or faulty personal protective equipment;
 - insufficient or faulty operations equipment and tools; and
 - noise in excess of acceptable levels.

10.2 Task Specific Accident Prevention

10.2.1 Personal Protective Equipment

Field personnel engaged in construction operations or other work activities where overhead hazards, as indicated by the SSO, are present, will wear approved hard hats. Personnel working around heavy equipment will be required to wear steel-toe safety shoes. At the area of operation personnel will wear eye protection. If elevated real-time dust levels are noted during construction activities, respiratory protection will be based on the action levels described in Section 7.3.

Personnel working at unguarded heights greater than 6 feet will be secured by safety belts and lifelines. The lifeline will be secured to a substantial anchorage. Safety belts, lifelines, and accessories will be inspected daily when in use and maintained in good conditions.

10.2.2 Work Practices

Good housekeeping conditions will be observed in and around the work area. Scrap, waste material, and other debris will be collected and stored in piles or containers for removal and disposal. Legible understandable precautionary labels shall be affixed prominently to these containers.

For above ground hazards, electrical lines will be identified. A minimum distance of 10 feet must be maintained between any equipment and any transmission lines 50 kilovolts (kV) or less. For lines greater than 50 kV, the required distance is 10 feet plus 0.4 inches for every 1 kV over 50 kV.

The location of safety equipment and evacuation procedures will be established prior to initiation of operations. The layout of construction support facilities is subject to approval of the SSO.

Construction Equipment

Operators will shut down heavy equipment engines before leaving the vicinity of the equipment. Construction operations will be terminated in the event of an electrical storm. Unattended trench areas must be adequately protected to prevent field personnel or other persons from stepping or falling into excavations.

Daily inspections will be conducted by operators prior to using equipment. This inspection will include a thorough check of the hydraulic hoses, connections, and valves. Deficiencies will be corrected or safe conditions will be verified before starting the equipment.

Construction equipment will not be moved backwards unless the driver has personally inspected the area behind him. Vehicles will be equipped with serviceable automatic backup alarms.

11.0 MEDICAL MONITORING REQUIREMENTS

11.1 Routine Examination

Contractor and subcontractor personnel involved in construction activities at the site are required to participate in a medical monitoring program consistent with OSHA 29 CFR 1910.120, Hazardous Waste Operations. On-site personnel are required to have medication examinations, prior to participation in on-site operations. These examinations will be conducted on at least a biennial basis. The exams shall consist of a medical and work history with special emphasis on symptoms related to exposure to hazardous substances, use of PPE, and exposure to temperature extremes.

11.2 Non-Routine Medical Examination

Nonscheduled medical examinations shall be conducted under the following circumstances:

- After known or suspected acute exposure to any toxic or hazardous material.
- At the discretion of Solutia, the Construction Manager, HSO, HSC and SSO, when an person is suspected of having been exposed to a significant level of toxic or hazardous material.
- At the discretion of Solutia, the Construction Manager, HSO, HSC, SSO and upon receipt of request for a medical examination from a person with demonstrated symptoms of exposure to hazardous substances.
- Prior to a person returning to work after a lost-time injury or illness.

12.0 EMERGENCY EQUIPMENT AND FIRST AID REQUIREMENTS

12.1 Communications

Two sets of communication systems will be established prior to initiating site activities: (1) internal communications among personnel on-site; and (2) external communication between on-site and off-site personnel. Internal communication alerts team members to emergencies, passes along safety information, time remaining until next rest period, changes in the work to be accomplished, and maintains site control. An external communication system between on-site and off-site personnel is necessary to report to management and to maintain contact with essential off-site emergency response personnel.

On-site internal communications will be conducted through verbal communications and/or hand-held two-way radios. Nonverbal communications will be used when background noise or PPE impede verbal communications and will utilize standard hand and air-horn signals.

On-site Communication Procedures

- If radios are used, channel one will be designated as the radio frequency for personnel in the Exclusion Zone. Other on-site communications will use channel two.
- If radios are used, personnel in the Exclusion Zone will remain in constant radio communication or within sight of the contractor's superintendent. Any failure of radio communication requires an evaluation of whether personnel should leave the Exclusion Zone.
- The following standard hand signals will be used in case of radio failure:
 - Hand gripping throat.....Out of air, cannot breathe.
 - Grip partner's wrist or both hands around waist. Leave area immediately.
 - Hands on top of headNeed assistance.
 - Thumbs upOK, I am all right, I understand.
 - Thumbs downNo, negative.
- **Intermittent five-second blast** is the emergency signal for a fire emergency and to indicate personnel should leave the Exclusion Zone.
- **Continuous thirty second blast** indicates a medical emergency and to indicate personnel should leave the Exclusion Zone.

Telephone communications will be established for emergency use. The location of the nearest phone will be given to site workers. A list of emergency telephone numbers (Section 12.7.1) along with a list of key personnel will be posted at each work area.

12.2 First Aid Emergency Equipment

Basic first aid and emergency equipment will be maintained in the support zone and/or the CRZ as appropriate. On-site personnel will have access to this equipment in the event of an injury or if an exposure to hazardous materials occurs. The various types of first aid and emergency equipment that will be available include:

- air horns;
- first aid kit;
- portable eye wash station;
- stretcher;
- splints;
- instant cold packs;
- ABC type fire extinguishers; and
- personal protective gear.

12.3 Personal Injury

First aid will be administered to injured personnel, as required, by persons certified to administer first aid and CPR. Individuals requiring transport to a hospital will be given emergency first aid on-site, if necessary, and will be transported to the Northeast Regional Medical Center by the local rescue squad. When possible, injured personnel will be decontaminated prior to transport to the hospital. In life threatening situations, however, the injured personnel will be wrapped in a sheet or similar barrier material and the contractor will notify the hospital emergency staff personnel to prepare them for handling contaminated personnel from the site.

12.4 General First Aid Procedures

General first aid procedures are included in this section. Typical responses may include:

- **Skin Contact:**
Use copious amounts of soap and water. Wash/rinse affected area thoroughly, then provide appropriate medical attention. An eyewash system will be provided on-site at the support zone as appropriate. Eyes should be rinsed for 15 minutes when chemical contamination has occurred.
- **Inhalation:**
Move the victim to fresh air immediately. If necessary, restore breathing. Decontaminate and transport to Northeast Regional Medical Center if required.

- **Ingestion:**
Decontaminate and transport the victim to emergency medical facility immediately.

12.5 Blood-Borne Pathogens

The blood-borne pathogens standard, 29 CFR 1910.1030, is designed to protect workers from exposure to the hepatitis B virus (HBV), the human immuno-deficiency virus (HIV) and other blood-borne pathogen. These viruses, as well as other organics that cause blood-borne diseases, are found in human blood and certain other human body fluids. In the event first aid/CPR is required, latex gloves and a rescue-breathing mouthpiece are to be used for personal protection from contact with blood or other potentially infectious materials.

12.6 Adverse Weather Conditions

In the event of adverse weather conditions, the SSO will determine if work can continue without jeopardizing the health and safety of any field workers. Items to be considered prior to determining if work should continue include:

- potential for heat stress and heat-related injuries,
- limited visibility;
- electrical storms;
- high winds; or
- torrential rains.

12.7 Emergency Information

Emergency telephone numbers for the surrounding area and the nearest equipped hospital have been identified and listed below. Figure 1 identifies the route to Northeast Regional Medical Center, located in Anniston. Emergency telephone numbers will be posted in the support zone of the site, along with the Hospital Route Map.

12.7.1 Emergency Phone Numbers

The following are the emergency telephone numbers:

- Ambulance Service911 (enhanced)
- Police911 (enhanced)
- Fire911 (enhanced)
- Northeast Regional Medical Center800-424-9300 (24 Hr.)

13.0 SITE EMERGENCY PLAN

13.1 General

The purpose of the Emergency Plan is to set forth procedures, practices and communication to be followed in the event of an emergency type of release or spill of hazardous substances and/or an emergency type of episode (fire, explosion, personnel exposure, etc.) involving hazardous materials during activities at the site. Furthermore, the program stresses the minimization of:

- hazards to human health on-site and off-site;
- the possibility of fires or explosions; and
- the possibility of a sudden and accidental release to the air or surface water.

This emergency plan provides guidance in the unlikely event of an emergency episode.

Daily communication between on-site emergency response personnel and the site Emergency Coordinator will provide awareness of episodes that may require emergency action. An initial and periodic spill prevention and control-training program will be conducted for on-site personnel. This program will make personnel aware of the following:

- the site HS Plan;
- site layout and contingency plans prior to mobilization;
- the potential emergency episodes and associated hazardous substances;
- the proper handling of hazardous substances;
- steps to be taken in case of an emergency episode;
- evacuation routes from the site; and
- the emergency route to the hospital Northeast Regional Medical Center.

It is imperative that on-site personnel remain cognizant of the emergency plan details for dealing with potential emergency episodes. Personnel will be required to signify that they have read and understood the contents of the emergency plan and its procedures and practices by signing the Health and Safety Plan Signature Record.

13.2 Emergency Coordinator

The Site Emergency Coordinator is the SSO (or designee). The Site Emergency Coordinator will be responsible for contacting the necessary emergency response groups and implementing the emergency plan. The reporting of any episodes to the appropriate authorities will also be done by the Site Emergency Coordinator. While any field activities are taking place, at least one Emergency Coordinator will be present on site.

Daily meetings discussing activities being performed during that day will be held. Discussion will include potentially dangerous situations and proper response actions.

13.3 Communication

Telephone communications will be established on site. A list of emergency telephone numbers along with a list of key site personnel will be posted in the support zone. The list of emergency telephone numbers is presented in Section 12.7 of the HS Plan. Several methods of on-site communication must be established to ensure implementation of this Emergency Plan. site communications are outlined in Section 12.1. This will allow contact to be maintained between site personnel and the site Emergency Coordinator.

13.4 Emergency Plan Execution And Implementation

The initiation and the implementation of the emergency plan described herein is the responsibility of the site Emergency Coordinator and secondary emergency coordinators.

It is the responsibility of on-site personnel noting an emergency episode (such as a spill, fire, explosion, human exposure, etc.) to immediately contact the Emergency Coordinator. Also, on-site personnel have the responsibility to bring to the immediate attention of an Emergency Coordinator any condition that has the potential for creating an emergency episode.

The Emergency Coordinator will respond immediately to any reported episode or potential episode by assessing the situation, initiating the appropriate action, and contacting the Construction Manager.

The Emergency Coordinator shall immediately notify the Construction Manager in the event of an emergency episode. The Emergency Coordinator will submit a written draft report to the Construction Manager detailing the emergency episode, and will issue, within twenty days, a formal report of the incident. Within 30 days of the conclusion of such an event, the Construction Manager will submit a report to the Solutia Project Manager setting forth actions taken in response thereto.

Assistance in responding to an emergency episode is available from the local emergency authorities. Section 12.7 lists the emergency authorities and their telephone numbers. The decision to involve an emergency authority will be made by the Emergency Coordinator.

13.5 Emergency Response Procedures For Spills, Fires And Explosions

Covered below are generalized descriptions of the actions, which should be taken for each type of episode. The circumstances and nature of a specific episode will dictate the specific steps to be taken.

13.5.1 Liquid Spill

In the unlikely event a liquid spill should occur, the liquid will first be identified and the procedures for cleanup will be specified and implemented in accordance with MSDSs for the material.

13.5.2 Solid Spill

In the unlikely event a solid spill should occur, the solid will first be identified and the procedures for cleanup will be specified and implemented in accordance with the MSDS for the material.

13.5.3 Fire

Activities at the site will be conducted in a manner that minimizes the potential for a fire. Specifically, fire prevention should be facilitated by minimizing the exposure of any ignitable materials to any type of ignition source. Severe heat (sparks, fumes or other sources of ignition) must not be present in the vicinity of hazardous wastes.

Should a fire occur, the safety of on-site personnel is foremost. Once personnel are safe, efforts will be made to identify the source of the fire. From this effort, the procedures for extinguishing the fire as specified in the MSDS for the material will be employed. However, water can be used to cool areas in the vicinity of the fire to minimize potential spread. Once the flame is extinguished, the area should be surveyed and raked for hot spots, which must be extinguished. If hazardous materials have been involved, they should be handled as spills.

13.5.4 Explosion

Should an explosion occur, personnel must be evacuated from the site until further assessment can be performed by the Emergency Coordinator.

13.6 Evacuation Plan

Upon the recognition of a potential or actual emergency condition by any site personnel, the Emergency Coordinator will be notified immediately, by whatever means appropriate (orally or by phone). The following actions will be taken:

1. After receiving notification, the Emergency Coordinator will perform an initial assessment of the situation, and determine the need for on-site actions, evacuation, and/or notification of off-site emergency responders.
2. If a site evacuation is deemed necessary, the Emergency Coordinator will initiate the evacuation by sounding an audible alarm using an air horn. Site workers will immediately leave the area and proceed to the predetermined upwind assembly location. Each contractor's supervisor will conduct a head count at the pre-determined assembly location.
3. The Emergency Coordinator will be advised of the head count results, and will direct attempts to determine the location of the missing personnel. No re-entry of the site will be made until the emergency condition has been controlled. If personnel cannot be accounted for, the Emergency Coordinator will advise the Construction Manager and SSO of the missing personnel.
4. The Emergency Coordinator will be responsible for initiating contact with the appropriate emergency response agencies, maintaining control of the affected area so as to restrict entry to emergency response personnel only, and gathering information concerning the event in order to inform emergency response personnel as to the events leading up to the episode.
5. The Emergency Coordinator will arrange for off-site assistance, under the direction of emergency response personnel, in order to remedy the emergency situation.
6. The Emergency Coordinator will not initiate re-entry until:
 - The conditions resulting in the emergency have been corrected;
 - The hazards have been reassessed;
 - The site HS Plan has been reviewed; and
 - Site personnel have been briefed on any changes in the HS Plan.

14.0 REPORTING REQUIREMENTS

14.1 Health And Safety Logbook

The SSO will keep a logbook to record information, the names of personnel working on-site, and the names of visitors to the site. At a minimum, the following information should be recorded in the logbook on a daily basis:

- weather;
- personnel on-site, company and title;
- proposed work activity;
- level(s) of protection worn;
- air monitoring equipment readings obtained during work activities;
- any health and safety-related issues or situations; and
- daily start-up findings.

15.0 REFERENCES

Agency for Toxic Substances and Disease Registry (ATSDR). Toxicological profile for (certain chemicals).

American Conference of Government Industrial Hygienists (ACGIH), "Threshold Limit Values for Chemical Substances and Physical Agents and Biological Exposure Indices", 2000 and TLV Documentation Guide.

Code of Federal Regulations, Title 29, Part 1910, Subsections 120 and 126.

National Institute of Occupational Health and Safety (NIOSH), "Pocket Guide to Chemical Hazards", Latest Edition.

NIOSH/OSHA/USCG/EPA "Occupational Safety and Health Guidance Manual for Hazardous Waste site Activities", 1985.

NIOSH, "NIOSH Respirator Decision Logic", May 1987.

TABLE 1
ACTION LEVELS OF CHEMICALS EXPECTED

Compound	OSHA PEL	ACGIH TLV	STEL
Chlorinated biphenyls (42% chlorine)*	1 mg/m ³ (skin)	1 mg/m ³ (skin)	--
Chlorinated biphenyls (54% chlorine)*	0.5 mg/m ³ (skin)	0.5 mg/m ³ (skin)	--
Antimony	0.5 mg/m ³	0.5 mg/m ³	--
Arsenic* (inorganic)	0.01 mg/m ³	0.01 mg/m ³	--
Beryllium*	0.005 mg/m ³	0.002 mg/m ³	--
Cadmium*	0.05 mg/m ³	0.01 mg/m ³ (inh) 0.002 mg/m ³ (res)	--
Chromium	0.5 mg/m ³	0.5 mg/m ³	--
Copper	1 mg/m ³ (dust)	1 mg/m ³ (dust)	--
Lead	0.05 mg/m ³	0.05 mg/m ³	--
Mercury (inorganic)	0.1 mg/m ³	0.025 mg/m ³	--
Nickel* (elemental)	1 mg/m ³	1.5 mg/m ³	--
Selenium	0.2 mg/m ³	0.2 mg/m ³	--
Silver	0.01 mg/m ³	0.01 mg/m ³	--
Thallium	0.1 mg/m ³	0.1 mg/m ³	--
Zinc	15 mg/m ³	10 mg/m ³	--

*Suspected Human Carcinogen
ACGIH TLV - American Conference of Governmental Industrial Hygienists' Threshold Limit Values for Chemical Substances and Physical Agents and Biological Exposure Indices 2000

PEL - Permissible Exposure Limit (8-hr TWA)

STEL - Short Term Exposure Limit

Inh - Inhalable particulate matter

Res - Respirable particulate matter

(C) Ceiling value not to be exceeded anytime during work shift

Note:

-- - No value established.

TABLE 2
HEAT STRESS: BASIS FOR WORK SCHEDULE

DURATION OF WORK		
AMBIENT TEMPERATURE (°F)	NORMAL WORK CLOTHING ¹	IMPERMEABLE WORK CLOTHING
70° – 80°	N/A	90 MIN
80° -85°	120 MIN	60 MIN
85° -90°	90 MIN	30 MIN
> 90°	60 MIN	15 MIN

¹Normal work clothing is cotton coveralls, or other cotton clothing with long sleeves and pants.

**TABLE 3
ACTION LEVELS FOR PERSONAL PROTECTION
AND/OR WORK STOPPAGE**

DUST MONITORING FOR PARTICULATES	
Background Levels	Level D
< 5.0 mg/m ³ in breathing zone	Continue work in Level D
> 5.0 mg/m ³ in breathing zone	Implement dust controls. Upgrade PPE to Level C and continue work.
> 50.0 mg/m ³ in breathing zone	Implement dust controls. Stop work.
NOISE MONITORING	
<85 dBA	Normal operations, continue monitoring
>85 dBA	Hearing protection required.

TABLE 4

ACTIVITIES PPE REQUIREMENTS

Task	Respiratory	Clothing	Gloves	Boots	Other *
Soil Removal	NA**	T	W	B	HH/SG/HP
Soil Placement	NA**	T	W	B	HH/SG/HP
Geosynthetic Placement	NA**	C	W	B	HH/SG/HP
Underground Utility Removal and Installation	NA**	T/C*	W*	F/B*	HH/SG/HP
Aboveground Utility Removal and Installation	NA	T/C*	W*	F/B*	HH/SG/HP
Final Grading/Sealing	NA**	C	W	B	HH/SG/HP

NOTES:

- B = Steel-toe work boots
- C = Cotton overalls
- F = Steel-toe fireman's boots
- HH = Hard hat
- HP = Hearing Protection
- N = Nitrile
- NA = Not Anticipated
- S = Surgical
- SG = Safety glasses
- T = Tyvek
- W = Work Gloves
- * = Depending on Area
- ** = SSO may require upgrade to NIOSH approved respirators with HEPA cartridges

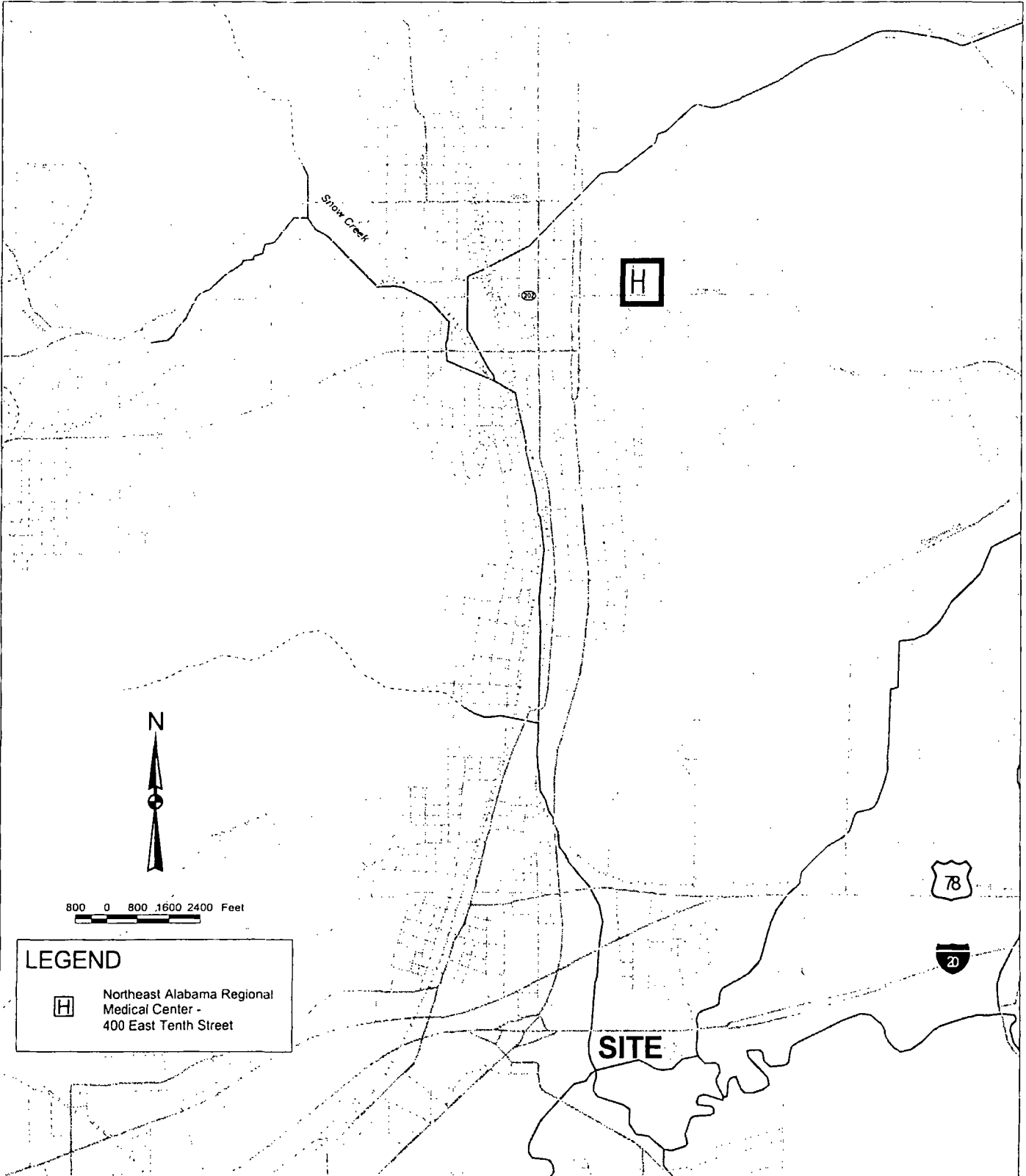

LEGEND

 Northeast Alabama Regional Medical Center - 400 East Tenth Street

 <p>Golder Associates Atlanta, Georgia</p>	<p>TITLE</p> <p style="text-align: center;">Site and Hospital Location</p>			
	<p>CLIENT/PROJECT</p> <p style="text-align: center;">Health and Safety Plan</p>	<p>CREATED JES</p> <p>CHECKED <i>SM</i></p> <p>REVIEWED</p>	<p>DATE 01-16-03</p> <p>SCALE 1:42,000</p> <p>FILE Q:\..0058.apr</p>	<p>JOB NO 943-3680</p> <p>PRINT FILE Hos wwtp.eps</p> <p>LAYOUT lytHos-wwtp</p>

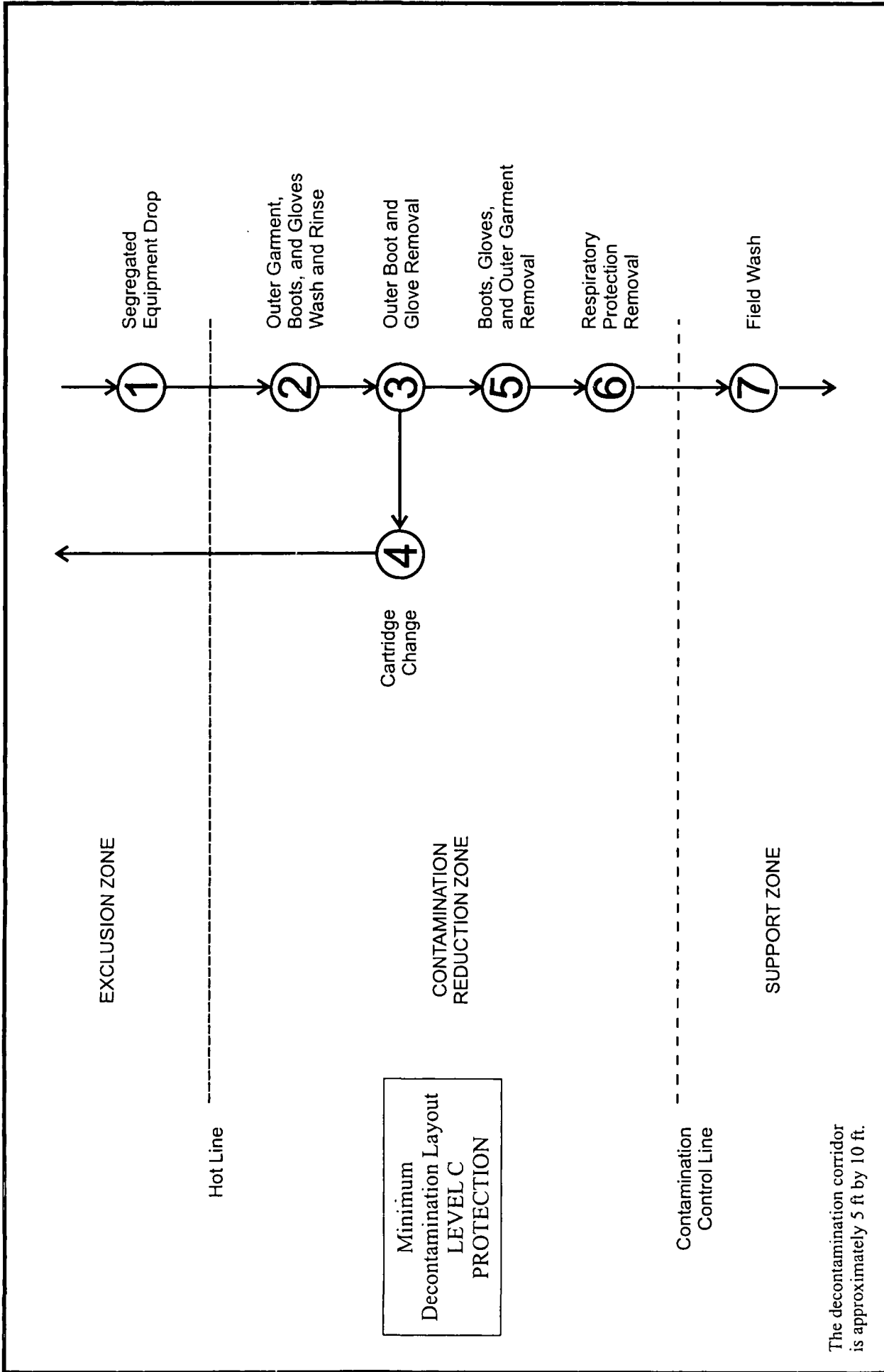

CLIENT/PROJECT		Health and Safety Plan		 Golder Associates Atlanta, Georgia		TITLE		Outline for Level C Decontamination	
DRAWN	CHECKED	REVIEWED	DATE	SCALE	FILE NO.	JOB NO.	DWG NO./REV. NO.	HASP.cdr	FIGURE
SDP	5.7		16-Jan-2003	N/A	N/A	943-3680.WTP			2

EXCLUSION ZONE

Hot Line

Segregated
Equipment Drop

Outer Garment,
Boots, and Gloves
Wash and Rinse

CONTAMINATION
REDUCTION ZONE

Boots, Gloves,
and Outer Garment
Removal

SUPPORT ZONE

Field Wash

Minimum
Decontamination Layout
LEVEL D
PROTECTION

The decontamination corridor
is approximately 5 ft by 10 ft.

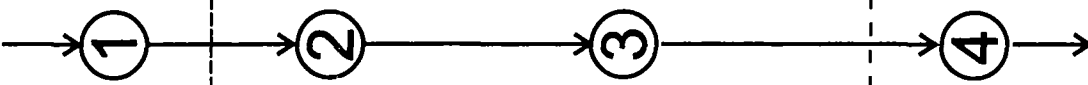

CLIENT/PROJECT

Health and Safety Plan



Atlanta, Georgia

TITLE

Outline for Level D Decontamination

DRAWN

CHECKED

SDP

REVIEWED

5'-4"

DATE

16-Jan-2003

SCALE

N/A

FILE NO.

Atlanta, Georgia

JOB NO.

943-3680.WTP

FIGURE

HASP.cdr

3

APPENDIX A

HEALTH AND SAFETY PLAN ADDENDUM/REVISION

Date: _____

site Designation/Location: _____

Subject: _____

Addendum: _____

Affected Health and Safety Plan Section: _____

Revision: _____

Requested by: Signature: _____

Printed Name: _____

Title: _____

Effective Date: _____

Approved By: Signature: _____

Printed Name: _____

Title: _____

CONCURRENCE (by Project Manager and Health and Safety Officer or Health and Safety Coordinator):

Effective Date: _____

Approved By: Signature: _____

Printed Name: _____

Title: _____

NOTES/REMARKS:

APPENDIX B

MSDS for ANTIMONY

Page 1

1 - PRODUCT IDENTIFICATION

PRODUCT NAME: ANTIMONY
 FORMULA: SB
 FORMULA WT: 121.75
 CAS NO.: 07440-36-0
 NIOSH/RTECS NO.: CC4025000
 COMMON SYNONYMS: STIBIUM, C.I. 77050
 PRODUCT CODES: 0848
 EFFECTIVE: 08/27/86
 REVISION #03

PRECAUTIONARY LABELLING

BAKER SAF-T-DATA(TM) SYSTEM

HEALTH - 3 SEVERE (POISON)
 FLAMMABILITY - 1 SLIGHT
 REACTIVITY - 2 MODERATE
 CONTACT - 1 SLIGHT

HAZARD RATINGS ARE 0 TO 4 (0 = NO HAZARD; 4 = EXTREME HAZARD).

LABORATORY PROTECTIVE EQUIPMENT

GOGGLES; LAB COAT; VENT HOOD; PROPER GLOVES

PRECAUTIONARY LABEL STATEMENTS

POISON DANGER
 MAY BE FATAL IF INHALED
 CAUSES IRRITATION

AVOID CONTACT WITH EYES, SKIN, CLOTHING.
 DO NOT BREATHE DUST. KEEP IN TIGHTLY CLOSED CONTAINER. USE WITH ADEQUATE
 VENTILATION. WASH THOROUGHLY AFTER HANDLING.

SAF-T-DATA(TM) STORAGE COLOR CODE: BLUE (HEALTH)

2 - HAZARDOUS COMPONENTS

COMPONENT	%	CAS NO.
ANTIMONY	90-100	7440-36-0

3 - PHYSICAL DATA

BOILING POINT: 1635 C (2975 F) VAPOR PRESSURE(MM HG): N/A
 MELTING POINT: 630 C (1166 F) VAPOR DENSITY(AIR=1): 4.2
 SPECIFIC GRAVITY: 6.68 EVAPORATION RATE: N/A
 □

MSDS for ANTIMONY

Page 2

(H2O=1)

(BUTYL ACETATE=1)

SOLUBILITY(H2O): NEGLIGIBLE (LESS THAN 0.1 %) % VOLATILES BY VOLUME: 0

APPEARANCE & ODOR: SILVER-WHITE, HARD, BRITTLE METAL.

4 - FIRE AND EXPLOSION HAZARD DATA

FLASH POINT (CLOSED CUP: N/A

FLAMMABLE LIMITS: UPPER - N/A % LOWER - N/A %

FIRE EXTINGUISHING MEDIA

USE EXTINGUISHING MEDIA APPROPRIATE FOR SURROUNDING FIRE.

UNUSUAL FIRE & EXPLOSION HAZARDS

CAN BE AN EXPLOSION HAZARD, ESPECIALLY WHEN HEATED.

5 - HEALTH HAZARD DATA

THRESHOLD LIMIT VALUE (TLV/TWA): 0.5 MG/M3 (PPM)

PERMISSIBLE EXPOSURE LIMIT (PEL): 0.5 MG/M3 (PPM)

CARCINOGENICITY: NTP: NO IARC: NO Z LIST: NO OSHA REG: NO

EFFECTS OF OVEREXPOSURE

INHALATION MAY BE HARMFUL OR FATAL.

PROLONGED EXPOSURE MAY CAUSE DERMATITIS.

CHRONIC EFFECTS OF OVEREXPOSURE MAY INCLUDE KIDNEY AND/OR LIVER DAMAGE.

NOTE: PRODUCT IS A SOLID MASS; HOWEVER, WARNINGS ARE BASED ON INHALATION DUST, MIST OR FUME EMISSIONS THAT ARE POSSIBLE DURING MANUFACTURING OR CHEMICAL REACTIONS.

TARGET ORGANS

RESPIRATORY SYSTEM, CARDIOVASCULAR SYSTEM, EYES, SKIN

MEDICAL CONDITIONS GENERALLY AGGRAVATED BY EXPOSURE

NONE IDENTIFIED

ROUTES OF ENTRY

INHALATION, EYE CONTACT, SKIN CONTACT

EMERGENCY AND FIRST AID PROCEDURES

IF INHALED, REMOVE TO FRESH AIR. IF NOT BREATHING, GIVE ARTIFICIAL RESPIRATION. IF BREATHING IS DIFFICULT, GIVE OXYGEN.

IN CASE OF CONTACT, IMMEDIATELY FLUSH EYES WITH PLENTY OF WATER FOR AT LEAST 15 MINUTES. FLUSH SKIN WITH WATER.

6 - REACTIVITY DATA
----- MSDS for ANTIMONY

Page 3

STABILITY: STABLE

HAZARDOUS POLYMERIZATION: WILL NOT OCCUR

CONDITIONS TO AVOID: HEAT, LIGHT

INCOMPATIBLES: STRONG OXIDIZING AGENTS, STRONG ACIDS, HALOGEN ACIDS,
CHLORINE, FLUORINE

7 - SPILL AND DISPOSAL PROCEDURES

STEPS TO BE TAKEN IN THE EVENT OF A SPILL OR DISCHARGE

WEAR SELF-CONTAINED BREATHING APPARATUS AND FULL PROTECTIVE CLOTHING.
WITH CLEAN SHOVEL, CAREFULLY PLACE MATERIAL INTO CLEAN, DRY CONTAINER AND
COVER; REMOVE FROM AREA. FLUSH SPILL AREA WITH WATER.

DISPOSAL PROCEDURE

DISPOSE IN ACCORDANCE WITH ALL APPLICABLE FEDERAL, STATE, AND LOCAL
ENVIRONMENTAL REGULATIONS.

8 - PROTECTIVE EQUIPMENT

VENTILATION: USE GENERAL OR LOCAL EXHAUST VENTILATION TO MEET
TLV REQUIREMENTS.

RESPIRATORY PROTECTION: RESPIRATORY PROTECTION REQUIRED IF AIRBORNE
CONCENTRATION EXCEEDS TLV. AT CONCENTRATIONS UP
TO 1 PPM, A DUST/MIST RESPIRATOR IS
RECOMMENDED. ABOVE THIS LEVEL, A SELF-CONTAINED
BREATHING APPARATUS IS ADVISED.

EYE/SKIN PROTECTION: SAFETY GOGGLES, UNIFORM, APRON, PROPER GLOVES ARE
RECOMMENDED.

9 - STORAGE AND HANDLING PRECAUTIONS

SAF-T-DATA (TM) STORAGE COLOR CODE: BLUE (HEALTH)

SPECIAL PRECAUTIONS

KEEP CONTAINER TIGHTLY CLOSED. STORE IN SECURE POISON AREA.
KEEP PRODUCT OUT OF LIGHT.

10 - TRANSPORTATION DATA AND ADDITIONAL INFORMATION

DOMESTIC (D.O.T.)

PROPER SHIPPING NAME	ANTIMONY, POWDER
HAZARD CLASS	ORM-E
LABELS	NONE
REPORTABLE QUANTITY	5000 LBS.

MSDS for ANTIMONY

Page 4

INTERNATIONAL (I.M.O.)

PROPER SHIPPING NAME	ANTIMONY, POWDER
HAZARD CLASS	6.1
UN/NA	UN2871

LABELS

HARMFUL - STOW AWAY FROM FOOD STUFFS

□

 MSDS for ARSENIC, 1000 PPM (0.100% W/V)

Page 1

 1 - PRODUCT IDENTIFICATION

PRODUCT NAME: ARSENIC, 1000 PPM (0.100% W/V)
 FORMULA: AS2O3 IN HCL
 FORMULA WT: 74.90
 CAS NO.: - - -
 PRODUCT CODES: 6919
 EFFECTIVE: 08/15/86
 REVISION #02

PRECAUTIONARY LABELLING

BAKER SAF-T-DATA(TM) SYSTEM

HEALTH - 4 EXTREME (CANCER CAUSING)
 FLAMMABILITY - 0 NONE
 REACTIVITY - 2 MODERATE
 CONTACT - 2 MODERATE

HAZARD RATINGS ARE 0 TO 4 (0 = NO HAZARD; 4 = EXTREME HAZARD).

LABORATORY PROTECTIVE EQUIPMENT

GOGGLES & SHIELD; LAB COAT & APRON; VENT HOOD; PROPER GLOVES

PRECAUTIONARY LABEL STATEMENTS

POISON DANGER
 CAUSES IRRITATION
 MAY BE FATAL IF SWALLOWED

CAUTION: CONTAINS INORGANIC ARSENIC, CANCER HAZARD

DO NOT GET IN EYES, ON SKIN, ON CLOTHING.

DO NOT BREATHE VAPOR. KEEP IN TIGHTLY CLOSED CONTAINER. USE WITH ADEQUATE VENTILATION. WASH THOROUGHLY AFTER HANDLING.

SAF-T-DATA(TM) STORAGE COLOR CODE: BLUE (HEALTH)

 2 - HAZARDOUS COMPONENTS

COMPONENT	%	CAS NO.
ARSENIC TRIOXIDE	0-1	1327-53-3
HYDROCHLORIC ACID (0.3 MOLAR)	0-1	7647-01-0

 3 - PHYSICAL DATA

BOILING POINT: 100 C (212 F) VAPOR PRESSURE(MM HG): N/A
 MELTING POINT: 0 C (32 F) VAPOR DENSITY(AIR=1): N/A
 SPECIFIC GRAVITY: N/A EVAPORATION RATE: N/A

 MSDS for ARSENIC, 1000 PPM (0.100% W/V)

Page 2

(H2O=1)

(BUTYL ACETATE=1)

SOLUBILITY(H2O): COMPLETE (IN ALL PROPORTIONS) % VOLATILES BY VOLUME: ~100
 APPEARANCE & ODOR: CLEAR COLORLESS SOLUTION WITH NO ODOR.

 4 - FIRE AND EXPLOSION HAZARD DATA

FLASH POINT (CLOSED CUP: N/A NFPA 704M RATING: 3-0-0

FLAMMABLE LIMITS: UPPER - N/A % LOWER - N/A %

FIRE EXTINGUISHING MEDIA

USE EXTINGUISHING MEDIA APPROPRIATE FOR SURROUNDING FIRE.

SPECIAL FIRE-FIGHTING PROCEDURES

FIREFIGHTERS SHOULD WEAR PROPER PROTECTIVE EQUIPMENT AND SELF-CONTAINED BREATHING APPARATUS WITH FULL FACEPIECE OPERATED IN POSITIVE PRESSURE MODE.

TOXIC GASES PRODUCED

HYDROGEN CHLORIDE

 5 - HEALTH HAZARD DATA

THIS SUBSTANCE IS LISTED AS ACGIH SUSPECT HUMAN CARCINOGEN, NTP HUMAN CARCINOGEN, AND IARC HUMAN CARCINOGEN (GROUP 1).

THRESHOLD LIMIT VALUE (TLV/TWA): 0.2 MG/M3 (PPM)

PERMISSIBLE EXPOSURE LIMIT (PEL): 0.5 MG/M3 (PPM)

TOXICITY: LD50 (ORAL-RAT) (MG/KG) - 20

CARCINOGENICITY: NTP: YES IARC: YES Z LIST: YES OSHA REG: YES

EFFECTS OF OVEREXPOSURE

INGESTION IS HARMFUL AND MAY BE FATAL.
 VAPORS MAY BE IRRITATING TO SKIN, EYES, AND MUCOUS MEMBRANES.
 INHALATION OF VAPORS MAY CAUSE SEVERE IRRITATION OF THE RESPIRATORY SYSTEM.
 CONTACT WITH SKIN OR EYES MAY CAUSE SEVERE IRRITATION OR BURNS.
 INGESTION MAY CAUSE NAUSEA, VOMITING, PARALYSIS.
 INGESTION MAY CAUSE GASTROINTESTINAL IRRITATION.

TARGET ORGANS

LIVER, KIDNEYS, SKIN, LUNGS, LYMPHATIC SYSTEM

MEDICAL CONDITIONS GENERALLY AGGRAVATED BY EXPOSURE

NONE IDENTIFIED

ROUTES OF ENTRY

INHALATION, INGESTION, ABSORPTION, EYE CONTACT, SKIN CONTACT

 MSDS for ARSENIC, 1000 PPM (0.100% W/V)

Page 3

EMERGENCY AND FIRST AID PROCEDURES

CALL A PHYSICIAN.

DOMESTIC (D.O.T.)

PROPER SHIPPING NAME	HYDROCHLORIC ACID, SOLUTION
HAZARD CLASS	CORROSIVE MATERIAL (LIQUID)
UN/NA	UN1789
LABELS	CORROSIVE
REPORTABLE QUANTITY	5000 LBS.

INTERNATIONAL (I.M.O.)

PROPER SHIPPING NAME	HYDROCHLORIC ACID, SOLUTION, MIXTURE
HAZARD CLASS	8
UN/NA	UN1789
LABELS	CORROSIVE

□

 MSDS for BERYLLIUM, 1000 PPM (0.100% W/V) Page 1

 I - PRODUCT IDENTIFICATION

PRODUCT NAME: BERYLLIUM, 1000 PPM (0.100% W/V)
 FORMULA: BE IN HCL
 FORMULA WT: 9.00
 CAS NO.: - -
 PRODUCT CODES: 6921
 EFFECTIVE: 09/05/86
 REVISION #02

PRECAUTIONARY LABELLING

BAKER SAF-T-DATA(TM) SYSTEM

HEALTH - 3 SEVERE (CANCER CAUSING)
 FLAMMABILITY - 0 NONE
 REACTIVITY - 2 MODERATE
 CONTACT - 3 SEVERE (CORROSIVE)

HAZARD RATINGS ARE 0 TO 4 (0 = NO HAZARD; 4 = EXTREME HAZARD).

LABORATORY PROTECTIVE EQUIPMENT

GOGGLES & SHIELD; LAB COAT & APRON; VENT HOOD; PROPER GLOVES

PRECAUTIONARY LABEL STATEMENTS

POISON DANGER
 CAUSES BURNS

NOTE: REPORTED AS CAUSING CANCER IN LABORATORY ANIMALS. EXERCISE DUE CARE.
 DO NOT GET IN EYES, ON SKIN, ON CLOTHING.
 DO NOT BREATHE VAPOR. KEEP IN TIGHTLY CLOSED CONTAINER. USE WITH ADEQUATE
 VENTILATION. WASH THOROUGHLY AFTER HANDLING.

SAF-T-DATA(TM) STORAGE COLOR CODE: WHITE (CORROSIVE)

 2 - HAZARDOUS COMPONENTS

COMPONENT	%	CAS NO.
BERYLLIUM	0-1	7440-41-7
HYDROCHLORIC ACID (0.3 MOLAR)	0-1	7647-01-0

 3 - PHYSICAL DATA

BOILING POINT: 100 C (212 F) VAPOR PRESSURE(MM HG): N/A
 MELTING POINT: N/A VAPOR DENSITY(AIR=1): N/A
 SPECIFIC GRAVITY: 1.00 EVAPORATION RATE: N/A
 (H2O=1) (BUTYL ACETATE=1)

 MSDS for BERYLLIUM, 1000 PPM (0.100% W/V) Page 2

SOLUBILITY(H₂O): COMPLETE (IN ALL PROPORTIONS) % VOLATILES BY VOLUME: N/A

APPEARANCE & ODOR: CLEAR COLORLESS SOLUTION.

4 - FIRE AND EXPLOSION HAZARD DATA

FLASH POINT (CLOSED CUP: N/A NFPA 704M RATING: 3-0-0

FLAMMABLE LIMITS: UPPER - N/A % LOWER - N/A %

FIRE EXTINGUISHING MEDIA

USE EXTINGUISHING MEDIA APPROPRIATE FOR SURROUNDING FIRE.

5 - HEALTH HAZARD DATA

THIS SUBSTANCE IS LISTED AS ACGIH SUSPECT HUMAN CARCINOGEN, NTP ANTICIPATED HUMAN CARCINOGEN, IARC PROBABLE HUMAN CARCINOGEN (GROUPS 2A AND 2B); ACCEPTABLE MAXIMUM PEAK ABOVE THE ACCEPTANCE CEILING CONCENTRATION FOR AN EIGHT-HOUR SHIFT = .025 MG/M³ FOR 30 MINUTES; (PEL) CEILING = .005 MG/M³.

THRESHOLD LIMIT VALUE (TLV/TWA): .002 MG/M³ (PPM)

PERMISSIBLE EXPOSURE LIMIT (PEL): .002 MG/M³ (PPM)

TOXICITY: LD50 (IV-RAT) (MG/KG) - .496

CARCINOGENICITY: NTP: YES IARC: YES Z LIST: NO OSHA REG: NO

EFFECTS OF OVEREXPOSURE

LIQUID MAY CAUSE BURNS TO SKIN AND EYES.

VAPORS MAY BE IRRITATING TO SKIN, EYES, NOSE AND THROAT.

INHALATION OF VAPORS MAY CAUSE COUGHING AND DIFFICULT BREATHING.

TARGET ORGANS

LUNGS, SKIN, EYES, MUCOUS MEMBRANES

MEDICAL CONDITIONS GENERALLY AGGRAVATED BY EXPOSURE

NONE IDENTIFIED

ROUTES OF ENTRY

INHALATION

EMERGENCY AND FIRST AID PROCEDURES

CALL A PHYSICIAN.

IF SWALLOWED, IF CONSCIOUS, IMMEDIATELY INDUCE VOMITING.

IF INHALED, REMOVE TO FRESH AIR. IF NOT BREATHING, GIVE ARTIFICIAL RESPIRATION. IF BREATHING IS DIFFICULT, GIVE OXYGEN.

IN CASE OF CONTACT, IMMEDIATELY FLUSH EYES OR SKIN WITH PLENTY OF WATER FOR AT LEAST 15 MINUTES WHILE REMOVING CONTAMINATED CLOTHING AND SHOES.

WASH CLOTHING BEFORE RE-USE.

□

MSDS for BERYLLIUM, 1000 PPM (0.100% W/V)

Page 3

TOXICITY TEST RESULTS AND SAFETY AND HEALTH EFFECTS ARE BASED ON THE SOLUTE.

PROPER SHIPPING NAME	HYDROCHLORIC ACID, SOLUTION, MIXTURE
HAZARD CLASS	8
UN/NA	UN1789
LABELS	CORROSIVE

□

MSDS for CADMIUM, 1000 PPM (0.100% W/V)Page 1

1 - PRODUCT IDENTIFICATION

PRODUCT NAME: CADMIUM, 1000 PPM (0.100% W/V)
 FORMULA: CD IN HNO3
 FORMULA WT: 112.40
 CAS NO.: - - -
 PRODUCT CODES: 6924
 EFFECTIVE: 09/10/86
 REVISION #02

PRECAUTIONARY LABELLING

BAKER SAF-T-DATA(TM) SYSTEM

HEALTH - 3 SEVERE (CANCER CAUSING)
 FLAMMABILITY - 0 NONE
 REACTIVITY - 1 SLIGHT
 CONTACT - 3 SEVERE (CORROSIVE)

HAZARD RATINGS ARE 0 TO 4 (0 = NO HAZARD; 4 = EXTREME HAZARD).

LABORATORY PROTECTIVE EQUIPMENT

GOGGLES & SHIELD; LAB COAT & APRON; VENT HOOD; PROPER GLOVES

PRECAUTIONARY LABEL STATEMENTS

DANGER

CAUSES BURNS

HARMFUL IF SWALLOWED OR INHALED

NOTE: REPORTED AS CAUSING CANCER IN LABORATORY ANIMALS. EXERCISE DUE CARE.
 DO NOT GET IN EYES, ON SKIN, ON CLOTHING.
 DO NOT BREATHE VAPOR. KEEP IN TIGHTLY CLOSED CONTAINER. USE WITH ADEQUATE
 VENTILATION. WASH THOROUGHLY AFTER HANDLING.

SAF-T-DATA(TM) STORAGE COLOR CODE: WHITE (CORROSIVE)

2 - HAZARDOUS COMPONENTS

COMPONENT	%	CAS NO.
CADMIUM	0-1	7440-43-9
NITRIC ACID (0.3 MOLAR)	1-2	7697-37-2

3 - PHYSICAL DATA

BOILING POINT: N/A VAPOR PRESSURE(MM HG): N/A
 MELTING POINT: N/A VAPOR DENSITY(AIR=1): N/A
 SPECIFIC GRAVITY: 1.00 EVAPORATION RATE: N/A
 □

MSDS for CADMIUM, 1000 PPM (0.100% W/V)Page 2

(H2O=1)

(BUTYL ACETATE=1)

SOLUBILITY(H2O): COMPLETE (IN ALL PROPORTIONS) % VOLATILES BY VOLUME: ~100
 APPEARANCE & ODOR: CLEAR, COLORLESS ODORLESS SOLUTION.

 4 - FIRE AND EXPLOSION HAZARD DATA

FLASH POINT (CLOSED CUP: N/A NFPA 704M RATING: 3-0-0 OXY

FLAMMABLE LIMITS: UPPER - N/A % LOWER - N/A %

FIRE EXTINGUISHING MEDIA

USE EXTINGUISHING MEDIA APPROPRIATE FOR SURROUNDING FIRE.

SPECIAL FIRE-FIGHTING PROCEDURES

FIREFIGHTERS SHOULD WEAR PROPER PROTECTIVE EQUIPMENT AND SELF-CONTAINED BREATHING APPARATUS WITH FULL FACEPIECE OPERATED IN POSITIVE PRESSURE MODE.

TOXIC GASES PRODUCED

NITROGEN OXIDES

 5 - HEALTH HAZARD DATA

THIS SUBSTANCE IS LISTED AS NTP ANTICIPATED HUMAN CARCINOGEN, IARC PROBABLE HUMAN CARCINOGEN (GROUPS 2A AND 2B). THE ACCEPTABLE CEILING CONCENTRATION (PEL) IS 0.6 MG/M3.

THRESHOLD LIMIT VALUE (TLV/TWA): 0.05 MG/M3 (PPM)

PERMISSIBLE EXPOSURE LIMIT (PEL): 0.2 MG/M3 (PPM)

TOXICITY: LD50 (ORAL-RAT) (MG/KG) - 225

CARCINOGENICITY: NTP: YES IARC: YES Z LIST: NO OSHA REG: NO

EFFECTS OF OVEREXPOSURE

INHALATION OF VAPORS MAY CAUSE NAUSEA, VOMITING, LIGHTEADEDNESS OR HEADACHE.

LIQUID MAY CAUSE BURNS TO SKIN AND EYES.

INGESTION MAY CAUSE NAUSEA, VOMITING, GASTROINTESTINAL IRRITATION, AND BURNS TO MOUTH AND THROAT.

CHRONIC EFFECTS OF CADMIUM COMPOUNDS FROM LOW LEVEL EXPOSURE IN THE AIR MAY CAUSE IRREVERSIBLE LUNG INJURY, KIDNEY DISEASE, AND OTHER ADVERSE EFFECTS.

TARGET ORGANS

RESPIRATORY SYSTEM, KIDNEYS, PROSTATE, BLOOD

MEDICAL CONDITIONS GENERALLY AGGRAVATED BY EXPOSURE

NONE IDENTIFIED

 MSDS for CADMIUM, 1000 PPM (0.100% W/V)

Page 3

ROUTES OF ENTRY

INHALATION, INGESTION

SAF-T-DATA(TM) STORAGE COLOR CODE: WHITE (CORROSIVE)

SPECIAL PRECAUTIONS

KEEP CONTAINER TIGHTLY CLOSED. STORE IN CORROSION-PROOF AREA.

10 - TRANSPORTATION DATA AND ADDITIONAL INFORMATION

DOMESTIC (D.O.T.)

PROPER SHIPPING NAME	NITRIC ACID, 40% OR LESS SOLUTION
HAZARD CLASS	CORROSIVE MATERIAL (LIQUID)
UN/NA	NA1760
LABELS	CORROSIVE
REPORTABLE QUANTITY	1000 LBS.

INTERNATIONAL (I.M.O.)

PROPER SHIPPING NAME	NITRIC ACID, SOLUTION
HAZARD CLASS	8
UN/NA	UN2031
LABELS	CORROSIVE

□

Safety data for chromium

General

Synonyms:
Molecular formula: Cr
CAS No: 7440-47-3
EC No:

Physical data

Appearance: silver metal
Melting point: 1900 C
Boiling point: 2200 C
Vapour density:
Vapour pressure:
Specific gravity: 7.14
Flash point:
Explosion limits:
Autoignition temperature:

Stability

Stable. Incompatible with carbonates, strong bases, mineral acids.

Toxicology

Typical TLV (dust) 0.5 mg/m³.

Transport information

UN Major hazard class
Packing group

Personal protection

Avoid exposure to dust.

This information was last updated on June 23, 1999. We have tried to make it as accurate and useful as possible but can take no responsibility for its use, misuse, or accuracy. We have not verified this information, and cannot guarantee that it is up-to-date.

Safety data for copper

General

Synonyms: bronze powder, arnwood copper
Molecular formula: Cu
CAS No: 7440-50-8
EC No:

Physical data

Appearance: reddish lustrous malleable metal
Melting point: 1083 C
Boiling point: 2595 C
Specific gravity: 8.92
Vapour pressure:
Flash point:
Explosion limits:
Autoignition temperature:

Stability

Stable. Incompatible with strong acids, active halogen compounds, chlorine, fluorine, iodine, bromine, ammonia.

Toxicology

Dust may cause respiratory irritation.

Personal protection

Suitable ventilation if handling powder.

This information was last updated on September 18, 2000. Although we have tried to make it as accurate and useful as possible, we can take no responsibility for its use or misuse.

Safety data for lead

General

Synonyms: lead shot, C.I. 77575. [Note: the exact formulation of lead obtained as lead shot may vary; it may contain small amounts of antimony, arsenic and other materials.]

Molecular formula: Pb

CAS No: 7439-92-1

EINECS No:

Physical data

Appearance: grey metal granules, shot or powder

Melting point: 327 C

Boiling point: 1744 C

Vapour density:

Vapour pressure:

Density (g cm⁻³): 11.34

Flash point:

Explosion limits:

Autoignition temperature:

Water solubility:

Stability

Stable. Incompatible with strong oxidizing agents, potassium, sodium.

Toxicology

Toxic by ingestion or inhalation. Chronic poison. Typical TLV/TWA as powder 0.15 mg/m³.
Typical PEL 0.05 mg/m³

Transport information

Non-hazardous for air, sea and road transport.

Personal protection

Solid lead is believed to present a relatively low hazard to health, but it is a cumulative poison, and can cause serious harm if inhaled as a powder, or ingested over a long period. Most lead salts are very poisonous.

[\[Return to Physical & Theoretical Chemistry Lab. Safety home page.\]](#)

This information was last updated on July 25, 2000. We have tried to make it as accurate and useful as possible, but can take no responsibility for its use, misuse, or accuracy. We have not verified this information, and cannot guarantee that it is up-to-date.

Safety data for mercury

General

Synonyms: quicksilver
Molecular formula: Hg
CAS No: 7439-97-6
EINECS No: 231-106-7

Physical data

Appearance: silvery liquid metal
Melting point: -39 C
Boiling point: 357 C
Vapour density:
Vapour pressure: 0.002 mm Hg at 20 C
Density (g cm⁻³): 13.53
Flash point:
Explosion limits:
Autoignition temperature:
Water solubility:

Stability

Stable. Incompatible with strong acids.

Toxicology

Highly toxic. Long-term exposure to the metal may be fatal. Inhalation may lead to liver, kidney and CNS damage. Danger of cumulative effects. Harmful by ingestion and by skin contact. Typical TLV/TWA 0.05 mg/m³. Typical PEL 0.1 mg/m³.

Toxicity data

IHL-RBT LCLO 29 mg m⁻³

IHL-RBT ACUTE 28 mg m⁻³

IHL-RAT CHRONIC 0.3 mg m⁻³

IHL-RBT CHRONIC 0.1 - 6 mg m⁻³

IHL-MAN TCLO 150 microg/m³/46d: CNS, GIT

Risk phrases

R23 R33.

Transport information

CGD UK Major hazard class
Packing group

Personal protection

Good ventilation. Do not use in the open laboratory.

Safety phrases
R7 R44.

[Return to [Physical & Theoretical Chemistry Lab. Safety home page.](#)]

This information was last updated on February 19, 2000. We have tried to make it as accurate and useful as possible, but can take no responsibility for its use, misuse, or accuracy. We have not verified this information, and cannot guarantee that it is up-to-date.

MSDS for NICKEL, 1000 PPM (0.100% W/V)

Page 1

1 - PRODUCT IDENTIFICATION

PRODUCT NAME: NICKEL, 1000 PPM (0.100% W/V)
 FORMULA: NI IN HNO3
 FORMULA WT: 58.70
 CAS NO.: - -
 PRODUCT CODES: 6936
 EFFECTIVE: 09/03/86
 REVISION #02

PRECAUTIONARY LABELLING

BAKER SAF-T-DATA(TM) SYSTEM

HEALTH - 3 SEVERE (CANCER CAUSING)
 FLAMMABILITY - 0 NONE
 REACTIVITY - 1 SLIGHT
 CONTACT - 3 SEVERE (CORROSIVE)

HAZARD RATINGS ARE 0 TO 4 (0 = NO HAZARD; 4 = EXTREME HAZARD).

LABORATORY PROTECTIVE EQUIPMENT

GOGGLES & SHIELD; LAB COAT & APRON; VENT HOOD; PROPER GLOVES

PRECAUTIONARY LABEL STATEMENTS

POISON DANGER
 HARMFUL IF SWALLOWED OR INHALED
 CAUSES IRRITATION AND MAY CAUSE BURNS.
 CAUTION: CONTAINS NICKEL, CANCER HAZARD.

EXCEPTIONAL HEALTH AND CONTACT HAZARDS - READ MATERIAL SAFETY DATA SHEET
 DO NOT GET IN EYES, ON SKIN, ON CLOTHING.
 DO NOT BREATHE VAPOR. KEEP IN TIGHTLY CLOSED CONTAINER. USE WITH ADEQUATE
 VENTILATION. WASH THOROUGHLY AFTER HANDLING.

SAF-T-DATA(TM) STORAGE COLOR CODE: WHITE (CORROSIVE)

2 - HAZARDOUS COMPONENTS

COMPONENT	%	CAS NO.
NICKEL	0-1	7440-02-0
NITRIC ACID (0.3 MOLAR)	1-2	7697-37-2

3 - PHYSICAL DATA

BOILING POINT: 100 C (212 F) VAPOR PRESSURE(MM HG): N/A
 MELTING POINT: 0 C (32 F) VAPOR DENSITY(AIR=1): N/A

□

MSDS for NICKEL, 1000 PPM (0.100% W/V)

Page 2

SPECIFIC GRAVITY: 1.00
(H₂O=1)

EVAPORATION RATE: N/A
(BUTYL ACETATE=1)

SOLUBILITY (H₂O): COMPLETE (IN ALL PROPORTIONS) % VOLATILES BY VOLUME: 100

APPEARANCE & ODOR: CLEAR, PALE GREEN SOLUTION.

4 - FIRE AND EXPLOSION HAZARD DATA

FLASH POINT (OPEN CUP N/A NFPA 704M RATING: 3-0-0

FLAMMABLE LIMITS: UPPER - N/A % LOWER - N/A %

FIRE EXTINGUISHING MEDIA

USE EXTINGUISHING MEDIA APPROPRIATE FOR SURROUNDING FIRE.

SPECIAL FIRE-FIGHTING PROCEDURES

FIREFIGHTERS SHOULD WEAR PROPER PROTECTIVE EQUIPMENT AND SELF-CONTAINED BREATHING APPARATUS WITH FULL FACEPIECE OPERATED IN POSITIVE PRESSURE MODE.

TOXIC GASES PRODUCED

NITROGEN OXIDES

5 - HEALTH HAZARD DATA

THIS SUBSTANCE IS LISTED AS NTP ANTICIPATED HUMAN CARCINOGEN, IARC PROBABLE HUMAN CARCINOGEN (GROUPS 2A AND 2B).

THRESHOLD LIMIT VALUE (TLV/TWA): 1 MG/M3 (PPM)

PERMISSIBLE EXPOSURE LIMIT (PEL): 1 MG/M3 (PPM)

CARCINOGENICITY: NTP: YES IARC: YES Z LIST: NO OSHA REG: NO

EFFECTS OF OVEREXPOSURE

VAPORS MAY BE IRRITATING TO SKIN, EYES, AND MUCOUS MEMBRANES.
CONTACT WITH SKIN OR EYES MAY CAUSE SEVERE IRRITATION OR BURNS.
INGESTION MAY CAUSE IRRITATION AND BURNING TO MOUTH AND STOMACH.

TARGET ORGANS

NASAL CAVITIES, LUNGS, SKIN

MEDICAL CONDITIONS GENERALLY AGGRAVATED BY EXPOSURE

NONE IDENTIFIED

ROUTES OF ENTRY

INGESTION, INHALATION, EYE CONTACT, SKIN CONTACT

EMERGENCY AND FIRST AID PROCEDURES

CALL A PHYSICIAN.

IF SWALLOWED, DO NOT INDUCE VOMITING; IF CONSCIOUS, GIVE WATER, MILK, OR MILK OF MAGNESIA.

IF INHALED, REMOVE TO FRESH AIR. IF NOT BREATHING, GIVE ARTIFICIAL

□

MSDS for NICKEL, 1000 PPM (0.100% W/V)

Page 3

RESPIRATION. IF BREATHING IS DIFFICULT, GIVE OXYGEN.

IN CASE OF CONTACT, IMMEDIATELY FLUSH EYES OR SKIN WITH PLENTY OF WATER FOR AT LEAST 15 MINUTES WHILE REMOVING CONTAMINATED CLOTHING AND SHOES.

DOMESTIC (D.O.T.)

PROPER SHIPPING NAME	NITRIC ACID, 40% OR LESS SOLUTION
HAZARD CLASS	CORROSIVE MATERIAL (LIQUID)
UN/NA	NA1760
LABELS	CORROSIVE
REPORTABLE QUANTITY	1000 LBS.

INTERNATIONAL (I.M.O.)

PROPER SHIPPING NAME	NITRIC ACID, SOLUTION
HAZARD CLASS	8
UN/NA	UN2031
LABELS	CORROSIVE

□

Safety data for selenium

Synonyms:
Molecular formula: Se
CAS No: 7782492
EC No:

Physical data

Appearance: dark grey to dark red powder or crystals
Melting point: 144 C
Boiling point: 685 C
Vapour density:
Vapour pressure:
Specific gravity: 4.81
Flash point:
Explosion limits:
Autoignition temperature:

Stability

Stable. Incompatible with strong acids, strong oxidizing agents and most common metals.
Combustible.

Toxicology

Poison. Highly toxic - may be fatal if inhaled, ingested or absorbed through skin. IV-RAT
LD50 6 mg/kg. Irritant.

Personal protection

Safety glasses; gloves. Effective ventilation.

This information was last updated on December 22nd, 1997. We have tried to make it as accurate and useful as possible, but can take no responsibility for its use, misuse, or accuracy. We have not verified this information, and cannot guarantee that it is up-to-date.

Safety data for silver

General

Synonyms: Argentum, shell silver
Molecular formula: Ag
CAS No: 7440-22-4
EC No:

Physical data

Appearance: lustrous soft white metal
Melting point:
Boiling point:
Specific gravity:
Vapour pressure:
Flash point:
Explosion limits:
Autoignition temperature:

Stability

Stable. Substances to be avoided include strong acids and strong bases.

Toxicology

Solid silver presents few health hazards. Repeated long-term exposure to silver dust can cause permanent blue-grey staining of eyes, mouth, throat and skin, and may cause eye damage.

Personal protection

Safety glasses and effective ventilation if working with silver powder.

This information was last updated on September 15, 2000. Although we have tried to make it as accurate and useful as possible, we can take no responsibility for its use or misuse.

Safety data for thallium

Synonyms:
Molecular formula: Tl
CAS No: 7440280
EC No:

Physical data

Appearance: silver-grey metal, tarnishing quickly in air
Melting point: 302 C
Boiling point: 1457 C
Vapour density:
Vapour pressure:
Specific gravity: 11.85 g/cm³
Flash point:
Explosion limits:
Autoignition temperature:

Stability

Stable. [Used as pesticide, rodenticide, depilator.]

Toxicology

Very toxic by inhalation, ingestion and skin absorption. 14 mg/kg may be fatal. May act as a systemic poison. Neurotoxin. May cause birth abnormalities. Chronic ORL-RAT 4mth dose 0.45 mg/kg/day yielded 100% mortality. Respiratory and eye irritant. TLV 0.1 mg/m³ (soluble compounds). R26 R28 R33.

Personal protection

Safety glasses; rubber or plastic gloves. Good ventilation.

This information was last updated on February 10, 1998. We have tried to make it as accurate and useful as possible, but can take no responsibility for its use, misuse, or accuracy. We have not verified this information, and cannot guarantee that it is up-to-date.

Safety data for zinc

General

Synonyms: zinc dust, zinc powder, blue powder, granular zinc, zinc foil, LS 2, LS 6, merrillite
Molecular formula: Zn
CAS No: 7440-66-6
EC No: 231-175-3

Physical data

Appearance: silver or blueish-white foil or powder
Melting point: 420 C
Boiling point: 908 C
Vapour density:
Vapour pressure:
Density (g cm⁻³): 7.14
Flash point:
Explosion limits:
Autoignition temperature:
Water solubility:

Stability

Stable. Incompatible with amines, cadmium, sulfur, chlorinated solvents, strong acids, strong bases. Air and moisture sensitive. **Powder or dust is very flammable.**

Toxicology

May be harmful if swallowed or inhaled. May act as an irritant.

Toxicity data

(The meaning of any abbreviations which appear in this section is given [here](#).)

Risk phrases

(The meaning of any risk phrases which appear in this section is given [here](#).)
R15 R17.

Transport information

Non-hazardous for air, sea and road freight.

Personal protection

Do not breathe dust. Wear safety glasses if handling powdered zinc.

Safety phrases

(The meaning of any safety phrases which appear in this section is given here.)

S7 S8 S43.

[Return to [Physical & Theoretical Chemistry Lab. Safety home page](#).]

This information was last updated on October 19, 2000. We have tried to make it as accurate and useful as possible, but can take no responsibility for its use, misuse, or accuracy. We have not verified this information, and cannot guarantee that it is up-to-date.

Monsanto

Material Safety Data

Emergency Phone No.
(Call Collect)
636-674-1000

POLYCHLORINATED BIPHENYLS (PCBs)

1. CHEMICAL PRODUCT AND COMPANY IDENTIFICATION

PRODUCT NAME: POLYCHLORINATED BIPHENYLS (PCBs)
Aroclor® Series 1016, 1221, 1232, 1242, 1248, 1254, 1260, 1262, 1268
Therminol® FR Series

MSDS Number: M00018515

Date : 7/99

Chemical Family: Chlorinated Hydrocarbons
Chemical Name: Polychlorinated biphenyls
Synonyms: PCBs, Chlorodiphenyls, Chlorinated biphenyls

Trade Names/Common Names:

PYRANOL® and INERTEEN® are trade names for commonly used dielectric fluids that may have contained varying amounts of PCBs as well as other components including chlorinated benzenes.

ASKAREL is the generic name for a broad class of fire resistant synthetic chlorinated hydrocarbons and mixtures used as dielectric fluids that commonly contained about 30 - 70% PCBs. Some ASKAREL fluids contained 99% or greater PCBs and some contained no PCBs.

PYDRAUL® was the trade name for hydraulic fluids that, prior to 1972, may have contained varying amounts of PCBs and other components including phosphate esters.

The product names/trade names are representative of several commonly used Monsanto products (or products formulated with Monsanto products). Other trademarked PCB products were marketed by Monsanto and other manufacturers. PCBs were also manufactured and sold by several European and Japanese companies. Contact the manufacturer of the trademarked product, if not in this listing, to determine if the formulation contained PCBs.

In 1972, Monsanto restricted sales of PCBs to applications involving only closed electrical systems, (transformers and capacitors). In 1977, all manufacturing and sales were voluntarily terminated. In 1979, EPA restricted the manufacture, processing, use, and distribution of PCBs to specifically exempted and authorized activities.

FOR CHEMICAL EMERGENCY, SPILL, LEAK, FIRE, EXPOSURE, OR ACCIDENT
Call CHEMTREC - Day or Night - 1-800-424-9300 Toll free in the continental U.S., Hawaii, Puerto Rico, Canada, Alaska, or Virgin Islands. For calls originating elsewhere - 202-483-7616 (collect calls accepted)

For additional nonemergency information, call - 636-674-8558.

2. COMPOSITION/INFORMATION ON INGREDIENTS

Chemically, commercial PCBs are defined as a series of technical mixtures, consisting of many isomers and compounds that vary from mobile, oily liquids to white crystalline solids and hard noncrystalline resins. Technical products vary in composition, in the degree of chlorination, and possibly according to batch.

The mixtures generally used contain an average of 3 atoms of chlorine per molecule (42% chlorine) to 5 atoms of chlorine per molecule (54% chlorine). They were used as components of dielectric fluids in transformers and capacitors. Prior to 1972, PCB applications included heat transfer media, hydraulic, and other industrial fluids, plasticizers, carbonless copy paper, paints, inks, and adhesives.

<u>Component</u>	<u>CAS No.</u>
chlorinated biphenyl	1336-36-3
Aroclor 1016	12674-11-2
Aroclor 1221	11104-28-2
Aroclor 1232	11141-16-5
Aroclor 1242	53469-21-9
Aroclor 1248	12672-29-6
Aroclor 1254	11097-69-1
Aroclor 1260	11096-82-5
Aroclor 1262	37324-23-5
Aroclor 1268	11100-14-4

There are also CAS Numbers for individual PCB congeners and for mixtures of Aroclor® products.

PCBs are identified as hazardous chemicals under criteria of the OSHA Hazard Communication Standard (29 CFR Part 1910.1200). PCBs have been listed in the International Agency for Research on Cancer (IARC) Monographs (1987)-Group 2A and in the National Toxicology Program (NTP) Annual Report on Carcinogens (Eighth).

3. HAZARDS IDENTIFICATION

EMERGENCY OVERVIEW

Appearance and Odor: PCB mixtures range in form and color from clear to amber liquids to white crystalline solids. They have a mild, distinctive odor and are not volatile at room temperature. Refer to Section 9 for details.

WARNING!

**CAUSES EYE IRRITATION
MAY CAUSE SKIN IRRITATION**

PROCESSING AT ELEVATED TEMPERATURES MAY RELEASE VAPORS OR FUMES WHICH MAY CAUSE RESPIRATORY TRACT IRRITATION

POTENTIAL HEALTH EFFECTS

Likely Routes

of Exposure: Skin contact and inhalation of heated vapors

Eye Contact: Causes moderate irritation based on worker experience.

Skin Contact: Prolonged or repeated contact may result in redness, dry skin and defatting based on human experience. A potential exists for developing chloracne. PCBs can be absorbed through intact skin.

Inhalation: Due to the low volatility of PCBs, exposure to this material in ambient conditions is not expected to produce adverse health effects. However, at elevated processing temperatures, PCBs may produce a vapor that may cause respiratory tract irritation if inhaled based on human experience.

Ingestion: No more than slightly toxic based on acute animal toxicity studies. Coughing, choking and shortness of breath may occur if liquid material is accidentally drawn into the lungs during swallowing or vomiting.

MSDS#: M00018515

Other:

Numerous epidemiological studies of humans, both occupationally exposed and nonworker environmentally exposed populations, have not demonstrated any causal relationship between PCB exposure and chronic human illnesses such as cancer or neurological or cardiovascular effects. PCBs at high dosage can cause skin symptoms; however, these subside upon removal of the exposure source.

Refer to Section 11 for toxicological information.

4. FIRST AID MEASURES

IF IN EYES, immediately flush with plenty of water for at least 15 minutes. If easy to do, remove any contact lenses. Get medical attention. Remove material from skin and clothing.

IF ON SKIN, immediately flush the area with plenty of water. Wash skin gently with soap as soon as it is available. Get medical attention if irritation persists.

IF INHALED, remove person to fresh air. If breathing is difficult, get medical attention.

IF SWALLOWED, do NOT induce vomiting. Rinse mouth with water. Get medical attention. Contact a Poison Control Center. NEVER GIVE ANYTHING BY MOUTH TO AN UNCONSCIOUS PERSON

NOTE TO PHYSICIANS: Hot PCBs may cause thermal burn. If electrical equipment arcs between conductors, PCBs or other chlorinated hydrocarbon dielectric fluids may decompose to produce hydrochloric acid (HCl), a respiratory irritant. If large amounts are swallowed, gastric lavage may be considered.

5. FIRE FIGHTING MEASURES

Flash Point: 284 degrees F (140 degrees C) or higher depending on the chlorination level of the Aroclor product

Fire Point: 349 degrees F (176 degrees C) or higher depending on the chlorination level of the Aroclor product

NOTE: Refer to Section 9 for individual flash points and fire points.

Extinguishing

Media: Extinguish fire using agent suitable for surrounding fire. Use dry chemical, foam, carbon dioxide or water spray. Water may be ineffective. Use water spray to keep fire-exposed containers or transformers cool.

PCBs are fire-resistant compounds. They may decompose to form CO, CO₂, HCl, phenolics, aldehydes, and other toxic combustion products under severe conditions such as exposure to flame or hot surfaces.

Dielectric fluids having PCBs and chlorinated benzenes as components have been reported to produce polychlorinated dibenzo-p-dioxins (PCDDs) and furans (PCDFs) during fire situations involving electrical equipment. At temperatures in the range of 600-650 degrees C in the presence of excess oxygen, PCBs may form polychlorinated dibenzofurans (PCDFs). Laboratory studies under similar conditions have demonstrated that PCBs do not produce polychlorinated dibenzo-p-dioxins (PCDDs).

Federal regulations require all PCB transformers to be registered the U.S. Environmental Protection Agency.

If a PCB transformer is involved in a fire-related incident, the owner of the transformer may be required to report the incident. Consult and follow appropriate federal, state and local regulations.

Fire Fighting Equipment: Fire fighters and others exposed to products of combustion should wear self-contained breathing apparatus. Equipment should be thoroughly decontaminated after use.

MSDS #: M00018515

6. ACCIDENTAL RELEASE MEASURES

Cleanup and disposal of liquid PCBs and other PCB items are strictly regulated by the federal government. The regulations are found at 40 CFR Part 761. Consult these regulations as well as applicable state and local regulations prior to any cleanup or disposal of PCBs, PCB items, or PCB contaminated items.

If PCBs leak or are spilled, the following steps should be taken immediately:

All nonessential personnel should leave the leak or spill area.

The area should be adequately ventilated to prevent the accumulation of vapors.

The spill/leak should be contained. Loss to sewer systems, navigable waterways, and streams should be prevented. Spills/leaks should be removed promptly by means of absorptive material, such as sawdust, vermiculite, dry sand, clay, dirt or other similar materials, or trapped and removed by pumping or other suitable means (traps, drip-pans, trays, etc.).

Personnel entering the spill or leak area should be furnished with appropriate personal protective equipment and clothing as needed. Refer to Section 8 for personal protection equipment and clothing.

Personnel trained in emergency procedures and protected against attendant hazards should shut off sources of PCBs, clean up spills, control and repair leaks, and fight fires in PCB areas.

Refer to Section 13 for disposal information and Sections 14 and 15 for information regarding reportable quantity, and Section 7 for marking information.

7. HANDLING AND STORAGE

Care should be taken to prevent entry into the environment through spills, leakage, use vaporization, or disposal of liquid or containers. Avoid prolonged breathing of vapors or mists. Avoid contact with eyes or prolonged contact with skin. If skin contact occurs, remove by washing with soap and water. Following eye contact, flush with water. In case of spillage onto clothing, the clothing should be removed as soon as practical, skin washed, and clothing laundered. Comply with all federal, state, and local regulations.

Federal regulations under the Toxic Substances Control Act require PCBs, PCB items, storage areas, transformer vaults, and transport vehicles to be marked (check regulations, 40 CFR 761, for details).

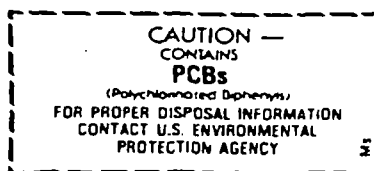
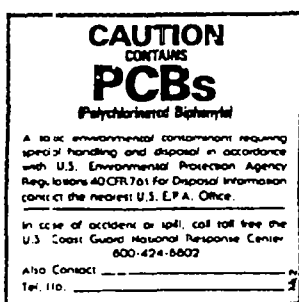

Storage: The storage of PCB items or equipment (those containing 50 ppm or greater PCBs) and PCB waste is strictly regulated by 40 CFR Part 761. The storage time is limited, the storage area must meet physical requirements, and the area must be labeled.

Avoid contact with eyes.

Wash thoroughly after handling.

Avoid breathing processing fumes or vapors.

Process using adequate ventilation.

MSDS #: M00018515

8. EXPOSURE CONTROLS/PERSONAL PROTECTION

Eye

Protection: Wear chemical splash goggles and have eye baths available where there is significant potential for eye contact.

Skin

Protection: Wear appropriate protective clothing and chemical resistant gloves to prevent skin contact. Consult glove manufacturer to determine the appropriate type glove for a given application. Wear chemical goggles, face shield, and chemical resistant clothing such as a rubber apron when splashing is likely. Wash immediately if skin is contacted. Remove contaminated clothing promptly and launder before reuse. Clean protective equipment before reuse. Provide a safety shower at any location where skin contact can occur. Wash thoroughly after handling.

ATTENTION! Repeated or prolonged skin contact may cause chloracne in some people.

Respiratory

Protection: Avoid breathing vapor, mist, or dust. Use NIOSH/MSHA approved equipment when airborne exposure limits are exceeded. Full facepiece equipment is recommended when airborne exposure limits are exceeded and, if used, replaces the need for face shield and/or chemical splash goggles. Consult respirator manufacturer to determine the type of equipment for a given application. The respirator use limitations specified by NIOSH/MSHA or the manufacturer must be observed. High airborne concentrations may require use of self-contained breathing apparatus or supplied air respirator. Respiratory protection programs must be in compliance with 29 CFR Part 1910.134.

ATTENTION! Repeated or prolonged inhalation may cause chloracne in some people.

Ventilation:

Provide natural or mechanical ventilation to control exposure levels below airborne exposure limits (see below). If practical, use local mechanical exhaust ventilation at sources of vapor or mist, such as open process equipment.

Airborne Exposure Limits:

Product: Chlorodiphenyl (42% chlorine)

OSHA PEL: 1 mg/m³ 8-hour time-weighted average - Skin*

ACGIH TLV: 1 mg/m³ 8-hour time-weighted average - Skin*

Product: Chlorodiphenyl (54% chlorine)

OSHA PEL: 0.5 mg/m³ 8-hour time-weighted average - Skin*

ACGIH TLV: 0.5 mg/m³ 8-hour time-weighted average - Skin*

*For Skin notation see Threshold Limit Values for Chemical Substances and Physical Agents and Biological Exposure Indices, American Conference of Government Industrial Hygienists, 1995-1996.

9. PHYSICAL AND CHEMICAL PROPERTIES

PROPERTIES OF SELECTED AROCLORS®

PROPERTY	1016	1221	1232	1242	1248	1254	1260
Color (APHA)	40	100	100	100	100	100	150
Physical state	mobile oil	mobile oil	mobile oil	mobile oil	mobile oil	viscous liquid	sticky resin
Stability	inert	inert	inert	inert	inert	inert	inert
Density (lb/gal 25 °C)	11.40	9.85	10.55	11.50	12.04	12.82	13.50
Specific gravity x/15.5°C	1.36-1.37 x-25°	1.18-1.19 x-25°	1.27-1.28 x-25°	1.30-1.39 x-25°	1.40-1.41 x-65°	1.49-1.50 x-65°	1.55-1.56 x-90°
Distillation range (°C)	323-356	275-320	290-325	325-366	340-375	365-390	385-420
Acidity mg KOH/g, maximum	.010	.014	.014	.015	.010	.010	.014
Fire point (°C)	none to boiling point	176	238	none to boiling point	none to boiling point	none to boiling point	none to boiling point
Flash point (°C)	170	141-150	152-154	176-180	193-196	none	none
Vapor pressure (mm Hg @ 100°F)	NA	NA	0.005	0.001	0.00037	0.00006	NA
Viscosity (Saybolt Univ. Sec. @ 100°F) (centistokes)	71-81 13-16	38-41 3.6-4.6	44-51 5.5-7.7	82-92 16-19	185-240 42-52	1800-2500 390-540	— —

NA-Not Available

NOTE: These physical data are typical values based on material tested but may vary from sample to sample. Typical values should not be construed as a guaranteed analysis of any specific lot or as specifications for the product.

10. STABILITY AND REACTIVITY

Stability: PCBs are very stable, fire-resistant compounds.

Materials to Avoid: None

Hazardous Decomposition:

Products: PCBs may decompose to form CO, CO₂, HCl, phenolics, aldehydes, and other toxic combustion products under severe conditions such as exposure to flame or hot surface.

Hazardous Polymerization: Does not occur.

11. TOXICOLOGICAL INFORMATION

Data from laboratory studies conducted by Monsanto and from the available scientific literature are summarized below. Single exposure (acute) studies indicate:

Oral - Slightly Toxic (Rat LD50 - 8.65 g/kg for 42% chlorinated; 11.9 g/kg for 54% chlorinated)

MSDS #: M00018515

The liquid products and their vapors are moderately irritating to eye tissues. Animal experiments of varying duration and at different air concentrations show that for similar exposure conditions, the 54% chlorinated material produces more liver injury than the 42% chlorinated material.

There are literature reports that PCBs can impair reproductive functions in laboratory monkeys. Literature reports of earlier chronic feeding studies of laboratory rodents provided sufficient evidence that Aroclor 1260 could cause liver cancer when fed at high doses. Similar experiments with less chlorinated PCB products produced negative or equivocal results. A recent literature report of a chronic feeding study of Aroclor 1260, Aroclor 1254, Aroclor 1242, and Aroclor 1016 provided evidence that all four mixtures caused cancer in rodent livers.

The consistent finding in animal studies is that PCBs produce liver injury following prolonged and repeated exposure by any route, if the exposure is of sufficient degree and duration. Liver injury is produced first, and by exposures that are less than those reported to cause cancer in rodents. Therefore, exposure by all routes should be kept sufficiently low to prevent liver injury.

Numerous epidemiological studies of humans, both occupationally exposed and nonworker environmentally exposed populations, have not demonstrated any causal relationship between PCB exposure and chronic human illnesses such as cancer or neurological or cardiovascular effects. PCBs at high dosage can cause skin symptoms; however, these subside upon removal of the exposure source.

PCBs have been listed in the International Agency for Research on Cancer (IARC) Monographs (1987)-Group 2A and in the National Toxicology Program (NTP) Eighth Annual Report on Carcinogens.

12. ECOLOGICAL INFORMATION

Care should be taken to prevent entry of PCBs into the environment through spills, leakage, use, vaporization or disposal of liquid or solids. PCBs can accumulate in the environment and can adversely affect some animals and aquatic life. In general, PCBs have low solubility in water, are strongly bound to soils and sediments, and are slowly degraded by natural processes in the environment.

13. DISPOSAL CONSIDERATIONS

The disposal of PCB items or equipment (those containing 50 ppm or greater PCBs) and PCB wastes is strictly regulated by 40 CFR Part 761. For example, all wastes and residues containing PCBs (wiping cloths, absorbent material, used disposable protective gloves and clothing, etc.) should be collected, placed in proper containers, marked and disposed of in the manner prescribed by EPA regulations (40 CFR Part 761) and applicable state and local regulations.

14. TRANSPORT INFORMATION

The data provided in this section are for information only. Please apply the appropriate regulations to properly classify a shipment for transportation.

DOT Classification:	IF WEIGHT OF PCBs TO BE SHIPPED IS OVER ONE POUND, THE FOLLOWING CLASSIFICATION AND LABEL APPLY.
DOT Label:	LIQUID: Environmentally Hazardous Substance, liquid, n.o.s. (Contains PCB), 9, UN 3082, III
	SOLID: Environmentally Hazardous Substance, solid, n.o.s. (Contains PCB), 9, UN 3077, III
DOT Label:	Class 9
DOT Reportable Quantity:	One pound
IMO Classification:	Polychlorinated Biphenyls, IMO Class 9, UN 2315, II IMO Page 9034, EMS 6.1-02
IATA/ICAO Classification:	Polychlorinated Biphenyls, 9, UN2315,II

MSDS #: M00012515

15. REGULATORY INFORMATION

For regulatory purposes, under the Toxic Substances Control Act, the term "PCBs" refers to a chemical substance limited to the biphenyl molecule that has been chlorinated to varying degrees or any combination of substances which contain such a substance (40 CFR Part 761).

TSCA Inventory: not listed.

Hazard Categories Under Criteria of SARA Title III Rules (40 CFR Part 370): Immediate, Delayed.

SARA Section 313 Toxic Chemical(s): Listed-1993 (De Minimis concentration 0.1%.)

Reportable Quantity (RQ) under DOT (49 CFR), CERCLA Regulations and TSCA (40 CFR Part 761): 1 lb. (polychlorinated biphenyls) PCBs.

Release of more than 1 (one) pound of PCBs to the environment requires notification to the National Response Center (800-424-8802 or 202-426-2675).

Various state and local regulations may require immediate reporting of PCB spills and may also define spill cleanup levels. Consult your attorney or appropriate regulatory officials for information relating to spill reporting and spill cleanup.

16. OTHER INFORMATION

Reason for revision: Company name change. Spinoff of company businesses. Supersedes MSDS dated 12/95.

Therminol® is a registered trademark of Solutia Inc.
Aroclor® and Pydraul® were registered trademarks of Monsanto Company
Pyranol® is a registered trademark of General Electric Company
Inerteen® is a registered trademark of Westinghouse Electric Corporation

FOR ADDITIONAL NONEMERGENCY INFORMATION, CONTACT:

Robert G. Kaley, II
Director, Environmental Affairs

Solutia Inc.
575 Maryville Centre Drive
P. O. Box 66760
St. Louis, MO 63166-6760
(636)674-8558

Formerly the chemical businesses
of Monsanto Company

Although the information and recommendations set forth herein (hereinafter "Information") are presented in good faith and believed to be correct as of the date hereof, Solutia Inc. makes no representations as to the completeness or accuracy thereof. Information is supplied upon the condition that the persons receiving same will make their own determination as to its suitability for their purposes prior to use. In no event will Solutia Inc. be responsible for damages of any nature whatsoever resulting from the use of or reliance upon Information. NO REPRESENTATIONS OR WARRANTIES, EITHER EXPRESS OR IMPLIED, OF MERCHANTABILITY, FITNESS FOR A PARTICULAR PURPOSE OR OF ANY OTHER NATURE ARE MADE HEREUNDER WITH RESPECT TO INFORMATION OR THE PRODUCT TO WHICH INFORMATION REFERS.

APPENDIX C

**Occupational Safety and Health Administration
Supplementary Record of
Occupational Injuries and Illnesses**

U.S. Department of Labor



This form is required by Public Law 91-596 and must be kept in the establishment for 5 years.
Failure to maintain can result in the issuance of citations and assessment of penalties.

Case or File No.

Form Approved
O.M.B. No. 1218-0176

Employer

1. Name

2. Mail address (No. and street, city or town, State, and zip code)

3. Location, if different from mail address

See OMB Disclosure
Statement on reverse.

Injured or Ill Employee

4. Name (First, middle, and last)

Social Security No.

5. Home address (No. and street, city or town, State, and zip code)

6. Age

7. Sex (Check one)

Male

Female

8. Occupation (Enter regular job title, not the specific activity he was performing at the time of injury.)

9. Department (Enter name of department or division in which the injured person is regularly employed, even though he may have been temporarily working in another department at the time of injury.)

The Accident or Exposure to Occupational Illness

If accident or exposure occurred on employer's premises, give address of plant or establishment in which it occurred. Do not indicate department or division within the plant or establishment.

If accident occurred outside employer's premises at an identifiable address, give that address. If it occurred on a public highway or at any other place which cannot be identified by number and street, please provide place references locating the place of injury as accurately as possible.

10. Place of accident or exposure (No. and street, city or town, State, and zip code)

11. Was place of accident or exposure on employer's premises?

Yes

No

12. What was the employee doing when injured? (Be specific. If he was using tools or equipment or handling material, name them and tell what he was doing with them.)

13. How did the accident occur? (Describe fully the events which resulted in the injury or occupational illness. Tell what happened and how it happened. Name any objects or substances involved and tell how they were involved. Give full details on all factors which led or contributed to the accident. Use separate sheet for additional space.)

Occupational Injury or Occupational Illness

14. Describe the injury or illness in detail and indicate the part of body affected. (E.g., amputation of right index finger at second joint; fracture of ribs; lead poisoning; dermatitis of left hand, etc.)

15. Name the object or substance which directly injured the employee. (For example, the machine or thing he struck against or which struck him; the vapor or poison he inhaled or swallowed; the chemical or radiation which irritated his skin; or in cases of strains, hernias, etc., the thing he was lifting, pulling, etc.)

16. Date of injury or initial diagnosis of occupational illness

17. Did employee die? (Check one)

Yes

No

Other

18. Name and address of physician

19. If hospitalized, name and address of hospital

Date of report

Prepared by/

Official position

APPENDIX D

APPENDIX E

APPENDIX F

APPENDIX G

MINIRAM STANDARD OPERATING PROCEDURES

MINI-RAM AEROSOL MONITOR

The MINIRAM is used for monitoring particulate concentrations in air. A direct read-out in mg/m^3 is obtained to indicate airborne concentrations of particulate.

Summary of Method

The MINIRAM is held in the breathing zone to obtain a direct reading in mg/m^3 of particulate matter.

Equipment

MINIRAM with charger or batteries.

Procedure

1. To start the monitoring operation of the MINIRAM, Press MEAS. The first readout displayed is either "GO" followed by the last concentration reading or ".00".
2. Approximately 36 seconds after pressing MEAS the first new 10-second-averaged concentration reading is displayed. Subsequent readings are concentration values in milligrams per cubic meter, updated every 10 seconds.
3. The MINIRAM will now run in the measurement mode for 500 minutes (8 hours and 20 minutes), after which it will stop, displaying the OFF reading, retaining in storage the concentration average and elapsed time information. Once the MEAS mode has been entered this sequence can only be interrupted by pressing OFF; pressing ZERO, TWA, SA, TIME or ID# only affects the display during the time these keys are pressed, without affecting the measurement cycle. Pressing the PBK during this cycle has no effect.
4. The instrument normally operates in the .00 to $9.99 \text{ mg}/\text{m}^3$ range. Whenever a 10-second concentration exceeds $9.99 \text{ mg}/\text{m}^3$ the MINIRAM display automatically switches to the .0 to $99.99 \text{ mg}/\text{m}^3$ range and remains in that range as long as the measured 10-second concentration exceeds $9.99 \text{ mg}/\text{m}^3$, otherwise the MINIRAM reverts to its lower range display.

Calibration

Field calibration of the MINI-RAM will not be conducted. The instrument should be maintained as described in the manufacturer's specifications.