

01-0161

**PHASE I - LIMITED SITE INVESTIGATION/
CURRENT ASSESSMENT SUMMARY REPORT
HILL 78 AREA, PITTSFIELD, MASSACHUSETTS**

**VOLUME II
Appendices**

RECEIVED

SEP 11 1991

**BERKSHIRE COUNTY
REGIONAL PLANNING COMMISSION**

Prepared for

**General Electric Company
100 Woodlawn Avenue
Pittsfield, Massachusetts 01201**

September 1991

**Geraghty & Miller, Inc.
24 Madison Avenue Extension
Albany, New York 12203
(518) 452-7826**

LIST OF APPENDICES

- A. Hill 78 Area Supplemental Data Summary.
- B. Aerial Photographs.
- C. Hill 78 Topographic Maps.
- D. Existing Drainage Site Plan, Hill 78, December 1990.
- E. Utilities Plans.
- F. Pittsfield Zoning Map.
- G. Generator Annual Report.
- H. Soil Boring and Well Construction Logs.
- I. Report on Soil Boring Program for Altresco Tree Plantings and Analytical Results.
- J. Surface Soil Sample Analytical Report.
- K. Preliminary Assessment Report.
- L. Interim Site Classification Form.



APPENDIX A

HILL 78 SUPPLEMENTAL DATA SUMMARY

HILL 78 AREA
MCP PHASE
SUPPLEMENTAL DATA SUMMARY

General Electric Company
Pittsfield, Massachusetts

May 1990



BLASLAND & BOUCK ENGINEERS, P.C.
BLASLAND, BOUCK & LEE
ENGINEERS & GEOSCIENTISTS

GE PITTSFIELD HILL 78 AREA
MCP PHASE I SCOPE OF WORK
SUPPLEMENTAL DATA SUMMARY

TABLE OF CONTENTS

	<u>Page</u>
SECTION 1 - INTRODUCTION	
1.1 General	1-1
1.2 Format of Document	1-1
1.3 Background Information	1-1
SECTION 2 - SOIL BORING PROGRAMS	
2.1 General	2-1
2.2 Hill 78 Fill Area	2-2
2.2.1 Soil Boring Program Description	2-2
2.2.2 Analytical Results	2-2
2.3 Altresco Area	2-3
2.3.1 Soil Boring Program Description	2-3
2.3.2 Analytical Results	2-4
2.4 Altresco Parking Area	2-6
2.4.1 Soil Boring Program Description	2-6
2.4.2 Analytical Results	2-7
2.5 Altresco Steamline Supports	2-7
2.5.1 Soil Boring Program Description	2-7
2.5.2 Analytical Results	2-7
2.6 New York Avenue Water Line	2-8
2.6.1 Soil Boring Program Description	2-8
2.6.2 Analytical Results	2-8
2.7 Altresco Transmission Line	2-9
2.7.1 Soil Boring Program Description	2-9
2.7.2 Analytical Results	2-9
SECTION 3 - SITE HYDROGEOLOGY AND GROUND-WATER CHARACTERISTICS	
3.1 General	3-1
3.2 Ground-Water Flow	3-1
3.3 Ground-Water Quality	3-1

TABLES

Table 1 - Summary of PCB Analyses - Hill 78 Fill Area	
Table 2 - Summary of PID Field Screening - Altresco Area (April through June 1987)	
Table 3 - Summary of PCB Analyses - Altresco Area (July 1987)	
Table 4 - Summary of PID Field Screening - Altresco Area (August 1988)	
Table 5 - Summary of Volatile Organic Compounds Detected in Soil Samples - Altresco Area (August 1988)	

GE PITTSFIELD HILL 78 AREA
MCP PHASE I SCOPE OF WORK
SUPPLEMENTAL DATA SUMMARY

TABLE OF CONTENTS
(Cont'd)

TABLES (Cont'd.)

- Table 6 - Summary of PCBs Detected in Altresco Area (February/March 1989)
- Table 7 - Summary of PCB Analyses - Altresco Parking Area
- Table 8 - Summary of PCB Analyses - Altresco Steamline Supports
- Table 9 - Summary of PCB Analyses - New York Avenue Water Line
- Table 10 - Summary of PCB Analyses - Altresco Transmission Line
- Table 11 - Summary of Ground-Water Analyses - New York Avenue

REFERENCES

FIGURES

- Figure 1 - Site Plan
- Figure 2 - Ground-Water Flow Map

APPENDICES

- Appendix A - Geologic Boring Logs

SECTION 1 - INTRODUCTION

1.1 General

This document has been prepared to supplement the Hill 78 Area - MCP Phase I Scope of Work.

The Hill 78 Area is currently defined by the Massachusetts Department of Environmental Protection (DEP) as being in Phase I - Limited Site Investigation of the MCP process. This DEP classification indicates that the available site-related data is sufficient to fulfill the Preliminary Assessment phase of the MCP process, but does not provide a large enough database to fulfill Phase I requirements. This document provides a summary of available information, including past and present land use, physical characteristics and results of subsurface investigations.

1.2 Format of Document

Following a summary of background information, this Supplemental Data Summary presents the soil boring programs and methods of investigation that were used in the Hill 78 Area subsurface investigations in Section 2. Methods of investigation include soil boring installation, soil sampling techniques, monitoring well installation, and ground-water sampling techniques. Section 3 includes a discussion of site hydrogeology and ground-water characteristics.

1.3 Background Information

The Hill 78 Area MCP Phase I study area is located in a central location in reference to the entire GE facility. The study area is generally bounded by Merrill Road on the south, New York Avenue on the west, the

Tyler Street extension on the north, and the fence of the western side of Building OP-2 to the east, as illustrated on Figure 1.

Within the Hill 78 Area are the Hill 78 fill area itself, the Altresco Cogeneration Facility, the Building 78 Hazardous Waste Drum Storage facility, and the Building 71 PCB Drum Storage facility. The Building 78 facility is regulated through GE's Resource Conservation and Recovery Act (RCRA) Part B Permit, while the Building 71 facility is regulated through GE's Toxic Substance Control Act (TSCA) permit.

The Hill 78 fill area has been utilized by General Electric since the early 1940s for the disposal of plant demolition debris and other non-hazardous solid materials. Items such as concrete, asphalt, bricks, and steel were routinely disposed of in this area as facility demolition/upgrade projects were performed. It is reported that during the 1950s and 1960s, drums containing PCBs adsorbed to fullers earth may have been disposed of in the fill area. The fill area is relatively flat in its center portions with steep embankments along its northern edge. Access to the fill area is restricted to General Electric personnel and contractors and is controlled via perimeter fencing and secured access gates with television surveillance.

In the last decade, the materials placed within the fill area have included excess soils from plant-wide excavations and snow removed from the entire plant area. Only those soils containing less than 50 ppm of PCBs were considered for placement within the Hill 78 fill area. Recently, at the DEP's request, General Electric has discontinued the practice of placing soils or other solid materials from the plant onto the Hill 78 fill area and has submitted a proposal for interim storage of these materials at an alternate location. In further response to the DEP's request, GE is proposing to

develop and implement a cover plan to minimize on-site exposure while maintaining the area's use for snow disposal.

The Altresco Cogeneration facility is currently being constructed within the Hill 78 study area. During the preliminary phases of construction, a soil boring program was conducted (in 1989) to assist in location of the facility. In addition, several water production wells have been drilled to a depth of several hundred feet within the Hill 78 study area to furnish the cogeneration facility with a source of cooling water. Analytical data collected from the soil boring and well installation programs is described in Section 2.

SECTION 2 - SOIL BORING PROGRAMS

2.1 General

Between 1987 and 1989, a number of soil boring programs within the Hill 78 Area (Figure 1) have been performed. The study area, for the purpose of facilitating the presentation of the data, has been subdivided into six areas. These sub-areas are:

- Hill 78 Fill Area;
- Altresco Area;
- Altresco Steamline Support;
- New York Avenue Waterline;
- Altresco Parking Area; and
- Altresco Transmission Line.

The purpose of the soil boring programs was to determine the nature and extent of fill deposits in the Hill 78 fill area and in the remaining areas referenced above. The soil boring programs were initiated to determine if the soils contained PCBs or volatile organic compounds (VOCs) prior to the initiation of any excavation activities at the site.

All soil borings were drilled using a hollow stem auger rig and soil samples were collected by use of a split-spoon core barrel sampler. For each sub-area, the number and depths of the borings varied. A more detailed description of the soil boring programs is provided in the subsequent sections of this report.

2.2 Hill 78 Fill Area

2.2.1 Soil Boring Program Description

In this area a total of 16 soil borings were drilled between April 13 and April 20, 1987. All of the borings were drilled to a depth 20 feet below land surface and split-spoon soil samples were collected every two feet from land surface to the bottom of the boring (Figure 1). Although borings B-10, B-11, and B-12 are located in this area, they were drilled during the Altresco area investigation and are discussed in more detail in Section 2.3.

Twelve of the 16 borings drilled in this area encountered fill deposits, the four borings that did not encounter fill are B-1, B-2, B-10, and B-11. These borings are located on the southern edge of the area just outside of the fill zone (Figure 1). The fill is described as being composed primarily of sand and gravel with intermixed cement, glass, bricks, wood, metal, and ceramic debris. The thickness of the fill ranges from four feet at Boring B-5 to greater than 20 feet at Boring B-4. None of the geologic logs indicate the presence of buried drums, oil staining, or any chemical odors in the samples (Reference 2).

Below the fill (where present), the natural deposits are described as a fine silty sand near the surface and grading into a medium-course sand and gravel with depth. The geologic logs for these borings are provided in Appendix A.

2.2.2 Analytical Results

As part of the soil boring program, a total of 153 soil samples were collected for laboratory analysis of PCB content. The results of the soil sampling revealed that out of the 153 soil samples analyzed, 91 of the samples indicated detectable PCB concentrations while 26

contained PCBs at a concentration of greater than 50 parts per million (ppm). These 26 samples were collected from ten borings (B-4, 5, 6, 7, 8, 9, 12, 13, 15, and 16). For the most part, these samples were collected from 0 to 12 feet below land surface; the only samples that were collected from greater depths, which contained PCBs at levels greater than 50 ppm, were from Borings B-4 and B-12. A summary of the analytical results is presented on Table 1, and the boring locations are shown on Figure 1.

2.3 Altresco Area

2.3.1 Soil Boring Program Description

A total of 41 soil borings were drilled in this area. In addition, four shallow borings (zero to two feet) were drilled for the purpose of collecting shallow soil samples for PCB analysis. The borings were drilled between 1987 and 1989. The depths of the borings ranged from 4 to 20 feet below land surface (Reference 2).

Eight of the soil borings (72-1, 2, 4, 17, 28, 29, 30, and 32) encountered fill deposits ranging from one-foot thick at Boring 72-30 to 14-feet thick at Boring 72-2 (Figure 1). The fill is described as a sandy silt with some gravel and clay with intermixed wood, metal, and bricks. At Boring 72-1, an oil sheen was observed on the soils within the fill zone.

Below the fill (where present) and at the remainder of the area, the natural deposits are described as a fine silty sand near the surface and grading into a medium-coarse sand and gravel with depth. The geologic logs for this area are provided in Appendix A.

2.3.2 Analytical Results

From April to June 1987, 21 soil borings were drilled in this area. Borings B-10, 11, and 14, although located in the Hill 78 fill area, were drilled at this time. The results for the PCB analysis on soil samples from Borings B-10, 11, and 14 are presented in Table 1. At each location, split-spoon samples were collected at two-foot intervals, described in detail, wrapped in aluminum foil, and placed in zip-lock plastic bags. Each sample was screened in the field for the presence of VOCs by using an HNU photoionization meter. Elevated VOC vapors were detected in samples from Borings 72-1, 72-4, 72-5, 72-6, and 72-11. The results of the field screening are provided on Table 2. Each individual two-foot core sample was delivered to the on-site GE laboratory for analysis of PCBs (Table 3). PCBs were not detected above 35 ppm in any of the soil samples collected in the Altresco Area except in Boring 72-3 and 72-4 in which PCBs were detected at higher concentrations (Table 3).

During August 1988, a total of seven soil borings was drilled to a depth of eight feet (Boring 72-19 through 72-25) in the Altresco Area (Figure 1). The boring locations and depths were selected based on photoionization results for soil samples collected during June 1987 and recommendations by GE. In addition, three borings were drilled to a depth of four feet at the June 1987 soil boring locations 72-5, 72-6, and 72-11 in an attempt to verify previous high photoionization detector results. Additional boring numbers were not used to identify these locations. Similar four-foot borings (72-26 and 72-27) were drilled at locations between the June 1987 Borings 72-1 and 72-2, and Borings 72-4 and 72-3, respectively.

At each boring location, split-spoon samples were collected continuously at two-foot intervals and screened in the field for VOCs. The results of the field screenings are provided on Table 4. Soil samples collected from Borings 72-19 through 72-25 were composited as follows: split-spoon samples collected from 0 to 2 feet and 2 to 4 feet were composited as one sample (0 to 4 feet) for each borehole, and split-spoon samples collected from 4 to 6 feet and 6 to 8 feet were composited as a second sample (4 to 8 feet) for each borehole. A total of 14 composited soil samples were analyzed for priority pollutant VOCs (Table 5).

The analytical results for the soil samples indicate that methylene chloride was the only compound detected above the detection limit. The concentrations of methylene chloride ranged from 5.0 to 11.0 ppb (Table 5). It should be noted that methylene chloride is a typical laboratory contaminant and that these results may represent contamination due to the laboratory.

During February 1989, soil boring programs were conducted in three areas within the Altresco Area (Reference 2). The purpose of the programs was to determine whether PCBs were present in the soil prior to initiating excavation activities.

During February 1989, soil Borings 72-28 through 72-36 and shallow Borings B-1 through B-4 were drilled in the Altresco Area (Figure 1). Boring depths ranged from 2 to 12 feet below land surface. At Borings 72-28 through 72-32, split-spoon samples were collected continuously at 2-foot intervals, described in detail, composited into three 4-foot samples (0 to 4 feet, 4 to 8 feet, 8 to 12 feet) and analyzed by the laboratory for PCB content (Table 6). At Borings 72-33 through 72-36, split-spoon

samples were collected continuously and composited into three samples (0 to 2 feet, 2 to 6 feet, 6 to 10 feet) and analyzed for PCBs. The results of the analyses indicated that of the 39 samples collected, 19 of the samples had detectable PCBs, and that only 1 sample (72-28, 0 to 4 feet) contained PCBs above 50 ppm, (51 ppm). The remaining soil samples ranged in concentrations from less than 0.05 ppm to 20 ppm (Table 6).

Soil Borings B-1 through B-4 were drilled to two feet below grade and a two-foot soil sample was collected from each boring for PCB analysis (Figure 1). Of the four samples collected, none contained PCBs above 50 ppm (Table 6).

During March 1989, soil borings (72-40 through 72-44) were drilled in the Altresco Area (Figure 1). At each of the five soil boring locations, split-spoon samples were collected continuously at two-foot intervals to a depth of eight feet below land surface, composited into four-foot samples (zero to four feet and four to eight feet) and analyzed by the laboratory for PCB content. The results of the analyses indicated that PCBs were not present in any of the samples above 0.60 ppm (Table 6).

2.4 Altresco Parking Area

2.4.1 Soil Boring Program Description

In October 1989, a total of 20 soil borings were drilled along the perimeter fence that encloses the Altresco parking area (Figure 1). All of the borings were drilled to a depth of eight feet below grade and split-spoon samples collected every two feet from land surface to the bottom of the boring.

Borings B-2 through B-16 encountered 1.5 inches of asphalt underlain by up to eight feet of a predominately silt and sand fill but also containing a trace of gravel. Below the fill unit are natural sand and gravel deposits. At Borings B-17 through B-21, no fill or asphalt was encountered. The shallow soils consisted of three inches of topsoil underlain by sand and gravel.

2.4.2 Analytical Results

At each boring four-foot composite samples were collected (zero to four and four to eight) and submitted to the laboratory for analyses of PCB content (Table 7). Of the 40 samples analyzed, only 2 contained PCBs above the detection limit. These concentrations are 12.0 and 5.3 ppm and were collected at Boring B-20, zero to four feet and Boring B-11, zero to four feet, respectively (Table 7).

2.5 Altresco Steamline Supports

2.5.1 Soil Boring Program Description

A total of 25 soil borings were drilled for the foundation holes for the Altresco steamline supports within the Hill 78 Area (Figure 1). As part of this program a total of 41 soil samples were collected and submitted to the laboratory for analysis of PCB content.

2.5.2 Analytical Results

The results of the analysis showed that only one sample contained PCBs above 50 ppm; this sample was collected at Boring PS-W-26B (four to eight feet) and contained PCBs at 53 ppm (Reference 2). The remainder of the samples ranged in PCB content from non-detect to 38 ppm (Table 8).

In addition to the PCB analysis, two soil samples were analyzed for priority pollutant volatile organic compounds. These samples were collected from PS-W-25B (four to eight feet) and PS-W-24 (zero to four feet). The analysis detected methylene chloride in both samples at 7.0 parts per billion (ppb) and 13.0 ppb and toluene at 4.0 ppb and 5.0 ppb, respectively.

2.6 New York Avenue Water Line

2.6.1 Soil Boring Program Description

Between October 3 and December 4, 1989, Geraghty & Miller drilled seven borings (WL-1 through WL-7) in the Hill 78 Area for the New York Avenue water line (Figure 1). The depths of these ranged from seven to eight feet below land surface. Split-spoon samples were collected every two feet from land surface to the bottom of the boring. The soils are described as fine-medium sand with some gravel and occasional lenses of silt and fine sand mixed in (Reference 2).

2.6.2 Analytical Results

At each boring, composite soil samples were collected for laboratory analysis of PCB content. The depths of each composite were dependent on the final depth of the borehole (Table 9). A total of 14 soil samples were analyzed for PCBs and the only two samples in which PCBs were detected above 50 ppm were collected from Boring WL-4 at zero to four feet and four to eight feet. PCBs were detected in these samples at 53 and 67 ppm, respectively. The remainder of the samples contained PCB concentrations ranging from less than 1.0 ppm to 20 ppm (Table 9).

2.7 Altresco Transmission Line

2.7.1 Soil Boring Program Description

On November 14 and 15, 1989, Geraghty & Miller drilled 15 soil borings in the area of the Altresco transmission line (Figure 1). The borings were drilled to a depth varying from four to ten feet below land surface. Split-spoon soil samples were collected every two feet from land surface to the bottom of the boring. The geology is described as predominately a silty fine sand with layers of silt and medium sand mixed in (Reference 2).

2.7.2 Analytical Results

All soil samples collected for the boring program were screened in the field with a photoionization detector for the presence of VOCs. All of the soil samples screened were non-detectable levels of VOCs (see geologic logs for readings - Appendix A). A total of 39 composite soil samples were collected for laboratory analysis of PCB content. The results show that two of the samples contained PCBs at a concentration greater than 50 ppm. These samples were STR-2N, zero to two feet and STR-15, zero to four feet. The concentration of PCBs in these samples was 430 ppm and 190 ppm, respectively. The remainder of the samples ranged in PCB content from less than 1.0 ppm to 21 ppm (Table 10).

SECTION 3 - SITE HYDROGEOLOGY AND GROUND-WATER CHARACTERISTICS

3.1 General

There are presently four shallow monitoring wells and four deep water supply wells located within the Hill 78 Area. Shallow monitoring wells NY-1 through NY-4 were installed between April 25 and May 2, 1988 by Geraghty & Miller. These wells are located on the western portion of the site along Merrill Road and the Tyler Street Extension (Figure 1). The depths of the wells ranges from 14 to 33 feet below land surface and are used to monitor shallow ground-water quality.

On the eastern portion of the site, Altresco has installed four deep bedrock supply wells to support facility operations in the area. Two of these wells are abandoned and a third is not in use at this time (Figure 1).

3.2 Ground-Water Flow

Water level measurements were collected from shallow monitoring wells NY-1 through NY-4 on June 24, 1988. A ground-water contour map, based on water levels in the four shallow wells (NY-1 through NY-4), was prepared. Figure 2 illustrates that the shallow ground-water flow at the site is toward the south-southeast. Hydrogeologic information from the deep Altresco water supply wells is not available at this time.

3.3 Ground-Water Quality

Between April 27 and May 11, 1988, the shallow monitoring wells NY-1 through NY-4 were sampled (Reference 2). These samples were analyzed for the full priority pollutant list of compounds. The results of the analyses indicated that the only constituents present above the detection limit were

phenol in Well NY-1 at 75 parts per billion (ppb), cyanide in Well NY-2 at 0.73 ppb, and trace levels of zinc in Wells NY-1, NY-3, and NY-4 (Table 11).

On January 11, 1989, Blasland & Bouck sampled the ground water from Altresco Well No. 3 and submitted it for priority pollutant analysis (Figure 1). The results of this sampling indicated the presence of toluene at a concentration of 150 ppb and zinc at 17.0 ppb.

On August 10, 1989, Geraghty & Miller sampled the ground water from Altresco Well No. 3. This sample was collected during a 500 gallon per minute pump test, 70 hours from commencement. The sample was collected from the end of the effluent pipe located on New York Avenue and analyzed for the complete priority pollutant list of constituents. The results of this analysis indicated detectable concentrations of trichlorethene at 4.0 ppb and copper at 40.0 ppb.



Tables

TABLE 1

HILL 78 AREA
 GENERAL ELECTRIC COMPANY
 PITTSFIELD, MASSACHUSETTS

SUMMARY OF PCB ANALYSES - HILL 78 FILL AREA (PPM)

Boring	Depth in Feet Below Land Surface									
	0-2	2-4	4-6	6-8	8-10	10-12	12-14	14-16	16-18	18-20
B-1	<1.0	16	<1.0	<1.0	<1.0	<1.0	<1.0	<1.0	<1.0	<1.0
B-2	17	32	34	1.0	--	5.0	1.0	1.0	<1.0	1.0
B-3	9.0	15	10	22	6.0	--	<1.0	9.0/7.0	8.0	4.0
B-4	2.0	--	74	49	12	30	2.0	3.0	57	52
B-5	52	361	53	99	83	9.0	<1.0	<1.0	<1.0	<1.0
B-6	35	32	18	969/128	10	4.0	<1.0	<1.0	<1.0	<1.0
B-7	5.0	<1.0	4.0	12	55	84	<1.0	<1.0	<1.0	<1.0
B-8	105	2.0	--	29	100	54	4.9	<1.0	<1.0	<1.0
B-9	11	17	--	73	17	37	1.0	<1.0	<1.0	<1.0
B-10	35	<1.0	--	<1.0	<1.0	<1.0	<1.0	<1.0	<1.0	<1.0
B-11	<1.0	<1.0	<1.0	<1.0	<1.0	<1.0	<1.0	--	1.0	1.0
B-12	1.0	<1.0	35	12	33	359	47,385	301	1,159	8.0
B-13	6.0	9.0	82	143	--	30	<1.0	<1.0	<1.0	1.0
B-14	2.0	--	6.0	<1.0	3.0	1.0	<1.0	<1.0	2.0	<1.0
B-15	92	10	232	57	15	10	558	<1.0	<1.0	<1.0
B-16	20	56	11	5.0	<1.0	<1.0	--	<1.0	<1.0	<1.0

Note:

-- = No sample

TABLE 2

HILL 78 AREA
 GENERAL ELECTRIC COMPANY
 PITTSFIELD, MASSACHUSETTS

SUMMARY OF PID FIELD SCREENING - ALTRESCO AREA
(PPM, APRIL THROUGH JUNE 1987)

Boring	Depth in Feet Below Land Surface									
	0-2	2-4	4-6	6-8	8-10	10-12	12-14	14-16	16-18	18-20
72-1	10	NR	480	290	630	260	200	40	11	9
72-2	NR	3.1	2.1	2.5	2.0	2.0	5.3	2.2	2.2	2.3
72-3	2.5	1.5	1.6	1.6	1.5	2.0	1.9	2.2	1.9	NR
72-4	145	180	1,100	280	1,720	500	300	250	455	485
72-5	225	218	201	204	NR	210	163	180	210	205
72-6	174	174	195	230	280	175	170	340	168	169
72-7	0.9	1.1	0.8	0.9	0.6	1.0	0.8	0.7	1.1	NR
72-8	1.2	1.2	0.8	0.9	0.9	0.8	0.6	1.1	0.6	1.3
72-9	0.6	0.7	11.4	0.4	0.7	0.4	0.5	0.4	0.7	0.8
72-10	0.4	0.5	4.4	1.0	1.0	0.9	0.6	0.7	1.2	1.0
72-11	253	1.1	350	210	1.2	1.2	1.3	1.1	NR	0.8
72-12	0.6	0.6	0.4	0.7	0.6	0.7	0.6	0.8	0.8	0.8
72-13	0.6	0.4	2.6	0.5	0.9	0.5	0.6	0.6	1.9	1.0
72-14	0.5	0.4	0.8	0.3	0.7	0.5	0.5	0.4	0.4	0.6
72-15	0.6	0.9	0.9	0.8	0.9	.08	0.8	NR	0.6	0.9
72-16	0.7	0.8	1.9	NR	0.5	0.8	0.5	0.5	0.6	0.7
72-17	0.4	NR	0.6	2.1	1.0	0.9	0.9	0.8	0.8	0.8
72-18	0.1	0.2	0.2	0.1	0.1	0.2	0.2	0.2	0.2	0.2

(See notes on page 2)

TABLE 2
(Cont'd.)

HILL 78 AREA
GENERAL ELECTRIC COMPANY
PITTSFIELD, MASSACHUSETTS

SUMMARY OF PID FIELD SCREENING - ALTRESCO AREA
(PPM, APRIL THROUGH JUNE 1987)

Boring	Depth in Feet Below Land Surface									
	<u>0-2</u>	<u>2-4</u>	<u>4-6</u>	<u>6-8</u>	<u>8-10</u>	<u>10-12</u>	<u>12-14</u>	<u>14-16</u>	<u>16-18</u>	<u>18-20</u>
B-10	ND	ND	NR	ND	ND	ND	ND	ND	ND	ND
B-11	ND	ND	ND	ND	ND	ND	ND	NR	ND	ND
B-14	ND	ND	ND	ND	ND	ND	ND	ND	ND	ND

Notes:

NR = No Recovery
ND = Not Detected

These values are qualitative only and do not represent the absolute concentrations of any volatile organic compounds.

TABLE 3

HILL 78 AREA
 GENERAL ELECTRIC COMPANY
 PITTSFIELD, MASSACHUSETTS

SUMMARY OF PCB ANALYSES - ALTRESCO AREA (PPM DRY WEIGHT, JULY 1987)

Boring	Depth in Feet Below Land Surface									
	0-2	2-4	4-6	6-8	8-10	10-12	12-14	14-16	16-18	18-20
72-1	663	--	447	378	1,231	224	644	35	12	9.0
72-2	--	27	<1.0	<1.0	<1.0	2.0	<1.0	<1.0	<1.0	<1.0
72-3	95	<1.0	<1.0	<1.0	<1.0	<1.0	<1.0	<1.0	<1.0	--
72-4	12	13	3,931	16,067	5,844	18,741	917	348	331	3,206
72-5	<1.0	<1.0	9.0	<1.0	--	2.0	<1.0	<1.0	<1.0	<1.0
72-6	<1.0	<1.0	<1.0	<1.0	--	<1.0	<1.0	<1.0	<1.0	<1.0
72-7	<1.0	<1.0	<1.0	<1.0	<1.0	<1.0	<1.0	<1.0	<1.0	--
72-8	<1.0	<1.0	<1.0	<1.0	<1.0	<1.0	<1.0	<1.0	<1.0	<1.0
72-9	<1.0	<1.0	47	<1.0	--	<1.0	<1.0	<1.0	<1.0	<1.0
72-10	<1.0	<1.0	<1.0	<1.0	--	<1.0	<1.0	<1.0	<1.0	<1.0
72-11	<1.0	<1.0	<1.0	<1.0	<1.0	<1.0	<1.0	<1.0	--	<1.0
72-12	<1.0	<1.0	<1.0	<1.0	<1.0	<1.0	<1.0	<1.0	<1.0	<1.0
72-13	<1.0	<1.0	<1.0	<1.0	<1.0	<1.0	<1.0	<1.0	<1.0	<1.0
72-14	<1.0	<1.0	<1.0	<1.0	<1.0	<1.0	<1.0	<1.0	<1.0	<1.0
72-15	<1.0	<1.0	<1.0	<1.0	<1.0	<1.0	<1.0	--	<1.0	<1.0
72-16	<1.0	<1.0	<1.0	--	<1.0	<1.0	<1.0	<1.0	<1.0	<1.0
72-17	<1.0	--	<1.0	<1.0	<1.0	<1.0	<1.0	<1.0	<1.0	<1.0
72-18	<1.0	<1.0	<1.0	<1.0	<1.0	<1.0	<1.0	<1.0	<1.0	<1.0

Note:

-- = No sample

TABLE 4

HILL 78 AREA
 GENERAL ELECTRIC COMPANY
 PITTSFIELD, MASSACHUSETTS

SUMMARY OF PID FIELD SCREENING
- ALTRESCO AREA (PPM, AUGUST 1988)

<u>Boring</u>	<u>Depth in Feet Below Land Surface</u>			
	<u>0-2</u>	<u>2-4</u>	<u>4-6</u>	<u>6-8</u>
72-19	0.8	0.9	0.6	0.5
72-20	1.0	0.6	0.5	0.9
72-21	0.8	1.0	0.5	0.3
72-22	1.7	0.7	1.5	0.6
72-23	0.5	0.5	0.6	0.8
72-24	0.2	0.2	0.3	0.2
72-25	0.6	0.5	0.7	0.7
72-26	0.6	0.5		
72-27	0.5	0.9		
72-5	0.6	0.5		
72-6	0.2	0.3		
72-11	0.4	1.4		

Note:

These values are qualitative only and do not represent the absolute concentrations of any volatile organic compounds.

TABLE 5

HILL 78 AREA
 GENERAL ELECTRIC COMPANY
 PITTSFIELD, MASSACHUSETTS

SUMMARY OF VOLATILE ORGANIC COMPOUNDS DETECTED
IN SOIL SAMPLES - ALTRESCO AREA (AUGUST 1988)

<u>Sample I.D.</u>	<u>Compound</u>	<u>Concentration (ppb)</u>
72-19, 0-4'	methylene chloride	6.0
	toluene	<5.0
72-19, 4-8'	methylene chloride	7.0
	toluene	<5.0
	trichloroethene	<5.0
72-20, 0-4'	methylene chloride	11.0
	toluene	<5.0
72-20, 4-8'	trans-1,2-dichloroethene	<5.0
	methylene chloride	9.0
	toluene	<5.0
	trichloroethene	<5.0
72-21, 0-4'	methylene chloride	9.0
72-21, 4-8'	methylene chloride	5.0
	toluene	<5.0
72-22, 0-4'	methylene chloride	8.0
	toluene	<5.0
72-22, 4-8'	methylene chloride	7.0
72-23, 0-4'	methylene chloride	8.0
72-23, 4-8'	methylene chloride	9.0
72-24, 0-4'	methylene chloride	10.0
72-24, 4-8'	methylene chloride	6.0
72-25, 0-4'	methylene chloride	8.0
	toluene	<5.0
	trichlorethene	5.0
72-25, 4-8'	methylene chloride	6.0

Notes:

Quantitation limit = 5 ppb.

< = detected but at a level less than the quantitation limit.

TABLE 6

HILL 78 AREA
 GENERAL ELECTRIC COMPANY
 PITTSFIELD, MASSACHUSETTS

SUMMARY OF PCBs DETECTED IN ALTRESCO AREA (FEBRUARY/MARCH 1989)

<u>Boring</u>	<u>Sample Depth (ft)</u>	<u>Total PCBs (ppm dry weight)</u>
72-28	0-4	51
	4-8	2.7
	8-12	20
72-29	0-4	3.6
	4-8	3.7
	8-12	<0.05
72-30	0-4	0.13
	4-8	<0.05
72-31	0-4	0.08
	4-8	<0.05
72-32	0-4	7.7
	4-8	16
	8-12	0.05
72-33	0-2	<0.05
	2-6	<0.05
	6-10	<0.05
72-34	0-2	<0.05
	2-6	<0.05
	6-10	<0.05
72-35	0-2	<0.05
	2-6	<0.05
	6-10	<0.05
72-36	0-2	<0.05
	2-6	<0.05
	6-10	<0.05
72-40	0-4	0.60
	4-8	<0.05
72-41	0-4	0.42
	4-8	0.21
72-42	0-4	0.11
	4-8	<0.05

TABLE 6
(Cont'd.)

HILL 78 AREA
GENERAL ELECTRIC COMPANY
PITTSFIELD, MASSACHUSETTS

SUMMARY OF PCBs DETECTED IN ALTRESCO AREA (FEBRUARY/MARCH 1989)

<u>Boring</u>	<u>Sample Depth (ft)</u>	<u>Total PCBs (ppm dry weight)</u>
72-43	0-4	<0.05
	4-8	<0.05
72-44	0-4	0.08
	4-8	<0.05
B-1	0-2	45
B-2	0-2	3.6
B-3	0-2	7.0
B-4	0-2	24

TABLE 7

HILL 78 AREA
 GENERAL ELECTRIC COMPANY
 PITTSFIELD, MASSACHUSETTS

SUMMARY OF PCB ANALYSES - ALTRESCO PARKING AREA

<u>Boring</u>	<u>Depth (feet)</u>	<u>Total PCBs (ppm dry weight)</u>
B2	0-4	<1
	4-8	<1
B3	0-4	<1
	4-8	<1
B4	0-4	<1
	4-8	<1
B5	0-4	<1
	4-8	<1
B6	0-4	<1
	4-8	<1
B7	0-4	<1
	4-8	<1
B8	0-4	<1
	4-8	<1
B9	0-4	<1
	4-8	<1
B10	0-4	<1
	4-8	<1
B11	0-4	5.3
	4-8	<1
B12	0-4	<1
	4-8	<1
B13	0-4	<1
	4-8	<1
B14	0-4	<1
	4-8	<1
B15	0-4	<1
	4-8	<1

TABLE 7
(Cont'd.)

HILL 78 AREA
GENERAL ELECTRIC COMPANY
PITTSFIELD, MASSACHUSETTS

SUMMARY OF PCB ANALYSES - ALTRESCO PARKING AREA

<u>Boring</u>	<u>Depth (feet)</u>	<u>Total PCBs (ppm dry weight)</u>
B16	0-4	<1
	4-8	<1
B17	0-4	<1
	4-8	<1
B18	0-4	<1
	4-8	<1
B19	0-4	<1
	4-8	<1
B20	0-4	12
	4-8	<1
B21	0-4	<1
	4-8	<1

TABLE 8

HILL 78 AREA
 GENERAL ELECTRIC COMPANY
 PITTSFIELD, MASSACHUSETTS

SUMMARY OF PCB ANALYSIS - ALTRESCO STEAMLINE SUPPORTS

<u>Sample #</u>	<u>Sample Depth (ft)</u>	<u>Total PCBs (ppm dry weight)</u>
PS-W-1A	0-4	0.45
PS-W-1B	4-8	<0.05
PS-W-3A	0-4	2.8
PS-W-3B	4-8	0.08
PS-W-5A	0-4	20
PS-W-5B	4-8	0.07
PS-W-7A	0-2	1.6
PS-W-7B	2-6	0.08
PS-W-7C	6-10	<0.05
PS-W-9A	0-4	0.65
PS-W-9B	4-8	0.20
PS-W-11A	0-4	2.4
PS-W-11B	4-8	0.35
PS-W-13A	0-4	8.6
PS-W-13B	4-8	0.61
PS-W-15A	0-4	22
PS-W-15B	4-8	5.5
PS-W-17A	0-2	8.4
PS-W-17B	2-6	0.36
PS-W-17C	6-10	<0.05
PS-W-17D	10-14	<0.05
PS-W-18A	0-2	4.7
PS-W-18B	2-6	<0.05
PS-W-18C	6-10	<0.05
PS-W-18D	10-14	0.13
PS-W-22A	0-2	28
PS-W-22B	2-6	16
PS-W-22C	6-10	0.38
PS-W-26A	0-4	38
PS-W-26B	4-8	53
PS-W-30A	0-4	37
PS-W-30B	4-8	38
PS-W-34A	0-4	16
PS-W-34B	4-8	2.0
PS-W-38A	0-4	2.0
PS-W-38B	4-8	0.20
PS-W-42A	0-4	5.9
PS-W-42B	4-8	0.11

TABLE 9

HILL 78 AREA
GENERAL ELECTRIC COMPANY
PITTSFIELD, MASSACHUSETTSSUMMARY OF PCB ANALYSES - NEW YORK AVENUE WATER LINE

<u>Sample #</u>	<u>Depth (feet)</u>	<u>Total PCBs (ppm)</u>
WL-1	0-3	17
WL-1	3-5	11
WL-2	0-3	12
WL-2	3-7	<1.0
WL-3	0-3	10
WL-3	3-7	<1.0
WL-4	0-4	53
WL-4	4-8	67
WL-5	0-4	10
WL-5	4-8	<1.0
WL-6	0-4	20
WL-6	4-8	<1.0
WL-7	0-4	8.3
WL-7	4-8	<1.0

TABLE 10

HILL 78 AREA
 GENERAL ELECTRIC COMPANY
 PITTSFIELD, MASSACHUSETTS

SUMMARY OF PCB ANALYSES - ALTRESCO TRANSMISSION LINE

<u>Sample #</u>	<u>Depth (feet)</u>	<u>Total PCBs (ppm dry weight)</u>
STR-2N	0-2	430
	2-6	2.5
	6-10	8.2
STR-1N	0-2	4.2
	2-6	<1.0
	6-10	<1.0
STR-2S	0-4	<1.0
STR-1S	0-4	190
STR-4S1	0-4	<1.0
STR-3S	0-2	2.4
	2-6	<1.0
	6-10	<1.0
STR-3S1	0-2	15
	2-6	<1.0
	6-10	<1.0
STR-3S2	0-2	5.3
	2-6	<1.0
	6-10	<1.0
STR-4S	0-2	21
	2-6	<1.0
	6-10	<1.0
STR-3N	0-2	4.2
	2-6	<1.0
	6-10	<1.0
STR-3N1	0-2	1.7
	2-6	<1.0
	6-10	<1.0
STRN-3N2	0-2	4.4
	2-6	<1.0
	6-10	<1.0

TABLE 10
(Cont'd.)

HILL 78 AREA
GENERAL ELECTRIC COMPANY
PITTSFIELD, MASSACHUSETTS

SUMMARY OF PCB ANALYSES - ALTRESCO TRANSMISSION LINE

<u>Sample #</u>	<u>Depth (feet)</u>	<u>Total PCBs (ppm dry weight)</u>
STR-4S2	0-2	5.1
	2-6	<1.0
	6-10	<1.0
STR-4N	0-2	12
	2-6	<1.0
	6-10	<1.0
STR-4N2	0-2	1.8
	2-6	<1.0
	6-10	<1.0

TABLE 11

HILL 78 AREA
 GENERAL ELECTRIC COMPANY
 PITTSFIELD, MASSACHUSETTS

SUMMARY OF GROUND-WATER ANALYSES - NEW YORK AVENUE

Constituent	Well Designation:	NY-1	NY-2	NY-3/NY-R*	NY-4
	Date Sampled:	4/27/88	4/27/88	5/11/88	5/11/88
	Detection				
	Limit (ppb)	(ppb)	(ppb)	(ppb/ppb)	(ppb)
<u>Volatile Organic Compound</u>					
Acrolein	10	ND	ND	ND/ND	ND
Acrylonitrile	10	ND	ND	ND/ND	ND
Benzene	5	ND	ND	ND/ND	ND
Bromodichloromethane	5	ND	ND	ND/ND	ND
Bromoform	5	ND	ND	ND/ND	ND
Bromomethane	10	ND	ND	ND/ND	ND
Carbon tetrachloride	5	ND	ND	ND/ND	ND
Chlorobenzene	5	ND	ND	ND/ND	ND
Chloroethane	10	ND	ND	ND/ND	ND
2-Chloroethylvinyl ether	10	ND	ND	ND/ND	ND
Chloroform	5	<5	ND	ND/ND	ND
Chloromethane	10	ND	ND	ND/ND	ND
1,1-Dichloroethane	5	ND	ND	ND/ND	ND
1,2-Dichloroethane	5	ND	ND	ND/ND	ND
1,1-Dichloroethene	5	ND	ND	ND/ND	ND
Trans-1,2-Dichloroethene	5	ND	ND	ND/ND	ND
1,2-Dichloropropane	5	ND	ND	ND/ND	ND
cis-1,3-Dichloropropane	5	ND	ND	ND/ND	ND
Ethyl benzene	5	ND	ND	ND/ND	ND
Methylene chloride	5	ND	ND	ND/ND	ND
1,1,2,2-Tetrachloroethane	5	ND	ND	ND/ND	ND
Tetrachloroethene	5	ND	ND	ND/ND	ND
Toluene	5	ND	ND	ND/ND	ND
1,1,1-Trichloroethane	5	ND	ND	ND/ND	ND
1,1,2-Trichloroethane	5	ND	ND	ND/ND	ND
Trichloroethene	5	ND	ND	ND/ND	ND
Vinyl Chloride	10	ND	ND	ND/ND	ND

(See page 5 for notes).

TABLE 11
(Cont'd.)

HILL 78 AREA
GENERAL ELECTRIC COMPANY
PITTSFIELD, MASSACHUSETTS

SUMMARY OF GROUND-WATER ANALYSES - NEW YORK AVENUE

Constituent	Well Designation:	NY-1	NY-2	NY-3/NY-R*	NY-4
	Date Sampled:	4/27/88	4/27/88	5/11/88	5/11/88
	Detection				
	Limit (ppb)	(ppb)	(ppb)	(ppb/ppb)	(ppb)
<u>Base/Neutrals</u>					
Acenaphthene	10	ND	ND	ND	ND
Acenaphthylene	10	ND	ND	ND	ND
Anthracene	10	ND	ND	ND	ND
Benzidine	50	ND	ND	ND	ND
Benzo(a)anthracene	10	ND	ND	ND	ND
Benzo(b)fluoranthene	10	ND	ND	ND	ND
Benzo(k)fluoranthene	10	ND	ND	ND	ND
Benzo(a)pyrene	10	ND	ND	ND	ND
Benzo(g,h,i)perylene	10	ND	ND	ND	ND
Benzyl butyl Phthalate	10	ND	ND	ND	ND
Bis(2-chloroethoxy)methane	10	ND	ND	ND	ND
Bis(2-chloroethyl)ether	10	ND	ND	ND	ND
Bis(2-chloroisopropyl)ether	10	ND	ND	ND	ND
Bis(2-ethylhexyl)phthalate	10	ND	ND	ND	<10
4-Bromophenyl phenyl ether	10	ND	ND	ND	ND
2-Chloronaphthalene	10	ND	ND	ND	ND
4-Chlorophenyl phenyl ether	10	ND	ND	ND	ND
2-Chloronaphthalene	10	ND	ND	ND	ND
4-Chlorophenyl ether	10	ND	ND	ND	ND
Chrysene	10	ND	ND	ND	ND
Dibenzo(a,h)anthracene	10	ND	ND	ND	ND
Di-n-butyl phthalate	10	ND	ND	ND	<10
1,2-Dichlorobenzene	10	ND	ND	ND	ND
1,3-Dichlorobenzene	10	ND	ND	ND	ND
1,4-Dichlorobenzene	10	ND	ND	ND	ND
3,3-Dichlorobenzidine	20	ND	ND	ND	ND
Diethyl phthalate	10	ND	ND	ND	ND
Dimethyl phthalate	10	ND	ND	ND	ND
2,4-Dinitrotoluene	10	ND	ND	ND	ND
2,6-Dinitrotoluene	10	ND	ND	ND	ND
Di-n-octyl phthalate	10	ND	ND	ND	ND
1,2-diphenylhydrazine*	10	ND	ND	ND	ND
Fluoranthene	10	ND	ND	ND	ND
Fluorene	10	ND	ND	ND	ND

(See page 5 for notes).

TABLE 11
(Cont'd.)

HILL 78 AREA
GENERAL ELECTRIC COMPANY
PITTSFIELD, MASSACHUSETTS

SUMMARY OF GROUND-WATER ANALYSES - NEW YORK AVENUE

Constituent	Well Designation: Date Sampled: Detection Limit (ppb)	NY-1 4/27/88 (ppb)	NY-2 4/27/88 (ppb)	NY-3/NY-R* 5/11/88 (ppb/ppb)	NY-4 5/11/88 (ppb)
<u>Base/Neutrals</u> (Cont'd.)					
Hexachlorobenzene	10	ND	ND	ND	ND
Hexachlorobutadiene	10	ND	ND	ND	ND
Hexachlorocyclopentadiene	10	ND	ND	ND	ND
Hexachloroethane	10	ND	ND	ND	ND
Indeno(1,2,3-c,d)pyrene	10	ND	ND	ND	ND
Isophorone	10	ND	ND	ND	ND
Naphthalene	10	ND	ND	ND	ND
Nitrobenzene	10	ND	ND	ND	ND
n-Nitrosodimethylamine	10	ND	ND	ND	ND
n-Nitrosodi-n-propylamine	10	ND	ND	ND	ND
n-Nitrosodiphenylamine **	10	ND	ND	ND	ND
Phenanthrene	10	ND	ND	ND	<10
Pyrene	10	ND	ND	ND	ND
1,2,4-Trichlorobenzene	10	ND	ND	ND	ND
<u>Acid Extractables</u>					
4-Chloro-3-methylphenol	10	ND	ND	ND	ND
2-Chlorophenol	10	ND	ND	ND	ND
2,4-Dichlorophenol	10	ND	ND	ND	ND
2,4-Dimethylphenol	10	ND	ND	ND	ND
2,4-Dinitrophenol	50	ND	ND	ND	ND
2-Methyl-4,6-dinitrophenol	50	ND	ND	ND	ND
2-Nitrophenol	10	ND	ND	ND	ND
4-Nitrophenol	10	ND	ND	ND	ND
Pentachlorophenol	10	ND	ND	ND	ND
Phenol	10	75	ND	ND	ND
2,4,6-Trichlorophenol	10	ND	ND	ND	ND
<u>Metals and Indicator Parameters</u>					
Antimony		<0.03	<0.03	<0.03	<0.03
Arsenic		<0.03	<0.03	<0.03	<0.03
Beryllium		<0.001	<0.001	<0.001	<0.001
Cadmium		<0.005	<0.005	<0.005	<0.005
Chromium		<0.01	<0.01	<0.01	<0.01
Copper		<0.01	<0.01	<0.01	<0.01

(See page 5 for notes).

TABLE 11
(Cont'd.)

HILL 78 AREA
GENERAL ELECTRIC COMPANY
PITTSFIELD, MASSACHUSETTS

SUMMARY OF GROUND-WATER ANALYSES - NEW YORK AVENUE

Constituent	Well Designation: Date Sampled: Detection Limit (ppb)	NY-1 4/27/88 (ppb)	NY-2 4/27/88 (ppb)	NY-3/NY-R* 5/11/88 (ppb/ppb)	NY-4 5/11/88 (ppb)
<u>Metals and Indicator Parameters</u> (Cont'd.)					
Lead		<0.03	<0.03	<0.03	<0.03
Mercury		<0.001	<0.001	<0.001	<0.001
Nickel		<0.02	<0.02	<0.02	<0.02
Selenium		<0.06	<0.06	<0.06	<0.06
Silver		<0.005	<0.005	<0.005	<0.005
Thallium		<0.1	<0.1	<0.1	<0.1
Zinc		0.022	<0.005	0.036	0.006
Cyanide		<0.01	0.73	<0.01	<0.01
Phenols		<0.01	<0.01	<0.01	<0.01
<u>Pesticides and PCBs</u>					
Aldrin		<0.5	<0.5	<0.5	<1.1
Alpha-BHC		<0.5	<0.5	<0.5	<0.5
Beta-BHC		<0.5	<0.5	<0.5	<0.5
Gmm-BHC (Lindane)		<0.5	<0.5	<0.5	<0.5
Delta-BHC		<0.5	<0.5	<0.5	<0.5
Chlordane		<1.0	<1.0	<1.0	<4.2
4,4'-DDT		<0.5	<0.5	<0.5	<0.5
4,4'-DDE		<1.1	<1.1	<0.5	<0.5
4,4'-DDD		<0.5	<0.5	<0.5	<0.5
Dieldrin		<0.5	<0.5	<0.5	<0.7
Endosulfan I		<0.5	<0.5	<0.5	<0.5
Endosulfan II		<0.5	<0.5	<0.5	<0.5
Endrin		<0.5	<0.5	<0.5	<0.5
Endrin aldehyde		<1.0	<1.0	<1.0	<1.0
Heptachlor		<0.5	<0.5	<0.5	<1.1
Heptachlor epoxide		<0.5	<1.0	<0.5	<0.5

(See page 5 for notes).

TABLE 11
(Cont'd.)

HILL 78 AREA
GENERAL ELECTRIC COMPANY
PITTSFIELD, MASSACHUSETTS

SUMMARY OF GROUND-WATER ANALYSES - NEW YORK AVENUE

Constituent	Well Designation: Date Sampled: Detection Limit (ppb)	NY-1 4/27/88 (ppb)	NY-2 4/27/88 (ppb)	NY-3/NY-R* 5/11/88 (ppb/ppb)	NY-4 5/11/88 (ppb)
<u>Pesticides and PCBs</u> (Cont'd.)					
PCB-(Aroclor)-1242		<1.0	<1.0	<1.0	<3.6
PCB-(Aroclor)-1254		<1.0	<1.0	<1.0	<1.0
PCB-(Aroclor)-1221		<1.0	<1.0	<1.0	<1.0
PCB-(Aroclor)-1232		<1.0	<1.0	<1.0	<2.6
PCB-(Aroclor)-1248		<1.0	<1.0	<1.0	<2.5
PCB-(Aroclor)-1260		<1.0	<1.0	<1.0	<1.0
PCB-(Aroclor)-1016		<1.0	<1.0	<1.0	<2.7
Toxaphene		<1.0	<1.0	<1.0	<3.4

Notes:

* Replicate sample

ND Not detected.

< Compound detected but at a level less than the detection limit.



References

REFERENCES

1. Transmitted to S. Joyce, DEP from G. Grant Bowman, with October 27, 1989, cover letter.
2. Transmitted to S. Joyce, DEP from G. Grant Bowman, January 1990.



Figures

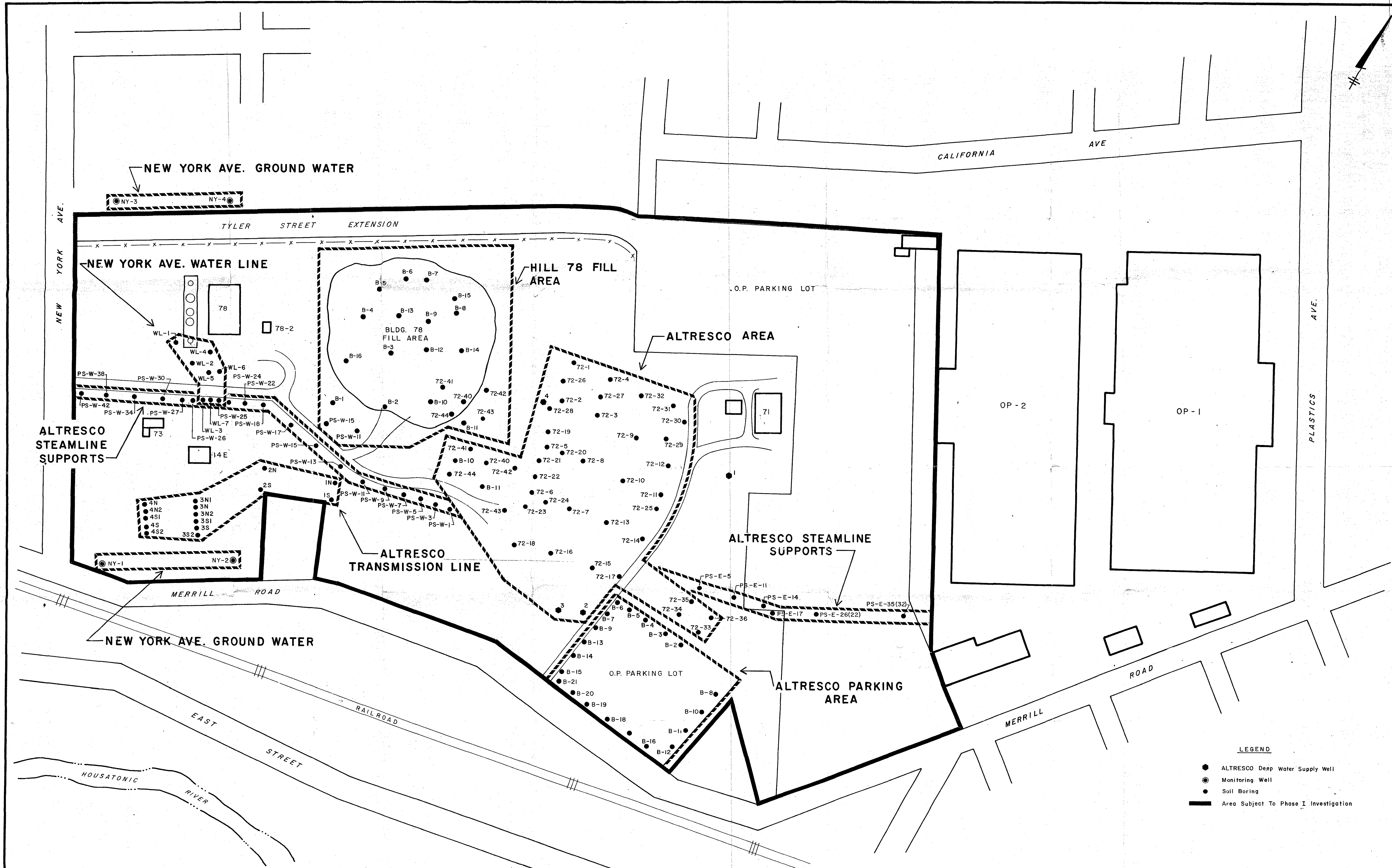

- LEGEND**
- ALTRESKO Deep Water Supply Well
 - ⊙ Monitoring Well
 - Soil Boring
 - ▭ Area Subject To Phase I Investigation

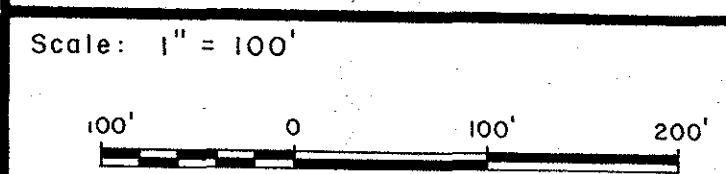

No.	Date	Checked by

NO ALTERATION PERMITTED HEREON EXCEPT AS PROVIDED UNDER SECTION 7209 SUBDIVISION 2 OF THE NEW YORK STATE EDUCATION LAW

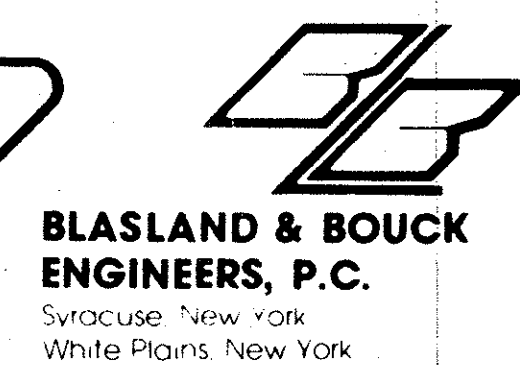

GENERAL ELECTRIC COMPANY • PITTSFIELD, MA
 MCP PHASE I - HILL 78 AREA
SITE PLAN

File Number 101.94.16	Figure 1
Date MAY 1990	

FIGURE 2



LEGEND

- 980' — GROUND-WATER CONTOUR ELEVATION LINE (DASHED WHERE INFERRED)
- ← GROUND-WATER FLOW DIRECTION
- MONITORING WELL
- (950.50) GROUND-WATER ELEVATION
- HILL 78 AREA BOUNDARY

SOURCE: GERAGHTY & MILLER, INC., CONFIGURATION OF THE WATER TABLE - JUNE 24, 1988.

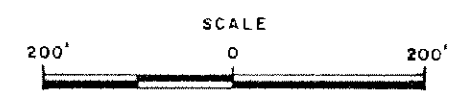

GENERAL ELECTRIC COMPANY
PITTSFIELD, MASSACHUSETTS

MCP PHASE I - HILL 78

GROUND-WATER CONTOUR
MAP JUNE 1988



BLASLAND & BOUCK ENGINEERS, P.C.
ENGINEERS & GEOSCIENTISTS

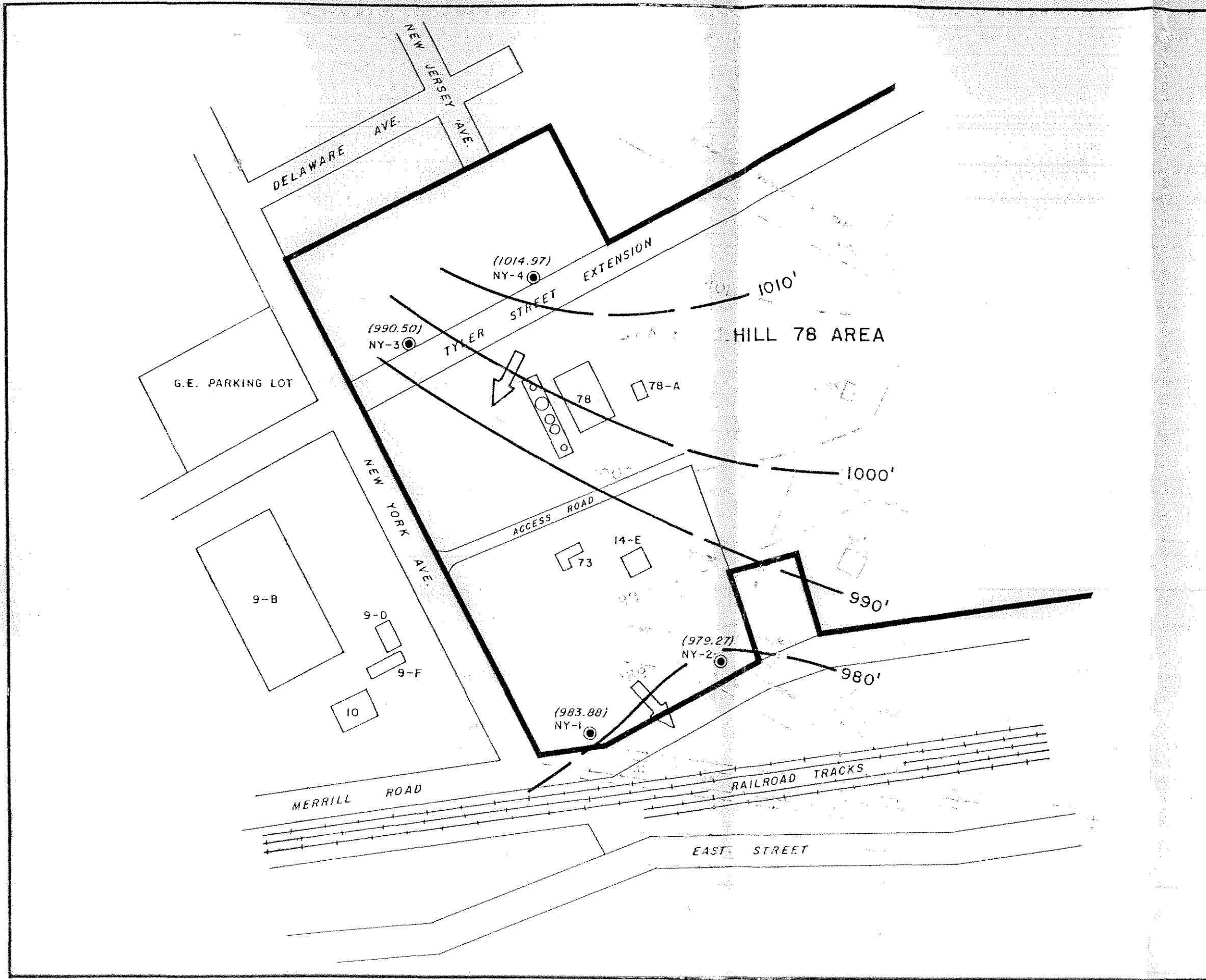



Appendices

FILL AREA

BORING/WELL: B-1 PROJECT NO: N0360SS1 PAGE: 1
 SITE: General Electric Co. DRILLING 4/13/87 DRILLING 4/13/87
 LOCATION: Pittsfield, MA (Bldg 78) STARTED: 15:10 COMPLETED: 17:00
 TOTAL DEPTH DRILLED: 20 ft HOLE DIAMETER: 5-3/4 in TYPE OF SAMPLE/
 CORING DEVICE: Split Spoon
 LENGTH & DIAMETER OF CORING DEVICE: 3' x 3" SAMPLING INTERVAL: 2 ft
 LAND-SURFACE ELEVATION: () SURVEYED () ESTIMATED DATUM:
 DRILLING FLUID USED: None DRILLING METHOD: Hollow Stem Auger
 DRILLING CONTRACTOR: Soil & Mat'l Testing DRILLER: Mike HELPER: Daryl
 PREPARED BY: W. Gray HAMMER WEIGHT: 140 lb HAMMER DROP: 30 in

SAMPLE NO	SAMPLE DEPTH		CORE RECVRY	BLOW COUNTS	SAMPLE/CORE DESCRIPTION
	FROM	TO			
	0	2	.5	1-6- 8-24	Sand (90%) fine, dark brown; some silt, white.
	2	4	1.0	5-18- 24- 100/3	Sand and silt (fine), dark brown.
	4	6	1.5	16-16- 16-14	Sand (90%) fine, brown and white.
	6	8	1.5	6-3- 4-3	Sand (90%) medium-coarse, brown.
	8	10	0.5	3-3- 4-5	Sand (90%) medium-coarse, brown.
	10	12	1.0	4-4- 7-8	4" sand (90%) medium-coarse, brown, moist. 4" silt and sand, (60%), dark brown.
					4" sand (90%) coarse-fine, brown.
	12	14	1.0	8-7- 9-68	Sand (90%) medium-coarse, brown, moist.
	14	16	0.3	17-11- 13-12	Sand (70%) medium-fine, brown; silt.
	16	18	1.2	11-15- 14-13	Sand (70%) fine, brown; silt.
	18	20	2.0	12-13- 12-14	Sand (70%) fine, brown; silt; small limestone fragment.

BORING/WELL: B-3 PROJECT NO: NO360SS1 PAGE: 1
 SITE General Electric Co. DRILLING 4/14/87 DRILLING
 LOCATION: Pittsfield, MA (Bldg 78) STARTED: 1110 COMPLETED: 4/21/87
 TOTAL DEPTH DRILLED: 20 ft HOLE DIAMETER: 8-3/4 in TYPE OF SAMPLE/
 CORING DEVICE: Split Spoon
 LENGTH & DIAMETER OF CORING DEVICE: 2' x 3" SAMPLING INTERVAL: 3 ft
 LAND-SURFACE ELEVATION: () SURVEYED () ESTIMATED DATUM: -
 DRILLING FLUID USED: None DRILLING METHOD: Hollow Stem Auger
 DRILLING CONTRACTOR: Soil & Mat'l Testing DRILLER: Mike HELPER: Daryl
 PREPARED BY: W. Gray HAMMER WEIGHT: 140 lb HAMMER DROP: 30 in

SAMPLE NO	SAMPLE DEPTH		CORE RECVRY	BLOW COUNTS	SAMPLE/CORE DESCRIPTION
	FROM	TO			
	0	2	2.0	14-29-35-32	Sand (70%) coarse-fine; limestone gravel; glass (fill material).
	2	4	1.5	14-11-8-11	Same as above.
	4	6	1.0	11-47-56-15	Sand and fill - glass, brick, ceramic.
	6	8	1.0	10-7-10-100/3	Same as above, with more brick.
	8	10	0.6	6-6-10-8	Same as above.
	10	12	0	7-13-12-5	NO RECOVERY.
	12	14	0	43-100/4"	Recovered 3" of wood.
	14	16	0.4	74-10-46-83	Large cement fragments; wood; brown sand, gravel.
	16	18	0.4	30-13-9-9	Cement; red brick; gravel; brown sand.
	18	20	1.0	6-3-5-3	Sand, light brown, medium-fine; small gravel.

BORING/WELL: B-4 PROJECT NO: NO360SS1 PAGE: 1
 SITE: General Electric Co. DRILLING: 1/14/87 DRILLING: 1/14/87
 LOCATION: Pittsfield, MA (Bldg 79) STARTED: 13:15 COMPLETED: 13:10
 TOTAL DEPTH DRILLED: 20 ft HOLE DIAMETER: 5-3/4 in TYPE OF SAMPLE/CORING DEVICE: Split Spoon
 LENGTH & DIAMETER OF CORING DEVICE: 2' x 2" SAMPLING INTERVAL: 1 ft
 LAND-SURFACE ELEVATION: () SURVEYED () ESTIMATED DATUM: -
 DRILLING FLUID USED: None DRILLING METHOD: Hollow Stem Auger
 DRILLING CONTRACTOR: Soil & Mat'l Testing DRILLER: Mike HELPER: Daryl
 PREPARED BY: W. Gray HAMMER WEIGHT: 140 lb HAMMER DROP: 30 in

SAMPLE NO	SAMPLE DEPTH		CORE RECVRY	BLOW COUNTS	SAMPLE/CORE DESCRIPTION
	FROM	TO			
	0	2	2.0	3-4- 7-8	Fill material - sand, gravel (mica) brick, glass, ceramic.
	2	4	-	13-9- 4-6	NO RECOVERY.
	4	6	0.6	11-7- 16-55	Fill - cement, brick, sand, wood.
	6	8	0.3	9-15- 18- 100/4	Fill sand, gravel, small cement fragments.
	8	10	0.4	8-13- 7-4	Fill sand, gravel, cement, wood.
	10	12	0.9	4-4- 4-4	Sand, gravel, cement.
	12	14	0.9	3-2- 7-9	Sand, gravel, yellow brick, orange brick, green sand, ceramic fragments.
	14	16	0.2	6-16- 17-6	Sand, gravel, yellow brick, orange brick.
	16	18	0.8	3-4- 24- 100/2	Gravel: sand, red brick, cement - WET.
	18	20	0.6	5-13- 13-6	Gravel: sand, red brick, WET.

BORING/WELL: B-5 PROJECT NO: NO360SS1 PAGE: 1
 SITE General Electric Co. DRILLING 4/14/87 DRILLING 4/14/87
 LOCATION: Pittsfield, MA (Bldg 78) STARTED: 16:00 COMPLETED: 18:35
 TOTAL DEPTH 20 ft HOLE DIAMETER: 5-3/4 in TYPE OF SAMPLE/
 DRILLED: 20 ft CORING DEVICE: Split Spoon
 LENGTH & DIAMETER OF CORING DEVICE: 2' x 2' SAMPLING INTERVAL: 1 ft
 LAND-SURFACE ELEVATION: - SURVEYED ESTIMATED DATUM: -
 DRILLING FLUID USED: None DRILLING METHOD: Hollow Stem Auger
 DRILLING CONTRACTOR: Soil & Mat'l Testing DRILLER: Mike HELPER: Daryl
 PREPARED BY: W. Gray HAMMER WEIGHT: 140 lb HAMMER DROP: 30 in

SAMPLE NO	SAMPLE DEPTH		CORE RECVRY	BLOW COUNTS	SAMPLE/CORE DESCRIPTION
	FROM	TO			
	0	2	1.2	6-26-17-13	Fill - sand, very white; gravel, plastic, paper.
	2	4	0.9	10-55-9-37	Fill - sand, brown; limestone fragments.
	4	6	0.5	5-6-9-8	Gravel, large; sand, medium, brown.
	6	8	0.7	6-7-11-7	Sand (70%) brown medium-fine; gravel.
	8	10	1.1	14-11-14-18	Sand, fine, light brown; gravel, limestone; wood.
	10	12	0.2	6-14-20-26	Sand, coarse-fine, light brown.
	12	14	2.0	7-8-11-8	Sand (95%) fine, light brown; some silt and small gravel.
	14	16	2.0	5-5-4-6	Same as above.
	16	18	2.0	5-6-4-7	Same as above, moist.
	18	20	1.5	4-7-17-42	Same as above, moist.

BORING/WELL: B-6 PROJECT NO: NO360SS1 PAGE: 1

SITE General Electric Co. DRILLING 10/15/87 DRILLING 10/15/87
 LOCATION: Pittsfield, MA (Bldg 78) STARTED: 8:43 COMPLETED: 10:55

TOTAL DEPTH DRILLED: 20 ft HOLE DIAMETER: 5-3/4 in TYPE OF SAMPLE/
 CORING DEVICE: Split Spoon

LENGTH & DIAMETER OF CORING DEVICE: 2' x 2" SAMPLING INTERVAL: 2 ft

LAND-SURFACE ELEVATION: () SURVEYED () ESTIMATED DATUM: -

DRILLING FLUID USED: None DRILLING METHOD: Hollow Stem Auger

DRILLING CONTRACTOR: Soil & Mat'l Testing DRILLER: Mike HELPER: Daryl

PREPARED BY: W. Gray HAMMER WEIGHT: 140 lb HAMMER DROP: 30 in

SAMPLE NO	SAMPLE DEPTH		CORE RECVRY	BLOW COUNTS	SAMPLE/CORE DESCRIPTION
	FROM	TO			
	0	2	1.2	4-6- 28-83	Fill - brown sand and gravel, red brick.
	2	4	1.1	22-21- 15-18	Fill - brown sand, gravel, cement, wood.
	4	6	0.4	7-11- 7-5	Fill - sand and gravel; some gray silt.
	6	8	1.0	Weight of rods	Sand (80%), gray, fine; gravel.
	8	10	1.1	3-7- 2-3	Same as above, with reeds.
	10	12	1.6	14-19- 15-10	Sand (80%), light brown, fine - gray; small gravel.
	12	14	1.1	4-11- 30-82	Sand (80%), light brown, fine; also gray fine sand; gravel.
	14	16	1.5	27-34- 35-35	Sand (80%), fine, gray; gravel, large.
	16	18	0.2	7-3- 3-3	Sand (80%) gray, fine - light brown - moist.
	18	20	1.0	5-2- 2-5	Same as above, WET.

BORING/WELL: B-7 PROJECT NO: NO360SS1 PAGE: 1
 SITE General Electric Co. DRILLING 4/15/67 DRILLING 4/15/67
 LOCATION: Pittsfield, MA (Bldg 78) STARTED: 12:20 COMPLETED: 14:05
 TOTAL DEPTH 20 ft HOLE DIAMETER: 5-3/4 in TYPE OF SAMPLE/
 CORING DEVICE: Split Spoon
 LENGTH & DIAMETER OF CORING DEVICE: 1' x 2" SAMPLING INTERVAL: 2 ft
 LAND-SURFACE ELEVATION: - SURVEYED () ESTIMATED () DATUM: -
 DRILLING FLUID USED: None DRILLING METHOD: Hollow Stem Auger
 DRILLING CONTRACTOR: Soil & Mat'l Testing DRILLER: Mike HELPER: Daryl
 PREPARED BY: W. Gray HAMMER WEIGHT: 140 lb HAMMER DROP: 30 in

SAMPLE NO	SAMPLE DEPTH		CORE RECVRY	BLOW COUNTS	SAMPLE/CORE DESCRIPTION
	FROM	TO			
	0	2	1.0	8-36-10-13	Fill - sand, brown, gravel, red brick, cement, wood.
	2	4	0.4	29-49-26-15	Fill - sand and gravel, cement.
	4	6	0.4	8-14-28-3	Fill - sand and gravel, asphalt fragments.
	6	8	0.2	4-5-10-18	Same as above.
	8	10	0.5	13-8-11-29	Same as above.
	10	12	0.2	9-13-33-70	Sand brown, coarse: gravel.
	12	14	0.5	12-10-7-7	Sand (80%) fine, light brown: gravel.
	14	16	1.3	3-8-13-37	Same as above, moist.
	16	18	1.5	8-18-11-2	Sand (80%) fine, light brown; some gravel: bottom 2" coarse dark brown sand: WET.
	18	20	0	Weight of rods	Some dark brown sand on spoon: WET.

BORING/WELL: B-9 PROJECT NO: NO360SS1 PAGE: 1
 SITE: General Electric Co. DRILLING 4/16/87 DRILLING 4/16/87
 LOCATION: Pittsfield, MA (Bldg #8) STARTED: 11:18 COMPLETED: 12:30
 TOTAL DEPTH DRILLED: 20 ft HOLE DIAMETER: 5-3/4 in TYPE OF SAMPLE/
 CORING DEVICE: Split Spoon
 LENGTH & DIAMETER OF CORING DEVICE: 3' x 2" SAMPLING INTERVAL: 2 ft
 LAND-SURFACE ELEVATION: - () SURVEYED () ESTIMATED DATUM: -
 DRILLING FLUID USED: None DRILLING METHOD: Hollow Stem Auger
 DRILLING CONTRACTOR: Soil & Mat'l Testing DRILLER: Mike HELPER: Daryl
 PREPARED BY: W. Gray HAMMER WEIGHT: 140 lb HAMMER DROP: 30 in

SAMPLE NO	SAMPLE DEPTH		CORE RECVRY	BLOW COUNTS	SAMPLE/CORE DESCRIPTION
	FROM	TO			
	0	2	1.8	12-16-	Fill, sand and gravel, brown, gray sand; red brick.
				40-97	
	2	4	0.7	48/-	Sand and gravel, fill, brown.
				100/3	
	4	6	-	100/1"	NO RECOVERY.
	6	8	0.3	16-16-	Sand and gravel fill, cement.
				8/7	
	8	10	0.4	4-4-	Same as above.
				5-8	
	10	12	0.6	8-7-	Sand and gravel fill, red brick.
				10-16	
	12	14	2.0	33-47-	Sand (80%) fine, light brown; some gravel and silt.
				39-50	
	14	16	2.0	18-42-	Sand (80%) same as above, light brown - gray.
				50-42	
	16	18	1.8	13-13-	Same as above; then coarse sand, darker.
				13-9	
	18	20	0.7	10-9-	Sand (80%), fine; light brown-gray; gravel, some
				7-7	silt.

SAMPLE CORE LOG

BORING/WELL: B-10 PROJECT NO: NO360SS1 PAGE: 1
 SITE General Electric Co. DRILLING 4/16/87 DRILLING 4/16/87
 LOCATION: Pittsfield, MA Bldg 78A STARTED: 14:03 COMPLETED: 15:13
 TOTAL DEPTH DRILLED: 20 ft HOLE DIAMETER: 5-3/4 in TYPE OF SAMPLE/
 CORING DEVICE: Split Spoon
 LENGTH & DIAMETER OF CORING DEVICE: 1' x 2" SAMPLING INTERVAL: 0 ft
 LAND-SURFACE ELEVATION: - SURVEYED ESTIMATED DATUM: -
 DRILLING FLUID USED: None DRILLING METHOD: Hollow Stem Auger
 DRILLING CONTRACTOR: Soil & Mat'l Testing DRILLER: Mike HELPER: Daryl
 PREPARED BY: W. Gray HAMMER WEIGHT: 140 lb HAMMER DROP: 30 in

SAMPLE NO	SAMPLE DEPTH		CORE RECVY	BLOW COUNTS	SAMPLE/CORE DESCRIPTION
	FROM	TO			
	0	2	1.6	3-8- 16-23	Top soil; sand and gravel limestone; fine light brown sand.
	2	4	1.0	17-14- 11-12	Sand (80%) fine, light brown; some silt and gravel.
	4	6	-	4-4- 3-3	NO RECOVERY.
	6	8	0.8	11-7- 3-4	Same as 2-4' spoon.
	8	10	0.3	1-2- 2-3	Same as above.
	10	12	0.6	8-3- 3-3	Sand (80%) fine-coarse, light brown; some silt and gravel.
	12	14	0.7	3-2- 3-5	Same as above; large fragments of limestone.
	14	16	0.6	2-3- 3-3	Same as above.
	16	18	0.4	1-4- 5-5	Same as above; but no limestone; moist.
	18	20	1.0	3-7- 6-4	6" same as above; 6" black sandy top soil, some gravel, small roots; moist.

BORING/WELL: B-11 PROJECT NO: NO360SS1 PAGE: 1
 SITE: General Electric Co. DRILLING: 4/16/87 DRILLING: 4/16/87
 LOCATION: Pittsfield, MA (Bldg 78) STARTED: 16:25 COMPLETED: 17:45
 TOTAL DEPTH DRILLED: 30 ft HOLE DIAMETER: 5-3/4 in TYPE OF SAMPLE/
 CORING DEVICE: Split Spoon
 LENGTH & DIAMETER OF CORING DEVICE: 2' x 2" SAMPLING INTERVAL: 0 ft
 LAND-SURFACE ELEVATION: _____ SURVEYED _____ ESTIMATED DATUM: _____
 DRILLING FLUID USED: None DRILLING METHOD: Hollow Stem Auger
 DRILLING CONTRACTOR: Soil & Mat'l Testing DRILLER: Mika HELPER: Daryl
 PREPARED BY: W. Gray HAMMER WEIGHT: 140 lb HAMMER DROP: 30 in

SAMPLE NO	SAMPLE DEPTH		CORE RECVRY	BLOW COUNTS	SAMPLE/CORE DESCRIPTION
	FROM	TO			
	0	2	1.7	1-3- 9-23	3" top soil; sand (80%) fine, light brown some silt and gravel.
	2	4	1.5	35-29- 36-62	Same as above with coarse-fine sand; some limestone gravel.
	4	6	1.0	19-20- 23-14	Same as above.
	6	8	1.0	9-6- 8-7	Same as above.
	8	10	0.8	2-3- 3-3	Same as above.
	10	12	0.5	5-7- 6-5	Same as above.
	12	14	1.0	2-1- 3-3	Top 6" same as above; lower 6" sand (80%) fine; some silt and gravel.
	14	16	-	8-9- 11-15	NO RECOVERY.
	16	18	1.7	5-2- 2-3	Top 3" same as 12-14' spoon; moist then black organic type layer - small roots, sandy.
	18	20	1.0	3-13- 17-20	Top 6" coarse, light brown sand; bottom 6" sand, medium-fine, light brown-gray, moist.

SPRING/WELL: B-12 PROJECT NO: NO360SS1 PAGE: 1
 SITE: General Electric Co. DRILLING: 1/17/87 DRILLING: 1/17/87
 LOCATION: Pittsfield, MA (Bldg 78) STARTED: 9:35 COMPLETED: 11:40
 TOTAL DEPTH DRILLED: 20 ft HOLE DIAMETER: 5-3/4 in TYPE OF SAMPLE/ CORING DEVICE: Split Spoon
 LENGTH & DIAMETER OF CORING DEVICE: 2' x 3" SAMPLING INTERVAL: 3 ft
 LAND-SURFACE ELEVATION: - SURVEYED: - ESTIMATED: - DATUM: -
 DRILLING FLUID USED: None DRILLING METHOD: Hollow Stem Auger
 DRILLING CONTRACTOR: Soil & Mat'l Testing DRILLER: Mike HELPER: Daryl
 PREPARED BY: W. Gray HAMMER WEIGHT: 140 lb HAMMER DROP: 30 in

SAMPLE NO	SAMPLE DEPTH		CORE RECVRY	BLOW COUNTS	SAMPLE/CORE DESCRIPTION
	FROM	TO			
	0	2	1.7	17-7-53-71	Sand and gravel fill; medium-coarse; some white sand.
	2	4	2.0	41-18-15-10	Sand and gravel as above; bottom 6" finer gray sand with gravel.
	4	6	1.6	10-11-19-18	Sand and gravel; coarse-fine brown and gray.
	6	8	0.5	10-13-10-7	Same as above
	8	10	1.0	3-4-3-4	Same as above; bottom 2" darker sandy material with grass and small roots.
	10	12	0.5	2-13-18-12	Top 1-1/2" brown sand with small gravel 1/2" fine gray sand 1/2" fine light brown sand 1/2" brown sand with small gravel 2" fine gray sand with larger gravel and wood 1" dark black fine sand, silt and some clay; wood.
	12	14	1.0	24-7-17-16	6" charred wood and red brick; large fragments. 6" bright yellow crushed stone.
	14	15	1.0	32-3-5-4	6" crushed yellow with metal fragments as above; large metal fragments in cuttings, 6" fine sand light brown - gray.
	16	18	1.0	5-7-7-6	Top 2" sand coarse-fine; 8" fine light brown sand.

BORING/WELL: B-13 PROJECT NO: NO360SS1 PAGE: 1
 SITE General Electric Co. DRILLING 1/17/67 DRILLING 1/20/67
 LOCATION: Pittsfield, MA (Bldg 78) STARTED: 12:35 COMPLETED: 10:50
 TOTAL DEPTH DRILLED: 20 ft HOLE DIAMETER: 5-3/4 in TYPE OF SAMPLE/
 CORING DEVICE: Split Spoon
 LENGTH & DIAMETER OF CORING DEVICE: 2' x 2" SAMPLING INTERVAL: 2 ft
 LAND-SURFACE ELEVATION: SURVEYED ESTIMATED DATUM:
 DRILLING FLUID USED: None DRILLING METHOD: Hollow Stem Auger
 DRILLING CONTRACTOR: Soil & Mat'l Testing DRILLER: Mike HELPER: Daryl
 PREPARED BY: W. Gray HAMMER WEIGHT: 140 lb HAMMER DROP: 30 in

SAMPLE NO	SAMPLE DEPTH		CORE RECVRY	BLOW COUNTS	SAMPLE/CORE DESCRIPTION
	FROM	TO			
	0	2	1.3	10-20-	Fill; sand and gravel.
				30-28	
	2	4	1.0	38-41-	do
				36-21	
	4	6	0.2	10-8-	do; with large limestone fragments.
				11-10	
	6	8	0.5	4-6-	do
				6-12	
	8	10	0.4	36-32-	do; with more gravel.
				48-11	
	10	12	0	100/11	NO RECOVERY.
	12	14	2.0	26-22-	Sand, medium-fine, light brown; some gravel.
				48-25	
	14	16	0.4	7-6-	do
				4-3	
	16	18	1.0	1-0-	do; moist.
				2-1	
	18	20	0.5	1-1-	do; wet.
				2-1	

SAMPLE CORE LOG

BORING/WELL: B-14 PROJECT NO: NO360SS1 PAGE: 1
 SITE General Electric Co. DRILLING 1/20/87 DRILLING 1/20/87
 LOCATION: Pittsfield, MA (Bldg 79) STARTED: 11:30 COMPLETED: 13:20
 TOTAL DEPTH 20 ft HOLE DIAMETER: 5-3/4 in TYPE OF SAMPLE/
 DRILLED: 20 ft CORING DEVICE: Split Spoon
 LENGTH & DIAMETER OF CORING DEVICE: 2' x 2" SAMPLING INTERVAL: 3 ft
 LAND-SURFACE ELEVATION: - () SURVEYED () ESTIMATED DATUM: -
 DRILLING FLUID USED: None DRILLING METHOD: Hollow Stem Auger
 DRILLING CONTRACTOR: Soil & Mat'l Testing DRILLER: Mike HELPER: Daryl
 PREPARED BY: W. Gray HAMMER WEIGHT: 140 lb HAMMER DROP: 30 in

SAMPLE NO	SAMPLE DEPTH		CORE RECVRY	BLOW COUNTS	SAMPLE/CORE DESCRIPTION
	FROM	TO			
	0	2	0.6	4-6-	Fill: sand, gravel, glass, wood.
				6-16	
	2	4	0	100/.2	NO RECOVERY.
	4	6	0.4	3-3-	Sand, gray; gravel, large-small: some silt, wood.
				3-4	glass.
	6	8	1.2	18-14-	Sand, medium-fine, light brown: gravel, medium
				25-23	2" fine black sand
					6" coarse-fine, brown sand with gravel.
	8	10	1.0	22-16-	Sand, coarse-fine, brown with gravel
				15-15	3" sand, medium-fine, light brown-gray: small gravel.
	10	12	1.2	8-13-	Sand, medium-fine, light brown-gray: large gravel.
				12-11	
	12	14	1.0	14-10-	do
				6-7	
	14	16	1.0	3-3-	do
				3-4	
	16	18	0.9	3-2-	do
				2-4	
	18	20	1.1	3-3-	Sand, medium-fine, light brown-gray; some silt; small
				3-3	gravel.

BORING/WELL: B-15 PROJECT NO: NOB60SS1 PAGE: 1
 SITE: General Electric Co. DRILLING: 4/20/87 BRILLING: 4/20/87
 LOCATION: Pittsfield, MA (Bldg 78) STARTED: 14:05 COMPLETED: 16:10
 TOTAL DEPTH DRILLED: 20 ft HOLE DIAMETER: 3-3/4 in TYPE OF SAMPLE/CORING DEVICE: Split Spoon
 LENGTH & DIAMETER OF CORING DEVICE: 3' x 2" SAMPLING INTERVAL: 10 ft
 LAND-SURFACE ELEVATION: SURVEYED ESTIMATED DATUM:
 DRILLING FLUID USED: None DRILLING METHOD: Hollow Stem Auger
 DRILLING CONTRACTOR: Soil & Mat'l Testing DRILLER: Mike HELPER: Daryl
 PREPARED BY: W. Gray HAMMER WEIGHT: 140 lb HAMMER DROP: 30 in

SAMPLE NO	SAMPLE DEPTH		CORE RECVRY	BLOW COUNTS	SAMPLE/CORE DESCRIPTION
	FROM	TO			
	0	2	1.0	8-12- 16-22	Fill; sand, gravel, red brick, limestone.
	2	4	0.8	21-19- 40- 100/.2	do
	4	6	1.3	11-12- 30-49	Fill; limestone fragments, sand, gravel, glass, red brick.
	6	8	1.4	34-22- 15-15	do; some wood
	8	10	1.0	8-6- 5-7	do
	10	12	0.9	8-5- 5-28	Sand, coarse-fine, brown; some gravel.
	12	14	1.7	6-11- 17-20	Sand, medium-fine, light brown; some gravel and glass.
	14	16	1.1	6-7- 5-4	Sand, fine, light brown; some silt and small gravel.
	16	18	1.6	4-6- 26-38	do
	18	20	1.0	11-16- 12-12	do

SAMPLE CORE LOG

BORING/WELL: B-16 PROJECT NO: NO360SS1 PAGE: 1
 SITE General Electric Co. DRILLING 4/20/87 DRILLING 4/20/87
 LOCATION: Pittsfield, MA (Bldg 78) STARTED: 16:45 COMPLETED: 18:20
 TOTAL DEPTH 20 ft HOLE DIAMETER: 6-3/4 in TYPE OF SAMPLE/
 CORING DEVICE: Split Spoon
 LENGTH & DIAMETER OF CORING DEVICE: 2' x 2" SAMPLING INTERVAL: 2 ft
 LAND-SURFACE ELEVATION: - () SURVEYED ESTIMATED DATUM: -
 DRILLING FLUID USED: None DRILLING METHOD: Hollow Stem Auger
 DRILLING CONTRACTOR: Soil & Mat'l Testing DRILLER: Mike HELPER: Daryl
 PREPARED BY: W. Gray HAMMER WEIGHT: 140 lb HAMMER DROP: 20 in

SAMPLE NO	SAMPLE DEPTH		CORE RECOVERY	BLOW COUNTS	SAMPLE/CORE DESCRIPTION
	FROM	TO			
	0	2	0.9	5-8- 8-14	1" top soil; sand, coarse-medium; gravel; glass fragments.
	2	4	0.5	5-10- 9-6	Red brick, yellow brick; sand, coarse, brown.
	4	6	0.5	7-28- 13-4	Sand, coarse, brown; some red brick.
	6	8	0.4	6-4- 8-7	do
	8	10	0.5	5-4- 6-5	Sand, medium-fine, brown; some silt; red brick; cinders.
	10	12	1.0	1-3- 2-2	Sand, coarse, reddish brown; gravel, medium.
	12	14	0	2-3- 3-3	No recovery.
	14	16	0.7	1-1- 1-6	Sand, coarse-fine, light brown; wet.
	16	18	1.8	1-8- 12-10	do
	18	20	1.8	13-16- 15-18	Sand, coarse.

ALTRESCO AREA

SAMPLE CORE LOG

BORING WELL: 71-1 PROJECT NO: NC260352 PAGE: 1 of 1
 SITE General Electric Co. DRILLING DRILLING
 LOCATION: Pittsfield, MA (Bldg 73) STARTED: 5/23/87 COMPLETED: 6/23/87
 TOTAL DEPTH 20 ft HOLE DIAMETER: 3-3/4 in TYPE OF SAMPLE/
 DRILLED: 20 ft DIAMETER: 3-3/4 in BORING DEVICE: split spoon
 LENGTH & DIAMETER SAMPLING
 OF CORING DEVICE: 2" x 2" INTERVAL: 3 ft
 LAND-SURFACE SURVEYED
 ELEVATION: ESTIMATED DATUM:
 DRILLING FLUID USED: none DRILLING METHOD: auger
 DRILLING CONTRACTOR: Soil & Mat'l Testing DRILLER: Mike HELPER: Mike
 PREPARED BY: W. Gray HAMMER WEIGHT: 1-0 lb HAMMER DROP: 30 in

SAMPLE NO	SAMPLE DEPTH		CORE RECOVERY	BLOW COUNTS	SAMPLE/CORE DESCRIPTION
	FROM	TO			
	0	2	1.0	5-8-10-13	Fill - Sandy top soil, brown (6 inches) Black silt, wood fragments (6 inches).
2	4		-	100/2"	No recovery, wood in bottom of split spoon sampler.
4	6		1.5	4-8-24-17	Fill - Silt (80%) with fine sand, little clay, gray, black; oil sheen on sediments.
6	8		0.5	12-13-11-16	Fill - Silt (80%), with fine sand, little clay, gray, oil sheen on sediments.
8	10		1.5	10-21-17-8	Same as above.
10	12		1.3	2-2-1-2	Fill - Silt (60%), with fine sand, little clay, gray, some gravel, grass; oil sheen on sediments
12	14		0.4	0-3-3-12	Sand (50%) fine to medium, some silt, gray; oil sheen on sediments
14	16		2.0	3-4-8-7	Sand (80%), little silt, gray; oil sheen on sediments.
					Silt (80%), with fine sand, little clay, gray, oil sheen on sediments.
16	18		1.0	3-6-18-18	Same sequence as above (sand over silt), oil sheen on sediments.
18	20		1.0	9-7-6-7	Silt (80%) with fine sand, little clay, gray, little gravel; oil sheen on sediments.
					Perched water at 3.5 feet

SAMPLE CORE LOG

BORING/WELL: 02-2 PROJECT NO: NO360SS2 PAGE: 1 of 1
 SITE General Electric Co. DRILLING DRILLING
 LOCATION: Fittsfield, MA (Bldg 72) STARTED: 6/23/87 COMPLETED: 6/23/87
 TOTAL DEPTH 20 ft HOLE DIAMETER: 5-3/4 in TYPE OF SAMPLE/
 DRILLED: 20 ft CORING DEVICE: split spoon
 LENGTH & DIAMETER OF CORING DEVICE: 2" x 2" SAMPLING INTERVAL: 2 ft
 LAND-SURFACE ELEVATION: SURVEYED ESTIMATED DATUM:
 DRILLING FLUID USED: none DRILLING METHOD: auger
 DRILLING CONTRACTOR: Soil & Mat'l Testing DRILLER: Mike HELPER: Mike
 PREPARED BY: W. Gray HAMMER WEIGHT: 140 lb HAMMER DROP: 30 in

SAMPLE NO	SAMPLE DEPTH		CORE RECVRY	BLOW COUNTS	SAMPLE/CORE DESCRIPTION
	FROM	TO			
	0	2	-	6-6-	No recovery.
				16-26	
	2	4	1.5	9-12-	Fill - Silt (80%), with fine sand, brown, little
				9-15	clay, little gravel.
	4	6	1.5	8-8-	Same as above.
				7-7	
	6	8	1.5	4-5-	Same as above.
				3-3	
	8	10	1.0	3-3-	Same as above.
				4-5	
	10	12	0.3	3-3-	Same as above, moist.
				2-2	
	12	14	0.9	2-3-	Fill - Silt (80%), with fine sand, brown, gray and
				3-8	black, metal fragments, little gravel.
	14	16	2.0	10-12-	Silt (80%), with fine sand, gray, little gravel,
				12-11	little clay, moist.
	16	18	1.5	6-6-	Same as above, but a higher percentage of gravel.
				5-4	
	18	20	1.0	3-10-	Same as above.
				18-83	

SAMPLE CORE LOG

BORING/WELL: 72-3 PROJECT NO: NO360SS2 PAGE: 1 of 1
 SITE General Electric Co. DRILLING DRILLING
 LOCATION: Pittsfield, MA (Bldg 72) STARTED: 6/23/87 COMPLETED: 6/23/87
 TOTAL DEPTH 20 ft HOLE DIAMETER: 5-3/4 in TYPE OF SAMPLE/
 DRILLED: 20 ft CORING DEVICE: split spoon
 LENGTH & DIAMETER 3' x 2" SAMPLING INTERVAL: 2 ft
 OF CORING DEVICE: 3' x 2" INTERVAL: 2 ft
 LAND-SURFACE () SURVEYED
 ELEVATION: () ESTIMATED DATUM:
 DRILLING FLUID USED: none DRILLING METHOD: auger
 DRILLING CONTRACTOR: Soil & Mat'l Testing DRILLER: Mike HELPER: Mike
 PREPARED BY: W. Gray HAMMER WEIGHT: 140 lb HAMMER DROP: 30 in

SAMPLE NO	SAMPLE DEPTH		CORE RECVRY	BLOW COUNTS	SAMPLE/CORE DESCRIPTION
	FROM	TO			
	0	2	1.0	3-5-	Silt (80%) with fine sand, black, gray and brown.
				10-12	little gravel.
	2	4	1.0	10-14-	Same as above but all brown.
				10-17	
	4	6	1.0	10-12	Sand (70%), fine to medium, with silt, brown.
				9-10	
	6	8	0.5	5-4-	Silt (80%) with fine sand, brown, little gravel.
				3-4	
	8	10	1.5	4-3-	Sand, fine (80%) with silt, light brown, white.
				2-2	layered, moist.
	10	12	1.5	2-2	Same as above (6 inches).
				1-6	Sand, fine to medium (70%), with silt, black.
	12	14	1.0	4-4-	Sand (80%), some silt, brown, wet (6 inches).
				5-10	Silt (80%), with fine sand, brown, little clay (6 inches).
	14	16	1.0	7-9-	Silt (80%), gray, some clay, little gravel.
				8-10	
	16	18	1.6	4-8-	Same as above.
				20-21	
	18	20	1.0	14-17-	Sand (70%), some silt, brown, little gravel.
				18-20	
					Water at 16.3 feet

SAMPLE/CORE LOG

SORING/WELL: 02-4 PROJECT NO: NO360SS2 PAGE: 1 of 1
 SITE General Electric Co. DRILLING DRILLING
 LOCATION: Pittsfield, MA (Bldg 72) STARTED: 6/24/87 COMPLETED: 6/24/87
 TOTAL DEPTH 20 ft HOLE DIAMETER: 5-3/4 in TYPE OF SAMPLE/
 DRILLED: 20 ft CORING DEVICE: split spoon
 LENGTH & DIAMETER 2' x 2" SAMPLING INTERVAL: 2 ft
 OF CORING DEVICE: 2' x 2" INTERVAL: 2 ft
 LAND-SURFACE () SURVEYED
 ELEVATION: () ESTIMATED DATUM:
 DRILLING FLUID USED: none DRILLING METHOD: auger
 DRILLING CONTRACTOR: Soil & Mat'l Testing DRILLER: Mike HELPER: Mike
 PREPARED BY: W. Gray HAMMER WEIGHT: 140 lb HAMMER DROP: 30 in

SAMPLE NO	SAMPLE DEPTH		CORE RECVRY	BLOW COUNTS	SAMPLE/CORE DESCRIPTION
	FROM	TO			
	0	2	1.5	2-2-	Fill - Sandy, brown, top soil; some gravel (6 inches)
				4-3	Fill - Silt (85%), with fine sand, black.
	2	4	0.3	3-2-	Same as above.
				2-2	
	4	6	2.0	1-0-	Same as above.
				1-3	
	6	8	1.5	9-16-	Fill - silt (80%), with fine sand, little clay,
				15-12	little gravel, light brown, moist.
	8	10	1.5	5-4-	Same as above, wet.
				4-3	
	10	12	0.5	0-10-	Fill - Sand, fine to medium (70%), with silt, light
				4-2	brown-gray (4 inches).
					Top Soil, dark brown, roots (2 inches).
	12	14	1.3	1-10	Sand (70%) medium-fine, with silt, brown-gray, little
				12-12	gravel; oil sheen on sediments.
	14	16	1.0	7-9-	Same as above.
				5-12	
	16	18	0.8	10-6-	Same as above.
				6-6	
	18	20	1.7	2-5-	Same as above.
				5-21	
					Water at 17.3 feet

SAMPLE/CORE LOG

BORING/WELL: 70-5 PROJECT NO: N0360SS2 PAGE: 1 of 1
 SITE General Electric Co. DRILLING DRILLING
 LOCATION: Pittsfield, MA (Bldg 70) STARTED: 6/24/87 COMPLETED: 6/24/87
 TOTAL DEPTH 20 ft HOLE DIAMETER: 5-3/4 in TYPE OF SAMPLE/
 DRILLED: 20 ft CORING DEVICE: split spoon
 LENGTH & DIAMETER OF CORING DEVICE: 2' x 2" SAMPLING INTERVAL: 2 ft
 LAND-SURFACE ELEVATION: () SURVEYED
() ESTIMATED DATUM: _____
 DRILLING FLUID USED: none DRILLING METHOD: auger
 DRILLING CONTRACTOR: Soil & Mat'l Testing DRILLER: Mike HELPER: Mike
 PREPARED BY: W. Gray HAMMER WEIGHT: 140 lb HAMMER DROP: 30 in

SAMPLE NO	SAMPLE DEPTH		CORE RECVRY	BLOW COUNTS	SAMPLE/CORE DESCRIPTION
	FROM	TO			
	0	2	2.0	3-22-	Sandy, top soil (6 inches).
				22-24	Sand, fine to medium (80%), brown; some gravel.
	2	4	1.0	13-20-	Same as above.
				17-34	
	4	6	0.7	13-20-	Same as above.
				25-24	
	6	8	1.0	7-6-	Same as above.
				5-3	
	8	10	-	2-2-	No recovery.
				2-2	
	10	12	1.0	2-2-	Sand (70%), some silt, brown, little gravel.
				3-2	
	12	14	1.0	3-4-	Sand (80%), some silt, brown.
				5-21	
	14	16	1.0	10-6-	Silt (80%), with fine sand, brown; little clay,
				8-8	little gravel.
	16	18	1.5	7-7-	Same as above, moist.
				8-15	
	18	20	1.7	7-11-	Silt (75%), some clay, brown, little gravel, moist.
				17-18	

SAMPLE CORE LOG

BORING/WELL: TC-6 PROJECT NO: NO360SS2 PAGE: 1 of 1
 SITE General Electric Co. DRILLING DRILLING
 LOCATION: Pittsfield, MA (Bldg 7C) STARTED: 6/25/87 COMPLETED: 6/25/87
 TOTAL DEPTH 30 ft HOLE DIAMETER: 5-3/4 in TYPE OF SAMPLE/
 DRILLED: 30 ft CORING DEVICE: split spoon
 LENGTH & DIAMETER 2" x 2" SAMPLING INTERVAL: 2 ft
 OF CORING DEVICE: 2" x 2" SURVEYED ELEVATION:
 ELEVATION: ESTIMATED DATUM:
 DRILLING FLUID USED: none DRILLING METHOD: auger
 DRILLING CONTRACTOR: Soil & Mat'l Testing DRILLER: Mike HELPER: Mike
 PREPARED BY: W. Gray HAMMER WEIGHT: 140 lb HAMMER DROP: 30 in

SAMPLE NO	SAMPLE DEPTH		CORE RECVRY	BLOW COUNTS	SAMPLE/CORE DESCRIPTION
	FROM	TO			
	0	2	1.0	3-26-	Top soil, brown (4 inches).
				20-20	Silt with fine sand; brown (4 inches).
					Fragments of limestone (4 inches).
	2	4	1.0	5-7-	Sand, fine (70%), with silt, brown.
				12-34	
	4	6	2.0	30-36-	Sand (75%), some silt, some gravel, brown.
				27-26	
	6	8	1.0	5-7-	Silt (80%), with fine sand, gray (8 inches).
				5-4	Sand (70%), some silt, little gravel, brown (4 inches).
	8	10	0.9	3-3-	Sand (70%), some silt, some gravel, brown.
				5-5	
	10	12	0.6	4-5-	Same as above.
				7-6	
	12	14	1.5	3-4-	Sand (75%), some silt, brown.
				4-5	
	14	16	1.5	4-5-	Same as above.
				6-9	
	16	18	2.0	5-8-	Same as above.
				7-16	
	18	20	1.5	5-9-	Silt (80%), some fine sand, little clay, little gravel, brown, moist.
				12-18	

SAMPLE CORE LOG

BORING/WELL: 72-7 PROJECT NO: NO360SS2 PAGE: 1 of 1

SITE General Electric Co. DRILLING DRILLING
 LOCATION: Pittsfield, MA (Bldg 72) STARTED: 6/24/87 COMPLETED: 6/25/87

TOTAL DEPTH 20 ft HOLE DIAMETER: 5-3/4 in TYPE OF SAMPLE/
 DRILLED: 20 ft CORING DEVICE: split spoon

LENGTH & DIAMETER 2' x 2" SAMPLING INTERVAL: 2 ft
 OF CORING DEVICE: 2' x 2"

LAND-SURFACE () SURVEYED
 ELEVATION: () ESTIMATED DATUM:

DRILLING FLUID USED: none DRILLING METHOD: auger

DRILLING CONTRACTOR: Soil & Mat'l Testing DRILLER: Mike HELPER: Mike

PREPARED BY: W. Gray HAMMER WEIGHT: 140 lb HAMMER DROP: 30 in

SAMPLE NO	SAMPLE DEPTH		CORE RECVRY	BLOW COUNTS	SAMPLE/CORE DESCRIPTION
	FROM	TO			
	0	2	1.5	4-4-	Top soil (4 inches); Sand, medium-fine (75%). some
				8-9	silt, little gravel.
	2	4	2.0	3-2-	Same as above.
				5-12	
	4	6	2.0	5-5-	Same as above.
				3-3	
	6	8	1.5	2-3-	Sand (75%), some silt, brown.
				4-4	
	8	10	1.2	3-3-	Sand (60%), fine with silt, little clay, brown.
				1-2	little gravel, moist
	10	12	1.0	2-3-	Same as above.
				3-11	
	12	14	0.3	12-6-	Same as above, with limestone fragment.
				8-5	
	14	16	0.8	12-7-	Silt (75%), some fine sand, some clay, brown:
				4-6	little gravel.
	16	18	0.2	1-3-	Same as above.
				4-7	
	18	20	-	7-6-	No recovery.
				3-5	

SAMPLE CORE LOG

BORING/WELL: 72-8 PROJECT NO: NO360562 PAGE: 1 of 1
 SITE General Electric Co. DRILLING DRILLING
 LOCATION: Pittsfield, MA (Bldg 72) STARTED: 6/25/87 COMPLETED: 6/25/87
 TOTAL DEPTH DRILLED: 20 ft HOLE DIAMETER: 5-3/4 in TYPE OF SAMPLE/
 CORING DEVICE: split spoon
 LENGTH & DIAMETER OF CORING DEVICE: 2' x 2" SAMPLING INTERVAL: 1 ft
 LAND-SURFACE ELEVATION: () SURVEYED
() ESTIMATED DATUM: _____
 DRILLING FLUID USED: none DRILLING METHOD: auger
 DRILLING CONTRACTOR: Soil & Mat'l Testing DRILLER: Mike HELPER: Mike
 PREPARED BY: W. Gray HAMMER WEIGHT: 140 lb HAMMER DROP: 30 in

SAMPLE NO	SAMPLE DEPTH		CORE RECVRY	BLOW COUNTS	SAMPLE/CORE DESCRIPTION
	FROM	TO			
	0	2	1.0	3-8- 100/2	3" Top soil: Sand (80%) medium-fine, some silt, some gravel.
	2	4	0.6	18-24- 14-13	Same as above.
	4	6	1.5	18-24- 22-32	Silt (80%), with fine sand, brown, some limestone fragments.
	6	8	1.5	13-7- 12-6	Sand (70%) fine; some silt, brown
	8	10	1.0	4-5- 4-5	Sand (80%), some silt, brown.
	10	12	1.5	2-2- 5-5	Same as above.
	12	14	1.0	3-4- 4-3	Sand, fine (70%), some silt, little clay; little gravel, brown, moist.
	14	16	1.0	2-3- 6-10	Same as above, with limestone fragments.
	16	18	1.3	6-8- 6-6	Silt (75%), with fine sand, little clay, some gravel.
	18	20	1.3	4-6- 8-5	Same as above.

SAMPLE/CORE LOG

BORING/WELL: 12-9 PROJECT NO: NO360SS2 PAGE: 1 of 1
 SITE General Electric Co. DRILLING DRILLING
 LOCATION: Pittsfield, MA (Bldg 12) STARTED: 6/26/87 COMPLETED: 6/26/87
 TOTAL DEPTH 20 ft HOLE DIAMETER: 5-3/4 in TYPE OF SAMPLE/
 DRILLED: 20 ft CORING DEVICE: split spoon
 LENGTH & DIAMETER 2' x 2" SAMPLING INTERVAL: 2 ft
 OF CORING DEVICE: 2' x 2" INTERVAL: 2 ft
 LAND-SURFACE () SURVEYED
 ELEVATION: () ESTIMATED DATUM:
 DRILLING FLUID USED: none DRILLING METHOD: auger
 DRILLING CONTRACTOR: Soil & Mat'l Testing DRILLER: Mike HELPER: Mike
 PREPARED BY: W. Gray HAMMER WEIGHT: 140 lb HAMMER DROP: 30 in

SAMPLE NO	SAMPLE DEPTH		CORE RECVRY	BLOW COUNTS	SAMPLE/CORE DESCRIPTION
	FROM	TO			
	0	2	1.5	4-8-	Top soil, sandy, brown (3 inches).
				12-11	Sand, fine to medium (50%), with silt, brown; some gravel.
	2	4	1.8	9-12-	Same as above.
				21-62	
	4	6	2.0	10-14	Sand, fine (50%), with silt, gray; some gravel.
				15-14	
	6	8	1.0	10-6-	Same as above.
				4-4	
	8	10	1.5	0-2-	Same as above (3 inches)
				3-6	Clay, gray (2 inches)
					Sand (70%), some silt; brown; roots.
	10	12	1.0	7-6-	Same as above (6 inches).
				4-6	Sand, medium-fine (50%) with silt, gray; some gravel; some clay.
	12	14	0.8	2-1-	Same as above; moist.
				4-5	
	14	16	1.0	4-5-	Silt, (70%), with fine sand; some clay, gray-brown;
				5-4	some gravel, moist.
	16	18	1.3	1-36-	Same as above; wet.
				7-9	
	18	20	1.3	5-7-	Same as above.
				5-3	
					Water at 19.8 feet

SAMPLE CORE LOG

BORING/WELL: 72-11 PROJECT NO: NO360SS2 PAGE: 1 of 1
 SITE General Electric Co. DRILLING DRILLING
 LOCATION: Pittsfield, MA (Bldg 72) STARTED: 6/26/87 COMPLETED: 6/26/97
 TOTAL DEPTH 30 ft HOLE DIAMETER: 5-3/4 in TYPE OF SAMPLE/
 DRILLED: 30 ft CORING DEVICE: split spoon
 LENGTH & DIAMETER OF CORING DEVICE: 2' x 2" SAMPLING INTERVAL: 2 ft
 LAND-SURFACE ELEVATION: () SURVEYED
() ESTIMATED DATUM: _____
 DRILLING FLUID USED: none DRILLING METHOD: auger
 DRILLING CONTRACTOR: Soil & Mat'l Testing DRILLER: Mike HELPER: Mike
 PREPARED BY: W. Gray HAMMER WEIGHT: 140 lb HAMMER DROP: 20 in

SAMPLE NO	SAMPLE DEPTH		CORE RECVRY	BLOW COUNTS	SAMPLE/CORE DESCRIPTION
	FROM	TO			
	0	2	1.2	2-12	Top soil, sandy, brown; some gravel (4 inches).
				8-8	Sand (60%), some silt, brown; some gravel.
	2	4	0.6	8-12	Sand, fine to medium (50%) with silt; some gravel.
				12-12	
	4	6	1.0	12-6-	Silt (65%) with fine sand, gray; some gravel.
				7-8	
	6	8	1.7	3-4-	Sand (80%), some silt, brown.
				3-3	
	8	10	1.0	4-4-	Same as above, with some gravel.
				4-4	
	10	12	1.4	3-3-	Same as above.
				4-4	
	12	14	1.8	3-4-	Same as above.
				4-6	
	14	16	1.5	3-3-	Same as above; some red staining on sediments; wet.
				3-2	
	16	18	-	2-2-	No recovery.
				6-4	
	18	20	1.0	4-5-	Silt (80%); some clay, gray; some gravel.
				5-4	
					Water at 15 feet

SAMPLE CORE LOG

BORING/WELL: 70-10 PROJECT NO: 00360SS2 PAGE: 1 of 1
 SITE General Electric Co. DRILLING DRILLING
 LOCATION: Pittsfield, MA (Bldg 70) STARTED: 6/26/87 COMPLETED: 6/26/87
 TOTAL DEPTH 20 ft HOLE DIAMETER: 5-3/4 in TYPE OF SAMPLE/
 DRILLED: 20 ft CORING DEVICE: split spoon
 LENGTH & DIAMETER OF CORING DEVICE: 2' x 2" SAMPLING INTERVAL: 2 ft
 LAND-SURFACE ELEVATION: SURVEYED
 ESTIMATED DATUM:
 DRILLING FLUID USED: none DRILLING METHOD: auger
 DRILLING CONTRACTOR: Soil & Mat'l Testing DRILLER: Mike HELPER: Mike
 PREPARED BY: W. Gray HAMMER WEIGHT: 140 lb HAMMER DROP: 30 in

SAMPLE NO	SAMPLE DEPTH		CORE RECVRY	BLOW COUNTS	SAMPLE/CORE DESCRIPTION
	FROM	TO			
	0	2	1.5	6-11-	Top soil, sandy (4 inches); Sand, fine to medium
				11-15	(60%), some silt, some gravel, brown.
	2	4	2.0	12-19-	Same as above.
				30-64	
	4	6	1.0	10-20	Same as above; some limestone fragments.
				21-25	
	6	8	1.3	9-12-	Sand (70%) with silt, some gravel, brown.
				13-12	
	8	10	1.0	6-5-	Same as a bove.
				4-5	
	10	12	1.5	4-5-	Sand (80%), some silt, brown; little gravel.
				4-4	
	12	14	2.0	3-3-	Sand (85%), little silt, brown.
				3-5	
	14	16	1.8	4-4-	Same as above (3 inches).
				3-4	Sand, black, coarse-medium (2 inches).
					Sand (85%), some silt, little clay, brown.
	16	18	0.5	4-6-	Silt (80%), some clay, gray; some limestone
				5-3	fragments.
	18	20	0.9	2-5-	Silt (80%), some clay, gray; some gravel.
				7-12	

SAMPLE CORE LOG

BORING/WELL: 72-12 PROJECT NO: NO360SS2 PAGE: 1 of 1
 SITE General Electric Co. DRILLING DRILLING
 LOCATION: Pittsfield, MA (Bldg 72) STARTED: 6/29/87 COMPLETED: 6/29/87
 TOTAL DEPTH 20 ft HOLE DIAMETER: 5-3/4 in TYPE OF SAMPLE/
 DRILLED: 20 ft CORING DEVICE: split spoon
 LENGTH & DIAMETER 3' x 2" SAMPLING INTERVAL: 2 ft
 OF CORING DEVICE: 3' x 2" INTERVAL: 2 ft
 LAND-SURFACE ESTIMATED SURVEYED
 ELEVATION: ESTIMATED DATUM:
 DRILLING FLUID USED: none DRILLING METHOD: auger
 DRILLING CONTRACTOR: Soil & Mat'l Testing DRILLER: Mike HELPER: Mike
 PREPARED BY: W. Gray HAMMER WEIGHT: 140 lb HAMMER DROP: 30 in

SAMPLE NO	SAMPLE DEPTH		CORE RECVRY	BLOW COUNTS	SAMPLE/CORE DESCRIPTION
	FROM	TO			
	0	2	1.0	4-12-	Top soil. sandy, brown (3 inches).
				13-32	Sand, fine to medium (70%), some silt, some gravel. brown.
	2	4	2.0	18-40	Same as above.
				14-18	
	4	6	1.6	7-9-	Silt (70%) with fine sand, little clay, brown; some gravel and limestone fragments.
				15-30	
	6	8	2.0	22-17-	Sand (70%), some silt, some gravel, brown.
				10-10	
	8	10	2.0	4-4-	Sand, fine to medium (70%), some silt, brown.
				4-5	
	10	12	1.8	2-3-	Same as above.
				4-4	
	12	14	2.0	5-6-	Sand (90%), little silt, brown and black staining on sediments.
				7-9	
	14	16	1.5	4-5-	Black stained sand as above (3 inches).
				4-3	Silt (80%), some clay, brown-gray; moist.
	16	18	2.0	3-1-	Silt (80%), some clay, little gravel, brown-gray; moist.
				2-3	
	18	20	0.3	6-12-	Same as above.
				14-14	

SAMPLE/CORE LOG

BORING/WELL: 72-13 PROJECT NO: NO360SS2 PAGE: 1 of 1
 SITE General Electric Co. DRILLING DRILLING
 LOCATION: Pittsfield, MA (Bldg 72) STARTED: 6/29/87 COMPLETED: 6/29/87
 TOTAL DEPTH 20 ft HOLE DIAMETER: 5-3/4 in TYPE OF SAMPLE/
 DRILLED: 20 ft CORING DEVICE: split spoon
 LENGTH & DIAMETER SAMPLING
 OF CORING DEVICE: 2' x 2" INTERVAL: 2 ft
 LAND-SURFACE () SURVEYED
 ELEVATION: () ESTIMATED DATUM:
 DRILLING FLUID USED: none DRILLING METHOD: auger
 DRILLING CONTRACTOR: Soil & Mat'l Testing DRILLER: Mike HELPER: Mike
 PREPARED BY: W. Gray HAMMER WEIGHT: 140 lb HAMMER DROP: 30 in

SAMPLE NO	SAMPLE DEPTH		CORE RECVRY	BLOW COUNTS	SAMPLE/CORE DESCRIPTION
	FROM	TO			
	0	2	1.0	5-8-	Top soil, sandy, brown (3 inches).
				10-10	Sand, fine to medium (75%), some silt, little gravel.
	2	4	0.3	13-31-	Same as above.
				20-32	
	4	6	1.5	13-10-	Silt (75%) with fine sand, brown; little gravel.
				6-6	
	6	8	1.0	4-4-	Sand (80%), some silt, little gravel, light brown.
				6-7	
	8	10	1.3	3-4-	Same as above.
				5-5	
	10	12	1.5	3-3-	Sand, fine to medium (70%), with silt, brown.
				5-6	
	12	14	1.6	3-4-	Sand (90%), little silt, brown.
				3-4	
	14	16	1.5	4-4-	Same as above; moist.
				4-7	
	16	18	1.0	4-1-	Silt (80%), some clay, some gravel, brown-gray;
				3-4	moist.
	18	20	1.0	3-6-	Same as above.
				5-4	

SAMPLE/CORE LOG

BORING/WELL: 72-14 PROJECT NO: NO360SS2 PAGE: 1 of 1
 SITE General Electric Co. DRILLING DRILLING
 LOCATION: Pittsfield, MA (Bldg 72) STARTED: 6/29/87 COMPLETED: 6/29/87
 TOTAL DEPTH 20 ft HOLE DIAMETER: 5-3/4 in TYPE OF SAMPLE/
 DRILLED: 20 ft CORING DEVICE: split spoon
 LENGTH & DIAMETER OF CORING DEVICE: 2' x 2" SAMPLING INTERVAL: 2 ft
 LAND-SURFACE ELEVATION: () SURVEYED
 () ESTIMATED DATUM:
 DRILLING FLUID USED: none DRILLING METHOD: auger
 DRILLING CONTRACTOR: Soil & Mat'l Testing DRILLER: Mike HELPER: Mike
 PREPARED BY: W. Gray HAMMER WEIGHT: 140 lb HAMMER DROP: 30 in

SAMPLE NO	SAMPLE DEPTH		CORE RECVRY	BLOW COUNTS	SAMPLE/CORE DESCRIPTION
	FROM	TO			
	0	2	1.0	3-6-	Top soil, sandy, brown (3 inches).
				5-5	Sand, fine to medium (70%), some silt, some gravel.
	2	4	1.0	5-6-	Same as above.
				4-6	
	4	6	1.0	2-2-	Silt (70%) with fine sand, little gravel, brown.
				3-3	
	6	8	1.3	4-4-	Same as above.
				5-6	
	8	10	1.0	4-3-	Sand, fine to medium (70%) with silt, brown; little gravel.
				4-5	
	10	12	1.8	4-5-	Sand (80%) some silt, little gravel, brown.
				6-6	
	12	14	1.5	5-4-	Same as above (12 inches).
				5-6	Silt (80%), some fine sand, brown (6 inches).
	14	16	1.5	9-6-	Sand (80%), some silt, brown (4 inches).
				6-6	Silt (80%), some fine sand, brown (2 inches).
					Sand (80%), some silt, brown.
	16	18	0.6	5-3-	Same as above (4 inches).
				5-7	Silt (80%), some clay, brown, moist.
	18	20	1.0	12-3-	Silt (75%), some clay, little gravel, brown, moist.
				6-19	

SAMPLE/CORE LOG

BORING/WELL: 72-15 PROJECT NO: NO360SS2 PAGE: 1 of 1
 SITE General Electric Co. DRILLING DRILLING
 LOCATION: Pittsfield, MA (Bldg 72) STARTED: 6/30/87 COMPLETED: 6/30/87
 TOTAL DEPTH 20 ft HOLE 5-3/4 in TYPE OF SAMPLE/
 DRILLED: 20 ft DIAMETER: 5-3/4 in CORING DEVICE: split spoon
 LENGTH & DIAMETER OF CORING DEVICE: 2' x 2" SAMPLING INTERVAL: 2 ft
 LAND-SURFACE ELEVATION: () SURVEYED
() ESTIMATED DATUM: _____
 DRILLING FLUID USED: none DRILLING METHOD: auger
 DRILLING CONTRACTOR: Soil & Mat'l Testing DRILLER: Mike HELPER: Mike
 PREPARED BY: W. Gray HAMMER WEIGHT: 140 lb HAMMER DROP: 30 in

SAMPLE NO	SAMPLE DEPTH		CORE RECVRY	BLOW COUNTS	SAMPLE/CORE DESCRIPTION
	FROM	TO			
	0	2	1.7	4-8-	Top soil, sandy, brown (3 inches).
				12-22	Sand, fine to medium (65%); with silt, some gravel.
	2	4	1.3	28-26-	Same as above.
				25-20	
	4	6	1.0	6-6-	Same as above (3 inches).
				3-4	Sand (80%), little silt, brown (2 inches).
					Sand, fine to medium (70%), some silt, dark brown.
	6	8	1.4	5-7-	Sand (85%), little silt, brown; little gravel.
				7-10	
	8	10	1.5	7-7-	Sand (85%), little silt, some gravel; brown.
				7-7	
	10	12	2.0	4-3-	Sand (90%), little silt, brown.
				4-3	
	12	14	1.0	3-2-	Same as above (2 inches).
				6-35	Silt (75%) with fine sand, little gravel; brown; moist.
	14	16	-	25-13-	No recovery.
				27-20	
	16	18	1.5	2-1-	Silt (80%), little fine sand, some gravel, some clay.
				2-2	
	18	20	0.4	3-7-	Same as above, moist.
				6-7	

SAMPLE/CORE LOG

BORING/WELL: 72-17 PROJECT NO: NO360SS2 PAGE: 1 of 1
 SITE General Electric Co. DRILLING DRILLING
 LOCATION: Pittsfield, MA (Bldg 72) STARTED: 6/30/87 COMPLETED: 6/30/87
 TOTAL DEPTH 20 ft HOLE DIAMETER: 5-3/4 in TYPE OF SAMPLE/
 DRILLED: 20 ft CORING DEVICE: split spoon
 LENGTH & DIAMETER OF CORING DEVICE: 2' x 2" SAMPLING INTERVAL: 2 ft
 LAND-SURFACE ELEVATION: () SURVEYED () ESTIMATED DATUM: _____
 DRILLING FLUID USED: none DRILLING METHOD: auger
 DRILLING CONTRACTOR: Soil & Mat'l Testing DRILLER: Mike HELPER: Mike
 PREPARED BY: W. Gray HAMMER WEIGHT: 140 lb HAMMER DROP: 30 in

SAMPLE NO	SAMPLE DEPTH		CORE RECVRY	BLOW COUNTS	SAMPLE/CORE DESCRIPTION
	FROM	TO			
	0	2	1.0	2-8-	Fill - Top soil, sandy, brown (2 inches).
				17-24	Sand, fine to medium (65%), some silt, little gravel.
	2	4	1.3	21-15-	Fill - Same as above.
				20-15	
	4	6	1.2	6-5-	Fill - Same as above (9 inches).
				2-8	Metal fragments, red brick, fill material.
	6	8	-	6-5-	No recovery.
				7-6	
	8	10	1.3	5-7-	Sand (85%), some gravel, little silt, brown.
				7-6	
	10	12	1.2	5-5-	Same as above.
				5-5	
	12	14	2.0	5-5-	Sand (90%), little silt, brown.
				5-5	
	14	16	1.3	6-3-	Silt (80%), some clay, little gravel, brown.
				2-7	
	16	18	1.4	7-3-	Same as above.
				5-6	
	18	20	1.4	6-8-	Same as above.
				10-12	

SAMPLE/CORE LOG

BORING/WELL: 72-18 PROJECT NO: NO360SS2 PAGE: 1 of 1
 SITE General Electric Co. DRILLING DRILLING
 LOCATION: Pittsfield, MA (Bldg 72) STARTED: 6/30/87 COMPLETED: 6/30/87
 TOTAL DEPTH HOLE TYPE OF SAMPLE/
 DRILLED: 20 ft DIAMETER: 5-3/4 in CORING DEVICE: split spoon
 LENGTH & DIAMETER SAMPLING
 OF CORING DEVICE: 2' x 2" INTERVAL: 2 ft
 LAND-SURFACE () SURVEYED
 ELEVATION: () ESTIMATED DATUM: _____
 DRILLING FLUID USED: none DRILLING METHOD: auger
 DRILLING CONTRACTOR: Soil & Mat'l Testing DRILLER: Mike HELPER: Mike
 PREPARED BY: W. Gray HAMMER WEIGHT: 140 lb HAMMER DROP: 30 in

SAMPLE NO	SAMPLE DEPTH		CORE RECVRY	BLOW COUNTS	SAMPLE/CORE DESCRIPTION
	FROM	TO			
	0	2	1.7	2-22-	3" Top soil, sandy, brown (3 inches).
				14-30	Sand, fine to medium (70%), some silt, some gravel.
	2	4	1.5	15-14-	Same as above.
				18-15	
	4	6	2.0	8-8-	Same as above.
				5-5	
	6	8	1.0	3-3-	Silt (70%), with fine sand, little clay; some gravel.
				10-8	
	8	10	1.7		Same as above.
	10	12	1.3	14-16-	Sand, fine to medium (70%); some silt; some gravel.
				14-12	
	12	14	0.4	3-9-	Same as above.
				14-9	
	14	16	1.7	4-6-	Sand (70%); some silt, some gravel, little clay, brown.
				6-7	
	16	18	1.7	6-6-	Same as above.
				5-6	
	18	20	1.9	4-4-	Sand (85%), some silt, brown.
				5-8	

SAMPLE/CORE LOG

BORING/WELL: 72-28 PROJECT NO: NY0360SS03 PAGE: 1 of 1
 SITE LOCATION: Building 72 DRILLING STARTED: 2/15/89 DRILLING COMPLETED: 2/15/89
 TOTAL DEPTH DRILLED: 12 ft. HOLE DIAMETER: 4 inches TYPE OF SAMPLE/CORING DEVICE: Split-spoon
 LENGTH & DIAMETER OF CORING DEVICE: 2 ft x 2 in. SAMPLING INTERVAL: 2 feet
 LAND-SURFACE ELEVATION: () SURVEYED () ESTIMATED DATUM:
 DRILLING FLUID USED: none DRILLING METHOD: Solid Stem Auger
 DRILLING CONTRACTOR: Hanson Drilling DRILLER: Rocky HELPER: Roy
 PREPARED BY: W. Gray HAMMER WEIGHT: 140 HAMMER DROP: 30 inches

SAMPLE DEPTH (FT BELOW LAND SURFACE)		CORE RECVRY (FT)	BLOW COUNTS PER 6 INCHES	SAMPLE/CORE DESCRIPTION
FROM	TO			
0	2	1.9		Sand, medium to fine with gravel, medium, trace silt, brown and black staining pieces of logs per copper wire.
2	4	1.2		Medium to fine sand and silt, trace gravel small, trace clay, brown. Pieces of wood.
4	6	1.8		Sand, fine (75%), with silt, trace gravel, small, red brick fragments.
6	8	1.1		Sand, medium to fine, trace gravel, small, trace silt.
8	10	1.0		Sand, medium to fine, trace gravel, small trace silt.
10	12	1.3		Sand, medium to fine, trace gravel, medium to large, trace silt, brown.
				* Ground-level lowered approximately 4 ft; surface water going down borehole.

ALTRESCO PARKING AREA

NEW YORK AVENUE WATER LINE

ALTRESCO TRANSMISSION LINE



SAMPLE/CORE LOG

Boring/Well STR-1N Project/No. NY05505 Page 12 of 15

Site Location Pittsfield, MA Drilling Started 11-15-89 Drilling Completed 11-15-89

Total Depth Drilled 8 (feet)

Hole Diameter 4 (inches) Type of Sample/ Coring Device Split-barrel core

Length and Diameter of Coring Device 2' x 1.5" Sampling Interval continuous feet

Drilling Fluid Used NONE Drilling Method Hollow-stem auger

Drilling Contractor Soil & Material Testing Driller M. Sofia Helper S. Kannes

Prepared By T. Loukides Hammer Weight 140# Hammer Drop 30 inches

HNU	Sample/Core Depth (feet below land surface)		Core Recovery (feet)	Time/Hydraulic Pressure or Blows per 6 Inches	Sample/Core Description
	From	To			
ND	0	2	1.1	1-2-4-4	Silt, brown, with organic detritus (50%); grades to silt, gray-brown, micaceous (50%)
ND	2	4	1.3	6-12-9-10	Silty fine sand, brown to creme (90%); Quartzose gravel, medium to coarse, white (10%)
ND	4	6	1.4	6-4-4-4	Silty fine sand, brown to gray-brown (100%); slightly moist
ND	6	8	1.2	3-3-3-2	Silty fine sand, same as above (90%); quartzose gravel, medium to coarse, white (10%)
ND	8	10	1.3	3-3-9-10	Same as above



SAMPLE/CORE LOG

Boring/Well STR-3S Project/No. NY05505 Page 9 of 15
 Site Location Pittsfield, MA Drilling Started 11-14-89 Drilling Completed 11-14-89
 Total Depth Drilled 8 (feet)
 Hole Diameter 4 (inches) Type of Sample/ Coring Device Split-barrel core
 Length and Diameter of Coring Device 2' x 1.5" Sampling Interval continuous ~~ft~~
 Drilling Fluid Used NONE Drilling Method Hollow-stem auger
 Drilling Contractor Soil & Material Testing Driller M. Sofia Helper S. Kannes
 Prepared By T. Loukides Hammer Weight 140# Hammer Drop 30 inches

	Sample/Core Depth (feet below land surface)		Core Recovery (feet)	Time/Hydraulic Pressure or Blows per 6 inches	Sample/Core Description
	From	To			
HNU ND	0	2	1.0	1-3-2-3	Silty fine sand, brown to dark brown (90% root fragments and rock chips
ND	2	4	1.4	3-3-3-3	Sand, fine, brown to salt and pepper (100%)
ND	4	6	1.5	4-4-3-3	Silt, olive-brown (90%); trace fine rounded gravel and varicolored mottling throughout
ND	6	8	1.4	4-5-6-6	Silt, same as above (100%); moist
ND	8	10	1.6	6-8-8-10	Same as above



SAMPLE/CORE LOG

Boring/Well STR-3S2 Project/No. NY05505 Page 10 of 15
 Site Pittsfield, MA Drilling Started 11-14-89 Drilling Completed 11-14-89
 Total Depth Drilled 3 (feet)
 Hole Diameter 4 (inches) Type of Sample/ Coring Device Split-barrel core
 Length and Diameter of Coring Device 3' x 1.5" Sampling Interval continuous feet
 Drilling Fluid Used NONE Drilling Method Hollow-stem auger
 Drilling Contractor Soil & Material Testing Driller M. Sofia Helper S. Kannes
 Prepared By T. Loukides Hammer Weight 140# Hammer Drop 30 inches

	Sample/Core Depth (feet below land surface)		Core Recovery (feet)	Time/Hydraulic Pressure or Blows per 6 inches	Sample/Core Description
	From	To			
HNU					
ND	0	2	0.9	1-2-2-2	Silt, dark brown (85%); cinder, coal, and rock fragments (10%)
ND	2	4	1.3	4-6-9-9	Sand, fine, brown (100%); moist
ND	4	6	1.2	7-7-5-5	Sand, fine to medium, brown to salt and pepper (100%)
ND	6	8	1.3	4-3-3-4	Silt, brown to olive-brown, moderately dense, micaceous (95%); trace fine gravel and varicolored mottling
ND	8	10	1.4	4-4-5-4	Same as above

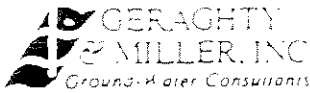

SAMPLE/CORE LOG

Boring/Well STR-3N1 Project/No. NY05505 Page 5 of 15
 Site Location Pittsfield, MA Drilling Started 11-14-89 Drilling Completed 11-14-89
 Total Depth Drilled 8 (feet)
 Hole Diameter 4 (inches) Type of Sample/ Coring Device Split-barrel core
 Length and Diameter of Coring Device 2' x 1.5" Sampling Interval continuous feet
 Drilling Fluid Used NONE Drilling Method Hollow-stem auger
 Drilling Contractor Soil & Material Testing Driller M. Sofia Helper S. Kannes
 Prepared By T. Loukides Hammer Weight 140# Hammer Drop 30 inches

HNU	Sample/Core Depth (feet below land surface)		Core Recovery (feet)	Time/Hydraulic Pressure or Blows per 6 inches	Sample/Core Description
	From	To			
ND	0	2	1.0	1-2-3-3	Sand, fine, brown (80%); silt, dark brown, with plant root fragments (20%)
ND	2	4	1.8	4-4-4-5	Sand, fine, brown to salt and pepper (100%); micaceous in places
ND	4	6	1.7	6-6-6-6	Same as above
ND	6	8	1.4	6-7-6-7	Clayey silt, olive-brown to gray (65%); with fine to medium gravel embedded (30%); wet @ 8'
ND	8	10	1.2	8-10-6-17	Silt, same as above (50%); sand, same as above (40%); fine rounded gravel throughout

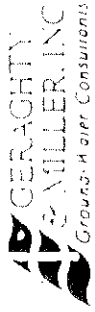

SAMPLE/CORE LOG

Boring/Well STR-3SL Project/No. NY05505 Page 3 of 15
 Site Location Pittsfield, MA Drilling Started 11-14-89 Drilling Completed 11-14-89
 Total Depth Drilled 8 (feet) Type of Sampler/ Coring Device Split-barrel core
 Hole Diameter 4 (inches) Sampling Interval continuous feet
 Length and Diameter of Coring Device 3' X 1.5"
 Drilling Fluid Used NONE Drilling Method Hollow-stem auger
 Drilling Contractor Soil & Material Testing Driller M. Sofia Heiber S. Kannes
 Prepared By T. Loukides Hammer Hammer Weight 140# Drop 30 inches

Sample/Core Depth (feet below land surface)	Sample/Core Depth		Time/Hydraulic Pressure or Blows per 6 inches	Sample/Core Description
	From	To		
ND	0	2	1.2	1-2-2-3 Silty fine sand, brown (50%) to dark brown (50%); plant root fragments
ND	2	4	1.7	3-4-5-6 Sand, fine, brown to salt and pepper (100%)
ND	4	6	1.2	6-5-5-5 Silt, gray-brown to olive-brown (70%); sand, same as above (30%)
ND	6	8	1.5	6-6-8-10 Sand, fine, light brown (80%), (wee); silt, same as above (20%)
ND	8	10	1.8	10-10-11-14 Sand, same as above (70%); grades to silt, gray-brown, dense, dry, @ 9'

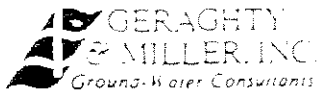

SAMPLE/CORE LOG

Boring/Well STR-3N Project/No. NY05505 Page 6 of 15
 Site Location Pittsfield, MA Drilling Started 11-14-89 Drilling Completed 11-14-89

Total Depth Drilled 8 (feet)
 Hole Diameter 4 (inches) Type of Sample/ Coring Device Split-barrel core
 Length and Diameter of Coring Device 2' x 1.5" Sampling Interval continuous

Drilling Fluid Used NONE Drilling Method Hollow-stem auger
 Drilling Contractor Soil & Material Testing Driller M. Sofia Helper S. Kannes
 Prepared By T. Loukides Hammer Weight 140# Hammer Drop 30 inches

	Sample/Core Depth (feet below land surface)		Core Recovery (feet)	Time/Hydraulic Pressure or Blows per 6 inches	Sample/Core Description
	From	To			
HNU					
ND	0	2	1.0	1-2-6-6	Silty fine sand, brown to dark brown (90%); trace root fragments
ND	2	4	1.6	4-3-2-2	Sand, fine, brown to salt and pepper (100%)
ND	4	6	1.1	2-2-2-9	Sand, same as above (90%); plug of olive-brown silt in shoe of spoon
ND	6	8	1.6	10-4-4-6	Silt, brown to olive-brown, moderately dense (85%); gravel, medium to coarse, rounded (15%); varicolored mottling; moist
ND	8	10	1.7	6-8-10-11	Silt, gray to gray-brown, dense (90%); seams of moist, fine gray sand

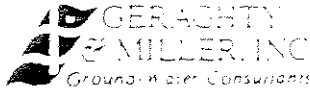

SAMPLE/CORE LOG

Boring/Well STR-3N2 Project/No. NY05505 Page 01 of 15
 Site Location Pittsfield, MA Drilling Started 11-14-89 Drilling Completed 11-14-89

Total Depth Drilled 8 (feet)
 Hole Diameter 4 (Inches) Type of Sample/ Coring Device Split-barrel core
 Length and Diameter of Coring Device 2' x 1.5" Sampling Interval continuous ~~ft~~

Drilling Fluid Used NONE Drilling Method Hollow-stem auger
 Drilling Contractor Soil & Material Testing Driller M. Sofia Helper S. Kannes
 Prepared By T. Loukides Hammer Weight 140# Hammer Drop 30 inches

	Sample/Core Depth (feet below land surface)		Core Recovery (feet)	Time/Hydraulic Pressure or Blows per 6 inches	Sample/Core Description
	From	To			
ND	0	2	1.1	1-2-3-3	Silty fine sand, dark brown (90%); root fragments and wood chips @ top
ND	2	4	1.8	3-3-3-3	Sand, fine, brown to salt and pepper (100%); slightly moist
ND	4	6	1.9	3-3-4-6	Same as above; plug of gray-brown silt in shoe of spoon
ND	6	8	1.7	4-3-6-10	Silt, olive-brown, moderately dense (90%); fine to medium rounded gravel clasts and varicolored mottling; slightly moist
ND	8	10	1.8	11-11-12-12	Same as above but dry and tight

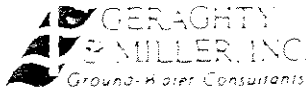

SAMPLE/CORE LOG

Boring/Well STR-4S Project/No NY05505 Page 2 of 15

Site Pittsfield, MA Drilling Started 11-14-89 Drilling Completed 11-14-89
 Location Pittsfield, MA

Total Depth Drilled 8 (feet)

Hole Diameter 4 (inches) Type of Sample/ Coring Device Split-barrel core

Length and Diameter of Coring Device 2' x 1.5" Sampling Interval continuous-feet

Drilling Fluid Used NONE Drilling Method Hollow-stem auger

Drilling Contractor Soil & Material Testing Driller M. Sofia Helper S. Kannes

Prepared By T. Loukides Hammer Weight 140# Hammer Drop 30 inches

	Sample/Core Depth (feet below land surface)		Core Recovery (feet)	Time/Hydraulic Pressure or Blows per 6 inches	Sample/Core Description
	From	To			
HNU					
ND	0	2	1.0	2-3-4-6	Sand, fine, light brown to creme (80%); silt, brown to dark brown (20%)
ND	2	4	1.4	2-2-4-7	Silt, brown to olive-brown (80%), micaceous; sand fine, salt and pepper (20%); orange and black mottling
ND	4	6	1.3	9-11-8-9	Same as above; silt more dense, moist
ND	6	8	1.5	7-6-3-5	Sand, fine, brown (50%), salt and pepper (50%); wet @ 8'
ND	8	10	1.9	6-7-11-10	Same as above; wet

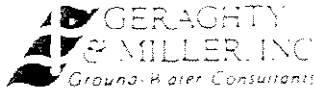

SAMPLE/CORE LOG

Boring/Well STR-4N2 Project/No. NY05505 Page 3 of 15
 Site Location Pittsfield, MA Drilling Started 11-14-89 Drilling Completed 11-14-89

Total Depth Drilled 8 (feet)
 Hole Diameter 4 (inches) Type of Sample/ Coring Device Split-barrel core
 Length and Diameter of Coring Device 2' x 1.5" Sampling Interval continuous feet

Drilling Fluid Used NONE Drilling Method Hollow-stem auger
 Drilling Contractor Soil & Material Testing Driller M. Sofia Helper S. Kannes
 Prepared By T. Loukides Hammer Weight 140# Hammer Drop 30 inches

HNU	Sample/Core Depth (feet below land surface)		Core Recovery (feet)	Time/Hydraulic Pressure or Blows per 6 inches	Sample/Core Description
	From	To			
ND	0	2	0.7	1-3-5-7	Sand, fine, light, brown to creme, (60%); silt, brown (40%)
ND	2	4	1.3	6-9-7-11	Sand, fine, brown (90%); rust-orange mottling throughout; micaceous
ND	4	6	1.9	8-7-6-5	Sand, fine, brown to salt and pepper (95%); trace fine gravel; micaceous
ND	6	8	1.2	7-10-10-9	Silt, brown (50%); sand, fine, brown to salt and pepper (45%); micaceous; moist
ND	8	10	1.4	8-10-9-6	Silt, brown (60%); sand fine, salt and pepper (35%); micaceous; wet @ 9'



SAMPLE/CORE LOG

Boring/Well STR-452 Project/No. NY05505 Page 4 of 15
 Site Location Pittsfield, MA Drilling Started 11-14-89 Drilling Completed 11-14-89

Total Depth Drilled 8 (feet)
 Hole Diameter 4 (inches) Type of Sample/ Coring Device Split-barrel core
 Length and Diameter of Coring Device 2' x 1.5" Sampling Interval continuous ~~xxx~~

Drilling Fluid Used NONE Drilling Method Hollow-stem auger
 Drilling Contractor Soil & Material Testing Driller M. Sofia Helper S. Kannes
 Prepared By T. Loukides Hammer Weight 140# Hammer Drop 30 inches

	Sample/Core Depth (feet below land surface)		Core Recovery (feet)	Time/Hydraulic Pressure or Blows per 6 inches	Sample/Core Description
	From	To			
HNU					
ND	0	2	1.8	1-2-2-3	Silt, brown to dark brown (50%); sand, fine, light brown to brown (50%)
ND	2	4	1.1	3-5-5-9	Silty fine sand, brown (100%); purple- brown mottling in places
ND	4	6	2.0	6-5-5-4	Silt, gray-brown, moderately dense, micaceous (65%); sand, fine, salt and pepper (30%); trace fine gravel
ND	6	8	1.8	3-3-5-5	Silty fine sand, brown to gray-brown (100%); micaceous; wet @ 7.5'
ND	8	10	1.8	4-5-3-5	Sand, fine, gray-brown to salt and pepper (100%); micaceous; wet

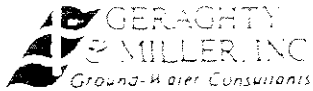

SAMPLE/CORE LOG

Boring/Well STR-1N Project/No. NY05505 Page 12 of 15
 Site Location Pittsfield, MA Drilling Started 11-15-89 Drilling Completed 11-15-89

Total Depth Drilled 8 (feet)
 Hole Diameter 4 (inches) Type of Sample/ Coring Device Split-barrel core
 Length and Diameter of Coring Device 2' x 1.5" Sampling Interval continuous feet

Drilling Fluid Used NONE Drilling Method Hollow-stem auger
 Drilling Contractor Soil & Material Testing Driller M. Sofia Helper S. Kannes
 Prepared By T. Loukides Hammer Weight 140# Hammer Drop 30 inches

	Sample/Core Depth (feet below land surface)		Core Recovery (feet)	Time/hydraulic Pressure or Blows per 6 inches	Sample/Core Description
	From	To			
HNU					
ND	0	2	1.1	1-2-4-4	Silt, brown, with organic detritus (50%); grades to silt, gray-brown, micaceous (50%)
ND	2	4	1.3	6-12-9-10	Silty fine sand, brown to creme (90%); Quartzose gravel, medium to coarse, white (10%)
ND	4	6	1.4	6-4-4-4	Silty fine sand, brown to gray-brown (100%); slightly moist
ND	6	8	1.2	3-3-3-2	Silty fine sand, same as above (90%); quartzose gravel, medium to coarse, white (10%)
ND	8	10	1.3	3-3-9-10	Same as above

NEW YORK AVENUE MONITORING WELLS

SAMPLE/CORE LOG

WELL: NY-1 PROJECT NO: NY360NY01 New York Ave. PAGE: 1 of 1
 SITE General Electric DRILLING General Electric DRILLING
 LOCATION: Pittsfield, MA STARTED: 4/25/88 COMPLETED: 4/25/88
 TOTAL DEPTH 14 ft HOLE 8 in. TYPE OF SAMPLE/
 DRILLED: 14 ft DIAMETER: 8 in. CORING DEVICE: Split Spoon
 LENGTH & DIAMETER 2 ft x 2 in. SAMPLING 2 ft
 OF CORING DEVICE: 2 ft x 2 in. INTERVAL: 2 ft
 LAND-SURFACE () SURVEYED
 ELEVATION: () ESTIMATED DATUM: _____
 DRILLING FLUID USED: None DRILLING METHOD: Hollow Stem Auger
 DRILLING Soil & Mat'l. Testing DRILLER: Tom HELPER: Bob
 CONTRACTOR: Soil & Mat'l. Testing DRILLER: Tom HELPER: Bob
 PREPARED BY: W. Gray HAMMER WEIGHT: 140 lb HAMMER DROP: 30 in.

SAMPLE NO	SAMPLE DEPTH		CORE RECVRY	BLOW COUNTS	SAMPLE/CORE DESCRIPTION
	FROM	TO			
	0	2	0.9	4-10-	Sand, medium to fine (80%); with silt, some small gravel, little clay, brown (fill).
				12-15	
	2	4	1.1	9-7-	Sand (90%), brown, 6 in. of crushed lime, gray at base (fill).
				4-1	
	4	6	1.0	1-1	Sand (85%), little silt and clay, brown, moist (fill).
				1-0	
	6	8	1.4	7-3-	Sand, fine to medium, silty, trace gravel, brown (fill - 6 to 7 ft). Sand, medium to fine, some silt, gray (7 to 8 ft).
				1-5	
	8	10	1.6	4-4-	Sand, medium to fine, some silt, gray.
				2-2	
	10	12	2.0	2-4-	1 ft as above; 1 ft peat, brown, moist.
				3-3	
	12	14	1.7	3-4-	Sand (85%), little silt, gray, wet, some peat material.
				4-4	

SAMPLE/CORE LOG

WELL: NY-2 PROJECT NO: NY360NY01 PAGE: 1 of 1
 New York Ave.
 SITE General Electric DRILLING DRILLING
 LOCATION: Pittsfield, MA STARTED: 4/26/88 COMPLETED: 4/26/88
 TOTAL DEPTH 24 ft HOLE DIAMETER: 8 in. TYPE OF SAMPLE/
 DRILLED: 24 ft CORING DEVICE: Split Spoon
 LENGTH & DIAMETER 2 ft x 2 in. SAMPLING
 OF CORING DEVICE: 2 ft x 2 in. INTERVAL: 2 ft
 LAND-SURFACE () SURVEYED
 ELEVATION: () ESTIMATED DATUM: _____
 DRILLING FLUID USED: None DRILLING METHOD: Hollow Stem Auger
 DRILLING
 CONTRACTOR: Soil & Mat'l. Testing DRILLER: Tom HELPER: Bob
 PREPARED BY: W. Gray HAMMER WEIGHT: 140 lb HAMMER DROP: 30 in.

SAMPLE NO	SAMPLE DEPTH		CORE RECVRY	BLOW COUNTS	SAMPLE/CORE DESCRIPTION
	FROM	TO			
	0	2	0.6	2-3-	Sand, medium to fine (90%); trace silt, little
				3-4	gravel, brown.
	2	4	1.0	4-4-	Sand (95%), poorly sorted; trace silt; little gravel,
				5-7	light brown.
	4	6	1.5	6-6-	Sand (85%), trace silt; increased gravel, small,
				5-5	light brown.
	6	8	1.5	10-8-	Same as above.
				8-10	
	8	10	1.6	10-12-	Same as above, gray-brown.
				12-12	
	10	12	2.0	12-6-	Same as above.
				7-7	
	12	14	0.4	12-8-	Same as above (2 in.). Fine sand and silt, trace
				7-22	clay, moist.
	14	16	0.4	8-10-	Sand, medium to fine (80%); some silt, little clay;
				8-8	little gravel, brown, moist
	16	18	1.1	12-11-	Same as above, with silt, increased gravel. Wet
				24-30	fragments of limestone at 18 ft.
	18	20	1.7	15-19-	Same as above, very silty.
				32-39	
	20	22	1.6	12-27-	Same as above.
				32-50	
	22	24	1.3	25-33-	Sand, fine, and silt; some gravel; very dense, drier
				47-97	than above, brown.

SAMPLE/CORE LOG

WELL: NY-3 PROJECT NO: NY360NY01 PAGE: 1 of 2
 New York Ave.
 SITE General Electric DRILLING DRILLING
 LOCATION: Pittsfield, MA STARTED: 4/27/88 COMPLETED: 4/27/88
 TOTAL DEPTH HOLE TYPE OF SAMPLE/
 DRILLED: 25 ft DIAMETER: 8 in. CORING DEVICE: Split Spoon
 LENGTH & DIAMETER SAMPLING
 OF CORING DEVICE: 2 ft x 2 in. INTERVAL: continuous
 LAND-SURFACE () SURVEYED
 ELEVATION: ESTIMATED DATUM:
 DRILLING FLUID USED: None DRILLING METHOD: Hollow Stem Auger
 DRILLING
 CONTRACTOR: Soil & Mat'l. Testing DRILLER: Mike HELPER: Bob
 PREPARED BY: J. Duminuco HAMMER WEIGHT: 140 lb HAMMER DROP: 30 in.

SAMPLE NO	SAMPLE DEPTH		CORE RECVRY	BLOW COUNTS	SAMPLE/CORE DESCRIPTION
	FROM	TO			
	0	2	1.2	2-4-	Sand, fine, trace silt, gravel, vegetation, brown.
				9-6	
	2	4	1.7	5-4-	Sand, fine, some silt, brown.
				4-4	
	4	6	2.0	4-3-	Do
				3-3	
	6	8	1.8	3-3-	Do, trace gravel.
				4-6	
	8	10	1.6	12-14-	Sand, fine, some silt, trace gravel, brown-gray.
				18-15	
	10	12	1.0	16-17-	Sand, fine to medium, some silt, gravel, brown-gray.
				19-12	
	12	14	0.9	16-17-	Do
				12-9	
	14	16	1.2	6-6-	Do 14 to 15.8 ft; silt, some fine sand, brown,
				8-9	(15.8 to 16 ft), wet at tip.
	16	18	1.0	6-10-	(Interlayered) sand, fine, silty and sand fine to
				11-11	medium, trace silt, gravel, brown; (wet).
	18	20	1.4	10-10-	Silt, some fine sand, brown.
				10-16	
	20	22	0.9	13-13-	Sand, fine to medium, silty, some gravel, brown.
				14-14	
	22	24	1.4	18-26-	Silt, some fine sand, trace gravel, brown.
				17-20	

SAMPLE/CORE LOG

WELL: NY-4 PROJECT NO: NY360NY01 PAGE: 1 of 1
 New York Ave.
 SITE General Electric DRILLING DRILLING
 LOCATION: Pittsfield, MA STARTED: 5/2/88 COMPLETED: 5/2/88
 TOTAL DEPTH HOLE TYPE OF SAMPLE/
 DRILLED: 33 ft DIAMETER: 8 in. CORING DEVICE: Split Spoon
 LENGTH & DIAMETER SAMPLING
 OF CORING DEVICE: 2 ft x 2 in. INTERVAL: continuous
 LAND-SURFACE SURVEYED
 ELEVATION: () ESTIMATED DATUM:
 DRILLING FLUID USED: None DRILLING METHOD: Hollow Stem Auger
 DRILLING CONTRACTOR: Soil & Mat'l. Testing DRILLER: Tom HELPER: Bob
 PREPARED BY: J. Duminuco HAMMER WEIGHT: 140 lb HAMMER DROP: 30 in.

SAMPLE NO	SAMPLE DEPTH		CORE RECVRY	FLOW COUNTS	SAMPLE/CORE DESCRIPTION
	FROM	TO			
	0	2	1.0	1-2- 2-2	Sand, fine to medium, trace gravel, silt, vegetation, brown.
	2	4	1.1	3-3- 3-4	Sand, fine to coarse, some gravel, trace silt, brown-gray.
	4	6	1.2	6-9- 6-7	Interlayered: sand, fine to coarse, some gravel, trace silt; sand, fine, silty; silt, sandy; brown.
	6	8	1.4	9-18- 16-18	Sand, fine to medium, silty and gravel, brown (damp).
	8	10	1.4	15-15- 19-14	Silt, sandy, trace gravel, brown; (wet).
	10	12	0.0	20-25- 40-120	No recovery - pushing cobbles - augered to 14.0 ft.
	14	16	1.0	11-9- 12-17	(Interlayered) Sand, fine, silty and silt, sandy, brown; (damp).
	16	18	0.9	16-20- 22-27	Silt, some fine sand, trace gravel, brown.
	18	20	0.8	29-50- 45-45	Sand, fine, some silt, trace gravel, brown; (damp).
	20	22	1.8	70-75- 50-70	Do
	22	24	1.1	11-16- 32-37	Sand, fine, trace silt, brown; (damp).

APPENDIX B
AERIAL PHOTOGRAPHS

WINTER 1953-54



OCTOBER 31, 1979

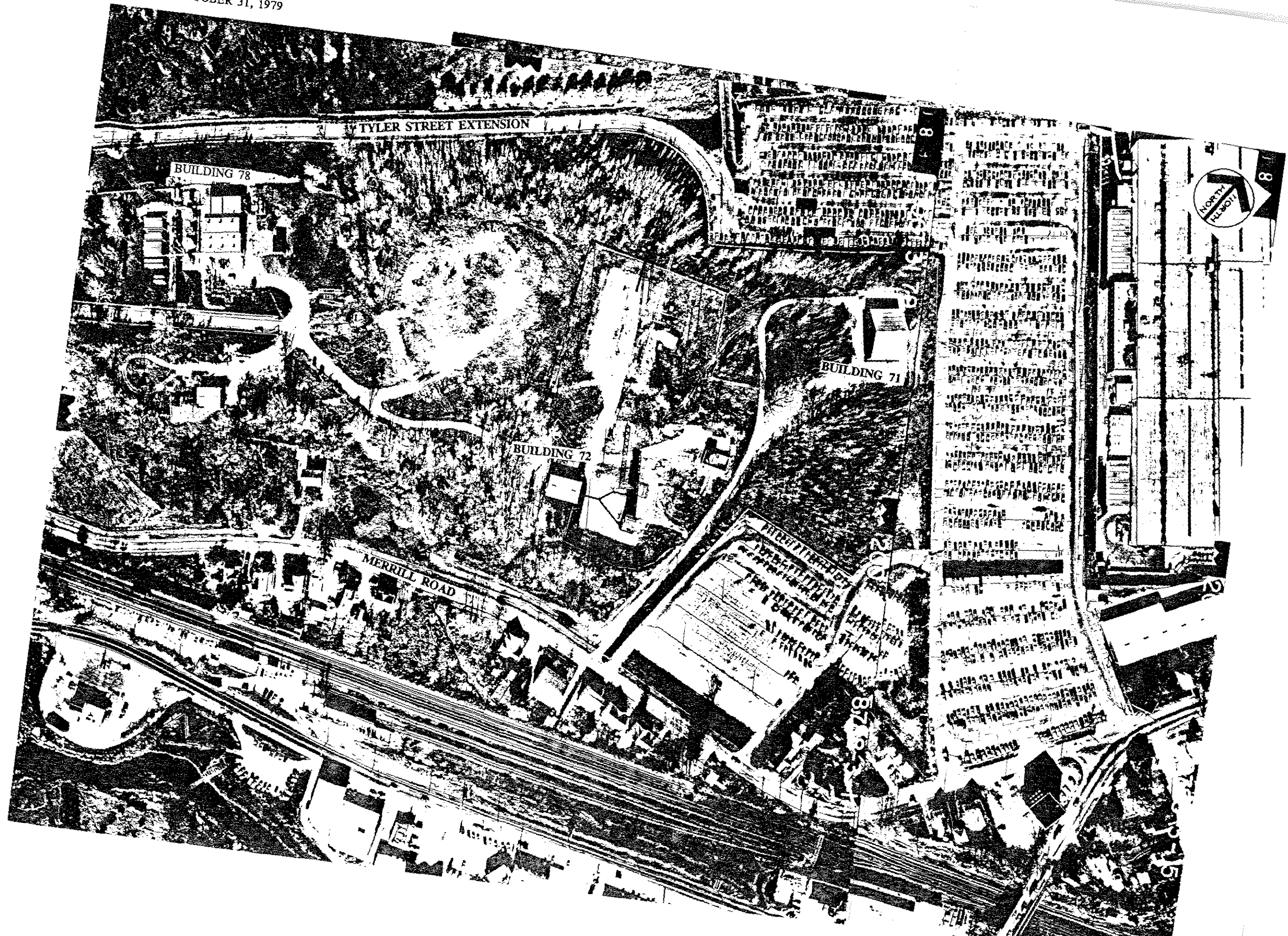

APRIL 9, 1943

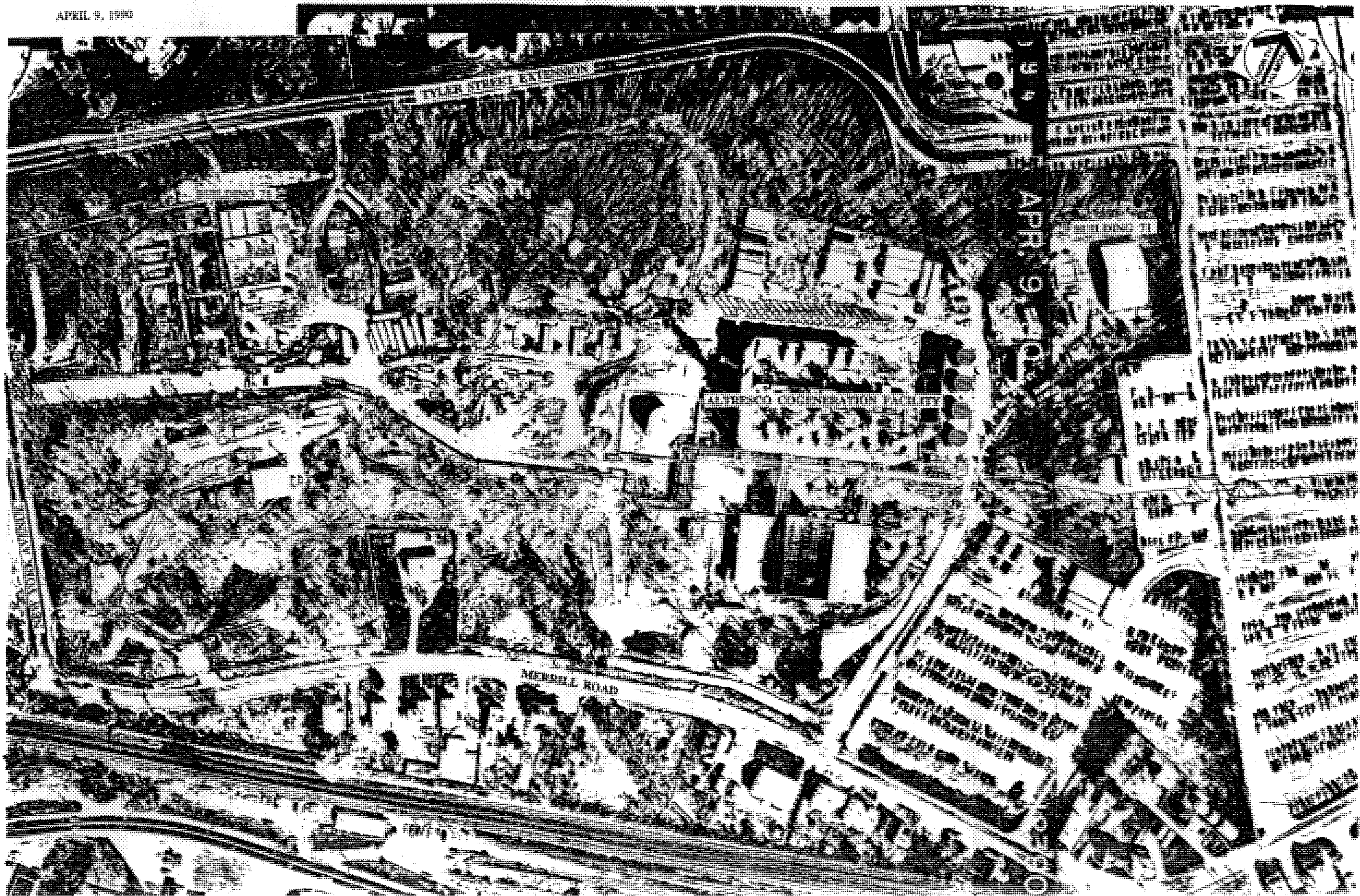

APPENDIX C
HILL 78 TOPOGRAPHIC MAPS

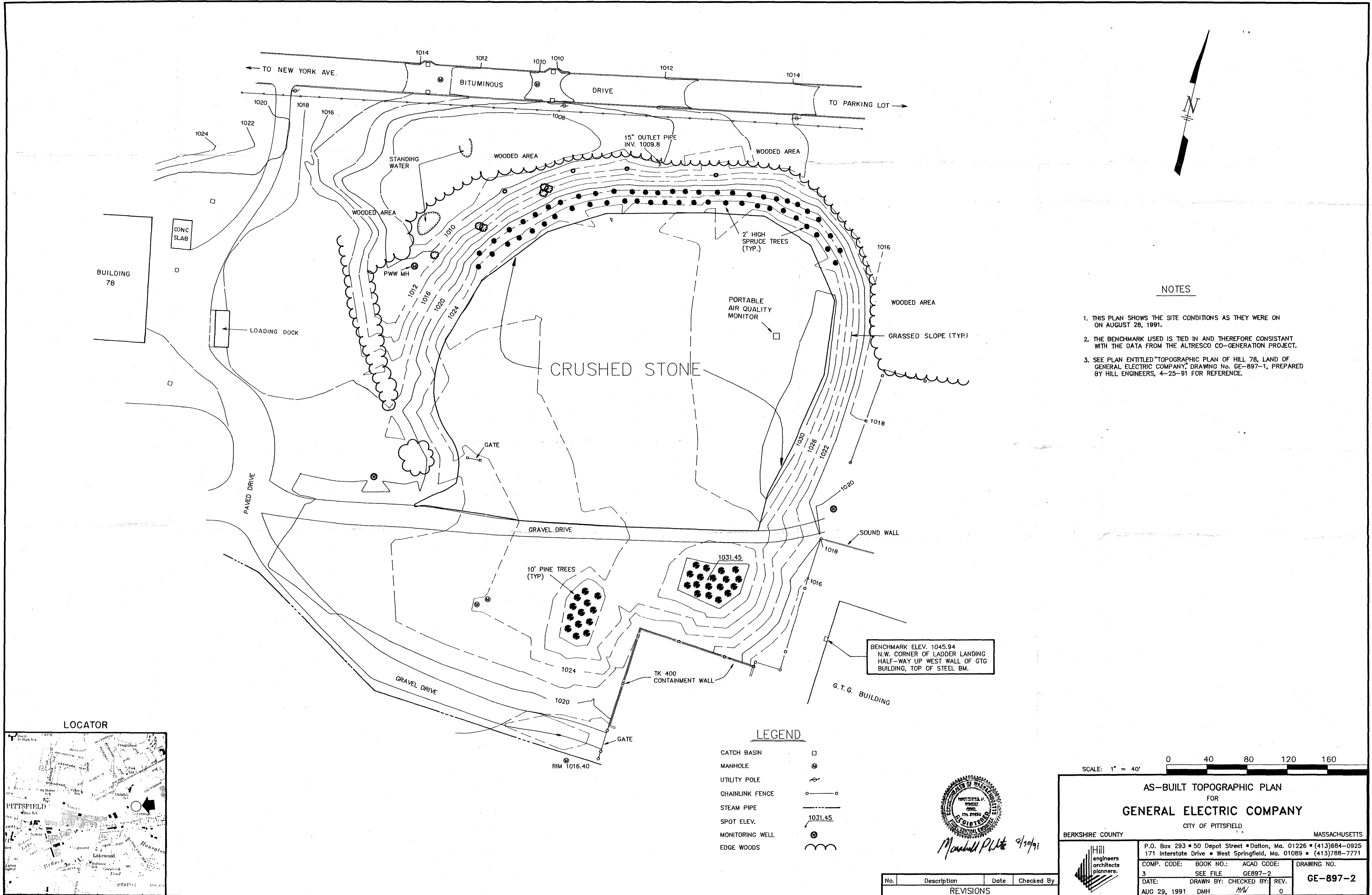

NOTES

1. THIS PLAN SHOWS THE SITE CONDITIONS AS THEY WERE ON ON AUGUST 28, 1991.
2. THE BENCHMARK USED IS TIED IN AND THEREFORE CONSISTANT WITH THE DATA FROM THE ALTRESCO CO-GENERATION PROJECT.
3. SEE PLAN ENTITLED "TOPOGRAPHIC PLAN OF HILL 78, LAND OF GENERAL ELECTRIC COMPANY," DRAWING No. GE-897-1, PREPARED BY HILL ENGINEERS, 4-25-91 FOR REFERENCE.

LOCATOR

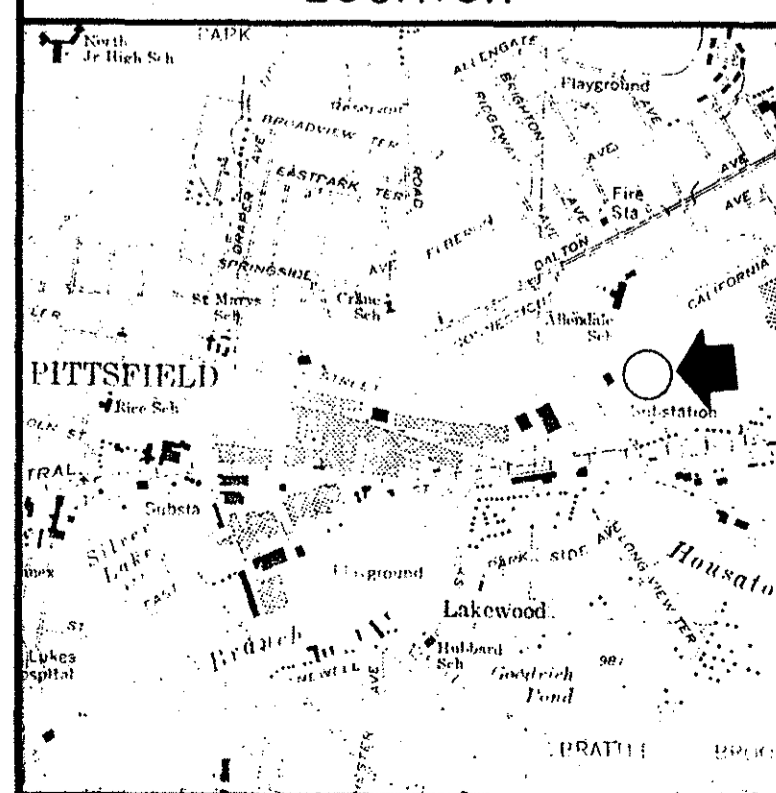

LEGEND

- CATCH BASIN
- MANHOLE
- UTILITY POLE
- CHAINLINK FENCE
- STEAM PIPE
- SPOT ELEV.
- MONITORING WELL
- EDGE WOODS

BENCHMARK ELEV. 1045.94
N.W. CORNER OF LADDER LANDING
HALF-WAY UP WEST WALL OF GTG
BUILDING, TOP OF STEEL BM.

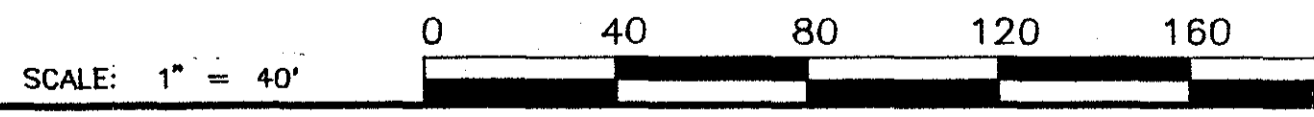

AS-BUILT TOPOGRAPHIC PLAN
FOR
GENERAL ELECTRIC COMPANY
CITY OF PITTSFIELD
MASSACHUSETTS







P.O. Box 293 • 50 Depot Street • Dalton, Ma. 01226 • (413)684-0925
171 Interstate Drive • West Springfield, Ma. 01089 • (413)788-7771

COMP. CODE: 3	BOOK NO.: SEE FILE	ACAD CODE: GE897-2	DRAWING NO. GE-897-2
DATE: AUG 29, 1991	DRAWN BY: DMH	CHECKED BY: M/A	REV. 0

No.	Description	Date	Checked By
REVISIONS			

LEASE BOUNDARY

LEGEND

-  3" THICK ASPHALT CONCRETE PAVING
-  4" COMPACTED BASE MATERIAL
-  UNPAVED AREA
-  EXISTING CONTOURS
-  PROPOSED CONTOURS
-  PROPOSED CONTOURS-COMPLETED AS OF 2/6/90
-  FLOW DIRECTION

GENERAL NOTES

1. Elevations based on USGS.
2. Topographic survey performed by HMM Associates, Inc., September 1988 and February 1990.
3. All permanent cut or fill slopes are 2 horizontal to 1 vertical unless otherwise noted.
4. This plan is based upon spot elevation shown on plans entitled "Rough Grading Plan - 505500-50062 A Rev. 0" and "Final Grading and Construction Plan - 505500-50062 A Rev. 0" prepared by Fluor Daniel.
5. This plan is issued by HMM Associates, Inc. solely for the proposed grading areas as indicated by the proposed contours. All other proposed site features including pavements, drainage system structures and the like are compiled from the drawings referenced above and are not to be constructed from this drawing.
6. Loam and seed all areas disturbed by construction activities except as shown on the "Planting Plan".
7. The intent of the graded berms is, and the contractor shall, provide 4 feet of loam over existing grade. Excavation below existing grades is not intended and any such excavation requires prior written approval of Altresco Pittsfield LP and the General Electric Company.

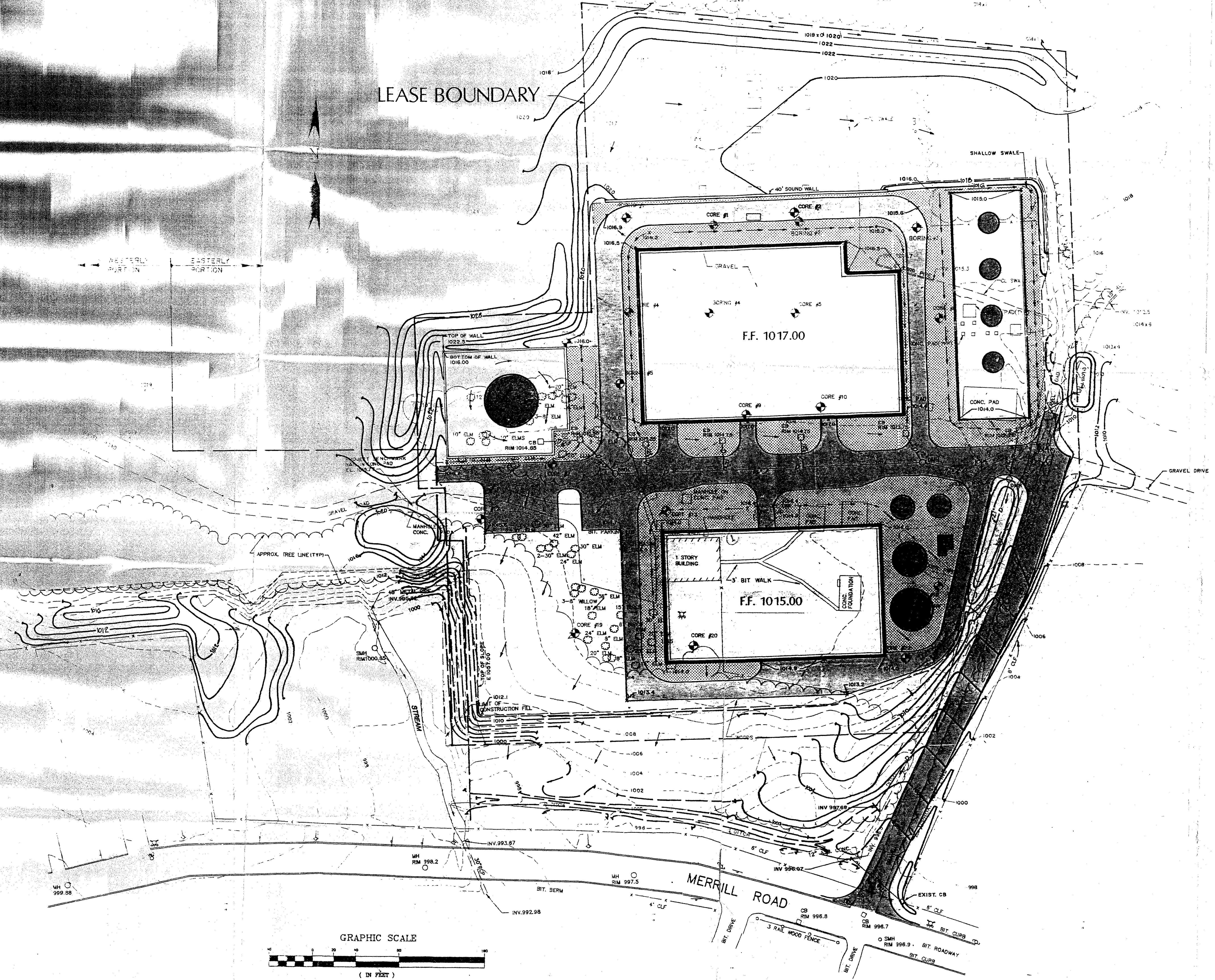

**EXHIBIT III
TOPOGRAPHIC MAP**

(per Section 7.303)

PROJECT: ALTRESCO COGENERATION FACILITY
AT GE PITTSFIELD

APPLICANT: ALTRESCO PITTSFIELD LP
600 South Cherry St. Suite 1200
Denver, Colorado 80222

OWNER: GENERAL ELECTRIC

DATE: MAY 17, 1990 (Revised)



APPENDIX D

**EXISTING DRAINAGE SITE PLAN
HILL 78, DECEMBER 1990**

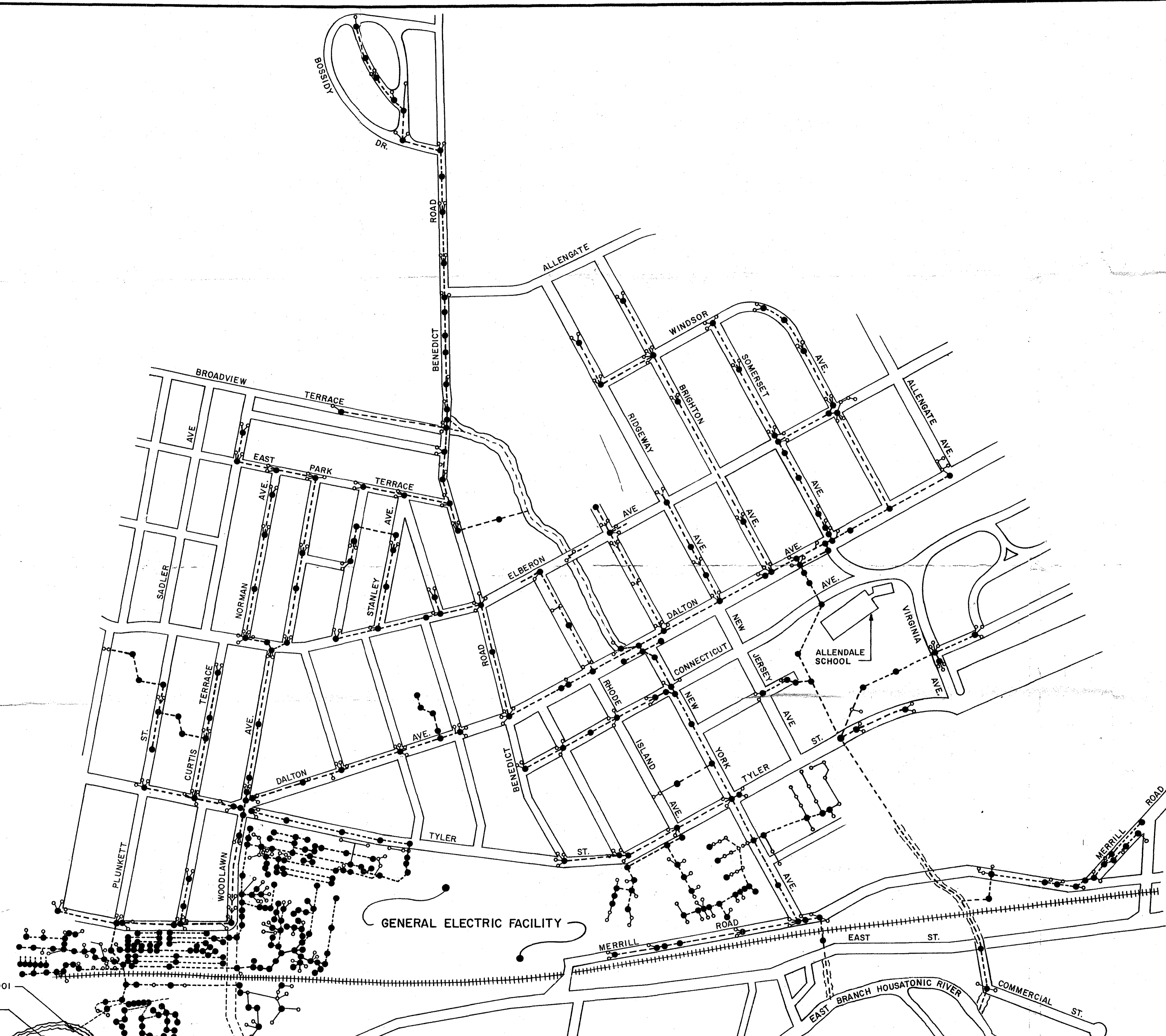

- LEGEND**
- CATCH BASIN
 - - - EXISTING STORM WATER SEWER LINE & MANHOLE
 - ==== OPEN CHANNEL

NOTE: THE INFORMATION PRESENTED IN THIS FIGURE IS NOT CONFIRMED. THE STORMWATER SYSTEM DESCRIPTION WAS OBTAINED FROM THE CITY OF PITTSFIELD'S STORMWATER DRAINAGE MAPS AND GE'S PLANT DRAINAGE SYSTEM MAPS.

OUTFALL 001
SILVER LAKE

GENERAL ELECTRIC FACILITY

MERRILL ROAD
EAST BRANCH HOUSATONIC RIVER
COMMERCIAL ST.

APPROX. SCALE - 1" = 300'

No	Date	Revisions	Init

In charge of _____
 Designed by _____
 Drawn by _____
 Checked by _____

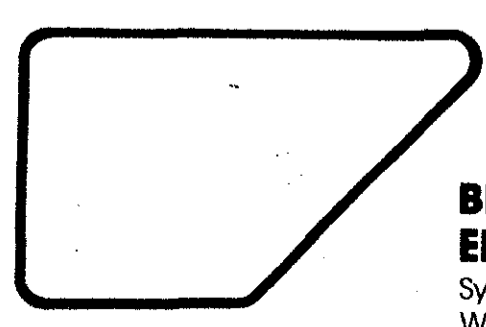

BLASLAND & BOUCK ENGINEERS, P.C.
 Syracuse, New York
 White Plains, New York

GENERAL ELECTRIC COMPANY • PITTSFIELD, MASSACHUSETTS

EXISTING DRAINAGE SITE PLAN

File Number 101.94.99
Date DECEMBER 1990

100225

APPENDIX E
UTILITIES PLANS

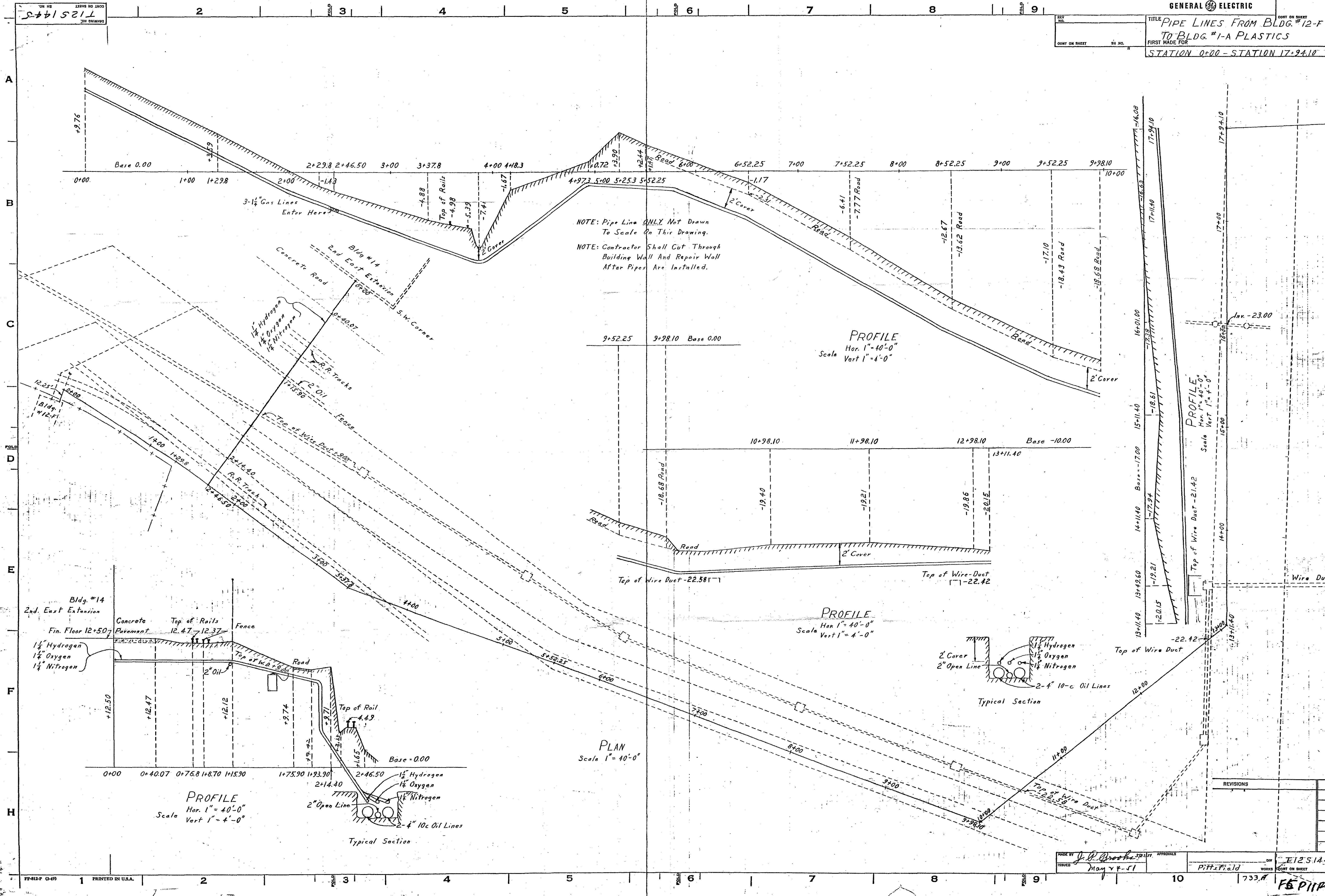

NOTE: Pipe Line ONLY Not Drawn To Scale On This Drawing.
NOTE: Contractor Shall Cut Through Building Wall And Repair Wall After Pipes Are Installed.

PROFILE
Hor. 1"=40'-0"
Vert 1"=4'-0"

PROFILE
Hor. 1"=40'-0"
Vert 1"=4'-0"

PROFILE
Hor. 1"=40'-0"
Scale Vert 1"=4'-0"

PLAN
Scale 1"=40'-0"

PROFILE
Hor. 1"=40'-0"
Scale Vert 1"=4'-0"

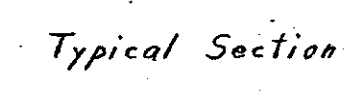
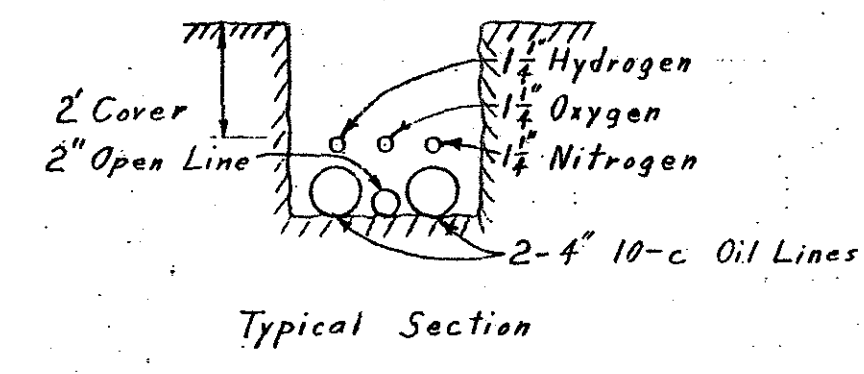
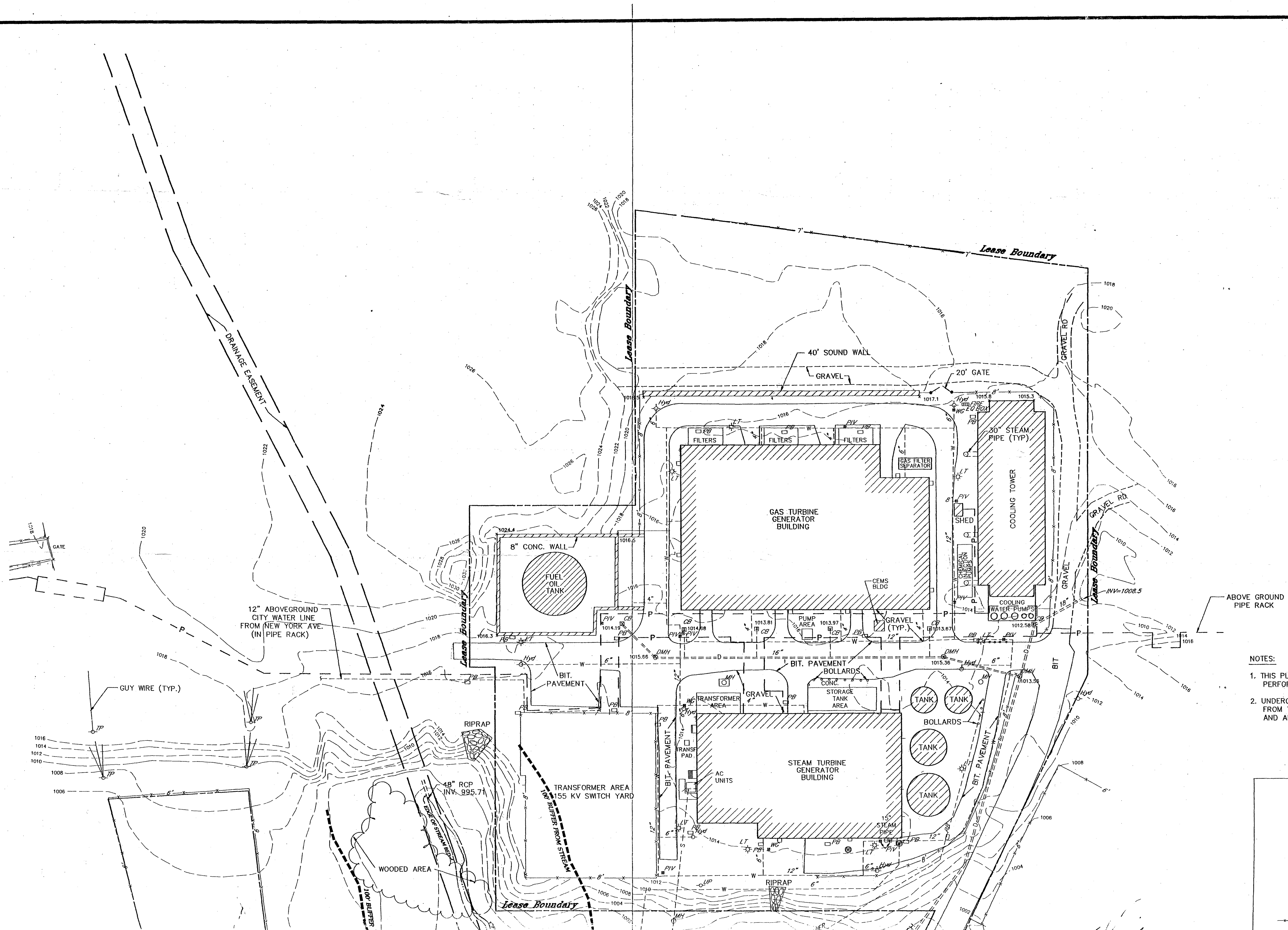
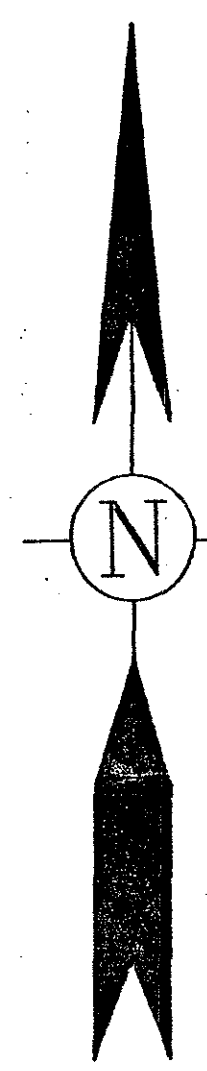

Table with 2 columns: REVISIONS, PRINTS TO

MADE BY J. L. Brooke, ISSUED May 4-51, APPROVALS, PITTSLD, 1251445, SHEET NO. 733A



12" ABOVEGROUND CITY WATER LINE FROM NEW YORK AVE. (IN PIPE RACK)

ABOVE GROUND PIPE RACK

NOTES:

1. THIS PLAN IS A RESULT OF SURVEY PERFORMED IN JULY, 1990.
2. UNDERGROUND UTILITIES ARE FROM THE BEST AVAILABLE DATA AND ARE NOT GUARANTEED

LEGEND	
	PULL BOX
	FIRE HYDR.
	POST INDIC.
	MANHOLE
	CATCH BAS.
	LIGHT POS.
	TRANSMISS.
	UTILITY PO.
	TEST WELL
	CHAIN LINK
	WATER PIPE

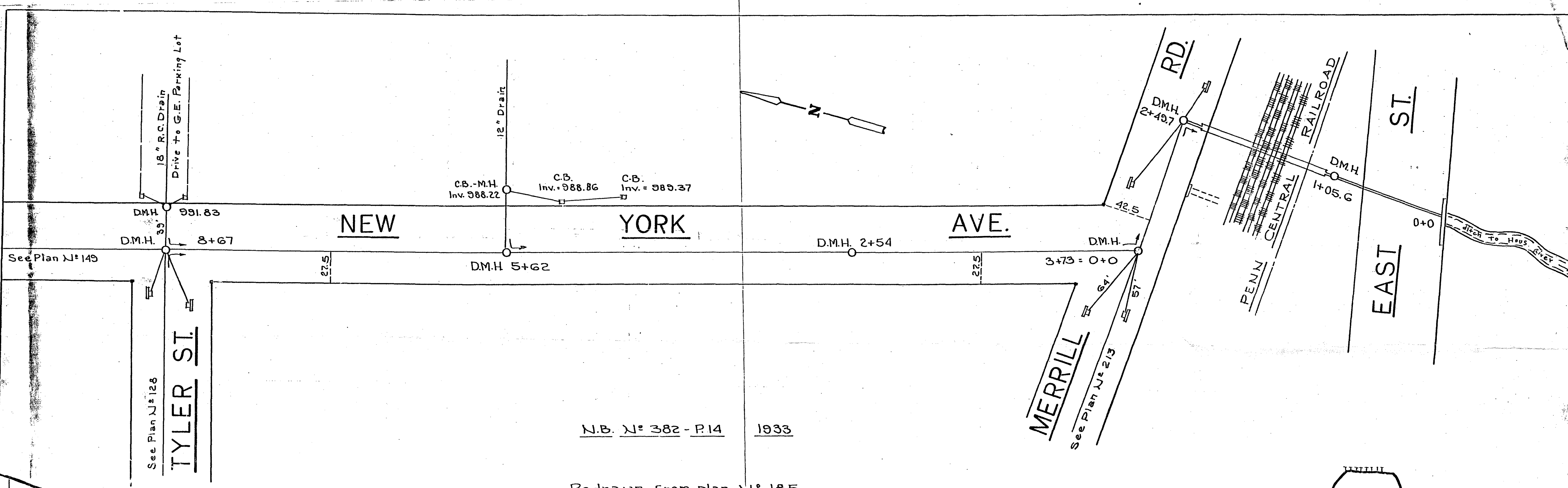

N.B. N° 382 - P.14 1933

Redrawn from plan N° 185

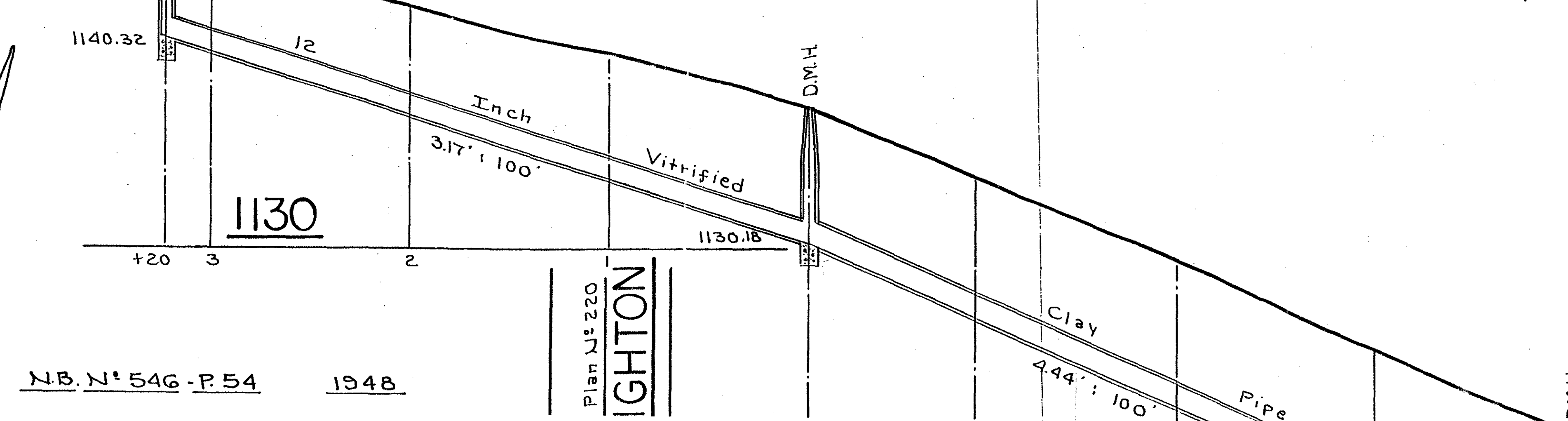
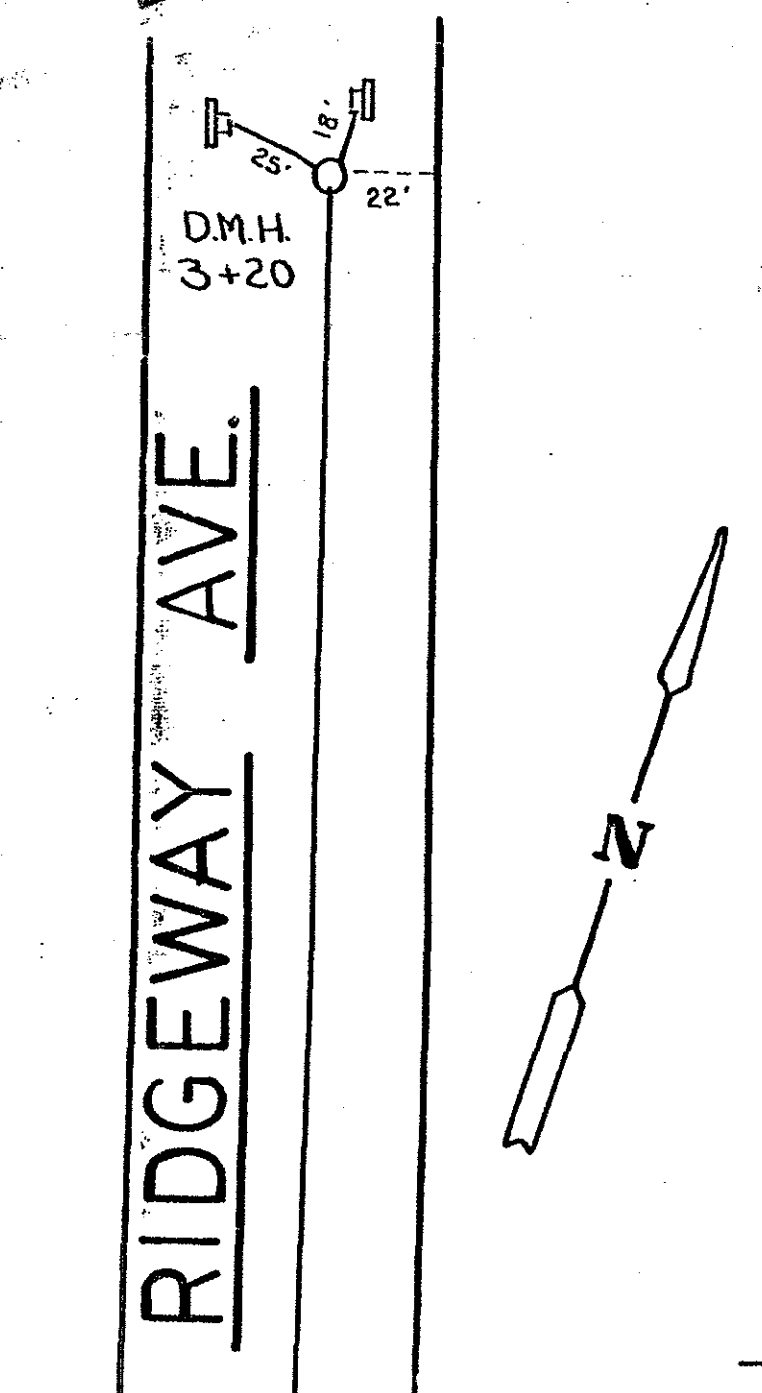
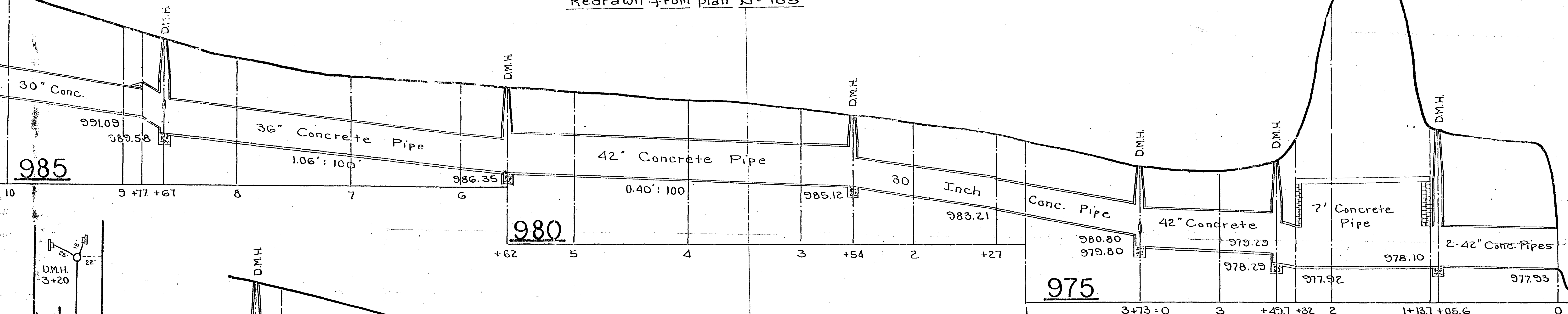

N.B. N° 546 - P.54 1948

Plan N° 220

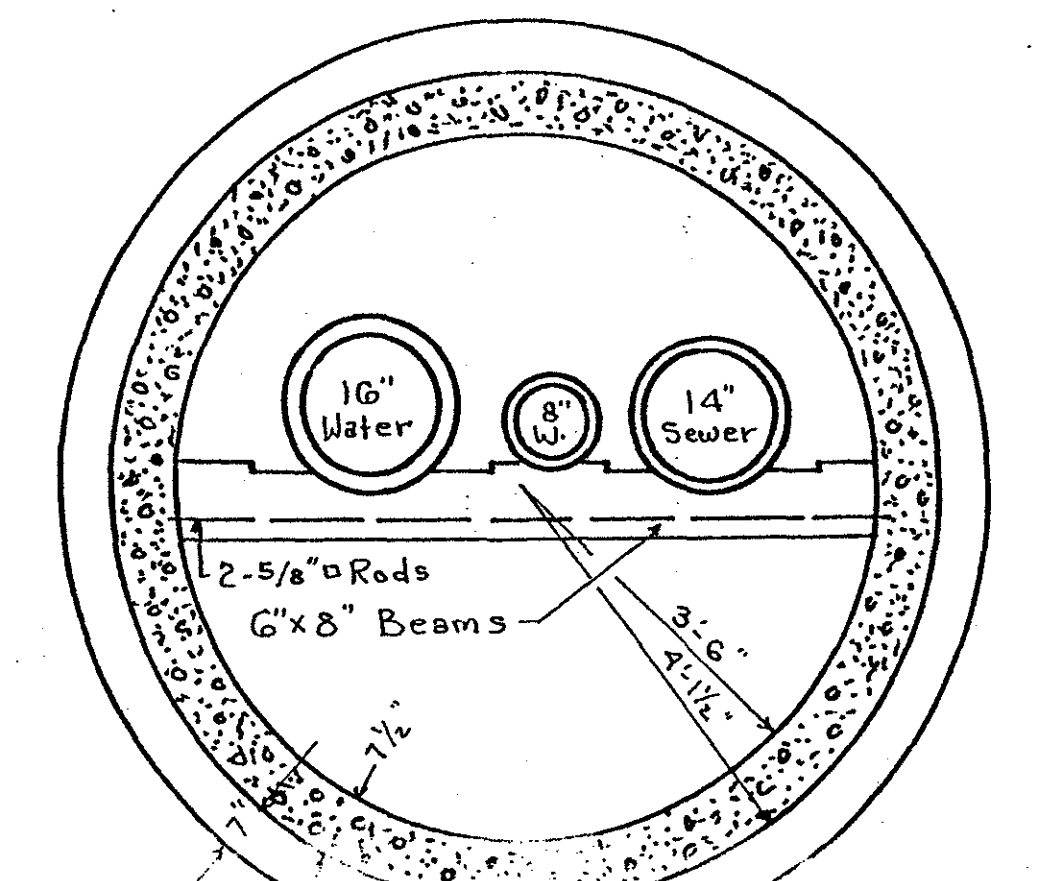

APPENDIX F
PITTSFIELD ZONING MAP

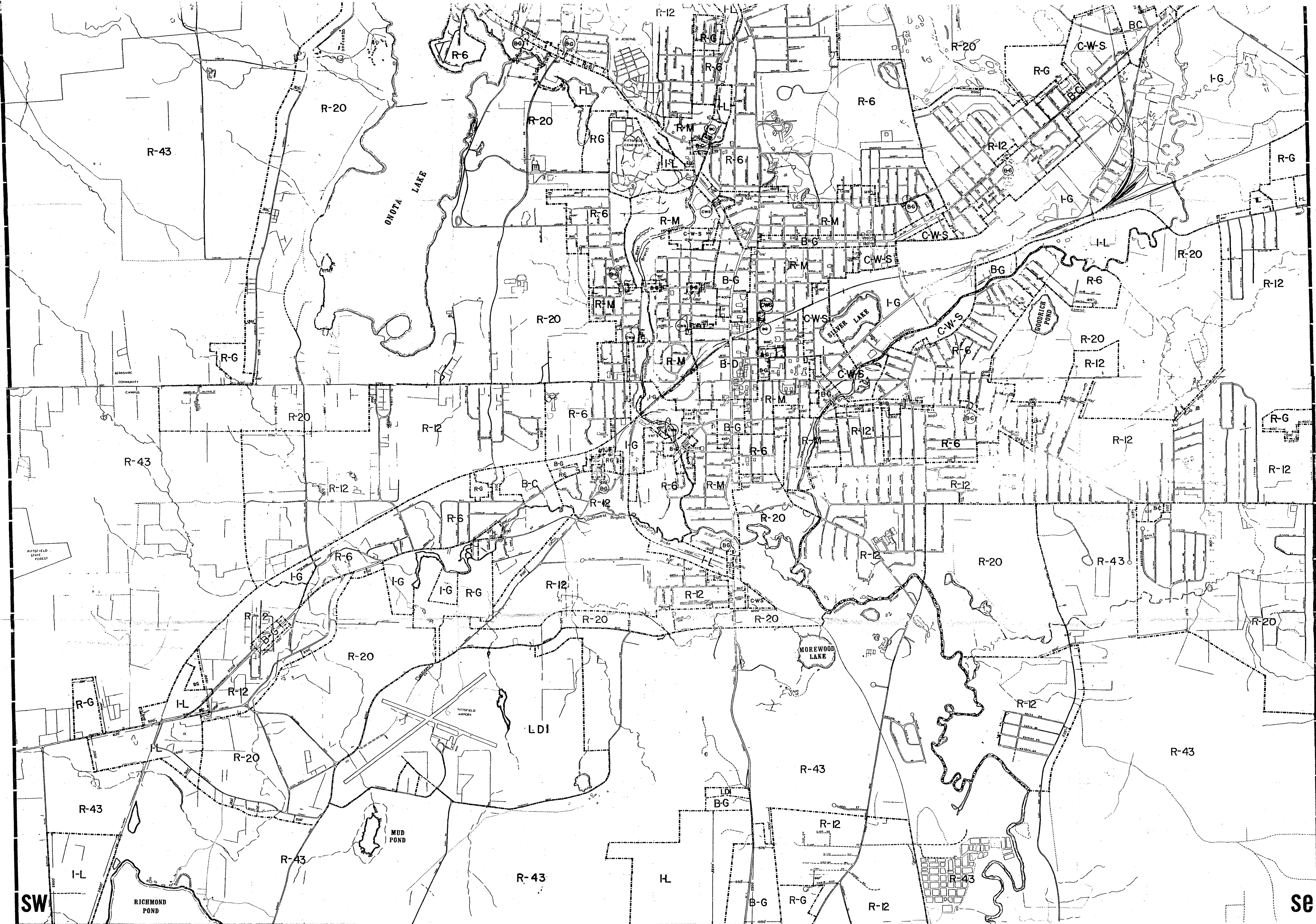

PREPARED BY
PITTSFIELD PLANNING BOARD
 BASE MAP BY
 Technical Planning Associates tpa

Scale: 1" = 600'
 Revisions: October 1984

PITTSFIELD ZONING MAP

ADOPTED: FEBRUARY 17, 1973
 THE CITY COUNCIL OF PITTSFIELD, MASSACHUSETTS

Richard H. Suter, MAYOR *Ann J. Gannon*, CITY CLERK *John J. Frason*, PRESIDENT OF CITY COUNCIL

LEGEND		
RESIDENCE DISTRICTS	BUSINESS DISTRICTS	INDUSTRIAL DISTRICTS
R-43 = Single Family 43,560 sq ft per lot	B-C = Grouped Business	I-L = Light Industrial
R-20 = Single Family 20,000 sq ft per lot	B-G = General Business	I-G = General Industrial
R-12 = Single Family 12,000 sq ft per lot	B-D = Downtown Business	SPECIAL DISTRICTS
R-6 = Single Family 6,000 sq ft per lot	C-W-S = Commercial, Warehousing and Storage	LDI = Limited Industrial
R-G = Garden Apartments		
R-M = Multi-Family		
Zone Boundary - - - - -		

APPENDIX G
GENERATOR ANNUAL REPORT

FOR OFFICE USE
DATE RECEIVED: ___/___/___

M.A.D. 0.0.2.08.4.0.9.3.
1989 Annual Report Page 1 of 21

PART I
STATUS CERTIFICATION

(A Part I response is REQUIRED by law from all recipients of this report)

You may use your mailing label for numbers 1, 2, 3, if correct. Your correct EPA Identification Number is on your mailing label and is the number you should be using on all of your manifests and correspondence to this office. EPA numbers begin with the letters M.A.D. unless the company is federally owned. You should also write in your number in the upper right hand corner of each page of this report you are completing.

1. INSTALLATION NAME: General Electric Company
(check if change from mailing label)

2. EPA IDENTIFICATION # M.A.D. 0.0.2.0.8.4.0.9.3.

3. a) INSTALLATION ADDRESS:

100 Woodlawn Avenue Pittsfield MA 01201
street city state zip

b) MAILING ADDRESS (if different from above):

street or box city state zip
(check if change from mailing label)

c) CONTACT PERSON G. Grant Bowman
(x check if change from mailing label)

d) TELEPHONE NUMBER (413) 494 - 2700 EXT: _____

4. DESCRIBE YOUR GENERATOR STATUS - Check the Appropriate Response: A or B

A1) x We are a Large Quantity Generator as described in the instructions and are submitting PARTS I-IV, a complete Generator Annual Report as required in the General Instructions.

A2) x We are also an On-Site Treatment, Storage or Disposal Facility and are also submitting Part V.

B) We are submitting Part I of the Annual Report (Status Certification) but are not subject to the entire report as described in the instructions for the following reason

check one number below:

1) We did not generate hazardous waste in the quantities described in the General Instructions but will retain our status as a Large Quantity Generator for future use.

2) We moved or closed our operation during 1989. Our new address is (include mailing address if different):

New EPA ID #, if applicable: M.A.
Did you previously notify us of this change? Yes No.

PART I (continued)

- 3) Our generator status has changed to the following as of the following date: ___/___/___.
Did you previously notify us of this status change? Yes No.

CHANGE OF STATUS CERTIFICATION

Hazardous Waste:

- No hazardous waste is generated.
- Very Small Quantity*, a maximum of 27 gallons per month.
- Small Quantity, between 27 and 265 gallons per month.

* Check if you need to register as a VSQG

Waste Oil

Did your company generate any waste oil during 1989?(yes or no)
If yes, what was the total quantity of waste oil generated for 1989

5. CERTIFICATION

I certify under penalty of law that I have personally examined and am familiar with the information submitted in the document and all attached documents, and that based on my inquiry of those individuals immediately responsible for obtaining the information, I believe that the submitted information is true, accurate, and complete, I am aware that there are significant penalties for submitting false information, including the possibility of fine and imprisonment.

In addition, I understand that any material supplied with this application will not be considered confidential unless I have specifically requested that such material be kept confidential and the Department has made a determination of confidentiality in accordance with 310 CMR 3.000, Regulations Governing Access for and Confidentiality of Department Records and files under the Hazardous Waste Management Act.

G. Grant Bowman
Authorized Signature of Owner/Operator

3-26-90
Date

G. Grant Bowman
Print Name

Manager-Environmental Engineering
Title

PART II
CROSS-PROGRAM INFORMATION

1. DOES YOUR INSTALLATION DISCHARGE PROCESS WASTEWATER? YES NO

Is it hazardous prior to processing? YES NO

If Yes, complete all that apply:

If no, DO NOT fill out this section of the report?

A) NPDES Permit # MA0003891

B) Groundwater Discharge Permit N/A

C) Do you discharge to a municipal sewer system: YES NO

If yes, name of municipal sewer system: City of Pittsfield

2. IS YOUR INSTALLATION REGISTERED WITH THE DIVISION OF AIR QUALITY CONTROL?

YES NO For verification contact your DEP regional office
Air Quality Control Branch.

3. HAZARDOUS WASTE TRANSPORTERS USED IN 1989.

Refer to your hazardous waste manifests for 1989 (not including waste oil) and list all transporters used during the year. Attach additional pages if necessary.

<u>NAME</u>	<u>EPA IDENTIFICATION #</u>
<u>GE Co., Pittsfield, MA</u>	<u>.M A .D .0 .0 .2 .0 .8 .4 .0 .9 .3 .</u>
<u>Clean Harbors, Kingston, NY</u>	<u>.M A .D .0 .3 .9 .3 .2 .2 .2 .5 .0 .</u>
<u>Chemical Waste Management</u>	<u>.I L .D .0 .9 .9 .2 .0 .2 .6 .8 .1 .</u>
<u>Hazmat Environmental Group</u>	<u>.N Y .D .9 .8 .0 .7 .6 .9 .9 .4 .7 .</u>
<u>CECOS Treatment Corp.</u>	<u>.C T .D .0 .0 .0 .6 .0 .4 .4 .8 .8 .</u>
<u>Buffalo Fuel Corp.</u>	<u>.N Y .D .0 .5 .1 .8 .0 .9 .9 .5 .2 .</u>
<u>Northeast Solvents Corp.</u>	<u>.M A .D .0 .0 .0 .6 .0 .4 .4 .4 .7 .</u>
<u>Mr. Frank, Inc.</u>	<u>I L D 0 6 9 5 0 6 1 6 0</u>
<u>Price Trucking Corp.</u>	<u>.N Y .D .0 .4 .6 .7 .6 .5 .5 .7 .4 .</u>
<u>Clean Harbors, Natick, MA</u>	<u>M A D 9 8 0 5 2 3 2 0 3</u>
<u>ENSCO</u>	<u>.A R .D .0 .6 .9 .7 .4 .8 .1 .9 .2 .</u>
<u>Service Canitaire</u>	<u>N Y D 9 8 0 7 6 2 1 4 0</u>
<u>Environmental Waste Resources</u>	<u>.C T .D .0 .7 .2 .1 .3 .8 .9 .6 .9 .</u>
<u>Technic's Inc.</u>	<u>R I D 0 0 1 2 0 0 2 5 2</u>
<u>S-J Transportation</u>	<u>.N J .D .0 .7 .1 .6 .2 .9 .9 .7 .6 .</u>
<u>Clean Berkshires, Inc.</u>	<u>M A D 9 8 2 5 4 5 2 0 4</u>

PART III
WASTE SUMMARY

Part III is required of all Large Quantity Generators. To complete you must reference all of your hazardous waste manifests for 1989 (not including waste oil). See Appendix I for instructions. You must complete a separate page for each facility to which you shipped waste. Reproduce blank pages as necessary.

1. NAME OF RECEIVING FACILITY: Clean Harbors of Braintree, MA
(if exported identify US point of departure)

2. FACILITY EPA IDENTIFICATION NUMBER: .M.A.D.0.5.3.4.5.2.6.3.7.

3. HAZARDOUS WASTE SHIPPED OFF SITE:

Instructions for the chart below are in Appendices I and II.

LINE #	A DESCRIPTION OF WASTE	B WASTE CODE	C TOTAL QUANTITY	D UNIT CODE	E HANDLING CODE
1	Ignitable-Liquids	D001	12925	G	S01, S02
2	Ignitable-Solids	D001	27.0	T	S01
3	Corrosive-Liquids	D002	24,035	G	S01, S02
4	Corrosive-Solids	D002	2.5	T	S01
5	Reactive-Liquids	D003	40	G	S01
6	Chrome-Liquids	D007	5112	G	S01, S02
7	Chrome-Solids	D007	.4	T	S01
8	Lead-Liquids	D008	2035	G	S01, S02
9	Lead-Solids	D008	2.3	T	S01
10	Halogenated-Liquids	F001	8470	G	T63
11	Halogenated-Solids	F001	.6	T	S01
12	Halogenated-Liquids	F002	10,230	G	S02, T63

PART III
WASTE SUMMARY

Part III is required of all Large Quantity Generators. To complete you must reference all of your hazardous waste manifests for 1989 (not including waste oil). See Appendix I for instructions. You must complete a separate page for each facility to which you shipped waste. Reproduce blank pages as necessary.

1. NAME OF RECEIVING FACILITY: Clean Harbors, Braintree, MA
(if exported identify US point of departure)

2. FACILITY EPA IDENTIFICATION NUMBER: .M.A.D. 0 5 3 4 5 2 6 3 7.

3. HAZARDOUS WASTE SHIPPED OFF SITE:

Instructions for the chart below are in Appendices I and II.

LINE #	A DESCRIPTION OF WASTE	B WASTE CODE	C TOTAL QUANTITY	D UNIT CODE	E HANDLING CODE
13	Halogenated-Solids	F002	.2	T	S01
14	Non-Halogenated-Lqds	F003	7150	G	S01
15	Non-Halogenated-Slds	F003	2.7	T	S01
16	Non-Halogenated-Lqds	F005	6270	G	S02, T63
17	Non-Halogenated-Slds	F005	43.5	T	S01
18	Aluminum Coat.-Lqds	F019	27,115	G	S02
19	Oil-Liquids	MA01	62,535	G	S01, S02
20	Oil-Solids	MA01	77.9	T	S01
21	PCB-Liquids	MA02	8098	G	S01
22	PCB-Solids	MA02	79.3	T	S01
23	Phenol-Liquids	U188	1620	G	S01, S02
24	Phenol-Solids	U188	1.3	T	S01

PART III
WASTE SUMMARY

Part III is required of all Large Quantity Generators. To complete you must reference all of your hazardous waste manifests for 1989 (not including waste oil). See Appendix I for instructions. You must complete a separate page for each facility to which you shipped waste. Reproduce blank pages as necessary.

1. NAME OF RECEIVING FACILITY: Clean Harbors, Natick, MA
(if exported identify US point of departure)
2. FACILITY EPA IDENTIFICATION NUMBER: M.A.D. 9.8.0.5.2.3.2.0.3.
3. HAZARDOUS WASTE SHIPPED OFF SITE:

Instructions for the chart below are in Appendices I and II.

LINE #	A DESCRIPTION OF WASTE	B WASTE CODE	C TOTAL QUANTITY	D UNIT CODE	E HANDLING CODE
1	Lab Pack-Liquids	*See below	14,781	G	S01
2	Lab Pack-Solids	*See below	2.0	T	S01
	*packaged lab chemicals of following codes:				
	D001, D002, D003, D005, D006, D009, F001				
	F003, F007, MA01, P030, U002, U003, U004				
	U007, U009, U019, U031, U034, U044, U051, U056				
	U057, U060, U080, U083, U112, U121, U122, U123,				
	U154, U159, U161, U162, U169, U173, U188, U196,				
	U211, U213, U220, U221, U223, U228, U239, U240				

PART IV
WASTE MINIMIZATION AND SOURCE REDUCTION

Part IV is required of all Large Quantity Generators. A separate Part IV must be completed for each type of waste which was reduced.

The uniform hazardous waste manifest requires all generators to certify, on Item 16, that they have a program in place to reduce, to the degree determined economically practical, the volume and toxicity of the waste generated.

Waste minimization means the reduction of hazardous waste that is generated or subsequently treated, stored or disposed. Waste minimization includes any source reduction or recycling activity undertaken by a generator that results in: (1) the reduction of total volume or quantity of hazardous waste; (2) the reduction of toxicity of hazardous waste; or (3) both, as long as the reduction is consistent with the goal of minimizing present and future threats to human health and the environment.

* Note-all hazardous waste generators should expect to receive an additional waste minimization form directly from EPA within the next month which must be returned to them directly when completed.

1. Check type of waste minimization activity below for each type of waste which was reduced:

<u>CODE</u>	<u>ACTIVITY</u>
<u> </u> 0	No Waste Minimization activity undertaken
<u> </u> x 1	Process equipment or technology modification/substitution
<u> </u> 2	Process procedure modification/substitution (includes closed loop recycling)
<u> </u> 3	Reformation or redesign of product
<u> </u> 4	Modification/substitution of input or raw material
<u> </u> x 5	Better housekeeping/better operating practices
<u> </u> 6	Waste stream segregation; includes oil & water separation; centrifugation
<u> </u> 7	Other, specify in Comments below

2. Quantity Prevented - Best Estimate

Enter the quantity of hazardous waste you believe was prevented or never generated due to the waste minimization project or activity conducted at the site.

- type of waste reduced (EPA four digit waste code): .M.A.0.2.

- amount of this waste reduced in 1989: 9,000 gal.

Briefly describe the project or activity that produced this reduction.
Attach additional page if necessary. Evaporation and distillation of machine coolants.

PART V
ON SITE TREATMENT ACTIVITY

Wastewater Treatment Units need to complete Section 1 parts a, b, and c. On Site Facilities need to complete Section 2, parts a, b, c, d, and e. See Appendices I and II for instructions. Reproduce blank pages if necessary.

1. Wastewater Treatment Unit Activity:

a. Description of waste treated: N/A

EPA waste code N/A.

b. Amount of waste entered in the treatment process in 1989. You may estimate this amount by multiplying the average amount per day by the number of operating work days in the calendar year:

N/A

c. Attach description of wastewater treatment process.

2. On Site Facility Activity: (See Appendices I and II for instructions) N/A

LINE #	A DESCRIPTION OF WASTE	B WASTE CODE	C TOTAL QUANTITY	D UNIT CODE	E HANDLING CODE

b. Most recent closure cost estimate: N/A

c. Most recent post-closure cost estimate: N/A

d. Attach summary of incidents when the contingency plan was implemented.

APPENDIX H
SOIL BORING AND WELL CONSTRUCTION LOGS

HILL 78
SOIL BORING AND WELL CONSTRUCTION LOGS

SAMPLE/CORE LOG

Boring/Well 78-1 Project/No. AY05502 Page 1 of 1
 Site Location Hill 78 Area, Pittsfield, MA Drilling Started 1-2-90 Drilling Completed 1-2-90
 Total Depth Drilled 23 feet Hole Diameter 6.65 inches Type of Sample/ Coring Device Split-spoon
 Length and Diameter of Coring Device (2' x 2") Sampling Interval 2 feet
 Land-Surface Elev. 1027.4 feet Surveyed Estimated Datum USGS 1929
 Drilling Fluid Used None Drilling Method Hollow-stem Auger
 Drilling Contractor Clean Berkshires, Inc. Driller Ed Helper George Ron
 Prepared By A. LaBarge Hammer Weight 140# Hammer Drop 30 inches

Sample/Core Depth (feet below land surface)		Core Recovery (feet)	Time/Hydraulic Pressure or Blows per 6 inches	SAMPLE ID	Sample/Core Description
From	To				
0	2	1.0	11-10-12-12	PH01B0002	SAND (75%) brown, medium to coarse; Gravel (15%); fine to medium, poorly sorted.
2	4	0.2	8-8-5-4	PH01B0204	SAND (50%) brown, medium; Gravel (50%) fine, well-sorted.
4	6	1.2	2-9-5-4	PH01B0406	SAND (85%) light-brown, fine, moist; Gravel (10%) fine, well-sorted; Abrupt change to black organic peat material with roots at base of spoon, ~ 5.8'.
6	8	0.7	2-1-2-5	PH01B0608	SAND (95%) light-brown, fine, moist; Gravel (5%) very fine.
8	10	1.6	5-5-4-5	PH01B0810	SAND (95%) brown-grey, fine, moist; Gravel (5%) fine.
10	12	1.8	8-10-7-12	PH01B1012	SAND (95%) light-brown to red-brown, moist, fine, includes roots and reeds; Gravel (5%) fine.
12	14	1.9	6-7-10-11	PH01B1214	SAND (90%) light-brown to grey, fine, moist; Gravel (10%) fine to medium, rounded to subangular.
14	16	1.8	7-9-10-8	PH01B1416	Same as above, wet.
16	18	1.9	15-20-13-15	PH01B1618	Same as above, wet.
18	20	2.0	18-41-36-40	PH01B1820	Same as above, wet.
20	22	0.8	25-31-100/R	PH01B2022	SAND (85%) red-brown, medium to coarse; Rock fragments (15%); refusal at ~ 22 feet
22	23				No recovery, pushing boulder; Augured to 23 feet
					TD = 23 feet.
					DTW = 9.5 feet.

SAMPLE/CORE LOG

Boring/Well 78-2 Project/No. AY05502 Page 1 of 1
 Site Location Hill 78 Area, Pittsfield, MA Drilling Started 1-4-90 Drilling Completed 1-4-90
 Total Depth Drilled 24 feet Hole Diameter 6.65 inches Type of Sample/ Coring Device Split-spoon
 Length and Diameter of Coring Device (2' x 2") Sampling Interval 2 feet
 Land-Surface Elev. 1034.9 feet Surveyed Estimated Datum USGS 1929
 Drilling Fluid Used None Drilling Method Hollow-stem Auger
 Drilling Contractor Clean Berkshires, Inc. Driller Ed Helper George Ron
 Prepared By A. LaBarge Hammer Weight 140# Hammer Drop 30 inches

Sample/Core Depth (feet below land surface)		Core Recovery (feet)	Time/Hydraulic Pressure or Blows per 6 inches	SAMPLE ID	Sample/Core Description
From	To				
0	2	0.9	7-7-6-11	PH02B0002	SAND (85%) dark-brown, medium, grading to light brown-grey, fine; Sandstone fragments (10%) white; grass and roots.
2	4	2.0	17-23-22-27	PH02B0204	SAND (100%) light-brown, fine, dry.
4	6	1.9	10-13-31-34	PH02B0406	Same as above, slightly dryer, very tight.
6	8	1.6	25-31-46-60	PH02B0608	Same, trace gravel, moist, very tight.
8	10	1.7	6-7-33-40	PH02B0810	Same sand as above, trace black staining, very tight.
10	12	1.2	34-60/R	PH02B1012	SAND as above (90%); Sandstone fragments (10%), white; refusal at 11 feet, augered to 12 feet.
12	14	1.7	15-31-50-60	PH02B1214	Same as above, moist at top, dry at bottom.
14	16	1.8	14-28-47-39	PH02B1416	SAND (90%) dark-brown, fine, moist at top; grey-brown, fine, dry at base; Sandstone fragments (10%) orange, white.
16	18	1.2	30-60/R	PH02B1618	SAND (95%) grey-brown, fine, dry, Very tight, Refusal at ~ 17 feet, augered to 18 feet.
18	20	1.9	5-16-35-42	PH02B1820	SAND (100%) dark-brown, fine, moist at top; grey-brown, fine, dry at base.
20	22	2.0	29-60-55-54	PH02B2022	SAND (100%) grey-brown, fine at top; grading into grey-brown to white, medium to coarse at base, wet.
22	24	2.0	12-12-29-59	PH02B2224	SAND (95%) wet, coarse, white to grey, grading to dry fine, gray in shoe; Gravel (5%) fine and angular in shoe. DTW = 8 feet. TD = 24 feet.

SAMPLE/CORE LOG

Boring/Well 78-3 Project/No. AY05502

Site Location Hill 78 Area, Pittsfield, MA Drilling Started 1-7-90 Drilling Completed 1-7-90

Total Depth Drilled 25 feet Hole Diameter 6.65 inches Type of Sample/ Coring Device Split-spoon

Length and Diameter of Coring Device (2' x 2") Sampling Interval 2 feet
USGS 1929

Land-Surface Elev. 1008.1 feet Surveyed Estimated Datum Hollow-stem Auger

Drilling Fluid Used None Drilling Method Hollow-stem Auger

Drilling Contractor Clean Berkshires, Inc. Driller George Helper Ron John

Prepared By A. Labarge Hammer Weight 140# Hammer Drop 30 inches

Sample/Core Depth (feet below land surface)		Core Recovery (feet)	Time/Hydraulic Pressure or Blows per 6 inches	SAMPLE ID	Sample/Core Description
From	To				
0	2	1.1	19-17-13-10	PH03B0002	SAND (80%) red-brown, medium to coarse, dry; Gravel (20%) medium, well-sorted.
2	4	1.2	8-7-6-5	PH03B0204	SAND (85%) red-gold, coarse dry; Gravel (15%) medium-size, well-sorted, subrounded.
4	6	0.8	4-5-7-7	PH030406	SAND (90%) brown-gold, coarse, dry; Gravel (10%) medium, well-sorted, subrounded.
6	8	1.1	6-5-3-7	PH02B0608	SAND (90%) gold-brown, medium to coarse; Gravel (10%) fine to medium, well-sorted, subrounded.
8	10	1.1	6-4-3-4	PH03B0810	SAND (90%) gold-brown, coarse; Gravel (10%) fine to coarse poorly-sorted, subrounded.
10	12	0.7	4-5-6-6	PH03B1012	SAND (80%) gold-brown, coarse; Gravel (20%) fine to coarse poorly-sorted, angular to rounded.
12	14	0.4	5-4-5-60/R	PH03B1214	SAND (70%) gold-brown, coarse; Gravel (20%) fine to coarse, angular to subrounded; Abrupt change to very fine Sand (10%) olive-brown, moist, at 13.5 ft.; Refusal at 13.7 ft.
14	16	1.6	7-9-20-23	PH03B1416	SAND (95%) very fine, olive-brown; Gravel (5%) very fine; white, medium to coarse at base, wet.
16	18	1.2	8-20-21-25	PH03B1618	SAND (100%) Fine to Medium, Light Brown, wet; trace fine gravel.
18	20	1.2	13-18-32-33	PH03B1820	Same as above, wet.

SAMPLE/CORE LOG

Boring/Well 78-4 Project/No. AY05502 Page 1 of 2

Site Location Hill 78 Area, Pittsfield, MA Drilling Started 1-8-91 Drilling Completed 1-8-91

Total Depth Drilled 22 feet Hole Diameter 6.65 inches Type of Sample/
Coring Device split-spoon

Length and Diameter of Coring Device (2' x 2") Sampling Interval 2 feet

Land-Surface Elev. 999.5 feet Surveyed Estimated Datum USGS 1929

Drilling Fluid Used None Drilling Method Hollow-stem Auger

Drilling Contractor Clean Berkshires, Inc. Driller Ed Helper George Ron

Prepared By A. LaBarge Hammer Weight 140# Hammer Drop 30 inches

Sample/Core Depth (feet below land surface)		Core Recovery (feet)	Time/Hydraulic Pressure or Blows per 6 inches	SAMPLE ID	Sample/Core Description
From	To				
0	2	1.8	13-13-14-14	PH040002	SAND (70%) dark-brown, fine; Gravel (20%) fine to coarse, angular; Fill material (10%), paper, cellophane; Some organic material, bark, roots, reeds.
2	4	1.7	14-23-18-20	PH0480204	SAND (75%) dark-brown to olive-brown, fine to coarse; Silt (15%) olive-grey, dry, fine-grain; Gravel (10%) fine to coarse. No fill material.
4	6	1.9	6-8-8-9	PH0480406	SAND (95%) Gold-brown, fine, to dark-brown, medium; slight black stain, does not appear to be oil; Gravel (5%) fine to medium, angular.
6	8	2.0	13-14-16-21	PH0480608	SAND (95%) red-gold-brown, fine to medium, trace olive colored fine sand; Gravel (5%) fine, angular; Moist at top.
8	10	1.9	7-9-9-12	PH0480810	SAND (95%) red-brown, medium to coarse; Gravel (5%) fine to medium, subrounded to subangular; Trace fine olive-brown sand, moist.
10	12	1.8	9-11-6-8	PH0481012	SAND (90%) red-gold-brown, coarse, moist at bottom; Gravel (10%) fine to coarse, poorly sorted, moist.
12	14	2.0	5-6-7-12	PH0481214	SAND (90%) fine, Dark brown at top, coarse in middle grading to fine again at base; Gravel (10%) fine to medium, subangular, wet.
14	16	1.1	6-5-14-16	PH0481416	SAND (90%) coarse, dark brown at base, thin 2" Fine Sand Layer at top, wet; Gravel (10%) fine to medium

SAMPLE/CORE LOG

Boring/Well 78-5 Project/No. AY05502 Page 1 of 1

Site Location HILL 78 Area, Pittsfield, MA Drilling Started 1-9-91 Drilling Completed 1-9-91

Total Depth Drilled 17 feet Hole Diameter 6.65 inches Type of Sample/
Coring Device Split-spoon

Length and Diameter of Coring Device (2' x 2") Sampling Interval 2 feet

Land-Surface Elev. 997.8 feet Surveyed Estimated Datum usgs 1929

Drilling Fluid Used None Drilling Method Hollow-stem Auger

Drilling Contractor Clean Berkshires, Inc. Driller Ed Helper George Ron

Prepared By A. LaBarge Hammer Weight 140# Hammer Drop 30 inches

Sample/Core Depth (feet below land surface)		Core Recovery (feet)	Time/Hydraulic Pressure or Blows per 6 inches	SAMPLE ID	Sample/Core Description
From	To				
0	2	1.2	11-10-13-14	PH05B0002	SAND (80%) red to brown, coarse to medium; Rock fragments (20%) white, dry, trace gravel.
2	4	1.0	13-24-14-13	PH05B0204	SAND (95%) red-brown, coarse, moist at 1.5 feet; Gravel (5%), fine to medium.
4	6	1.2	4-3-22-17	PH05B0406	SAND (95%) red-brown, coarse grading to olive-brown, medium; Gravel (5%) fine to medium, angular, wet.
6	8	1.0	9-10-13-13	PH05B0608	SAND (95%) olive-brown, fine to medium, wet; Gravel (5%) fine, angular, sorted.
8	10	0.7	60-60/R	PH05B0310	SAND (95%) red-brown, coarse, wet; Gravel (5%) fine, angular.
10	12	1.1	41-27-26-22	PH05B1012	SAND (95%) olive-brown, fine to medium, moist at top, dryer on bottom; Gravel (5%) fine, angular.
12	14	2.0	11-14-25-24	PH05B1214	SAND (90%), same as above, wet; Schist fragments (10%) broken, shiny surfaces.
14	15	2.0	15-42-11-7	PH05B1416	SAND (95%) olive-brown, fine to coarse; Gravel (5%) fine coarse to wet.
16	17	1.0	6-5-	PH05B1617	Same as above TD = 17 feet. DTW = 5 feet.

SAMPLE/CORE LOG

Boring/Well 78-6 Project/No. AY05502 Page 1 of 1

Site Location Hill 78 Area, Pittsfield, MA Drilling Started 1-3-91 Drilling Completed 1-3-91

Total Depth Drilled 18 feet Hole Diameter 6.65 inches Type of Sample/ Coring Device Split-spoon

Length and Diameter of Coring Device (2' x 2") Sampling Interval 2 feet

Land-Surface Elev. 1013.1 feet Surveyed Estimated Datum usgs 1929

Drilling Fluid Used None Drilling Method Hollow-stem Auger

Drilling Contractor Clean Berkshires, Inc. Driller Ed Helper George Ron

Prepared By A. LaBarge Hammer Weight 140# Hammer Drop 30 inches

Sample/Core Depth (feet below land surface)		Core Recovery (feet)	Time/Hydraulic Pressure or Blows per 6 inches	SAMPLE ID	Sample/Core Description
From	To				
0	2	0.5	4-6-5-5	PH068002	SAND (80%) brown, fine, dry; Grass, roots (15%) top humus layer; Gravel (5%) very fine, rounded.
2	4	0.2	4-3-2-7	PH0680204	SAND (90%) light brown to brown, fine to medium, dry; Gravel (10%) fine, subangular.
4	6	0.8	7-8-5-6	PH0680406	Same as above.
6	8	1.3	6-10-6-7	PH0680608	SAND (95%) light brown to reddish brown, fine, moist; Gravel (5%) fine, subrounded. Trace of plastic material.
8	10	1.5	2-1-3-5	PH0680310	SAND (95%) brown to light grey, fine, wet; Gravel (5%) fine to medium, subrounded.
10	12	1.9	11-11-6-5	PH0681012	SAND (95%) light-grey, fine, wet; Gravel (5%) fine, rounded.
12	14	1.8	3-7-13-16	PH0681214	SAND (50%) light-grey, fine, wet; Abrupt change to black peat (30%), natural organic material at 13 feet, with roots; SAND (20%) grey, fine, dry at base, tight.
14	16	1.6	5-6-10-16	PH0681416	SAND (95%) light-grey to brown, fine, moist; Trace silt, grey.
16	18	2.0	21-20-23-20	PH0681618	SAND (85%) light-grey, fine at top, coarsening and yellow-brown at base; Gravel (15%) fine st top, coarse at base, wet.
					Bottom of boring TD = 18 feet
					DTW = 7.5

SAMPLE/CORE LOG

Boring/Well 78-7 Project/No. AY05502 Page 1 of 2

Site Location Hill 78 Area, Pittsfield, MA Drilling Started 1-10-91 Drilling Completed 1-10-91

Total Depth Drilled 28 feet Hole Diameter 6.65 inches Type of Sample/
Coring Device Split-spoon

Length and Diameter of Coring Device (2' x 2") Sampling Interval 2 feet

Land-Surface Elev. 1019.0 feet Surveyed Estimated Datum usgs 1929

Drilling Fluid Used None Drilling Method Hollow-stem Auger

Drilling Contractor Clean Bekishires, Inc. Driller Ed Helper George Ron

Prepared By A. LaBarge Hammer Weight 140# Hammer Drop 30 inches

Sample/Core Depth (feet below land surface)		Core Recovery (feet)	Time/Hydraulic Pressure or Blows per 6 inches	SAMPLE ID	Sample/Core Description
From	To				
0	2	1.9	25-25-29-21	PH07B0002	Sand (60%) dark-brown, fine grain at top, dry, light-brown, medium grain in middle; Brick (30%) bottom 5 inches; Gravel (10%) fine to coarse, angular to subangular.
2	4	0.5	27-17-17-16	PH07B0204	Sand (60%) olive-brown, to brown, medium-grain, dry; Brick (10%) at top of spoon; Gravel (30%) fine to very coarse, subrounded to subangular.
4	6	1.1	20-8-11-13	PH070406	Sand (90%) medium-brown to dark-brown, medium-grain, dry; Gravel (10%) fine to medium, angular to subangular, trace brick.
6	8	0.7	7-8-11-10	PH070608	Sand (75%) brown with yellow Sand layer, medium; Gravel (20%), fine to coarse, angular; Rock fragments(5%) large cobble in shoe
8	10	0.8	20-16-7-5	PH070810	Sand (90%) medium to dark brown, medium, moist; Gravel (10%) fine to medium, sorted.
10	12	0.7	13-20-13-9	PH07B1012	Sand (75%) medium-brown, fine, moist at top, roots and organic material; red-brown medium-grain at base; Gravel (25%) fine to coarse, angular, poorly sorted.
12	14	0.7	10-12-12-6	PH07B1214	Sand (90%) red-brown, to light-brown, medium to fine; Gravel (10%) fine to medium, angular; slightly moist at top, dry at bottom
14	16	1.2	5-10-15-22	PH07B1416	Sand (80%) medium-brown, fine, moist at top, red-brown, medium at base, dry at base; gravel (15%) fine to medium.

SAMPLE/CORE LOG (Cont.d)

Boring/Well 78-7

Page 2 of 2

Prepared By A. LaBarge

Sample/Core Depth (feet below land surface)		Core Recovery (feet)	Time/Hydraulic Pressure or Blows per 6 inches	SAMPLE ID	Sample/Core Description
From	To				
14	16	1.2	5-10-15-22	PH07B1416	angular; Coal fragments (5%) crushed.
16	18	1.9	24-13-17-14	PH07B1618	Sand (95%) olive-brown, fine-grain, moist, very tight; Gravel (5%), fine, angular.
18	20	1.0	12-11-10-15	PH07B1820	Same as above, tight, moist to wet.
20	22	2.0	8-18-18-19	PH07B2022	SAND (95%) olive-brown, fine to medium, not as tight, wet; Gravel (5%) fine, angular.
22	24	2.0	12-60/R	PH07B2224	Sand as above, wet, very tight at base. Refusal at ~ 23 feet augered to 24 feet.
24	26	1.0	13-28-19-18	PH07B2426	SAND (50%) as above wet; white sandstone fragments (45%) crushed; Gravel (5%) fine, angular.
26	28	2.0	4-19-22-14	PH07B2628	SAND (80%) olive-brown, fine to medium, tight at base, wet; Gravel (20%) fine to medium, angular. TD = 28 feet. DTW = 19 feet.

WELL CONSTRUCTION LOG (UNCONSOLIDATED)

Project AY05502 Well 78-1

Town/City Pittsfield

County Berkshire State MA

Permit No. _____

Land-Surface Elevation _____
and Datum 1027.4 feet Surveyed
USGS 1929 Estimated

Installation Date(s) 1-2-91

Drilling Method Hollow-stem Auger

Drilling Contractor Clean Berkshires, Inc.

Drilling Fluid None

Development Technique(s) and Date(s)

Centrifugal Pump 1-14-91

Fluid Loss During Drilling None gallons

Water Removed During Development 70 gallons

Static Depth to Water 9.50 feet below M.P.

Pumping Depth to Water _____ feet below M.P.

Pumping Duration _____ hours

Yield _____ gpm Date 1-14-91

Specific Capacity _____ gpm/ft

Well Purpose Groundwater Monitoring Well

Remarks Recovery slow, 26% after 8 min.
DTW = 12 feet before development.

Prepared by A. LaBarge

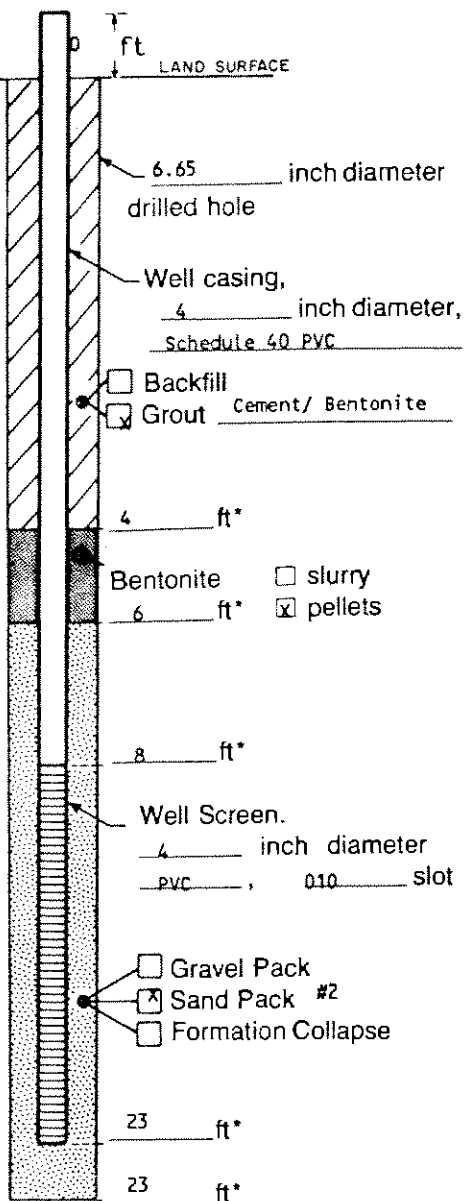

Measuring Point is
Top of Well Casing
Unless Otherwise Noted.

*Depth Below Land Surface

WELL CONSTRUCTION LOG
(UNCONSOLIDATED)

Project AY05502 Well 78-2

Town/City Pittsfield

County Berkshire State MA

Permit No. _____

Land-Surface Elevation and Datum 1034.9 feet Surveyed
USGS 1929 Estimated

Installation Date(s) 1-4-91

Drilling Method Hollow-stem Auger

Drilling Contractor Clean Berkshires, Inc.

Drilling Fluid None

Development Technique(s) and Date(s)
Centrifugal Pump 1-15-91

Fluid Loss During Drilling None gallons

Water Removed During Development 65 gallons

Static Depth to Water 6.98 feet below M.P.

Pumping Depth to Water _____ feet below M.P.

Pumping Duration _____ hours

Yield _____ gpm Date 1-15-91

Specific Capacity _____ gpm/ft

Well Purpose Groundwater Monitoring Well

Remarks _____

slow recovery, 27% after 10 min.

DTW = 8 feet before development.

Prepared by A. LaBarge

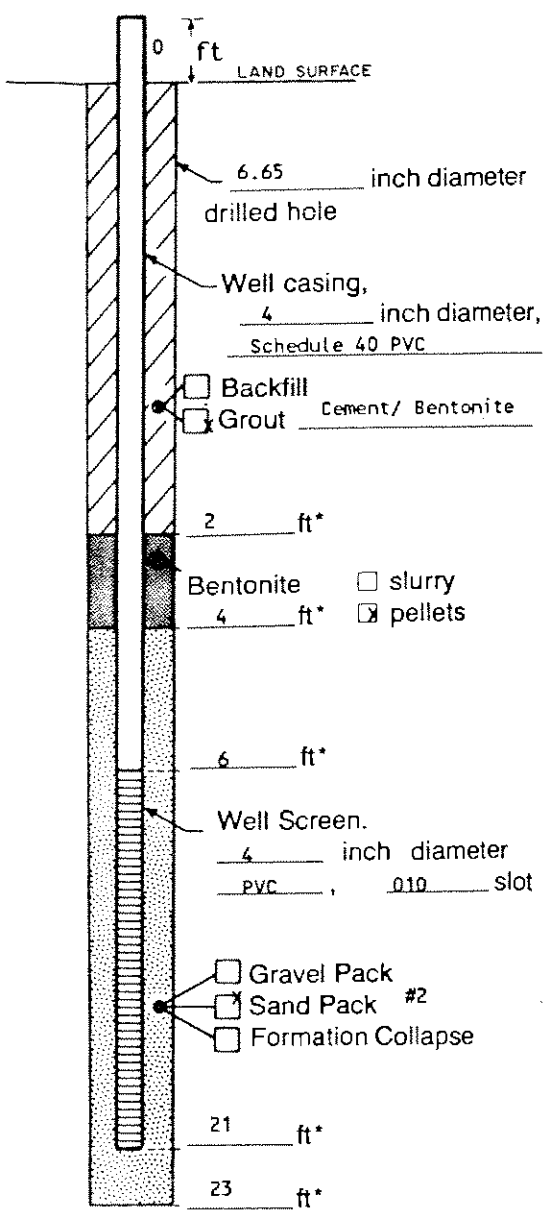

Measuring Point is
Top of Well Casing
Unless Otherwise Noted.

*Depth Below Land Surface

WELL CONSTRUCTION LOG
(UNCONSOLIDATED)

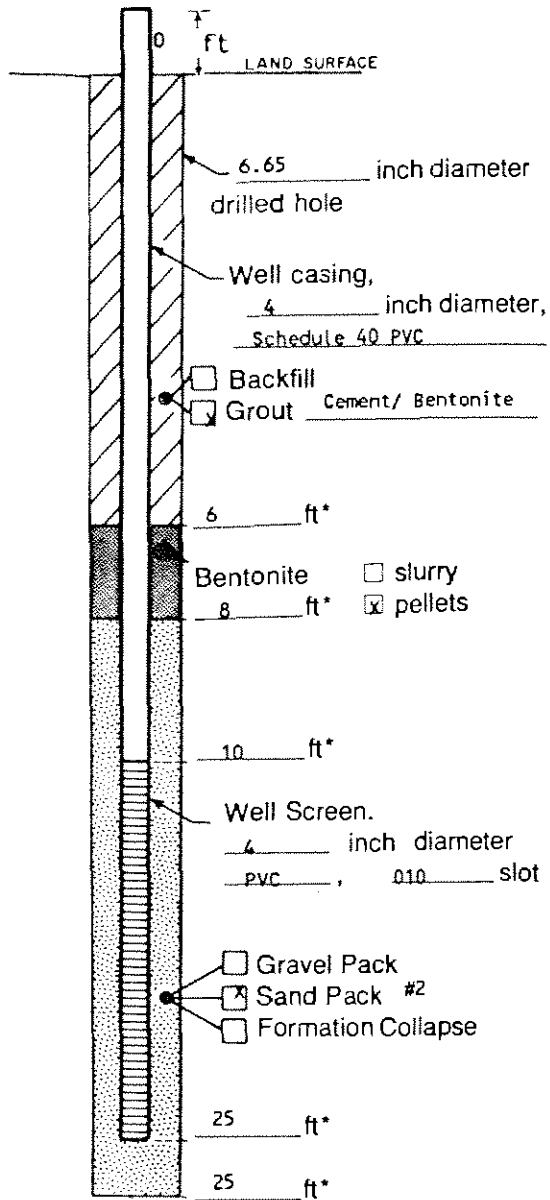

Measuring Point is
Top of Well Casing
Unless Otherwise Noted.

*Depth Below Land Surface

Project AY05502 Well 78-3

Town/City Pittsfield

County Berkshire State MA

Permit No. _____

Land-Surface Elevation
and Datum 1008.1 feet Surveyed
USGS 1929 Estimated

Installation Date(s) 1-7-91

Drilling Method Hollow-stem Auger

Drilling Contractor Clean Berkshires, Inc.

Drilling Fluid None

Development Technique(s) and Date(s)

Centrifugal Pump 1-15-91

Centrifugal Pump 1-16-91

Fluid Loss During Drilling None gallons

Water Removed During Development 75 gallons

Static Depth to Water 16.39 feet below M.P.

Pumping Depth to Water _____ feet below M.P.

Pumping Duration _____ hours

Yield _____ gpm Date 1-15-91

Specific Capacity _____ gpm/ft

Well Purpose Groundwater Monitoring Well

Remarks _____

Recovery - 75% after 10 min.

DTW = 17 feet before development.

Prepared by A. LaBarge

WELL CONSTRUCTION LOG
(UNCONSOLIDATED)

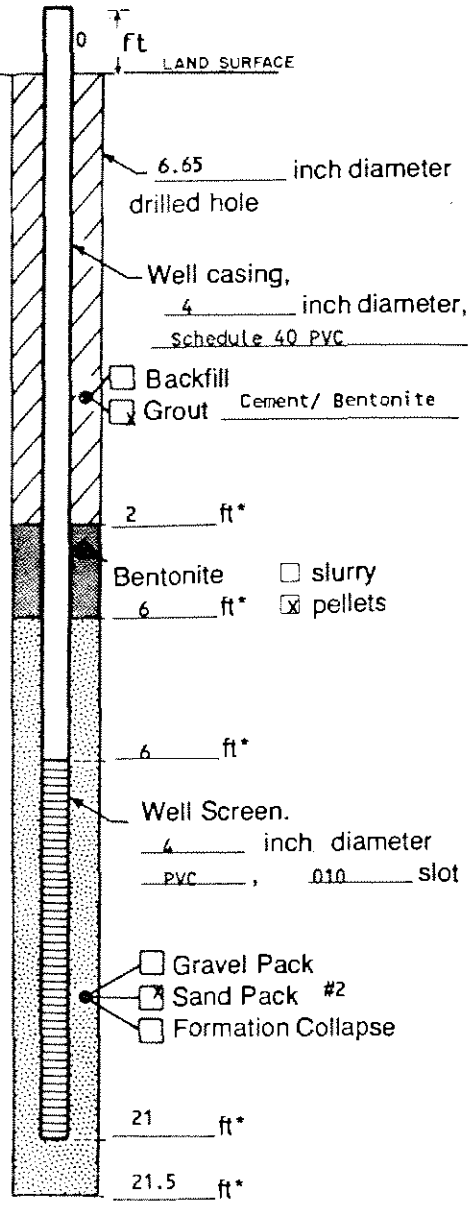

Measuring Point is
Top of Well Casing
Unless Otherwise Noted.

*Depth Below Land Surface

Project AY05502 Well 78-4

Town/City Pittsfield

County Berkshire State MA

Permit No. _____

Land-Surface Elevation
and Datum 999.5 feet Surveyed
USGS 1929 Estimated

Installation Date(s) 1-8-91

Drilling Method Hollow-stem Auger

Drilling Contractor Clean Berkshires, Inc.

Drilling Fluid None

Development Technique(s) and Date(s)
Centrifugal Pump 1-16-91

Fluid Loss During Drilling None gallons

Water Removed During Development 135 gallons

Static Depth to Water 12.12 feet below M.P.

Pumping Depth to Water _____ feet below M.P.

Pumping Duration _____ hours

Yield _____ gpm Date 1-16-91

Specific Capacity _____ gpm/ft

Well Purpose Groundwater Monitoring Well

Remarks _____

Recovery - 95% after 5 min..

DTW = 12 feet before development.

Prepared by A. LaBarge

WELL CONSTRUCTION LOG (UNCONSOLIDATED)

Project AY05502 Well 78-5

Town/City Pittsfield

County Berkshire State MA

Permit No. _____

Land-Surface Elevation and Datum 997.8 feet Surveyed
USGS 1929 Estimated

Installation Date(s) 1-9-91

Drilling Method Hollow-stem Auger

Drilling Contractor Clean Berkshires, Inc.

Drilling Fluid None

Development Technique(s) and Date(s)
Centrifugal Pump 1-16-91
Centrifugal Pump 1-21-91

Fluid Loss During Drilling None gallons

Water Removed During Development 90 gallons

Static Depth to Water 3.67 feet below M.P.

Pumping Depth to Water _____ feet below M.P.

Pumping Duration _____ hours

Yield _____ gpm Date 1-16-91

Specific Capacity _____ gpm/ft

Well Purpose Groundwater Monitoring Well

Remarks
Recovery 22% after 10 min.
DTW = 5 feet before development.

Prepared by A. LaBarge

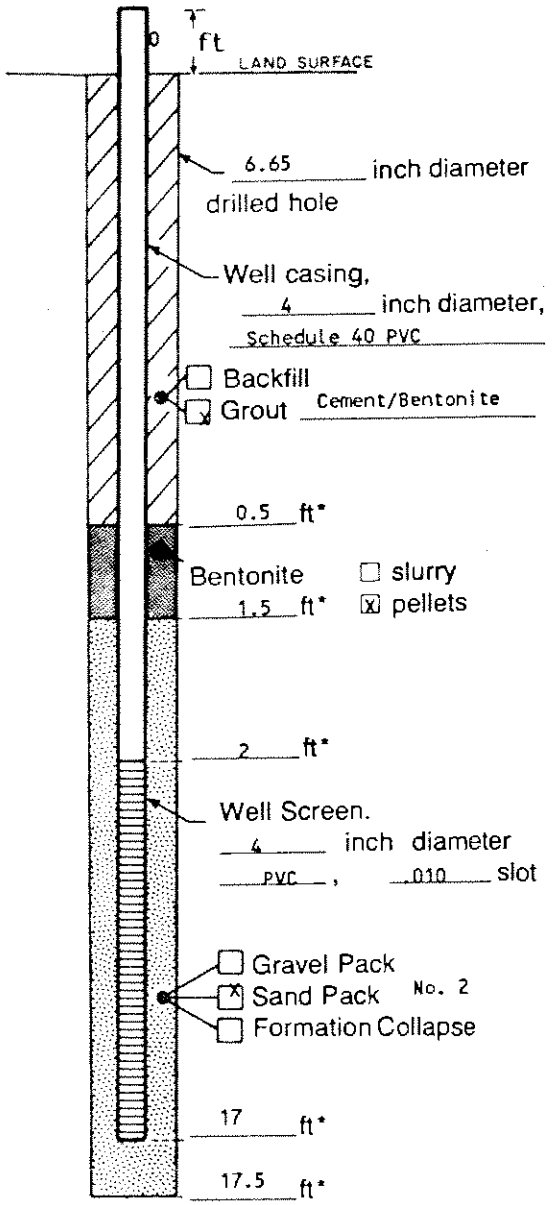

Measuring Point is
Top of Well Casing
Unless Otherwise Noted.

*Depth Below Land Surface

WELL CONSTRUCTION LOG
(UNCONSOLIDATED)

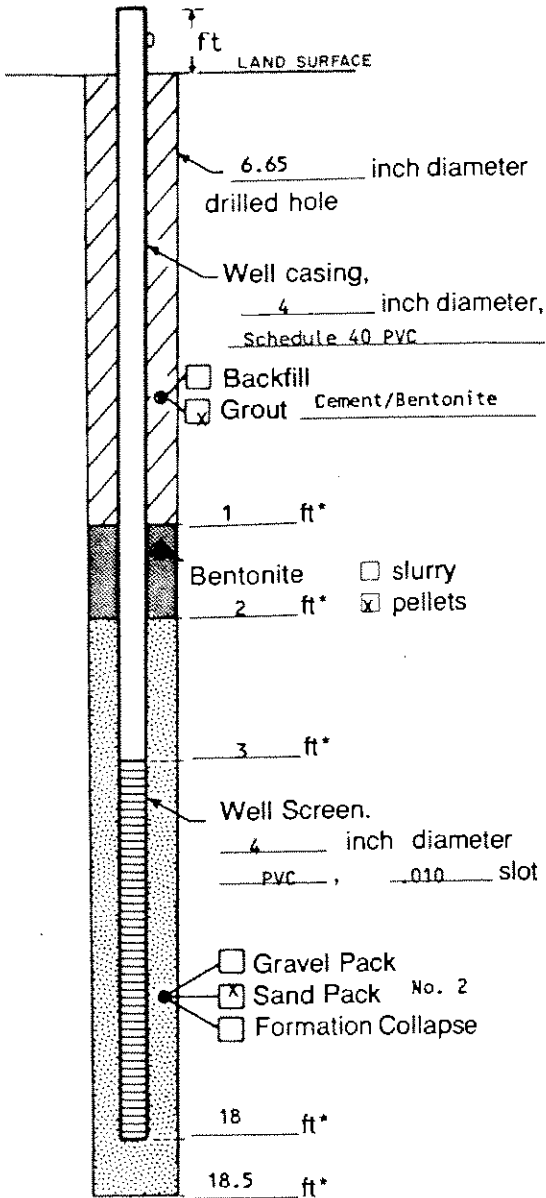

Measuring Point is
Top of Well Casing
Unless Otherwise Noted.

*Depth Below Land Surface

Project AY05502 Well 78-6

Town/City Pittsfield

County Berkshire State MA

Permit No. _____

Land-Surface Elevation _____
and Datum 1013.1 feet Surveyed
USGS 1929 Estimated

Installation Date(s) 1-3-91

Drilling Method Hollow-stem Auger

Drilling Contractor Clean Berkshires, Inc.

Drilling Fluid None

Development Technique(s) and Date(s)

Centrifugal Pump 1-14-91

Centrifugal Pump 1-18-91

Fluid Loss During Drilling None gallons

Water Removed During Development 210 gallons

Static Depth to Water 7.05 feet below M.P.

Pumping Depth to Water _____ feet below M.P.

Pumping Duration _____ hours

Yield _____ gpm Date 1-14-91

Specific Capacity _____ gpm/ft

Well Purpose Groundwater Monitoring Well

Remarks _____

Recovery 87% after 10 min.

DTW = 7 feet before development.

Prepared by A. LaBarge

WELL CONSTRUCTION LOG
(UNCONSOLIDATED)

Project AY05502 Well 78-7

Town/City Pittsfield

County Berkshire State MA

Permit No. _____

Land-Surface Elevation and Datum 1019.0 feet Surveyed
USGS 1929 Estimated

Installation Date(s) 1-10-91

Drilling Method Hollow-stem Auger

Drilling Contractor Clean Berkshires, Inc.

Drilling Fluid None

Development Technique(s) and Date(s)

Centrifugal Pump 1-18-91

Centrifugal pump 1-21-91

Fluid Loss During Drilling None gallons

Water Removed During Development 120 gallons

Static Depth to Water 16.65 feet below M.P.

Pumping Depth to Water _____ feet below M.P.

Pumping Duration _____ hours

Yield _____ gpm Date 1-18-91

Specific Capacity _____ gpm/ft

Well Purpose Groundwater Monitoring Well

Remarks _____

Recovery 15% after 10 min.

DTW = 19 feet before development.

Prepared by A. LaBarge

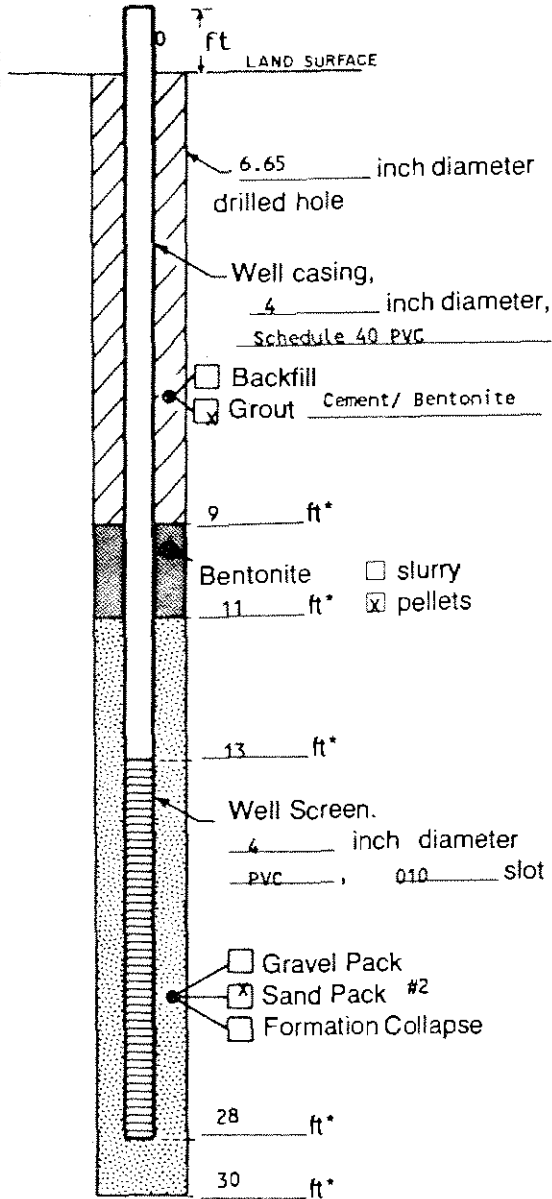

Measuring Point is
Top of Well Casing
Unless Otherwise Noted.

*Depth Below Land Surface

**ALTRESCO
SOIL BORING AND WELL CONSTRUCTION LOGS**

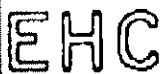

ENVIRONMENTAL
HYDROGEOLOGY CORPORATION
RTE. 148 CLIFTON PARK, N.Y. 371-7821

TEST BORING LOG

BORING No. W-1

PROJECT Co-Generation Plant Water Supply Study

SHEET 1 OF 3

CLIENT Altresco

JOB No. 91015.043H

DRILLING CONTRACTOR Hanson Well Drilling & Pump

MEAS. PT. ELEV.

PURPOSE Water Supply Investigation

GROUND ELEV.

DRILLING METHOD Mud Rotary

SAMPLE

CORE

CASING

DATUM

DRILL RIG TYPE IR-TH-60

TYPE

Grab

-

Steel

DATE STARTED 9/26/88

GROUNDWATER DEPTH

DIAM.

8 3/4"

-

8"

DATE FINISHED 9/30/88

MEASURING POINT

WEIGHT

-

DRILLER

DATE OF MEASUREMENT

FALL

-

INSPECTOR S. Revell -LAG Inc.

DEPTH FT.	SAMPLE NUMBER	BLOWS ON SAMPLE SPOON PER 6"	UNITED CLASSIFICATION	GRAPHIC LOG	GEOLOGIC DESCRIPTION	REMARKS
			SM		SAND, some silt, trace Clay 3.0'	Geologic description based on log from Hanson Well Drilling & Pump
			SC		SAND, some brown Clay 21.0'	
25			SC		Gr till/Hardpan 60.0'	Drilled w/ 12 1/4" bit to 66 feet.
50					yw/wh dolomitic marble 66.0'	
75					yw dolomitic marble and wh dolomitic marble	
100						

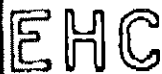

ENVIRONMENTAL
HYDROGEOLOGY CORPORATION
RTE.148 CLIFTON PARK, N.Y. 371-7821

TEST BORING LOG

BORING No. W-1

PROJECT Co-Generation Plant Water Supply Study

SHEET 2 OF 3

CLIENT Altresco

JOB No. 91095.043H

DEPTH FT.	SAMPLE NUMBER	BLOWS ON SAMPLE SPOON PER 6"	UNIFIED CLASSIFICATION	GRAPHIC LOG	GEOLOGIC DESCRIPTION	REMARKS
100					<p style="text-align: right;">103.0'</p> <p>yw dolomitic marble and wh dolomitic marble trace seams br dolomitic marble</p>	
125						
150					<p style="text-align: right;">151.0'</p> <p>Br dolomitic marble trace seams Sand, trace voids</p>	
175						
200						
225						<p>4" sand filled voids at 2" and 215'</p>

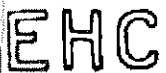

ENVIRONMENTAL
HYDROGEOLOGY CORPORATION
RTE. 148 CLIFTON PARK, N.Y. 371-7821

TEST BORING LOG

BORING No. W-

PROJECT Co-Generation Plant Water Supply Study

SHEET 3 OF 3

CLIENT Altresco

JOB No. 91095.043H

DEPTH FT.	SAMPLE NUMBER	BLOWS ON SAMPLE SPOON PER 6"	UNIFIED CLASSIFICATION	GRAPHIC LOG	GEOLOGIC DESCRIPTION	REMARKS
225						
250						
275						
300						
325						
350						



ENVIRONMENTAL
HYDROGEOLOGY CORPORATION
RTE. 148 CLIFTON PARK, N.Y. 371-7821

TEST BORING LOG

BORING No. W-2

PROJECT Co-Generation Plant Water Supply Study

SHEET 1 OF 3

CLIENT Altresco

JOB No. 91015.043H

DRILLING CONTRACTOR Hanson Well Drilling & Pump

MEAS. PT. ELEV.

PURPOSE Water Supply Investigation

GROUND ELEV.

DRILLING METHOD Mud Rotary

SAMPLE

CORE

CASING

DATUM

DRILL RIG TYPE IR-TH-60

TYPE

Grab

-

Steel

DATE STARTED 10/01/88

GROUNDWATER DEPTH

DIAM.

8 3/4"

-

8"

DATE FINISHED 10/05/88

MEASURING POINT

WEIGHT

-

DRILLER

DATE OF MEASUREMENT

FALL

-

INSPECTOR S. Revell -LAG Inc.

DEPTH FT.	SAMPLE NUMBER	BLOWS ON SAMPLE SPOON PER B.	UNIFIED CLASSIFICATION	GRAPHIC LOG	GEOLOGIC DESCRIPTION	REMARKS
25			SM		Br SAND, some Clay	Geologic description based on log from Hanson Well Drilling & Pump
50			SC		till/hard pan	
75						76.0'
					Br dolomitic marble with white streaks	Total depth of 8" Casing 78'
100						

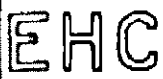

ENVIRONMENTAL
HYDROGEOLOGY CORPORATION
RTE.146 CLIFTON PARK, N.Y. 371-7821

TEST BORING LOG

BORING No. W-2

PROJECT Co-Generation Plant Water Supply Study

SHEET 2 OF 3

CLIENT Altresco

JOB No. 91095.043H

DEPTH FT	SAMPLE NUMBER	BLOWS ON SAMPLE SPOON PER 6"	UNIFIED CLASSIFICATION	GRAPHIC LOG	GEOLOGIC DESCRIPTION	REMARKS
100						
225						

Br dolomitic marble with white streaks

Well caved in to 126 feet



ENVIRONMENTAL
HYDROGEOLOGY CORPORATION
RTE. 140 CLIFTON PARK, N.Y. 371-7621

TEST BORING LOG

BORING No. W-2

PROJECT Co-Generation Plant Water Supply Study

SHEET 3 OF 3

CLIENT Altresco

JOB No. 91095.043H

DEPTH FT.	SAMPLE NUMBER	BLOWS ON SAMPLE SPoon PER FT.	UNIFIED CLASSIFICATION	GRAPHIC LOG	GEOLOGIC DESCRIPTION	REMARKS
225						
250					Br dolomitic marble with white streaks	
275						
300					Total Depth of Boring @ 291'	
325						
350						

PROJECT Co-Generation Plant Water Supply Study

SHEET 1 OF 5

CLIENT Altresco

JOB No. 91015.043H

DRILLING CONTRACTOR Hanson Well Drilling & Pump

MEAS. PT. ELEV.

PURPOSE Water Supply Investigation

GROUND ELEV.

DRILLING METHOD Mud Rotary

SAMPLE

CORE

CASING

DATUM

DRILL RIG TYPE IR-TH-60

TYPE

Grab

-

Steel

DATE STARTED 10/06/88

GROUNDWATER DEPTH

DIAM.

14 1/2" / 11 7/8" -

DATE FINISHED

MEASURING POINT

WEIGHT

9 7/8"

DRILLER

DATE OF MEASUREMENT

FALL

-

INSPECTOR S. Revell -LAG Inc.

DEPTH FT.	SAMPLE NUMBER	BLOWS ON SAMPLE SPOON PER 6"	UNIFIED CLASSIFICATION	GRAPHIC LOG	GEOLOGIC DESCRIPTION	REMARKS
			SW		Very coarse gravelly SAND with quartz, bits of schist	Geologic Description supplied by
			SW		Very coarse gravelly Sand and abundance of quartz	
25			SW		Very coarse gravelly Sand, pieces of schist quartz	
			SW		Very coarse gravel, beginning to get dolomitic marble with gravel	
50			SW		Fine Gravelly mud, quartz, no dolomitic marble small pieces of schist	
			SW		Olive: Same as above;	
			SW		Same as above; increased mud content, larger cuttings	
75			SW		Light tan schist, quartz, gravel, with mud	
			Sw		Light tan weathered dark Brown chert, very fine gravel	
100			SW		Chert, dark brown, micro-crystalline, gravel also present	

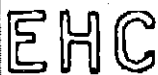

ENVIRONMENTAL
HYDROGEOLOGY CORPORATION
RTE. 148 CLIFTON PARK, N.Y. 371-7021

TEST BORING LOG

BORING No. W-3

PROJECT Co-Generation Plant Water Supply Study

SHEET 2 OF 5

CLIENT Altresco

JOB No. 91095.043H

DEPTH FT.	SAMPLE NUMBER	BLOWS ON SAMPLE SPOON PER 6"	UNIFIED CLASSIFICATION	GRAPHIC LOG	GEOLOGIC DESCRIPTION	REMARKS
100					dolomitic marble with bands of chert	
					dolomitic marble with pieces of chert sand bits of micaceous saprolitic present	
					dolomitic marble, cert quartz	large cuttings
125					Dolomitic marble also highly weathered micaceous, muscovite saprolite	large cuttings
					Same as above;	Large cutting Iron Stain noted
150					Same as above;	Smaller cuttings
					Same as above;	
175					Chert nodules large pieces of chert, small dolomitic marble cuttings Dolomitic marble, weathered Sand Concretions	Large cuttings
					Dolomitic marble, some chert	grainy texture
200					Same as above;	
					Same as above;	
225					Same as above;	

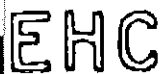

ENVIRONMENTAL
HYDROGEOLOGY CORPORATION
RTE. 148 CLIFTON PARK, N.Y. 371-7821

TEST BORING LOG

BORING No. W-3

PROJECT Co-Generation Plant Water Supply Study

SHEET 3 OF 5

CLIENT Altresco

JOB No. 91095.043H

DEPTH FT.	SAMPLE NUMBER	BLOWS ON SAMPLE SPOON PER FT.	UNIFIED CLASSIFICATION	GRAPHIC LOG	GEOLOGIC DESCRIPTION	REMARKS
225					Dolomitic marble, some chert, little quartz	
					Same as above;	
250						
					Same as above;	
275					Same as above;	
					Same as above;	
					290.0'	
					Quartzite	
300						
325						
350						

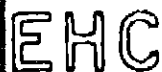

ENVIRONMENTAL
HYDROGEOLOGY CORPORATION
RTE. 148 CLIFTON PARK, N.Y. 371-7821

TEST BORING LOG

BORING No. W-3

PROJECT Co-Generation Plant Water Supply Study

SHEET 5 OF 5

CLIENT Altresco

JOB No. 91095.043H

DEPTH FT	SAMPLE NUMBER	BLOWS ON SAMPLE SPOON PER 6"	UNIFIED CLASSIFICATION	GRAPHIC LOG	GEOLOGIC DESCRIPTION	REMARKS
475					Quartzite	
500					Total Depth of Boring @ 490'	
525						
550						
575						
580						

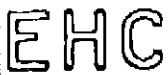

ENVIRONMENTAL
HYDROGEOLOGY CORPORATION
RTE. 148 CLIFTON PARK, N.Y. 371-7821

TEST BORING LOG

BORING No. W-4

PROJECT	Co-Generation Plant Water Supply Study				SHEET 1 OF 5
CLIENT	Altresco				JOB No. 91015.043H
DRILLING CONTRACTOR	Hanson Well Drilling & Pump				MEAS. PT. ELEV.
PURPOSE	Water Supply Investigation				GROUND ELEV.
DRILLING METHOD	Mud Rotary	SAMPLE	CORE	CASING	DATUM
DRILL RIG TYPE	IR-TH-60	TYPE	Grab	-	Steel
GROUNDWATER DEPTH		DIAM.	36/24/15	-	26/16/12
MEASURING POINT		WEIGHT	-		DRILLER
DATE OF MEASUREMENT		FALL	-		INSPECTOR S. Revell -LAG Inc.

DEPTH FT	SAMPLE NUMBER	BLOWS ON SAMPLE SPOON PER 6"	UNIFIED CLASSIFICATION	GRAPHIC LOG	GEOLOGIC DESCRIPTION	REMARKS
25			SC		Till/Hardpan	
50						
75						
70.0'						
					Dolomitic Marble	End of 36" Boring at 80'
100						

PROJECT Co-Generation Plant Water Supply Study

SHEET 2 OF 5

CLIENT Altresco

JOB No. 91095.043H

DEPTH FT.	SAMPLE NUMBER	BLOWS ON SAMPLE SPOON PER 6"	UNIFIED CLASSIFICATION	GRAPHIC LOG	GEOLOGIC DESCRIPTION	REMARKS
100						
125					Dolomitic marble	
150						
175						
200						
225						



ENVIRONMENTAL
HYDROGEOLOGY CORPORATION
RTE. 148 CLIFTON PARK, N.Y. 371-1821

TEST BORING LOG

BORING No. W-4

PROJECT Co-Generation Plant Water Supply Study

SHEET 4 OF 5

CLIENT Altresco

JOB No. 91095.043H

DEPTH FT.	SAMPLE NUMBER	BLOWS ON SAMPLE SPOON PER 6"	UNIFIED CLASSIFICATION	GRAPHIC LOG	GEOLOGIC DESCRIPTION	REMARKS
350					Dolomitic marble	
375						
						380.0' End of 24" boring at 380'
400					Quartzite	
425						Fracture zones at 420 to 425'
450						
475						

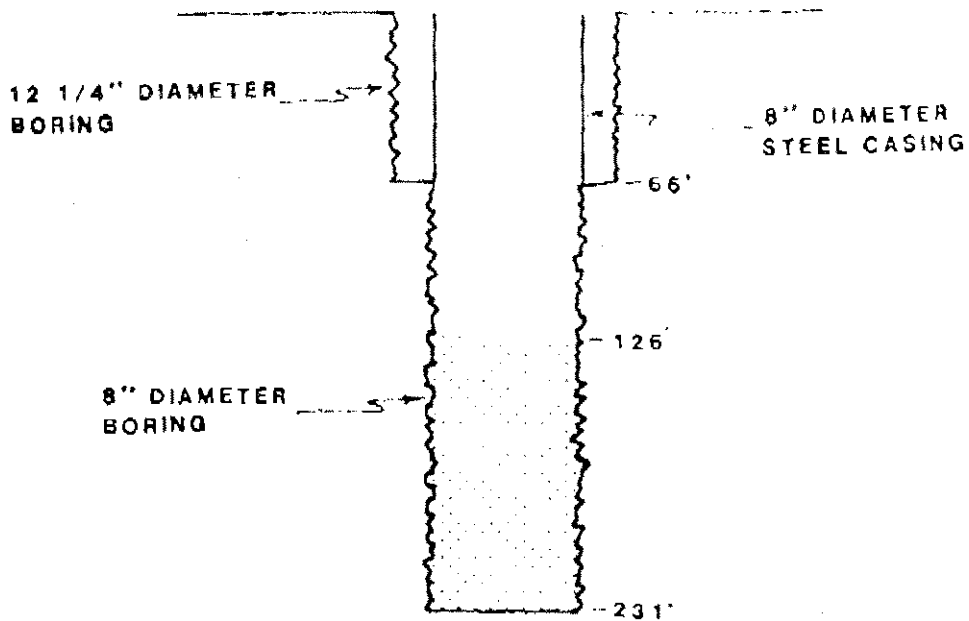

PRODUCTION WELL WAS CONSTRUCTED
 AND DESIGNED BY HANSON WELL DRILLING &
 PUMP UTILIZING ROTARY DRILLING METHODS

WELL HAS HEAVED BACK TO 126 FEET

PRODUCTION WELL W-2
 CONSTRUCTION DIAGRAM

EHC ENVIRONMENTAL
 HYDROGEOLOGY
 CORPORATION

ROUTE 146, GARDEN PARK, NEW YORK 11755 (516) 754-7200
 WATER RESOURCES GEOTECHNICAL ENGINEERING
 CONTAMINANT TOXICOLOGY INDUSTRIAL WASTE/RECLAMATION

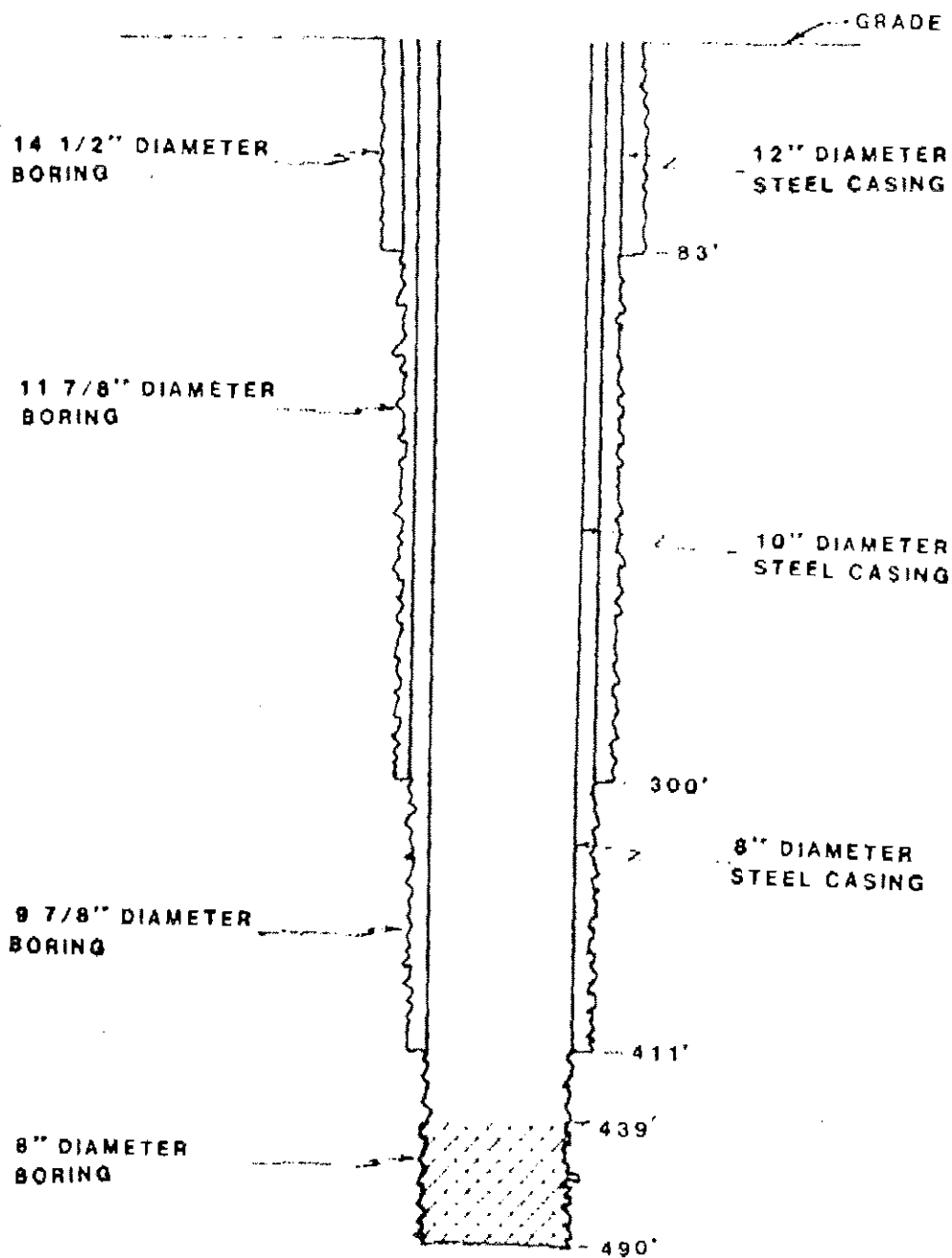

PRODUCTION WELL WAS CONSTRUCTED
AND DESIGNED BY HANSON WELL DRILLING &
PUMP UTILIZING ROTARY DRILLING METHODS

WELL HAS COLLAPSED BACK TO 439 FEET

PRODUCTION WELL W-3
CONSTRUCTION DIAGRAM

EHC ENVIRONMENTAL
HYDROGEOLOGY
CORPORATION

ROUTE 146, LITTLETON PARK, NEW YORK 12550 (518) 578-7622
WATER RESOURCES GEOTECHNICAL ENGINEERING
CONTAMINANT DECONTAMINATION INDUSTRIAL RESOURCE MINING

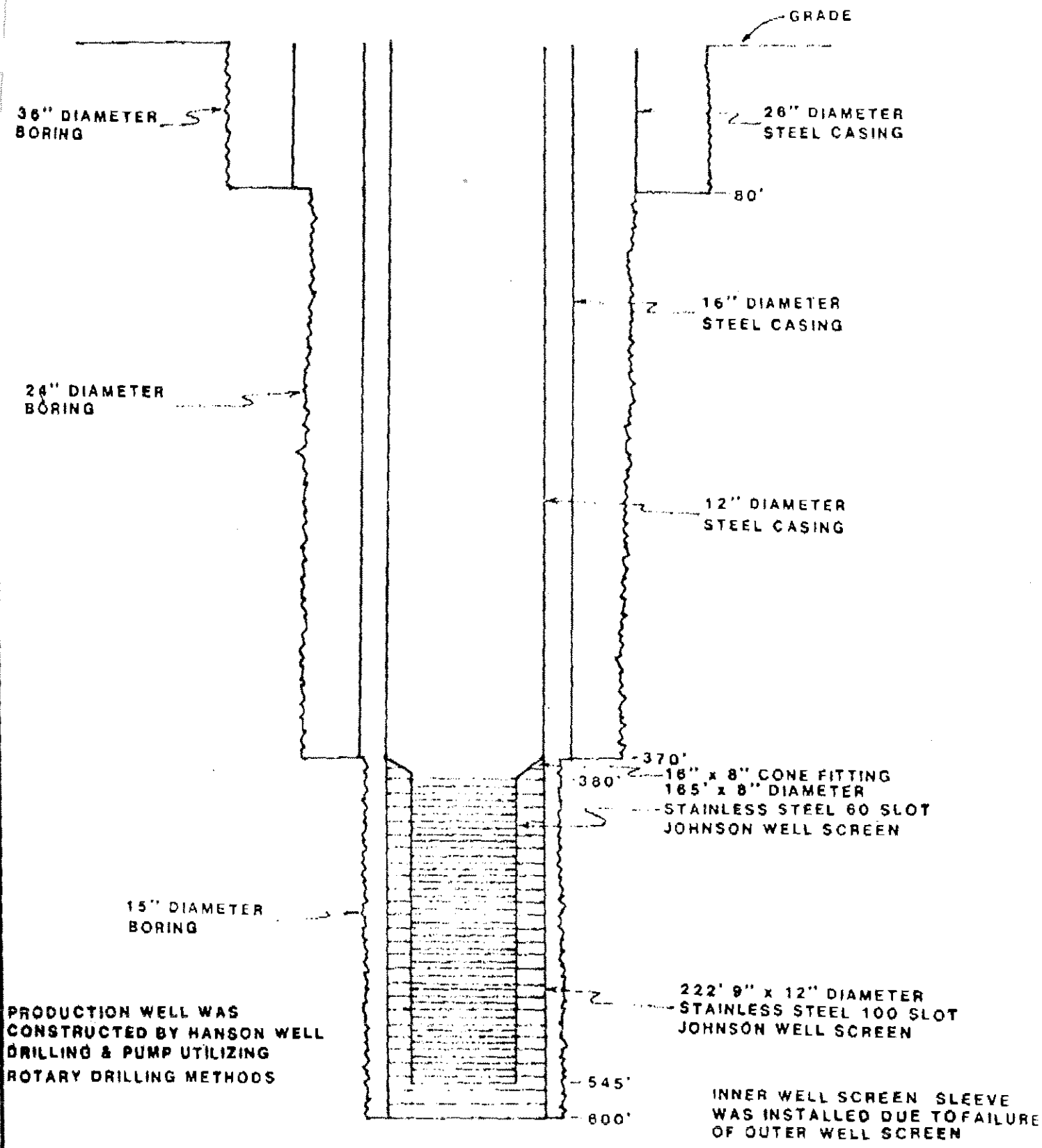

**PRODUCTION WELL W-4
CONSTRUCTION DIAGRAM**

EHC ENVIRONMENTAL
HYDROGEOLOGY
CORPORATION

ROUTE 146, MILLTON PARK, NEW YORK, NY 12551
 WATER RESOURCES DIVISION OF THE DEPARTMENT OF ENVIRONMENTAL
 CONSERVATION, STATE OF NEW YORK, ALBANY, NY 12242



LOG OF WELL

Well No. 5 Job. No. _____ Test No. 1
 Log of Well for (Owner) ALTRESKO Corp Well # 5
 Address PITTSFIELD MASS 018
 Representatives, if any HANSON
 Well Located at PITTSFIELD in _____ County, State of MASS
 Furnish sketch of location _____ Date Drilling started 4-25-90 Date Test Hole Completed _____
 Total depth to bottom of Well 457' Diameter Test Hole 12" X 6" Elevation at Ground Level, if available _____
 Elevation at Ground Level, if available _____ Distance from where measurements were taken to ground level _____
 Water stands when not pumping 11 feet _____ inches from the surface of the ground
 All Measurements taken from _____

THICKNESS OF STRATUM	DEPTH TO BOTTOM OF STRATA	Length of Core Taken	FORMATION FOUND EACH STRATUM	THICKNESS OF STRATUM	DEPTH TO BOTTOM OF STRATA	Length of Core Taken	FORMATION FOUND EACH STRATUM
10'	0'-10'		Dark Brown Silty Sand and Gravel				Clay and Brock Light Brown Bedrock
				8'	165'-173'		Light Brown Sand Stone
15'	10'-25'		Light Brown Fine To Course Sand and Gravel.	11'	173'-184'		Harder Bedrock
				13'	184'-197'		Grey Brown Silty Clay Sand and Clay
17'	25'-42'		Same as above				(Covered)
8'	42'-50'		With more Gravel	2'	197'-199'		Same with Bedrock
8'	42'-50'		Brown Hard Pan				Bedrock
40'	50'-90'		Grey Brown Hard Pan	16'	199'-215'		Hard Grey Brown Bedrock
37'	90'-127'		Light Brown Bedrock, Very Soft.	3'	215'-218'		Reddish Brown Bedrock Soft
				22'	218'-240'		Same as above
8'	127'-135'		Red Silty Sand and Clay (Covered)	10'	240'-250'		But Very hard Soft
30'	135'-165'		Red Silty Sand	15'	250'-265'		Same But Red

Remarks and opinion of Test

CHECK TYPE OF RIG USED

- Reverse Rotary
- Cable Tool
- Wash
- Other?

Daniel Leann
Driller



Page 2
LOG OF WELL

LAYNE WELL & PUMP DIVISION

Well No. 5 Job. No. _____ Test No. 1
 Log of Well for (Owner) ALTRESKO Well No. 5
 Address PITTSFIELD MASS

Representatives, if any _____
 Well Located at _____ in _____ County, State of _____
 Furnish sketch of location _____ Date Drilling started _____ Date Test Hole Completed _____
 Total depth to bottom of Well _____ Diameter Test Hole _____ Elevation at Ground Level, if available _____
 Elevation at Ground Level, if available _____ Distance from where measurements were taken to ground level _____
 Water stands when not pumping _____ feet _____ inches from the surface of the ground
 All Measurements taken from _____

THICKNESS OF STRATUM	DEPTH TO BOTTOM OF STRATA	Length of Core Taken	FORMATION FOUND EACH STRATUM	THICKNESS OF STRATUM	DEPTH TO BOTTOM OF STRATA	Length of Core Taken	FORMATION FOUND EACH STRATUM
15'	265'-280'		Same as above		318'		40 GPM ^{Cav} _{Clear}
			BUT STIFFER		322'		60 "
10'	280'-290'		SOFT (Cavern)		330'		150 "
5'	290'-295'		HARDER		332'		200 "
32'	295'-327'		Broken Quar-		342		5 GPM
			Tize. Very hard		362		60 "
7'	327'-334'		Same But Reddish		369		200 GPM "
			Brown		400'		150' "
11'	334'-345'		Light Brown		421'		150 "
			BedRock		421'		225 "
14'	345'-359'		Broken BedRock		430'		225* GPM MILK
34'	359'-393'		Broken BedRock		437'		225 " "
			and Brown Silty		457'		260 " "
			SAND		450'		300 " "
64'	393'-457'		STREAKS OF		448		300 " "
			HARD BEDROCK				
			WITH FRACTURES				
			and Broken Zones				

Remarks and opinion of Test

CHECK TYPE OF RIG USED

Reverse
 Rotary
 Cable Tool
 Wash
 Other?

David L...
 Driller

HYDRO GROUP DRILLERS REPORT

JOB No. _____ DRILLER Darrell Loan CUSTOMER WELL No. 5
 CUSTOMER ALTRESCO WELL No. 5
 WELL LOCATION PITTSFIELD MASS STATE PERMIT No. _____
 FORMATION _____ SKETCH OF SETTING _____ REMARKS _____

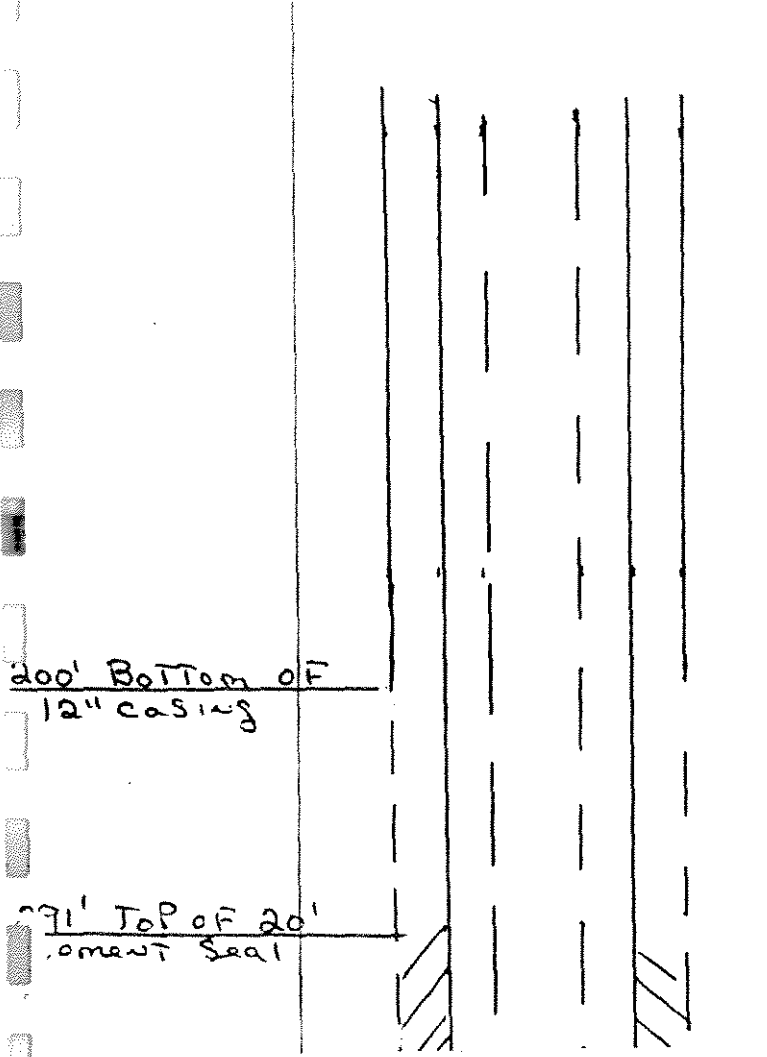

PIPE SET:

DIA.	WALL	LGTH.	MATL.	T & C WELD
12"	3/8"	200'	Steel	
8"	3/8"	339'	Steel	
6"	3/8"	427'	Steel	

PIPE LEFT IN PLACE:

DIA.	WALL	LGTH.	MATL.	T & C WELD
12"		200'		
8"		339'		
6"		121'		

SCREEN:

NOM. SIZE 6" to I.D. 5" LGTH. 16' OPNG. 500S
 MFG. COOK TYPE W METAL S.S GA. NO. _____
 SET IN Bad Rock (Bail Bottom) FORMATION _____
 WELL UNDERREAMED TO _____ DIAMETER 5" Threaded

MISCELLANEOUS:

R & L BACK OFF _____ CUT OFF _____ PACKER TYPE _____

CONE:

DIA. TOP _____ DIA. BOT. _____ LGTH. _____ MTL. _____

PLUG:

DIA. _____ LGTH. _____ MTL. _____

GRAVEL:

AMT. _____ BAGS PWDR. REG. _____

CLAY:



LOG OF WELL

Well No. 6 Job. No. _____ Test No. 6
 Log of Well for (Owner) ALFRESCO
 Address PITSFIELD GA
 Representatives, if any HOUSON ASS.
 Well Located at PITSFIELD in _____ County, State of GA
 Furnish sketch of location _____ Date Drilling started _____ Date Test Hole Completed _____
 Total depth to bottom of Well 430' Diameter Test Hole 16" x 8" Elevation at Ground Level, if available _____
 Elevation at Ground Level, if available _____ Distance from where measurements were taken to ground level _____
 Water stands when not pumping 45' feet _____ inches from the surface of the ground
 All Measurements taken from _____

THICKNESS OF STRATUM	DEPTH TO BOTTOM OF STRATA	Length of Core Taken	FORMATION FOUND EACH STRATUM	THICKNESS OF STRATUM	DEPTH TO BOTTOM OF STRATA	Length of Core Taken	FORMATION FOUND EACH STRATUM
5'	0'-5'		Brown Silty Fine To Course Sand	6'	104'-110'		Same But REDDISH
			and Gravel	15'	110'-125'		Brown Hard Red
				18'	125'-143'		Softer Red
15'	5'-20'		Grey Silty Sand Clay some Gravel	15'	143'-158'		Changes From Grey Brown To Red.
22'	20'-42'		Grey Brown Fine To Course Sand				Grey Brown is Hard Red is Soft
			and Gravel, Boulders (Hard Packed)	3'	158'-161'		Grey Hard
				4'	161'-165'		Soft Red
1'	42'-43'		Boulder (could be top of Bed Rock)	17'	165'-182'		Grey
				2' 50"	182'-184.50		Red
20'	43'-63'		Grey Fine To Course Sand and Gravel	8' 50"	184.50-193'		Grey
				4'	193'-197'		Red
			Tight (Takes None)	6' 50"	197'-202.50		Grey
18'	63'-81'		Brown and Grey Soft Bed Rock	7' 50"	202.50-210'		Softer Grey
				4'	210'-214'		Broken Hard
23'	81'-104'		Some But Softer (Takes a little mud)	7'	214'-221'		Red
				5'	221'-226'		Broken Hard

Remarks and opinion of Test

CHECK TYPE OF RIG USED

- Reverse Rotary
- Cable Tool
- Wash
- Other?

[Signature]
 Driller

LOG OF WELL

Well No. 6 Job No. _____ Test No. 6
 Log of Well for (Owner) ALTRESA
 Address PITSFIELD 68
 Representatives, if any HANSON
 Well Located at PITSFIELD in _____ County, State of MASS
 Furnish sketch of location _____ Date Drilling started _____ Date Test Hole Completed _____
 Total depth to bottom of Well 434' Diameter Test Hole 16"x8" Elevation at Ground Level, if available _____
 Elevation at Ground Level, if available _____ Distance from where measurements were taken to ground level _____
 Water stands when not pumping 45' feet _____ inches from the surface of the ground
 All Measurements taken from _____

THICKNESS OF STRATUM	DEPTH TO BOTTOM OF STRATA	Length of Core Taken	FORMATION FOUND EACH STRATUM	THICKNESS OF STRATUM	DEPTH TO BOTTOM OF STRATA	Length of Core Taken	FORMATION FOUND EACH STRATUM
25'	226'-251'		SOFT	35'	333'-368'		Broken Soft
14'	251'-265'		SOFT Broken	1'	368'-369'		Hard
			White Rock	6'	369'-375'		Broken Hard
11'	265'-276'		SOFT White	5'	375'-380'		Hard
3'	276'-279'		Hard	2'	380'-382'		Softer
3'	279'-280'		SOFT	8'	380'-390'		Softer
5'	280'-287'		Broken Rock	2'	390'-392'		Broken
6'	287'-293'		SOFT	10'	392'-402'		White Fractured
2'	293'-295'		Very Broken	10'	402'-412'		Broken with 6"
9'	295'-304'		SOFT				2' streaks of H
3'	304'-307'		Broken Reddish	11'	412'-423'		Some with very S
2'	307'-309'		Very Soft Red				with blue
7.50	307'-314.50		Very hard white	13'	423'-436'		Broken Hard 1'
6.50	316.50-323'		Very hard (2'				1' streaks of U
	321-322		Red Dry)				Hard
3'	323'-326'		Broken Hard	18'50	436'-454'50		Some with large
4'	326'-330'		Broken Softer				of Very Broken
3'	330'-333'		Hard				

Remarks and opinion of Test
Changes from Hard to Broken at Bottom easy from broken
Too Hard to Tell Depth Accurately

CHECK TYPE OF RIG USED { Reverse Rotary Cable Tool Wash Other? }
 Driller R. ...



LOG OF WELL

Well No. 6 Job. No. _____ Test No. 6
 Log of Well for (Owner) Altresco
 Address PITSFIELD MA
 Representatives, if any HANSON
 Well Located at PITSFIELD in _____ County, State of Mass
 Furnish sketch of location _____ Date Drilling started _____ Date Test Hole Completed _____
 Total depth to bottom of Well 450' Diameter Test Hole 16" x 8" Elevation at Ground Level, if available _____
 Elevation at Ground Level, if available _____ Distance from where measurements were taken to ground level _____
 Water stands when not pumping 45' feet _____ inches from the surface of the ground
 All Measurements taken from _____

THICKNESS OF STRATUM	DEPTH TO BOTTOM OF STRATA	Length of Core Taken	FORMATION FOUND EACH STRATUM	THICKNESS OF STRATUM	DEPTH TO BOTTOM OF STRATA	Length of Core Taken	FORMATION FOUND EACH STRATUM
350'	40 GPM		MILKY				
370'	125 GPM		MILKY				
382'	125 GPM		MILKY				
397'	160 GPM		MILKY				
397'	225 GPM		MILKY				
405'	250 GPM		MILKY				
425'	300 GPM		MILKY				
443'	125 GPM		MILKY (Very)				
449'	250 GPM		MILKY (Very)				
<p>The longer you Blow on ANY Area The clearer the water gets But it is still MILKY</p> <p>Blew 100 GPM AT 212' Then OPEN END OF 12" casing</p>							

Remarks and opinion of Test

CHECK TYPE OF Reverse Rotary Cable Tool

S. Wallace

**NEW YORK AVENUE
SOIL BORING AND WELL CONSTRUCTION LOGS**

SAMPLE/CORE LOG

WELL: NY-2 PROJECT NO: NY360NY01 New York Ave.
PAGE: 1 of 1

SITE General Electric DRILLING DRILLING
 LOCATION: Pittsfield, MA STARTED: 4/26/88 COMPLETED: 4/26/88

TOTAL DEPTH 24 ft HOLE DIAMETER: 8 in. TYPE OF SAMPLE/
 DRILLED: 24 ft CORING DEVICE: Split Spoon

LENGTH & DIAMETER SAMPLING
 OF CORING DEVICE: 2 ft x 2 in. INTERVAL: 2 ft

LAND-SURFACE { } SURVEYED
 ELEVATION: { } ESTIMATED DATUM:

DRILLING FLUID USED: None DRILLING METHOD: Hollow Stem Auger

DRILLING CONTRACTOR: Soil & Mat'l. Testing DRILLER: Tom HELPER: Bob

PREPARED BY: W. Gray HAMMER WEIGHT: 140 lb HAMMER DROP: 30 in.

SAMPLE NO	SAMPLE DEPTH		CORE RECVRY	BLOW COUNTS	SAMPLE/CORE DESCRIPTION
	FROM	TO			
	0	2	0.6	2-3-	Sand, medium to fine (90%); trace silt, little
				3-4	gravel, brown.
	2	4	1.0	4-4-	Sand (95%), poorly sorted; trace silt; little gravel,
				5-7	light brown.
	4	6	1.5	6-6-	Sand (85%), trace silt; increased gravel, small,
				5-5	light brown.
	6	8	1.5	10-8-	Same as above.
				8-10	
	8	10	1.6	10-12-	Same as above, gray-brown.
				12-12	
	10	12	2.0	12-6-	Same as above.
				7-7	
	12	14	0.4	12-8-	Same as above (2 in.). Fine sand and silt, trace
				7-22	clay, moist.
	14	16	0.4	8-10-	Sand, medium to fine (80%); some silt, little clay;
				8-8	little gravel, brown, moist
	16	18	1.1	12-11-	Same as above, with silt, increased gravel. Wet
				24-30	fragments of limestone at 18 ft.
	18	20	1.7	15-19-	Same as above, very silty.
				32-39	
	20	22	1.6	12-27-	Same as above.
				32-50	
	22	24	1.3	25-33-	Sand, fine, and silt; some gravel; very dense, drier
				47-97	than above, brown.

SAMPLE/CORE LOG

WELL: NY-3 PROJECT NO: New York Ave. NY360NY01 PAGE: 1 of 2

SITE General Electric DRILLING DRILLING
 LOCATION: Pittsfield, MA STARTED: 4/27/88 COMPLETED: 4/27/88

TOTAL DEPTH 25 ft HOLE DIAMETER: 8 in. TYPE OF SAMPLE/
 DRILLED: 25 ft CORING DEVICE: Split Spoon

LENGTH & DIAMETER 2 ft x 2 in. SAMPLING continuous
 OF CORING DEVICE: 2 ft x 2 in. INTERVAL: continuous

LAND-SURFACE { } SURVEYED
 ELEVATION: { } ESTIMATED DATUM:

DRILLING FLUID USED: None DRILLING METHOD: Hollow Stem Auger

DRILLING CONTRACTOR: Soil & Mat'l. Testing DRILLER: Mike HELPER: Bob

PREPARED BY: J. Duminuco HAMMER WEIGHT: 140 lb HAMMER DROP: 30 in.

SAMPLE NO	SAMPLE DEPTH		CORE RECVRY	BLOW COUNTS	SAMPLE/CORE DESCRIPTION
	FROM	TO			
	0	2	1.2	2-4-	Sand, fine, trace silt, gravel, vegetation, brown.
				9-6	
	2	4	1.7	5-4-	Sand, fine, some silt, brown.
				4-4	
	4	6	2.0	4-3-	Do
				3-3	
	6	8	1.8	3-3-	Do, trace gravel.
				4-6	
	8	10	1.6	12-14-	Sand, fine, some silt, trace gravel, brown-gray.
				18-15	
	10	12	1.0	16-17-	Sand, fine to medium, some silt, gravel, brown-gray.
				19-12	
	12	14	0.9	16-17-	Do
				12-9	
	14	16	1.2	6-6-	Do 14 to 15.8 ft; silt, some fine sand, brown,
				8-9	(15.8 to 16 ft), wet at tip.
	16	18	1.0	6-10-	(Interlayered) sand, fine, silty and sand fine to
				11-11	medium, trace silt, gravel, brown; (wet).
	18	20	1.4	10-10-	Silt, some fine sand, brown.
				10-16	
	20	22	0.9	13-13-	Sand, fine to medium, silty, some gravel, brown.
				14-14	
	22	24	1.4	18-26-	Silt, some fine sand, trace gravel, brown.
				17-20	

SAMPLE/CORE LOG

WELL: NY-4 PROJECT NO: NY360NY01 PAGE: 1 of 1
 New York Ave.
 SITE General Electric DRILLING DRILLING
 LOCATION: Pittsfield, MA STARTED: 5/2/88 COMPLETED: 5/2/88
 TOTAL DEPTH HOLE TYPE OF SAMPLE/
 DRILLED: 33 ft DIAMETER: 8 in. CORING DEVICE: Split Spoon
 LENGTH & DIAMETER SAMPLING
 OF CORING DEVICE: 2 ft x 2 in. INTERVAL: continuous
 LAND-SURFACE { } SURVEYED
 ELEVATION: { } ESTIMATED DATUM:
 DRILLING FLUID USED: None DRILLING METHOD: Hollow Stem Auger
 DRILLING
 CONTRACTOR: Soil & Mat'l. Testing DRILLER: Tom HELPER: Bob
 PREPARED BY: J. Duminuco HAMMER WEIGHT: 140 lb HAMMER DROP: 30 in.

SAMPLE NO	SAMPLE DEPTH		CORE RECVRY	BLOW COUNTS	SAMPLE/CORE DESCRIPTION
	FROM	TO			
	0	2	1.0	1-2-	Sand, fine to medium, trace gravel, silt, vegetation, brown.
				2-2	
	2	4	1.1	3-3-	Sand, fine to coarse, some gravel, trace silt, brown-gray.
				3-4	
	4	6	1.2	6-9-	Interlayered: sand, fine to coarse, some gravel, trace silt; sand, fine, silty; silt, sandy; brown.
				6-7	
	6	8	1.4	9-18-	Sand, fine to medium, silty and gravel, brown (damp).
				16-18	
	8	10	1.4	15-15-	Silt, sandy, trace gravel, brown; (wet).
				19-14	
	10	12	0.0	20-25-	No recovery - pushing cobbles - augered to 14.0 ft.
				40-120	
	14	16	1.0	11-9-	(Interlayered) Sand, fine, silty and silt, sandy, brown; (damp).
				12-17	
	16	18	0.9	16-20-	Silt, some fine sand, trace gravel, brown.
				22-27	
	18	20	0.8	29-50-	Sand, fine, some silt, trace gravel, brown; (damp).
				45-45	
	20	22	1.8	70-75-	Do
				50-70	
	22	24	1.1	11-16-	Sand, fine, trace silt, brown; (damp).
				32-37	

WELL CONSTRUCTION LOG
(UNCONSOLIDATED)

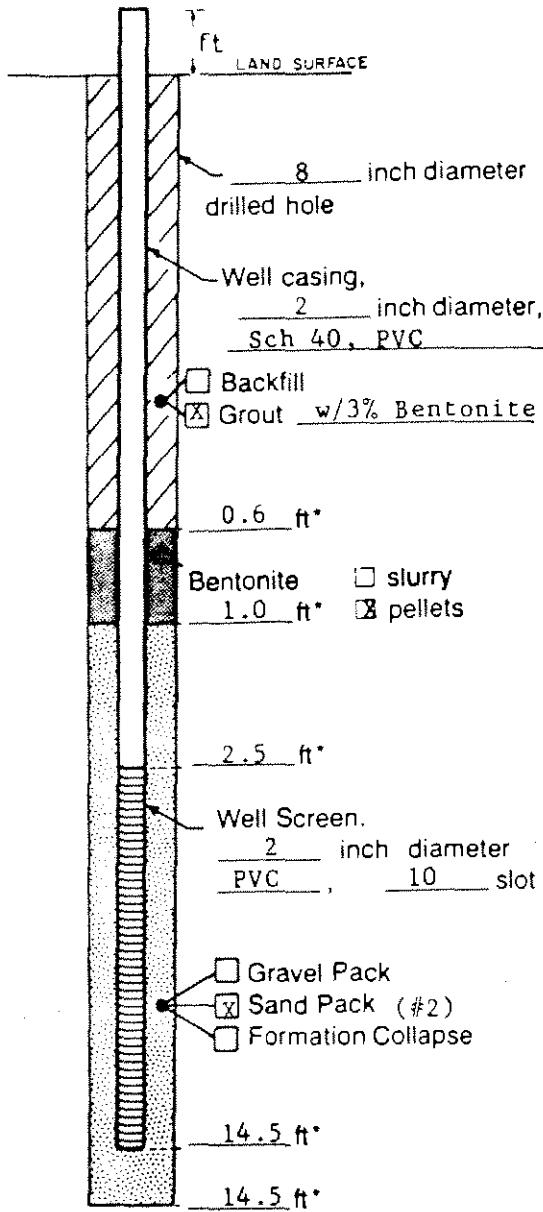

Measuring Point is
Top of Well Casing
Unless Otherwise Noted.

*Depth Below Land Surface

Project NY360NY01 Well NY-1

Town/City Pittsfield

County Berkshire State MA

Permit No. _____

Land-Surface Elevation
and Datum _____ feet Surveyed
 Estimated

Installation Date(s) 4/25/88

Drilling Method Hollow-Stem Auger

Drilling Contractor Soil & Material Testing

Drilling Fluid None

Development Technique(s) and Date(s)
4/26/88 - bailed and surged

Fluid Loss During Drilling _____ gallons

Water Removed During Development 16 gallons

Static Depth to Water _____ feet below M.P.

Pumping Depth to Water _____ feet below M.P.

Pumping Duration _____ hours

Yield _____ gpm Date _____

Specific Capacity _____ gpm/ft

Well Purpose Monitoring Well

Remarks _____

Prepared by W. Gray

WELL CONSTRUCTION LOG
(UNCONSOLIDATED)

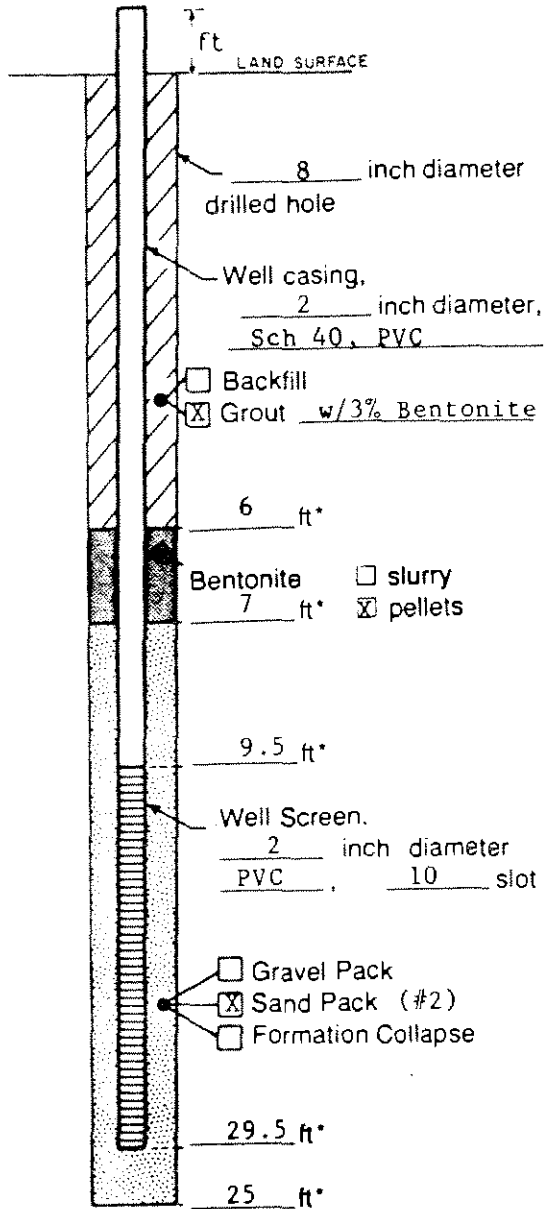

Measuring Point is
Top of Well Casing
Unless Otherwise Noted.

*Depth Below Land Surface

Project NY360NY01 Well NY-2

Town/City Pittsfield

County Berkshire State MA

Permit No. _____

Land-Surface Elevation
and Datum _____ feet Surveyed
 Estimated

Installation Date(s) 4/26/88

Drilling Method Hollow-Stem Auger

Drilling Contractor Soil & Material Testing

Drilling Fluid None

Development Technique(s) and Date(s)

4/26/88 - bailed and surged

4/27/88 - bailed and surged

Fluid Loss During Drilling _____ gallons

Water Removed During Development _____ gallons

Static Depth to Water _____ feet below M.P.

Pumping Depth to Water _____ feet below M.P.

Pumping Duration _____ hours

Yield _____ gpm Date _____

Specific Capacity _____ gpm/ft

Well Purpose Monitoring Well

Remarks _____

Prepared by W. Gray

WELL CONSTRUCTION LOG
(UNCONSOLIDATED)

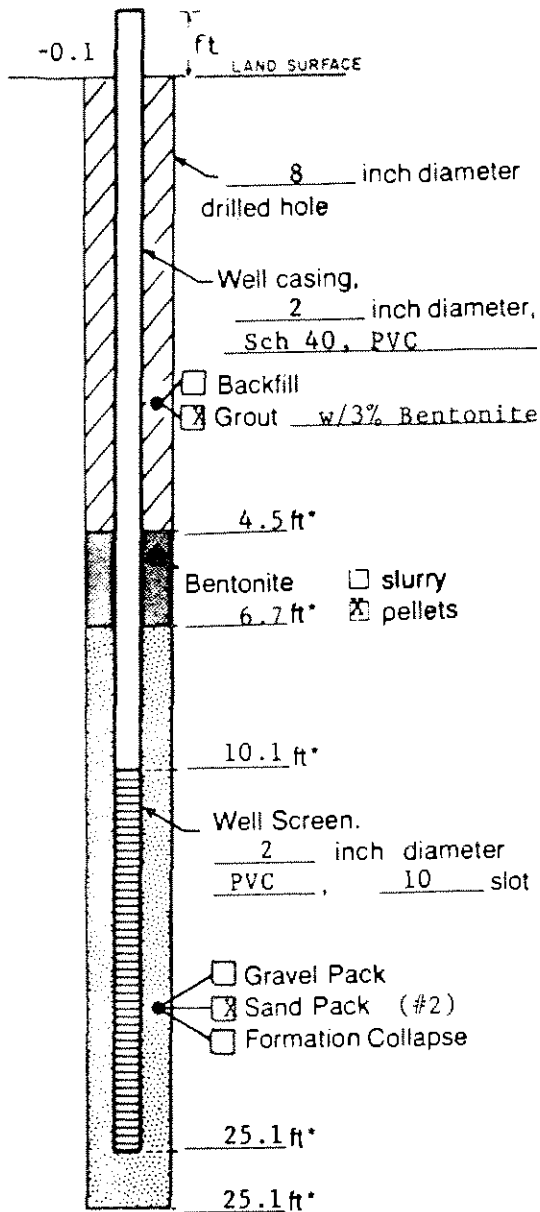

Measuring Point is
Top of Well Casing
Unless Otherwise Noted.

*Depth Below Land Surface

Project NY360NY01 Well NY-3

Town/City Pittsfield

County Berkshire State MA

Permit No. _____

Land-Surface Elevation _____

and Datum _____ feet Surveyed

_____ Estimated

Installation Date(s) 4/27/88

Drilling Method Hollow-Stem Auger

Drilling Contractor Soil & Material Testing

Drilling Fluid None

Development Technique(s) and Date(s)

4/22/88 Bailed and surged

Fluid Loss During Drilling _____ gallons

Water Removed During Development _____ gallons

Static Depth to Water _____ feet below M.P.

Pumping Depth to Water _____ feet below M.P.

Pumping Duration _____ hours

Yield _____ gpm Date _____

Specific Capacity _____ gpm/ft

Well Purpose Monitoring Well

Remarks _____

Prepared by J. Duminuco

WELL CONSTRUCTION LOG
(UNCONSOLIDATED)

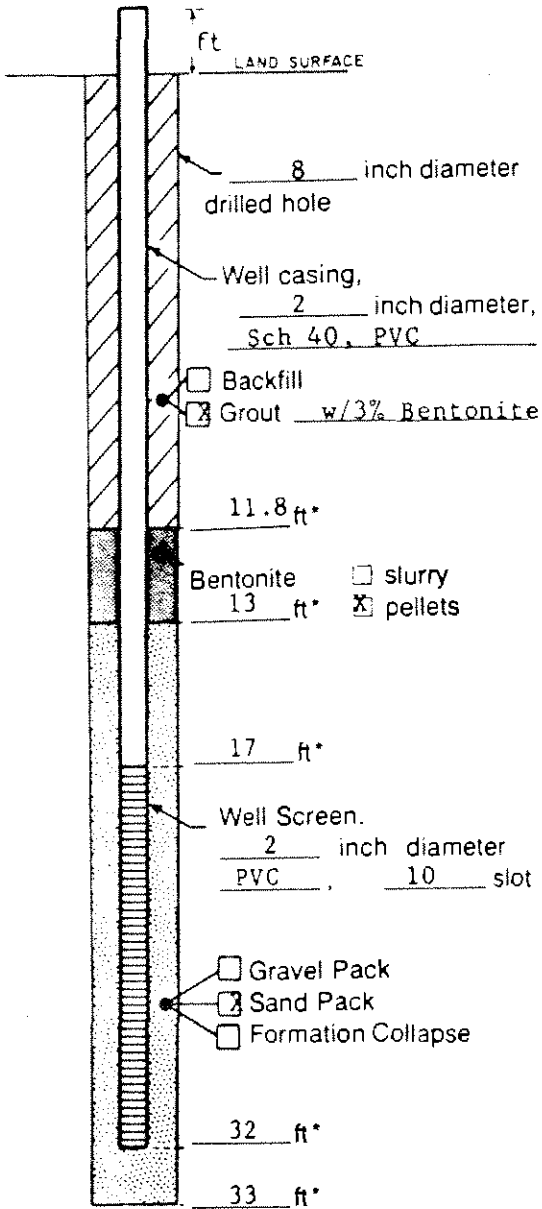

Measuring Point is
Top of Well Casing
Unless Otherwise Noted.

*Depth Below Land Surface

Project NY360NY01 Well NY-4

Town/City Pittsfield

County Berkshire State MA

Permit No. _____

Land-Surface Elevation
and Datum _____ feet Surveyed
 Estimated

Installation Date(s) 5/88

Drilling Method Hollow-Stem Auger

Drilling Contractor Soil & Material Testing

Drilling Fluid None

Development Technique(s) and Date(s)
Bailed and surged

Fluid Loss During Drilling _____ gallons

Water Removed During Development _____ gallons

Static Depth to Water _____ feet below M.P.

Pumping Depth to Water _____ feet below M.P.

Pumping Duration _____ hours

Yield _____ gpm Date _____

Specific Capacity _____ gpm/ft

Well Purpose Monitoring Well

Remarks _____

Prepared by J. Duminuco

APPENDIX I

**REPORT ON SOIL BORING PROGRAM FOR
ALTRESCO TREE PLANTINGS AND ANALYTICAL RESULTS**

FAX TRANSMISSION

April 30, 1990

Ms. Kristen Begor
GE Company
100 Woodlawn Avenue - Bldg 11-250
Pittsfield, MA 01201

Re: Soil Boring Program for Altresco Tree Plantings, GE/Altresco
Cogeneration Plant, Pittsfield, Massachusetts (Project No. NY05505)

Dear Kristen:

Enclosed are copies of the soil boring logs, site map, and photoionization detector results for the soil samples collected at the GE/Altresco Cogeneration Plant for landscaping and tree plantings.

Drilling operations took place on April 12-13, 1990 at the locations indicated on Figure 1. Soil samples were collected in two-foot intervals to the depths indicated in Table 1. All samples were screened for volatile organic compounds (VOCs) using a TIPSM photoionization detector. The results obtained are presented in Table 1. The samples were then submitted to OBG Laboratories, Inc. for PCB analysis.

If you have any questions, please do not hesitate to call us.

Sincerely,

GERAGHTY & MILLER, INC.



William J. Gray
Project Scientist



Dennis Colton
Principal Scientist

DC:WJG/clc

TABLE 1. SUMMARY OF PHOTOIONIZATION DETECTOR RESULTS FOR SOIL SAMPLES COLLECTED AT GENERAL ELECTRIC COMPANY, ALTRESCO COGENERATION PLANT, PITTSFIELD, MASSACHUSETTS, APRIL 12 AND 13, 1990

Sample Interval (feet) and correlating TIP Results (ppm)^a

<u>Boring No.</u>	<u>0-2 Feet</u>	<u>2-4 Feet</u>	<u>4-6 Feet</u>
L-1	0.0	0.0	--
L-2	0.0	0.0	--
L-3	0.0	0.0	--
L-4	0.0	0.0	--
L-5	0.0	0.0	--
L-6	0.0	0.0	--
L-7	0.0	0.0	--
L-8	0.0	0.0	0.0
L-9	0.0	0.0	--
L-10	0.0	0.0	--
L-11	0.0	*	--
L-12	0.0	0.0	--
L-13	0.0	*	--
L-14	0.0	0.0	--
L-15	0.0	0.0	--
L-16	0.0	0.0	--
L-17	0.0	0.0	0.0
L-18	0.0	0.0	--
L-19	0.01	0.0	0.0
L-20	0.0	0.0	--
L-21	0.0	0.0 ^b	--
L-22	0.0	0.0	--
L-23	0.0	0.0	--
L-24	0.0	0.0	--

^aThese values are qualitative only and do not represent the absolute concentrations of any volatile organic compound in the soil core, whether the compound is natural or man-made.

*No recovery, no sample submitted.

--No sample taken at this depth.

^bSpoon refusal occurred at three (3) feet on sample L-21.



COMPILED BY: A. LABARGE
PREPARED BY: R. FAULK
PROJECT WORK: W. GRAY

DATE: 4/19/90
SCALE: shown
PILE NO: NYD5505

PREPARED FOR:
**GENERAL ELECTRIC COMPANY
PITTSFIELD, MASSACHUSETTS**

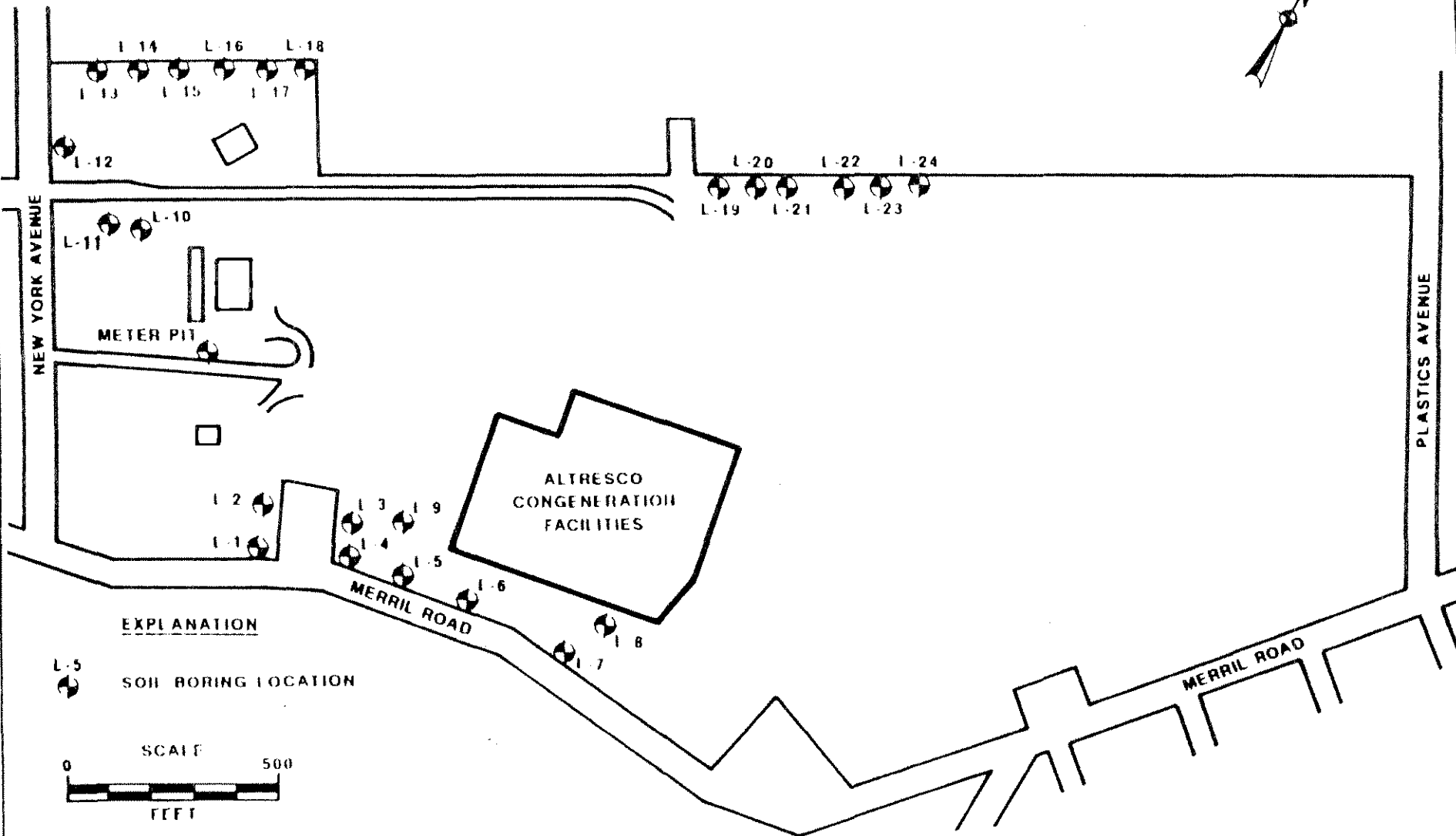
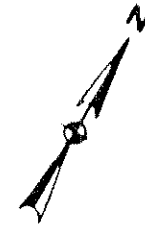

EXPLANATION

L-5
 SOIL BORING LOCATION

SCALE
0 500
FEET

SUBJECT:

**PITTSFIELD, G.E./ALTRESKO COGENERATION PLANT,
PITTSFIELD, MASSACHUSETTS**

FIGURE

1

SAMPLE/CORE LOG

BORING/WELL: L-17 PROJECT NO: NY05505 PAGE: 1 of 1

SITE LOCATION: GE Pittsfield/Altresco DRILLING STARTED: 4/13/90 DRILLING COMPLETED: 4/13/90

TOTAL DEPTH DRILLED: 6 ft. HOLE DIAMETER: 2 in. TYPE OF SAMPLE/CORING DEVICE: Split Spoon

LENGTH & DIAMETER OF CORING DEVICE: 2' x 2" SAMPLING INTERVAL: 2 ft.

LAND-SURFACE ELEVATION: () SURVEYED () ESTIMATED DATUM:

DRILLING FLUID USED: None DRILLING METHOD: HSA

DRILLING CONTRACTOR: Soil&Material Tsting DRILLER: Gilley HELPER: Joe

PREPARED BY: A. LaBarge HAMMER WEIGHT: 140 HAMMER DROP: 30 inches

Table with columns: SAMPLE DEPTH (FT BELOW LAND SURFACE), CORE RECVRY (FT), BLOW COUNTS PER 6 INCHES, SAMPLE/CORE DESCRIPTION. Rows include data for depths 0-2, 2-4, and 4-6 feet.



Laboratory Report

CLIENT BLASLAND & BOUCK ENGINEERS, P.C. JOB NO. 2887.026.517
 DESCRIPTION G.E. Pittsfield, Massachusetts

Date Analyzed: 4-16-90 DATE COLLECTED 4-12,13-90 DATE RECEIVED 4-16-90

Description	Sample #	PCB	PERCENT TOTAL SOLIDS	Aroclor
L1 0-2'	K0230	<0.6	82.	-
L1 2-4'	K0231	<0.6	88.	-
L2 0-2'	K0232	<0.6	80.	-
L2 2-4'	K0233	<0.6	78.	-
L3 0-2'	K0234	<0.6	84.	-
L3 2-4'	K0235	<0.6	87.	-
L4 0-2'	K0236	<0.5	93.	-
L4 2-4'	K0237	<0.6	82.	-
L5 0-2'	K0238	4.6	71.	1260
L5 2-4'	K0239	<0.6	77.	-
L6 0-2'	K0240	<0.6	82.	-
L6 2-4'	K0241	<0.6	87.	-
L7 0-2'	K0242	840.	79.	1254+1260
L7 2-4'	K0243	1000.	87.	1254+1260
L8 0-2'	K0244	1.8	88.	1260
L8 2-4'	K0245	33.	82.	1260
L8 4-6'	K0246	<0.6	85.	-
L9 0-2'	K0247	<0.7	74.	-
L9 2-4'	K0248	<0.6	82.	-

Comments:

Certification No.: (10155) Massachusetts-NY034

Units: mg/kg dry weight

Authorized: ART

Date: June 14, 1990



Laboratory Report

CLIENT BLASLAND & BOUCK ENGINEERS, P.C. JOB NO. 2887.026.517
 DESCRIPTION G.E., Pittsfield, Massachusetts

Date Analyzed: 4-16-90 DATE COLLECTED 4-12,13-90 DATE RECEIVED 4-16-90

Description	Sample #	PCB	PERCENT TOTAL SOLIDS	Aroclor
L10 0-2'	K0249	<0.6	82.	-
L10 2-4'	K0250	<0.6	80.	-
L11 0-2'	K0251	<0.6	86.	-
L12 0-2'	K0252	<0.6	82.	-
L12 2-4'	K0253	<0.6	80.	-
L13 0-2'	K0254	<0.6	87.	-
L14 0-2'	K0255	<0.6	85.	-
L14 2-4'	K0256	<0.6	87.	-
L15 0-2'	K0257	<0.6	79.	-
L15 2-4'	K0258	<0.6	90.	-
L16 0-2'	K0259	<0.6	83.	-
L16 2-4'	K0260	<0.6	88.	-
L17 0-2'	K0261	<0.6	88.	-
L17 2-4'	K0262	<0.6	91.	-
L17 4-6'	K0263	<0.5	95.	-
L18 0-2'	K0264	<0.6	85.	-
L18 2-5'	K0265	<0.6	81.	-
L19 2-4'	K0266	<0.5	93.	-
L19 2-4'	K0267	<0.6	83.	-

Comments:

Certification No.: (10155) Massachusetts-NY034
 Units: mg/kg dry weight

Authorized: ART
 Date: June 12, 1990



Laboratory Report

CLIENT BLASLAND & BOUCK ENGINEERS, P.C. JOB NO. 2887.026.517
 DESCRIPTION G.E., Pittsfield, Massachusetts

Date Analyzed: 4-16-90 DATE COLLECTED 4-12,13-90 DATE RECEIVED 4-16-90

Description	Sample #	PCB	PERCENT TOTAL SOLIDS	Aroclor
L19 4-6'	K0268	<0.6	80.	-
L20 0-2'	K0269	<0.6	81.	-
L20 2-4'	K0270	<0.6	84.	-
L21 0-2'	K0271	<0.6	82.	-
L21 2-4'	K0272	<0.6	84.	-
L22 0-2'	K0273	<0.6	84.	-
L22 204'	K0274	<0.6	84.	-
L23 0-2'	K0275	<0.6	85.	-
L23 2-4'	K0276	<0.6	89.	-
L24 0-2'	K0277	<0.6	85.	-
L24 2-4'	K0278	<0.5	93.	-

Comments:

Certification No.:(10155) Massachusetts-NY034

Units: mg/kg dry weight

Authorized: *[Signature]*



Laboratory Report

CLIENT BLASLAND & BOUCK ENGINEERS, P.C. JOB NO. 2887.026.517
 DESCRIPTION G.E. Pittsfield, Massachusetts
Altresco Metering Pit
 DATE COLLECTED 4-13-90 DATE RECEIVED 4-16-90

Description	Sample #	PCB	PERCENT TOTAL SOLIDS	Aroclor
Altresco Meter Pit 0-2'	K0279	34.	91.	1260
Altresco Meter Pit 2-6'	K0280	2.3	90.	1260
Altresco Meter Pit 6-10'	K0281	<0.6	78.	-

Comments:

Certification No.: (10155) Massachusetts-NY034

Units: mg/kg dry weight

Authorized: AAAT

Date: June 12, 1990

Project Number NY05505

Project Location GE PITTSFIELD MASS.

Laboratory OBG

Sampler(s) A. LABARGE



Kristen Franz Beger
Environmental Quality Engineer

Area Environmental & Facility Programs
100 Woodlawn Avenue Pittsfield, MA 01201
413 494 3737

SAMPLE IDENTITY	Date Sampled					TOTAL
L1 0-2'	4-12-90	1				1
L1 2-4'	4-12-90	1				1
L2 0-2'	4-12-90	1				1
L2 2-4'	4-12-90	1				1
L3 0-2'	4-12-90	1				1
L3 2-4'	4-12-90	1				1
L4 0-2'	4-12-90	1				1
L4 2-4'	4-12-90	1				1
L5 0-2'	4-12-90	1				1
L5 2-4'	4-12-90	1				1
L6 0-2'	4-12-90	1				1
L6 2-4'	4-12-90	1				1
L7 0-2'	4-12-90	1				1
L7 2-4'	4-12-90	1				1
L8 0-2'	4-12-90	1				1

Clean Glass Jar

(1) 3-5 day Turnover, please.
(2) Please send results directly to Kristen Beger

Thank-you,
A. Labarge

(3) Please ship cooler back to GE

SHIP TO:

General Electric Co.
East Street
Gate #15 - Bldg 17 Receiving
Pittsfield, MA 01201

Thank-you

No. of Bottles/Containers

(15)

ATTN: JS Nicholson, 11-336, X3588

Relinquished by: <u>Amy Labarge</u>	Organization: <u>Geraghty + Miller</u>	Date: <u>4/13/90</u> Time: <u>2:00 PM</u>	Seal Intact? Yes No N/A
Received by: _____	Organization: _____	Date: ___/___/___ Time: _____	Yes No N/A
Relinquished by: _____	Organization: _____	Date: ___/___/___ Time: _____	Seal Intact? Yes No N/A
Received by: _____	Organization: _____	Date: ___/___/___ Time: _____	Yes No N/A

Special Instructions/Remarks: _____

Delivery Method: In Person Common Carrier Federal Express Lab Courier Other

CHAIN-OF-CUSTODY RECORD

Project Number NY05305
 Project Location GE Pittsfield Mass
 Laboratory OBG
 Sampler(s) A. LABARGE

SAMPLE IDENTITY	Date Sampled	SAMPLE BOTTLE / CONTAINER DESCRIPTION								TOTAL
L8 2-4'	4-12-90	1								1
L8 4-6'	4-12-90	1								1
L9 0-2'	↓	1								1
L9 2-4'	↓	1								1
L10 0-2'	4-13-90	1								1
L10 2-4'	↓	1								1
L11 0-2'	↓	1								1
L11 2-4'										
L12 0-2'	↓	1								1
L12 2-4'	↓	1								1
L13 0-2'	↓	1								1
L13 2-4'										
L14 0-2'	↓	1								1
L14 2-4'	↓	1								1
L15 0-2'	↓	1								1

Clean Glass Jar

Total No. of Bottles/Containers 13

Relinquished by: <u>Amy LaBarge</u>	Organization: <u>Geraghty + Miller</u>	Date: <u>4/13/90</u> Time: <u>2:00 PM</u>	Seal Intact? Yes <input checked="" type="checkbox"/> No <input type="checkbox"/> N/A <input type="checkbox"/>
Received by: _____	Organization: _____	Date: <u>1/1</u> Time: _____	Seal Intact? Yes <input type="checkbox"/> No <input type="checkbox"/> N/A <input type="checkbox"/>
Relinquished by: _____	Organization: _____	Date: <u>1/1</u> Time: _____	Seal Intact? Yes <input type="checkbox"/> No <input type="checkbox"/> N/A <input type="checkbox"/>
Received by: _____	Organization: _____	Date: <u>1/1</u> Time: _____	Seal Intact? Yes <input type="checkbox"/> No <input type="checkbox"/> N/A <input type="checkbox"/>

Special Instructions/Remarks: _____

Delivery Method: In Person Common Carrier Lab Courier Other

CHAIN-OF-CUSTODY RECORD

Project Number NY05305
 Project Location GE Pittsfield Mass
 Laboratory OBG
 Sampler(s) A. LABARGE

SAMPLE BOTTLE / CONTAINER DESCRIPTION

SAMPLE IDENTITY	Date Sampled	SAMPLE BOTTLE / CONTAINER DESCRIPTION										TOTAL	
L-15 2-4	4-13-90	clean glass jar											1
L-16 0-2	↓												1
L-16 2-4	↓												1
L-17 0-2	↓												1
L-17 2-4	↓												1
L-17 4-6	↓												1
L-18 0-2	↓												1
L-18 2-4	↓												1
L-19 0-2	↓												1
L-19 2-4	↓												1
L-19 4-6	↓												1
L-20 0-2	4-12-90												1
L-20 2-4	↓												1
L-21 0-2	↓												1
L-21 2-4	↓												1

Total No. of Bottles/Containers 15

Relinquished by: <u>Amy LaBerge</u>	Organization: <u>Geroghty + Miller</u>	Date: <u>4/13/90</u> Time: <u>2:00 PM</u>	Seal Intact? <input checked="" type="radio"/> Yes <input type="radio"/> No <input type="radio"/> N/A
Received by: _____	Organization: _____	Date: <u> / / </u> Time: _____	Seal Intact? <input type="radio"/> Yes <input type="radio"/> No <input type="radio"/> N/A
Relinquished by: _____	Organization: _____	Date: <u> / / </u> Time: _____	Seal Intact? <input type="radio"/> Yes <input type="radio"/> No <input type="radio"/> N/A
Received by: _____	Organization: _____	Date: <u> / / </u> Time: _____	Seal Intact? <input type="radio"/> Yes <input type="radio"/> No <input type="radio"/> N/A

Special Instructions/Remarks: _____

Delivery Method: In Person Common Carrier Lab Courier Other

CHAIN-OF-CUSTODY RECORD

Project Number NY05505
 Project Location GE Pittsfield Mass
 Laboratory OB6
 Sampler(s) A. LABARGE

SAMPLE BOTTLE / CONTAINER DESCRIPTION

Clean Glass Jar

SAMPLE IDENTITY	Date Sampled										TOTAL
L-22 0-2'	4-12-90										
L-22 2-4'	↓										
L-23 0-2'											
L-23 2-4'											
L-24 0-2'											
L-24 2-4'											

Total No. of Bottles/Containers

6

Relinquished by: <u>Amy LaBarge</u>	Organization: <u>Geraghty + Miller</u>	Date: <u>4/13/90</u>	Time: <u>2:00 PM</u>	Seal Intact? Yes No N/A
Received by: _____	Organization: _____	Date: <u>1/1</u>	Time: _____	Yes No N/A
Relinquished by: _____	Organization: _____	Date: <u>1/1</u>	Time: _____	Seal Intact? Yes No N/A
Received by: _____	Organization: _____	Date: <u>1/1</u>	Time: _____	Yes No N/A

Special Instructions/Remarks: _____

Delivery Method: In Person Common Carrier Lab Courier Other

SPECIFY

SPECIFY

CASE FILE

Survey: GE Pittsfield Date Collected: 4-17-90

Sampler: G. Miller Date Received: 4-16-90

Client Name and Ref. #: Blasland & Bouck

Laboratory Number: 2887.026.57

Condition of Shipment: Sample #5, 2-4' 4-12-90 was broken upon arrival. Transferred to another container in lab. One container away for 4-13 & 4-11

Archive? If so how long? NO

Signed: [Signature]
Sample Coordinator

Disposal Procedure*: PCB contaminated samples will be disposed of as PCB waste

Signed: [Signature]
Date: 4-24-90

* The routine disposal procedure for non-hazardous samples is to dispose of the samples 4 weeks after a typed report is signed and mailed to the client. Water samples are filtered through carbon to the sanitary sewer. Solid samples are sent to a sanitary landfill.



GERAGHTY & MILLER, INC.

Ground-Water Services

CHAIN-OF-CUSTODY RECORD

Project Number NY05505

Project Location 6E PITTSFIELD MASS

Laboratory DB6

Sampler(s) A. LABARGE

SAMPLE BOTTLE / CONTAINER DESCRIPTION

Clean Glass Jar

SAMPLE IDENTITY	Date Sampled	SAMPLE BOTTLE / CONTAINER DESCRIPTION								TOTAL
(Altresco Meter Pit)	4-13-90									
0-2"	↓	1								1
2-6"	↓	1								1
6-10"	↓	1								1
Please send these results for the Altresco Metering Pit on a separate Report. Send to Kristen Bigon also.										

Total No. of Bottles/Containers 3

Relinquished by: <u>Amy Labarge</u>	Organization: <u>Geraghty + Miller</u>	Date: <u>4/13/90</u>	Time: <u>2:00 PM</u>	Seal Intact? Yes No N/A
Received by: _____	Organization: _____	Date: / /	Time: _____	Yes No N/A
Relinquished by: _____	Organization: _____	Date: / /	Time: _____	Seal Intact? Yes No N/A
Received by: _____	Organization: _____	Date: / /	Time: _____	Yes No N/A

Special Instructions/Remarks: _____

Delivery Method: In Person Common Carrier Fed Ex Lab Courier Other

CASE FILE

Survey: CE Pittsfield-Altresco Date Collected: 4-13-90

Sampler: A. Laberge Date Received: 4-16-90

Client Name and Ref. # : Blastrand & Bouch

Laboratory Number: 2887.026.517

Condition of Shipment: good

Archive? If so how long ? NO

Signed: [Signature]
Sample Coordinator

Disposal Procedure* : PCB contaminated soils will
be disposed of as PCB waste

Signed: [Signature]
Date: 4-24-90

* The routine disposal procedure for non-hazardous samples is to dispose of the samples 4 weeks after a typed report is signed and mailed to the client. Water samples are filtered through carbon to the sanitary sewer. Solid samples are sent to a sanitary landfill.

CASE FILE

Survey: GE Pittsfield-ALFRESCO Date Collected: 4-13-90

Sampler: A. Laberge Date Received: 4-16-90

Client Name and Ref. # : Blastrand & Bouch

Laboratory Number: 2887.026.517

Condition of Shipment: good

Archive? If so how long ? NO

Signed: [Signature]
Sample Coordinator

Disposal Procedure* : PCB contaminated soils will
be disposed of as PCB waste

Signed: [Signature]
Date: 4-24-90

* The routine disposal procedure for non-hazardous samples is to dispose of the samples 4 weeks after a typed report is signed and mailed to the client. Water samples are filtered through carbon to the sanitary sewer. Solid samples are sent to a sanitary landfill.

APPENDIX J
SURFACE SOIL SAMPLE ANALYTICAL REPORT

ELASLAND & BOUCK ENGINEERS P.C.

SUBJECT: Hill 78 Superficial Soil Sampling

PROJECT NO: 101-75-18

BY: S E Melbourne

DATE: 8-26-91

REQUEST FOR SAMPLING

DATE: 8-23-91

INITIATOR: Mark Phillips

BLDG. LOCATION: Hill 78

CONTACT PERSON: Mark Phillips

EXT: 3027

ITEM DESCRIPTION:

1.) Soil

NOTES:

The following sampling criteria was implemented at the request of Mark Phillips (GE):

- 1.) Superficial (0"-6") soil samples to be taken at locations selected by Mark Phillips (GE).
- 2.) Soil samples to be analyzed for PCB's Method 8080.

Sampling Program was conducted on a discrete grab sample basis.

BLASLAND AND BOUCK ENGINEERS P.C.

To: Files
From: Bruce Eulian
Re: Hill 78 Superficial Soil Sampling

Date: 8-27-91
File No: 101-75-18
cc: Grant Bowman (GE)
cc: Mark Phillips (GE)

The following is a summary of the sample results for the PCB sampling program conducted at Hill 78 on 8-23-91. A drawing showing the sample location is attached (see figure 1). An analytical Report provided by OGS Laboratories has also been included.

PCB SAMPLING RESULTS METHOD 8080

LAB ID	TOTAL PCB PPM	SAMPLE LOCATION	SAMPLE MATERIAL	SAMPLE TYPE	SAMPLE DEPTH
HILL78-SUP-C1	2.4	1	SOIL	DISCRETE-GRAB	0"-6"
HILL78-SUP-C2	9.7	2	SOIL	DISCRETE-GRAB	0"-6"
HILL78-SUP-C3	<0.6	3	SOIL	DISCRETE-GRAB	0"-6"
HILL78-SUP-C4	<0.6	4	SOIL	DISCRETE-GRAB	0"-6"
HILL78-SUP-C5	<0.6	5	SOIL	DISCRETE-GRAB	0"-6"
HILL78-SUP-C6	3.9	6	SOIL	DISCRETE-GRAB	0"-6"
HILL78-SUP-C7	2.6	7	SOIL	DISCRETE-GRAB	0"-6"
HILL78-SUP-C8	<0.7	8	SOIL	DISCRETE-GRAB	0"-6"
HILL78-SUP-C9	1.1	9	SOIL	DISCRETE-GRAB	0"-6"
HILL78-SUP-C10	1.3	10	SOIL	DISCRETE-GRAB	0"-6"

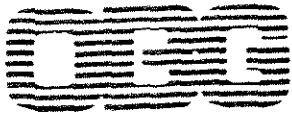

LABORATORIES, INC.

Laboratory Report

CLIENT BLASLAND & BOUCK ENGINEERS, INC.

JOB NO. 2887.026.517

DESCRIPTION Hill 78 Superficial Soil Sampling

B & B # 101.75.18

MATRIX: Solid

Date Analyzed 8-24-91

DATE COLLECTED 8-23-91

DATE RECEIVED 8-24-91

	Sample #	PCB	Aroclor	PERCENT TOTAL SOLIDS
HILL 78-SUP-C1	N0753	2.4	1260	88.
HILL 78-SUP-C2	N0754	9.7	1260	93.
HILL 78-SUP-C3	N0755	<0.6	-	92.
HILL 78-SUP-C4	N0756	<0.6	-	95.
HILL 78-SUP-C5	N0757	<0.6	-	94.
HILL 78-SUP-C6	N0758	3.8	1260	93.
HILL 78-SUP-C7	N0759	2.6	1260	90.
HILL 78-SUP-C8	N0760	<0.7	-	81.
HILL 78-SUP-C9	N0761	1.1	1260	96.
HILL 78-SUP-C10	N0762	1.3	1260	94.

Comments:

Certification No.: NY034

Units: mg/kg dry weight

Authorized: 

Date: August 26, 1991

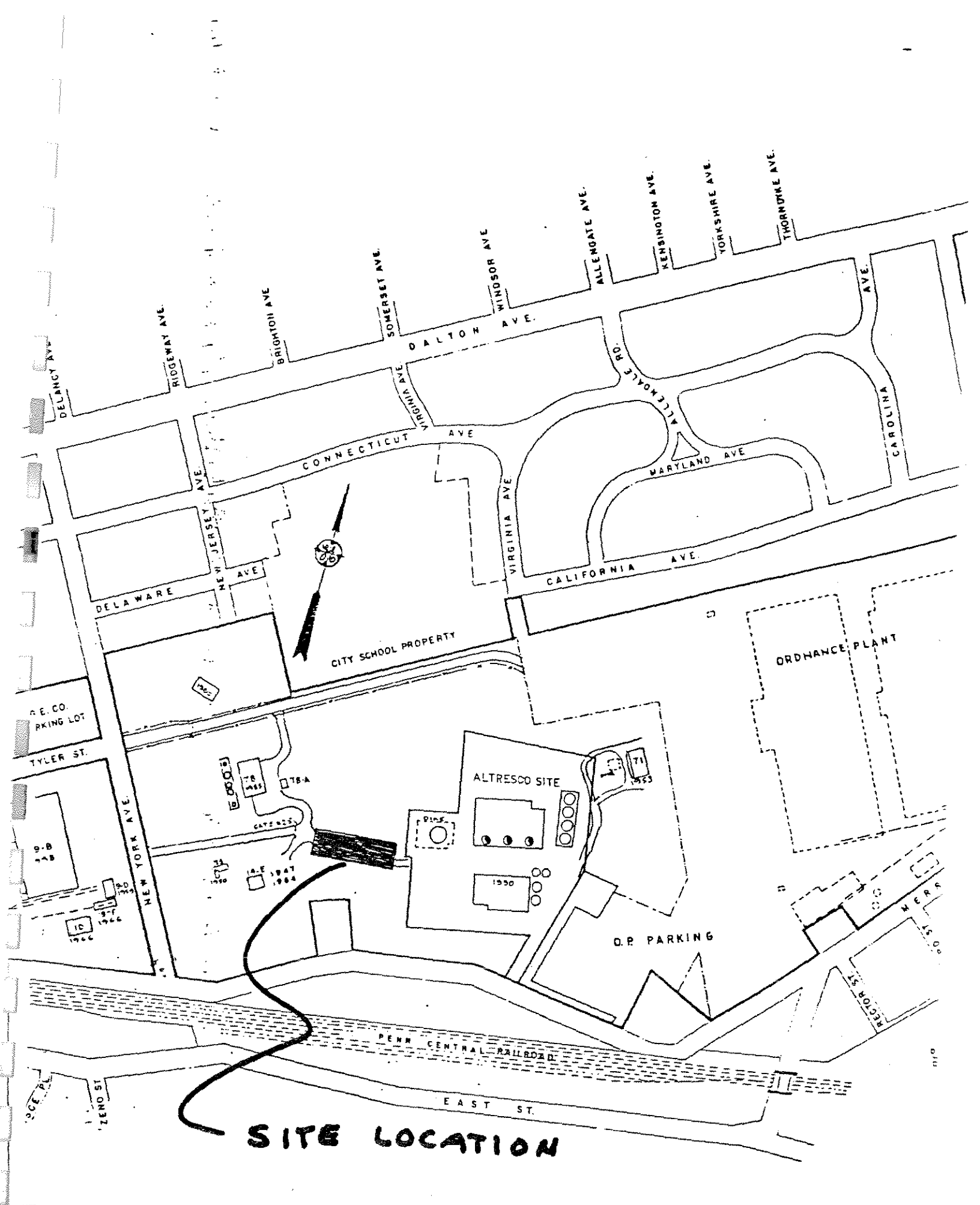

SITE LOCATION



BLASLAND & BOUCK ENGINEERS, P.C.
 6723 Tow Path Road, Box 66, Syracuse, New York 13214
 (315) 446-9120

CHAIN OF CUSTODY RECORD

PROJECT NO.		PROJECT NAME							NO. OF CONTAINERS	PCB METHOD 8080					REMARKS
101.75-18		HILL 78 SUPERFICIAL SOIL SAMPLING													
LAB ID	CUSTODY TAPE NUMBER	DATE	TIME	COMP.	GRAB	SAMPLE TYPE									
						SOLID	WIPE	WATER							
HILL 78-SUP-C1		8-23	12:30		X	X			1	X				SEND RESULTS TO:	
HILL 78-SUP-C2		8-23	12:45		X	X			1	X				BLASLAND & BOUCK ENG.	
HILL 78-SUP-C3		8-23	1300		X	X			1	X				% G.E. POWER TRANSFORMER	
HILL 78-SUP-C4		8-23	1315		X	X			1	X				MAILCODE D-32	
HILL 78-SUP-C5		8-23	1330		X	X			1	X				100 WOODLAWN AVE.	
HILL 78-SUP-C6		8-23	1345		X	X			1	X				PITTSFIELD, MA.	
HILL 78-SUP-C7		8-23	1400		X	X			1	X				01201	
HILL 78-SUP-C8		8-23	1415		X	X			1	X					
HILL 78-SUP-C9		8-23	1430		X	X			1	X				CC: ROBERT BHOADES	
HILL 78-SUP-C10		8-23	1445		X	X			1	X				% BLASLAND & BOUCK ENG.	
														6723 TOWPATH RD.	
														SYRACUSE, N.Y. 13214	
SAMPLED BY: (SIGNATURE)		DATE/TIME		RECEIVED BY: (SIGNATURE)				RELINQUISHED BY: (SIGNATURE)				DATE/TIME		RECEIVED BY: (SIGNATURE)	
<i>Bruce Eulian</i>		8-23-91 1230 TO 1445													
RELINQUISHED BY: (SIGNATURE)		DATE/TIME		RECEIVED BY: (SIGNATURE)				RELINQUISHED BY: (SIGNATURE)				DATE/TIME		RECEIVED BY: (SIGNATURE)	
RELINQUISHED BY: (SIGNATURE)		DATE/TIME		RECEIVED FOR LABORATORY BY: (SIGNATURE)				DATE/TIME		REMARKS TO: OBG LAB SYRACUSE, N.Y.					
										RUSH 24 HR. TURN AROUND					

APPENDIX K
PRELIMINARY ASSESSMENT REPORT

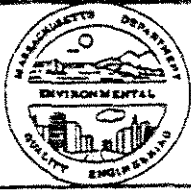

Commonwealth of Massachusetts Department of Environmental Quality Engineering

Potential Oil/Hazardous Material Release Site
PRELIMINARY ASSESSMENT REPORT

For DEQE Use Only

Case No. _____
File Name _____
Date Listed _____
Disposition _____

L PROPERTY NAME AND LOCATION (See Supplementary Instructions)

Property Name: Hill 78 Area; MCP Site 1-0714
Address: 100 Woodlawn Avenue
Pittsfield, Massachusetts

UTM Coordinates:
N 4,701,500 M
E 645,500 M

Municipality: Pittsfield Zip Code: 01201 USGS Quad(s): Pittsfield East 1988

Latitude/Longitude
42 27 10 N
73 13 45 W

II OWNERS/OPERATORS

Present Owner: Address: Contact: <u>Grant Bowman/Mark Phillips</u> Tel. <u>(413)494-2700</u>	General Electric Company 100 Woodlawn Avenue Pittsfield, Massachusetts 01201	Date Acquired: <u>1927</u>	Specific Property Use/Activity: SIC # _____ <input type="checkbox"/> Active <input type="checkbox"/> Inactive
Present Operator: Address: Contact: <u>Grant Bowman/Mark Phillips</u> Tel. <u>(413)494-2700</u>	General Electric Company 100 Woodlawn Avenue Pittsfield, Massachusetts 01201	Date Started: <u>1940s</u>	Specific Property Use/Activity: <u>Fill and storage area</u> SIC # _____ <input type="checkbox"/> Active <input checked="" type="checkbox"/> Inactive
Previous Owner: Address: Tel. - -	Industrial Development Company (no longer exists)	From/To Dates	Specific Property Use/Activity SIC # _____
Previous Operator: Address: Tel. - -		From/To Dates	Specific Property Use/Activity SIC # _____

Additional Owner/Operator Information is: _____ Attached _____ Unknown Not Pertinent

III GENERAL PROPERTY/AREA INFORMATION

Site Locus Map Attached?

Property/Area Use *	Property Present	Property Past	Surrounding Area	Check if property is or ever was a known:
Industrial	<u>X</u>	<u>X</u>	<u>X</u>	<u>X</u> Refuse/Waste Disposal Area
Commercial	---	---	<u>X</u>	--- Gasoline (Service) Station
Residential	---	---	---	--- Fuel Storage Depot
Agricultural	---	---	---	--- Industrial Manufacturing Facility
Undeveloped	---	---	---	--- Check if Property is Planned for Development

IV. REVIEW OF AVAILABLE RECORDS/INFORMATION

Municipal: Date Reviewed 4/25/91 By A. LaBarge Of Geraghty & Miller, Inc.
Information Source(s): Tax Assessor, Deed Registry, Planning/Zoning Board, Public Works, and
Contact Person(s): Building Inspector. Telephone: (413)499-9340

State: Date Reviewed 4/29/91 By A. LaBarge Of Geraghty & Miller, Inc.
Information Source(s): DEP Water Supply Atlas, Reported Spills
Contact Person(s): _____ Telephone: (413)784-1100

Owner/Operator: Date Reviewed 5/16/91 By A. LaBarge Of Geraghty & Miller, Inc.
Information Source(s): Tom Bednarz, Mark Phillips, GE EEO Group
Contact Person(s): Tom Bednarz, Mark Phillips Telephone: (413)494-3027

Other: Date Reviewed _____ By _____ Of _____
Information Source(s): _____
Contact Person(s): _____ Telephone: _____

Additional Information/Information Sources are attached: Yes No.

IV. SURVEY OF AVAILABLE RECORDS/INFORMATION (Continued.)

Based upon records and available information, have petroleum products or hazardous materials been used, treated, stored, or disposed of, on the property?

Yes No Petroleum Hazardous Materials

Underground Storage Tanks: ¹²	Records/Evidence of Present/Former Use: <input type="checkbox"/> Yes <input checked="" type="checkbox"/> No				
Indicate Number of Tanks:	Gasoline	Fuel Oil	Waste/Other Oil	Hazardous Materials	Unknown
Presently On-site	_____	_____	_____	_____	_____
Removed	_____	_____	_____	_____	_____
With Capacity 1100 Gallons	_____	_____	_____	_____	_____
Over 10 Years Old	_____	_____	_____	_____	_____
Total Number:	_____	_____	_____	_____	_____

Wastewater: ¹³ Generated? Yes No Unknown
 Composition: Sanitary Industrial
 Disposal: Municipal Sewer On-site Other
 Present: Yes No Unknown
 Past: Yes No Unknown
 Sanitary: Sanitary Industrial
 Municipal Sewer: Municipal Sewer On-site Other

Comments: _____

Is there currently an on-site water supply well? Yes No Unknown. Active? Yes No.
 Other existing means for sampling groundwater? Yes No

Industrial Cooling Water

Indicate Present or Past Federal/State Environmental Permits/Regulations at the Property.
 N.P.D.E.S. Groundwater Discharge R.C.R.A. Generator R.C.R.A. TSD Air Quality Other
 Comments: TSCA permitted storage facility.

Is/are there any record(s) of Criminal, Civil, or Administrative Actions, at the property due to (alleged) violations of environmental statute or regulation? Yes No
 Comments: None specific to this site.

V. PROPERTY RECONNAISSANCE

Property Reconnaissance by Owner/Operator/Consultant ¹⁴ (Circle one.)
 Date 9-4-91 By Mark Phillips of General Electric Company

Evidence of a Release of Oil or Hazardous Materials? Yes No Potential

If Yes/Potential, Based upon: visual olfactory analytical/screening

Comments: Considerable soil borings and Phase I assessment indicates material non-classified as hazardous has been deposited in the area. No visual or olfactory signs of release.

FOR DEQE USE ONLY:

On-site Reconnaissance Off-site Reconnaissance By EPA/DEQE/Contractor: (Circle one.)

Date _____ By _____ Of _____

Evidence of a Release of Oil or Hazardous Materials? Yes No Potential

Comments: _____

VI. PRELIMINARY ASSESSMENT SUMMARY/REPORTING MATRIX

Based upon a review and evaluation of available records, information, and field observations, indicate and summarize applicable property conditions. Abbreviations and table headings are explained at the bottom of the page; additional guidance is contained in direction section. Please note that responses are mandatory in shaded columns.

SOURCE	Past/Present Existence ¹⁴		Test Data Available ¹⁵		Evidence of OHM Contamination/Release ¹⁷		COMMENTS ¹⁸				
	Yes	No	Information Source (f)	Yes	No	Describe (g)		Rec.	Obs.	Test	None
On-Site (Non-Liquid) Waste Disposal (a)	<input checked="" type="checkbox"/>	<input type="checkbox"/>	Borings	<input checked="" type="checkbox"/>	<input type="checkbox"/>	Boring Logs and Laboratory Data	<input checked="" type="checkbox"/>	<input checked="" type="checkbox"/>	<input checked="" type="checkbox"/>	<input type="checkbox"/>	See Phase I Report Sections 3.0, 4.0, 7.0)
Surface OHM Discharge or Spillage	<input checked="" type="checkbox"/>	<input type="checkbox"/>	Records	<input type="checkbox"/>	<input checked="" type="checkbox"/>		<input type="checkbox"/>	<input type="checkbox"/>	<input type="checkbox"/>	<input checked="" type="checkbox"/>	Building 72 above-ground oil storage tank
Surface Wastewater Discharge (b)	<input type="checkbox"/>	<input type="checkbox"/>		<input type="checkbox"/>	<input checked="" type="checkbox"/>		<input type="checkbox"/>	<input type="checkbox"/>	<input type="checkbox"/>	<input checked="" type="checkbox"/>	
Subsurface OHM Discharge (c)	<input type="checkbox"/>	<input type="checkbox"/>	Records	<input type="checkbox"/>	<input checked="" type="checkbox"/>		<input type="checkbox"/>	<input type="checkbox"/>	<input type="checkbox"/>	<input checked="" type="checkbox"/>	Building 71 storm water drain line.
Subsurface Wastewater Discharge (d)	<input type="checkbox"/>	<input type="checkbox"/>		<input type="checkbox"/>	<input checked="" type="checkbox"/>		<input type="checkbox"/>	<input type="checkbox"/>	<input type="checkbox"/>	<input type="checkbox"/>	
Underground Storage Tank(s) - Oil - (e)	<input type="checkbox"/>	<input type="checkbox"/>		<input type="checkbox"/>	<input checked="" type="checkbox"/>		<input type="checkbox"/>	<input type="checkbox"/>	<input type="checkbox"/>	<input type="checkbox"/>	
Underground Storage Tank(s) - Haz. Materials -	<input type="checkbox"/>	<input type="checkbox"/>		<input type="checkbox"/>	<input checked="" type="checkbox"/>		<input type="checkbox"/>	<input type="checkbox"/>	<input type="checkbox"/>	<input type="checkbox"/>	
Above-Ground Oil/Haz. Material Storage Tank(s)	<input checked="" type="checkbox"/>	<input type="checkbox"/>		<input type="checkbox"/>	<input checked="" type="checkbox"/>		<input type="checkbox"/>	<input type="checkbox"/>	<input type="checkbox"/>	<input checked="" type="checkbox"/>	Building 72 above-ground oil storage tank
Other:	<input type="checkbox"/>	<input type="checkbox"/>		<input type="checkbox"/>	<input checked="" type="checkbox"/>		<input type="checkbox"/>	<input type="checkbox"/>	<input type="checkbox"/>	<input checked="" type="checkbox"/>	
Unknown Source but Evidence of Contamination	<input type="checkbox"/>	<input type="checkbox"/>		<input type="checkbox"/>	<input checked="" type="checkbox"/>		<input type="checkbox"/>	<input type="checkbox"/>	<input type="checkbox"/>	<input checked="" type="checkbox"/>	

FOOTNOTES: (a) includes refuse, demolition wastes, sludges, hazardous wastes; (b) includes domestic or industrial sewage, surface impoundments; (c) via dry wells, leach fields, injection wells, etc.; (d) includes domestic or industrial sewage leach fields/pits; (e) note: waste oil is considered a "hazardous material"; (f) records, field observation, etc.; (g) includes tank testing data, geophysical data, analytical data, etc.

ABBREVIATIONS: Rec = Records; Obs = Observations; OHM = Oil or Hazardous Material

ADDITIONAL COMMENTS: ¹⁸

Property Access: ¹⁹ Restricted Unrestricted Partially Restricted

Property Ownership: Private Governmental Military

VII. CONCLUSIONS AND CERTIFICATIONS

Based upon all available information and data, pursuant to MGL Chapter 21E, is there evidence that a release of oil or hazardous materials has or is occurring at the property? Yes No Unknown at this time

Do property conditions constitute a threat of release? Yes No Potential

If either of above is "Yes", are immediate site actions necessary to abate an imminent hazard to public health, safety, welfare, or the environment, due to:

- Proximity to known potable water supplies? Yes No
- Potential for direct human contact and exposure? Yes No
- Potential for fire or explosion? Yes No
- Proximity to fisheries/critical habitats? Yes No
- Other: STM cap completed August 1991 Yes No

If a release has been confirmed, are immediate actions necessary to initiate abatement, containment, or recovery actions, in order to avoid a situation where a delay in remedial actions will substantially decrease the efficiency and/or degree of ultimate cleanup?

Yes No

Have remedial actions already been taken at the site? Yes No

NOTE: If immediate actions are needed, or if remedial actions have already been taken at the site, append complete details on nature of problem and proposed/completed site actions.

STM cap described in Phase I report (Section 9.0)

Owner/Operator/Private Party (Circle one.)
 Name Grant Bowman
 Title Manager Environmental Engineering
 Company General Electric Company
 Date 9-5-91
 Property Affiliation Employee of owner

Professional Environmental Consultant
 Name Marc W. Sanford
 Title Project Scientist
 Firm Geraghty & Miller, Inc.
 Date 9-5-91

Additional information attached to Form Phase I Report

Indicate Name(s) of Environmental Assessment Report(s) prepared for Property: See Phase I - Limited Site Investigation/Current Assessment Summary Report

If Form completed by Private Party and/or Professional Environmental Consultant, please sign:

I hereby certify that the information furnished in and with this Form, to the best of my knowledge, is true, accurate, and complete.

Signature: Mark C. Phillips
 (Owner/Operator/Private Party)

Signature: Marc W. Sanford
 (Consultant)

VIII. DISPOSITION OF CASE

FOR DEQE USE ONLY:

Form completed by: PRP/Consultant/DEQE/DEQE Contractor/Other (Circle one.) Date Received: _____

If not compiled by DEQE, is provided information: Adequate Insufficient Inaccurate

Conclusions: No Evidence of Release Release Confirmed Potential Release - Further Investigation Required

Disposition of Case: No Action Re-do P.A. Perform SL Perform IRM Other

Enforcement Position: N.A. Send N.O.R. N.O.R. sent _____ Other

Comments: _____

DEQE STAFF: _____ TITLE: _____
 SIGNATURE: _____ DATE: _____

APPENDIX L
INTERIM SITE CLASSIFICATION FORM

INTERIM SITE CLASSIFICATION FORM

DISPOSAL SITE NAME Hill 78 Area
 SITE ID NUMBER 1-0714
 STREET 100 Woodlawn Avenue
 CITY/TOWN Pittsfield STATE MA ZIP CODE 01201

Completed by:
 Name: Mark Phillips Company: General Electric
 Street: 100 Woodlawn Avenue City/Town: Pittsfield
 State: Massachusetts Zip Code: 01201

CLASSIFICATION SUMMARY

Complete following pages of form and summarize classification below:

Criterion	Met	Not Met	Insufficient Information
1	<input type="checkbox"/>	<input checked="" type="checkbox"/>	<input type="checkbox"/>
2	<input type="checkbox"/>	<input checked="" type="checkbox"/>	<input type="checkbox"/>
3	<input type="checkbox"/>	<input checked="" type="checkbox"/>	<input type="checkbox"/>
4	<input type="checkbox"/>	<input checked="" type="checkbox"/>	<input type="checkbox"/>
5	<input type="checkbox"/>	<input checked="" type="checkbox"/>	<input type="checkbox"/>
6	<input type="checkbox"/>	<input checked="" type="checkbox"/>	<input type="checkbox"/>
7	<input type="checkbox"/>	<input type="checkbox"/>	<input checked="" type="checkbox"/>
8	<input type="checkbox"/>	<input checked="" type="checkbox"/>	<input type="checkbox"/>
9	<input type="checkbox"/>	<input checked="" type="checkbox"/>	<input type="checkbox"/>

Recommended Site Classification:

Priority
 Non-Priority
 Insufficient Information to Classify

Pending review of air monitoring results

Signature: Mark C Phillips Date: 9/6/91

FOR DEQE USE

	DEQE Concurrence		Comment
	Yes	No	
1	<input type="checkbox"/>	<input type="checkbox"/>	
2	<input type="checkbox"/>	<input type="checkbox"/>	
3	<input type="checkbox"/>	<input type="checkbox"/>	
4	<input type="checkbox"/>	<input type="checkbox"/>	
5	<input type="checkbox"/>	<input type="checkbox"/>	
6	<input type="checkbox"/>	<input type="checkbox"/>	
7	<input type="checkbox"/>	<input type="checkbox"/>	
8	<input type="checkbox"/>	<input type="checkbox"/>	
9	<input type="checkbox"/>	<input type="checkbox"/>	

Department's Determination on Site Classification

Priority
 Non-Priority
 Insufficient Information to Classify

Approved by: _____

Title: _____

Date: _____

INTERIM SITE CLASSIFICATION

Note: Check appropriate box for each criterion indicating whether a criterion is met or not met or if information is inadequate to determine whether a criterion is met. Only one of these three boxes should be checked for each criterion. A disposal site cannot be classified as a non-priority disposal site if information is inadequate for any criterion.

Met **Not Met**

1. Criterion 1 is met if conditions at the disposal site provide the opportunity for direct contact with oil or hazardous materials via open lagoons, drum storage areas and sludges, or

If conditions at the disposal site provide the opportunity for direct contact with surface oil or hazardous materials and there is evidence of, or data that indicate, surface contamination at concentrations that could adversely affect human or environmental receptors.

Supporting Information and Source: As noted in Section 3.5 of GE's Phase I Report, the Hill 78 Area contains a RCRA-permitted hazardous waste storage area and a TSCA-permitted PCB drum storage area. These storage areas are locked and access is strictly controlled to prevent direct contact with the hazardous materials stored therein. Moreover, given the data on the concentrations of PCBs and other hazardous materials in the remaining surficial soil and surface water at the site, as well as the access-restricted nature of the site, the evidence does not indicate any realistic opportunity for direct contact with surface materials at concentrations that would adversely affect human health or the environment. See **Additional information is required to determine if Criterion 1 is met.** Sections 9.2 and 7.5 of Phase I Report.

Describe:

Met Not Met

2. Criterion 2 is met if there is evidence of or data that indicate the presence of uncontained migrating oil or hazardous materials which exist as a separate phase in groundwater or surface water.

Supporting Information and Source:

There is no evidence of uncontained, separate-phase, migrating oil or hazardous materials in the groundwater or surface water at this site. See Sections 5.1, 5.2, 7.4, and 7.5 of Phase I Report.

Additional information is required to determine if Criterion 2 is met.
Describe:

Met Not Met

3. Criterion 3 is met if there are data that indicate groundwater contamination with oil or hazardous materials at levels exceeding state or federal drinking water standards/guidelines (or detectable levels of contaminants for which there are not state/federal standards or guidelines) and

the data is based on samples taken from a location that:

- i. is within 2640 feet of a municipal water supply well(s), or
No
- ii. is within a mapped cone of influence of a municipal water supply well(s), or
No
- iii. is a private water supply well(s) or potentially affects a private water supply well,
No

Met Not Met

4. Criterion 4 is met if there is evidence of, or data that indicate that, a release of oil or hazardous materials at or from the disposal site into surface water has occurred and that the release is upstream of a potable surface water supply intake structure or of the recharge area of a municipal well(s),

unless there are data that indicate:

- i. that a hydrogeologic connection between the release of oil or hazardous materials into surface water and the recharge area does not exist, or
- ii. that concentrations of oil or hazardous materials at the surface water supply intake or the municipal well have not and are not likely to exceed State or Federal drinking water standard/guidelines, or
- iii. that concentrations of oil or hazardous materials at the surface water supply intake or the municipal well(s), for which there are no drinking water standards or guidelines, are not and are not likely to be harmful to those drinking the water.

Supporting Information and Source: There is no evidence of releases of oil or hazardous materials at or from this site into surface waters upstream of a potable supply intake. Neither the on-site drainage swale nor the Housatonic River in the vicinity of the Pittsfield facility is used as a source of potable water supply. See Section 2.6 of Phase I Report.

Additional information is required to determine if Criterion 4 is met.
Describe:

unless there are data which indicate:

- i. that a hydrogeologic connection does not exist between the groundwater containing oil or hazardous materials and the municipal water supply well, or
No
- ii. that the identified concentrations of oil or hazardous materials, for which there are no drinking water standards or guidelines, are not and are not likely to be harmful to those drinking the water, or
No
- iii. that the oil or hazardous materials have not migrated to and are not likely to migrate to public or private water supply well(s).
No

Supporting Information and Source:

As noted in Sections 2.6 and 12.2 of GE's Phase I Report, there are no public or private drinking water supply wells within 0.5 miles of the site or potentially affected by ground-water conditions at the site.

Additional information is required to determine if Criterion 3 is met.
Describe:

Met **Not Met**

5. Criterion 5 is met if there is evidence of, or data that indicate that, a release of oil or hazardous materials at or from the disposal site to surface water has resulted or could result in a concentration which exceeds Ambient Water Quality Criteria for the protection of aquatic life or human health.

Supporting Information and Source:

There is no evidence of releases of oil or hazardous materials at or from the site to surface water. As discussed in Section 2.2 of GE's Phase I Report, the water in the on-site drainage swale flows from a pipe to which there are no contributions from GE property.

Additional information is required to determine if Criterion 5 is met.
Describe:

Met **Not Met**

6. Criterion 6 is met if there is evidence of, or data that indicate that, the disposal site poses a threat of fire or explosion.

Supporting Information and Source:

The types of materials disposed of at the site in the Hill 78 landfill (demolition and construction debris, excavated soils, and other non-volatile solid wastes) do not indicate a potential threat of fire or explosion. See Section 3.2 of Phase I Report.

Additional information is required to determine if Criterion 6 is met.
Describe:

Met **Not Met**

7. Criterion 7 is met if there is evidence, or data that indicate that there are or there could be air emissions at or from the disposal site which could adversely impact human or environmental receptors.

Supporting Information and Source:

Additional information is required to determine if Criterion 7 is met.

Describe: A year long Air Monitoring Program to measure PCB air emissions from the Hill 78 Area was initiated August 22, 1991. See Section 6.5 of Phase I Report. The Hill 78 landfill has been capped. See Section 9.1 of Phase I Report.

Met **Not Met**

8. Criterion 8 is met if there is evidence of, or data that indicate that, releases of oil or hazardous materials at or from the disposal site have affected or could affect the human food chain.

Supporting Information and Source:

The site is part of an industrial complex. There are no gardens at this site and no evidence of any releases from this site that have affected any gardens in the vicinity. Moreover, there is no evidence that releases from this site have impacted the Housatonic River so as to effect any food chain organisms in the river.

Additional information is required to determine if Criterion 8 is met.

Describe:

Met **Not Met**

9. Criterion 9 is met if there are data or any other information that indicate that the disposal site may pose a significant or otherwise unacceptable risk of harm to health, safety, public welfare, or to the environment if left in its present state for several years. Note: This criterion is to be used only if none of the previous eight criteria were met, and no additional information is required.

Supporting Information and Source:

Since the site is access-restricted and will remain so for the foreseeable future, the data does not indicate a significant or otherwise unacceptable risk of harm to health, safety, public welfare or the environment if this site is left in its present state for several years. See Phase I Report generally. As discussed in Section 9.1 of the Phase I Report, the Hill 78 landfill has been capped.