

9.2

HOUSATONIC RIVER BASIN

LEE-LENOX, MASSACHUSETTS

RECEIVED
NOV 19 1979

WOODS POND (VALLEY MILL) DAM

MA 00731

Western Region
Department of Environmental
Quality Engineering

RCRA RECORDS CENTER
FACILITY G. E. Pittsford
I.D. NO. MA0002089095
FILE LOC. 501
OTHER 213354

PHASE I INSPECTION REPORT
NATIONAL DAM INSPECTION PROGRAM

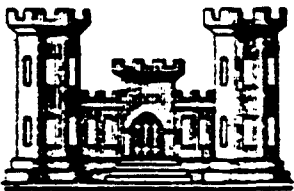

DEPARTMENT OF THE ARMY
NEW ENGLAND DIVISION, CORPS OF ENGINEERS
WALTHAM, MASS. 02154

JULY 1979

SDMS DocID 000213354



015233
GEP





DEPARTMENT OF THE ARMY
NEW ENGLAND DIVISION, CORPS OF ENGINEERS
424 TRAPELO ROAD
WALTHAM, MASSACHUSETTS 02154

REPLY TO
ATTENTION OF

NEDED

NOV 19 1979

Honorable Edward J. King
Governor of the Commonwealth of
Massachusetts
State House
Boston, Massachusetts 02133

Dear Governor King:

Inclosed is a copy of the Woods Pond (Valley Mill) Dam Phase I Inspection Report, which was prepared under the National Program for Inspection of Non-Federal Dams. This report is presented for your use and is based upon a visual inspection, a review of the past performance and a brief hydrological study of the dam. A brief assessment is included at the beginning of the report. I have approved the report and support the findings and recommendations described in Section 7 and ask that you keep me informed of the actions taken to implement them. This follow-up action is a vitally important part of this program.

A copy of this report has been forwarded to the Department of Environmental Quality Engineering, the cooperating agency for the Commonwealth of Massachusetts. In addition, a copy of the report has also been furnished the owner, P. J. Schweitzer Division, Kimberly-Clark Corporation, Lee, Massachusetts 01238.

Copies of this report will be made available to the public, upon request, by this office under the Freedom of Information Act. In the case of this report the release date will be thirty days from the date of this letter.

I wish to take this opportunity to thank you and the Department of Environmental Quality Engineering for your cooperation in carrying out this program.

Sincerely,

MAX B. SCHEIDER
Colonel, Corps of Engineers
Division Engineer

Incl
As stated

HOUSATONIC RIVER BASIN
LEE-LENOX, MASSACHUSETTS

WOODS POND (VALLEY MILL) DAM
MA 00731

PHASE I INVESTIGATION REPORT
NATIONAL DAM INSPECTION PROGRAM

DEPARTMENT OF THE ARMY
NEW ENGLAND DIVISION, CORPS OF ENGINEERS
WALTHAM, MASS. 02154

JULY 1979

PHASE I INVESTIGATION REPORT
NATIONAL DAM INSPECTION PROGRAM

Identification No.: MA 00731
Name of Dam: Woods Pond (Valley Mill)
Town: Lee and Lenox
County: Berkshire
State: Massachusetts
Stream: Housatonic River
Date of Site Visit: 30 May 1979

BRIEF ASSESSMENT

Woods Pond Dam is a rock-filled timber crib spillway structure 165 ft. in length and a maximum of 11.9 ft. in height. Appurtenant to the dam are a head race canal and a gated outlet structure. The dam is over 100 years old, having originally been built to generate power for a paper mill. Presently, water from the head race is used as a fire protection supply for warehouses by the owner of the dam, P.J. Schweitzer Division, Kimberly-Clark Corporation. The dam also serves to impound Woods Pond, an extensive wildlife management area.

Due to the appreciable downstream development that would be affected in the event the dam were to fail, Woods Pond Dam is confirmed as having a "significant" hazard potential in accordance with Corps of Engineers guidelines.

The visual examination of the dam was limited by the heavy flow of water over the spillway. There were no signs of impending structural failure or other conditions which would warrant urgent remedial action, and few specific deficiencies were noted. However, the center section of the spillway is reported to be badly damaged by lateral movement of the rock fill and vertical timber supports. It was reported by the owner and was somewhat visually evident that the spillway has not been repaired in this area. Therefore, the dam can only be considered to be in fair condition at this time.

Based on the "intermediate" size and "significant" hazard potential classifications in accordance with Corps of Engineers guidelines, the test flood for this dam is one-half the Probable Maximum Flood (1/2 PMF). Hydraulic analyses indicate that the test flood outflow of 38,500 cfs (inflow 73,200 cfs or 861 csm) would

overtop the island on the left bank adjacent to the head race (considered to be the top of dam level) by about 22.1 ft. With the water level at the top of dam, the ungated spillway capacity is approximately 3,460 cfs, which is 9 percent of the test flood outflow.

The owner of the dam should engage a registered professional engineer to examine the spillway under no-flow conditions in order to 1) assess the damaged center section and recommend methods of repair and 2) determine its structural stability based on the observed dimensions and condition, as outlined in Section 7.2. Any necessary repairs or modifications resulting from the investigations, and remedial measures including preparation of a formal operations and maintenance manual for the dam and establishment of an emergency preparedness plan, as outlined in Section 7.3, should be implemented by the Owner within 1 year after receipt of this report.

HALEY & ALDRICH, INC.
by:



Harl Aldrich
President

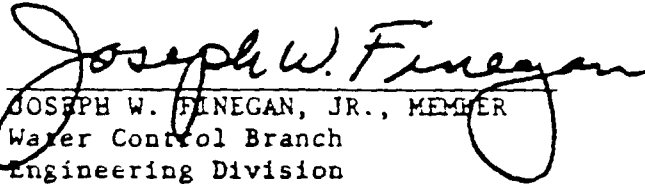

This Phase I Inspection Report on Woods Pond (Valley Mill) Dam has been reviewed by the undersigned Review Board members. In our opinion, the reported findings, conclusions, and recommendations are consistent with the Recommended Guidelines for Safety Inspection of Dams, and with good engineering judgment and practice, and is hereby submitted for approval.

JOSEPH W. FINEGAN, JR., MEMBER
Water Control Branch
Engineering Division

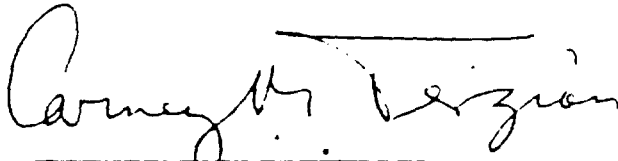
CARNEY M. TERZIAN, MEMBER
Design Branch
Engineering Division

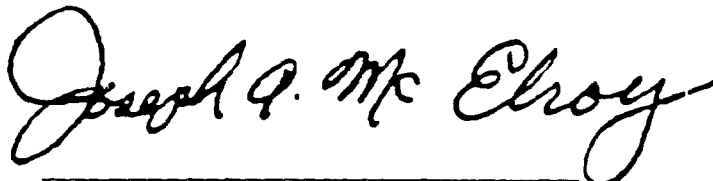
JOSEPH A. MCELROY, CHAIRMAN
Chief, NED Materials Testing Lab.
Foundations & Materials Branch
Engineering Division

APPROVAL RECOMMENDED:

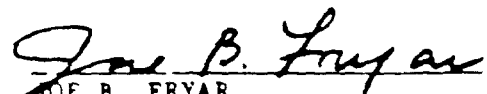
JOE B. FRYAR
Chief, Engineering Division

PREFACE

This report is prepared under guidance contained in the Recommended Guidelines for Safety Inspection of Dams, for Phase I Investigations. Copies of these guidelines may be obtained from the office of Chief of Engineers, Washington, DC 20314. The purpose of a Phase I Investigation is to identify expeditiously those dams which may pose hazards to human life or property. The assessment of the general condition of the dam is based upon available data and visual inspections. Detailed investigation, and analyses involving topographic mapping, subsurface investigations, testing, and detailed computational evaluations are beyond the scope of a Phase I Investigation; however, the investigation is intended to identify any need for such studies.

In reviewing this report, it should be realized that the reported condition of the dam is based on observations of field conditions at the time of inspection along with data available to the inspection team. In cases where the reservoir was lowered or drained prior to inspection, such action, while improving the stability and safety of the dam, removes the normal load on the structure and may obscure certain conditions which might otherwise be detectable if inspected under the normal operating environment of the structure.

It is important to note that the condition of a dam depends on numerous and constantly changing internal and external conditions, and is evolutionary in nature. It would be incorrect to assume that the present condition of the dam will continue to represent the condition of the dam at some point in the future. Only through continued care and inspection can there be any chance that unsafe conditions be detected.

Phase I Investigations are not intended to provide detailed hydrologic and hydraulic analyses. In accordance with the established Guidelines, the test flood is based on the estimated "probable maximum flood" for the region (greatest reasonably possible storm run-off), or a fraction thereof. Because of the magnitude and rarity of such a storm event, a finding that a spillway will not pass the test flood should not be interpreted as necessarily posing a highly inadequate condition. The test flood provides a measure of relative spillway capacity and serves as an aid in determining the need for more detailed hydrologic and hydraulic studies, considering the size of the dam, its general condition and the downstream damage potential. Consideration of downstream flooding other than in the event of a dam failure is beyond the scope of this investigation.

The Phase I Investigation does not include an assessment of the need for fences, gates, no-trespassing signs, repairs to existing fences and railings and other items which may be needed to minimize trespass and provide greater security for the facility and safety to the public. An evaluation of the project for compliance with OSHA rules and regulations is also excluded.

TABLE OF CONTENTS

<u>Section</u>	<u>Page</u>
LETTER OF TRANSMITTAL	
BRIEF ASSESSMENT	
REVIEW BOARD PAGE	
PREFACE	i
TABLE OF CONTENTS	iii
OVERVIEW PHOTO	vi
LOCATION MAP	vii
1. PROJECT INFORMATION	
1.1 General	1
a. Authority	1
b. Purpose of Inspection	1
1.2 Description of Project	2
a. Location	2
b. Description of Dam and Appurtenances	2
c. Size Classification	3
d. Hazard Classification	3
e. Ownership	3
f. Operator	3
g. Purpose of Dam	4
h. Design and Construction History	4
i. Normal Operational Procedures	4
1.3 Pertinent Data	5
2. ENGINEERING DATA	
2.1 Design Data	8
2.2 Construction Data	8
2.3 Operation Data	8
2.4 Evaluation of Data	8

TABLE OF CONTENTS (Continued)

<u>Section</u>	<u>Page</u>
3. VISUAL EXAMINATION	
3.1 Findings	9
a. General	9
b. Dam	9
c. Appurtenant Structures	10
d. Reservoir Area	10
e. Downstream Channel	10
3.2 Evaluation	12
4. OPERATIONAL PROCEDURES	
4.1 Procedures	13
4.2 Maintenance of Dam	13
4.3 Maintenance of Operating Facilities	13
4.4 Description of any Warning System in Effect	13
4.5 Evaluation	13
5. HYDRAULIC/HYDROLOGIC	
5.1 Evaluation of Features	15
a. General	15
b. Design Data	15
c. Experience Data	15
d. Visual Observations	16
e. Test Flood Analysis	17
f. Dam Failure Analysis	17
6. STRUCTURAL STABILITY	
6.1 Evaluation of Structural Stability	20
a. Visual Observations	20
b. Design and Construction Data	20
c. Operating Records	20
d. Post-Construction Changes	20
e. Seismic Stability	20

TABLE OF CONTENTS (Continued)

<u>Section</u>	<u>Page</u>
7. ASSESSMENT, RECOMMENDATIONS AND REMEDIAL MEASURES	
7.1 Dam Assessment	21
a. Condition	21
b. Adequacy of Information	21
c. Urgency	21
d. Need for Additional Investigation	21
7.2 Recommendations	22
7.3 Remedial Measures	22
a. Operation and Maintenance Procedures	22
7.4 Alternatives	23
APPENDIX A - INSPECTION CHECKLIST	A-1
APPENDIX B - ENGINEERING DATA	B-1
APPENDIX C - PHOTOGRAPHS	C-1
APPENDIX D - HYDROLOGIC AND HYDRAULIC COMPUTATIONS	D-1
APPENDIX E - INFORMATION AS CONTAINED IN THE NATIONAL INVENTORY OF DAMS	E-1



1. Overview of Woods Pond (Valley Mill) Dam taken
in April 1979

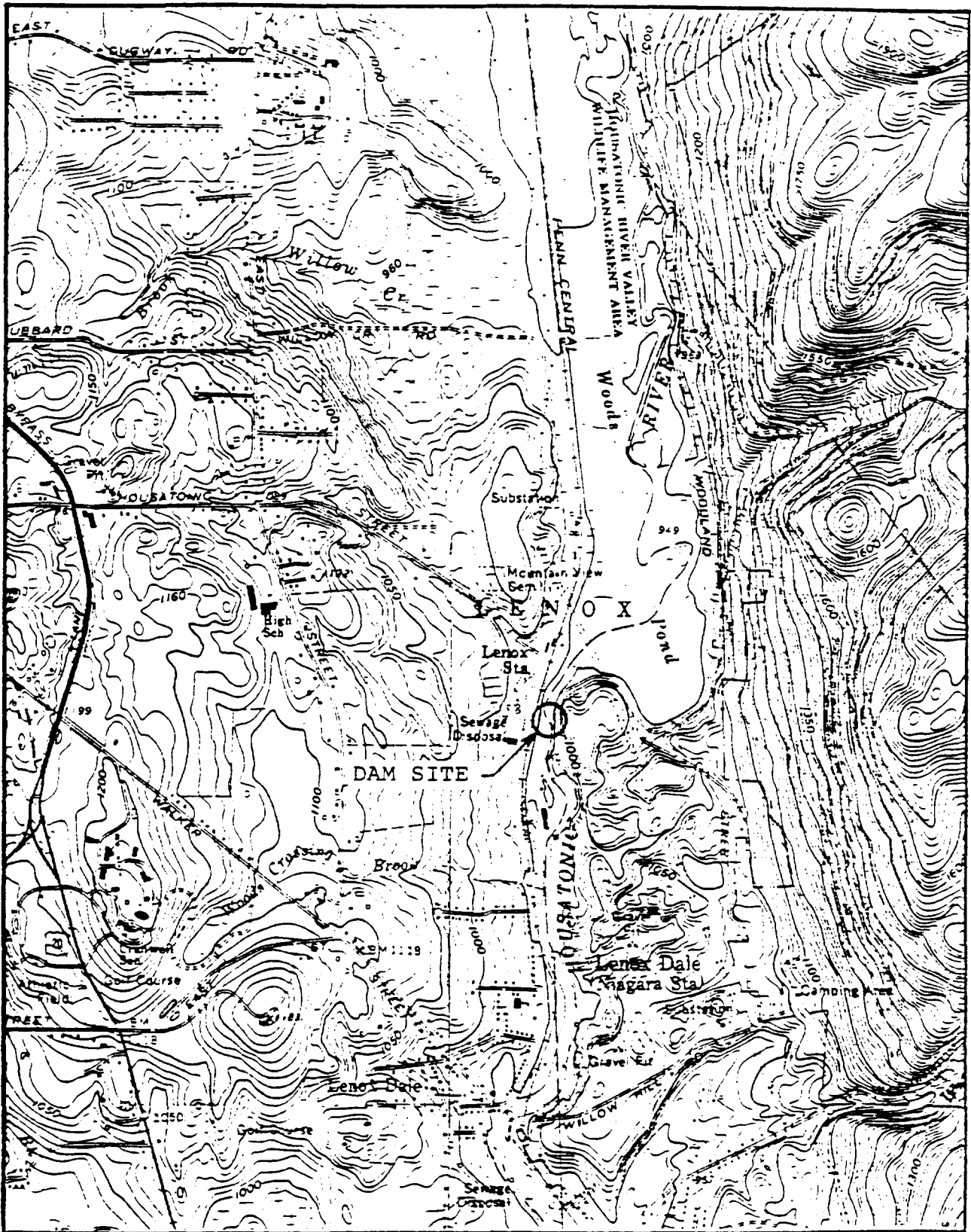

FILE NO. 4270 A27

DAM: WOODS POND (VALLEY MILL)
 IDENTIFICATION NO. MA 00731

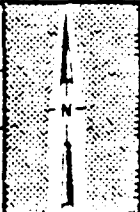

LOCATION MAP
 USGS QUADRANGLE
 EAST LEE, MA
 APPROX. SCALE: 1" = 2000'

PHASE I INVESTIGATION REPORT
NATIONAL DAM INSPECTION PROGRAM
WOODS POND (VALLEY MILL) DAM
MA 00731

SECTION 1 - PROJECT INFORMATION

1.1 General

a. Authority. Public Law 92-367, August 8, 1972, authorized the Secretary of the Army, through the Corps of Engineers, to initiate a National Program of Dam Inspection throughout the United States. The New England Division of the Corps of Engineers has been assigned the responsibility of supervising the inspection of dams within the New England Region.

Haley & Aldrich, Inc. has been retained by the New England Division to inspect and report on selected dams in the State of Massachusetts. Authorization and notice to proceed were issued to Haley & Aldrich, Inc. under a letter dated 28 November 1978 from Colonel Max B. Scheider, Corps of Engineers. Contract No. DACW33-79-C-0018 has been assigned by the Corps of Engineers for this work. Camp, Dresser & McKee, Inc. was retained as consultant to Haley & Aldrich, Inc. on the structural, mechanical/electrical and hydraulic/hydrologic aspects of the Investigation.

b. Purpose of Inspection. The primary purposes of the National Dam Inspection Program are to:

1. Perform technical inspection and evaluation of non-Federal dams to identify conditions which threaten the public safety and thus permit correction in a timely manner by non-Federal interests.

2. Encourage and prepare the states to initiate effective dam safety programs for non-Federal dams.

3. Update, verify and complete the National Inventory of Dams.

1.2 Description of Project

a. Location. Woods Pond (also called Valley Mill) Dam is located across the Housatonic River on the corporate boundary between two towns, Lee and Lenox, in western Massachusetts, as shown on the Location Map, page vii. The latitude and longitude of the dam site are $N42^{\circ}20.9'$ and $W73^{\circ}14.7'$. The Housatonic River flows south from the dam for about 90 miles through Massachusetts and Connecticut before it discharges into Long Island Sound.

b. Description of Dam and Appurtenances. The dam consists of a rock-filled timber crib spillway structure spanning the main branch of the river between stone masonry training walls. A head race canal and gated outlet structure are appurtenant to the dam, as shown on the "Site Plan Sketch", page C-1.

The dam is "V"-shaped in plan with an overall length of 165 ft. The height of the spillway structure itself is 9.6 ft. However, the top of dam or level at which the island on the left bank would begin to overtop is 2.3 ft. above the spillway cap, giving the dam a maximum height of 11.9 ft. There is reportedly rock protection on the upstream slope and timber planking on the downstream face of the spillway, as shown in cross-section on a sketch from a prior inspection report, page B-7. The dam is shown on Photos No. 1, 2 and 4.

A portion of the river flow is diverted to a head race canal left of the dam, Photos No. 4, 5 and 6. There is a gated regulatory outlet to return water from the canal back to the Housatonic River located at a gate house about 500 ft. downstream of the head race entrance. The invert of the two slide gates is estimated to be 7 ft. lower than the spillway crest. This outlet is shown on Photos No. 7, 8 and 9.

The head race canal continues downstream past the gate house to a mill pond, where the impounded water was once used to generate power. The dam, head race and mill pond were all part of a paper mill complex shown in plan on page B-11. The mill pond level is now controlled by a makeshift rubble spillway, Photo No. 10, which discharges to the Housatonic River about 1,800 ft. downstream of the dam.

c. Size Classification. The storage to the top of Woods Pond Dam is estimated to be 2,000 acre-ft., and the maximum height of the dam is approximately 11.9 ft. Because the maximum storage capacity of the dam is between 1,000 and 50,000 acre-ft., the dam is classified in the "intermediate" size category according to the guidelines established by the Corps of Engineers.

d. Hazard Classification. The preliminary computations for dam failure analysis presented in Appendix D and based on the Corps of Engineers' "Guidance for Estimating Downstream Dam Failure Hydrograph" confirm that this dam has a "significant" hazard potential. Failure of the rock-filled timber crib dam would result in a potential for loss of a few lives, primarily employees at downstream commercial activities and those who dwell near the river in Lenox Dale. In addition, appreciable damage to homes and commercial and industrial buildings is probable.

e. Ownership. The name, address and phone number of the current owner are:

P.J. Schweitzer Division,
Kimberly-Clark Corporation
Lee, Massachusetts 01238
Phone: 413-243-1100

Mr. Wayne Galey, Electrical Engineering Superintendent, acted as the owner's representative during the course of this investigation.

The former mill complex which includes the dam and appurtenances was built by Thomas Sedgewick & Co. and originally known as Valley Mill, according to historical records in the Town of Lee library. In 1864, Smith Paper Inc. acquired the Valley Mill property and operated the mill until after World War I. Brown and Williamson, a tobacco company, became the owner sometime after September 1942, using the property for warehousing purposes. Likewise, P.J. Schweitzer Co. has operated warehouses on the property since 1949. In 1955, P.J. Schweitzer Co. became a division of Kimberly-Clark Corporation.

f. Operator. Mr. J.J. Burns heads the plant

protection department of P.J. Schweitzer Division and is thus currently responsible for the operation, maintenance and safety of the dam. An employee from his department, Mr. George Allen, visits the dam site daily. Mr. Allen has been familiar with the mill complex as an employee since 1942.

g. Purpose of Dam. The dam was originally built to regulate the level of water in the appurtenant head race and mill pond in order to generate power at the mill complex downstream of the dam. The dam served this purpose from the 1800's up until around 1920. Since that time the only purpose of the dam to the owners has been to maintain an adequate fire protection supply in the mill pond for the nearby warehouses.

It should also be noted that the dam serves to impound extensive Woods Pond area upstream of the dam. This area is designated as the Housatonic River Valley Wildlife Management Area and thus has recreational value. Since the economic usefulness of the dam to the current owner is quite limited and eventually will be nonexistent, attempts are being made by the owner to transfer ownership of the dam to an appropriate state agency.

h. Design and Construction History. Height of dam certificates were issued to Woods Pond (then called Valley Mill) Dam in 1872 and 1898, according to information contained on a plan of the Valley Mill property dated September 1942, included as page B-11. The dam is therefore over 100 years old. No further information regarding its original design and construction was disclosed.

Post-construction modifications to the dam such as the concrete cap on the spillway crest are apparent. The only specific repairs to the dam disclosed were the partial displacement of uplifted and broken timber planks on the downstream face of the dam in September 1976.

i. Normal Operational Procedures. There is no formally established routine for the operation of this dam. The owner's representative inspects the dam and gate house further downstream at the head race outlet once a day in the morning and will regulate the

flow over the spillway by operating the gates as he feels is required.

1.3 Pertinent Data

All elevation reported herein are approximate and based on the assumption that the top of the spillway weir cap is at El. 949.0 National Geodetic Vertical Datum (NGVD), the level of Woods Pond shown on the 1973 USGS East Lee Quadrangle Map.

a. Drainage Area. Woods Pond Dam is located on the Housatonic River. The drainage area is approximately 170 square miles of mostly rolling and mountainous terrain. Throughout the drainage area are several lakes, ponds and reservoirs, the largest of which is Pontoosuc Lake with an area of just over 500 acres. In all, these water bodies comprise approximately 2.5 percent of the total area. A map of the drainage area is shown on page D-1.

Woods Pond Dam is only one of several dams on the Housatonic River. Upstream from Woods Pond Dam, however, the closest dams are several miles away and relatively low in height.

b. Discharge at Dam Site.

1. Outlet works..... Gated outlet structure on head race with invert of El. 942.0
2. Maximum known flood at dam site..... Unknown
3. Ungated spillway capacity at top of dam..... 3,460 cfs at El. 952.3
4. Ungated spillway capacity at test flood pool elevation... 28,000 cfs at El. 974.4
5. Gated spillway capacity at normal pool elevation..... Not applicable
6. Gated spillway capacity at test flood pool elevation... Not applicable
7. Total spillway capacity at test flood pool elevation... 28,000 cfs at El. 974.4
8. Total project discharge at test flood pool elevation... 38,500 cfs at El. 974.4

c. Elevation (ft. above NGVD)

1. Streambed at centerline of dam..... 940.4
2. Maximum tailwater..... Unknown
3. Upstream portal invert diversion tunnel..... Not applicable
4. Recreation pool..... 949.0
5. Full flood control pool..... Not applicable
6. Spillway crest..... 949.0
7. Design surcharge - original design..... Unknown
8. Top of dam..... 952.3
9. Test flood design surcharge. 974.1

d. Reservoir

1. Length of maximum pool..... 6.0 mi. (Est.)
2. Length of recreation pool... 0.7 mi. (Est.)
3. Length of flood control pool..... Not applicable

e. Storage (acre-feet)

1. Recreation pool..... 550
2. Flood control pool..... Not applicable
3. Spillway crest..... 550
4. Top of dam..... 2,200
5. Test flood pool..... 40,000

f. Reservoir Surface (acres)

1. Recreation pool..... 270
2. Flood control pool..... Not applicable
3. Spillway crest..... 270
4. Top of dam..... 650
5. Test flood pool..... 2,650

g. Dam

1. Type..... Rock-filled timber crib structure
2. Length..... 165 ft.
3. Height..... 11.9 ft. maximum
4. Top width..... Concrete weir cap
2 ft. wide

- 5. Side slopes..... Could not be determined (See sketch, page B-7)
- 6. Zoning..... Unknown
- 7. Impervious core..... Unknown
- 8. Cutoff..... Unknown
- 9. Grout curtain..... Unknown

h. Diversion and Regulating Tunnel. Not applicable

i. Spillway

- 1. Type..... Gravity overflow with timber-faced apron and concrete cap
- 2. Length of weir..... 165 ft.
- 3. Crest elevation..... 949.0
- 4. Gates..... None at dam site
- 5. U/S channel..... Defined by steep slopes overgrown with vegetation. Stones and boulders observed at water's edge
- 6. D/S channel..... Defined by steep slopes overgrown with vegetation. Flows in relatively straight path to Lenox Dale

j. Regulating Outlets. There are two (2) single-stemmed manually-operated (through rack and pinion gears) gates in an outlet structure located downstream in the head race. The gates are 5.5 ft. wide by 4.0 ft. high with an estimated invert of El. 942.0.

SECTION 2 - ENGINEERING DATA

2.1 Design Data

No design data for the original dam are available.

2.2 Construction Data

No engineering data regarding the original construction of the dam are available. Certain details of recent construction repairs to the spillway structure and outlet works are given in the 1974 and 1976 state inspection reports.

2.3 Operation Data

No operational records for this dam other than two state inspection reports were disclosed for this dam.

2.4 Evaluation of Data

a. Availability. A list of the limited quantity of engineering data available for use in preparing this report is included on page B-1. Copies of the documents from the listing are also included in Appendix B.

b. Adequacy. There was a lack of engineering data available to aid in the evaluation of Woods Pond Dam. This Phase I assessment was therefore based primarily on visual examination, approximate hydraulic and hydrologic computations, consideration of past performance and application of engineering judgement.

c. Validity. The information contained in the engineering data may generally be considered valid.

SECTION 3 - VISUAL EXAMINATION

3.1 Findings

a. General. The Phase I visual examination of Woods Pond (Valley Mill) Dam was conducted on 30 May 1979. The upstream water surface elevation was relatively high on that day, about 1.2 ft. above the spillway crest.

In general, the dam can only be considered to be in fair condition. Few specific deficiencies which require correction were noted, but the spillway was obscured by a heavy flow of water and it is evident that the reported damage to the center section of the spillway due to internal movement has not yet been repaired.

A visual inspection check list is included in Appendix A and selected photographs of the project are given in Appendix C. A "Site Plan Sketch", page C-1, shows the direction of view for each photograph.

b. Dam. The main dam (spillway) is a run-of-river type extending across the main branch of the Housatonic River, Photos No. 1, 2 and 4. The downstream face of the spillway is sloped. Although there was a heavy flow of water over the spillway making a complete visual inspection impossible, it was determined that the crest of the dam is of concrete and the sloping downstream face is of wood planks. Some turbulence on the downstream face is apparent near the center of the structure, Photos No. 2 and 4. This turbulence may be resulting from the reported upward movement of wood planks which was caused by lateral movement of rock fill and vertical supports within the dam (see prior inspection reports, Appendix B).

The grouted stone masonry abutment walls on each side of the spillway are in good condition with some rusting and staining observed, Photos No. 2 and 4. Immediately behind the right abutment wall there is a short earth embankment about 0.5 ft. lower than the masonry wall. However, the embankment is about

2.3 ft. higher than the lowest portions of the island on the left which is considered to be the top of dam level.

c. Appurtenant Structures. Beyond the left abutment wall of the spillway, there is a concrete wall in good condition protecting the north end of the island between the spillway and the stone masonry wall on the right side of the head race, Photo No. 5. The entrance to the head race is formed in general by two grouted stone masonry walls which are in good condition. There are slots in the stone masonry walls which are surfaced with a concrete coating which would indicate that some type of a control structure may have been at this location; Photo No. 6.

About 500 ft. downstream from the head race entrance is an outlet structure which allows water from the head race to return to the Housatonic River. The access bridge and the superstructure which houses the mechanism for two gates are in excellent condition, Photo No. 7. The concrete superstructure is in good condition with some minor rusting, staining, efflorescence, and surface erosion observed, Photo No. 8. Both training walls show minor cracks and the left wall appears to have three tie backs, Photo No. 9. The two wooden gates have single stems and are in good condition. Both gates were partially open during the site visit, Photo No. 8. Although the gates were not operated during the site visit, it is understood that they are operated periodically.

d. Reservoir Area. Woods Pond upstream of the dam is part of the Housatonic River Valley Wildlife Management Area. The shoreline is wooded and relatively undeveloped. Penn Central railroad tracks run along the west bank, Photo No. 3, and an unpaved road at the base of the Washington Mountain State Forest area runs along the east bank. There is no significant probability of landslides into the reservoir affecting the safety of the dam. Sedimentation on the upstream side of the dam is likely, but its extent could not be determined.

e. Downstream Channel. The dam serves as a diversion structure on the Housatonic River, allowing a small part of the upstream flow to pass through a head race canal to a mill site approximately 0.3 miles

downstream where the diverted flow was once used as a power source.

The head race flows back into the Housatonic River at two locations. Less than 0.1 mile downstream from Woods Pond Dam is an outlet and control structure for redirecting flow in the head race back to the Housatonic River. Farther downstream at the mill site, the head race channel widens into a pond known as Mill Pond. The outlet from this pond is loose rubble that forms a spillway, Photo No. 10, from which flow enters the downstream part of the head race and then back to the Housatonic. The inlet structure shown on page B-11 leading to the old mill buildings has been filled in.

The downstream channel is approximately 170 ft. wide at the toe of the dam, but narrows to approximately 100 ft. wide 300 ft. downstream from the dam. The channel bottom is composed of stones and boulders. The banks are quite clearly defined, rising abruptly from the water surface. Channel depth generally ranges from 10 to 15 ft.

The overall length of the Housatonic River evaluated in this study extends from Woods Pond Dam to the Lenox Dale Bridge, approximately 1.0 mile downstream. The river channel ranges from approximately 50 to 150 ft. wide throughout this length. River water depth on the day of the site visit was approximately 3 to 5 ft. The channel bottom is characterized by cobbles and boulders. The banks are covered by trees and bushes. The slope of the stream bottom is approximately 0.0025.

Three bridges pose the largest obstructions to high flow conditions within the downstream length evaluated. The largest obstruction is at the Lenox Dale Bridge. Although it is a single-span structure, its narrow approach channel has a considerable back-water effect. Approximately 250 ft. upstream from the Lenox Dale Bridge is a wooden railroad tressle. The channel is wide at this tressle, but the many wooden piles supporting the tressle reduce the effective flow area.

Parallel to the Housatonic River and Woods Pond are a two lane paved highway and the Penn Central

Railroad on the west bank and an unpaved road on the east bank. Access to the unpaved road from the paved highway is provided by a single span bridge over the Housatonic approximately 0.26 miles downstream from Woods Pond Dam, at the mill site. Its deck is composed of open steel grating.

Another bridge was taken into consideration for this study, but it does not cross the Housatonic. This bridge, part of the previously-mentioned unpaved road, crosses the head race at the site of the outlet structure.

Development along the part of the Housatonic River evaluated is extensive only in Lenox Dale. Some single family houses and some businesses and offices are located primarily on the west bank of the Housatonic in Lenox Dale.

The mill site contains some of the original mill buildings along the east bank. These buildings are used for storage by the P.J. Schweitzer Division, Kimberly-Clark Corporation. Opposite the old mill buildings on the west side of the Housatonic are some warehouses also owned by P.J. Schweitzer.

Closer to the dam, two single-family homes are located upstream from the mill site. They are located between the mill site and the outlet control structure, on the highest ground between the head race and the Housatonic River.

3.2 Evaluation

There was a heavy flow of water over the spillway obscuring the components from view, thus making a meaningful observation impossible. The evenness of the flow over the weir, however, would tend to indicate that no major lateral or vertical movement has taken place. Turbulence observed near the center on the downstream face is believed to indicate the location where spillway damage was noted in prior inspection reports made at times when the upstream reservoir was drawn down. The condition of Woods Pond (Valley Mill) Dam can therefore only be considered fair because the extent of the reported spillway damage could not be assessed at this time.

SECTION 4 - OPERATIONAL PROCEDURES

4.1 Procedures

In general, there are informal procedures to provide routine maintenance and satisfactory operation of the dam. An employee of the owner visits the dam site on a daily basis and makes a visual examination. Woods Pond is lowered each year, usually in August, in order to closely examine the dam and make necessary repairs.

4.2 Maintenance of Dam

There is no formal maintenance program for this dam. The owner's representative indicated the pond is lowered once a year and the dam is inspected and repaired as required. The timber plank apron of the dam was partially repaired in September 1976. The reportedly badly damaged center portion is scheduled to be repaired during the last two weeks of August 1979.

4.3 Maintenance of Operating Facilities

The gate house and gates downstream from the dam appear to be well maintained. The superstructure and gates were rebuilt in 1976. Normal maintenance of this facility is on a demand basis.

4.4 Description of any Warning System in Effect

There is no warning system or emergency preparedness plan in effect for this structure.

4.5 Evaluation

The owner should prepare an operations and maintenance manual for the dam. The manual should delineate the routine operational procedures and maintenance work to be done on the dam to provide satisfactory operation and minimize deterioration of the facility. It should also include specific items to be checked during the annual examination of the dam. A formal maintenance program should be established to systematically maintain the spillway, outlet structure, walls and channels. A formal procedure should be established to operate the reservoir drain periodically and monitor the dam during

periods of heavy precipitation and high project discharges.

Since failure of the dam would probably cause loss of life and significant property damage downstream, the owner should also prepare and implement a formal emergency preparedness plan and warning system.

SECTION 5 - HYDRAULIC/HYDROLOGIC

5.1 Evaluation of Features

a. General. Woods Pond Dam is a rock-filled timber crib dam with a concrete weir cap and timber spillway facing on the downstream side. It is located on the Housatonic River and diverts part of the Housatonic's flow through a head race canal to a pond at the downstream mill site. The head race flows back into the Housatonic River at a point near the mill site and also through an outlet structure near Woods Pond Dam.

Downstream bridges pose the major obstructions to high flow conditions. The flow obstructions result in the relatively high tailwater at the dam at high flow.

The terrain upstream from the dam is flat in the vicinity of the river. As a result of this and the tailwater effect at high flows, there is a large amount of channel storage under test flood flow conditions.

b. Design Data. No hydrologic or hydraulic design data were available for this dam site.

c. Experience Data. Geologic Water-Supply Paper 1671, Magnitude and Frequency of Floods in the United States, presents gage height data on the Housatonic at a point several miles downstream from Woods Pond Dam in Great Barrington, Massachusetts.

These data, representing peak stages and discharges for the years 1914 through 1960, show annual high water elevations that range from 5.0 to 12.08 ft. The highest recorded stage occurred on 1 January 1949. Peak annual discharges have ranged between 1,400 and 12,200 cubic feet per second, the latter also occurring 1 January 1949. Although these data are useful in a general sense, gage heights are somewhat biased through the upstream regulation of flow by power plants above the station.

One of the most disastrous floods in the Housatonic basin took place in September 1938. A document prepared by the Massachusetts Geodetic Survey in 1939, entitled High Water Data - Floods of March 1936 and September 1938, presents the Housatonic River profile and noteworthy

high water elevations at points along the river. At the bridge near the mill downstream from Woods Pond Dam the water surface reached El. 954.3, submerging the roadway by 0.1 ft.

During the site visit, Mr. Wayne Galey, Electrical Engineering Superintendent of P.J. Schweitzer Division, Kimberly-Clark Corporation, gave a brief history of the highest flooding in recent years. In Spring 1974, water overtopped the bank behind the mill buildings as well as the banks of the head race canal. The damage amounted to scouring of the land upstream of the northernmost of the two houses situated between the head race and the Housatonic River. Despite this flooding, no damage was done to the houses, and the area scoured was repaired by P.J. Schweitzer Division.

d. Visual Observations. The site visit at Woods Pond Dam was made on 30 May 1979. The local weather preceding this day was characterized by a prolonged rainy period. Consequently, the height of flow over the spillway during the site visit was approximately 1.2 ft. The water depth at the toe of the dam was greater than three feet. A relatively small portion of the flow was passing through the head race canal. Some of this flow returned to the Housatonic through the outlet control structure and the remainder returned at the mill site.

Side banks of the Housatonic were overgrown with vegetation ranging from saplings and bushes to mature trees. The channel bottom was composed of boulders and stones. Some large boulders had been deposited on the banks.

The two homes between the outlet control structure and the mill site appeared to be occupied. There was little activity at the mill site, where the old mill buildings are now used mostly for long term storage. Across the river, however, there was considerable activity at the warehouses.

Downstream, in Lenox Dale, there was activity at an oil depot on the west bank and at a sand and gravel operation on the east bank. Houses were all apparently occupied. Businesses in the center of Lenox Dale were open.

e. Test Flood Analysis. The Corps of Engineers guidelines recommend using flow equalling between one-half the Probable Maximum Flood (1/2 PMF) and the full PMF for "intermediate" size, "significant" hazard potential dams such as Woods Pond Dam. For this study, 1/2 PMF was used as the test flood. The PMF was determined using the Corps of Engineers "Guidelines for Estimating Maximum Probable Discharge in Phase I Dam Safety Investigations". The terrain of the watershed is mostly rolling and mountainous with some low-lying flatlands. An inflow rate of 861 cfs per square mile (csm) was selected for the total watershed of 170 square miles, resulting in a PMF of 146,400 cfs or 1/2 PMF of 73,200 cfs.

The test flood outflow, as shown in Appendix D, was calculated to be approximately 38,500 cfs. This outflow results in a test flood water surface elevation of approximately 22.1 ft. above the top of the dam and submergence of the spillway by an estimated 12.1 ft. in relation to the tailwater. The capacity of the spillway is approximately 3,460 cfs or nine (9) percent of the estimated test flood outflow.

The difference between the test flood inflow and outflow is much larger than would be expected on a run-of-river type dam. There are several reasons for this difference. First, the highest recorded flow since 1914 at the downstream U.S.G.S. gaging station is 12,200 cfs (in 1949), whereas the test flood inflow used in this study is 73,200 cfs (1/2 PMF). The spillway crest elevation is approximately 949.0 feet NGVD and it is submerged at flows above approximately 3,500 cfs. As a result, the downstream tailwater affects the upstream water surface elevations at the test flood inflow and outflow. Another factor is that the topography of the upstream river valley is relatively flat, allowing for a larger storage capacity at excessively high flows. This characteristic is reflected on the area-volume curves in Appendix D. On these curves, it can be seen that at elevations above approximately 950 NGVD (approximately one foot above spillway crest height) the area and volume increase greatly as elevation increases.

f. Dam Failure Analysis. The peak failure outflow has been calculated using the Corps of Engineers' "Guidelines for Estimating Dam Failure Hydrographs". Computations for dam failure analysis are presented in Appendix D of this report.

It was assumed that the breach of Woods Pond Dam is 90 percent of its total length at its mid-point and that the dam failure occurs when the water surface elevation is at the top of the dam. Using these assumptions, the outflow due to dam failure was calculated to be approximately 9,940 cfs. The flow just prior to failure would be approximately 3,460 cfs. Nowhere in the reaches investigated does this 3,460 cfs yield stages above the river channel banks. This means that those who are potentially endangered by a dam failure would have little forewarning.

Preliminary flood routing analyses showed that the flood wave would pass over the channel banks throughout much of the downstream area evaluated. However, in Lenox Dale the wave is expected to be confined to within the normal channel. Three reaches were examined between the dam and Lenox Dale.

Reach 1 extends 2,600 ft. downstream of the dam. The flow at the downstream end of Reach 1 would be approximately 9,000 cfs. Within this reach, the relatively steep sloping channels would probably minimize most of the adverse effects of a failure. However, the two residences between the head race and the Housatonic River would be flooded by an estimated 2 to 4 ft. of water, resulting in a potential loss of life. The bridge adjacent to the mill buildings would be under an estimated 5 ft. of water, as would the area around the mill buildings on both banks of the river. Because these buildings are currently used for storage and warehousing, damage would be expected to stored articles, and the potential for loss of lives of employees working around these buildings would be high.

Reach 2 extends to the railroad bridge crossing in Lenox Dale. The downstream flow for this reach would be approximately 7,940 cfs. The sand and gravel operation on the east bank would be under an estimated 2 to 4 ft. of water. On the west bank, flood waters would be approximately 2 to 4 ft., varying with the distance from the river channel. A workshop, a house, and a garage could be flooded by a failure flood.

Reach 3 is approximately 250 ft. long, between the railroad tressle and the Lenox Dale Bridge. Characteristically flat terrain and a steeper channel bottom slope result in reducing the water surface elevation to well within the normal channel area.

Because the developments most vulnerable to flooding are not extensive nor highly populated, a dam failure could result in loss of a few lives and appreciable damage to property. Therefore, the hazard potential classification is considered to be significant, in accordance with the Corps of Engineers' Guidelines.

SECTION 6 - STRUCTURAL STABILITY

6.1 Evaluation of Structural Stability

a. Visual Observations. Although the spillway was obscured from view by a heavy flow of water, no visual evidence of instability as a whole was noted during the site visit on 30 May 1979. Turbulence noted on the downstream side near the center indicates that some local damage to the structure has occurred. This condition has never been repaired since it was originally observed in 1974.

b. Design and Construction Data. There are no known design and construction data on the dam, thus precluding a theoretical analysis of structural stability. The assessment of the dam for structural stability is therefore based on visual observations.

The owner's representative indicated that the dam is a rock-filled wooden crib dam with a sloped wooden plank apron. The crest of the dam is a concrete cap. It was reported and indicated in the 1976 state inspection report that the dam was partially repaired in September 1976. It was also reported that gates and gate house superstructure were rebuilt in the spring of 1976. Repairs are still needed near the badly damaged center section of the spillway apron according to prior inspection reports in Appendix B.

c. Operating Records. No operating records are known to exist for the spillway and regulating outlet to aid in the evaluation of structural stability.

d. Post-Construction Changes. No post-construction changes are known for this dam (spillway). Since the dam is considered to be over 100 years old, the presence of the concrete spillway weir cap, the concrete walls at the entrance of the head race and the concrete outlet structure indicate that some past construction changes have been made.

e. Seismic Stability. The dam is located in Seismic Zone 1 and in accordance with recommended Phase I Guidelines does not warrant seismic analysis.

SECTION 7 - ASSESSMENT, RECOMMENDATIONS
AND REMEDIAL MEASURES

7.1 Dam Assessment

a. Condition. The visual examination of Woods Pond (Valley Mill) Dam was limited by the heavy flow of water over the spillway. There were no signs of impending structural failure or other conditions which would warrant urgent remedial action and few specific deficiencies were noted. However, due to turbulence observed in the area where reported damage to the spillway has not yet been repaired, the dam can only be considered to be in fair condition.

Based on the results of computations included in Appendix D and described in Section 5, the spillway is not capable of passing the test flood, which for this structure is the 1/2 PMF. The test flood outflow of 40,000 cfs (inflow 73,200 cfs or 861 csm) would overtop the dam by about 21.8 ft. With the water level at the top of dam, the spillway capacity is about 3,460 cfs, which is 9 percent of the test flood outflow.

b. Adequacy of Information. This evaluation of the dam is based primarily on visual examination, preliminary hydraulic and hydrologic computations, consideration of past performance and application of engineering judgement. Generally the information available or obtained was adequate for the purposes of a Phase I assessment. However, it is recommended that additional information regarding the condition and dimensions of the spillway be obtained as outlined in Section 7.2.

c. Urgency. The recommendations for additional investigations and remedial measures outlined in Section 7.2 and 7.3, respectively, should be undertaken by the Owner and completed within one year after receipt of this report.

d. Need for Additional Investigation. Additional investigations should be performed by the Owner as outlined in Section 7.2.

7.2 Recommendations

It is recommended that the Owner engage a registered professional engineer to undertake the following investigations:

1. Perform an inspection of the spillway during no-flow conditions. In particular, assess the reported movement of the vertical timbers and rock fill near the center of the spillway and recommend methods for repairing the damaged area.
2. Determine accurately the dimensions of the dam (spillway) in order to evaluate its structural stability under static loads.

The Owner should then implement corrective measures on the basis of this engineering evaluation.

7.3 Remedial Measures

Since the spillway structure was obscured by heavy flow, few specific deficiencies were noted. It is considered important that the following items be accomplished.

a. Operation and Maintenance Procedures. The following remedial measures should be undertaken by the Owner:

1. Prepare a formal operation and maintenance manual for the dam. The manual should include the specific items to be checked during the annual technical inspection of the dam and provisions for round-the-clock surveillance of the dam during periods of heavy precipitation and high project discharges. The procedures in the manual should delineate the routine operational procedures and maintenance work to be done on the dam to ensure safe, satisfactory operation and to minimize deterioration of the facility.
2. Develop a written emergency preparedness plan and warning system to be used in the event of

impending failure of the dam or other emergency conditions. The plan should be developed in cooperation with local officials and downstream inhabitants.

7.4 Alternatives

Not applicable.

APPENDIX A - INSPECTION CHECK LIST

	<u>Page</u>
<u>VISUAL INSPECTION PARTY ORGANIZATION</u>	A-1
<u>VISUAL INSPECTION CHECK LIST</u>	
Outlet Works - Spillway Weir, Abutment Walls, Approach and Discharge Channels	A-2
Outlet Works - Head Race	A-3
Outlet Works - Outlet Structure	A-3

VISUAL INSPECTION PARTY ORGANIZATION

NATIONAL DAM INSPECTION PROGRAM

Dam: Woods Pond (Valley Mill) Dam

Date: 30 May 1979

Time: 0700-1000

Weather: Low overcast with light fog, temperature 60's F

Water Surface Elevation Upstream: El. 950.2 (1.2 ft. above
top of concrete
spillway weir
cap)

Stream Flow: Estimated 1,000 cfs

Inspection Party:

Harl P. Aldrich, Jr.	- Soils/Geology
Richard A. Brown	
Haley & Aldrich, Inc.	
A. Ulvi Gulbey	- Hydraulic/Hydrologic
Robert H. Sheldon	
Robert P. Howard	- Structural/Mechanical
Camp, Dresser & McKee, Inc.	

Present During Inspection:

Mr. Wayne Galey, Electrical Engineering Superintendent
Mr. George Allen, Plant Protection Department
P.J. Schweitzer Division, Kimberly-Clark Corporation

**VISUAL INSPECTION CHECK LIST
NATIONAL DAM INSPECTION PROGRAM**

DAM: Woods Pond (Valley Mill) DATE: 30 May 79

AREA EVALUATED	CONDITION
<p><u>OUTLET WORKS - SPILLWAY</u> <u>WEIR, ABUTMENT WALLS,</u> <u>APPROACH AND DISCHARGE</u> <u>CHANNELS</u></p>	
<p>a. <u>Approach Channel</u></p>	
General Condition	Satisfactory. Dam (spillway) extends across main branch of Housatonic River
Loose Rock Overhanging Channel	None observed
Trees Overhanging Channel	Yes, both banks
Floor of Channel	Submerged
<p>b. <u>Weir and Abutment Walls</u></p>	
General Condition of Weir	Free - flow weir submerged by heavy flow of water. Crest of weir is concrete. Downstream sloped face is wooden planks. Close inspection of spillway not possible due to heavy flow of water. Turbulence noted near center of downstream face, possibly due to uplifted planks
General Condition of Abutment Walls	Grouted stone masonry in good condition
Vegetation	None observed
Any Seepage or Efflorescence	None observed
Rust or Stains	Minor rusting and stains observed
Cracks	None observed
Drain Holes	None observed
Condition of Joints	Good
<p>c. <u>Discharge Channel</u></p>	
General Condition	Satisfactory. Discharge over spillway is directly to the Housatonic River
Loose Rock Overhanging Channel	None observed

FILE NO. 4160

**VISUAL INSPECTION CHECK LIST
NATIONAL DAM INSPECTION PROGRAM**

DAM: Woods Pond (Valley Mill) DATE: 30 May 79

AREA EVALUATED	CONDITION
<p>Trees Overhanging Channel Floor of Channel Other Obstructions</p>	<p>Yes, on both banks Submerged by 3 to 5 ft. None observed</p>
<u>OUTLET WORKS - HEAD RACE</u>	
<p>General Condition of Head Race</p>	<p>General condition of head race is good. Walls are in general grouted stone masonry in good condition. A concrete wall extends from spillway to the stone masonry wall on right side of head race. Slots in the concrete covered stone masonry walls in poor condition</p>
<p>Rust or Staining</p>	<p>Minor rust and staining in concrete wall</p>
<p>Spalling</p>	<p>Spalling of concrete observed at slotted wall</p>
<p>Visible Reinforcing</p>	<p>None observed</p>
<p>Any Seepage or Efflorescence</p>	<p>None observed</p>
<p>Condition at Joints</p>	<p>Good</p>
<p>Drain Holes</p>	<p>None observed</p>
<p>Loose Rock or Trees Overhanging Head Race</p>	<p>Some trees overhanging head race</p>
<u>OUTLET WORKS - OUTLET STRUCTURE</u>	
a. <u>Concrete and Structural</u>	
<p>General Condition</p>	<p>Generally in good to excellent condition. The wooden superstructure and service bridge are in excellent condition while the concrete superstructure is in good condition</p>
<p>Condition of Joints</p>	<p>Good</p>
<p>Spalling</p>	<p>None observed</p>
<p>Visible Reinforcing</p>	<p>None observed</p>

FILE NO. 4160

**VISUAL INSPECTION CHECK LIST
NATIONAL DAM INSPECTION PROGRAM**

DAM: Woods Pond (Valley Mill) DATE: 30 May 79

AREA EVALUATED	CONDITION
Rusting or Staining of Concrete Any Seepage of Efflorescence Joint Alignment Unusual Seepage or Leaks in Gate Chamber Cracks Rusting or Corrosion of Steel Other	Minor rusting and staining of concrete substructure observed Minor seepage and efflorescence observed in substructure Good None observed Minor cracks in both wing walls of substructure None observed Three tie-backs in left wing wall. Bolts and plates in good condition
b. <u>Mechanical and Electrical</u>	
Service Gates Lightning Protection System Emergency Power System Wiring and Lighting System in Gate House	Two (2) single-stemmed manually operated (through rack and pinion gears) gates in excellent condition Gates not operated during inspection None observed None observed None observed
c. <u>Service Bridge</u>	
General Condition Deck Bridge Beams Railings Paint	Excellent Wooden plank deck in excellent condition Steel wide flange members in excellent condition Good condition Good condition

FHE NO. 4160

APPENDIX B - ENGINEERING DATA

	<u>Page</u>	
<u>LIST OF AVAILABLE DATA</u>	B-1	
<u>PRIOR INSPECTION REPORTS</u>		
<u>Date</u>	<u>Description</u>	
14 August 1974	Mass. Dept. of Public Works	B-2
21 September 1976	Mass. Dept. of Public Works	B-8
<u>DRAWINGS</u>		
Plan of Land owned by Smith Paper, Inc. dated September 1942		B-11

LIST OF AVAILABLE DATA
WOODS POND (VALLEY MILL) DAM

<u>Document</u>	<u>Contents</u>	<u>Location</u>
Plan of land in Lee and Lenox owned by Smith Paper, Inc., known as the Valley Mill Property, E.G. Pease, Engineer, Lee, MA, September 1942	Scale: 1" = 50' Abstract Plan	P.J. Schweitzer Division, Kimberly-Clark Corporation, Lee, MA 01238 and page B-11
State inspection reports, Dam No. 1-2-150-11	Two reports on file. One dated 14 August 1974 in- cludes description of dam. Other dated 21 September 1976	Mass. Dept. of Environmental Quality Engineering, Division of Waterways, 100 Nashua Street, Boston, MA 02114 and page B-2

INSPECTION REPORT - DAMS AND RESERVOIRS

1. Location: City/Town LEE Dam No. 1-2-150-11
Name of Dam VALLEY MILL Inspected by: RD Jordan
Date of Inspection 8/14/74

2. Owner/s: per: Assessors _____ Prev. Inspection _____
Reg. of Deeds _____ Pers. Contact X

1. P J Schweitzer Co Div. of Kimberly Clark Lee, MA 243-1000
Name St. & No. City/Town State Tel. No.

2. _____
Name St. & No. City/Town State Tel. No.

3. _____
Name St. & No. City/Town State Tel. No.

3. Caretaker [if any] e.g. superintendent, plant manager, appointed by absentee owner, appointed by multi owners.
William Henning Lee, MA 243-1000
Name St. & No. City/Town State Tel. No.

4. No. of Pictures taken 11

5. Degree of Hazard: [if dam should fail completely]*
1. Minor _____ 2. Moderate X
3. Severe _____ 4. Disastrous _____

*This rating may change as land use changes [future development]

6. Outlet Control: Automatic _____ Manual X
Operative X yes _____ no.

Comments: _____

upstream face of Dam: Condition:
1. Good X 2. Minor Repairs _____
3. Major Repairs _____ 4. Urgent Repairs _____

Comments: _____

1. 100 A

- 2 -

DAM NO. 1-2-150-11

2. Downstream Face of Dam: Condition: 1. Good____. 2. Minor Repairs____.
3. Major Repairs X 4. Urgent Repairs____.

Comments: _____

9. Emergency Spillway: Condition: 1. Good____. 2. Minor Repairs X.
3. Major Repairs____. 4. Urgent Repairs____.

Comments: _____

10. Water level @ time of inspection: 0.3 ft. above____. below X.
top of dam X.
principal spillway____.
other_____.

11. Summary of Deficiencies Noted:
Growth [Trees and Brush] on Embankment_____
Animal Burrows and Washouts_____
Damage to slopes or top of dam X_____
Cracked or Damaged Masonry_____
Evidence of Seepage_____
Evidence of Piping_____
Erosion_____
Leaks_____
Trash and/or debris impeding flow_____
Clogged or blocked spillway_____
Other_____

12. Remarks & Recommendations: [Fully Explain]

This is the initial inspection of the structure. The inspection was made in the company of Mr. William Henning, Plant Engineer.

The concrete spillway cap and upstream face appear to be in good condition. There is no evidence of cracks or spalling. The stone masonry abutment are in good shape. The easterly section of the plank apron has pulled away from the abutment and concrete cap about six inches, and the apron has dropped about three inches. The movement has occurred over a period of several years and appears to have stabilized. In general, the timber planking is in good shape. A few broken timbers should be replaced. However, the center section of the apron is badly damaged (see photos). The vertical timbers at the center have been displaced, allowing movement in the rock fill. The movement has forced the apron planks upwards. This area should be repaired to prevent further damage.

Mr. Henning informed me that the company has retained a consultant to recommend repairs. The recommendations will be forwarded at a later date.

13.

Overall Condition:

1. Safe _____.
2. Minor repairs needed X _____.
3. Conditionally safe - major repairs needed _____.
4. Unsafe _____.
5. Reservoir impoundment no longer exists [explain]
Recommend removal from inspection list _____.

L-165

DESCRIPTION OF DAM

DISTRICT ONE

Submitted by RDJordan

Dam No. 1-2-150-11

Date August 14, 1974

City/Town LEE

Name of Dam Valley Mill

1. Location: Topo Sheet No. S-C

Provide 8-1/2" x 11" in clear copy of topo map with location of Dam clearly indicated.

2. Year built: unknown Year/s of subsequent repairs 1961

3. Purpose of Dam: Water Supply _____, Recreational _____, Irrigation _____, Other Fire Protection

4. Drainage Area: 168 sq. mi. _____ acres.

5. Normal Ponding Area: 65 6a5 Acres; Avg. Depth _____, Impoundment: _____ gals; _____ acre ft.

6. No. and type of dwellings located adjacent to pond or reservoir _____ i.e. summer homes etc. _____

7. Dimensions of Dam: Length 165' Max. Height 10', Slopes: Upstream Face conc cap & rock, Downstream Face timber crib-rock filled-plank apron, Width across top 2'

8. Classification of Dam by Material: Earth _____, Conc. Masonry _____, Stone Masonry _____, Timber X, Rockfill X, Other _____

9. A. Description of present land usage downstream of dam: _____ Rural; 100% Urban.

B. Is there a storage area or flood plain downstream of dam which could accommodate the impoundment in the event of a complete dam failure Yes _____, No X

L-159 A

DAM NO. 1-2-150-11

10. Risk to life and property in event of complete failure. Failure would cause flooding in the Town of Lee.

No. of people _____.

No. of homes _____.

No. of Businesses _____.

No. of Industries _____.

No. of Utilities _____.

Railroads _____.

Other dams _____.

Other _____.

Type _____.

Type _____.

11. Attach Sketch of dam to this form showing section and plan on 8-1/2" x 11" sheet.

VALLEY MILL DAM

1-2-150-11

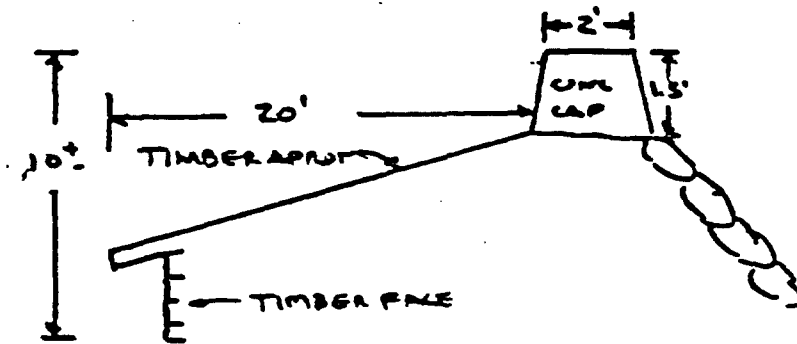
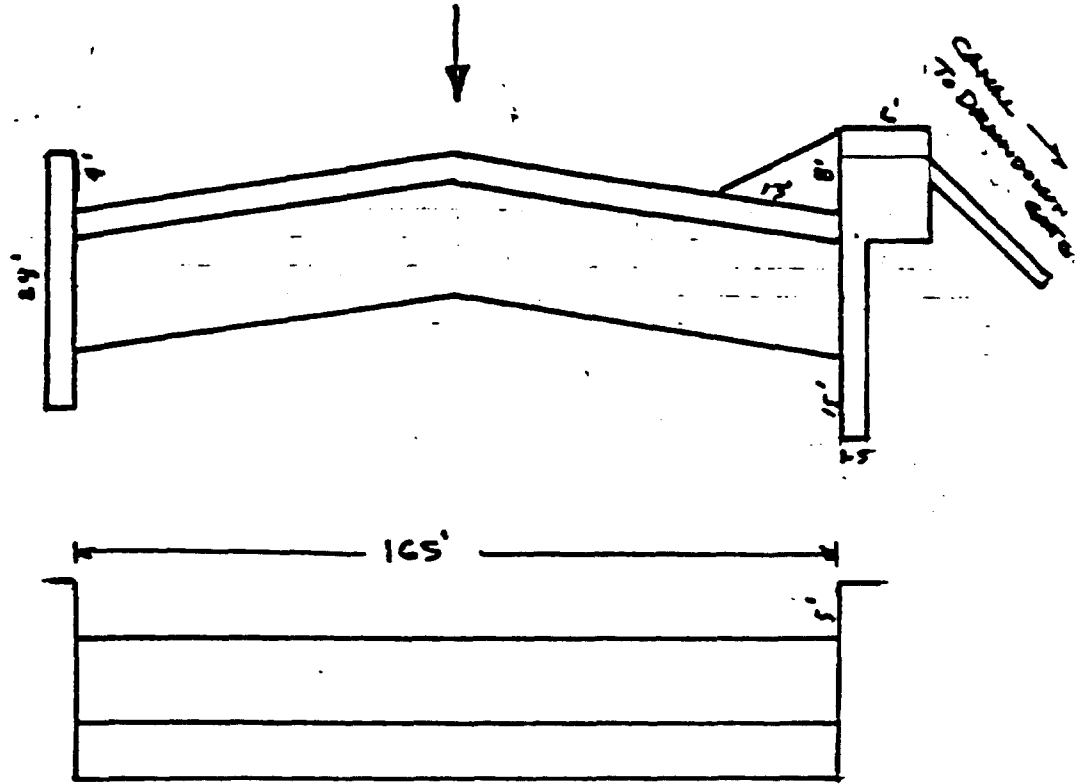

L-108

INSPECTION REPORT - DAMS AND RESERVOIRS

1. Location: ~~City~~/Town LEE Dam No. 1-2-150-11
Name of Dam Woods Pond (Valley Mill) Inspected by: RD Jordan
Date of Inspection 9-21-76

2. Owner/s: per: Assessors _____ Prev. Inspection X
Reg. of Deeds _____ Pers. Contact _____

- 1. P.J. Schweitzer Co. Div. of Kimberly Clark Lee MA 243-1000
Name St. & No. City/Town State Tel. No.
- 2. _____
Name St. & No. City/Town State Tel. No.
- 3. _____
Name St. & No. City/Town State Tel. No.

3. Caretaker [if any] e.g. superintendent, plant manager, appointed by absentee owner, appointed by multi owners.
Name St. & No. City/Town State Tel. No.

4. No. of Pictures taken 8

5. Degree of Hazard: [if dam should fail completely]*
1. Minor _____ 2. Moderate X
3. Severe _____ 4. Disastrous _____

*This rating may change as land use changes [future development]

6. Outlet Control: Automatic _____ Manual X
Operative X yes _____ no _____

Comments: _____

upstream face of Dam: Condition:
1. Good X 2. Minor Repairs _____
3. Major Repairs _____ 4. Urgent Repairs _____

Comments: _____

8. Downstream Face of Dam: Condition: 1. Good _____ 2. Minor Repairs X
 3. Major Repairs _____ 4. Urgent Repairs _____

Comments: _____

9. Emergency Spillway: Condition: 1. Good _____ 2. Minor Repairs _____
 3. Major Repairs _____ 4. Urgent Repairs _____

Comments: _____

10. Water level @ time of inspection: 3" ft. above _____ below X
 top of dam X
 principal spillway _____
 other _____

11. Summary of Deficiencies Noted:

Growth [Trees and Brush] on Embankment _____
 Animal Burrows and Washouts _____
 Damage to slopes or top of dam _____ X
 Cracked or Damaged Masonry _____
 Evidence of Seepage _____
 Evidence of Piping _____
 Erosion _____
 Leaks _____
 Trash and/or debris impeding flow _____
 Clogged or blocked spillway _____
 Other _____

2. Remarks & Recommendations: [Fully Explain] PREVIOUS INSPECTION DATE: August 8, 1974

The gate and gate controls at the south end of the canal below the dam were completely rebuilt during the spring or 1976. Inspected the site several times during the construction and found the gate system satisfactory.

During September 1976, the owners drewdown Woods Pond in order to repair the plank apron of the dam. Many new planks were securely fastened to the apron. This work corrected most of the deficiencies noted in 1974.

The section that has been damaged by the upward movement of the internal timbers has not been repaired, however, the company intends to remedy this situation next year.

No other deficiencies were noted.

For location see Topo Sheet 5-C.

13. Overall Condition:

1. Safe _____.
2. Minor repairs needed _____.
3. Conditionally safe - major repairs needed _____.
4. Unsafe _____.
5. Reservoir impoundment no longer exists [explain]
Recommend removal from inspection list _____.

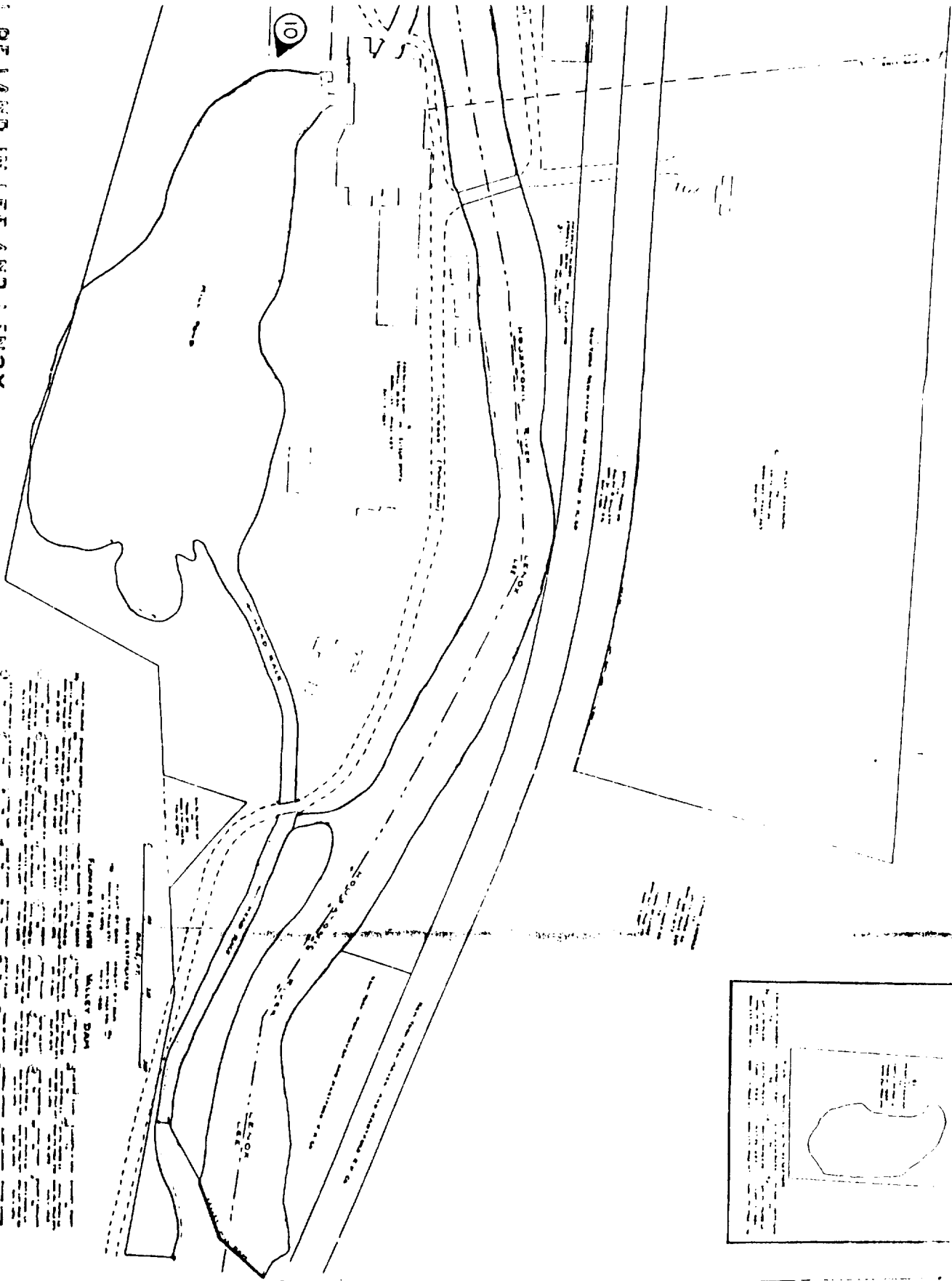
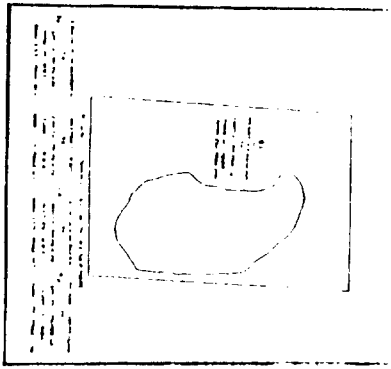

1 OF LAND IN LEE AND SINOX

OWNED BY SMITH PAPER INC.

VALLEY MILL PROPERTY

Map scale and other technical specifications.

Detailed descriptive text and notes at the bottom of the page, including property details and survey information.

APPENDIX C - PHOTOGRAPHS

	<u>Page</u>
<u>LOCATION PLAN</u>	
Site Plan Sketch	C-1

PHOTOGRAPHS

<u>No.</u>	<u>Title</u>	<u>Roll</u>	<u>Frame</u>	<u>Page</u>
1.	Overview of Woods Pond (Valley Mill) Dam taken in April 1979	A1	10A	vi
2.	Spillway and right abutment of dam	16	11	C-2
3.	Right bank of reservoir area immediately upstream of dam	C38	12	C-2
4.	Spillway, left abutment and entrance to head race canal	17	1	C-3
5.	Concrete wall protects upstream end of island between spillway and head race canal (taken in November 1978)	C32	5	C-3
6.	Left stone masonry wall at entrance to head race canal	C38	1	C-4
7.	Access bridge and gate house at regulating outlet	16	17	C-4
8.	Substructure and slide gates at regulating outlet	C38	8	C-5
9.	Concrete training walls at regulating outlet	C38	7	C-5
10.	Makeshift rubble spillway at outlet from mill pond	C38	22	C-6
11.	Housatonic River channel downstream of dam	C38	18	C-6

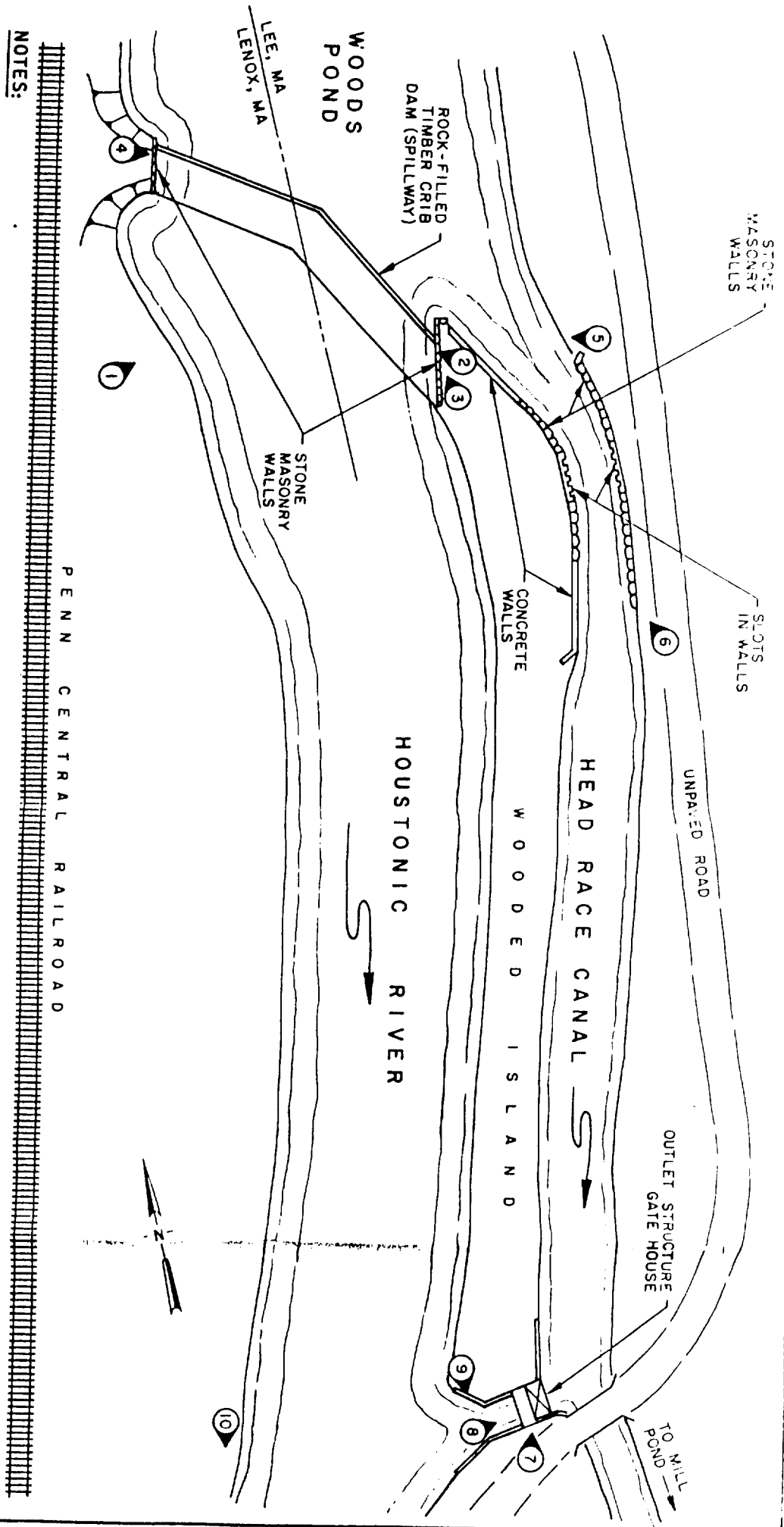

- NOTES:**
1. PLAN DEVELOPED FROM ROUGH MEASUREMENTS AND VISUAL OBSERVATIONS MADE ON 30 MAY 1979.
 2. SEE PAGE B-11 FOR LOCATION OF PHOTO NO. 10

LEGEND

7 PHOTO NO. AND DIRECTION OF VIEW

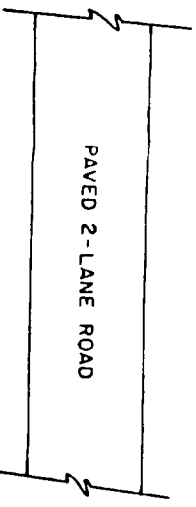

Woods Pond (Valley Mill) Dam
Lee-Lenox, MA

SITE PLAN SKETCH

HALEY & ALDREDGE, INC.
CAMBRIDGE, MASS

Approx. Scale: 1" = 50'
July, 1979



2. Spillway and right abutment of dam



3. Right bank of reservoir area immediately upstream of dam



4. Spillway, left abutment and entrance to head race canal



5. Concrete wall protects upstream end of island between spillway and head race canal (taken in November 1978)



6. Left stone masonry wall at entrance to head race canal



7. Access bridge and gate house at regulating outlet



8. Substructure and slide gates at regulating outlet



9. Concrete training walls at regulating outlet



10. Makeshift rubble spillway at outlet from mill pond



11. Housatonic River channel downstream of dam

APPENDIX D - HYDROLOGIC AND HYDRAULIC COMPUTATIONS

<u>Subject</u>	<u>Page</u>
Drainage Area and Failure Flood Impact Area Map	D-1
Size Classification, Hazard Potential, and Test Flood Development	D-2
Surcharge Storage Routing	D-3
Stage-Discharge at Woods Pond Dam	D-4
Area-Volume Curve #1	D-5
Area-Volume Curve #2	D-6
Stage-Discharge Downstream at Woods Pond Dam	D-7
Spillway Capacity	D-8
Spillway Capacity at Test Flood Pool	D-9
Dam Failure Analysis	D-10
Downstream Channel - Reach 1	D-10
Area-Volume Curve #3	D-11
Downstream Channel - Reaches 2 and 3	D-12
Failure Flood Impact	D-13
Housatonic River Profile	D-14
Downstream Channel Sectional Elevations and Stage-Discharge Curves	D-15

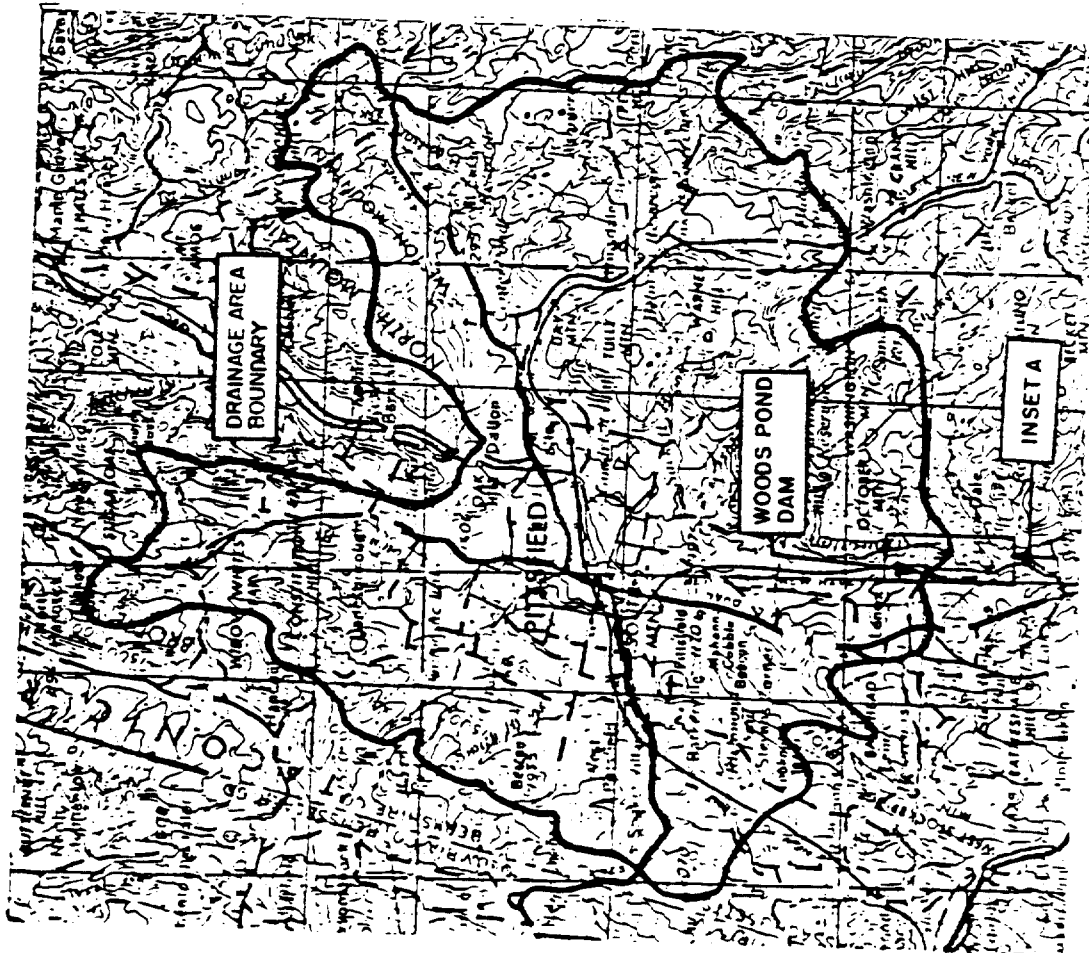

SCALE: 1:250,000

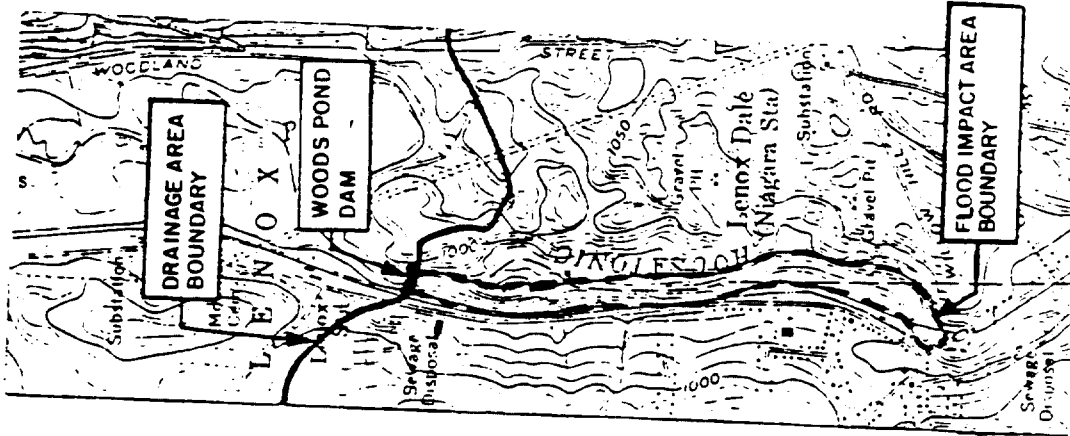

INSET A

SCALE: 1:24,000



WOODS POND DAM
DRAINAGE AREA AND
FLOOD IMPACT AREA
SCALE: AS SHOWN

CAMP DRESSER & MCKEE Inc.
Consulting Engineers
Boston, Mass.

CAMP DRESSER & MCKEE
Environmental Engineers
Boston, Mass.

CLIENT Maley and Aldrich
PROJECT COE Dam Inspections
DETAIL Woods Pond Dam - Lenox

JOB NO 561-9-R+-13
DATE CHECKED 7/22/79
CHECKED BY MLC

PAGE 1
DATE 6/22/79
COMPUTED BY RHS

Size Classification

Height = $952.3 - 940.4 = 11.9$ ft. < 40 ft. SMALL

Storage = 2,100 acre-feet at 952.3 > 1000 ft. INTERMEDIATE

Dam size classification: INTERMEDIATE

Hazard Potential Classification

The downstream development consists of single-family residences and several commercial enterprises. During a dam failure, a few of the downstream residences and businesses would be flooded. Because of the potential for loss of few lives and some property damage, the hazard potential classification is SIGNIFICANT

Test Flood Development

Size: Intermediate
Hazard: Significant $Q_T \approx \frac{1}{2}$ PMF to PMF

Drainage Area: 108,800 acres = 170.00 square miles

Land Topography: 55 % rolling terrain
39 % mountainous terrain
6 % flat, low-lying terrain

Peak Flow Rate: low lying terrain 350 cfs/sq. mi.
rolling terrain 825 cfs/sq. mi.
mountainous terrain 990 cfs/sq. mi. } (from COE curve)

$$Q_{PMF} = 170 \left((0.06 \times 350) + (0.55 \times 825) + (0.39 \times 990) \right) = 146,345 \text{ cfs}$$
$$= 860.85 \text{ cfs/sq. mi.}$$

Test Flood Flow: Use $\frac{1}{2}$ PMF
 $Q_{TEST} = 73,173 \text{ cfs} \approx 73,200 \text{ cfs}$

Surcharge Storage Routing

Test Flood inflow at Woods Pond = 73,173 cfs
WSE @ Woods Pond Dam @ 73,173 = 986.9' (See Stage-Discharge, page D-4)
Volume @ Woods Pond Dam @ 986.9 ft = 82,000 ac.-ft. (See Area-Vol., page D-5)

Normal Pond Volume @ 949.0 = 550 ac.-ft. (See Area-Vol. curve, page D-6)

$STOR_1 = \left(\frac{82,000 - 550}{108,800} \right) \times 12 = 9.0 \text{ in.}$
Trial $Q_2 = 73,173 \left(1 - \frac{9.0}{12} \right) = 3851 \text{ cfs} \rightarrow \text{WSE} = 956.5'$; Vol. = 8,000 ac.-ft.
 $STOR_2 = \left(\frac{82,000 - 550}{108,800} \right) \times 12 = 9.0 \text{ in.}$

$STOR_{av.} = 4.9 \text{ in.}$
 $Q_3 = 73,173 \left(1 - \frac{4.9}{12} \right) = 35,431 \text{ cfs} \rightarrow \text{WSE} = 973.1'$; Vol. = 36,000 ac.-ft.
 $STOR_3 = \left(\frac{82,000 - 550}{108,800} \right) \times 12 = 3.9 \text{ in.}$

$STOR_{av.} = 4.4 \text{ in.}$
 $Q_4 = 73,173 \left(1 - \frac{4.4}{12} \right) = 39,282 \text{ cfs} \rightarrow \text{WSE} = 974.9'$; Vol. = 42,000 ac.-ft.
 $STOR_4 = \left(\frac{82,000 - 550}{108,800} \right) \times 12 = 4.6 \text{ in.}$

$STOR_{av.} = 4.5 \text{ in.}$
 $Q_5 = 73,173 \left(1 - \frac{4.5}{12} \right) = 38,512 \text{ cfs} \rightarrow \text{WSE} = 974.4'$; Vol. = 40,000 ac.-ft.
 $STOR_5 = \left(\frac{82,000 - 550}{108,800} \right) \times 12 = 4.4 \text{ in.} \approx STOR_{av.}$

Test Flood Outflow = 38,500 cfs

Pond WSE = 974.4'

Test Flood WSE is 22.1' above top of dam

Tailwater

$Q = 38,500 \text{ cfs}$

WSE downstream from dam = 961.1' (See Stage-Discharge curve, page D-4)

Spillway elev. = 949.0

Spillway would be submerged by 12.1'

CAMP DRESSER & MCKEE
Environmental Engineers
Boston, Mass.

CLIENT Hayes and Aldrich
PROJECT COE Dam Inspections
DETAIL Woods Pond Dam - Lower

JOB NO. 561-9-R1-13
DATE CHECKED 10/10/79
CHECKED BY RLE

COMPUTED BY RHS
DATE 7/2/79
PAGE NO. 2

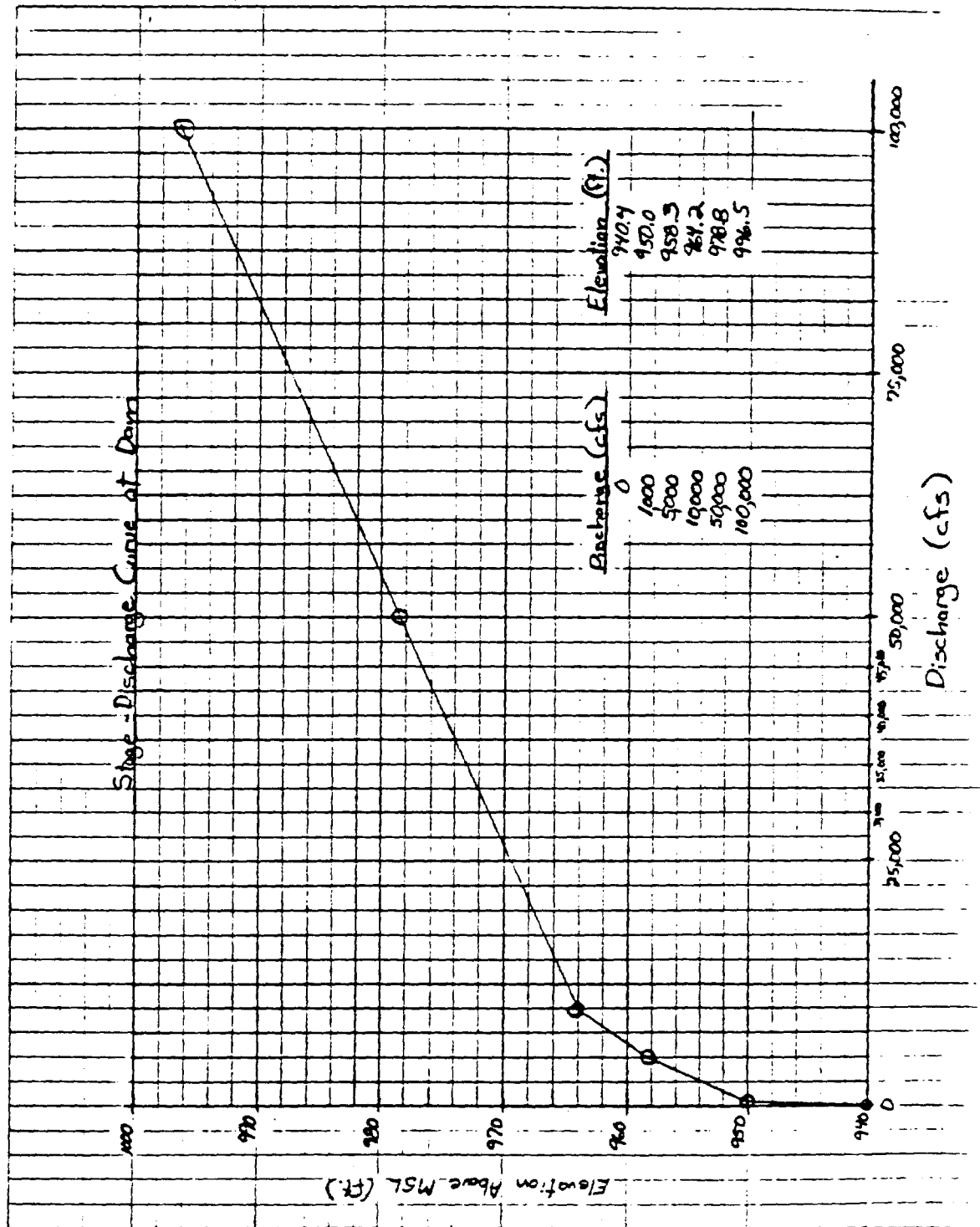

Area - Volume Curve #1
Woods Pond Dam

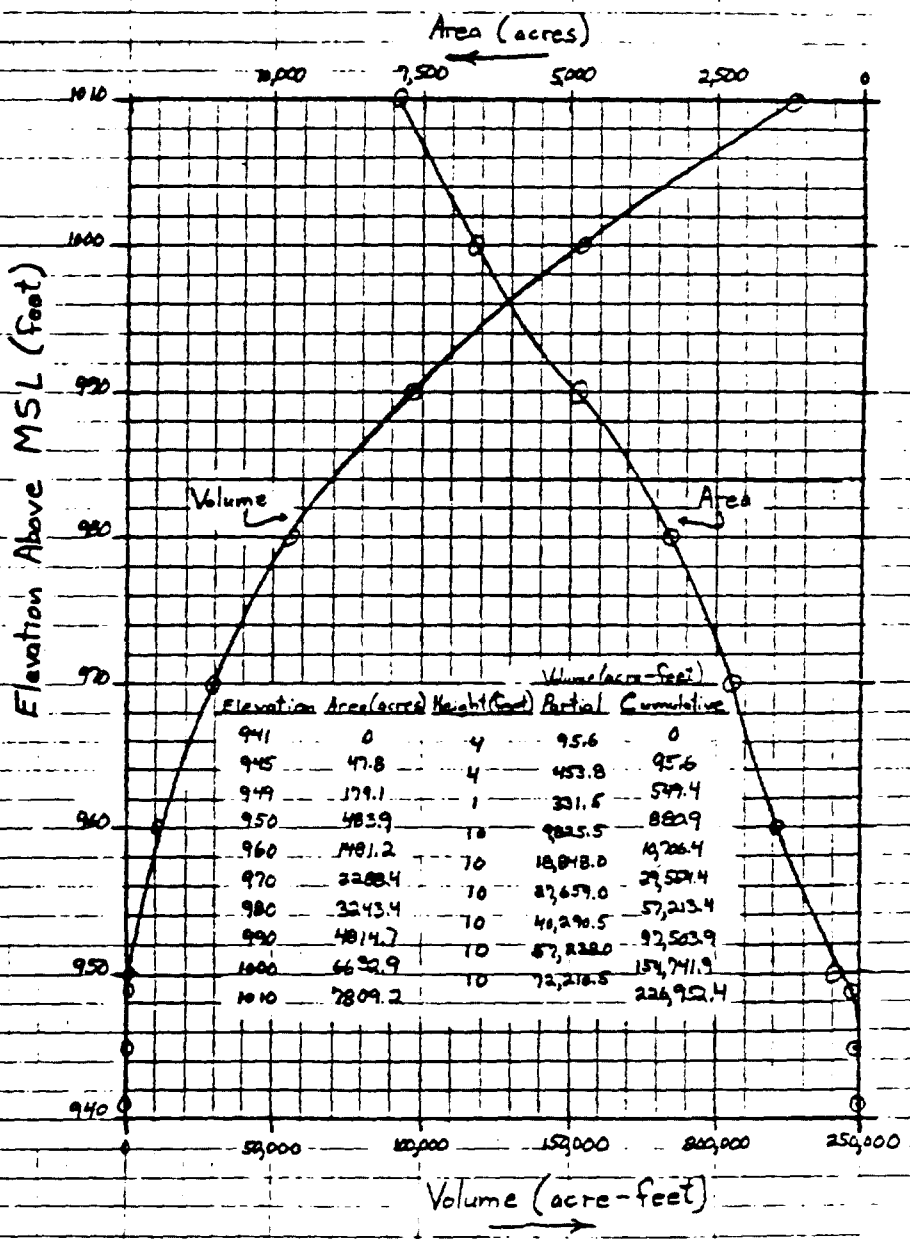

CAMP DRESSER & MCKEE
Environmental Engineers
Boston, Mass.

CLIENT Haley and Aldrich
PROJECT COE Dam Inspections
DETAIL Woods Pond Dam-Lenox

JOB NO 561-9-R1-13
DATE CHECKED 7/20/79
CHECKED BY AWG

PAGE 5
DATE 6/18/79
COMPUTED BY RMS

Area-Volume Curve #2

Elevation	Area (acres)	Height (ft)	Volume (acre-feet)	
			Actual	Cumulative
941	0	4	95.6	0
945	47.8	4	453.8	95.6
949	179.1	1	331.5	549.4
950	483.9			880.9

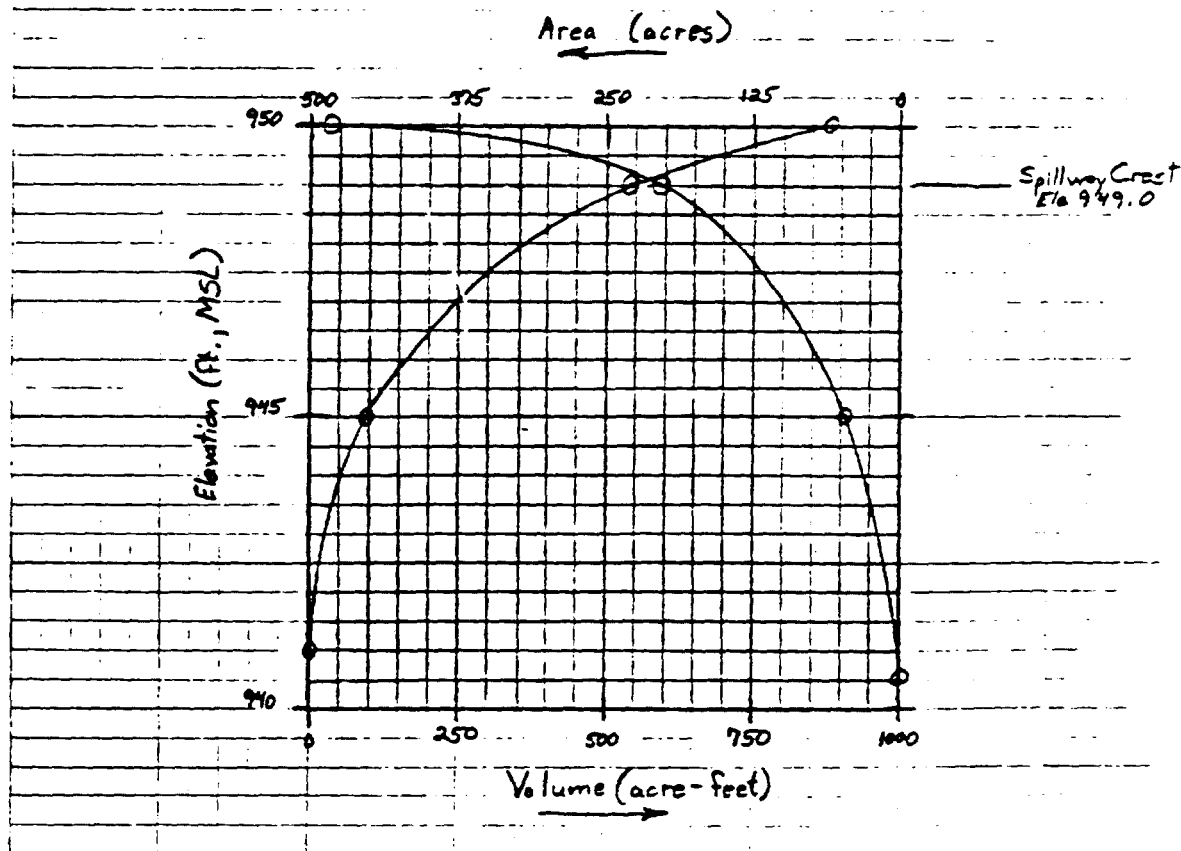

CAMP DRESSER & MCKEE
Environmental Engineers
Boston, Mass.

CLIENT Hoar, and Aldrich
PROJECT GOE Dam Inspection
DETAIL Woods Pond Dam - Lenox

JOB NO 541-9-R-13
DATE CHECKED 7/20/79
CHECKED BY FJS

COMPUTED BY RM
DATE 7/2/79
PAGE NO 2

Stage Discharge Curve
To Water at Dam

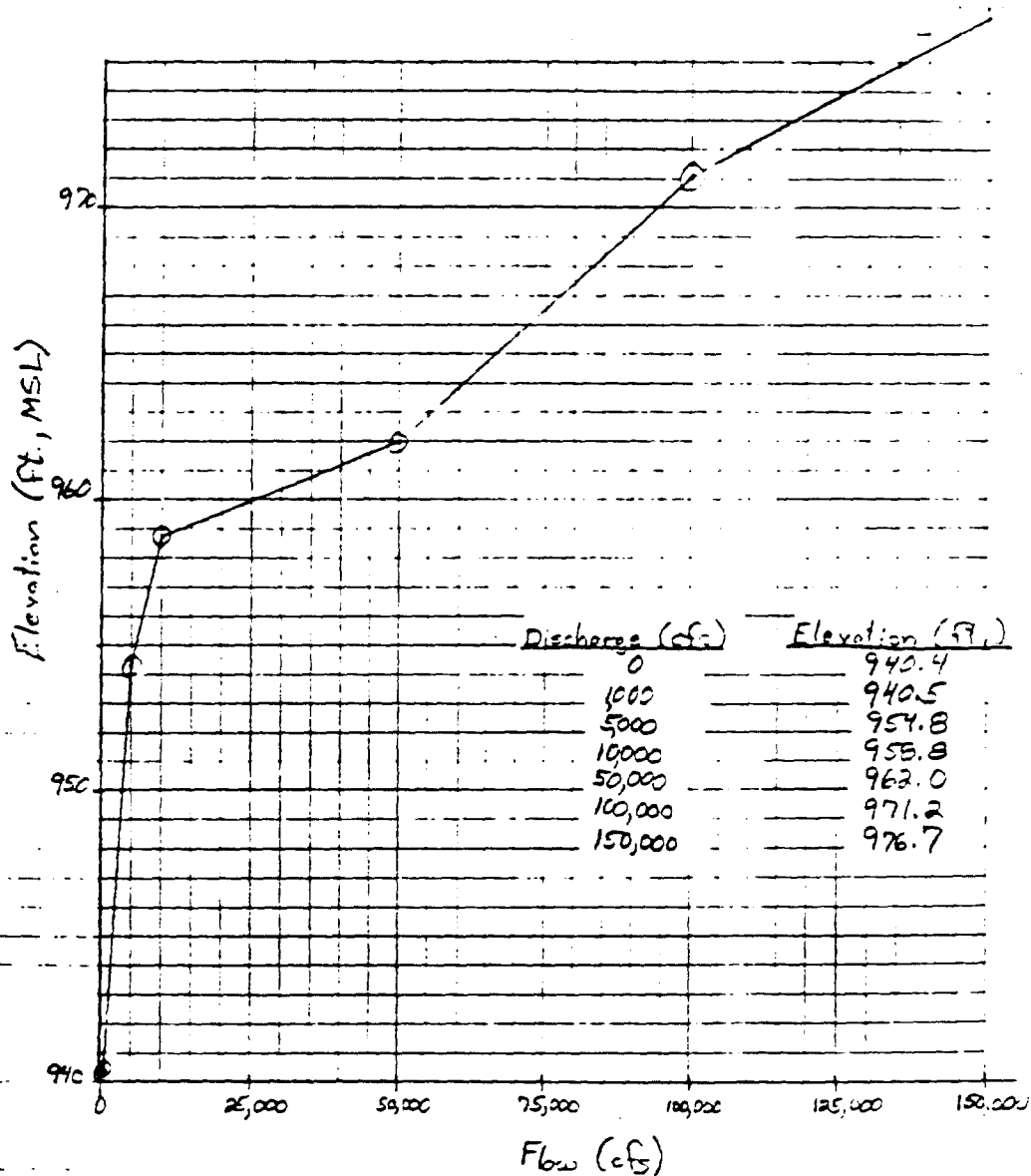

CAMP DRESSER & MCKEE
 Environmental Engineers
 Boston, Mass

CLIENT Moley and Aldrich
 PROJECT G&E Dam Inspections
 DETAIL Woods Pond Dam - Levee

JOB NO 561-0.5-13
 DATE CHECKED 7/10/77
 CHECKED BY ALL

PAGE 7
 DATE 7/10/77
 COMPUTED BY A.D.C.

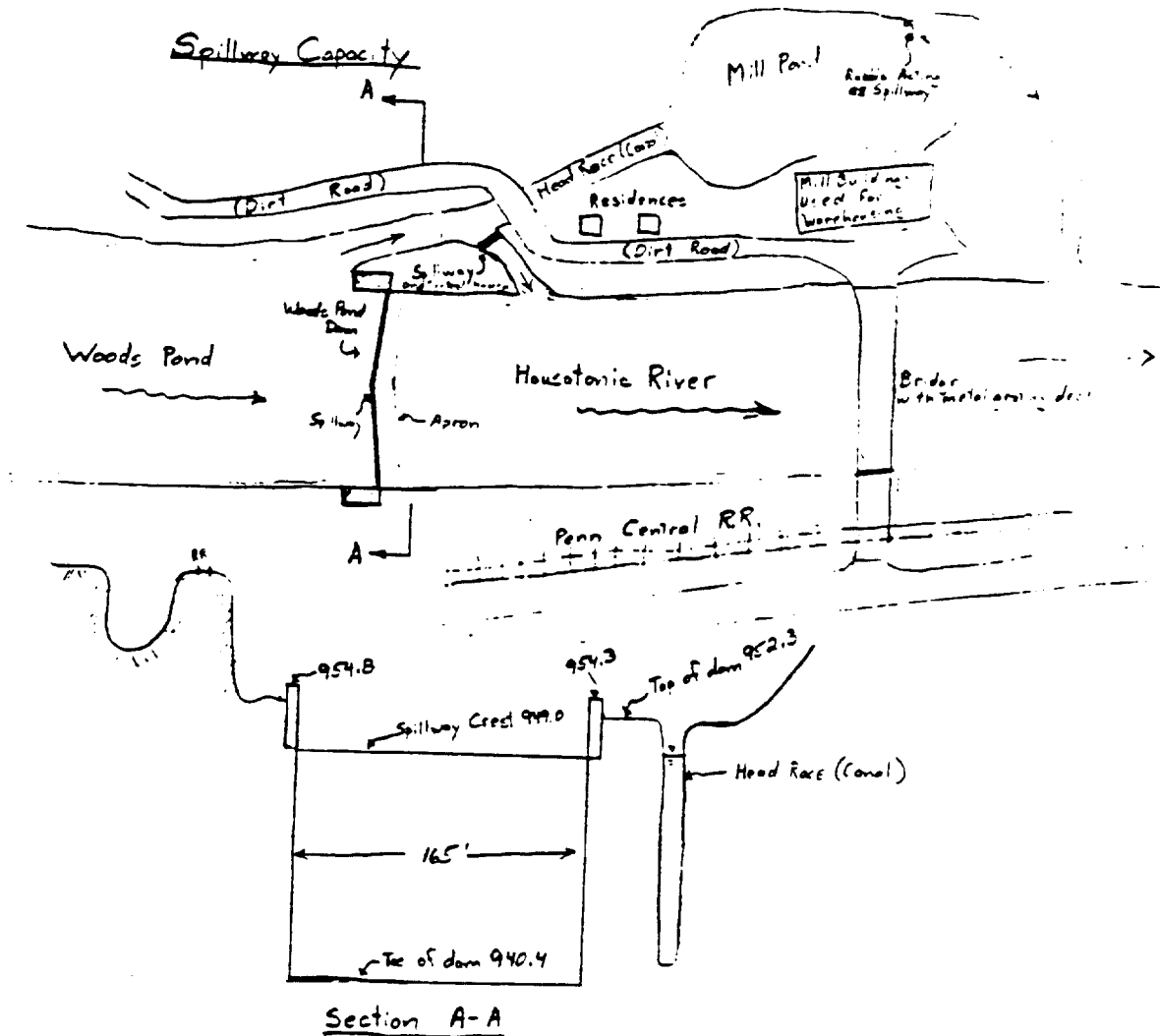

Capacity of spillway is calculated only for Woods Pond Dam

Using weir Formula:

$$Q = 3.5 \times L \times H^{3/2}$$

$$\text{At elevation } 952.3, Q = 3.5 \times 165 \times (952.3 - 949.0)^{3/2} = 3,462 \text{ cfs}$$

$$\frac{3462}{38,500} = 0.09 = 9\%$$

Spillway capacity is approximately 9% of the estimated test flood outflow.

CAMP DRESSER & MCKEE
Environmental Engineers
Boston, Mass

CLIENT Holt and Aldrich
PROJECT COE Dam Inspection
DETAIL Wards Pond Low-Lever

JOB NO 561-9-F-117
DATE CHECKED 7/2/77
CHECKED BY AME

PAGE 8
DATE 7/2/77
COMPUTED BY AME

Spillway Capacity of Test Flood Pool

^{Spillway}
 $Q = 3.5 \times 165 \times (974.4 - 961.1)^{1.5} = 28,011 \text{ cfs}$

Remainder would flow over banks.

$$\text{Remainder} = 38,500 \text{ cfs} - 28,011 \text{ cfs} = 10,489 \text{ cfs}$$

say 10,500 cfs

Dam Failure Analysis

$$Q_{p1} = \frac{8}{27} W_b \sqrt{g} Y_o^{3/2}$$

$$W_b = 0.90 \times 160 \text{ ft.} = 144 \text{ ft.} \quad (\text{stone masonry dam})$$

$$Y_o = \text{Total height from stream bed to pool level at top of the dam} = 952.3 - 940.4 = 11.9 \text{ ft.}$$

$$Q_{p1} = \frac{8}{27} \times 144 \times \sqrt{32.2} \times 11.9^{1.5} = 9939 \text{ cfs}$$

Flow in channel before failure = 2000 cfs (See Stage-Discharge Curve, page D-4)

Storage at failure = 2,200 ac.-ft. (See Area-Volume Curve, page D-10)

Downstream Channel

Reach 1: Woods Pond Dam to 2600 feet downstream (Sta 35+50)

$$Q_{p1} = 9939 \text{ cfs}$$

$$\text{Upstream Area} = 1904 \text{ sq. ft.}$$

$$\text{Downstream WSE} = 952.3$$

$$\text{Downstream Area} = 5100 \text{ sq. ft.}$$

$$V_1 = 2600 \left(\frac{5100 + 1904}{2} \right) \frac{1}{43560} = 209 \text{ ac.-ft.}$$

$$Q_{p2} (\text{trial}) = 9939 \left(1 - \frac{209}{2200} \right) = 8995 \text{ cfs} \rightarrow \text{WSE} = 952.3$$

$$V_2 \approx V_1 = V_{ave}$$

$$\text{Downstream Flow} = 8995 \text{ cfs @ WSE } 952.3$$

Area-Volume Curve #3

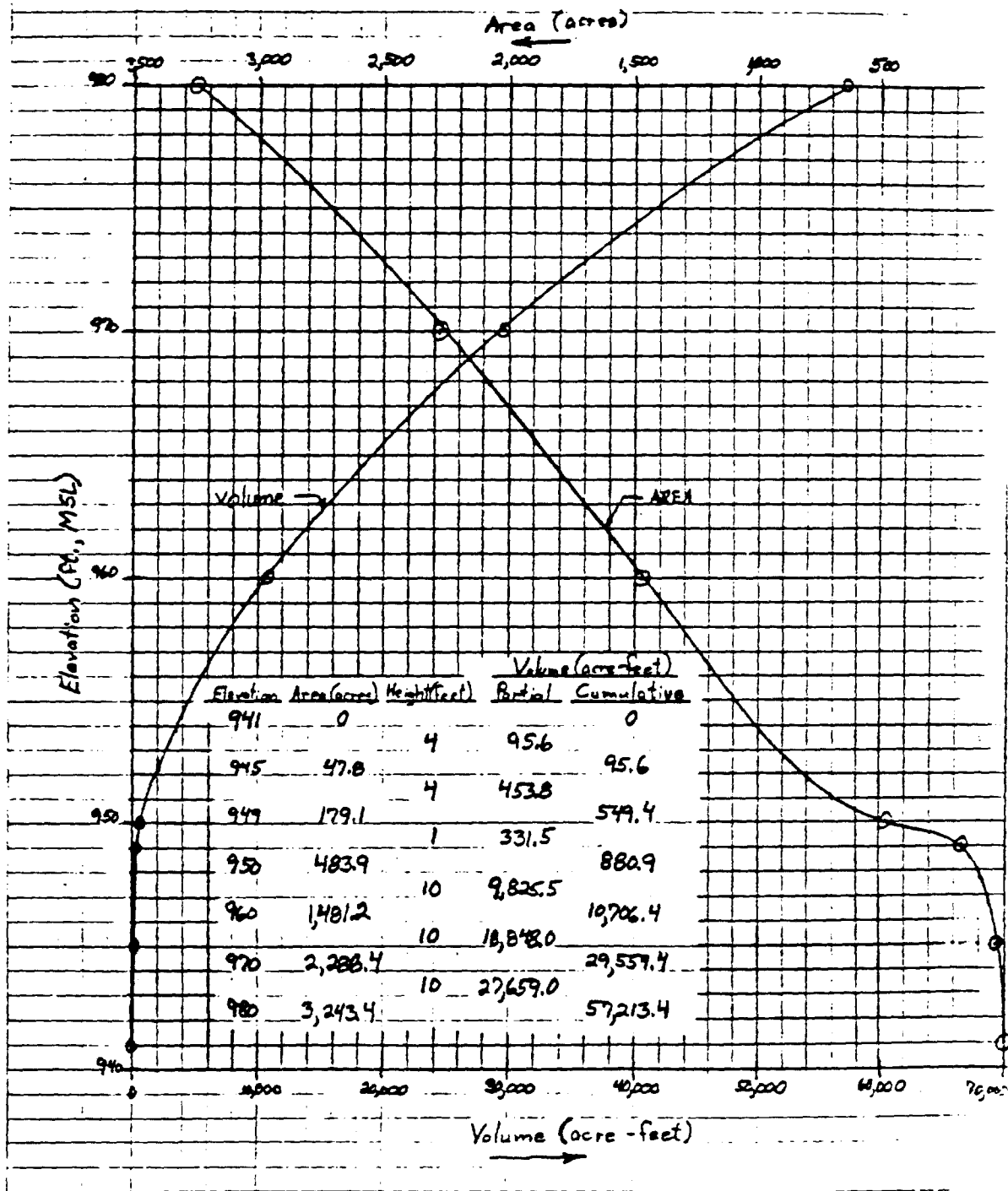

Reach 2: Sta 35+50 to Sta 3+50 (RR bridge)

Distance = 3200 ft.
 $S = 2200 - 209 = 1991 \text{ ac-ft}$
 $Q_{p1} = 8995$

Downstream Area = 1300 s.f.
 $V_1 = 3200 \left(\frac{500 + 800}{2} \right) \frac{1}{43500} = 235 \text{ ac-ft}$
 $Q_{p2}(\text{trial}) = 8995 \left(1 - \frac{235}{1991} \right) = 7933 \text{ cfs WSE} = 939.1; \text{Area} = 1250 \text{ s.f.}$

$V_2 = 3200 \left(\frac{500 + 1250}{2} \right) \frac{1}{43500} = 233 \text{ ac-ft}$
 $V_{ave} = 234 \text{ ac-ft}$
 $Q_{p2} = 8995 \left(1 - \frac{234}{1991} \right) = 7938 \text{ cfs} \rightarrow \text{WSE} = 939.5$

Downstream Flow = 7938 cfs @ WSE 939.5

Reach 3: Sta 3+50 to Sta 1+00 (Lenox Dale Bridge)

Distance = 200 ft.
 $S = 1991 - 234 = 1757 \text{ ac-ft}$
 $Q_{p1} = 7938 \text{ cfs}$

Downstream Area = 500 s.f.
 $V_1 = 200 \left(\frac{1250 + 500}{2} \right) \frac{1}{43500} = 4 \text{ ac-ft}$
 $Q_{p2}(\text{trial}) = 7938 \left(1 - \frac{4}{1757} \right) = 7920 \text{ cfs WSE} = 733.1$

$Q_{p2}(\text{trial}) \cong Q_{p1}$
 $\therefore V_1 \cong V_2 = V_{ave}$

Downstream Flow = 7920 @ WSE 733.1

Failure Flood Impact

A summary of potential flood impact from dam failure is shown below:

<u>Location</u>	<u>Description of Development</u>	<u>Depth of Flood Water (feet)</u>
Between Woods Pond Dam and downstream mill	Residential	2-4
	Warehouses	4
Lenox Dale	Sand and gravel business	2-4
	Residences between railroad and Housatonic River	2-4

An approximate hydraulic profile of a flood wave from dam failure is shown on page D-11.

CAMP DRESSER & MCKEE
Environmental Engineers
Boston, Mass.

CLIENT Holey and Aldrich
PROJECT GE Dam Inspections
DETAIL Woods Pond Dam - Lenox

JOB NO 561-9-94-12
DATE CHECKED 7/20/79
CHECKED BY MLG

PAGE 13
DATE 7/2/79
COMPUTED BY SM

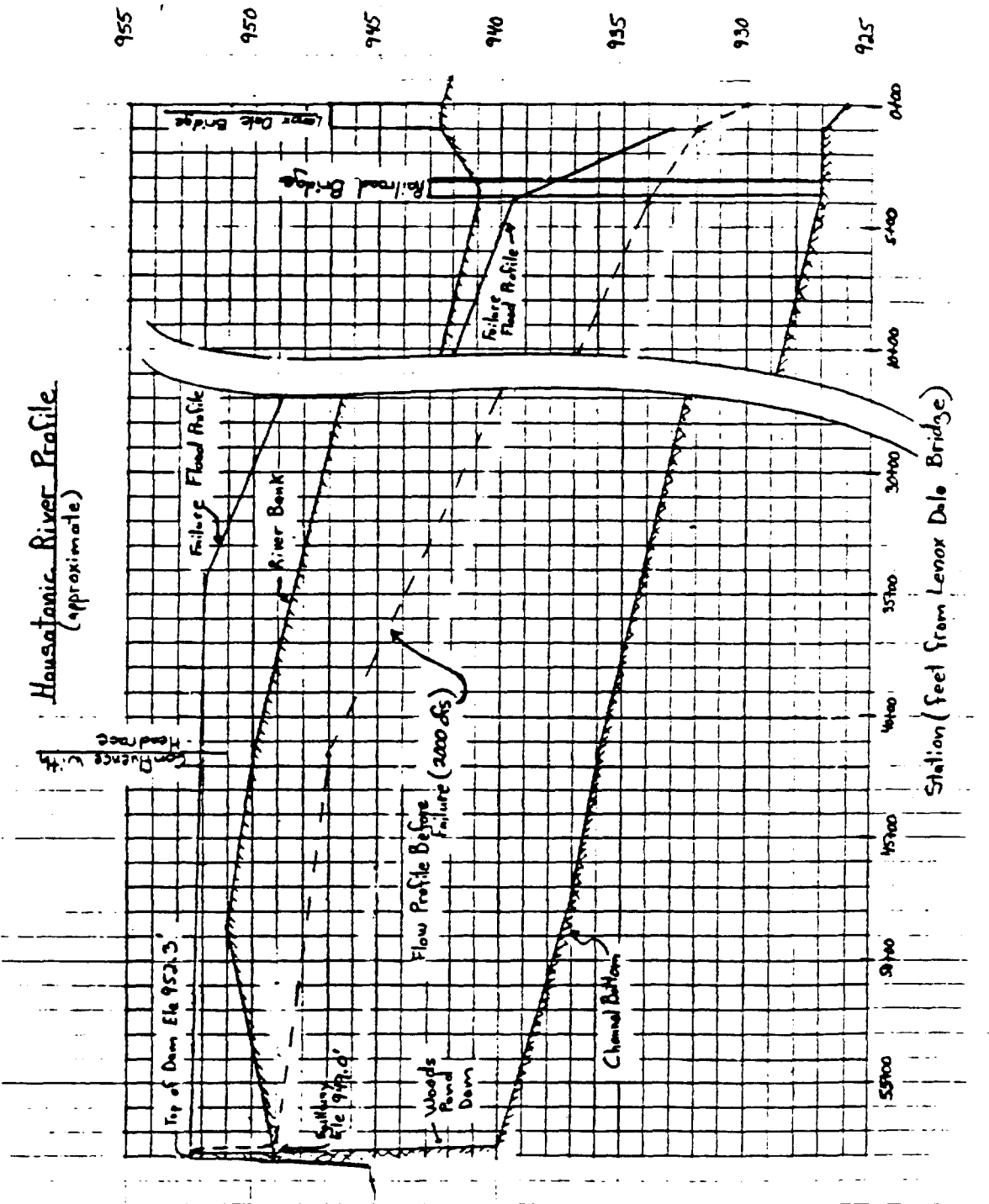

CAMP DRESSER & MCKEE
Environmental Engineers
Boston, Mass.

CLIENT Maly and Aldrich
PROJECT CDF Dam Inspection
DETAIL Woods Pond Dam - Lenox

JOB NO. 56-9-Rt-13
DATE CHECKED _____
CHECKED BY _____

COMPUTED BY RMS
DATE 6/25/77
PAGE NO. 1

Station 0+00 (Lenox Dale Bridge)
Cross-Section

Location: Downstream at Lenox Dale Bridge
Scale: Horizontal 1" = 250'
Vertical 1" = 10'
View: Looking Upstream

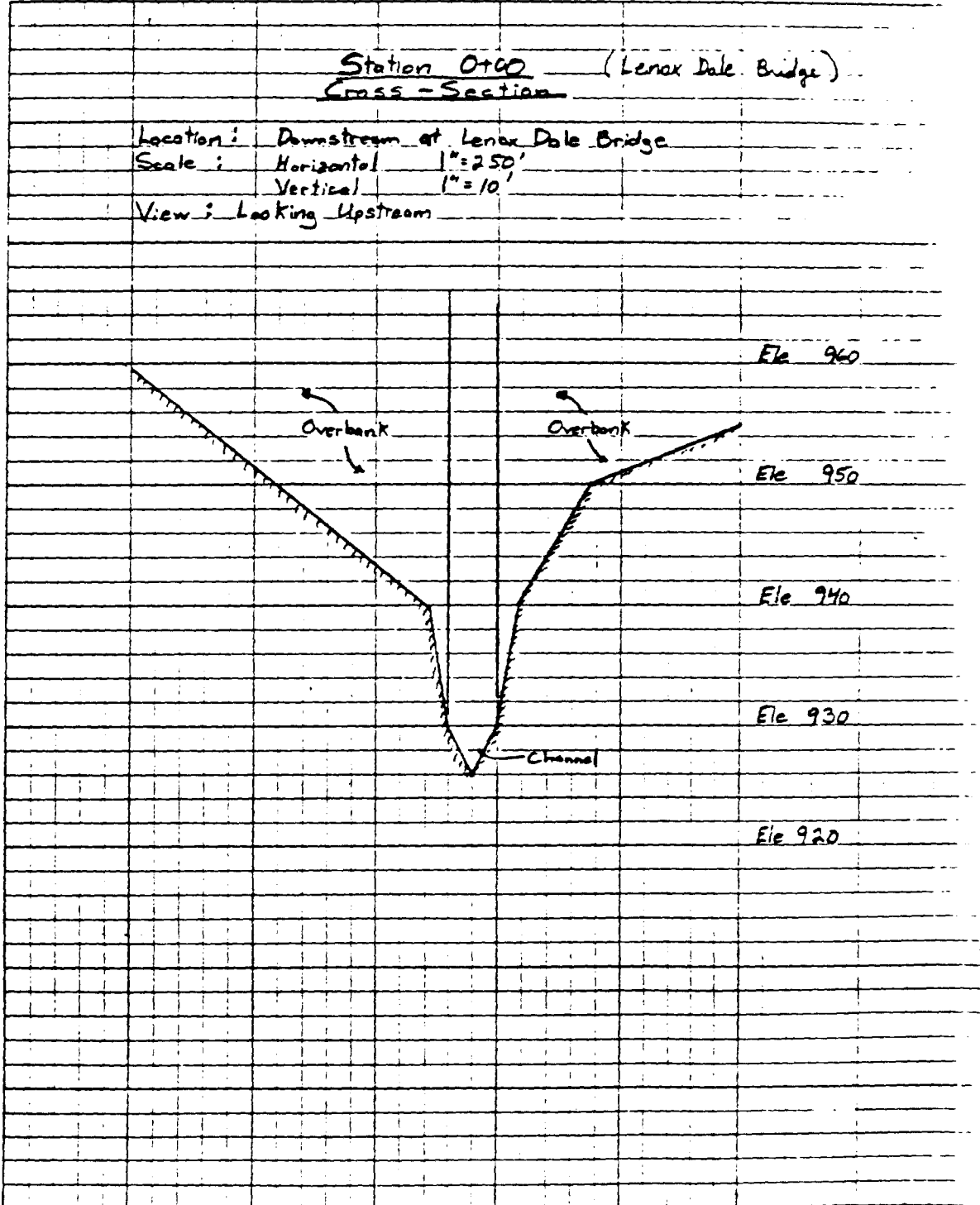

CAMP DRESSER & MCKEE
Environmental Engineers
Boston, Mass.

CLIENT Holey and Aldrich
PROJECT COE Dam Inspections
DETAIL Woods Pond Dam - Lenox

JOB NO 561-9-R1-B
DATE CHECKED _____
CHECKED BY _____

PAGE 2
DATE 6/27/79
COMPUTED BY RHS

Stage Discharge Curve Downstream from Lenox Dale Bridge
Station 0+00

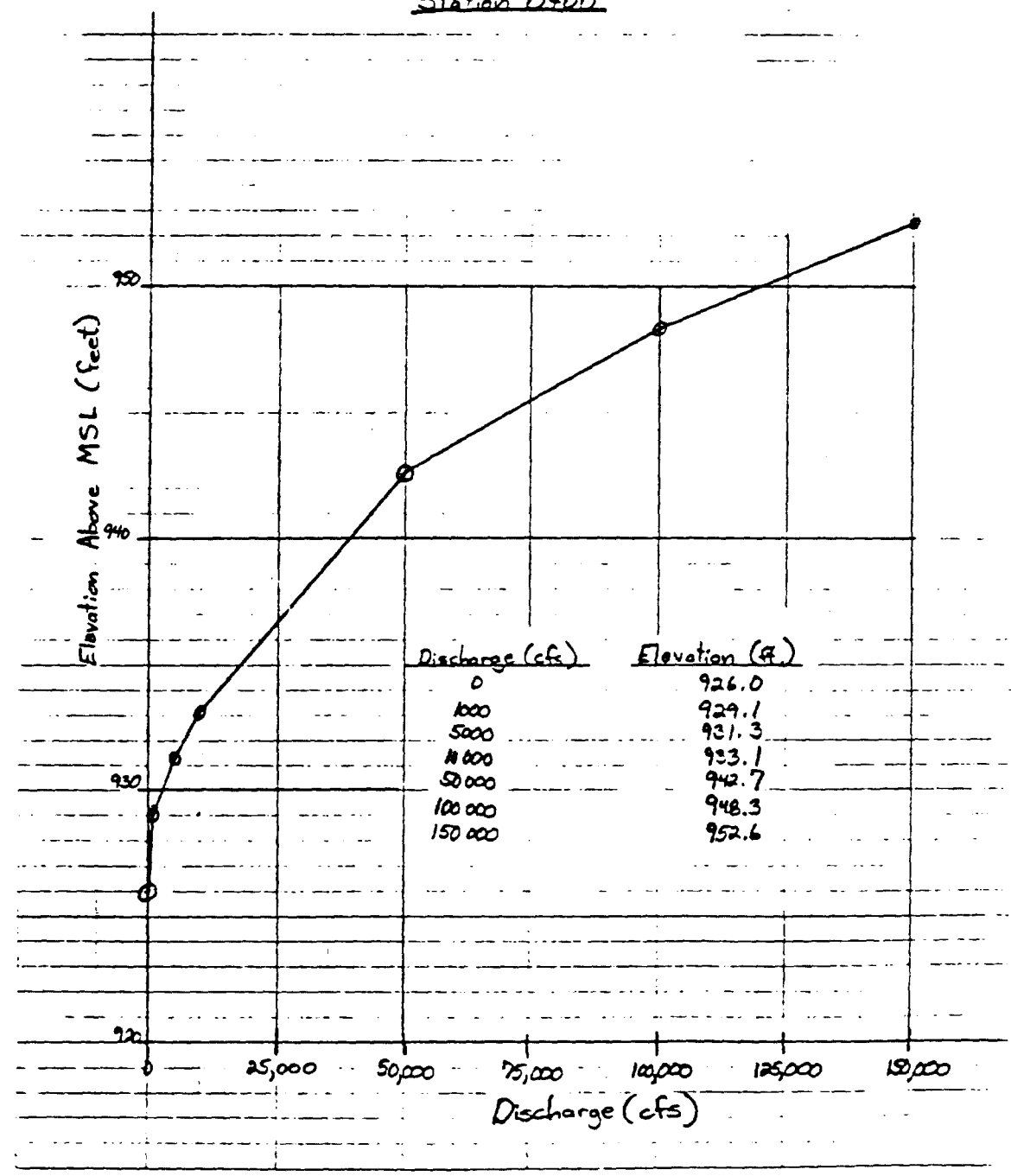

CAMP DRESSER & MCKEE
Environmental Engineers
Boston, Mass.

CLIENT Malley and Aldrich
PROJECT COE Dam Inspections
DETAIL Woods Pond Dam - Lenex

JOB NO. 561-9-R-13
DATE CHECKED _____
CHECKED BY _____

COMPUTED BY RHS
DATE 6/25/
PAGE NO 3

Station 1+00
Cross-Section

Location: Lenex Pole Bridge
Scale: Horizontal 1" = 50'
Vertical 1" = 10'
View: Looking Upstream

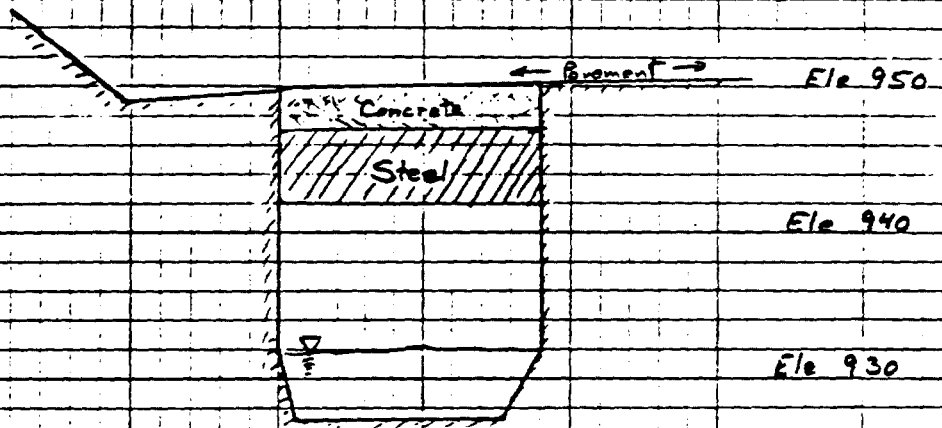

CAMP DRESSER & MCKEE
Environmental Engineers
Boston, Mass.

CLIENT Haley and Aldrich
PROJECT GOR Dam Inspection
DETAIL Woods Pond Dam - Levee

JOB NO 561-9-R-13
DATE CHECKED _____
CHECKED BY _____

PAGE 4
DATE 6/26/76
COMPUTED BY RHS

Stage - Discharge Curve at Station 1400

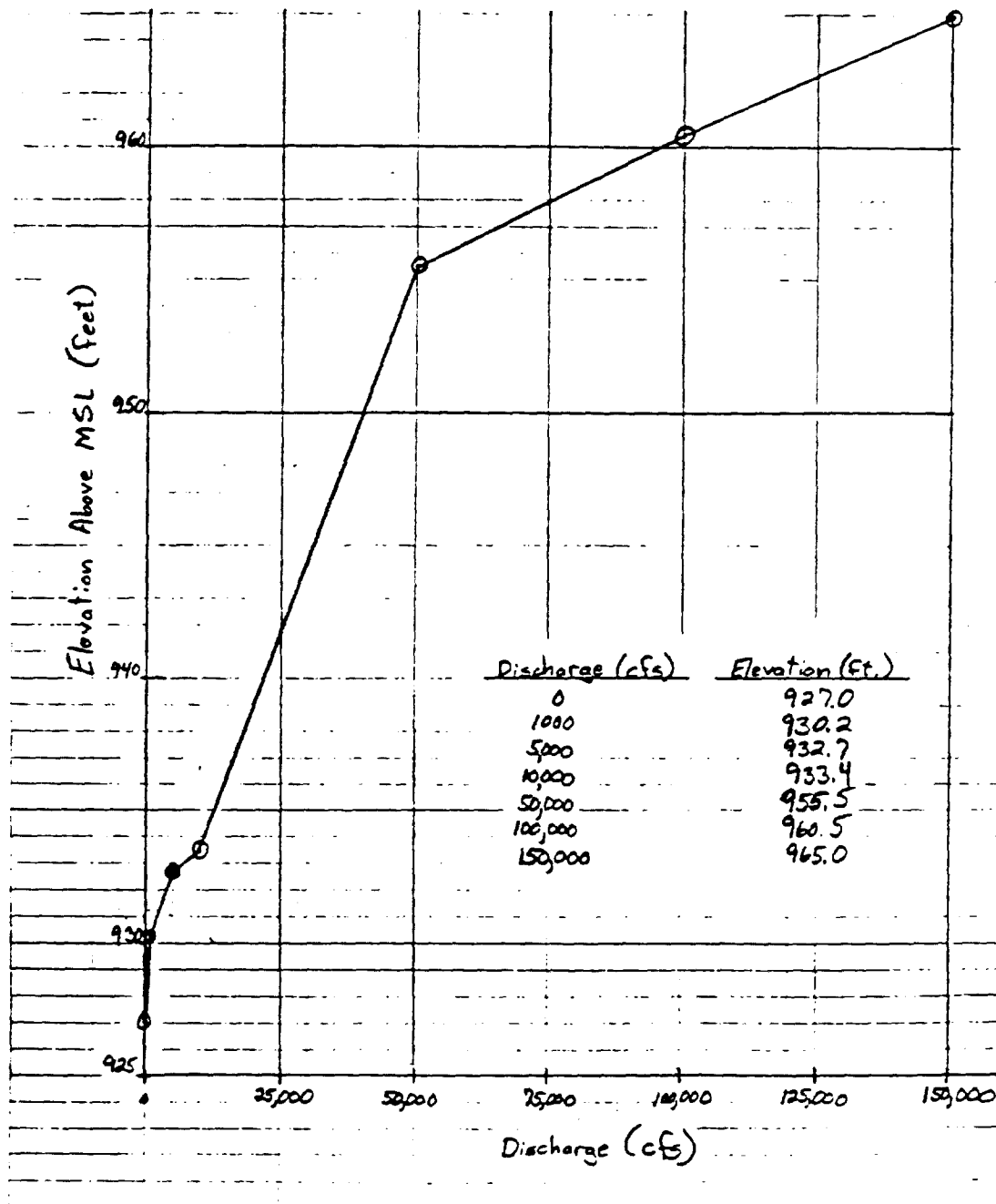

Station 3+50
Cross-Section

Location: At railroad bridge
 Scale: Horizontal 1" = 250'
 Vertical 1" = 10'
 View: Looking upstream

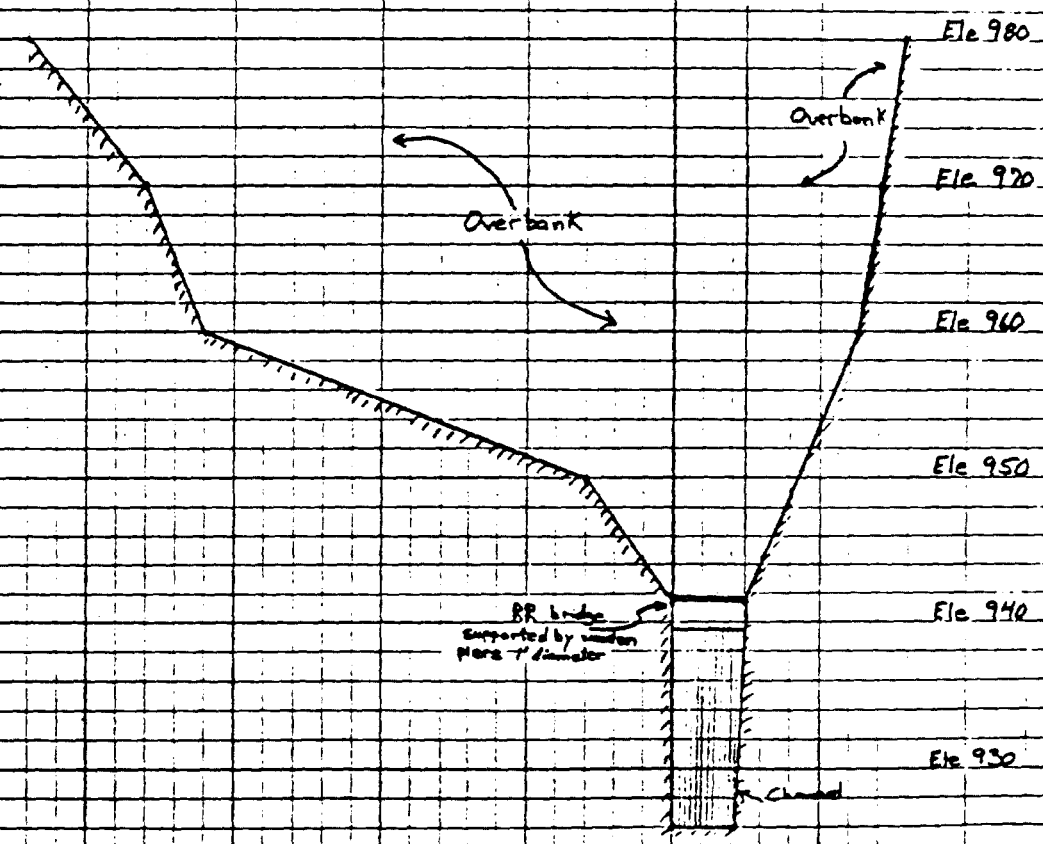

St. - Discharge Curve
Upstream from Railroad Bridge
Station 3+50

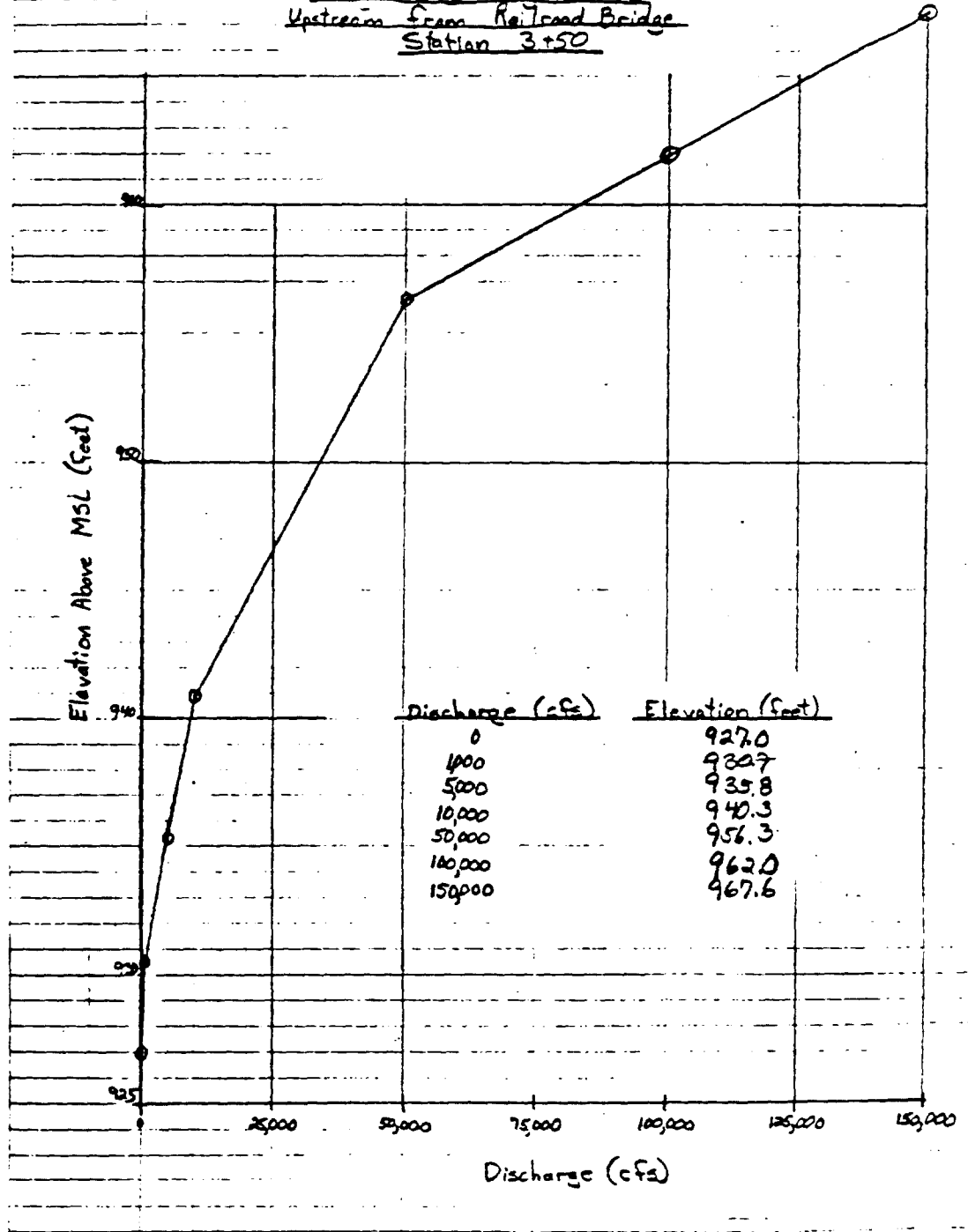

Station 41+50
Cross-Section

Location: Confluence of Head Race outlet and Housatonic River
Scale: Horizontal 1" = 250'
Vertical 1" = 10'
View: Looking Upstream

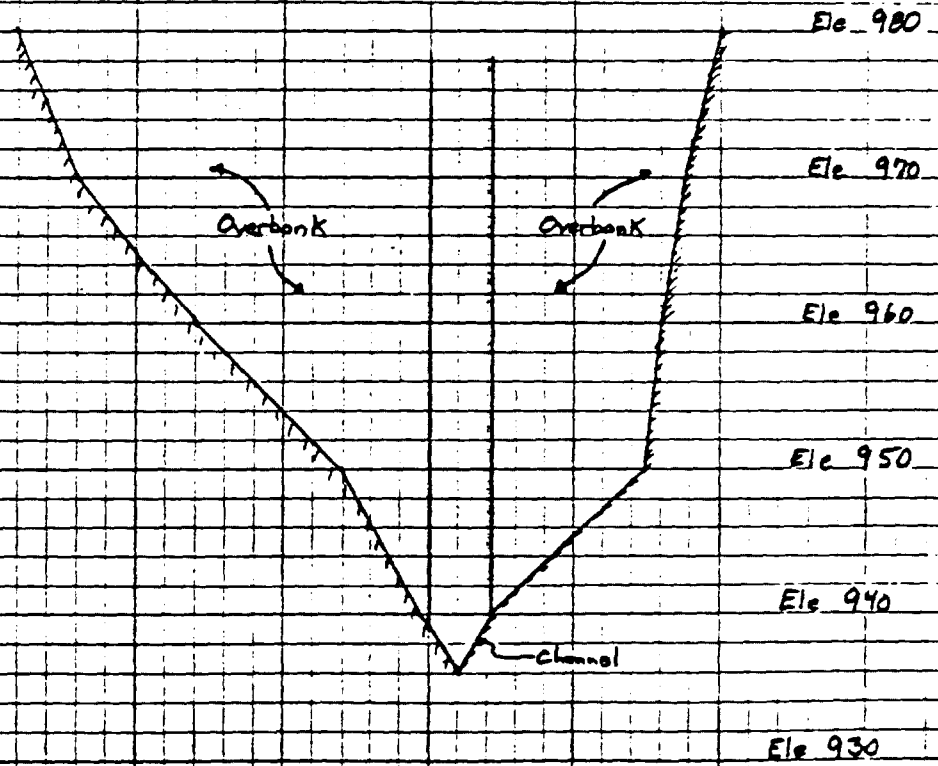

CAMP DRESSER & MCKEE
Environmental Engineers
Boston, Mass.

CLIENT Haly and Aldrich
PROJECT COC Dam Inspections
DETAIL Woods Pond Dam - Lenox

JOB NO 561-9-R1-13
DATE CHECKED _____
CHECKED BY _____

PAGE 8
DATE 6/29/79
COMPUTED BY RMS

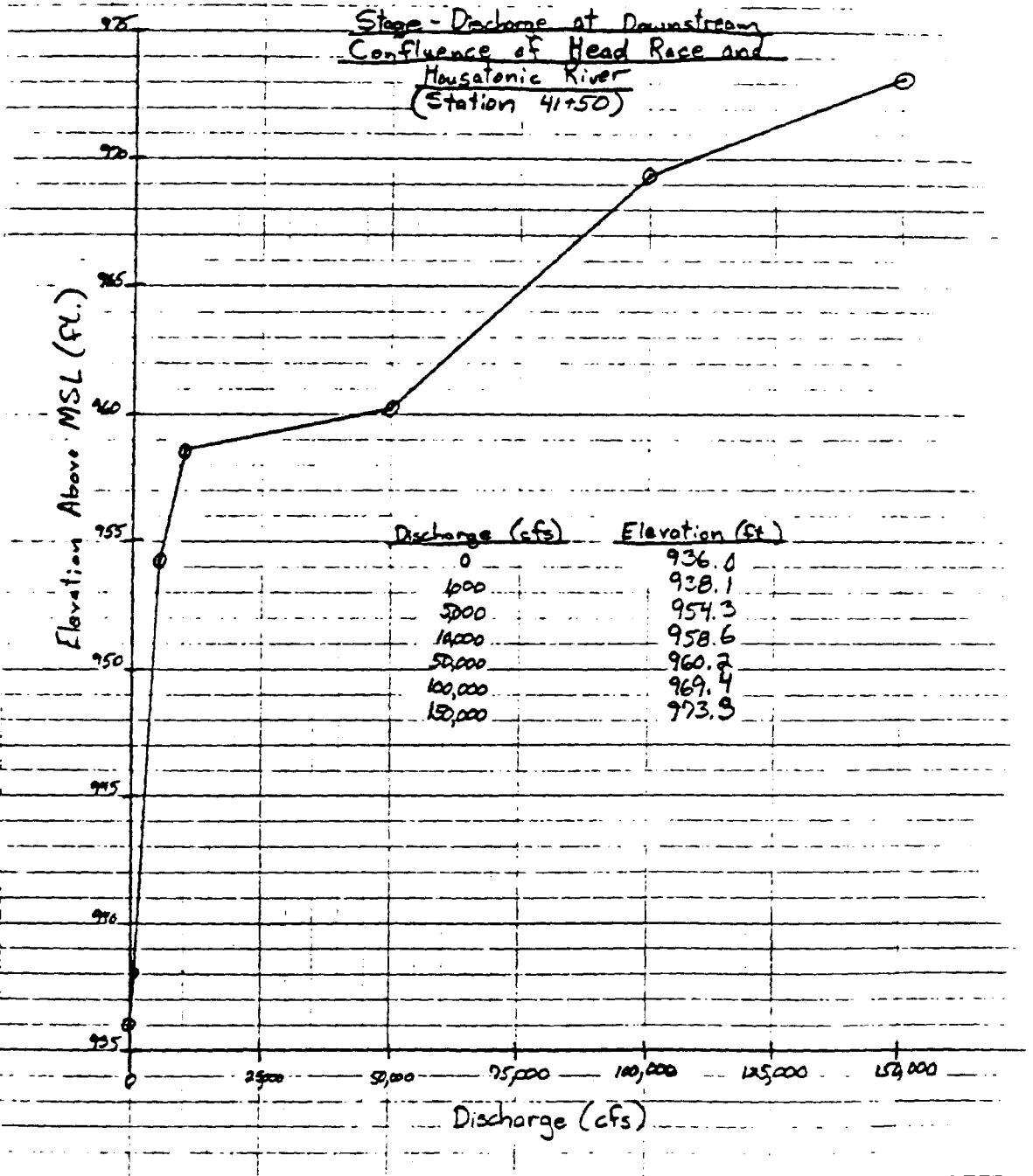

CAMP DRESSER & MCKEE
 Environmental Engineers
 Boston, Mass.

CLIENT Haley and Aldrich
 PROJECT CDE Dam Inspections
 DETAIL Wood-Pond Dam

JOB NO 561-A-Rt-13
 DATE CHECKED _____
 CHECKED BY _____

PAGE 9
 DATE 6/29/79
 COMPLETED BY RHS

Cross-Section Between Dam and Mill
 (Tailwater)

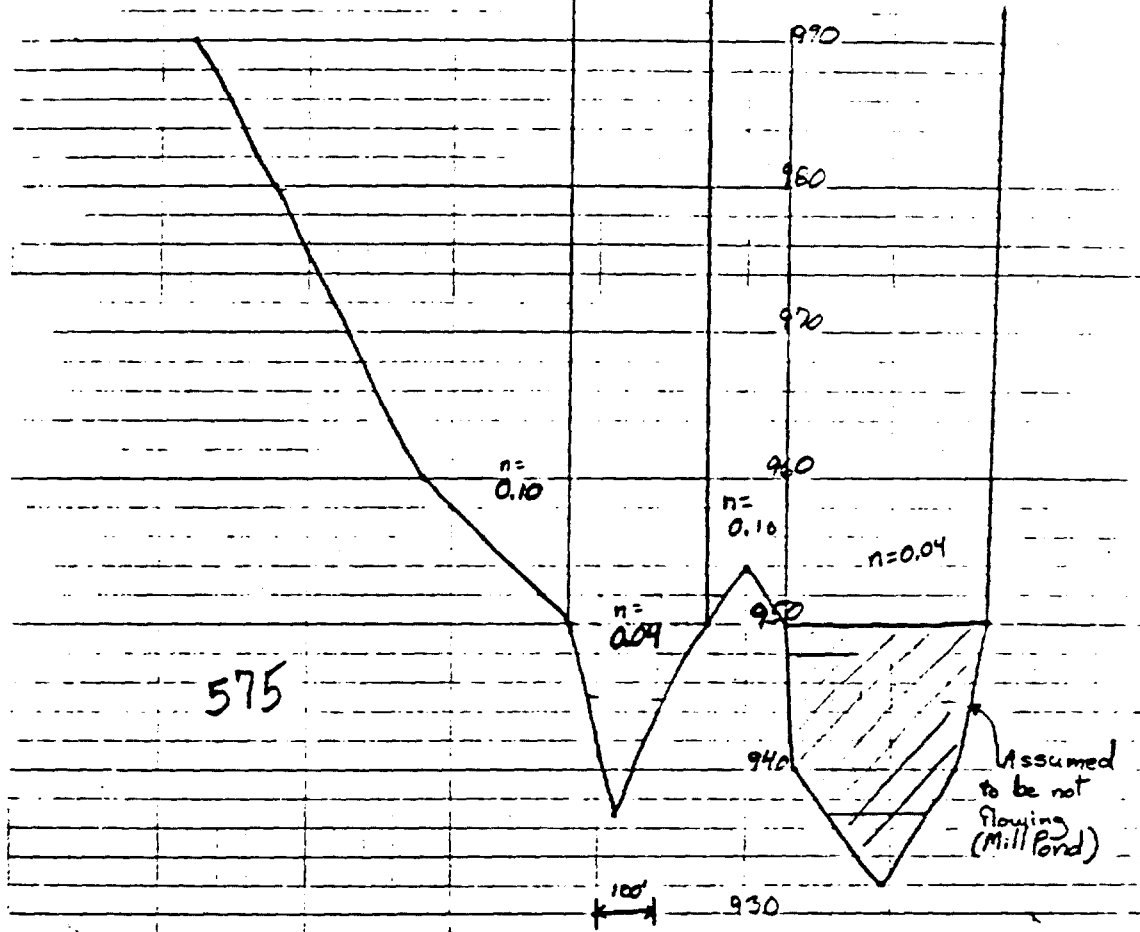

Ele	R _a	R _c	R _{TOTAL}	A _a	A _a *	A _c	Total Area	A _a ³
937							0	0
950		6.5	6.5			1495	1495	5206
970	12	20	32	6000	1494	12000	13494	136010
990	245	42.5	67	17750	4303	25495	29798	491555

* Equiv. Area = $A \frac{A}{R_c} \left(\frac{R_a}{R_c} \right)^3$

CAMP DRESSER & MCKEE
 Environmental Engineers
 Boston, Mass.

CLIENT Haley and Aldrich
 PROJECT COE Dam Inspection
 DETAIL Wood-Pond Dam-Levee

JOB NO. 721-1-1443
 DATE CHECKED 7/22/70
 CHECKED BY MLL

PAGE 10
 DATE 8/7/70
 COMPLETED BY S.

Stage-Discharge Downstream
at Station 47+50

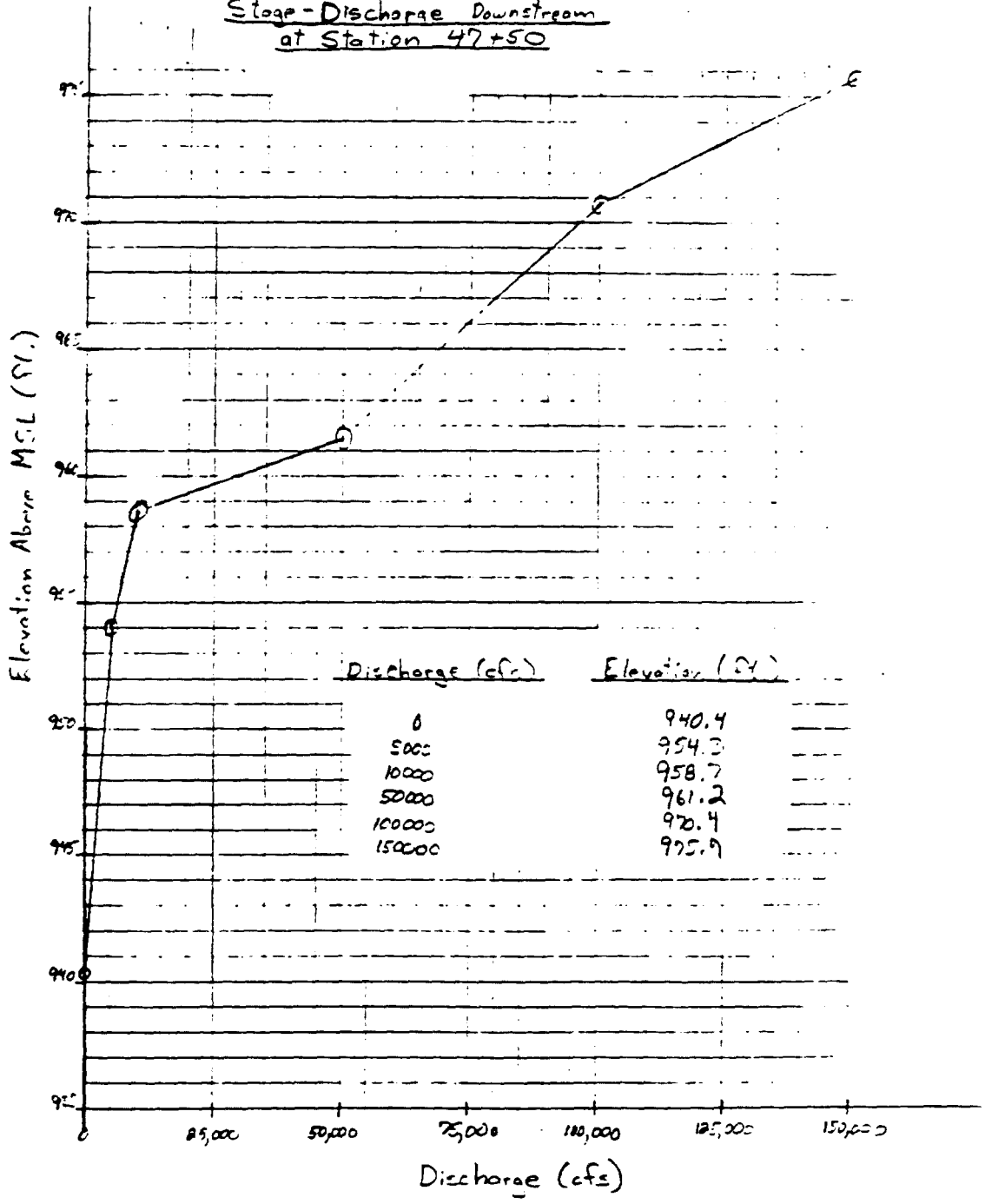

CAMP DRESSER & MCKEE
Environmental Engineers
Boston, Mass.

CLIENT Haley and Aldrich
PROJECT GEF Dam Inspection
DETAIL Woods Pond Dam - Lower

JOB NO 561-9-R-13
DATE CHECKED _____
CHECKED BY _____

COMPUTED BY f. h.
DATE 7/8/01
PAGE NO 1

Tailwater at Dam
Sectional Elevation
(Looking Westward)

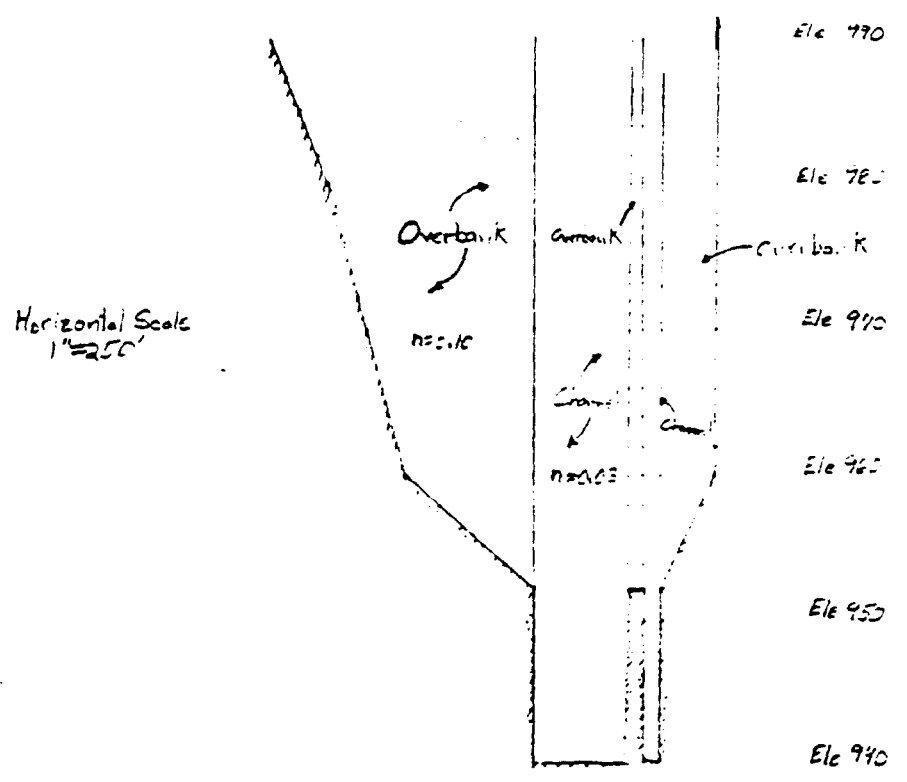

Elevation	R_u	R_c	R_{Toc}	A_u	A_c	A_c	Total Equiv. Area	$AR^{2/3}$	Q_{51}
940	-	-	-	-	-	-	-	0	0
952.4	-	10.9	10.9	-	-	2511	2511	12,344	4,115
960	4.3	17.2	21.5	1026	163	3955	4118	31,840	10,613
970	12.4	25.5	37.9	3726	922	5855	6777	76,461	25,487
980	19.0	33.7	52.7	7226	1973	7755	9728	136,735	45,578
990	26.3	42.0	68.3	10500	3074	9655	12729	212,699	76,596

CAMP DRESSER & MCKEE
Environmental Engineers
Boston, Mass

CLIENT Haley and Aldrich
PROJECT COE Dam Inspection
DETAIL Woods Pond Dam - Gen

JOB NO FE-9-R-3 COMPUTED BY SM
DATE CHECKED _____ DATE 11-2-59
CHECKED BY _____ PAGE NO 12

Computation Curve
for
 $S = 0.0001$
(COE "Method #1")

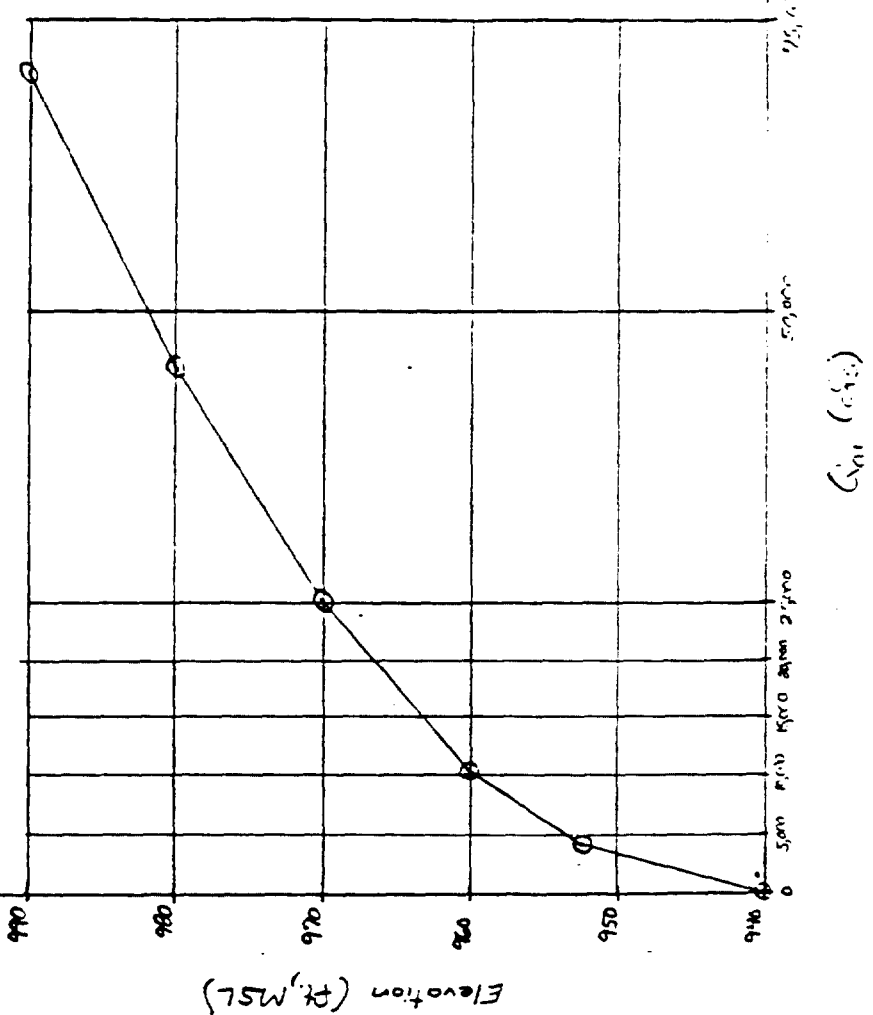

CAMP DRESSER & McKEE
Environmental Engineers
Boston, Mass

CLIENT Male, and Aldrich
PROJECT GDE Dam Inspections
DETAIL Woods Pond Dam - Levee

JOB NO 561-9-R-13
DATE CHECKED _____
CHECKED BY _____

COMPUTED BY J.H.
DATE 7/2/14
PAGE NO 13

For 1000 cfs

Downstream = 939.3 WSE

Distance to downstream section = 1000 ft.
Downstream $S = 0.00086$

Try Ele 940.7
 $Q_{01} = 250 \text{ cfs}$
 $S = 0.0016$
 $S_{ave} = 0.0012$
 $h_c = 1.2$
WSE = 940.5 close enough

For 5000 cfs

Downstream WSE = 954.3'

Downstream $S = 0.00086$

Try Ele = 955.0
 $Q_{01} = 6700 \text{ cfs}$
 $S = 0.0006$
 $S_{ave} = 0.00046$
 $h_c = 0.5$
WSE = 954.8 close enough

For 10,000 cfs

Downstream WSE = 958.7'

Downstream $S = 1.3 \times 10^{-5}$

Try Ele = 959.0
 $Q_{01} = 9300 \text{ cfs}$
 $S = 0.0001$
 $S_{ave} = 0.00006$
 $h_c = 0.1$
WSE = 958.8 close enough

CAMP DRESSER & MCKEE
Environmental Engineers
Boston, Mass

CLIENT Hailey and Aldrich
PROJECT GE Dam Inspections
DETAIL Woods Pond Dam - Lower

JOB NO 51-2-6-3
DATE CHECKED _____
CHECKED BY _____

COMPUTED BY JHC
DATE 5/2
PAGE NO 14

For 50,000 cfs

Downstream WSE = 961.2

Downstream $S = 0.00025$
Try WSE = 962.0
 $Q_{0.1} = 13,500 \text{ cfs}$
 $S = 0.0014$
 $S_{ave} = 0.0008$
 $h_c = 0.8$
WSE = 962.0

For 100,000 cfs

Downstream WSE = 970.4

Downstream $S = 0.00053$
Try WSE = 971
 $Q_{0.1} = 27,000 \text{ cfs}$
 $S = 0.0014$
 $S_{ave} = 0.0008$
 $h_c = 0.8$
WSE = 971.2 close enough

For 150,000 cfs

Downstream WSE = 975.9

Downstream $S = 0.0009$
Try WSE = 976.6
 $Q_{0.1} = 38,500$
 $S = 0.0015$
 $S_{ave} = 0.0008$
 $h_c = 0.8$
WSE = 976.7 close enough

Calculation of Stage-Discharge Curve at Dam
 (Spillway Rating)

Assume channel slope = 0.0001 (from U.S.G.S.)

For Q = 1000 cfs

Try Ele. = 950.0

Manning: Bypass channel (n=0.035) Q = 390 cfs
 Spillway (2.5x165x1.5) Q = 550

Σ Q = 970 cfs close enough

WSE = 970.0

For Q = 5000 cfs Tailwater = 954.8 (Weir is submerged)

Try Ele = 956.0

Manning: Bypass channel (n=0.035) Q = 840 cfs
 Overbank (n=0.10) Q = 200
 Spillway (2.5x165x3.2) Q = 3205 cfs

Σ Q = 4345

Try Ele = 959.0

Bypass channel Q = 920 cfs
 Overbank Q = 350
 Spillway (2.5x165x4.2) Q = 4970

Σ Q = 6240 cfs

Interpolating, Ele for 5000 cfs = 958.3' WSE

For Q = 10,000 cfs Tailwater = 958.8'

Try Ele = 964.0

Bypass channel	Q = 1355
Overbank	Q = 1400
Spillway (3.5 x 165 x 5.2 ^{1.5})	Q = 6450
	<u>9605 cfs</u>

Try Ele = 965.0

Bypass channel	Q = 1455
Overbank	Q = 1700
Spillway (3.5 x 165 x 5.2 ^{1.5})	Q = 8915
	<u>12070 cfs</u>

Interpolating, Ele. for 10,000 cfs = 964.2'

For Q = 50,000 cfs Tailwater = 962.0

Try Ele = 978.0

Bypass channel	Q = 2920
Overbank	Q = 6700
Spillway (3.5 x 165 x 16 ^{1.5})	Q = 36960
	<u>EQ = 46580</u>

Try Ele = 979.0

Bypass channel	Q = 3050
Overbank	Q = 7200
Spillway (3.5 x 165 x 17 ^{1.5})	Q = 40480
	<u>EQ = 50,730 cfs</u>

Interpolating, Ele. for 50,000 cfs = 978.8

CAMP DRESSER & MCKEE
Environmental Engineers
Boston, Mass

CLIENT Haley and Aldrich
PROJECT EEF Dam Inspections
DETAIL Wood Pond Dam - 15722

JOB NO EA-9-R1-13 COMPUTED BY RHS
DATE CHECKED _____ DATE 7/2
CHECKED BY _____ PAGE NO 1

For $Q = 100,000 \text{ cfs}$ Tailwater = 971.2'

Try Ele = 996.0

Bypass channel $Q = 5570$
Overbank $Q = 18000$
Spillway ($3.5 \times 165 \times 24.8^{1.5}$) $Q = 71,320$

$\Sigma Q = 94890 \text{ cfs}$

Try Ele = 997.0

Bypass channel $Q = 5735$
Overbank $Q = 23000$
Spillway ($3.5 \times 165 \times 26.8^{1.5}$) $Q = 75,620$

$\Sigma Q = 104,415 \text{ cfs}$

Interpolating, Ele for $100,000 \text{ cfs} = \underline{996.5'}$

CAMP DRESSER & MCKEE
Environmental Engineers
Boston, Mass.

CLIENT Maley and Aldrich
PROJECT COE Dam Inspections
DETAILS Wood Pond Dam - Lenox

JOB NO. 501-9-94-17
DATE CHECKED _____
CHECKED BY _____

COMPUTED BY JMS
DATE 5/2/00
PAGE NO 16

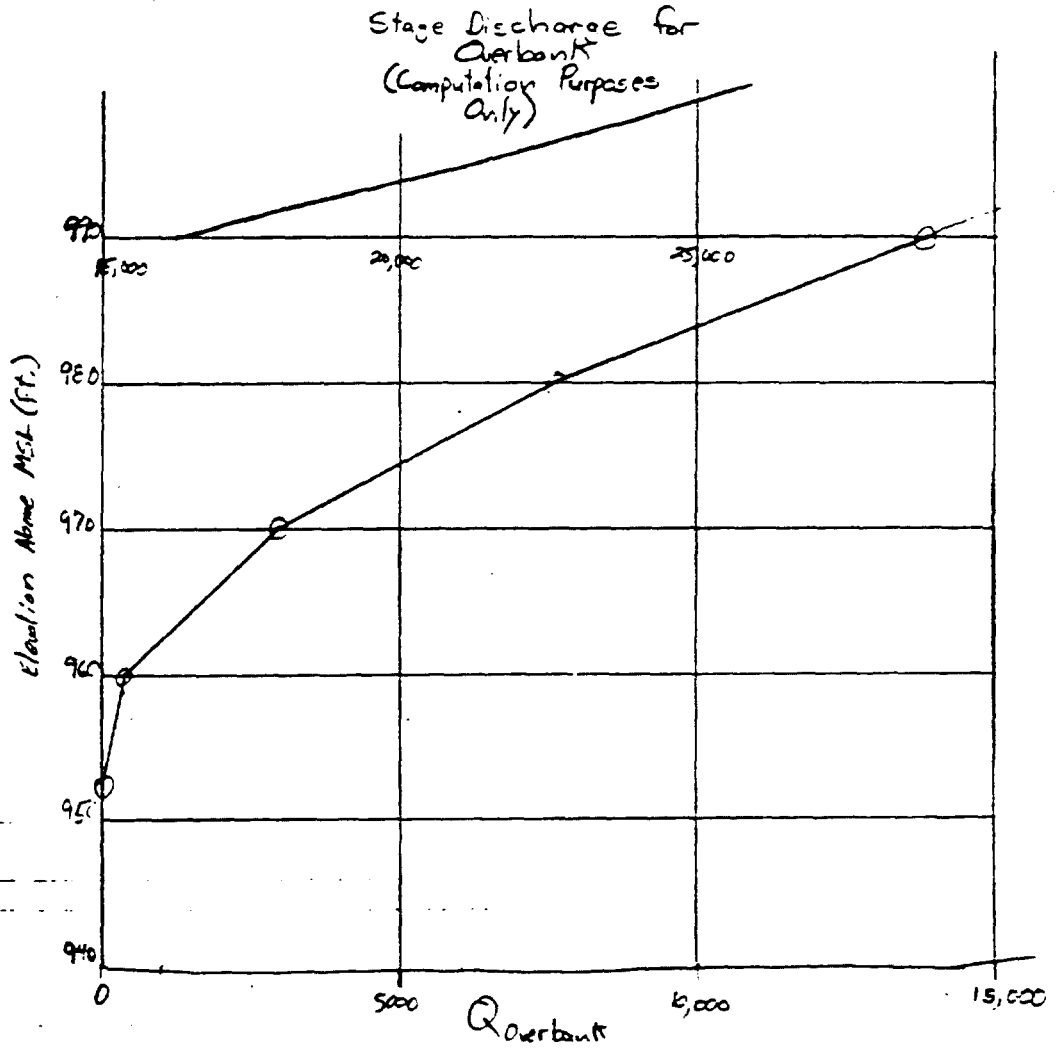

APPENDIX E - INFORMATION AS CONTAINED IN
THE NATIONAL INVENTORY OF DAMS

INVENTORY OF DAMS IN THE UNITED STATES

STATE	MA	COUNTY	FRANKLIN	CONGR DIST	1	NAME	WOODS POND DAM	LATITUDE (NORTH)	4220.9	LONGITUDE (WEST)	7314.7	REPORT DATE	DAY	MO	YR
IDENTITY NUMBER	731	INVESTOR	NEO	STATE	MA	COUNTY	FRANKLIN	CONGR DIST	1			DAY	MO	YR	

POPULAR NAME	NAME OF IMPONDMENT
VALLEY MILL DAM	WOODS POND
REGION	NEAREST DOWNSTREAM CITY - TOWN - VILLAGE
01 07	LENOX
	DIST FROM DAM (MI.)
	1
	POPULATION
	5710

TYPE OF DAM	YEAR COMPLETED	PURPOSES	HYDRAULIC CAPACITY (MGAL)	IMPOUNDING CAPACITIES (MGAL)	DIST OVN	FED H	PRV/FED	SCS A	VER/DATE
CRERTHCT	1850	UR	12	2200	550	N	N	N	N

REMARKS

22-APPROXIMATELY 23-FIRE PROTECTION

D/S	SPILLWAY	MAXIMUM DISCHARGE (CFS)	VOLUME OF DAM (CV)	POWER CAPACITY (KW)	INSTALLED	PROPOSED	NAVIGATION LOCKS	
							NO	YES
2	165 U	3460	1200					

OWNER	ENGINEERING BY
P. J. SCHWEITZER DIVISION	CONSTRUCTION BY

DESIGN	REGULATORY AGENCY
NONE	OPERATION
	MAINTENANCE
	MA DPN

INSPECTION BY	INSPECTION DATE
HALEY + ALDRICH, INC.	DAY
	MO
	YR
	30 MAY 79
	AUTHORITY FOR INSPECTION
	PUBLIC LAW 92-367

REMARKS
46-KIMBEHL-CLARK CORPORATION