

ZON MARK III *Plus*

Electronic Scare Cannon



Operating Instructions

Distributed By

Margo Supplies Ltd.

Box 5400; High River, Alberta; Canada; T1V 1M5

Phone: (403) 652-1932; Fax: (403) 652-3511

Website: www.margosupplies.com

ZON MARK III PLUS INSTALLATION AND ASSEMBLY

1. After the removal of the packing material, mount the device on the frame by means of the enclosed butterfly nuts and bolts (see diagram). Left and right base frames are identified on the center of the frame.
2. Loosen the clamping bolt (item #91116) on the outer megaphone (#91106) to free the inner megaphone (#91156). Pull the inner megaphone outwards to adjust the sound level (fully extended increases sound level). Ensure the clamping bolt is correctly secured into one of the 5 holes in the inner megaphone

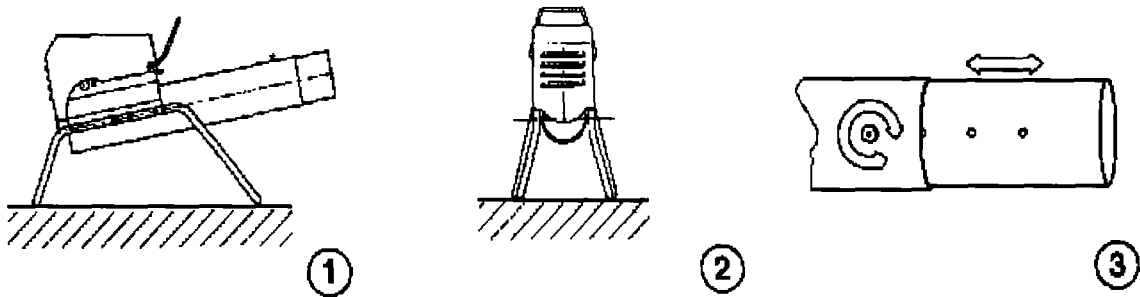

3. **WARNING:** With a functioning device:
 - Wear ear protection while operating the scare cannon or if you are within a radius of 5 meters from the device (sound pressure level is approximately 120 dB(A) FAST).
 - Never place it in a closed area.
 - Never look into the megaphone.
 - Never place objects in the megaphone.
 - Keep the gas cylinder away from sources of heat. Do not smoke.
 - The gas cylinder should be placed upright.
 - Never place the gas cylinder in a pit.
 - If there is a fire close the valve of the gas cylinder, extinguish fire with dry chemical extinguisher
 - Only propane gas should be used.
 - This device has certain components that can only be repaired or set by a recognized dealer.
4. This device runs on propane gas and uses a 12 Volt DC source (car/motorcycle/snowmobile battery).
5. Connect the gas regulator (#9023-33), equipped with a hose fracture protector (red button, #9024), to the gas cylinder. Make sure that the gas regulator and gas cylinder connections are clean. The hose fracture protector ensures that the gas cylinder will cease to emit gas if the hose would be detached for any reason or begins to leak.
6. Tighten the coupling nut on the gas cylinder (to the left) using a suitable wrench. Never use excessive force when assembling the device.

7. **Ensure that the power switch on the top of the control module (under the yellow lid of the cannon) is in the OFF position before connecting or disconnecting the battery cable.**
8. Connect the battery cable to the 12 Volt DC source (battery). Make sure that the DC source is protected against moisture (rain). Important: first connect the red battery terminal to the positive pole and then the black battery terminal to the negative pole!
9. Open the valve on the gas cylinder completely by turning it counter clockwise and push the red button on the hose fracture protector. *The hose fracture protector button must be depressed after the valve on the propane tank opened, even if the regulator has not been disconnected from the tank.* Turn the power button on, indicated by a flashing red light (LED) when on.
10. To turn off, open lid and turn the power switch off and turn the gas off.

OPERATING PROCEDURES



***IMPORTANT:** Read all operating instructions before turning on control unit. *

The control unit has two different switches:

Interval Time: This switch allows you to choose a fixed time for detonation or a random firing sequence.

Shots (On/Off): This switch allows you to choose the number of detonations in a timed cycle and is the On/Off switch for the Mark III Plus.

1. Set interval time to desired setting. When in fixed timed mode (i.e.: 1, 3, 5, 10, or 15 min.), the red LED light will flash on every 3 seconds. Detonation times are approximate in this mode. When in random mode (RAN), the cannon will detonate at random times from 1 - 17 minutes, and the red LED will flash off every 3 seconds.

2. Turn on cannon by selecting number of shots desired. In fixed time mode, shots can be set for 1, 2, or 3. In random mode, the shot selection is ignored and the number of shots will be random (the shot switch must be on 1, 2 or 3 in random mode for cannon to function).
3. **At power on and when the interval selector switch is changed to a new time setting, the cannon will fire 1 shot within 6 seconds and then go into the selected time mode.**
4. To turn cannon off, turn shot selection switch to off and close the gas valve on the gas cylinder. If you do not intend to use the cannon for a long period of time, disconnect the battery cables.

ZON MARK III PLUS RECOMMENDATIONS

Read the following information carefully. In it you will find important instructions concerning the safety and maintenance of the device. Always keep these instructions with the device.

1. Place the cannon on a stable and horizontal surface
2. Observe the local requirements and rules that may apply to noise and the production of sound in the vicinity of a residential area or otherwise.
3. Do not place any heavy objects on the scare cannon and do not block the air circulation.
4. It is important to move the device regularly in order to increase the effectiveness.
5. If the device functions inadequately, consult the failure table or your local dealer.
6. Consult your dealer for separate accessories.

ZON MARK III ROUTINE MAINTENANCE

- When not in use, store in a dry place.
- Check the following at least once per year;
 1. Check the gas hose for defects. If defects are found (porous/cracks), replace it with a new one. When in doubt, use a new hose.
 2. Check the gas regulator, fitted with a hose fracture protector, for damage or leaking. If any problems are detected, repair or replace immediately.
 3. If there are any defects in the battery cable, repair or replace it.
 4. Check the electrode (No. 91536) for damage. If any defects are detected replace with

new electrode.

5. **Check electrode and ground wire on back of barrel for corrosion or residue build-up.** Remove and clean with emery cloth. Spray a protective coating over ground wire and back of electrode to prevent corrosion. See appendix A for description.
6. Use a suitable multi-meter to check whether the DC source (battery) has enough power (minimum 10 v). If the battery requires charging, be sure to follow the manufacturers instructions carefully.
7. If other defects are detected consult your local dealer.

Parts List

Frame

91106	Outer Megaphone
91116	Clamping Bolt
91136	Rear Cover
91146	Iris Cover
91156	Inner Megaphone
91606	Cover
91616	Handle
91636	Left Base Frame
91646	Right Base Frame
91656	Cap
VM6	Butterfly Nut M6
M630ZK	Metal Screw M6x30
M610PH	Metal Screw M6x10
M6	Hexagonal Nut M6

Main Body with Control Unit

95206	Main Body
9093A	Control Unit
AK15	Battery Cable 1.5 m
91816	Clamp
LK66 mm	Hose Clamp
LK13	13 mm Hose Clamp
M610PH	Metal Screw M6 x 10
M6	Hexagonal Nut M6
7262	Bolt

Gas Valve

9043	Gas Valve Complete
7042H	Mounting Nut
9043G	Valve Only
9043H	Coil
9043J	Clamping Nut M8 x 1
V8	Washer M8

Ignition

91536	Electrode
-------	-----------

Gas regulator Complete

9023-33	Regulator Unit + HFP
9023A	Coupling Nipple (HFP)
9023B	Coupling Nut (HFP)
9023C	Connecting Piece (HFP)
9024	Hose Fracture Protector (HFP)
SL150	Hose 150 cm
91816	Clamp
91806F	Alu Ring 19 x 17 x 2 mm

ZON MARK 3

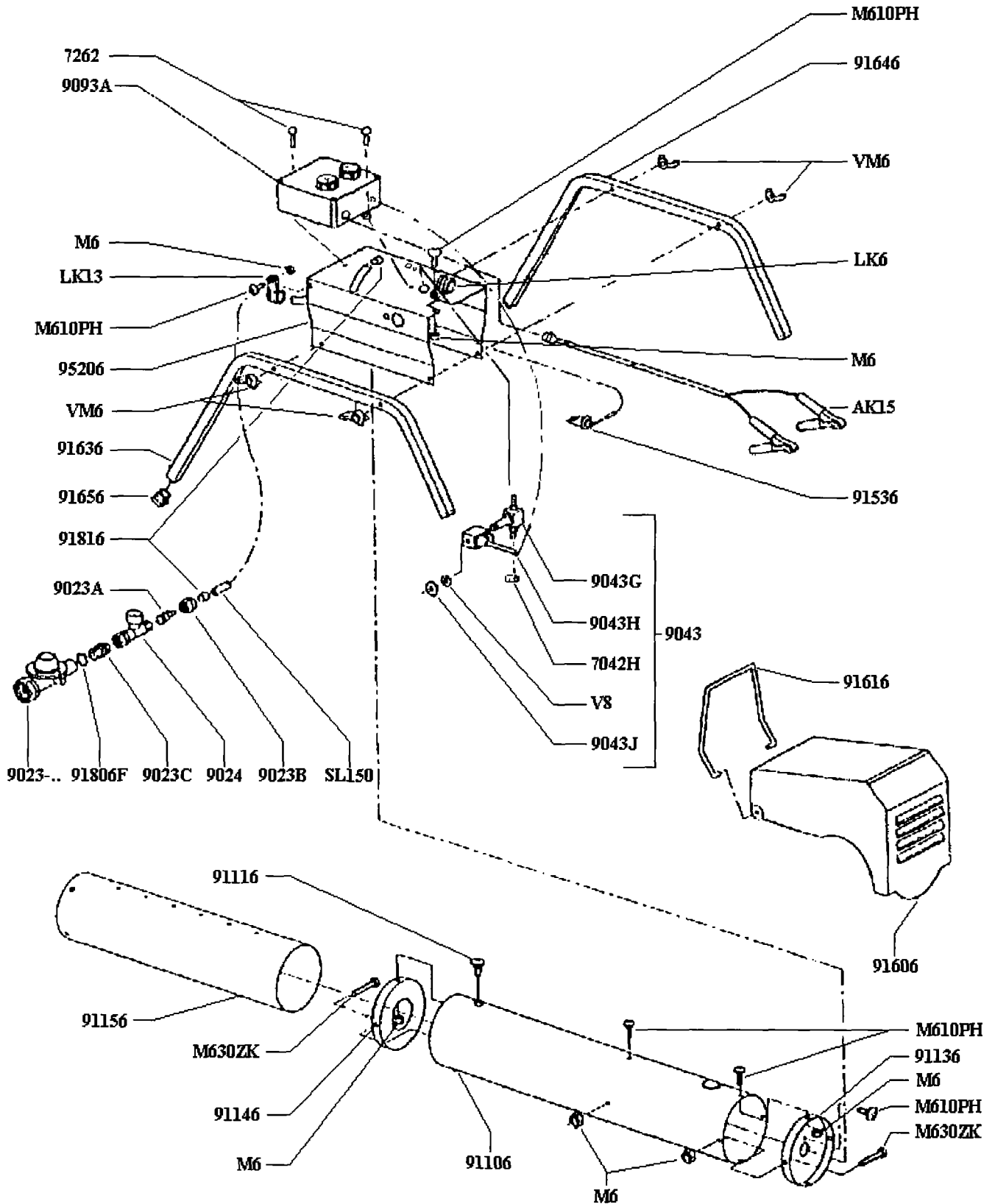

ZON MARK III PLUS TROUBLESHOOTING

FAILURE	CAUSE	REMEDY
The cannon, fully connected, fails to operate at all	<p>The control unit is turned off.</p> <p>The battery cable has not been connected properly</p> <p>Low battery</p>	<p>Turn on switch on control box.</p> <p>Ensure the battery terminals are connected properly. The black terminal is negative and the red terminal is positive.</p> <p>Recharge or connect a new battery</p>
The Zon Mark III operates, but there is no explosion or sound	<p>The gas tank valve is not open</p> <p>The gas tank is empty or does not have enough pressure</p> <p>The hose fracture protector button (red) has not been pushed</p> <p>Poor gas mixture</p> <p>Gas valve is blocked or partially blocked.</p> <p>Ignition gives a weak spark or no spark at all.</p> <p>The gas valve will not operate</p>	<p>Open the valve</p> <p>Fill or replace gas tank.</p> <p>Push the red button on the hose fracture protector one or more times.</p> <p>Gas mixture in the gas tank is not good, replace gas tank.</p> <p>Open up blockage using thin wire of approx. 0.6 mm diameter or welding tip cleaner.</p> <p>Check the electrode, No. 91536. It is possible that the porcelain base is broken: if so, replace.</p> <p>Corrosion on the connection points between the electrode and the barrel or the ground wire and the barrel. Remove electrode and ground wire and clean all contact points with emery cloth.</p> <p>Electrode No. 91536 is wet: Dry it well.</p> <p>Check the connection points. If properly connected, call the dealer for repair.</p>
The Zon Mark III works, but gives dull explosions	<p>Wind is too strong; gas to air mixture is disturbed.</p> <p>Inner megaphone not out or partially pulled out.</p> <p>Gas valve is partially blocked.</p>	<p>Place the Zon Mark III down wind or place it out of wind or behind a screen.</p> <p>Pull out to full extension.</p> <p>Open up blockage using thin wire of approx. 0.6 mm diameter or welding tip cleaner.</p>
Leaks	<p>The coupling nut on the gas regulator is not tight enough.</p> <p>The hose from the regulatory-unit to the Zon Mark III has been damaged.</p>	<p>Tighten coupling nut</p> <p>Replace the hose</p>

APPENDIX 1 – CLEANING ELECTRODE AND GROUND WIRE

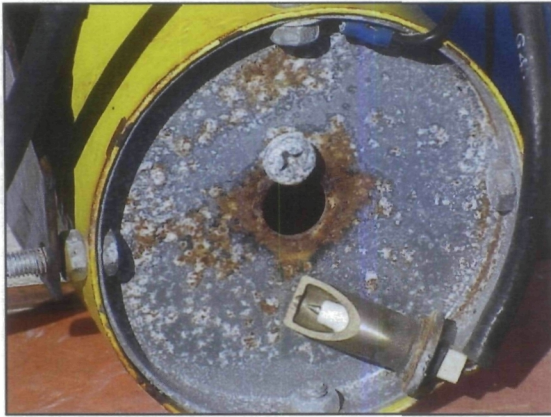

Figure 1. Corrosion of rear cover and electrode. Remove electrode from rear

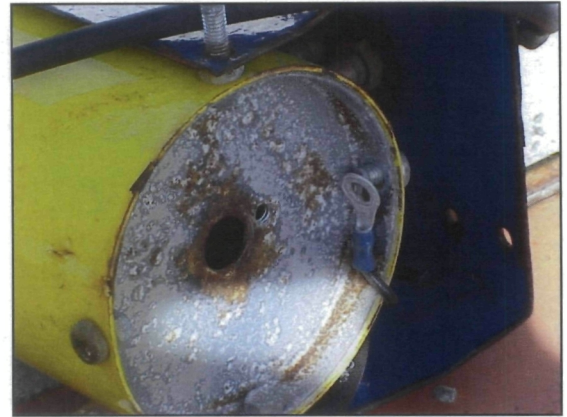

Figure 2. Corrosion of rear cover and ground wire. Remove ground wire from rear cover.

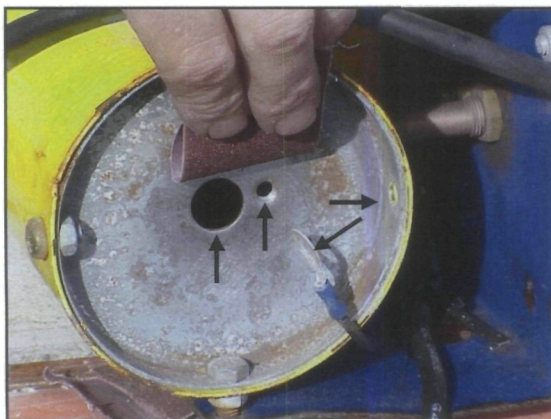

Figure 3. Cleaning points. Use emery cloth or similar material to remove any rust or corrosion from these key points.



Figure 4. Corrosion on electrode. Use a wire brush, emery cloth or similar abrasive material to remove corrosion from point where electrode contacts the rear cover.

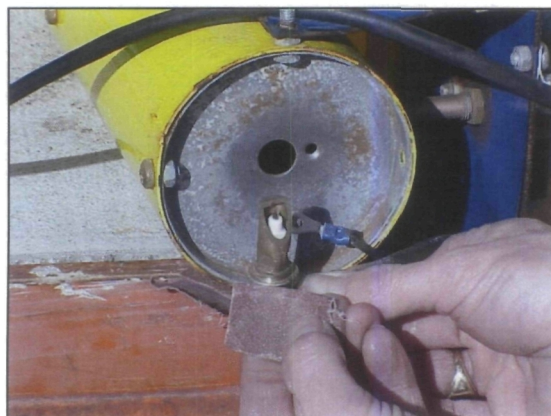

Figure 5. Clean contact points.



Figure 6. Spray back of electrode and ground wire with silicone conformal coating or similar sealant to prevent corrosion and rust.

HEAT SENSOR INSTALLATION

Please read review the entire installation before proceeding.

The heat sensor is mounted inside the barrel hidden behind the iris cover to provide protection in case of malfunction to the control unit of the cannon. It is connected on the positive lead to the control unit and will cut all power to the cannon if the heat of the sensor exceeds a critical temperature for approximately 5 seconds. The following is a guideline to replacing the sensor.

1. Disconnect the battery clips and the regulator from the propane bottle.
2. Cut the red and green wires of the sensor, leaving enough wire outside of the control box to connect the new sensor wires to. You may be able to pull some excess red and green wires out of the control box.
3. Remove the old sensor. Make note of the position of the sensor before removing it. The sensor should be in front of the iris cover (inside the barrel) above the lip of the cover (Figure 1).
4. Install new sensor. Put entire sensor into barrel (Figure 2) and bring wires up through the holes in the barrel, making sure red and green wires are on the proper sides. Ensure sensor is up above the lip of the iris cover to offer protection from the explosion.
5. Connect the red and green wires by soldering and covering with provided heat shrink or by using the marrettes.
6. Check positioning of the sensor and use cable ties on the wires to ensure the sensor does not move back down in front of the iris cover opening.

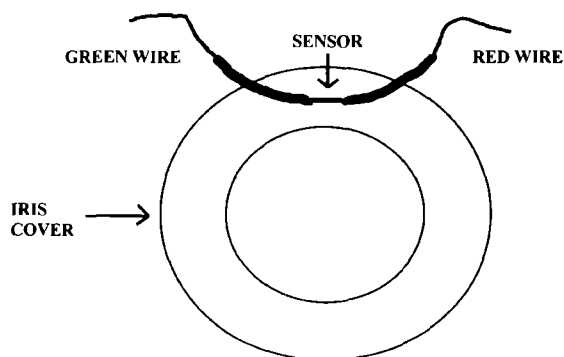

Figure 1. Front view looking in barrel at iris cover – sensor positioning

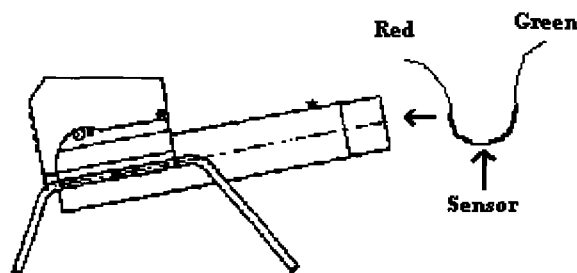
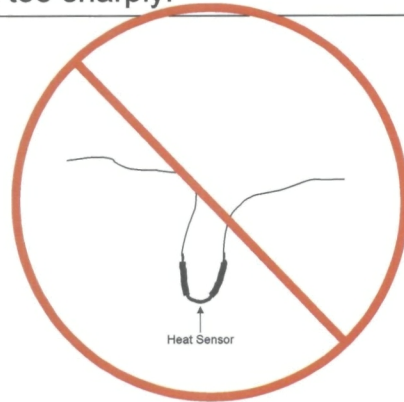
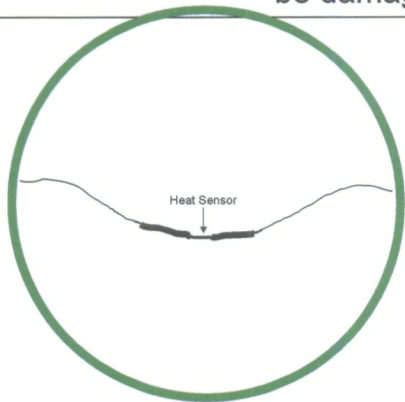

Figure 2. Inserting sensor into cannon barrel

Heat Sensor Handling Precautions

The heat sensor is delicate, when handling be sure to take care, the heat sensor can be damaged by bending it too sharply.



Heat Sensor Installation Diagram

Attach a zip tie to the red and green wires. This helps to hold the heat sensor in place, ensuring that it does not drop into the direct place of the flame produced by the explosion.

Use the supplied butt connectors to reattach the leads. Heat shrink can be used over the butt connectors to create protective a weather barrier.

