



# **BMP Structural Design Report - Northern Impoundment**

**San Jacinto River Waste Pits Site Harris  
County, Texas**

International Paper Company and McGinnes Industrial  
Maintenance Corporation

May 23, 2025

# Contents

<b>1.</b>	<b>Introduction</b>	<b>1</b>
<b>2.</b>	<b>Geotechnical Data</b>	<b>3</b>
2.1	Geotechnical Investigations	3
2.2	Subsurface Geology	3
2.2.1	Surficial Alluvium Sediments	4
2.2.2	Beaumont Clay Formation	4
2.2.3	Beaumont Sand Formation	4
2.3	Hydraulic Conditions	4
2.4	Geotechnical Design Parameters	4
2.4.1	Saturated and Buoyant Unit weights, $\gamma$	5
2.4.2	Undrained Shear Strength, $S_u$	5
2.4.3	Undrained Modulus, $E_u$ and Poisson coefficient, $\nu_u$	6
2.4.4	Drained modulus, $E'$ and Poisson Coefficient, $\nu'$	6
2.4.5	Effective Stress Parameters, $\phi'$ and $c'$	7
2.4.6	Over-Consolidation Ratio, OCR	7
2.4.7	Consolidation Parameters	7
2.4.8	Hydraulic Conductivity	8
2.4.9	Geotechnical Parameters Summary	8
<b>3.</b>	<b>Design Parameters</b>	<b>9</b>
3.1	In-Situ Soil Parameters	9
3.2	River Water Levels	9
3.3	Scour	10
3.3.1	BMP Exterior	10
3.3.2	BMP Interior	10
3.4	Wind	11
3.5	Waves	11
3.6	Barge Impact	12
3.6.1	Impact Energy	12
3.6.2	Impact Velocity	14
3.7	Earthquake	14
<b>4.</b>	<b>Load Combinations</b>	<b>15</b>
<b>5.</b>	<b>Design Criteria</b>	<b>15</b>
5.1	Failure Modes	15
5.2	Safety Factors	16
5.2.1	Embedment Depth	16
5.2.2	Sheet Pile Sections	17
5.2.3	Tie-Rod Sections	17
5.2.4	Walers	17
5.3	Deflection	18
5.4	Corrosion Protection	18

<b>6.</b>	<b>BMP Design</b>	<b>19</b>
6.1	Analysis	19
6.2	Analysis Sections	20
6.2.1	Cross-Section C1	21
6.2.2	Cross-Section C2	21
6.2.3	Cross-Sections C3 and C3A	22
6.2.4	Cross-Section C4	23
6.2.5	Cross-Section C4A	24
6.2.6	Cross-Section C5	25
6.2.7	Cross-Sections C6 and C7	25
	Alternative 1: Combination Wall with Tie-back Anchors	26
	Alternative 2: Cantilever Concrete Secant Pile	27
	Alternative 3: Concrete Secant Pile with Tieback Anchors	27
	Alternative 4: Combination Wall with Brace Piles	27
	Design System: Double Wall System	27
	Design Selection: Double Wall System	28
6.3	Structural Components	28
6.4	Scour Protection	28
6.4.1	BMP Exterior	28
6.4.2	BMP Interior	29
6.5	Wind Load Evaluation	29
6.6	Wave Load Evaluation	30
6.7	Barge Impact	30
6.7.1	Barrier Wall	30
6.7.2	BMP Impact	31
	6.7.2.1 Analysis Model	32
6.8	Pile Driveability and Vibration Analysis	33
6.9	Seepage through Sheet Piles	35
6.10	Design Summary	36
	6.10.1 Analysis Notes	37
<b>7.</b>	<b>Other Considerations</b>	<b>37</b>
7.1	Foundation Substructure of I-10 Bridge	37
7.2	Underground Utilities	37
7.3	Slope Stability	38

## Table index

Table 2.1	Unit Weights	5
Table 2.2	Undrained Elastic Modulus	6
Table 2.3	Drained Elastic Modulus	6
Table 2.4	Effective Strength Parameters	7
Table 2.5	Over-Consolidation Ratio OCR	7
Table 2.6	Consolidation Parameters	7
Table 2.7	Hydraulic Conductivity	8
Table 2.8	Geotechnical Parameters for Design	8
Table 3.1	Wave Height for Maximum Winds (1 hour) from North	11
Table 3.2	Velocity - Hydrodynamic Model	14
Table 5.1	Safety Factors for Passive Pressures - EM 1110-2-2504	16
Table 5.2	Allowable Stresses for Sheet Piles - EM 1110-2-2504	17
Table 5.3	Overstrength Factors for Tie-Rod - AISC 360	17
Table 5.4	Overstrength Factor for Walers - AISC 360	18
Table 5.5	Loss of Thickness due to Corrosion	19
Table 6.1	Barge Impact Analysis Output – Extreme Allowable Stress	33
Table 6.2	Barge Impact Analysis Output – Elastic Yield Stress	33
Table 6.3	Summary of BMP Design	37

## Figure index

Figure 1.1	Northern Impoundment BMP Alignment - Plan View	2
Figure 1.2	Typical Cross-Section of the BMP	2
Figure 2.1	Locations of Geotechnical Soundings	3
Figure 2.2	Geotechnical Information along BMP	5
Figure 3.1	Fetch Distance near Northern Impoundment	12
Figure 3.2	Navigational Waterway Northern Impoundment	13
Figure 5.1	Typical Thickness Loss - Nucor Skyline Catalog, Ports & Marine Construction	18
Figure 6.1	General Extents of the Analysis Cross-Sections	20
Figure 6.2	Analysis Cross-Section C1	21
Figure 6.3	Analysis Cross-Section C2	22
Figure 6.4	Analysis Section C3	23
Figure 6.5	Analysis Section C3A	23
Figure 6.6	Analysis Section C4	24
Figure 6.7	Analysis Section C4A	24
Figure 6.8	Analysis Section C5	25
Figure 6.9	Analysis Section C6	26
Figure 6.10	Analysis Section C7	26
Figure 6.11	FRP Barrier Wall – Alignment	31
Figure 6.12	FRP Barrier Wall – Typical Section	31
Figure 6.13	Vibration Amplitude (PPV) for Pile Installation Equipment	35
Figure 6.14	Discharge - Pressure Drop Relationship, Arcelor Mittal	36

# Attachments

Attachment 1	Geotechnical Parameters and Data Profiles
Attachment 2	BMP Analysis - PLAXIS Sections
Attachment 3	Structural Calculations
	3.1 BMP Design Calculations
	3.2 Exterior Scour Protection
	3.3 Interior Scour Protection
	3.4 Wind Load Evaluation
	3.5 Sheet Pile Seepage Evaluation
	3.6 Barge Impact Evaluation
	3.7 WEAP Output
	3.8 Velocity Buoy Data Processing
	3.9 Wind and Wave Evaluation
Attachment 4	Slope Stability - Excavation

# 1. Introduction

This Best Management Practice (BMP) Design Structural Report (Report) was prepared by GHD Services Inc. (GHD), on behalf of International Paper Company (IPC) and McGinnes Industrial Maintenance Corporation (MIMC; collectively referred to as the Respondents) for the Northern Impoundment of the San Jacinto River Waste Pits Superfund Site in Harris County, Texas (Site). The Northern Impoundment is located immediately north of the Interstate Highway-10 (I-10) Bridge over the San Jacinto River. The remedial activities described in the 2017 United States Environmental Protection Agency (EPA) Record of Decision (ROD) require the removal of the waste material within the Northern Impoundment, much of which is submerged in the river. The excavation depths to remove the waste material extend, in some locations, tens of feet (ft) below the riverbed. As part of the Third Final 100% Remedial Design - Northern Impoundment (Third Final 100% RD), the Respondents have proposed to construct an engineered barrier or cofferdam (best management practice [BMP] wall) encircling the Northern Impoundment to divert water around the Northern Impoundment and allow excavation of the waste material in the dry. This Report summarizes the design criteria, geotechnical parameters, structural analysis and calculations, and various other considerations involved in the design of the BMP wall.

The BMP is proposed to consist of a double sheet pile wall approximately 3,340 ft in length (i.e., two parallel sheet pile walls connected with tie-rod anchors and filled with a fill material). The proposed alignment presented in the Third Final 100% RD locates the BMP a minimum of 30 ft away from the horizontal excavation extent on all sides of the impoundment with the exception of locations along the southern extent, in which the minimum offset is slightly less than 30 ft in some places, as shown on Figure 1-1.

For purposes of the BMP wall's design, the existing riverbed between the BMP (interior wall) and the excavation area is referred to as a "Soil Buttress." The width of the Soil Buttress (30 ft in most locations) will be maintained during excavation activities and allows the BMP to remain structurally sound while conducting the excavation activities. In some instances, additional fill material is added to the Soil Buttress to raise the interior riverbed elevation and reduce the exposed height of the BMP above riverbed elevation. That additional fill is referred to as a "Raised Bench." A riprap apron is installed on the exterior and interior side of the BMP to protect the riverbed from potential scour due to change in flow dynamics and overtopping during a flooding event, respectively. A sacrificial barrier wall comprising of fiberglass reinforced polymer (FRP) composite piles and walers will be installed approximately 20 ft from the exterior wall of the BMP to protect specific portions of the BMP from barge impacts.

The BMP will be a temporary structure, expected to remain in place for the length of the remedial action (RA), currently estimated at approximately seven years. A typical cross-section of the BMP is shown on Figure 1-2.

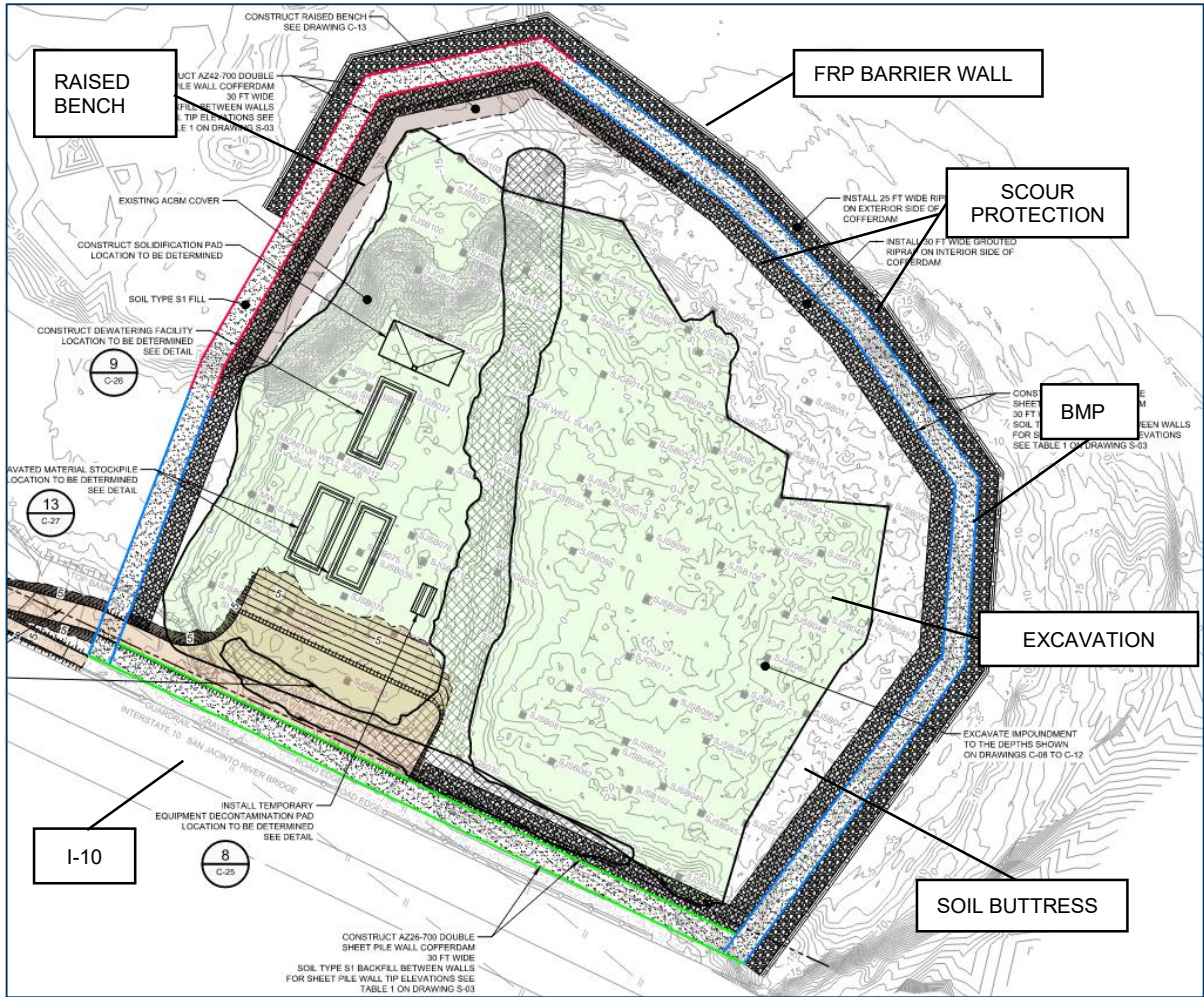

Figure 1.1 Northern Impoundment BMP Alignment - Plan View

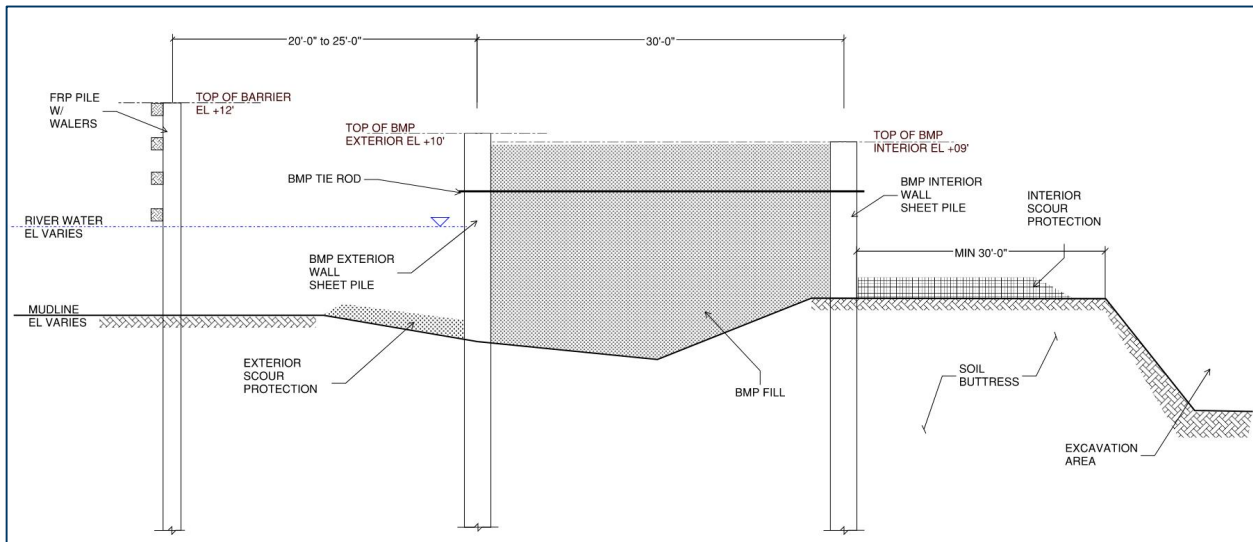

Figure 1.2 Typical Cross-Section of the BMP

## 2. Geotechnical Data

### 2.1 Geotechnical Investigations

In order to define the geotechnical conditions of the Northern Impoundment, four geotechnical investigations were conducted as listed below:

- Remediation investigation (RI) in 2011.
- First Phase Pre-Design Investigation (PDI-1) in 2018.
- Second Phase Pre-Design Investigation (PDI-2) in 2019.
- Supplemental Design Investigation in 2021.

The Geotechnical Engineering Report (Appendix B) includes additional details, field logs, laboratory results, and a summary of these investigations. During these four investigations, a total of 43 geotechnical boreholes were drilled. During the recent SDI, two piezometers were installed, and cone penetration tests (CPT) were also performed at 13 locations on or close to the alignment of the proposed BMP. Figure 2-1 shows the locations of the geotechnical soundings.



Figure 2.1 Locations of Geotechnical Soundings

### 2.2 Subsurface Geology

The geology in the vicinity of the Northern Impoundment is highly heterogeneous and a thorough understanding of that geology is critical for the design of the BMP. A detailed description of the Northern Impoundment geology is provided

in the Geotechnical Engineering Report (Appendix B). The approximate subsurface stratigraphy within the Northern Impoundment, as determined from the various geotechnical investigations, is comprised of the following three layers.

### 2.2.1 Surficial Alluvium Sediments

The Surficial Alluvium Sediments are fairly heterogenous, consisting of silty sands, sands silts, lean clays, and sandy clays. The cohesive sediments are typically very soft to firm and the cohesionless granular sediments are loose-to-compact. The thickness of the sediments ranges between 10 to 30 ft.

### 2.2.2 Beaumont Clay Formation

The Beaumont Clay Formation was generally encountered starting at elevations ranging between -20 ft to -35 ft North American Vertical Datum of 1988 (NAVD88). This formation is composed of a stiff-to-very-stiff high plasticity clay (fat clay) and interspersed with seams or lenses of sandy materials. The formation extended to approximate elevations of -80 ft NAVD88 on the western side and -65 ft NAVD88 on the eastern side of the Northern Impoundment.

### 2.2.3 Beaumont Sand Formation

The Beaumont Sand Formation was generally encountered at elevations ranging between -50 ft to -70 ft NAVD88. This formation is essentially composed of compact-to-dense silty sand to clayey sand.

## 2.3 Hydraulic Conditions

During the SDI in 2021, piezometers were installed in borings SJMW-16 and SJMW-17 and the water levels were logged in these piezometers at regular time intervals. The monitored data show that the water level in the river fluctuates with the tides between elevations 0 to 3 ft NAVD88 (with an average of 1.5 ft) while the piezometric level in the Beaumont Sand fluctuates between elevations -4 to -2 ft NAVD88 (with an average value of approximately -2.5 ft).

## 2.4 Geotechnical Design Parameters

Figure 2-2 shows the available data from various geotechnical investigations for the Northern Impoundment along the BMP alignment. The following sections outline the various geotechnical parameters used for the analysis of the BMP.



Figure 2.2 Geotechnical Information along BMP

### 2.4.1 Saturated and Buoyant Unit weights, $\gamma$

The total unit weight,  $\gamma_s$  was estimated based on the water content values considering a specific density, G of 2.7. The variation of  $\gamma_s$  with elevation for the alluvium sediment, Beaumont Clay and Beaumont Sand is shown in Enclosure 1.A of Attachment 1.

Table 2-1 presents the saturated and buoyant unit weights considered in the analysis.

Table 2.1 Unit Weights

Saturated Unit weight (Buoyant Unit Weight), lb/ft <sup>3</sup>			
Alluvions Sediments	Beaumont Clay	Beaumont Sand	Fill
118 (55.6)	125 (62.6)	130 (67.5)	130 (68)

### 2.4.2 Undrained Shear Strength, $S_u$

The undrained shear strength ( $S_u$ ) profiles based on the vane test measurements and CPT soundings are shown in Attachment 1.

1. Alluvium Sediments: Enclosure 2.A
2. Beaumont Clay: Enclosure 2.B.

### 2.4.3 Undrained Modulus, $E_u$ and Poisson coefficient, $\nu_u$

The undrained elastic modulus  $E_u$  was estimated based on correlations with the undrained shear strength  $S_u$ . The  $E_u$  profiles shown in Attachment 1 for the Alluvium Sediments and Beaumont Clay layer (Enclosures 3.A and 3.B) were defined using Equations 2-1 and 2-2, below.

Alluvium Sediments:  $E_u = 400 \cdot S_u$  [2-1]

3. Beaumont Clay:  $E_u = 300 \cdot S_u$  [2-2]

Table 2-2 presents the  $E_u$  values considered in the analysis.

**Table 2.2 Undrained Elastic Modulus**

Undrained Elastic Modulus $E_u$ , tsf			
Alluvium Sediments	Beaumont Clay	Beaumont Sand	Fill
50 (Enclosure 3.A)	400 (for the first 10 ft following the Alluvium/Clay interface) 500 (for the remaining clay thickness) (Enclosure 3.B)	N/A	N/A

Undrained Poisson Coefficient  $\nu_u = 0.5$  is considered in the design (corresponding to the theoretical value).

### 2.4.4 Drained modulus, $E'$ and Poisson Coefficient, $\nu'$

For the cohesive deposits (Alluvium Sediments and Beaumont Clay), the drained elastic modulus  $E'$  was evaluated from the undrained modulus (see Table 2-3) using the following theoretical equation:

$$E' = E_u \cdot (1 + \nu') / 1.5 \quad [2-3]$$

Assuming  $\nu'$  (drained Poisson coefficient) value of 0.3, equation 2-3 becomes:

$$E' = 0.87 E_u$$

For cohesionless soils (Beaumont sand and cohesionless layers of the Alluvium Sediments), the drained elastic modulus was estimated using equation 2-4 based on correlations using the CPT results.

$$E' = 0.015 \cdot 10^{0.55Ic + 1.68} \cdot (q_t - \sigma_{vo}) \quad [2-4]$$

Where:

- $q_t$  is the tip resistance.
- $\sigma_{vo}$  is the total vertical stress.
- $Ic$  is the CPT behavior index.

Table 2-3 presents  $E'$  values considered in the analysis.

**Table 2.3 Drained Elastic Modulus**

Drained Elastic Modulus $E'$ , tsf			
Alluvium Sediments	Beaumont Clay	Beaumont Sand	Fill
43.5	$0.87 \cdot E_u^1$	1040 (See Enclosure 3.C)	150

Notes:

<sup>1</sup> Refer to Section 2.4.3 for values of  $E_u$

Drained Poisson Coefficient  $\nu' = 0.3$  is considered in the design.

## 2.4.5 Effective Stress Parameters, $\phi'$ and $c'$

The friction angle  $\phi'$  and the effective cohesion  $c'$  for both the cohesive Alluvium Sediments and the Beaumont Clay were defined based on a limited number of triaxial tests results.

The friction angle  $\phi'$  for the cohesionless alluvium sediments and Beaumont Sand was defined from CPT results correlation presented in the literature - equation 7-5. Enclosures 4.A and 4.C in Attachment 1 show  $\phi'$  profiles as defined from this equation for cohesionless alluvium sediments and Beaumont sand, respectively.

$$\phi' = 17.6 + 11. \log ((q_t - \sigma - \sigma_{vo}) / \sigma') / \sigma'_{vo} \quad [2-5]$$

The effective strength parameters used in the design are presented in Table 2.4.

**Table 2.4** *Effective Strength Parameters*

Alluvium Sediments		Beaumont Clay		Beaumont Sand		Fill	
$\phi'$ , degree	$c'$ , psf	$\phi'$ , degree	$c'$ , psf	$\phi'$ , degree	$c'$ , psf	$\phi'$ , degree	$c'$ , psf
26 (See Enclosure 4.A)	42	28 (See Enclosure 4.B)	150	37 (See Enclosure 4.C)	0	32	0

## 2.4.6 Over-Consolidation Ratio, OCR

The over-consolidation ratio ( $OCR = \sigma'_p / \sigma'_{vo}$ ) values were defined from correlations-based CPT results (using Equation 2-6). The estimated OCR value profiles are shown in Enclosure 5.A of Attachment 1.

$$OCR = 0.33. (q_t - \sigma_{vo}) \quad [2-6]$$

Where:

- $q_t$  is the tip resistance.
- $\sigma_{vo}$  is the total vertical stress.

The OCR values used for the design are presented in Table 2-5.

**Table 2.5** *Over-Consolidation Ratio OCR*

OCR			
Alluvium Sediments	Beaumont Clay	Beaumont Sand	Fill
1.0	10 to 2 See Enclosure 5.A	N/A	N/A

## 2.4.7 Consolidation Parameters

The consolidation parameters based on consolidation tests are listed in Table 2-6.

**Table 2.6** *Consolidation Parameters*

Parameters	Alluvium Sediments	Beaumont Clay	Beaumont Sand	Fill
Recompression, $c_r$	0.04	0.02	N/A	N/A
Compression Index, $cc$	0.32	0.25		
Initial Void Ratio, $e_o$	0.95	0.68		
Pre-Consolidation pressure, $\sigma\sigma'_p$	$= \sigma'_{vo}$	Varies with OCR (See Enclosure 5.A)		

## 2.4.8 Hydraulic Conductivity

The hydraulic conductivity  $k$  profiles were derived from the CPT results and hydraulic conductivity tests (Enclosure 6.A of Attachment 1). The  $k$  values considered for the design are summarized below in Table 2-7.

For the sediments eight (8) lab tests were done for RI2020 in addition to the 3 ones already considered in the initial Enclosure 6.A. The results show the  $k$  values from the CPT are in the range of the lab values. The average value is about  $4 \times 10^{-3}$  ft/day.

For the clay, three (3) lab test was done in RI2020. The  $k$  lab values show a large scatter (about 2 order of magnitude).

The correlation providing the hydraulic conductivity value based on the CPT results is:

$$k = 10^{(0.952 - 3.04 I_c)} \text{ m/s, where } 1.00 < I_c \leq 3.27$$

$$k = 10^{(-4.52 - 1.37 I_c)} \text{ m/s, where } 3.27 < I_c \leq 4.00$$

$I_c$  is a function of the parameters  $q_t$  and  $f_s$  measured in a CPT sounding.

Table 2.7 Hydraulic Conductivity

Hydraulic Conductivity, ft/day			
Alluvium Sediments	Beaumont Clay	Beaumont Sand	Fill
0.3 to $3.0 \times 10^{-4}$	$10^{-2}$ to $10^{-4}$	2.5	3

## 2.4.9 Geotechnical Parameters Summary

A summary of the geotechnical parameters used in the design are provided in Table 2-8.

Table 2.8 Geotechnical Parameters for Design

Definition	Unit	Alluvium Sediments	Beaumont Clay	Beaumont Sand	Fill
Unit weight (saturated), $\gamma$	lb/ft <sup>3</sup>	118	125	130	130
Undrained Young Modulus, $E_u$	tsf	50 Enclosure 3.A	400 to 500 Enclosure 3.B	-	-
Drained Modulus, $E'$	tsf	43.5	0.87. $E_u$	1040	150
Undrained Poisson Coefficient, $\nu_u$	-	0.5	0.5	-	-
Drained Poisson coefficient, $\nu'$	-	0.3	0.3	0.3	0.3
Friction Angle, $\phi'$	Degree	26	28	37	30
Effective Cohesion, $c'$	psf	42	150	0	0
Undrained Shear Strength, $S_u$	tsf	Enclosures 2.A	Enclosure 2.B	-	-
Over-Consolidation Ratio, OCR	-	1	10 to 2	-	-
Hydraulic Conductivity, $k$	ft/day	$1.1 \times 10^{-3}$	$8.6 \times 10^{-3}$	0.9	3
Recompression Index, $cc_r$	-	0.03	0.03	-	-
Compression Index, $cc_c$	-	0.32	0.29	-	-
Initial void ratio, $e_o$	-	0.95	0.68	-	-
$cc/(1+e_o)$	-	0.16	0.15	-	-

## 3. Design Parameters

The following guidelines and standards are the ones that were primarily used to develop the design of the BMP:

- American Society of Civil Engineers (ASCE) 7-16, Minimum Design Loads and Associated Criteria for Building and Other Structures.
- Engineering Manual (EM) 1110-2-2504, Design of Sheet Pile Walls by United States Army Corps of Engineers (USACE).
- American Institute of Steel Contractors (AISC) 360-16, Steel Construction Manual 15<sup>th</sup> Edition.
- USACE Hurricane and Storm Damage Risk Reduction System Design Guidelines, updated June 2012.
- American Association of State Highway and Transportation Officials (AASHTO) LRFD Bridge Design Specifications, 2012.
- Nucor Skyline Technical Product Manual, 2021 Edition.
- Arcelor Mittal Impervious Steel Sheet Pile Walls Design & Practical Approach.

ASCE 7-16 categorizes structures into four Risk Categories (I through IV). During time periods when excavation is taking place, the BMP may be considered similar to structures or facilities that process, handle, or store toxic substances. ASCE 7-16 categorizes such structures or facilities as being in Risk Category IV, in which the failure of such structures or facilities may pose a significant hazard to the public.

USACE EM 1110-2-2504 defines the following load case conditions based on severity and probability of occurrences during the design life of the structure:

- **Usual:** Service level loading experienced frequently such as static earth pressure, hydrostatic pressures after installation of the BMP and during excavation with normal water levels in the river.
- **Unusual:** Loads larger than those considered usual and experienced less frequently such as 100-year probability storm events and high water levels in the river.
- **Extreme:** Worst-case scenario loads, rarely experienced during the design life of the structure, such as hurricane level winds, flood levels in the river and barge impacts.

*Note: All elevations in the calculation are noted with respect to the NAVD88 datum.*

### 3.1 In-Situ Soil Parameters

The soil parameters evaluated for the design and analysis of the BMP are discussed in Section 2.4. The subsurface soils include fine grained material that is expected to behave differently in drained (long-term) and undrained (short-term) condition. Both drained and undrained behaviors were analyzed.

### 3.2 River Water Levels

The loading from the river water with a density of 62.4 lb/ft<sup>3</sup> was applied as hydrostatic pressure.

The river water is influenced by the tidal waters from the bay and Gulf of Mexico. The water density will be in the range of 62.4 lb/ft<sup>3</sup> (freshwater) to 64 lb/ft<sup>3</sup>(seawater). The maximum difference of 1.6 lb/ft<sup>3</sup> (2.5%) will not have any impact on the design.

Tide data is available from the NOAA<sup>1</sup> Station 8770613 located approximately 9 miles south of the Northern Impoundment. The mean higher high water (MHHW) elevation is 1.33 ft with respect to the mean lower low water (MLLW). The daily tide variation is significantly lower than the water levels assumed for the design of the BMP. Hence, tides will not govern the design.

---

<sup>1</sup> National Oceanic and Atmospheric Administration Station at Morgans Point, Barbours Cut, Texas.

The different water elevations corresponding to various load case conditions are as follows:

- **Usual** +5 ft NAVD88
- **Unusual** +10 ft NAVD88
- **Extreme** +10 ft NAVD88 (used for Barge Impact loading condition)

## 3.3 Scour

### 3.3.1 BMP Exterior

The presence of the BMP can affect the natural flow state of the San Jacinto River in the vicinity of the Northern Impoundment. The scour potential of the river flow around the BMP installation was evaluated using the Hydrodynamic Model developed for the Northern Impoundment. The shear stresses determine the capability of the river flow to move the riverbed material (sediment). The analysis method and results are provided in Appendix F.

The model evaluated the changes in water circulation with and without the BMP installation for 2-year, 10-year, 100-year and 500-year flow event in the river. The analysis results show that average flow velocity increases as the river discharge increases, and it decreases with the increase in water surface elevation.

With the measured average sediment size, it is noted that shear stress exceeding 0.15 Pascals (Pa) has the potential to mobilize the sediment in the vicinity of the Northern Impoundment. The analysis results show maximum increase in shear stress of 2.65 Pa, maximum value of shear stress of 4.34 Pa and an average value of 0.24 Pa. The shear stress values are large compared to the critical shear stress value of 0.15 Pa for the sediment in the area, indicating that the soil particles are mobile and there is potential for scour and/or sediment deposition along the outside perimeter of the BMP.

The maximum shear stresses differences were observed in two locations – the southwest corner and the north side of the BMP installation. The elevated shear stresses are due to the increase in the river flow within these areas due to the presence of the BMP. However, the bathymetry in the model does not account for modifications of the access road for purposes of the RA which will elevate the area in the southwest corner, limiting the river flow and in effect, preventing increase in the shear stress reflected in the analysis model.

The relatively small value of the maximum shear stress indicates that, except for the two locations discussed above, the conditions overall remain similar to the existing conditions (without the BMP in place). The pattern is similar for all the four modelled storm conditions (2-year, 10-year, 100-year and 500-year flow events) with only small differences in magnitude.

Scour protection measures such as rock or riprap will be required around the majority of the perimeter of the wall (see Figure 1-1).

### 3.3.2 BMP Interior

Based on the evaluation of the historic data for the water levels and hindcast model (Third Final 100% RD), there have been five (5) instances of water level exceeding elevation +10 ft that occurred outside the planned excavation season. The BMP is designed for water levels ranging from normal levels (elevation +2 ft) to top of the exterior wall (elevation +10 ft).

For the rare instances where the water level exceeds elevation +10 ft, the plunging water may cause scour at the interior base of the BMP wall. The riverbed elevation within the Northern Impoundment varies between 0 to -5 ft on the interior of the BMP walls, except in the northwest corner where the riverbed elevation is approximately -15 ft. The riverbed elevation will be raised to elevation -4 ft along the northwest corner by installing a 30 ft wide bench.

Based on the calculated flow rate over the height of the BMP, the entire BMP will fill to top of the wall within 1 to 2 hours when the river level rises only 6 inches above the top of the BMP wall. The water levels in the river may continue to rise for several hours but as the Northern Impoundment starts filling with water, the energy of the water

overtopping the structure will be dissipated before it reaches the base of the BMP wall and the potential for scour will be reduced.

Scour protection measures such as rock or riprap will be provided along the entire interior perimeter of the walls for the initial stages of river water overtopping the BMP wall, should this occur.

### 3.4 Wind

The 3-second gust design wind speeds and hurricane exposure are defined in ASCE 7-16 Chapter 26. The web-based hazard tool by ASCE (<https://asce7hazardtool.online>) provides site-specific information. The standard design wind speeds relate to a maximum recurrence interval (MRI) of 100years. The wind speeds for Risk Category IV structure in hurricane exposure areas correspond to MRI of 3000years. All wind speeds are defined at 33ft above ground level.

- Design wind velocity, 3-second gust, MRI 10-years,  $V_{10} = 77$  mph.
- Design wind velocity, 3-second gust, MRI 100-years,  $V_{100} = 116$  mph.
- Design wind velocity, 3-second gust, MRI 3000-years,  $V_{3000} = 154$  mph.
- Exposure Category C.
- Wind directionality,  $K_d = 0.85$  (solid freestanding wall).
- Topographic Factor,  $K_{zt} = 1.0$ .
- Ground Elevation Factor,  $K_e = 1.0$ .
- Velocity Pressure Exposure Coefficient,  $K_z = 0.85$ .

$$\text{Velocity Pressure, } q_z = 0.00256 K_z K_{zt} K_d K_e V^2$$

$$\text{Using } V = V_{100}, q_{z100} = 24.89 \text{ lb/ft}^2 \text{ (Unusual load condition).}$$

$$\text{Using } V = V_{3000}, q_{z3000} = 43.87 \text{ lb/ft}^2 \text{ (Extreme load condition).}$$

### 3.5 Waves

Wind-waves are generated by sustained winds over unobstructed open waters (fetch). The Northern Impoundment is sheltered by land on all sides within 0.2 miles except the north and northwest directions as shown in Figure 3.1. There are barges moored on the north side within 0.3 miles interrupting the open waters and beyond that, the nearest land is 0.5 miles away. The fetch distance perpendicular to the northwest is less than 1.5 mile.

Table 3.1 provides the maximum wave height developed from sustained winds over the maximum fetch distance. The detailed evaluation of wind speed, wind direction, and water levels to calculate the waves near the Northern Impoundment is provided in Attachment 3.

Table 3.1 Wave Height for Maximum Winds (1 hour) from North

Water Level (ft NAVD88)	Average Water Depth (ft)	Wind Wave Height (ft)	Peak Period (s)	Effective Water Surface Elevation (ft NAVD88)
2	10	0.85	2.63	2.85
3	11	0.85	2.64	3.85
4	12	0.85	2.65	4.85
5	13	0.86	2.65	5.85

Since the BMP is designed for water surface elevation at top of the wall (elevation +10 ft), the wind-waves will not govern the BMP design over the loading scenarios with the total hydrostatic pressure applied from top of the wall and barge impact as described in Section 3.6.

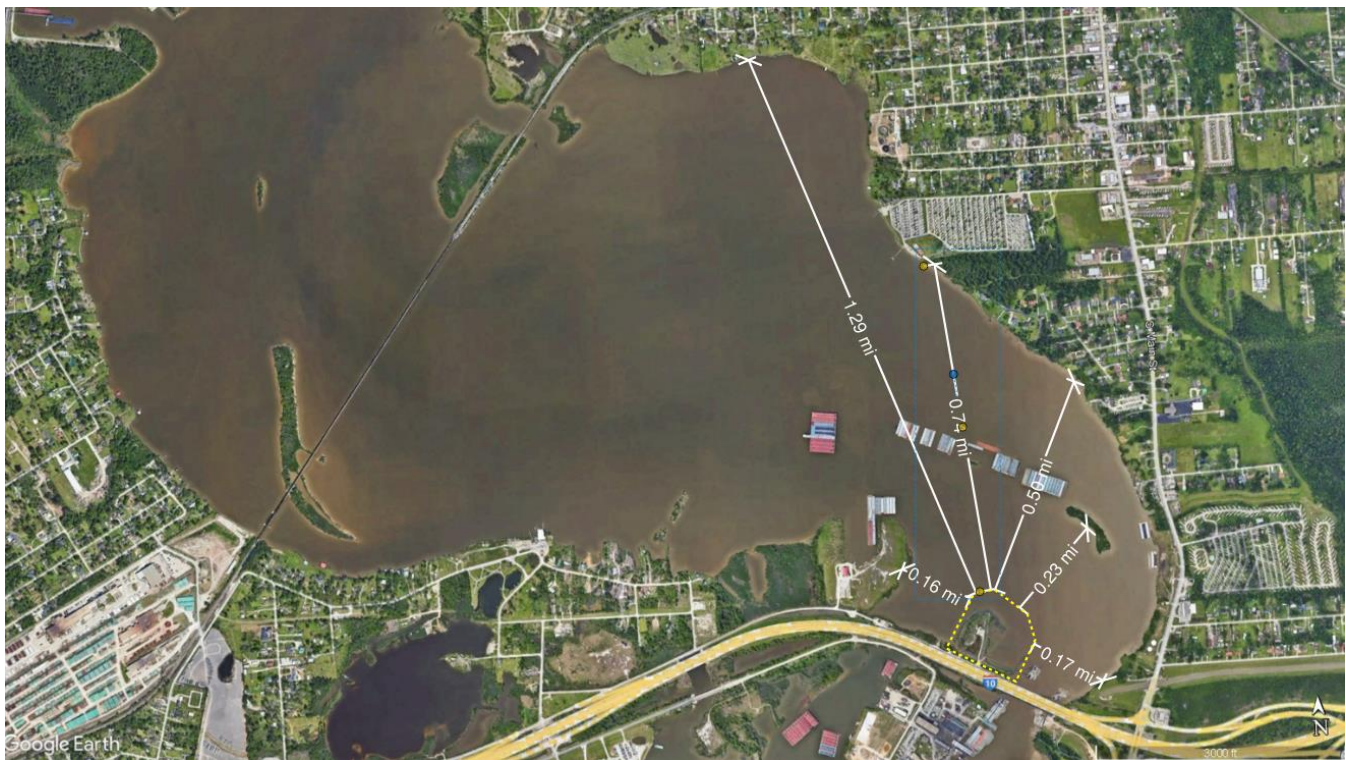

Figure 3.1 Fetch Distance near Northern Impoundment

Wake-waves are generated by passing vessels in the area and approach the BMP walls at an angle as the navigation channel flows parallel to the walls. Similar to the wind-waves, wake-waves should also be combined with the normal water levels in the area (elevation +2 ft to +5 ft). Wind-waves are not combined with wake-waves since passing vessels overlapping with a storm event is unlikely. Since the BMP will be designed for water surface elevation at top of the wall (elevation +10 ft), the wake-waves will not govern the BMP design over the loading scenarios with the total hydrostatic pressure applied from top of the wall and barge impact as described in Section 3.6.

## 3.6 Barge Impact

Given the heavy barge traffic in the San Jacinto River, there is a potential for the BMP to be struck by a barge. An impact could be the result of a barge coming off its mooring and drifting toward the BMP during a storm or it could be the result of a towed barge veering off course. The segment of the river around the BMP actively used by barges is shown in Figure 3-1. The barges traveling in the navigational waterway, either empty or loaded, would be likely to make contact with the BMP at an angle. The barges moored directly north of the BMP would be likely to make head-on contact with the BMP. The impact energy from a barge moving at the river flow velocity will be absorbed by the combination of a barrier wall system installed outboard of the BMP and the BMP structure.

### 3.6.1 Impact Energy

The kinetic energy from impact can be determined as follows, where velocity may be either the flow velocity or the navigation speed. The energy of impact will be lower for any impact angle other than head-on collision.

$$\text{Kinetic Energy of Impact} = 0.5 \times \text{Mass} \times (\text{Velocity} \times \cos(\alpha))^2$$

Where:

Mass = Mass of the vessel

Velocity = Speed of the vessel at impact

cosine ( $\alpha$ ) = directional factor for impact angle relative to the velocity vector.

= 1 for Head-on impact, i.e., 0 degrees relative to velocity vector.

The kinetic energy will be absorbed by the structures (barrier wall and BMP) but the barge itself will absorb some energy and suffer damage. The American Association of State Highway Transportation Officials (AASHTO)<sup>2</sup> method to determine impact force absorbed by bridge piers was used for evaluating the BMP. This method is conservative since the BMP will have a larger profile area than the typical bridge piers to absorb impact and distribute the energy.



Figure 3.2 Navigational Waterway Northern Impoundment

The USACE has developed design guidelines outlining minimum impact forces for hurricane protection structures in the New Orleans area.<sup>3</sup> These include structures in protected waterways not exposed to tidal surge (Zone 1A). The conditions at the Northern Impoundment are similar. The extreme load condition criterion for Zone 1A corresponds to an impact force of 400 kips from a light barge applied at the top of the wall with hydrostatic pressure induced by the 100-year still water level and wind load applied on any exposed portion of the wall. It should be noted that heavier vessels did not govern the design as the velocities of these vessels were considerably less.

<sup>2</sup> AASHTO LRFD Bridge Design Specifications, Section 3.14

<sup>3</sup> USACE Hurricane and Storm Damage Risk Reduction System Design Guidelines, Section 5.2.1.

AASHTO requires all bridge piers located in navigable waterway crossings to be designed for ship and barge impact. The required minimum impact load corresponds to a 195-ft long, 35-ft wide, and 12-ft tall empty hopper barge (displacement = 200-ton), drifting toward the structure. This barge size is representative of the barges in the area.

The Texas Department of Transportation (TxDOT)'s design criteria for the dolphin and fender system protecting the I-10 Bridge piers includes impact from a 30,000-barrel (BBL) barge, one of the larger barges in the area. A typical 30,000 BBL barge is 300-ft long, 54-ft wide, and 12-ft tall. In laden condition, the barge is loaded to full capacity and displaces 30,000 BBL equivalent or approximately 168,500 ft<sup>3</sup> of water. Thus, the barge weighs approximately 5,250 US-tons or 10,500 kips in laden condition. In ballasted condition, the barge carries only fuel and ballast water and weighs approximately 910 US-tons or 1,820 kips.

The head-on impact from the 54 ft wide, 30,000 BBL barge resulted in impact energy (and force) greater than the values recommended using USACE and AASHTO vessels. Therefore, the 54-ft, 30,000 BBL barge is considered the design barge for evaluating impact. A contact width of 50-ft was assumed to account for variations in the barge bow shapes.

### 3.6.2 Impact Velocity

The hydrodynamic model (Appendix F) evaluated the flow velocities for four storm conditions at 2-year, 10-year, 100-year and 500-year recurrence intervals, both with and without the BMP present. The maximum and average velocities for the river flow from the hydrodynamic analysis report are summarized in Table 3.2.

Table 3.2 Velocity - Hydrodynamic Model

Velocity (ft/s)	Existing Conditions (No BMP)				With BMP in Place			
	2-Year	10-Year	100-Year	500-Year	2-Year	10-Year	100-Year	500-Year
Maximum	2.79	2.68	2.95	2.95	2.68	2.93	3.14	3.14
Average	0.56	0.55	0.66	0.68	0.61	0.60	0.71	0.72

The buoys installed at the Northern Impoundment have collected velocity measurements since January 1, 2022. A total of 129,593 observations were evaluated and processed to remove unrealistic spikes in the data. The methodology is described in Attachment 3. There were 11 individual instances (10-minute each) of measurements greater than 4 ft/s, with a maximum value of 5.2 ft/s. Since these 11 instances are not sustained, they are not considered in the design parameters of the barge impact analysis.

Based on the results from the hydrodynamic model and evaluation of the buoy data, the barge impact is evaluated for a velocity between 3.14 to 4 ft/s.

## 3.7 Earthquake

The area of the Northern Impoundment is generally considered to have low seismicity. This is also reflected by the following low seismic accelerations noted in the Geotechnical Report (Appendix B).

- PGA: 0.034 g
- S<sub>s</sub>: 0.069 g
- S<sub>1</sub>: 0.040 g

Typical retaining wall structures are impacted by earthquake loads due to reduction in strength of the foundation soils, fill material and/or the backfill. Structures that are founded on saturated, cohesionless soils or lenses of such soils within the cohesive soils can lose foundation support when subject to earthquake loading.

The seismic accelerations will not affect the alluvium and Beaumont clay layers. There will be impact on Beaumont sand layers or other granular material but as the BMP walls do not extend into the sand layers, the seismic accelerations do not impact the stability of the wall.

## 4. Load Combinations

The following load combinations (LC) are appropriate for the structural design in accordance with Allowable Stress Design in ASCE 7-16.

LC# 1	$D + H + F$
LC#1A	$D + H + F + I$
LC#5	$D + H + F + 0.6W$

Where:

D = Dead load.

F = Fluid load (hydrostatic pressure).

H = Lateral earth pressures (active and passive).

W = Wind Load on surface above water.

LC#1 was evaluated for both Usual and Unusual load conditions. LC#1A was used to evaluate the barge impact as extreme load condition with impact near top of the wall. An impact at lower levels will cause less rotation in the structure.

LC#5 combines wind load with other loads acting on the BMP. It is noted that wind load is applicable only to the exposed height of BMP above ground or water level. At the design water level for Unusual or Extreme conditions (+10 ft NAVD88), the BMP exterior would not be exposed to wind.

A parametric evaluation was performed for the effect of wind loads on the design of BMP using LC#5. The 0.6 reduction factor for wind load was conservatively ignored for the evaluation. The net load ( $F + W_{\text{Exterior}} - W_{\text{Interior}}$ ) on the BMP, calculated as sum of the hydrostatic load and the wind load applied to both interior (above ground) and exterior (above water level), was compared to the hydrostatic load with water level at +10 ft NAVD88 acting alone. The net load was determined to be lower. Given that D + H are common to both load cases, LC#5 did not govern over LC#1 and was not evaluated further.

ASCE 7-16 recommends reduction in the load factor for resisting (passive) lateral earth pressure to 0.6. The intent of the reduction is to design structures resistant to overturning by reducing the resistance. Since the BMP wall was designed for overturning (rotational) stability with adequate embedment as described in Section 6, a reduction for lateral earth pressure was not considered.

## 5. Design Criteria

### 5.1 Failure Modes

The three primary failure modes for typical sheet pile retaining wall and floodwall systems are described below:

1. The unstable slopes may cause a deep-seated rotational failure of the entire soil mass. The slope failures are independent of the sheet pile embedment and location of the anchor system. This type of failure can be addressed by changing the geometry of the retained material or improving the soil strength.

*The double wall system of the BMP presented in the Third Final 100% RD is evaluated using PLAXIS 2D, a finite element software program. The program can model complex soil profiles, structural sections and perform soil-structure interaction analysis to achieve a solution with compatible forces and displacements. The program evaluates the soil stability around the sheet piles to determine if slope failure is a concern.*

- The sheet piles with inadequate embedment depth can be subjected to rigid-body rotational failure due to the lateral pressures exerted by the retained material. The classical design procedures such as the “free earth” Limit Equilibrium Method calculate the sheet pile embedment depths by balancing the active pressures behind the wall against the passive pressures provided by soil in front of the sheet piles. Adequate embedment depth is achieved at depth where the sum of horizontal forces and sum of moments is zero. Rigid-body rotational failure can be prevented, according to EM 1110-2-2504, by incorporating safety factors to decrease the passive pressures as appropriate for different loading conditions.

*The double wall system of the BMP is an atypical sheet pile system. Unlike a cantilever or anchored system, rotational failure is mitigated by the counterbalancing axial forces on the two walls. Instead of increasing the embedment depth of the single wall, the width of the double wall system can be increased to an extent such that it beneficially contributes to resolving the overturning forces into axial components along the length of the wall. Thus, this mode of failure is not applicable to the double wall system.*

- The sheet pile systems with stable slopes and adequate embedment may fail if the sheet pile sections, tie-rods, and/or the anchor components are overstressed or inadequately sized. Such failures can be prevented, according to EM 1110-2-2504, by incorporating safety factor in design by limiting the allowable stress as appropriate for different loading conditions.

## 5.2 Safety Factors

The following safety factors and allowable stress limits are adopted in the design of the BMP to prevent the failure modes described in Section 5.1, consistent with EM 1110-2-2504.

### 5.2.1 Embedment Depth

EM 1110-2-2504 recommends the minimum safety factors provided in Table 5.1 to determine embedment depth for cantilever or anchored sheet pile wall systems. It should be noted that the safety factors are suitable for the “free earth” Limit Equilibrium Method where the sheet pile is considered a rigid body allowed to rotate about a point below ground level, and the active and passive pressures are balanced to determine the embedment depth. Adequate embedment depth is achieved at depth where the sum of horizontal forces and sum of moments is zero. The pressures, and resulting forces in the system, are considered independent of the wall displacement in the Limit Equilibrium Method.

*The BMP design evaluated with the finite element analyses using soil structure interaction incorporates the nonlinear behavior of the soil, wall displacements and flexibility of the sheet pile and anchors. The active and passive pressures vary as the system flexes to achieve a solution by balancing the forces and displacements in the entire system. By balancing the forces and displacements, the system achieves a larger safety factor against rotational failure than the Limit Equilibrium Method. Thus, the safety factors are not applied to determine effective soil parameters for calculating passive pressures.*

The cantilever wall BMP presented in the 2020 Northern Impoundment 30% Remedial Design (30% RD) acted as both a floodwall and a retaining wall by maintaining differential water (higher water in the river) and soil elevations (excavation below riverbed elevation). However, the current BMP system in the new alignment primarily serves as a floodwall by maintaining a different water elevation between the excavation area and the San Jacinto River. The sheet piles are terminated in the fine grain soils of the Beaumont Clay layer and both the undrained (Q-Case) and drained (S-Case) conditions were evaluated to determine the stability of the BMP.

**Table 5.1 Safety Factors for Passive Pressures - EM 1110-2-2504**

Loading Case	Floodwalls		Retaining Walls	
	Fine-Grain Soils	Free-Draining Soils	Fine-Grain Soils	Free-Draining Soils
Usual	1.50 Q-Case	1.50 S-Case	2.00 Q-Case	1.50 S-Case
	1.10 S-Case		1.50 S-Case	

Loading Case	Floodwalls		Retaining Walls	
	Fine-Grain Soils	Free-Draining Soils	Fine-Grain Soils	Free-Draining Soils
Unusual	1.25 Q-Case 1.10 S-Case	1.25 S-Case	1.75 Q-Case 1.25 S-Case	1.25 S-Case
Extreme	1.10 Q-Case 1.10 S-Case	1.10 S-Case	1.50 Q-Case 1.10 S-Case	1.10 S-Case

## 5.2.2 Sheet Pile Sections

EM 1110-2-2504 recommends the maximum allowable stresses for the sheet piles subject to different load case conditions, included in Table 5.2. Based on the definition of the various load case conditions (Section 4), the BMP would be subject to Unusual and Extreme load case conditions less frequently than the Usual load case conditions. Hence, the allowable stresses are relatively higher for the more severe loading scenarios to provide design solutions appropriate for Unusual and Extreme load case conditions.

As noted in EM 1110-2-2504, the BMP can sustain cosmetic damage, i.e., damage that doesn't impact functionality, for Unusual load case. For Extreme load conditions, major damage that may require extensive repair or replacement of the BMP section is acceptable if the overall system remains stable.

Table 5.2 Allowable Stresses for Sheet Piles - EM 1110-2-2504

Load Case Conditions	Combined Bending and Axial Stress	Shear Stress
Usual	0.50 $F_y$	0.33 $F_y$
Unusual	0.67 $F_y$	0.44 $F_y$
Extreme	0.88 $F_y$	0.58 $F_y$

## 5.2.3 Tie-Rod Sections

The tie-rod sections are designed using allowable stress design methods in accordance with AISC 360 and the corresponding overstrength factors are provided in Table 5.3. The tie-rods are critical to balance the forces and displacements of the BMP.

Table 5.3 Overstrength Factors for Tie-Rod - AISC 360

Limit State	Overstrength Factors
Tensile Yielding	1.67
Tensile Rupture	2.00
Tensile Rupture of Threaded Parts	2.00

If one tie-rod fails, the loads will be redistributed to the adjacent tie-rods. The tie-rods are designed for 150 percent of the demand loads, accounting for a tie-rod failure event where the loads are redistributed to adjacent tie-rods and preventing progressive failure and thereby, increasing the safety factor.

## 5.2.4 Walers

The walers are longitudinal beams connected to the tie-rods on the exterior face of the sheet piles. The walers distribute the loads from the sheet piles to the tie-rods and minimize variations in displacement along the BMP. In order to provide a continuous longitudinal beam, the individual waler beams will be spliced using bolted connections.

The walers are evaluated as simply supported multi-span beams with tie-rods providing the support reactions. The walers are also evaluated for condition with a longer span (150 percent) accounting for a tie-rod failure thus able to

redistribute loads to the adjacent tie-rods. The walers are designed using the allowable stress design method in accordance with AISC 360, and the corresponding overstrength factors are provided in Table 5.4.

Table 5.4 Overstrength Factor for Walers - AISC 360

Limit State	Overstrength Factors
Flexure or Bending Stress	1.67
Shear	1.67

### 5.3 Deflection

Total system displacement comprised of structural steel deformation, rotation and translation of the entire BMP and soil system was evaluated for the proposed BMP.

Neither EM 1110-2-2504 nor ASCE 7-16 provide guidance on limiting system deflection. For a cantilever sheet pile system, structural steel can deform significantly before structural failure occurs; hence, structural steel deformation could not be used as a limiting parameter in the 30% RD.

The combination of tie-rod anchors and adequate embedment of sheet piles restrain the deflection in the sheet piles. The deflection at the top of the sheet pile translates to local deformations in the structure. These deformations are accounted for by the bending stress in the sheet piles and tensile stress in the tie-rods. The stresses will be limited to the allowable stress (Section 5.2) and within the elastic range (less than  $F_y$ ) to avoid structural failure of the BMP.

### 5.4 Corrosion Protection

The Northern Impoundment BMP structure was designed for temporary, short-term use. It was assumed that the sheet piles would remain in place for a period of approximately seven years after installation. Figure 5-1 shows the five exposure zones typically considered for corrosion. It also shows a schematic for varying thickness loss along the height of the steel sheet piles exposed to marine environment.

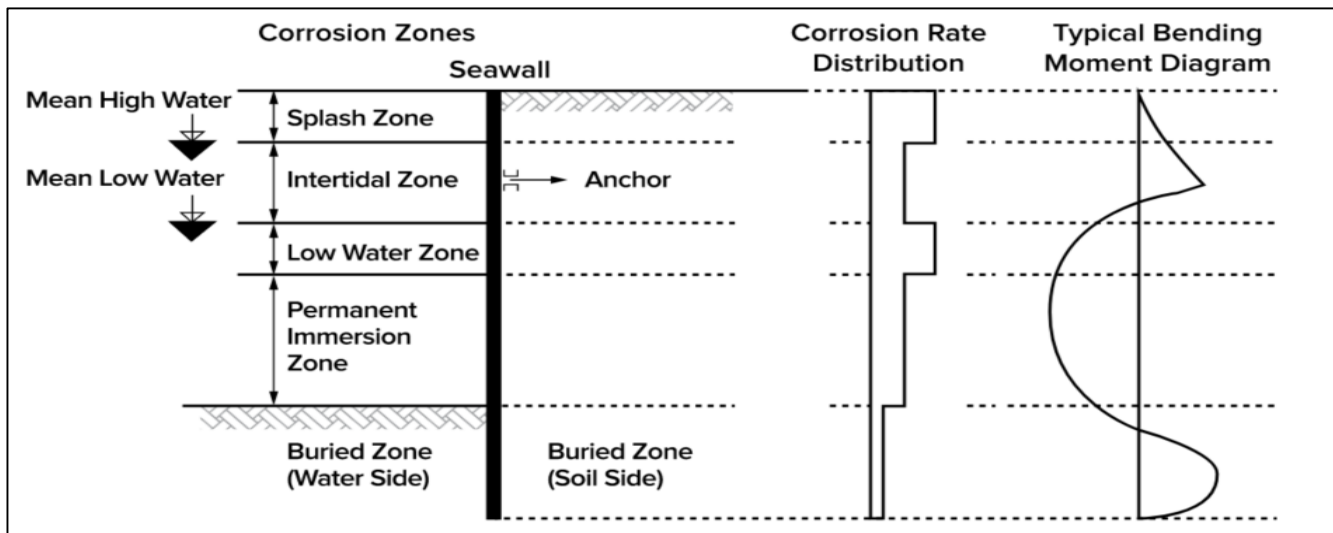

Figure 5.1 Typical Thickness Loss - Nucor Skyline Catalog, Ports & Marine Construction

The loss of thickness due to corrosion relative to different exposure conditions are listed in Table 5.5. The corrosion rates are representative of industrywide accepted rates where site specific data is unavailable. Since the Northern Impoundment is located in brackish water, an average of total thickness loss for the river (0.008 inches) and seawater (0.027 inches) exposure is appropriate (these two values are indicated in bold font in Table 5.5, below). The duration

of exposure to each zone varies significantly on the exterior and interior face of the BMP. It is conservative to assume the same thickness loss on both sides of the sheet pile. A uniform sacrificial thickness of 0.035inches (2 x 0.0175 inches) was included for each side of the sheet pile for the entire height of the wall. No additional maintenance should be required for the assumed seven-year RA period.

Table 5.5 Loss of Thickness due to Corrosion

Description of Exposure <sup>1</sup>	Loss in 5 Years <sup>1</sup> (inches)	Loss in 25 Years <sup>1</sup> (inches)	Loss in 7 Years <sup>2</sup> (inches)
Common fresh water (river, ship canal) in the zone of high attack (water line).	0.006	0.022	<b>0.008</b>
Very polluted fresh water (sewage, industrial effluent) in the zone of high attack (water line).	0.012	0.051	0.016
Sea water in temperate climate in the zone of high attack (low water and splash zone).	0.022	0.074	<b>0.027</b>
Sea water in temperate climate in the zone of permanent immersion or in the intertidal zone.	0.010	0.035	0.013

Notes:

<sup>1</sup> Eurocode 3 - Design of Steel Structures, Part 5: Piling, BS EN 1993-5:2007.

<sup>2</sup> Interpolated between 5 Years and 25 Years.

## 6. BMP Design

### 6.1 Analysis

The BMP cross-sections were analyzed for stability and determining stress in the structural components using Plaxis 2D, a finite element software program developed by Bentley Systems, Inc. The program can model complex soil profiles, structural sections and perform soil-structure interaction analysis to achieve a solution with compatible forces and displacements. The analysis also incorporates a time variable simulating the various stages of construction, such as end of sheet pile installation, adding fill between the walls, installing tie-rods, dewatering the excavation area after the BMP is installed, and excavation, to allow for consolidation or dissipation of porewater pressures. The stages and consolidation periods assumed for the analysis of each cross-section are described in Section 6.2. The consolidation periods are the minimum times assumed only for the analyses to simulate soil response and not intended to replace or alter the excavation methodology or the construction schedule for the RA.

EM 1110-2-2504 recommends applying the safety factors (Section 5.2.1) to determine the effective soil parameters used to calculate passive pressures. This recommendation is suitable for the “free earth” Limit Equilibrium Method where the sheet pile is considered a rigid body allowed to rotate about a point below ground level, and the active and passive pressures are balanced to determine the embedment depth. The pressures, and resulting forces in the system, are considered independent of the wall displacement.

The finite element analyses using soil-structure interaction incorporate the non-linear behavior of the soil, wall displacements and flexibility of the sheet pile and anchors. The active and passive pressures vary as the system flexes to achieve a solution by balancing the forces and displacements in the entire system. By inherently balancing the forces and displacements, the system achieves a larger safety factor against rotational failure than the Limit

Equilibrium Method. Thus, the safety factors are not applied to determine effective soil parameters for calculating passive pressures.

For the purposes of the analyses, the water level in the fill material between the two sheet pile walls is assumed to be at the same level as the river. Porewater pressure distributions are recalculated in steady state flow calculations following changes in water levels. Final “dewatering” of excavations assumes a phreatic level approximately one foot below the excavation level in the excavation area. No dewatering from well points below the excavation or wall was considered.

The program provides outputs of resultant forces such as shear and moment for the sheet piles, tension force for the tie-rod, and deflection at each stage of analysis. The structural components are designed for the largest governing forces. The representative sections along the BMP are described in Section 6.2 and the definition in Plaxis at initial stage is shown in Attachment 2. The analysis results for each of the analysis sections (described in Section 6.2) are included in Attachment 3.

## 6.2 Analysis Sections

The BMP behavior varies with the height of the sheet piles above riverbed and the subsurface strata. Hence, multiple cross-sections were evaluated to account for the variations in riverbed elevations, cross-slope of the riverbed along the BMP alignment, thickness of Alluvium Sediments, anticipated top of Beaumont Clay layers, and distance from the BMP to excavation. The extents of each cross-section are shown in Figure 6-1. These extents are approximate and may change in the final construction to accommodate considerations related to standardizing construction practices.

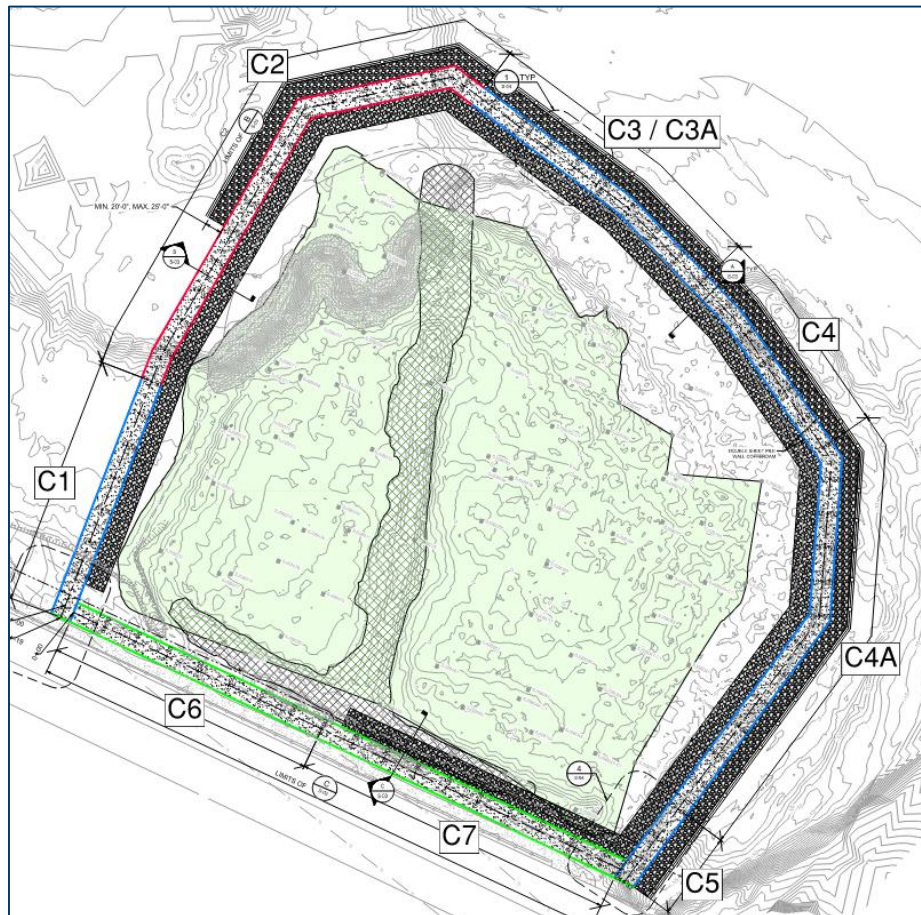

Figure 6.1 General Extents of the Analysis Cross-Sections

The following sections present the various cross-sections analyzed to determine the appropriate embedment depth for the sheet piles to achieve stability, size the sheet piles and tie-rods for the BMP. The cross-sections show distance on the horizontal axis and elevation (NAVD88) on the vertical axis. The sheet piles are typically centered at distance 0 on the horizontal axis as the cross-sections are taken along the BMP alignment. The cross-sections also show the approximate excavation surface near the BMP. The distance to the excavation area varies along the BMP alignment but the cross-sections are considered representative for the extents shown in Section 6.2.

Since the 90% RD, the BMP is evaluated for additional loading scenario with river flood stage water elevation of +10 ft NAVD88. The exterior wall is raised to elevation +10 ft in the Third Final 100% RD drawings. The tie-rod elevations (elevation +3 ft) are raised to be located above the normal water level in the river (elevation +2 ft).

The following sections provide the sequence of construction for each cross-section. The overall construction sequence is subject to the Contractor's means and methods and must be reviewed and approved by the Engineer.

## 6.2.1 Cross-Section C1

Cross-Section C1 (Figure 6-2) represents the site condition where the riverbed is sloping away from the Northern Impoundment. The approximate wall height on the exterior and interior side is 20 ft and 16 ft, respectively.

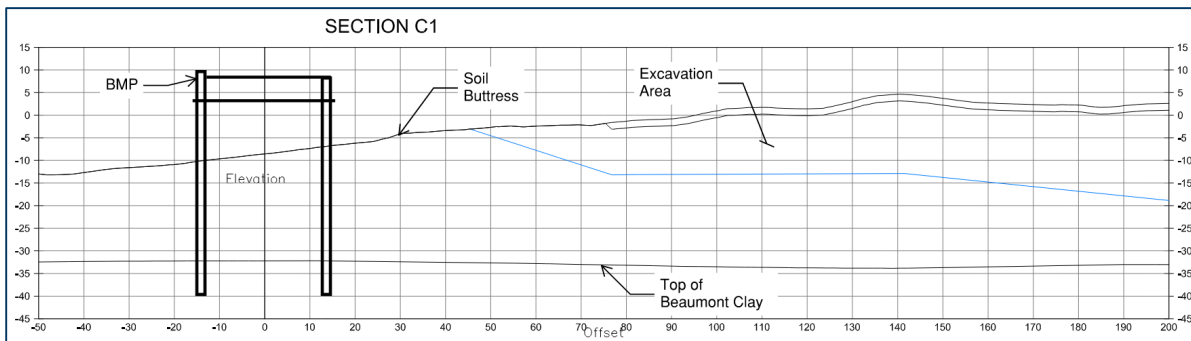

Figure 6.2 Analysis Cross-Section C1

The following construction stages and consolidation periods were defined for the analysis of Cross-Section C1:

1. Install exterior and interior sheet piles.
2. Fill between the sheet piles to elevation +3 ft NAVD88. Minimum time interval assumed as 10 days.
4. Install tie-rods at elevation +3 ft NAVD88.
5. Fill between the sheet piles to elevation +9 ft NAVD88. Minimum time interval assumed as 6 days.
6. Dewater BMP interior to riverbed. Minimum time interval assumed as 4 days.
7. Excavate to 50 percent depth of material to be removed. The minimum time interval is assumed as 14 days.
8. Dewater to final level (-20 ft NAVD88). Minimum time interval assumed as 3 days.
9. Excavate to 100 percent depth of material to be removed. The minimum time interval is assumed as 14 days.

## 6.2.2 Cross-Section C2

Cross-Section C2 (Figure 6-3) represents the site condition where the riverbed is fairly even along the BMP alignment. The approximate wall height on both the exterior and interior sides is 25 ft and 24 ft respectively. The large height above the riverbed overstressed the sheet piles and tie-rods. Hence, a 30 ft wide Raised Bench constructed up to elevation -4 ft NAVD88 is required on the interior side of the BMP to reduce the stresses.

The sheet piles and tie-rods required for Cross-Section C2 are among the largest standard sections available. The tie-rods are required to be installed at elevation +3 ft NAVD88.

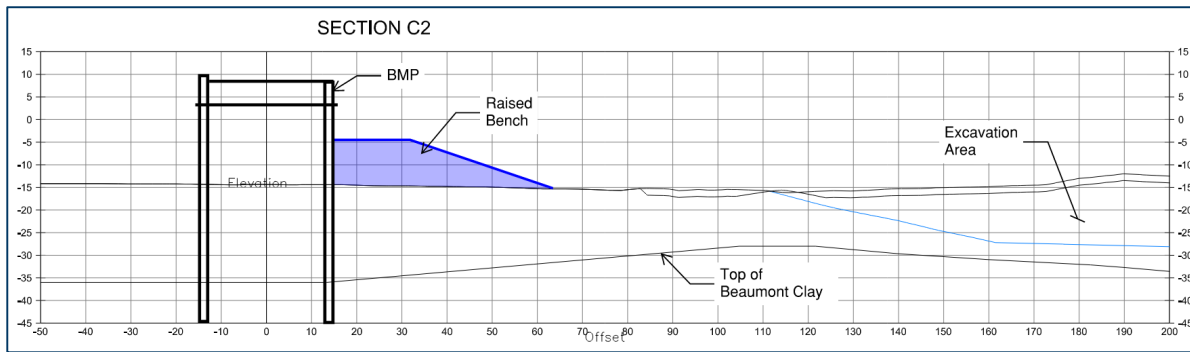

Figure 6.3 Analysis Cross-Section C2

The following construction stages and consolidation periods were defined for the analysis of Cross-Section C2:

1. Install exterior and interior sheet piles.
2. Fill between the sheet piles to elevation -7 ft NAVD88. The minimum time interval is assumed as 7 days.
3. Install tie-rods at elevation +3 ft NAVD88.
4. Fill between the sheet piles to elevation -1 ft NAVD88. The minimum time interval is assumed as 7 days.
5. Fill between the sheet piles to elevation +5 ft NAVD88. The minimum time interval is assumed as 7 days.
6. Fill between the sheet piles to elevation +9 ft NAVD88. The minimum time interval is assumed as 7 days.
7. Install raised bench to elevation -9 ft, sloped at 3H:1V. Wait 7 days.
8. Install raised bench from elevation -9 ft to elevation -4 ft at same slope. Wait 7 days before dewatering.
9. Dewater BMP interior to riverbed. The minimum time interval is assumed as 4 days.
10. Excavate to 50 percent depth of material to be removed. The minimum time interval is assumed as 14 days.
11. Dewater to final level. The minimum time interval is assumed as 3 days.
12. Excavate to 100 percent depth of material to be removed. The minimum time interval is assumed as 14 days.

This cross-section was analyzed assuming excavation methodology assuming excavation is completed in the wet. It should be noted that the areas in the northwest corner are subject to risk of hydraulic heave as described in the Geotechnical Report (Appendix B) and modified excavation methodology will be required in some areas of the northwest corner.

### 6.2.3 Cross-Sections C3 and C3A

Cross-Sections C3 and C3A (Figure 6-4 and Figure 6-5, respectively) represent the site condition where the riverbed is fairly even along the BMP alignment. The riverbed starts sloping toward the excavation area along Cross-Section C3. The approximate wall height on both the exterior and interior sides is 15 ft and 14 ft respectively.

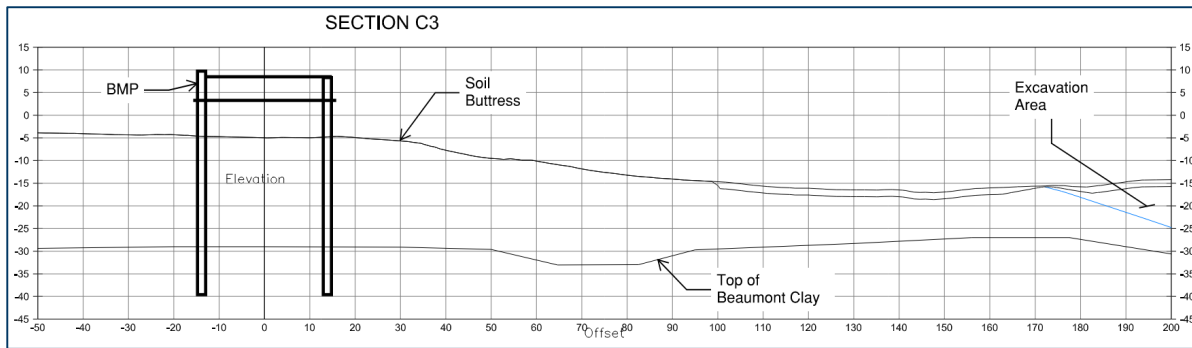

Figure 6.4 Analysis Section C3

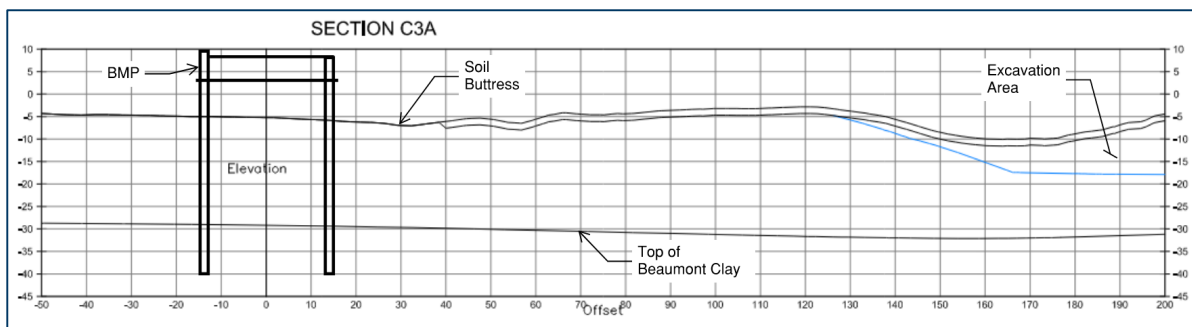

Figure 6.5 Analysis Section C3A

The following construction stages and consolidation periods were defined for the analysis of Cross-Section C3:

1. Install exterior and interior sheet piles.
2. Fill between the sheet piles to elevation 0 ft NAVD88. The minimum time interval is assumed as 10 days.
3. Install tie-rods at elevation +3 ft NAVD88.
4. Fill between the sheet piles to elevation +3 ft NAVD88. The minimum time interval is assumed as 3 days.
5. Fill between the sheet piles to elevation +9 ft NAVD88. The minimum time interval is assumed as 10 days.
6. Dewater BMP interior to riverbed. The minimum time interval is assumed as 4 days.
7. Excavate to 50 percent depth of material to be removed. The minimum time interval is assumed as 14 days.
8. Dewater to final level (-26 ft NAVD88). The minimum time interval is assumed as 3 days.
9. Excavate to 100 percent depth of material to be removed. The minimum time interval is assumed as 14 days.
10. As the limits of Cross-Section C3 and Cross-Section C3A overlap, the more conservative approach for Cross-Section C3 is used for both.

## 6.2.4 Cross-Section C4

Cross-Section C4 (Figure 6-6) represents the site condition where the riverbed slopes away steeply from the Northern Impoundment. The approximate wall heights on the exterior and interior sides are 23 ft and 12 ft, respectively.

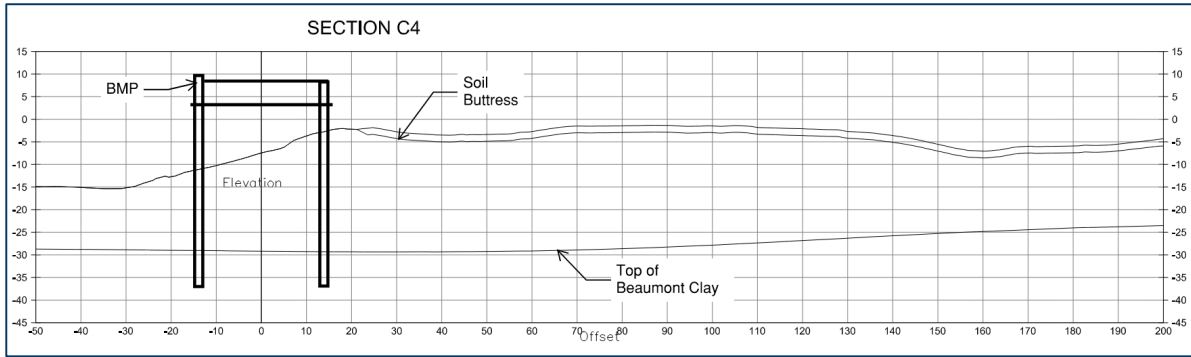

Figure 6.6 Analysis Section C4

The following construction stages and consolidation periods were defined for the analysis of Cross-Section C4:

1. Install exterior and interior sheet piles.
2. Fill between the sheet piles to elevation -3 ft NAVD88. The minimum time interval is assumed as 10 days.
3. Install tie-rods at elevation +3 ft NAVD88.
4. Fill between the sheet piles to elevation +9 ft NAVD88. The minimum time interval is assumed as 6 days.
5. Dewater BMP interior to riverbed. The minimum time interval is assumed as 4 days.
6. Excavate to 50 percent depth of material to be removed. The minimum time interval is assumed as 17 days.
7. Dewater to final level (-22 ft NAVD88). The minimum time interval is assumed as 3 days.
8. Excavate to 100 percent depth of material to be removed. The minimum time interval is assumed as 14 days.

## 6.2.5 Cross-Section C4A

Cross-Section C4A (Figure 6-7) represents the site condition where the riverbed slopes away from the Northern Impoundment. The approximate wall heights on the exterior and interior sides are 18 ft and 12 ft, respectively.

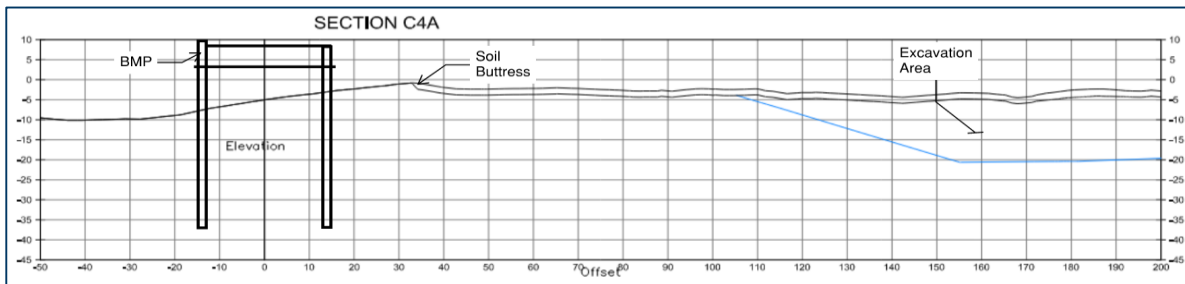

Figure 6.7 Analysis Section C4A

The following construction stages and consolidation periods were defined for the analysis of Cross-Section C4A:

1. Install exterior and interior sheet piles.
2. Fill between the sheet piles to elevation 0 ft NAVD88. The minimum time interval is assumed as 10 days.
3. Install tie-rods at elevation +3 ft NAVD88.
4. Fill between the sheet piles to elevation +9 ft NAVD88. The minimum time interval is assumed as 6 days.
5. Dewater BMP interior to riverbed. The minimum time interval is assumed as 4 days.
6. Excavate to 50 percent depth of material to be removed. The minimum time interval is assumed as 17 days.
7. Dewater to final level (-21 ft NAVD88). The minimum time interval is assumed as 3 days.
8. Excavate to 100 percent depth of material to be removed. The minimum time interval is assumed as 14 days.

## 6.2.6 Cross-Section C5

Cross-Section C5 (Figure 6-8) represents the site condition where the riverbed slopes away steeply from the Northern Impoundment. The approximate wall heights on the exterior and interior sides are 25 ft and 17 ft, respectively.

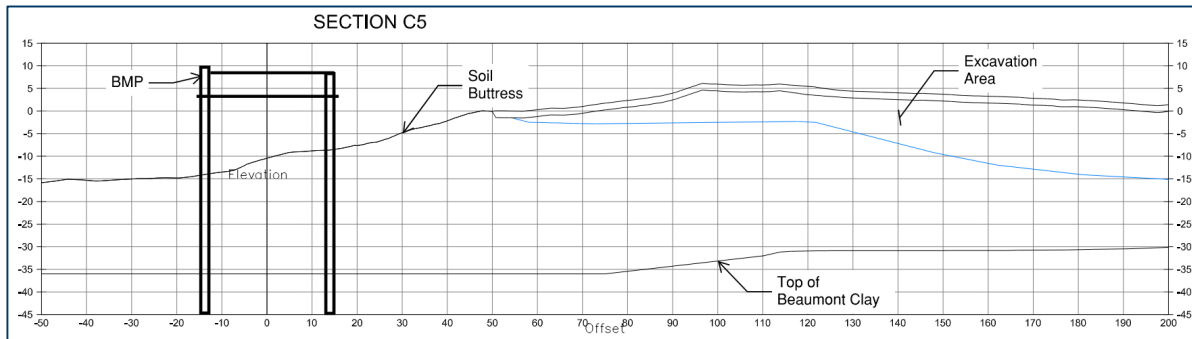

Figure 6.8 Analysis Section C5

The following construction stages and consolidation periods were defined for the analysis of Cross-Section C5:

1. Install exterior and interior sheet piles.
2. Fill between the sheet piles to elevation -1 ft NAVD88. The minimum time interval is assumed as 10 days.
3. Install tie-rods at elevation +3 ft NAVD88.
4. Fill between the sheet piles to elevation +9 ft NAVD88. The minimum time interval is assumed as 6 days.
5. Dewater BMP interior to riverbed. The minimum time interval is assumed as 4 days.
6. Excavate to 50 percent depth of material to be removed. The minimum time interval is assumed as 17 days.
7. Dewater to final level (-16 ft NAVD88). The minimum time interval is assumed as 3 days.
8. Excavate to 100 percent depth of material to be removed. The minimum time interval is assumed as 14 days.

## 6.2.7 Cross-Sections C6 and C7

Cross-Sections C6 and C7 (Figure 6-9 and Figure 6-10, respectively) represent the BMP cross-sections along the southern alignment parallel to I-10. The TxDOT right of way (ROW) runs between the elevated portion of the freeway and the southern boundary of the Northern Impoundment. The existing ground elevation varies between elevation 0 ft NAVD88 and +5 ft NAVD88. The elevation at bottom of excavation is at -14 ft NAVD88 and -20 ft NAVD88 for Section C6 and Section C7, respectively. For these cross-sections, the top of the Soil Butress was considered to be at elevation 0 ft NAVD88 at the face of the BMP. This assumption is conservative for BMP design as the Soil Butress extends higher, to elevation +5 ft NAVD88 in some locations, providing additional stability and reducing the retained height of the wall.

Several alternatives as described in this section were evaluated to identify a workable BMP design for Cross-Sections C6 and C7. The BMP for these cross-sections was originally evaluated as a combination wall (Alternative 1), to be installed directly at the edge of the existing Northern Impoundment berm (0 on the horizontal axis) and with excavation limits extending to the face of the sheet piles. It was originally conceived that this type of wall would be the simplest design and installation for this area, although it required the installation of tie-back anchors on the TxDOT ROW. However, the combination wall and several other alternatives were each determined not to be feasible, for reasons described below.

The only workable solution identified was a double-wall system, approximately 30 ft wide, similar to the double-wall system planned for the remainder of the BMP around the Northern Impoundment (Alternative 5). This double-wall system required moving the BMP alignment farther south into the TxDOT ROW to allow for a sloped Soil Butress

beginning at Elevation 0 ft NAVD88 and extending into the excavation area. This placed the double wall within the TxDOT ROW, with the outer wall being approximately 20 ft from the I-10 Bridge guardrails on the TxDOT ROW.

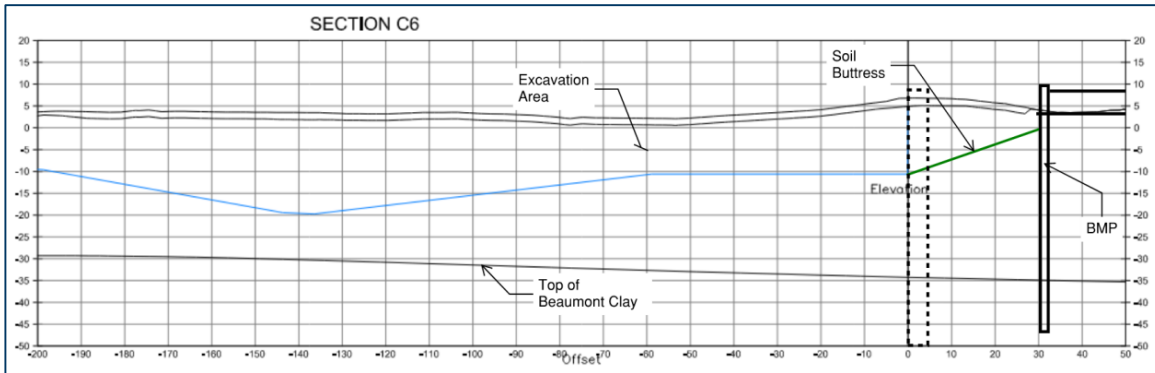

Figure 6.9 Analysis Section C6

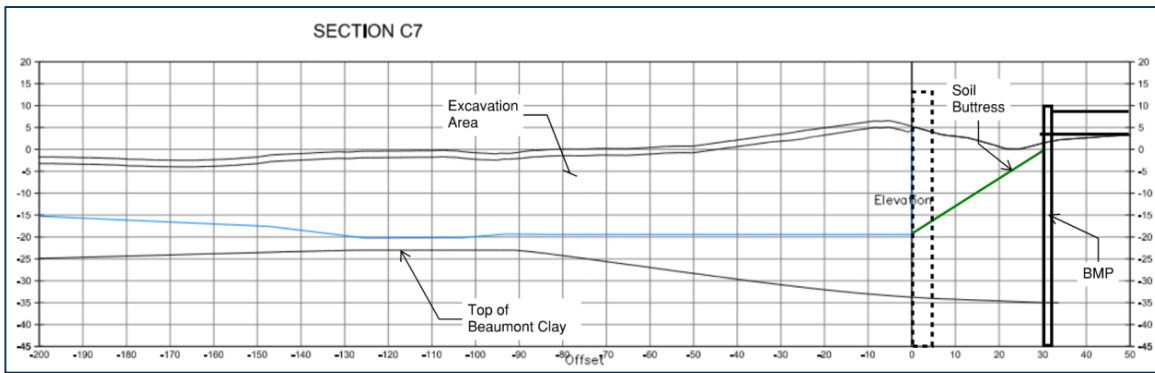

Figure 6.10 Analysis Section C7

The different wall types that were evaluated for the BMP along the southern alignment are detailed below.

### Alternative 1: Combination Wall with Tie-back Anchors

This alternative included a combination wall system of tubular pipe piles and Z-shaped sheet piles aligned directly at the edge of the existing berm and excavation limits, and connected to the Z-shaped sheet pile anchor walls with steel tie-rods for support. The wall would have been approximately 23 ft to 29 ft above the bottom of the excavation. Due to the significant height of wall above the anticipated excavation bottom and the need for active excavation at the face of the BMP (such that there would not be any Soil Buttress between the excavation and the BMP wall, as in other BMP cross-sections), it was determined that the pipe piles for this alternative would have to be driven into the hard sand layers located beneath the Beaumont Clay to achieve adequate embedment depth for stability. For this alternative, tie-back anchors would have been required to provide adequate anchorage for the pipe piles and avoid rotational failure. These tie-back anchors would have been placed at least 60 ft behind the pipe piles on the TxDOT ROW, close to the southern boundary of the ROW adjacent to I-10.

There were significant concerns related to driving the BMP wall into the sand layer which would have presented problems with driveability and associated vibrations when installing large tubular sections (Section 6.6), particularly in such close proximity to the I-10 Bridge, the ExxonMobil pipeline assets, and other underground utilities. There were also concerns for vehicle driver safety due to potential visual distraction during installation of a wall of this magnitude and height adjacent to I-10. In addition, extracting the tubular piles after completion of the RA would have raised concerns similar to those associated with their installation. For these reasons, this option was considered unfeasible.

## **Alternative 2: Cantilever Concrete Secant Pile**

This alternative included overlapping concrete piles aligned directly at the edge of the existing berm and excavation limits. All piles would have had to be cast-in-place by drilling to the required depth, placing reinforcement, and pouring concrete. The primary concrete piles (typically unreinforced) would have had to be built first at regular interval spacing to allow for secondary reinforced concrete piles to be installed in between them. After the primary piles had achieved the desired strength, the secondary reinforced concrete piles would have had to be built by coring through the edges of the primary piles, placing reinforcement, and pouring concrete to create an overlapping continuous concrete wall. The secondary piles could not be drilled until after the primary piles had achieved full strength resulting in longer installation time than steel piles. The concrete piles would also have been required to be embedded in the hard sand layers beneath the Beaumont Clay to achieve adequate embedment depth for stability.

There were concerns about the constructability of this system since it would have required drilling deep into the sand layer and use of steel casings to allow placement of concrete in the sand layers, further extending the installation time. It also would have required achieving quality overlap between primary and secondary piles to create relatively watertight seams and avoid any seepage of any water into or out of the Northern Impoundment, which would have been extremely challenging to achieve. Finally, the large unrestrained height of the wall above the excavation area (up to 29 feet, similar to Alternative 1) would have also been a concern for safety. Removal of the cast-in-place concrete piles without extensive demolition also would not have been feasible. Hence, this alternative was considered unfeasible.

## **Alternative 3: Concrete Secant Pile with Tieback Anchors**

This alternative included installation of concrete piles similar to Alternative 2 combined with the tie-back anchors similar to Alternative 1, aligned directly at the edge of the existing berm and excavation limits and with the tie-back anchors extending into the TxDOT ROW. Due to concerns similar to those that were the basis for eliminating Alternative 1 and Alternative 2, this alternative was considered unfeasible.

## **Alternative 4: Combination Wall with Brace Piles**

This alternative included a combination wall system similar to Alternative 1 with the tie-back anchor system behind the wall replaced by brace piles located in front of the wall. The BMP was aligned directly at the edge of the existing berm and excavation limits. The brace piles would have been closely spaced large diameter tubular piles similar to the ones in the combination wall and installed at an angle of 35 degrees (from vertical) within the excavation area. Excavation would have to take place around these brace piles. Similar to Alternative 1, the combination wall would have had to be driven into the sand layers to achieve adequate embedment depth. In addition, the brace piles would also have had to be driven into the sand layers to achieve the required capacity to adequately brace the combination wall.

The concerns with constructability as described for tubular piles in Alternative 1 also apply to the combination wall and brace piles. There would also be a potential risk for critical damage and worker safety issues associated with excavating around the brace piles to an elevation of -20 ft NAVD88. Hence, this alternative was considered unfeasible.

## **Design System: Double Wall System**

This alternative is the same as the other cross-sections of the BMP. The BMP alignment was set farther away from the edge of the existing berm and excavation limits, and approximately 20 ft from the southern boundary (immediately adjoining I-10) of the TxDOT ROW. This alignment avoids encroaching into the excavation area and allows utilization of the existing berm to act as a Soil Buttress to reduce the retained height the wall and reduced stresses on the structural components of the BMP wall.

This alternative provides a feasible BMP design that is placed outside the excavation area and avoids the concern of pile drivability and vibrations since the sheet piles would be terminated in the Beaumont Clay layer. However, it will require use of the TxDOT ROW to accommodate the BMP wall structure.

## Design Selection: Double Wall System

The double wall system as described in Alternative 5 was selected as the BMP along the southern alignment. The following construction stages and consolidation periods were defined for the analysis of Cross-Sections C6 and C7:

1. Install exterior and interior sheet piles.
2. Cut soil between the sheet piles to elevation 0 ft NAVD88.
3. Install tie-rods at elevation +3 ft NAVD88.
4. Fill between the sheet piles to elevation +9 ft NAVD88.
5. Dewater BMP interior to riverbed. The minimum time interval is assumed as 4 days.
6. Excavate to 50 percent depth of material to be removed. Maintain soil slope at 3H:1V from elevation 0 ft NAVD88 to excavation bottom. The minimum time interval is assumed as 17 days.
7. Dewater to final level (-20 ft NAVD88). The minimum time interval is assumed as 3 days.
8. Excavate to 100 percent depth of material to be removed. Maintain minimum soil slope at 3H:1V from elevation 0 ft NAVD88 to excavation bottom. The minimum time interval is assumed as 14 days.

## 6.3 Structural Components

The material grades used for design of the key structural components are summarized below:

- **Sheet Piles**      ASTM A572      Grade 60 (Yield stress,  $F_y = 60$  ksi).
- **Tie rods**        ASTM A615      Grade 80 ( $F_y = 80$  ksi).
- **Walers**          ASTM A36        Grade 36 ( $F_y = 36$  ksi).

For purposes of the design, the standard sections for sheet pile and tie-rods were selected from the Nucor Skyline Technical Product Manual. The manual also included the section properties used for design calculations. Alternative sections with equivalent properties are available from other manufacturers and may be used in construction.

The detailed calculations for the sheet pile, tie-rods, and walers are provided in Attachment 3.

## 6.4 Scour Protection

### 6.4.1 BMP Exterior

Scour protection countermeasures for the BMP exterior are developed based on Federal Highway Administration (FHWA) guidance provided in Hydraulic Engineering Circular No. 23 (HEC-23), Bridge Scour and Stream Instability Countermeasures (Publication No. FHWA-NHI-09-111, September 2009) which provides design guidelines for use of rock riprap to mitigate scour at bridge abutments. Although the BMP is not a bridge abutment, its influence on floodplain hydraulics is similar in that overbank flows are concentrated through a narrower section of the river resulting in localized increase in shear stress.

Design Guideline 14 was applied to the design of the rock riprap scour protection concepts. The median stone diameter for riprap scour protection is calculated based on depth, velocity and abutment geometry using the Isbash equation. The results from the Hydrodynamic Analysis (Appendix F) indicate maximum peak velocities would be approximately 3.14 ft/s. To account for uncertainties related to complex hydrodynamics and potential for localized flow accelerations along the BMP, an additional safety factor was applied to the predicted maximum velocity. The median rock size for the riprap was designed for a velocity of 6 ft/s.

Based on this approach, the riprap scour protection apron will consist of a median stone diameter of 10 inches and an overall layer thickness of 1.5 ft.

As noted in Section 3.3.1, scour protection is required around the majority of the perimeter of the wall, including the east side of the BMP as the channel narrows near the I-10 Bridge. A 25 ft wide riprap apron will provide sufficient stability along the exterior perimeter of the BMP.

Additional details of various scenarios considered for riprap sizing are provided in Attachment 3.

## 6.4.2 BMP Interior

Scour protection countermeasures for the BMP interior are designed by calculating the velocity of water reaching the base of the wall, resulting impact pressure, length of the turbulent flow at the base of the wall and potential for flow jump where the soil slopes away from the wall.

The most critical scour can occur in the initial stages where the river water level rises over the top of the BMP wall. When water rises 6 inches above the BMP wall, it can fill the entire area to the top of the wall within 1-2 hours. As the river water level continues to rise in the initial hours, the BMP will fill faster and reduce the time where the soils at the base of the BMP are directly exposed to the overtopping water.

Additional details of the analysis for a wide range of river water levels between elevation +10.1 ft to +14.0 ft are provided in Attachment 3.3. However, only the initial stages where water level reaches elevation +10.5 ft is considered critical for interior wall scour.

Based on this approach, the interior riprap scour protection will consist of median stone diameter of 18 inches and an overall layer thickness of 3 ft. As an added measure, the riprap will be grouted with flowable concrete of 3000 psi strength to withstand the plunging water flow over the BMP wall. The riprap apron will be extended to 25 ft from the base of the BMP wall.

At the northwest corner of the BMP, the raised bench is required for stability of the wall. Due to limited space available without encroaching into the excavation area, the riprap will be incorporated into the bench to protect the entire 30-ft width of the raised bench. All the interior scour protection will be monitored routinely and maintained for the duration of the project.

Additional details of various scenarios considered for riprap sizing are provided in Attachment 3.

## 6.5 Wind Load Evaluation

As described in Section 3.5, the design wind loads correspond to a 100-year storm (Unusual load condition) or the 3000-year hurricane level wind (Extreme load condition). Typically, the wind load is applied to the face of the BMP exposed above water or ground level. At the design water level for the Unusual and Extreme load conditions (i.e., Elevation +10 ft NAVD88) the exterior face of the BMP would not be exposed to the wind. Assuming the excavation area remained completely dewatered, the wind loads acting on the interior face of the BMP will be counteracted by the hydrostatic loads from the water on the outside.

A parametric evaluation was performed for the effect of wind loads on the design of BMP using LC#5 (Section 4). The 0.6 reduction factor for wind load was conservatively ignored for the evaluation. The net load ( $F + W_{\text{Exterior}} - W_{\text{Interior}}$ ) on the BMP, calculated as sum of the hydrostatic load and the wind load applied to both interior (above ground) and exterior (above water level), was compared to the hydrostatic load with water level at +10 ft NAVD88 acting alone. There is low probability that the hurricane level winds will develop on-site without an increase in water levels. Hence, combining hurricane level winds with normal water levels (i.e., Elevation +5 ft NAVD88) when the BMP is most exposed, is a conservative approach. The calculated net load was smaller than the hydrostatic loads corresponding to the unusual condition water level at +10 ft (NAVD88) acting alone. Thus, the wind loads do not govern the design.

Additional details of various scenarios considered for the parametric evaluation are provided in Attachment 3.

## 6.6 Wave Load Evaluation

As described in Section 3.5, the BMP is designed for water levels at top of the wall. Hence, the loads from waves approaching the BMP wall and combined with lower water levels will not govern the design.

## 6.7 Barge Impact

The impact energy from a barge moving at the river flow velocity will be absorbed in the following two stages:

1. Primary or first contact will be with a barrier wall system comprising of fiberglass reinforced polymer (FRP) composite piles. The barrier wall is designed to absorb impact energy corresponding to velocity of up to 2.2 ft/s (laden barge) or up to 5.3 ft/s (ballasted barge).
2. As the barge damages the barrier wall and breaks through, it will lose energy. The BMP will be subjected to the remaining energy of 1.8 ft/s i.e., energy corresponding to the difference between approach velocity of 4 ft/s and energy absorbed by the barrier wall at 2.2 ft/s. In the 90% RD, the BMP was evaluated for impact velocity of 2.2 ft/s (laden barge) and 5.3 ft/s (ballasted barge). The analysis was updated for the same load impact at a higher elevation i.e., between elevation +9 ft and +10 ft NAVD88 (top of exterior wall).

Thus, the total energy from barge impact is compared against the combined energy absorption capacity of the individual systems (i.e., the FRP barrier wall and the BMP wall) to evaluate adequacy of the design. The details for each system are provided in the Section 6.7.1 and Section 6.7.2.

Any impact on the west and northwest portion of the BMP (i.e., areas away from the navigational waterways) will likely be from ballasted barges moored on the north side of the BMP that may come off the mooring in a storm event. Cross-Section C2 is evaluated as a representative section for such portions of the BMP. The total energy absorption capacity is equivalent to impact with a ballasted barge at impact velocity of 5 ft/s (2.2 ft/s for FRP wall + 3.8 ft/s for BMP wall).

For areas of the BMP directly adjacent to the navigational waterways, such as Cross-Section C4, the total energy absorption capacity is equivalent to impact with a laden barge at impact velocity of 4.4 ft/s (2.2 ft/s for FRP wall + 2.2 ft/s for BMP wall) or a ballasted barge at impact velocity of 7.5 ft/s (2.2 ft/s for FRP wall + 5.3 ft/s for BMP wall).

As the velocity for the system capacity is greater than the design velocity of 4 ft/s for the river flow (Section 3.6.2), the combined system is adequately designed.

### 6.7.1 Barrier Wall

A FRP barrier wall will be installed at approximately 20 to 25 ft beyond the exterior wall of the BMP along the north and east side to provide increased protection in areas exposed to potential barge impacts. See Figure 6.11. The barrier wall will be comprised of 18-inch diameter FRP composite piles spaced at 8 ft on center. Four rows of 12-inch x 12-inch reinforced high-density polyethylene (HDPE) walers will be installed horizontally on the exterior side of the FRP piles, evenly spaced between Elevation +2 and +12 ft above mean water level (Figure 6.12).

The barge will contact the walers and in turn, multiple FRP piles will be engaged, and the barrier wall system will deflect to absorb the impact energy. The system is designed to absorb impact from the design barge up to a velocity of 2.2 ft/s (laden) and 5.3 ft/s (ballasted barge) between elevation +0.5 ft to +12 ft NAVD88. The largest moment demands on the pile sections are seen when the barge impact is at or near the top of the barrier wall. At lower elevations of impact, the moment demands are lower and do not govern the design.

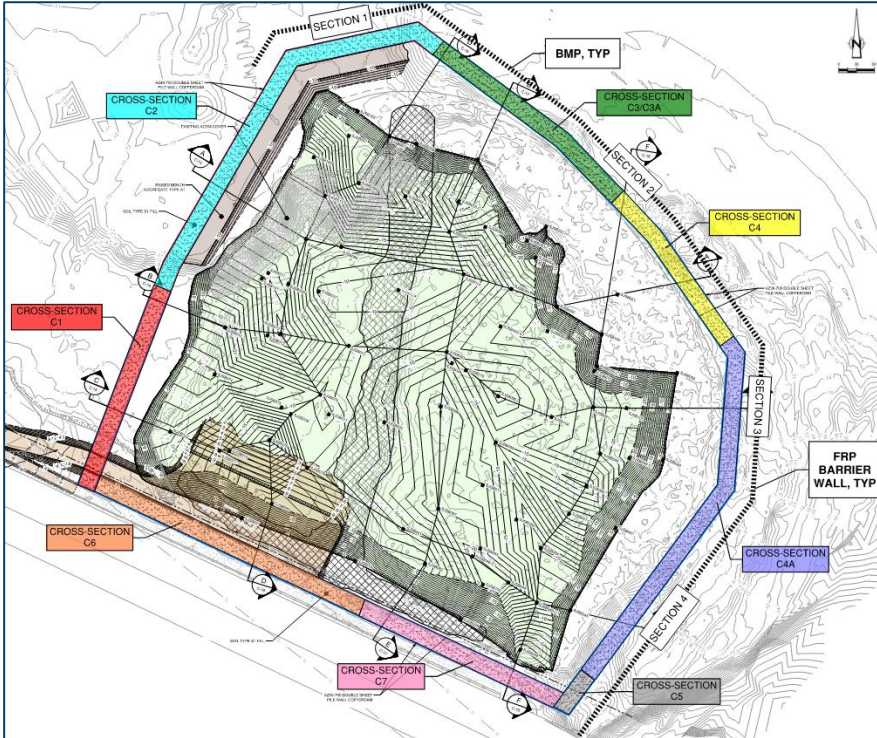

Figure 6.11 FRP Barrier Wall – Alignment

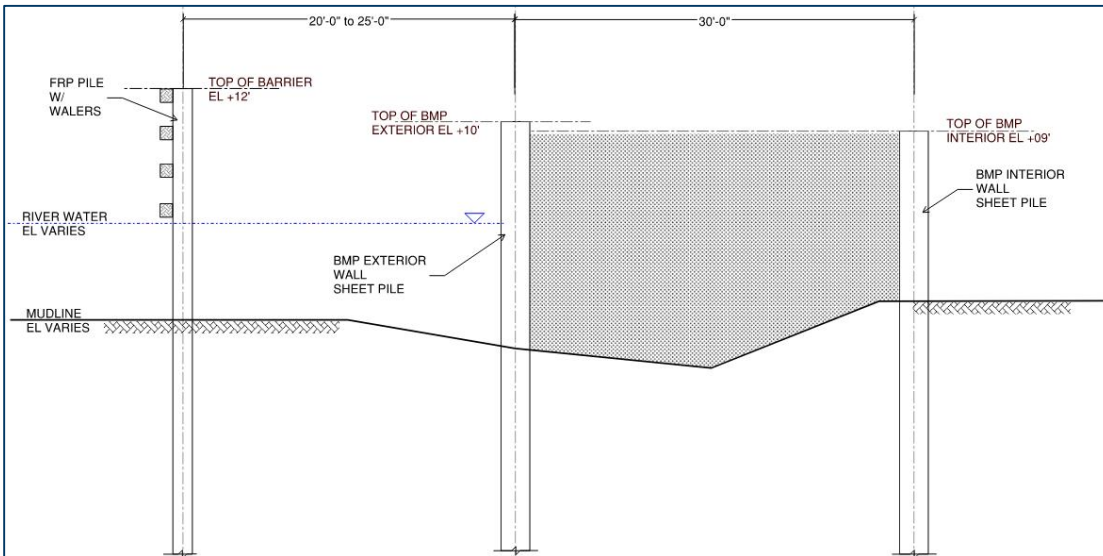

Figure 6.12 FRP Barrier Wall – Typical Section

The details of the analysis and results are provided in Attachment 3.

## 6.7.2 BMP Impact

The BMP was analyzed for barge impact near the top of the wall (exterior sheet pile). With the FRP barrier wall system as the primary protection, the BMP will absorb the excess impact energy equivalent to an impact from the design barge at velocity of 1.8 ft/s.

In the 90% RD, the BMP was evaluated for impact at a higher velocity, so the same analysis results (demand loads on BMP sheet pile) are valid for the current evaluation of impact at lower velocity.

### 6.7.2.1 Analysis Model

The barge impact loads were evaluated in Plaxis for two Cross-Sections (C2 and C4) as they represent the two largest exposed heights above the riverbed and are expected to be the most critical sections.

A 400 ft long three-dimensional (3D) model was created with the same stratigraphy, material properties and stages as the analysis sections described in Section 6.2. The linear elastic plates representing the sheet piles are assigned orthotropic parameters to capture the difference in sheet pile stiffness of the vertical and horizontal directions. The barge impact load was applied at the middle of the model, as a static uniformly distributed load over a 50 ft x 1 ft area near the top of the wall (+9 ft NAVD88). Due to the instantaneous nature of the impact, the loads are evaluated using the undrained soil parameters and considered an Extreme load condition, with the impact near the top of the wall with the water levels at +10 ft NAVD88.

The following two loading scenarios, considering a combination of multiple impact velocities and barge displacement conditions (ballasted or laden), were evaluated. The loads correspond to higher velocities of flow for impact, than as summarized in Table 3.2, with a barge in ballasted condition, hence conservative for the analysis. However, for the laden condition, the loads represent the limiting loads for the BMP.

*Case 1: 20 kip/ft x 50 ft = 1000 kip*

- Corresponds to contact with 54 ft wide barge in ballasted condition at impact velocity of 3.8 ft/s or,

*Case 2: 28 kip/ft x 50 ft = 1400 kip*

- Corresponds to contact with 54 ft wide barge in ballasted condition at impact velocity of 5.3 ft/s or,
- Contact with 54 ft wide barge in laden condition at impact velocity of 2.2 ft/s.

As Cross-Section C2 is not near the navigational waterway, any impact on the west and northwest portion of the BMP will likely be from barges moored on the north side of the BMP that may come off the mooring in a storm event. Thus, Cross-Section C2 is only evaluated for Case 1 loading scenario. The results from Cross-Section C4 are applicable to all other locations, except Cross-Section C2.

The barge impact loads caused localized deformation of the wall along with an increase in soil shear strains. However, the strains did not indicate global failure. In this scenario, there would be localized damage to the BMP on the exterior side due to limiting flexural capacity. The analysis results are summarized in Table 6.1 and Table 6.2. The section stresses from demand loads are compared to the allowable stresses in the sheet piles for extreme event loading i.e., 0.88 Fy (combined bending moment and axial stress) and 0.58 Fy (shear stress) to estimate overstress beyond the allowable limit. The section stresses from demand loads are also compared to the elastic yield stresses in the sheet piles i.e., 1.0 Fy (combined bending moment and axial stress) and 1.0 Fy (shear stress) to estimate damage that will require repair.

*The section sizes for Cross-Section C2 and C4 have been increased since the 90% RD to increase the section modulus and shear area of the sheet piles. The impact loads are applied from elevation +9 ft to +10 ft on the exterior wall of the BMP.*

Table 6.1 Barge Impact Analysis Output – Extreme Allowable Stress

Analysis Cross-Sections	Analysis Demands per LF			Sheet Pile Capacity (Extreme Load Condition)		Demand to Capacity Ratio	
	Moment (kip-ft)	Shear (kip)	Deflection (ft)	Moment (kip-ft)	Shear (kip)	Moment	Shear
C2, AZ 42-700N (Case 1)	405.3	32.1	1.5	342	375	1.18	0.09
C4, AZ 36-700N (Case 1)	270.4	26.6	1.1	292	300	0.93	0.09
C4, AZ 36-700N (Case 2)	376.2	36.7	2.1	292	300	1.29	0.12

Table 6.2 Barge Impact Analysis Output – Elastic Yield Stress

Analysis Cross-Sections	Analysis Demands per LF			Sheet Pile Capacity (Elastic Yield Limit)		Demand to Capacity Ratio	
	Moment (kip-ft)	Shear (kip)	Deflection (ft)	Moment (kip-ft)	Shear (kip)	Moment	Shear
C2, AZ 42-700N (Case 1)	405.3	32.1	1.5	391	650	1.04	0.05
C4, AZ 36-700N (Case 1)	270.4	26.6	1.1	334	520	0.81	0.05
C4, AZ 36-700N (Case 2)	376.2	36.7	2.1	334	520	1.13	0.07

The results in Table 6.1 show overstress in the sheet piles at Cross-Section C2 for impact with a ballasted barge at 3.8 ft/s. Impact forces are directly proportional to the impact velocity squared. Therefore, the stresses in Cross-Section C2 will be lower for impact at 1.8 ft/s as the impact force will reduce by 27%.

The results in Table 6.2 show that the stresses in the section exceed the elastic yield stress limit for moment demands. This is indicative of permanent deformation and damage condition in the form of excessive bending or bowing and local buckling of the sheet piles. The excessive stresses were limited to the localized area where impact load was applied. The sheet piles will require repair or replacement in such instances.

The Cross-Sections closer to the navigational waterway would be expected to potentially encounter impact with barges, ballasted or laden, as they are towed. It should be noted that the barges and tugboats typically slow down as the width of the navigational waterway reduces closer to the I-10 Bridge. Navigational signs can be posted on the exterior face of the BMP to require marine vessels to reduce speeds along the eastern side of the BMP.

Additional details of the analyses, results, and plots are provided in Attachment 3.

## 6.8 Pile Driveability and Vibration Analysis

During the March 25, 2020, TWG Meeting, the design team was asked to perform an evaluation to quantify the risks associated with pile driving-induced vibrations and potential releases from the Northern Impoundment that may result from these vibrations. A vibration analysis for driving large diameter steel pipe piles into deep sands was performed and included in the 30% RD. Since the submittal of the 30% RD, the BMP concept has changed from cantilever (large diameter pipe piles) to a double wall system with Z-shaped steel sheet piles. The alignment of the BMP has been revised to install the sheet piles outside the perimeter of the TCRA armored cap and beyond the edges of the steep slopes present near both the northwest corner and east side adjacent to the I-10 Bridge.

The Z-shaped sheet piles will be installed using a press-in method of installation. The first few pairs of sheet piles need to be installed using the vibratory hammer to set up the press-in equipment. Then a reaction-based press-in system will use these installed sheet piles to press-in the next pair of sheet piles and move forward to continue installing the remaining length of the BMP using the press-in method. As the press-in piling system uses hydraulic

force without the use of percussion (impact hammer) or vibration to install piles, the noise and vibration impact on nearby structures can be diminished. The sheet piles will also be terminated in the Beaumont Clay layer instead of driving into the stiffer sand layers, thereby reducing the potential for vibrations significantly even while using the vibratory hammer for the initial set of sheet piles.

Pile driveability and vibrations resulting from the installation procedure are a function of the equipment selected by the Contractor implementing the RA. Since information on actual equipment is unavailable at this time, pile driveability and corresponding vibrations were evaluated for one impact hammer and one vibratory hammer. The Wave Equation Analysis of Pile Driving (WEAP) showed that both equipment types can install the sheet piles to required depth. WEAP output for PACO Model 36-5000 (impact hammer) and APE Model 100 (vibratory hammer) are provided in Attachment 3.

Caltrans<sup>4</sup> provides guidance on calculating vibration amplitudes in terms of peak particle velocity (PPV) and threshold criteria for damage potential for various type of pile installation equipment. The equations used in the manual are based on several data points collected at various distances from the location of pile installation and for various installation equipment.

For Impact Hammers,

$$PPV_{Impact} = PPV_{Ref} (25/D)^n (E_{Equip}/E_{Ref})^{0.5}$$

Where:

$PPV_{Impact}$  = Vibration amplitude for the pile installation equipment at distance D from the location of installation.

$PPV_{Ref}$  = Vibration amplitude for a reference impact hammer at 25 ft from the location of installation (0.65 in/sec).

D = Distance from pile installation equipment to the receiver in ft.

n = Constant related to the vibration attenuation rate through ground (maximum suggested value of 1.4).

$E_{Ref}$  = Rated energy of the reference pile installation equipment (36,000 ft-lb).

$E_{Equip}$  = Rated energy of the impact hammer to be used for pile installation (PACO Model 36-5000: 15,000 ft-lb).

For Vibratory Hammers,

$$PPV_{Vibro} = PPV_{Ref} (25/D)^n$$

Where:

$PPV_{Vibro}$  = Vibration amplitude for the pile installation equipment at distance D from the location of installation.

$PPV_{Ref}$  = Vibration amplitude for a reference impact hammer at 25 ft from the location of installation (0.65 in/sec).

D = Distance from pile installation equipment to the receiver in ft.

n = Constant related to the vibration attenuation rate through ground (maximum suggested value of 1.4).

The calculated PPV for the impact and vibratory hammer are shown in Figure 6.13. The threshold for damage to new residential structures, modern industrial or commercial building type structures due to vibrations from continuous or frequent intermittent sources such as the pile installation procedure is 0.5 in/sec (Table 19<sup>4</sup>). This threshold is considered appropriate for the structures near the BMP, including the I-10 Bridge. The anticipated vibration from the vibratory hammer is below the acceptable threshold at 35 ft or farther from the sheet pile installation. The vibration

<sup>4</sup> Transportation and Construction Vibration Guidance Manual, April 2020, California Department of Transportation

reduces significantly with the distance. The contractor will be allowed to use a vibratory hammer or impact hammer only for the initial setup of sheet piles and the press-in equipment and at least 35 ft away from the I-10 bridge. Thus, no significant impact to the I-10 bridge or other industrial structures is anticipated due to the sheet pile installation.

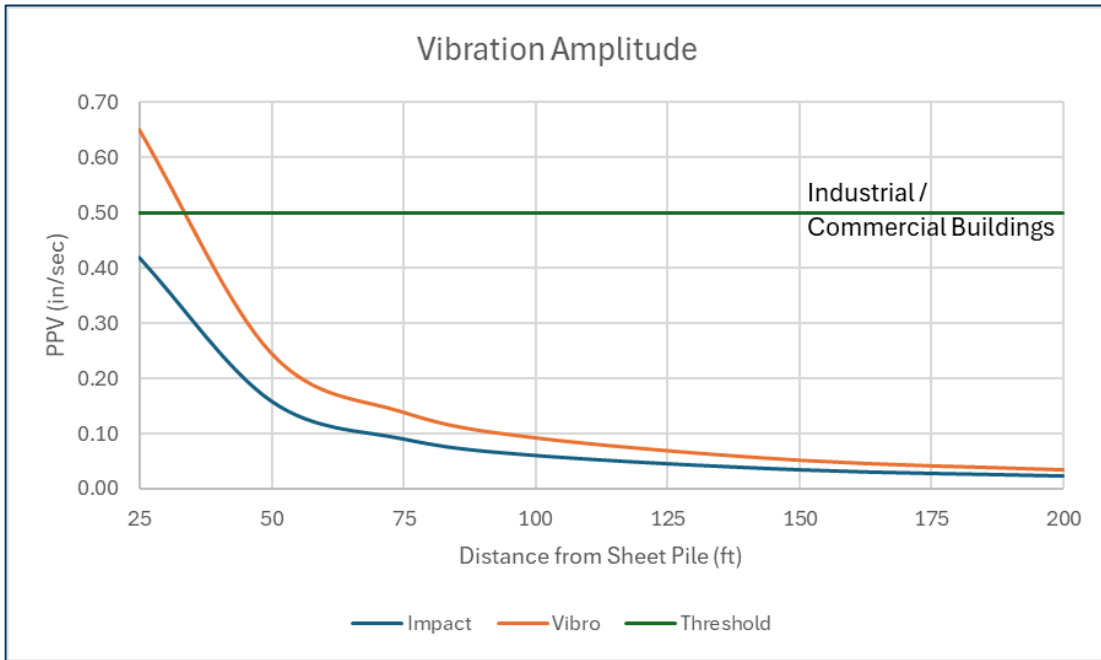

Figure 6.13 Vibration Amplitude (PPV) for Pile Installation Equipment

The Contractor implementing the RA will be required to update the pile driveability and vibration analysis for the equipment to be used during the RA and for allowed use of a vibratory hammer at a minimum distance of 35 ft from the nearest structures.

## 6.9 Seepage through Sheet Piles

The BMP is considered a temporary structure and is planned to be removed after the RA is complete. The steel sheet piles, except for the interlocks, are completely impervious. The seepage or discharge through the sheet pile interlocks is proportional to the pressure drop across the interlocks in a horizontal plane. The vertical flow through the interlocks is negligible as the sheet piles will be terminated in the Beaumont Clay Formation and hence, no seepage is expected from under and/or around the sheet piles.

Figure 6.14 shows a general relationship<sup>5</sup> of discharge through interlocks and the pressure-drop across the sheet piles for the following three conditions. The example highlighted in the figure compares the anticipated seepage through the interlocks for the same pressure-drop for each of the three conditions:

1. Standard Interlocks, no sealant, or welds.  
Interlocks filled with plugged soil during sheet pile installation.  
Interlocks filled with filler material or sealants.

Compared to the standard interlocks, the interlocks plugged with soils during pile installation reduce the seepage to 70 percent. The interlocks filled with the proprietary sealant material allowed 25 percent seepage during tests. However, at the maximum tested pressure-drop (approximately 100 kPa, or 30 ft of standing water), the three interlock conditions allowed the same volume of seepage.

<sup>5</sup> Arcelor Mittal, Impervious Steel Sheet Pile Walls, Design & Practical Approach.

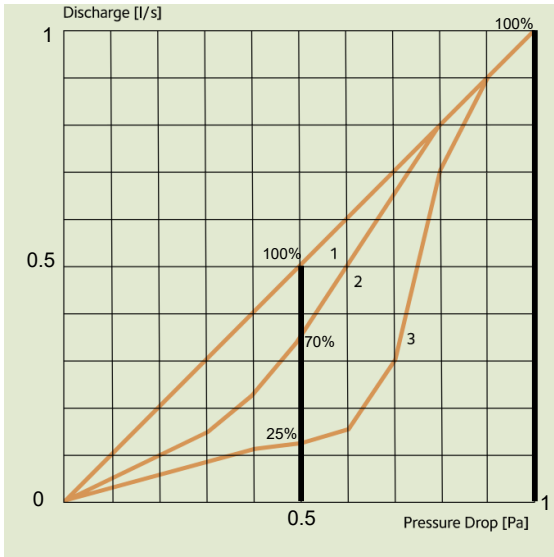

Figure 6.14 Discharge - Pressure Drop Relationship, Arcelor Mittal

It is anticipated that the soft sediments will plug the interlocks of the sheet pile during installation. The fill material between the walls of the BMP will also create a pressure-gradient instead of an abrupt pressure-drop across the exterior sheet pile wall of the BMP. In addition, the two sets of interlocks (exterior and interior wall) at any vertical cross-section will minimize the potential of seepage through the BMP.

During normal operations (that is, other than during flooding during heavy rain or storms), it should be possible to manage any seepage from the river into the excavation area as part of the waste removal process. If the excavation area is flooded due to a heavy rain or storm, the pressure-drop between the exterior and interior side of the BMP will reduce and the resultant pressure-drop will still only allow seepage toward the interior of the BMP.

An interlock sealant WADIT is specified for the inner walls of the BMP.

The seepage from under the BMP into the excavation area is calculated using Lane's Weighted Creep Ratio. The Cross-Section C2 from the northwest portion of the BMP was evaluated with river water at top of the exterior wall (water at elevation +10 ft). This condition represents the largest head differential (available head) when the water in the Northern Impoundment is lowered to mudline. The calculations show that the seepage (or piping) potential from under the wall into the excavation area is insignificant. At other locations of the wall along the BMP, the available head will be lower as the mudline is shallower than Cross-Section C2 and is dissipated in the soil layers similar to Cross-Section C2.

The seepage calculations are provided in Attachment 3.

## 6.10 Design Summary

The summary of the structural design for the various representative sections analyzed is provided in Table 6.3. The tie-rod spacing shown in the summary includes closer spacing than the spacing used in the analysis to incorporate an additional safety factor against potential progressive failure described in Section 5.2.3. The closely spaced tie-rods increase the stiffness of the system, and the overall stresses and deflection in the BMP are expected to improve.

**Table 6.3** Summary of BMP Design

Analysis Section	Sheet Pile Section		Tie Rod Section		Waler Section
	Nucor Skyline	Length (ft)	Diameter (inches)	Spacing (ft)	
C1, C3, C3A, C4, C4A	AZ36-700N	50	2.25	5	MC 12X35
C2	AZ40-700N	55	3.00	5	MC 18X45.8
C5	AZ36-700N	60	2.25	5	MC 12X35
C6, C7	AZ26-700	60	2.25	5	MC 12X35

### 6.10.1 Analysis Notes

1. As the site conditions for Cross-Sections C3 and C3A overlap, it is recommended that the construction stages for Cross-Section C3 be followed for both as a conservative approach.
2. There is potential for the sheet piles to deflect towards the river during installation or placement of fill material before the tie-rods are installed. The sheet piles may need to be temporarily braced during placement of fill material and tie-rod installation.
3. Cross-Sections C6 and C7 should maintain a Soil Buttress from face of the BMP to the excavation area, sloping at 3H:1V. The minimum elevation at the top of the Soil Buttress should be 0 ft NAVD88.
4. For the purposes of the analyses, the water level in the fill material between the two sheet pile walls is assumed to be at the same level as the river. This assumption is conservative. The water levels between the two sheet piles may not coincide with the water levels in San Jacinto River. Lower water levels or dry fill between the sheet piles will result in lower deflections and stresses in the sheet piles and tie-rods.

## 7. Other Considerations

The BMP design presented in this Third Final 100% RD submission provides an implementable solution for the design parameters and design criteria described in Sections 3 and 5, respectively. There are other considerations that may impact the constructability of the BMP and in turn affect the RA, as described below.

### 7.1 Foundation Substructure of I-10 Bridge

As discussed above in Section 6.2.7, the BMP along the southern alignment is on the TxDOT ROW and close to I-10. From the record drawings received from TXDOT, the pile abutment for the westbound bridge nearest to the southern alignment of the BMP are Bents #24 through #27. The foundation of Bent #26 and #27 use batter piles, with batter in the east-west direction within the footprint of the bridge. Therefore, the BMP alignment does not clash with the foundation.

It is understood that TXDOT will continue to be engaged with the project team and will review the design for potential impacts to their future bridge construction.

### 7.2 Underground Utilities

As discussed above in Section 6.2.7, the BMP along the southern alignment is on the TxDOT and close to the I-10 Bridge. The sheet piles will be installed using the press-in system and the construction procedure is not anticipated to generate significant vibrations to impact any structures nearby.

It is understood that the owners of the underground utilities will continue to be engaged with the project team and will review the design for potential impacts to their assets.

## 7.3 Slope Stability

Stability of excavated and open slopes was evaluated for the following two height differentials –

Slope from elevation -3 ft to elevation -15 ft (height = 12 ft)

Slope from elevation -13 ft to elevation -20 ft (height of 7 ft)

The range of excavation and open slopes represent different areas within the Northern Impoundment. The slopes ranging from 1V:2.5H to 1V:3H resulted in a factor of safety greater than 1.50.

The outputs for slope stability analyses are provided in Attachment 4.

# Attachments

# **Attachment 1**

## **Geotechnical Parameters and Data Profiles**



Client IPC and MIMC Job Number 11215702 Sheet \_\_\_\_\_  
Project San Jacinto River Waste Pits Site Sheets By S.Chilka Date 07-11-2024  
Subject BMP Design - Geotechnical Parameters Checked By \_\_\_\_\_ Date \_\_\_\_\_

APPENDIX I - BMP STRUCTURAL DESIGN REPORT  
**ATTACHMENT 1**  
**GEOTECHNICAL PARAMETERS**

# ENCLOSURE 1.A

# Atterberg Limits and Moisture Content

## Wet Bulk Unit Weight

## Blow Counts (N-Values)

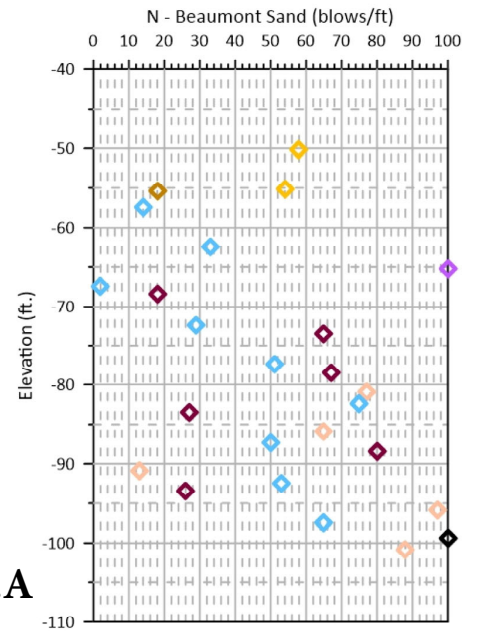
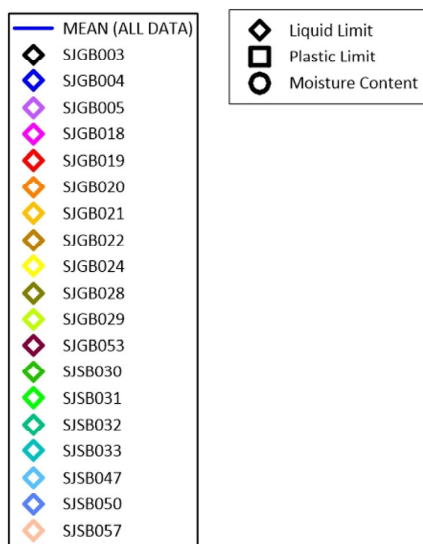
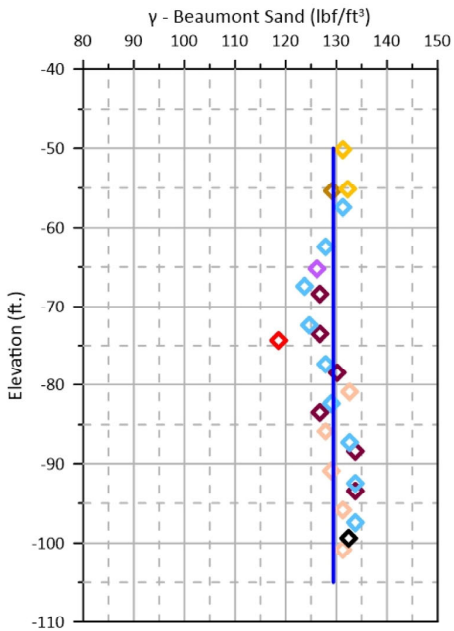
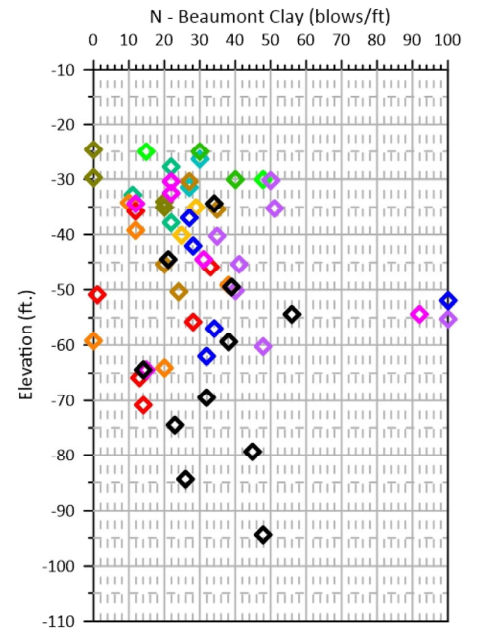
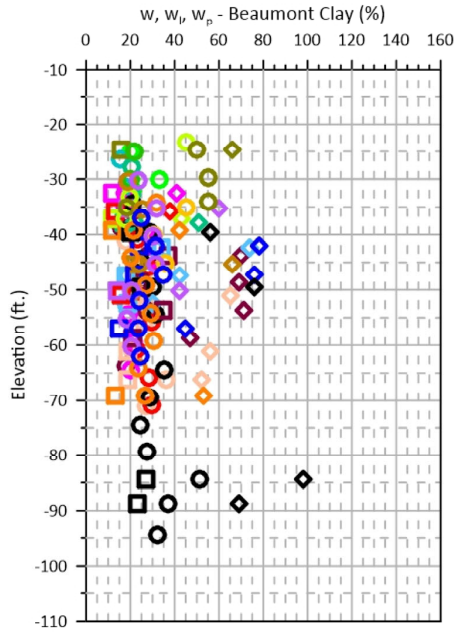
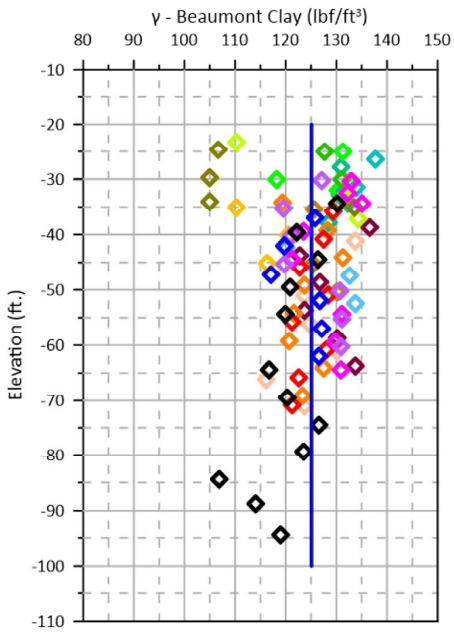
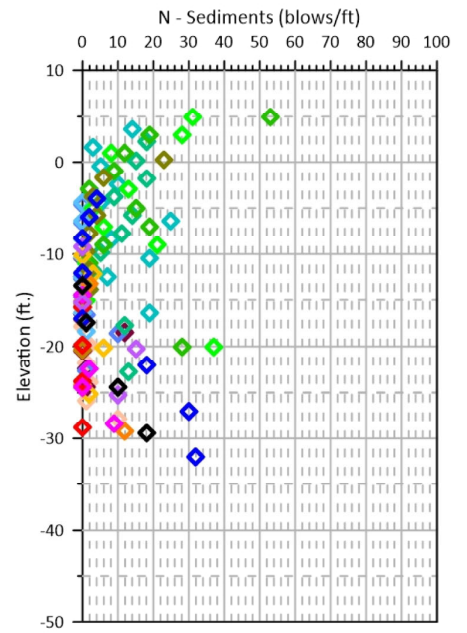
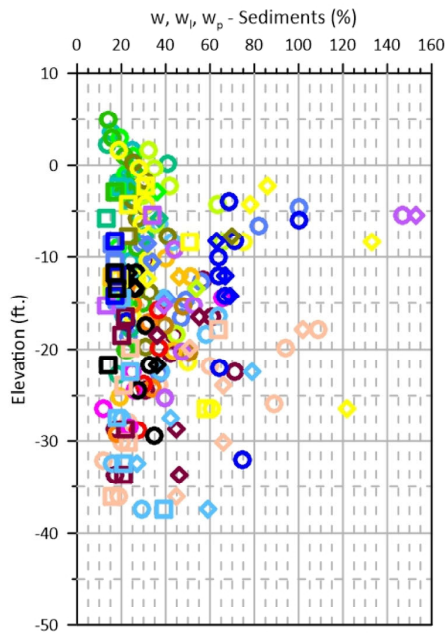
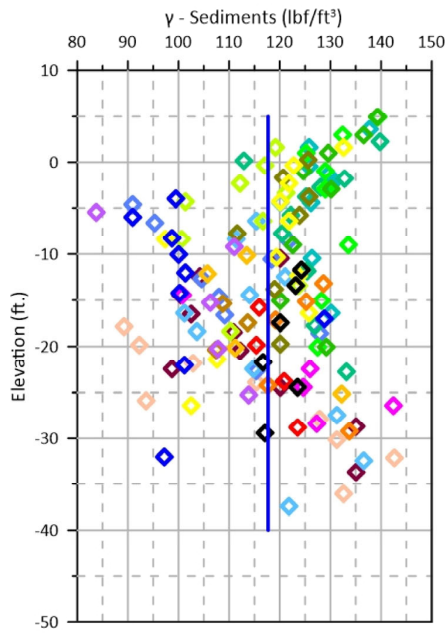

**Enclosure 1.A**

# ENCLOSURE 2.A

# Enclosure 2.A1

## Su - Alluvium Sediments - CPT-01 to CPT-04

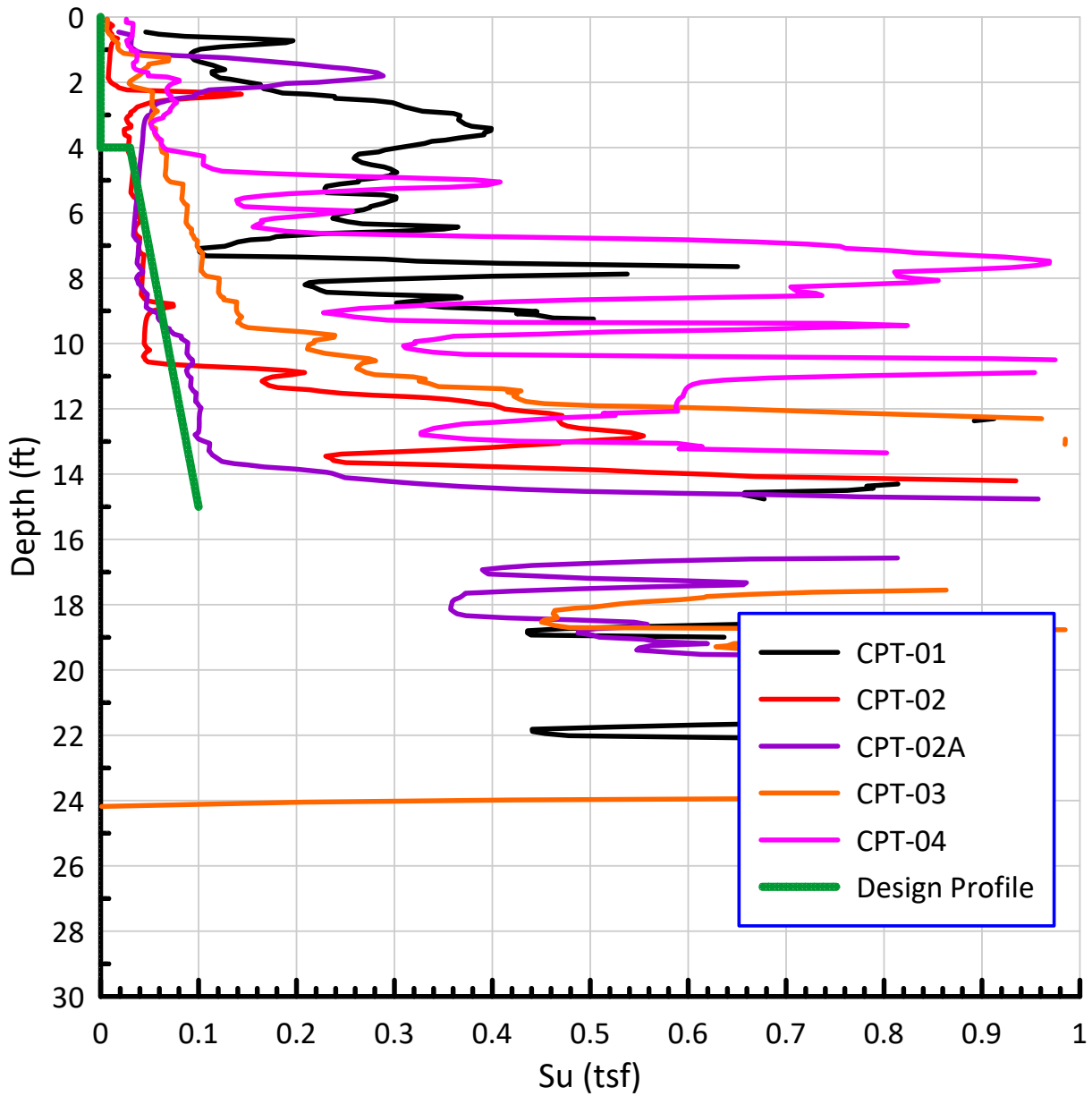

San Jacinto River Waste Pit  
Northern Impoundment remedial Design  
GHD Project No 11215702

# Enclosure 2.A2

## Su - Alluvium Sediments - CPT-04 - CPT-06

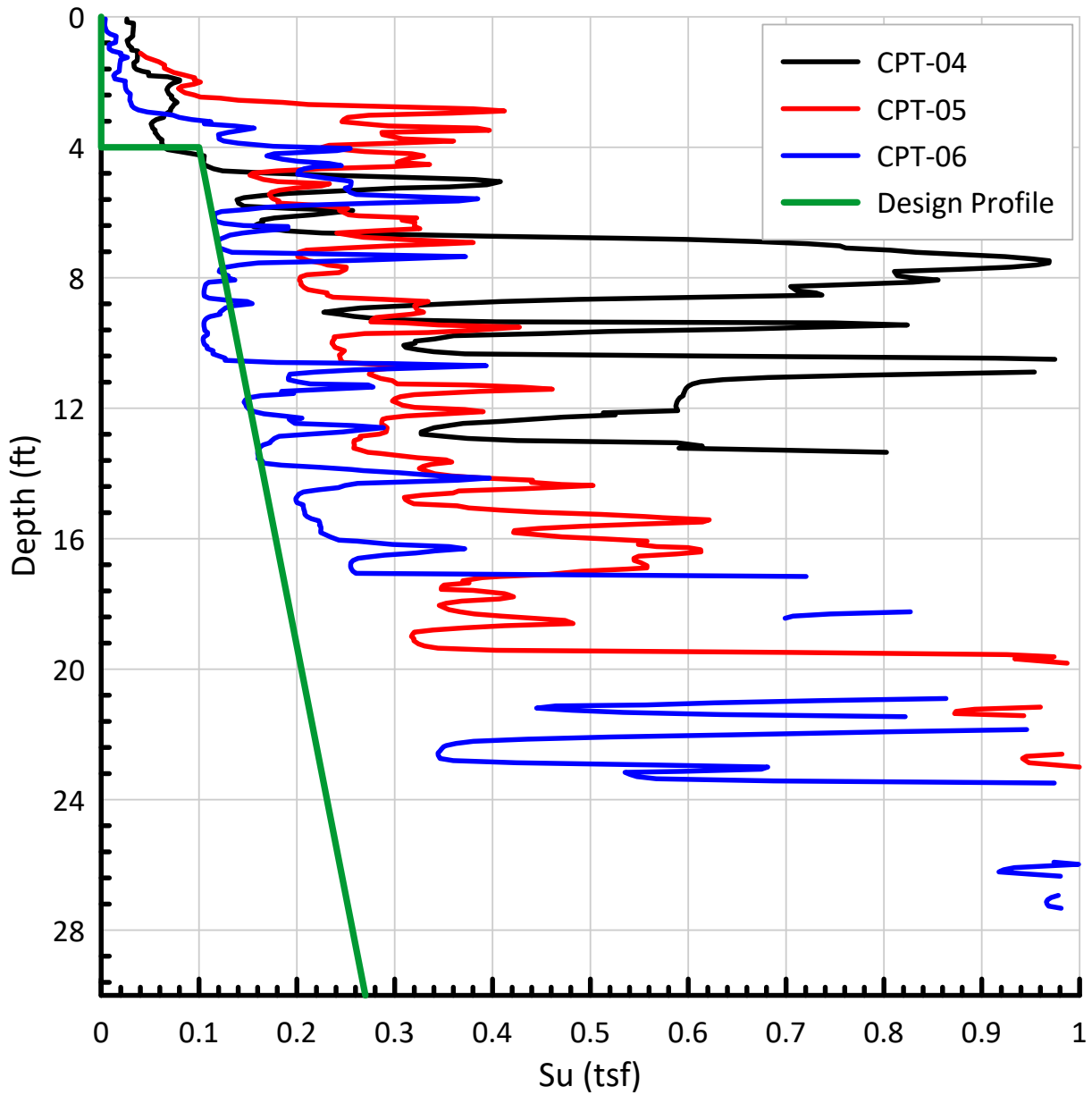

San Jacinto River Waste Pit  
Northern Impoundment remedial Design  
GHD Project No 11215702

# Enclosure 2.A3

## Su - Alluvium Sediment - CPT-06 - CPT-10

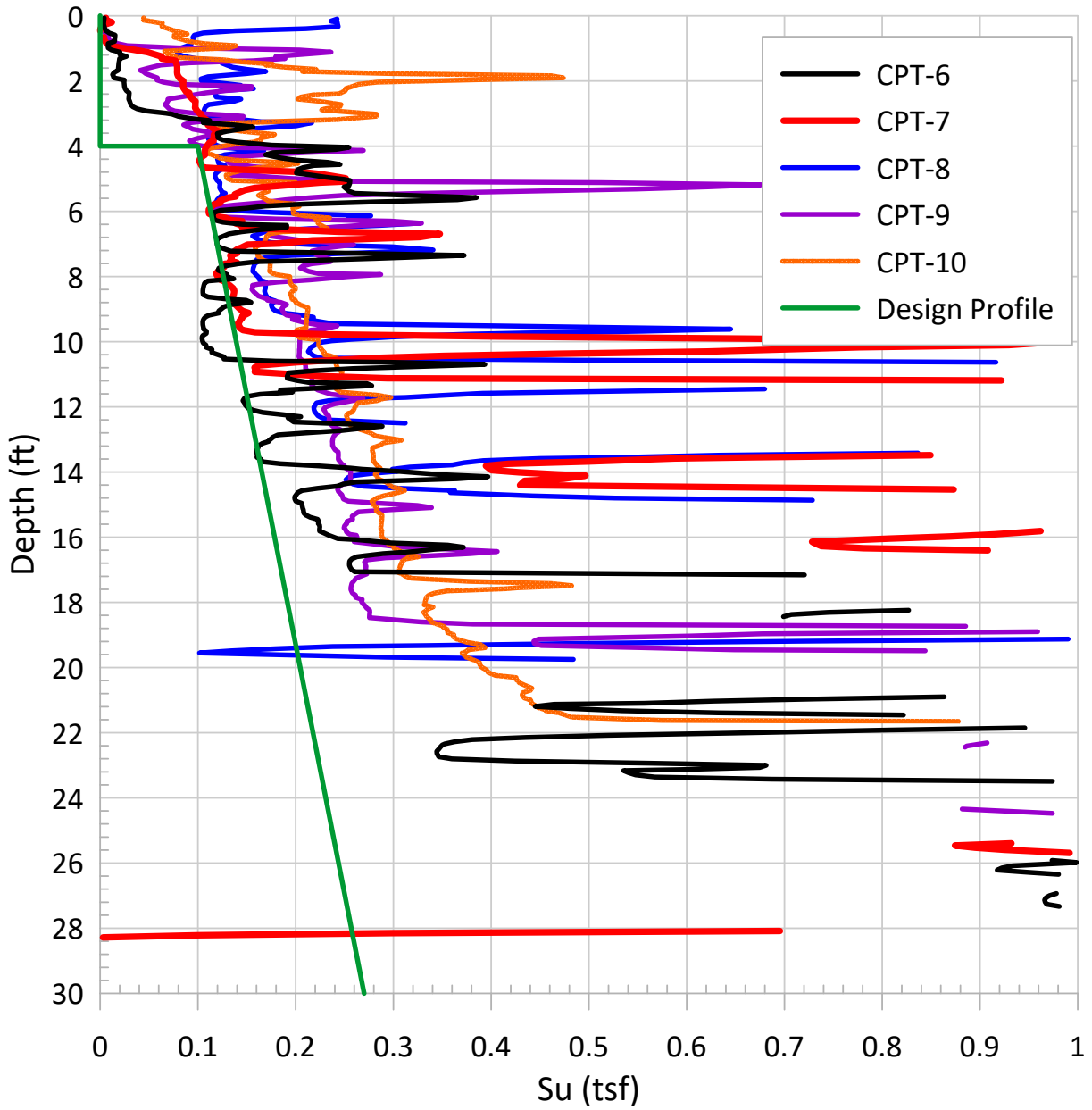

San Jacinto River Waste Pit  
Northern Impoundment remedial Design  
GHD Project No 11215702

# ENCLOSURE 2.B

## Enclosure 2.B

### Su Design Profile - Beaumont Clay

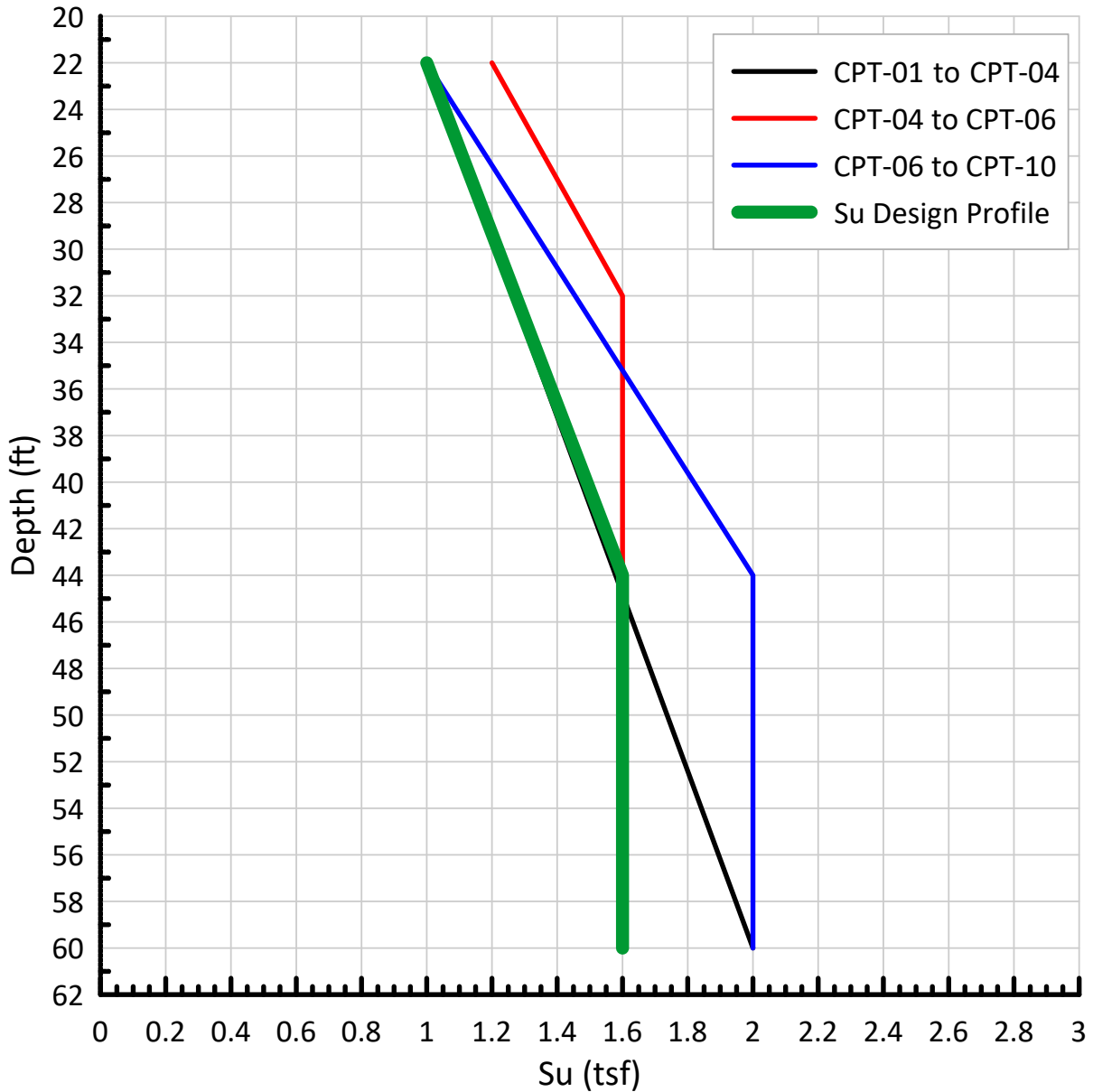

San Jacinto River Waste Pit  
Northern Impoundment Remedial Design  
GHD Project No 11215702

# ENCLOSURE 3.A

# Enclosure 3.A

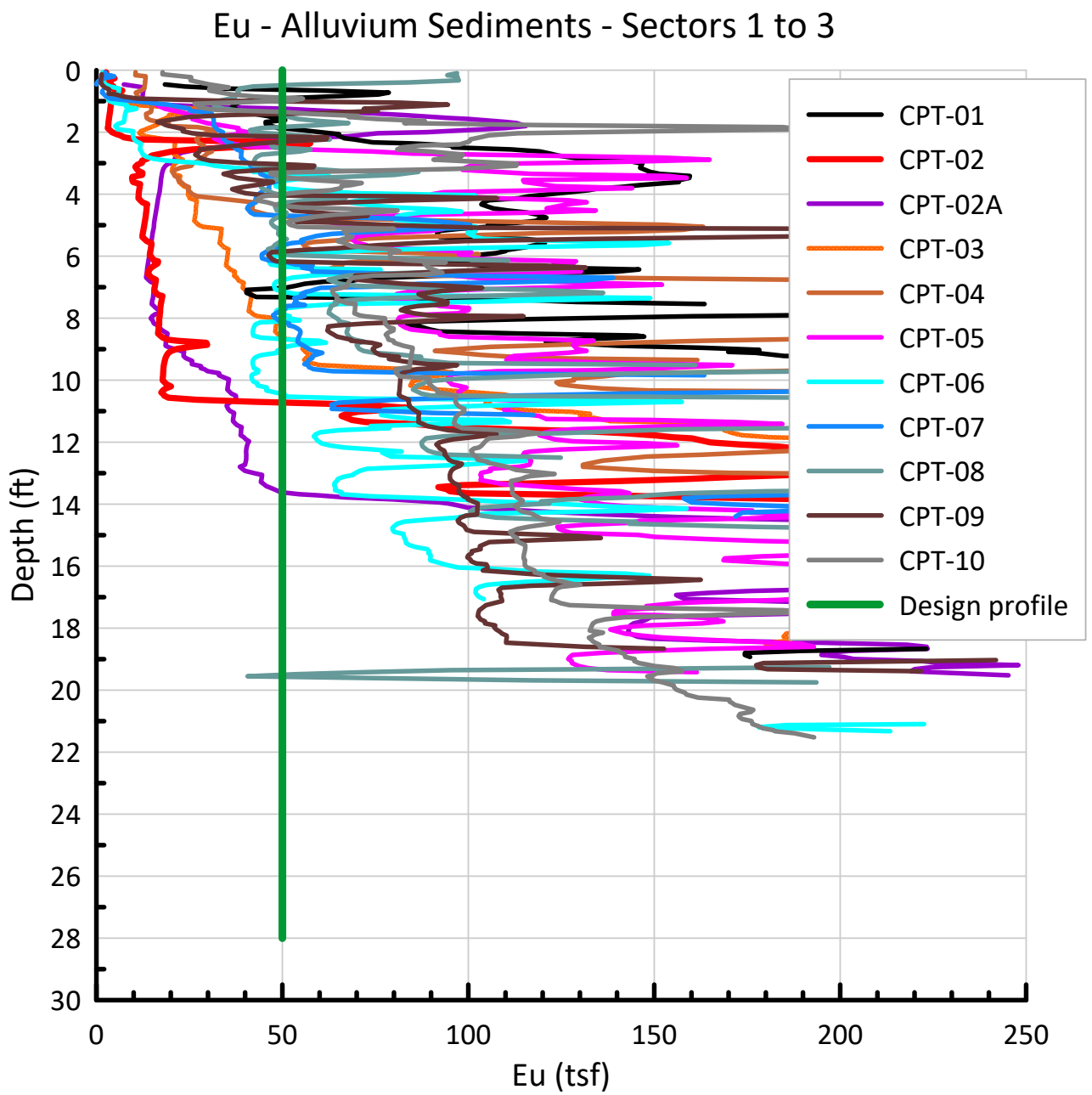

# ENCLOSURE 3.B

# Enclosure 3.B

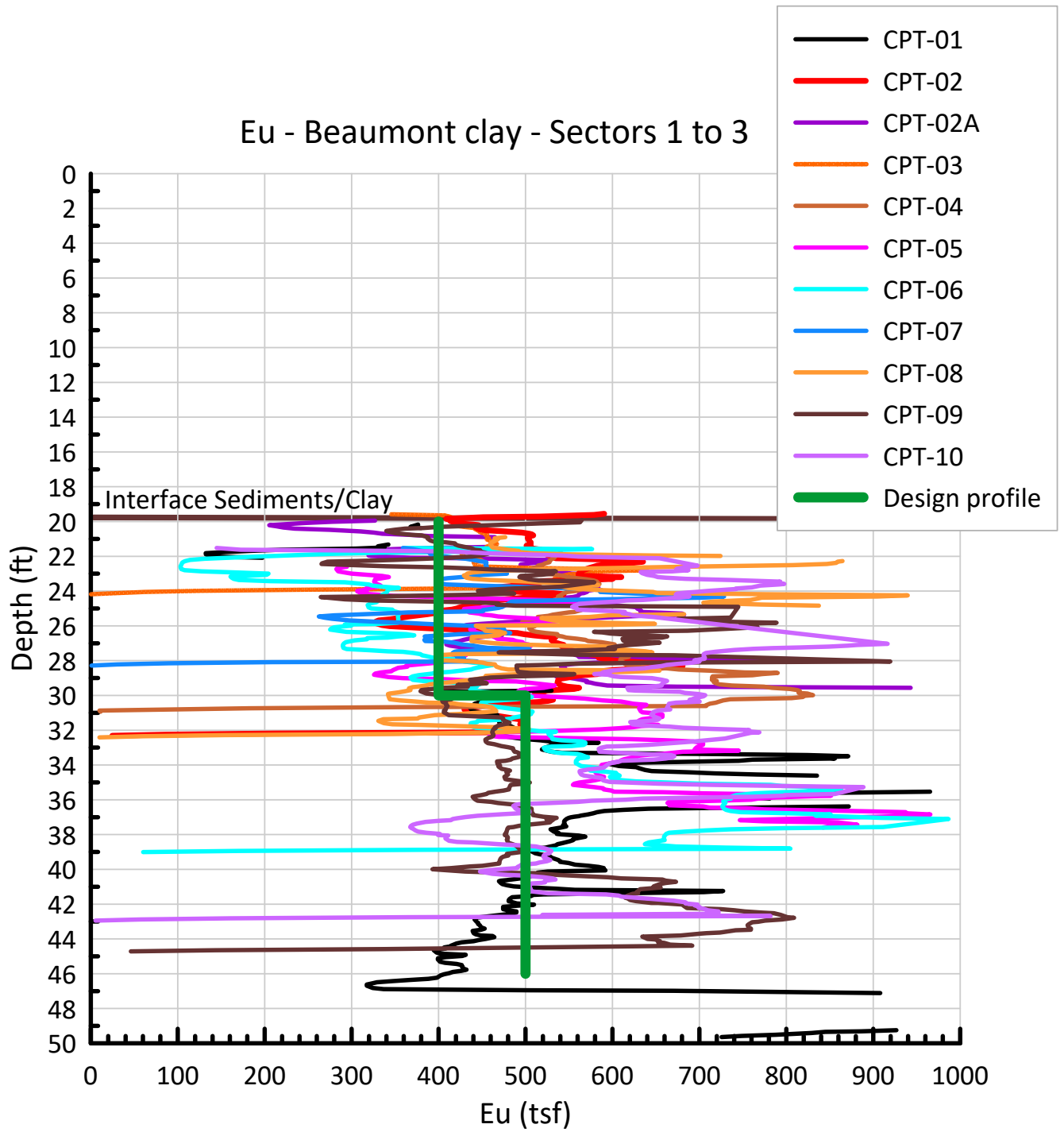

# ENCLOSURE 3.C

# Enclosure 3.C

## Es - Beaumont Sand - Sectors 1 to 3

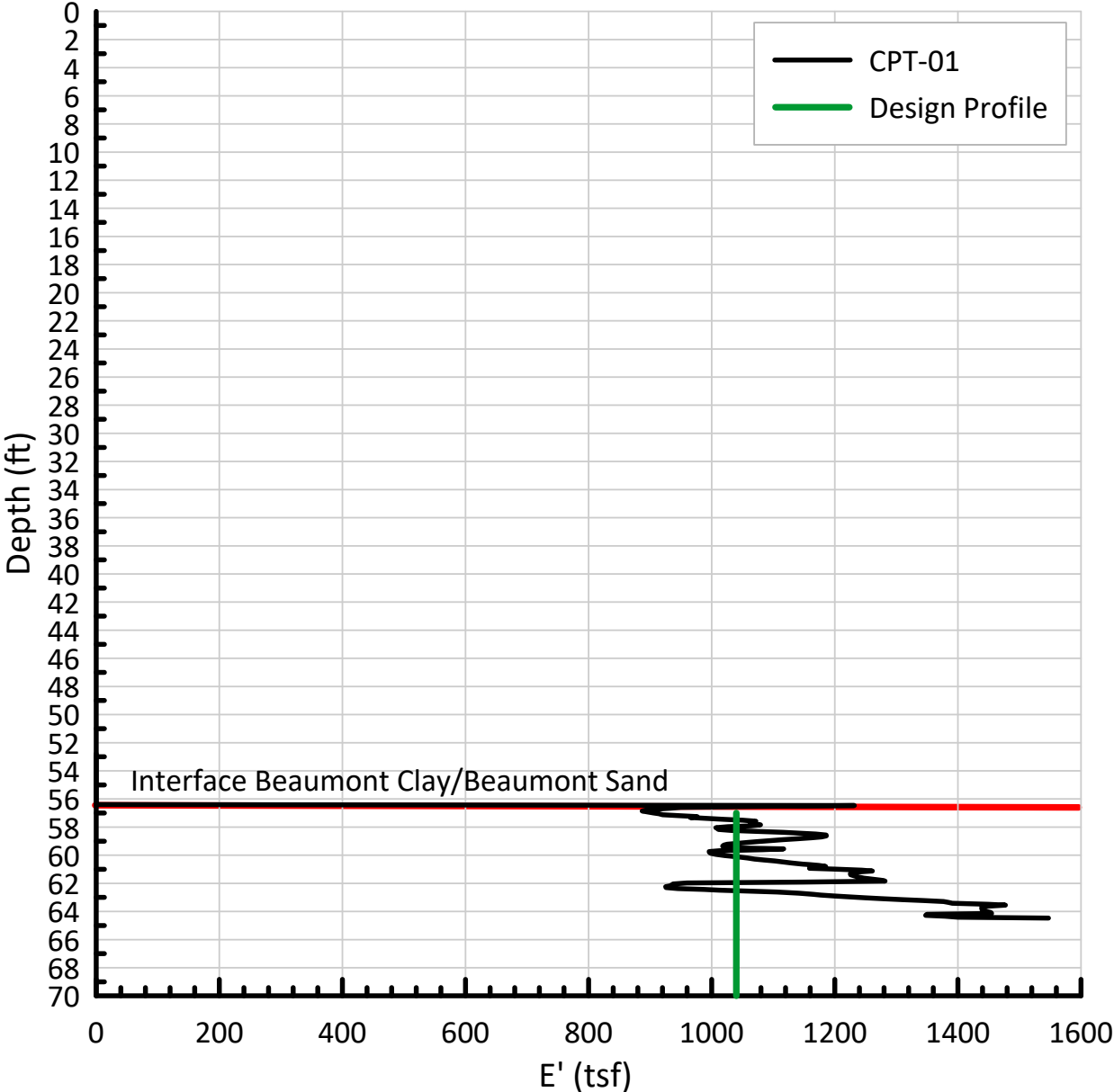

# ENCLOSURE 4.A

# Enclosure 4.A

## $\phi'$ (°) - Alluvium Sediments - Sectors 1 to 3

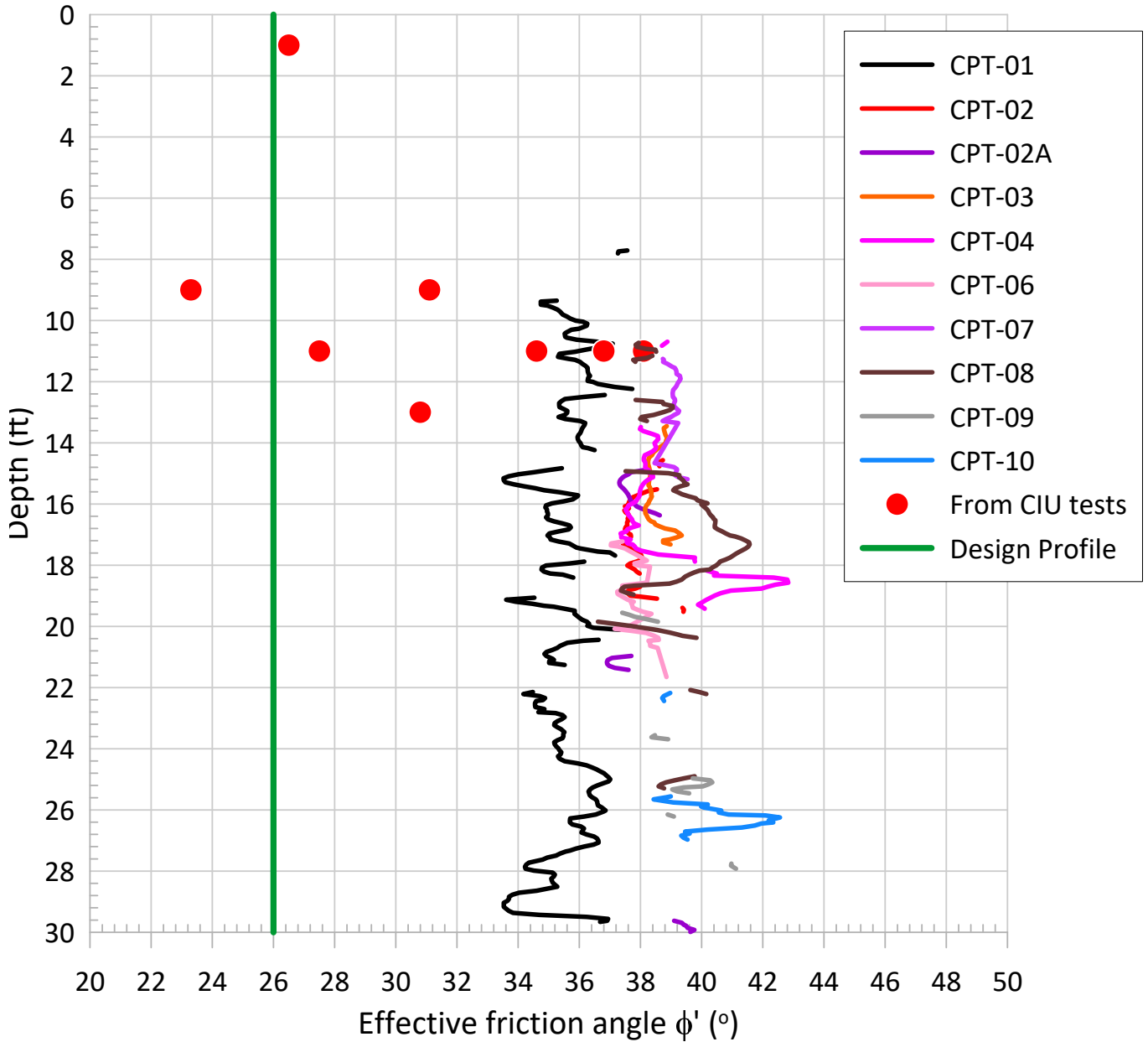

# ENCLOSURE 4.B

# Enclosure 4.B

## $\phi'$ (°) - Beaumont Clay - Sectors 1 to 3

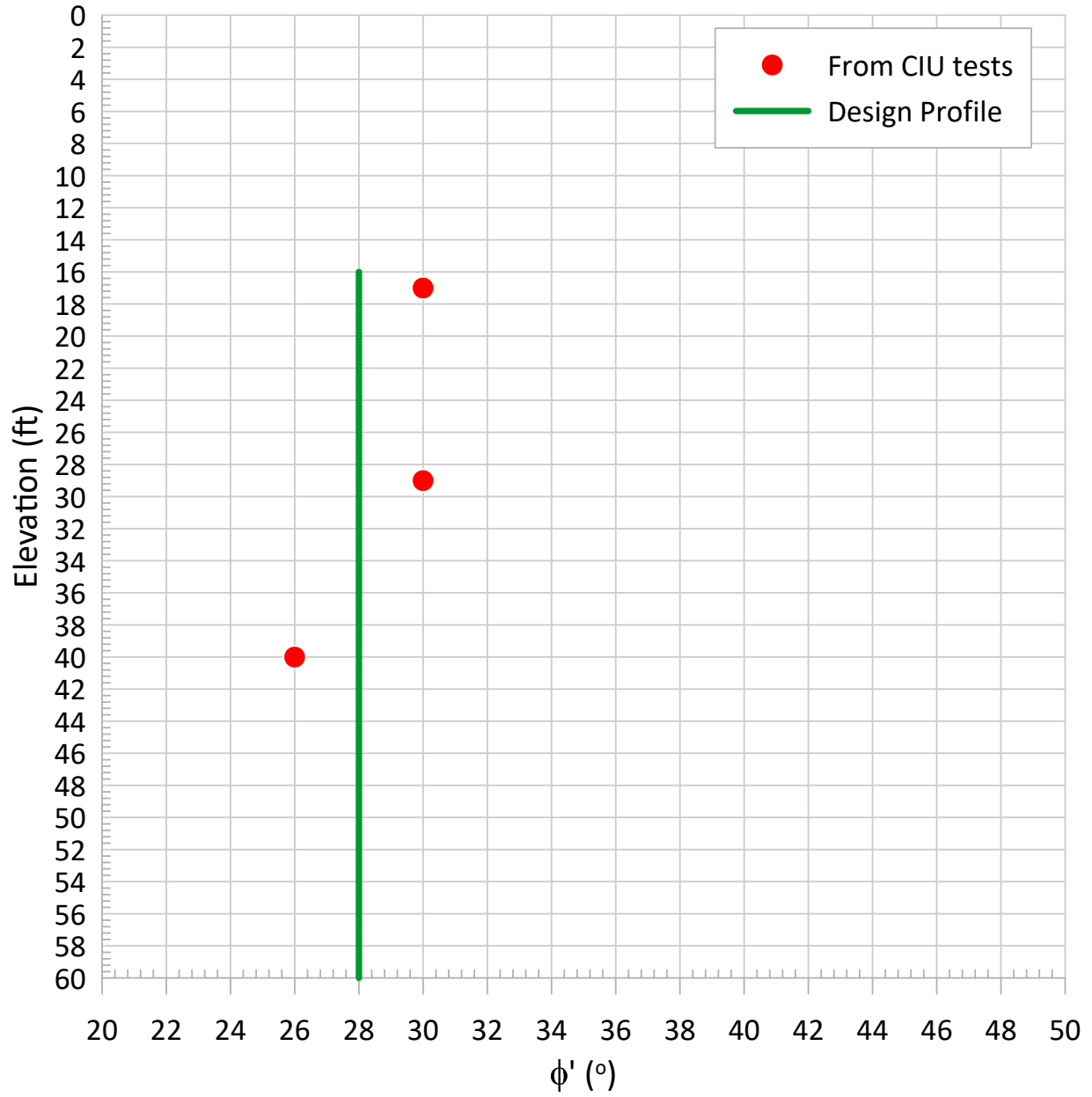

# ENCLOSURE 4.C

# Enclosure 4.C

$\phi'$  (°) - Beaumont Sand - Sector 1 to 3

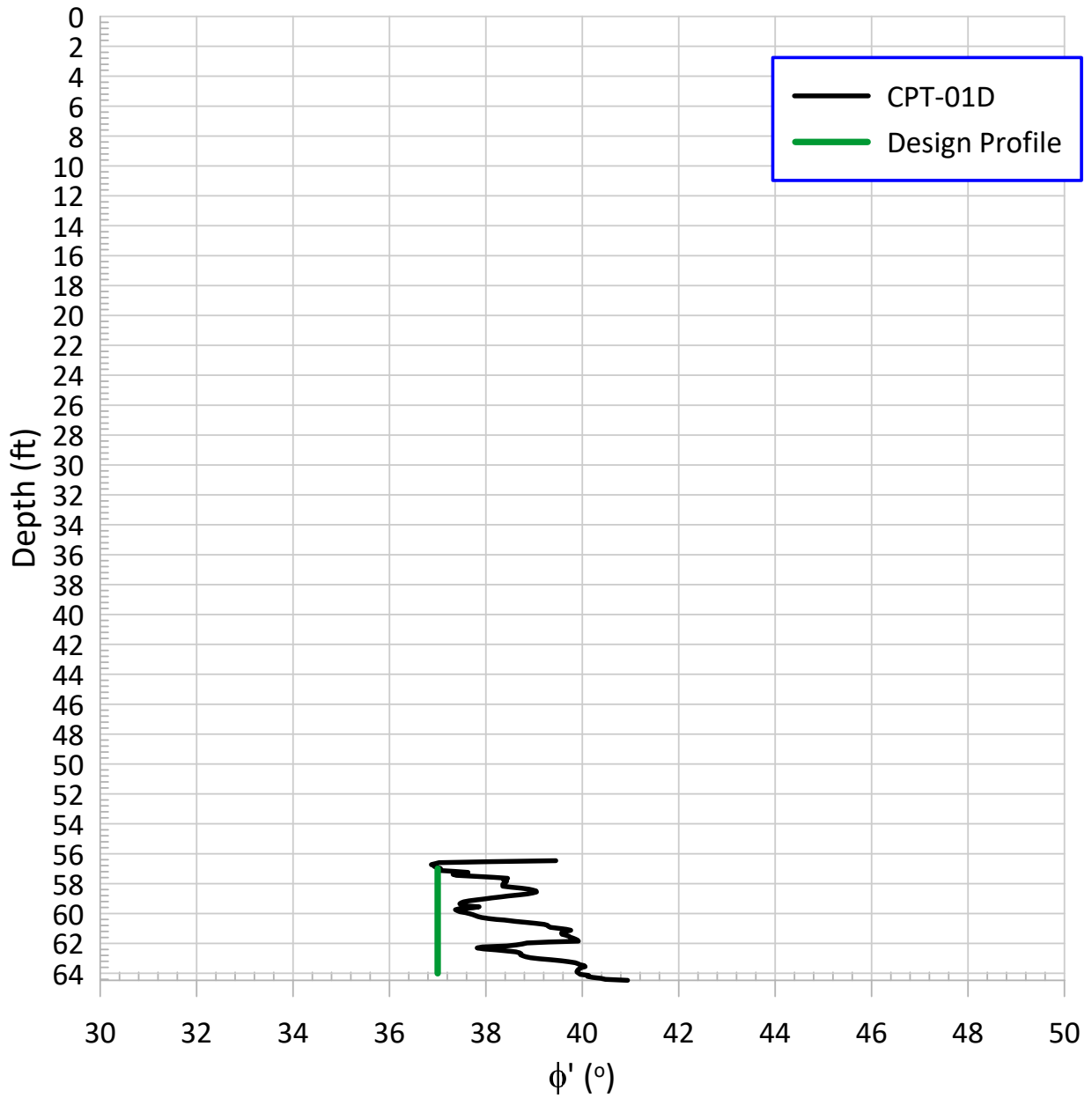

# ENCLOSURE 5.A

# Enclosure 5.A

## OCR - Beaumont clay - Sectors 1 to 3

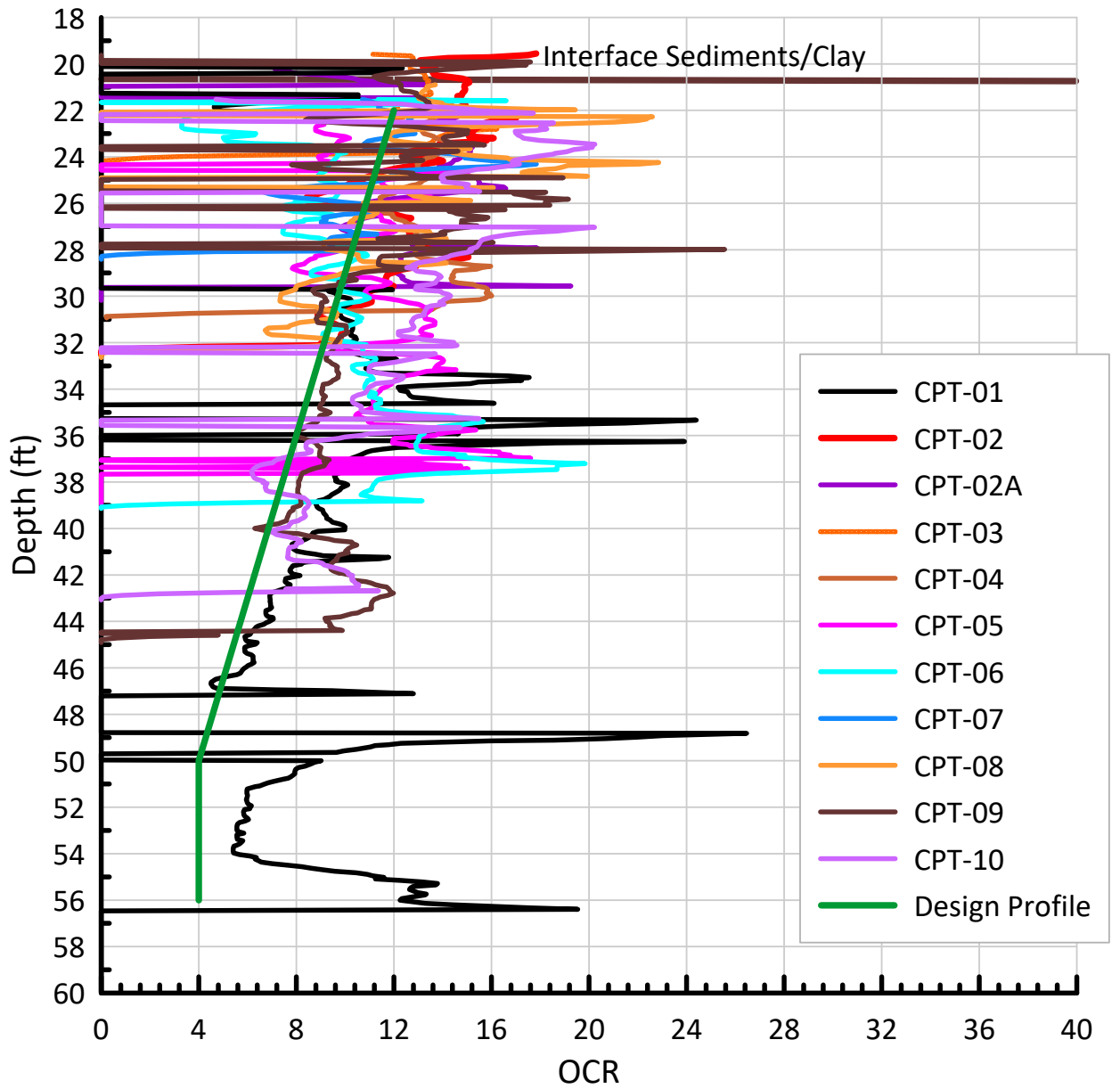

# ENCLOSURE 6.A

# Enclosure 6.A

## k - Alluvium Sediments and Beaumont Clay

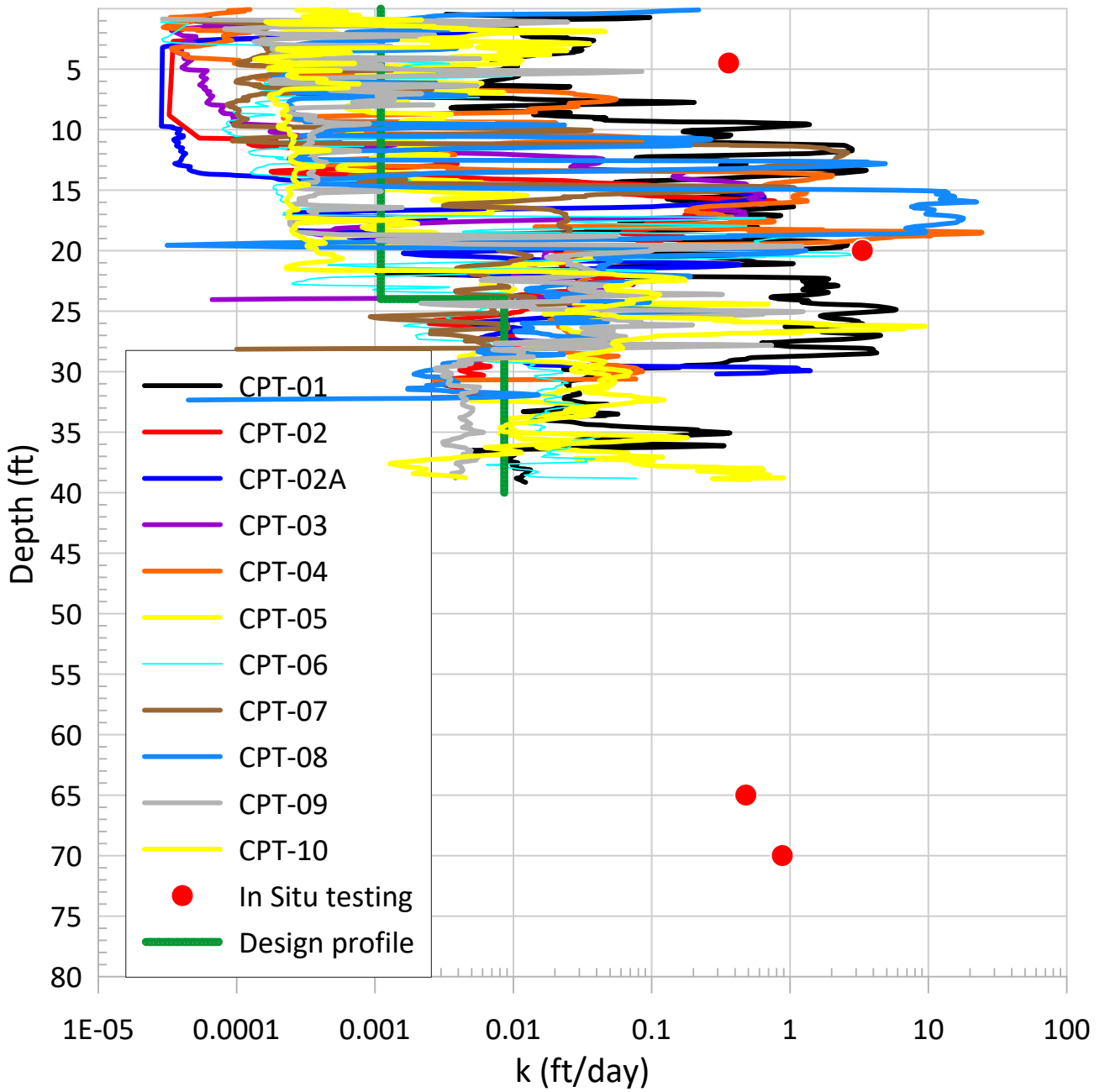

# Attachment 2

**BMP Analysis - PLAXIS Sections**



Client IPC and MIMC Job Number 11215702 Sheet \_\_\_\_\_  
Project San Jacinto River Waste Pits Site Sheets By S.Chilka Date 07-11-2024  
Subject BMP Design Checked By \_\_\_\_\_ Date \_\_\_\_\_

APPENDIX I - BMP STRUCTURAL DESIGN REPORT  
**ATTACHMENT 2**  
**PLAXIS ANALYSIS SECTIONS**



Client	IPC and MIMC	Job Number	11215702	Sheet	
Project	San Jacinto River Waste Pits Site	Sheets by	J. Jeyakanthan	Date	5/27/2022
Subject	Soil Parameters - PLAXIS Analysis	Checked by		Date	

Parameters		Units	Sediment Hardening Soil
Unsaturated unit weight	$\gamma_{unsat}$	lbf/ft <sup>3</sup>	95
Saturated unit weight	$\gamma_{sat}$	lbf/ft <sup>3</sup>	120
Secant stiffness in standard drained triaxial test	$E_{50}^{ref}$	lbf/ft <sup>2</sup>	105000
Tangent stiffness for primary oedometer loading	$E_{oed}^{ref}$	lbf/ft <sup>2</sup>	105000
Unloading / reloading stiffness	$E_{ur}^{ref}$	lbf/ft <sup>2</sup>	315000
Power for stress-level dependency of stiffness	power (m)		0.5
Effective cohesion	$c_{ref}$	lbf/ft <sup>2</sup>	42
Effective friction angle	$\phi$ (phi)	°	26
Saturated permeability - horizontal	$k_x$	ft/day	0.00113
Saturated permeability - vertical	$k_y$	ft/day	0.00113

Parameters		Units	Mohr-Coulomb			
			BCF	BSF	Fill	Rock fill
Unsaturated unit weight	$\gamma_{unsat}$	lbf/ft <sup>3</sup>	100	105	105	108
Saturated unit weight	$\gamma_{sat}$	lbf/ft <sup>3</sup>	125	130	130	130
Effective Young's modulus	E	lbf/ft <sup>2</sup>	8.60E+05	2.00E+06	300000	1044000
Effective Poisson's ratio	$\nu$ (nu)		0.3	0.3	0.3	0.3
Effective cohesion	$c_{ref}$	lbf/ft <sup>2</sup>	150	0	0	0
Effective friction angle	$\phi$ (phi)	°	28	37	32	38
Saturated permeability - horizontal	$k_x$	ft/day	8.50E-03	0.88	3	3
Saturated permeability - vertical	$k_y$	ft/day	8.50E-03	0.88	3	3

BCF = Beaumont Clay Formation  
 BSF = Beaumont Sand Formation

### Section C1 Soil Profile with BMP @ Analysis Stage 0 (Sheet Pile Installation)

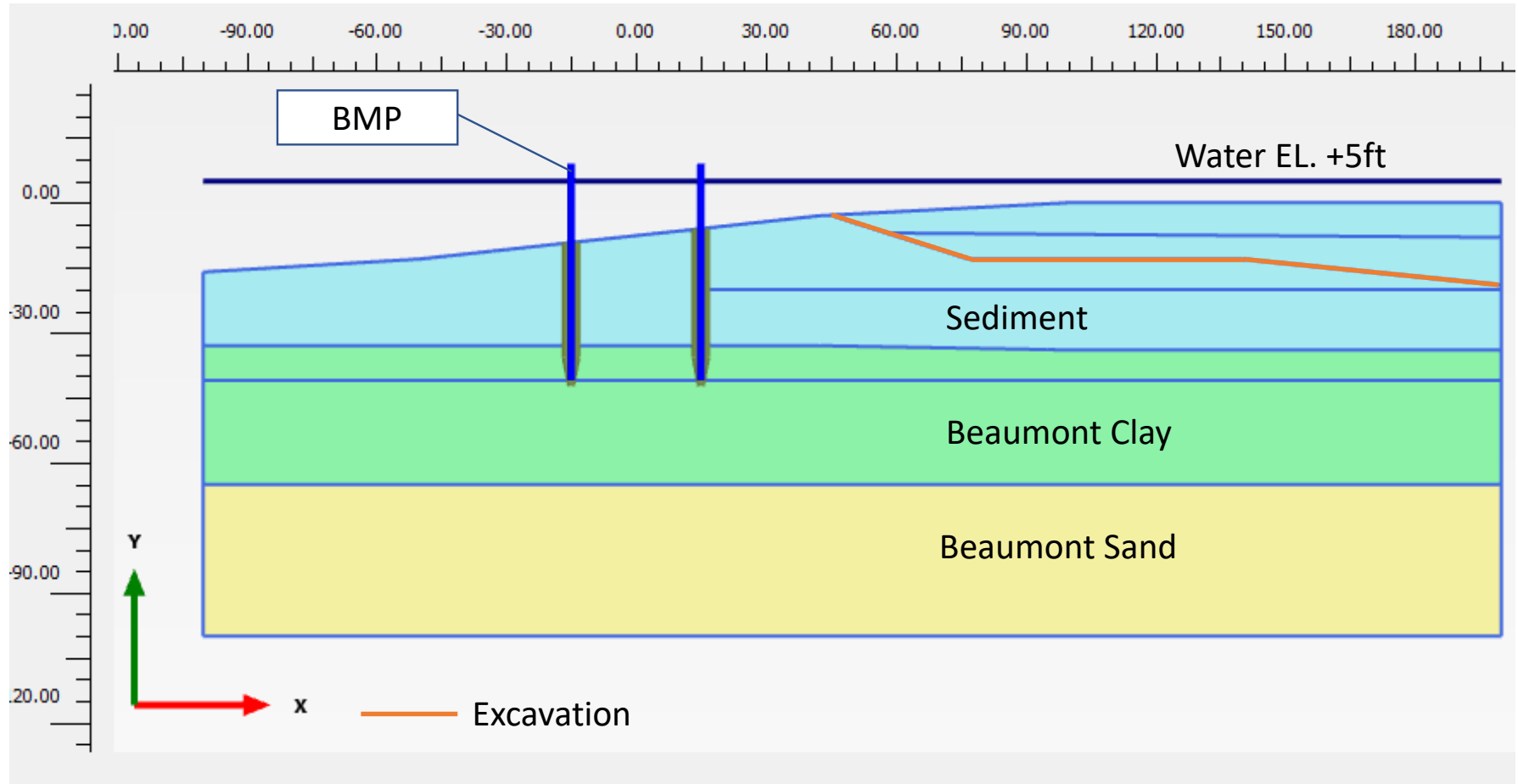

### Section C2 Soil Profile with BMP @ Analysis Stage 0 (Sheet Pile Installation)

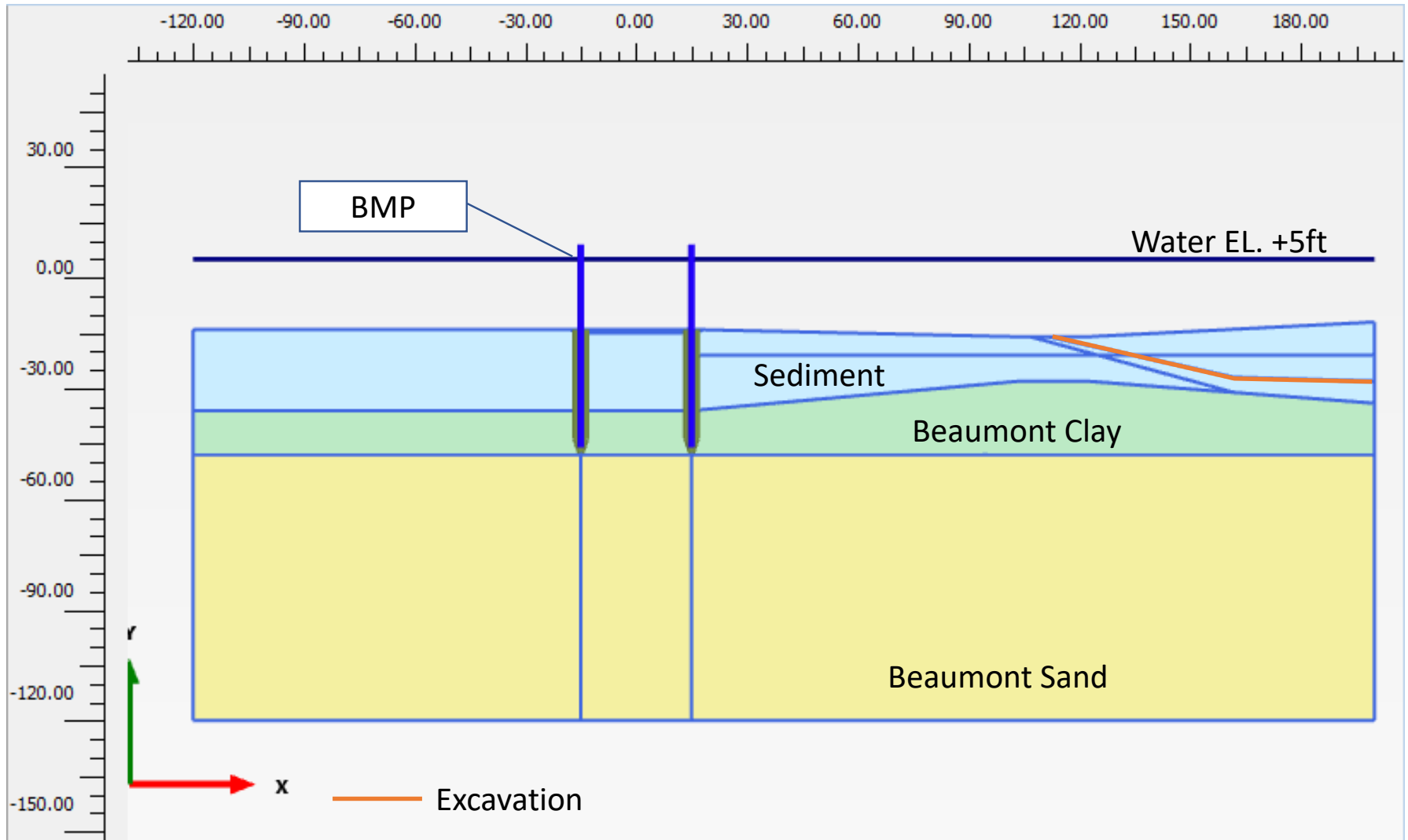

### Section C3 Soil Profile with BMP @ Analysis Stage 0 (Sheet Pile Installation)

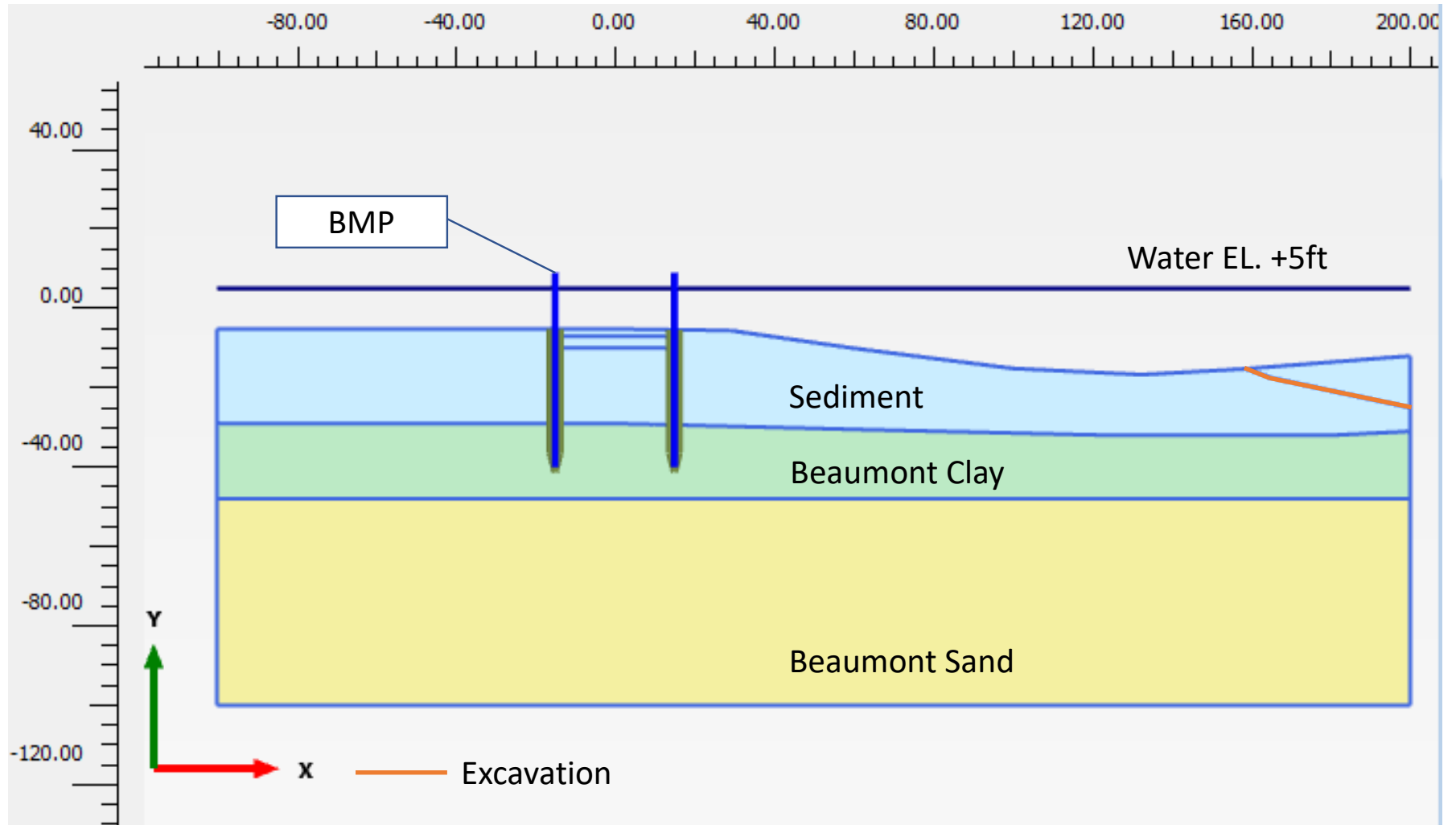

Section C3A Soil Profile with BMP @ Analysis Stage 0 (Sheet Pile Installation)

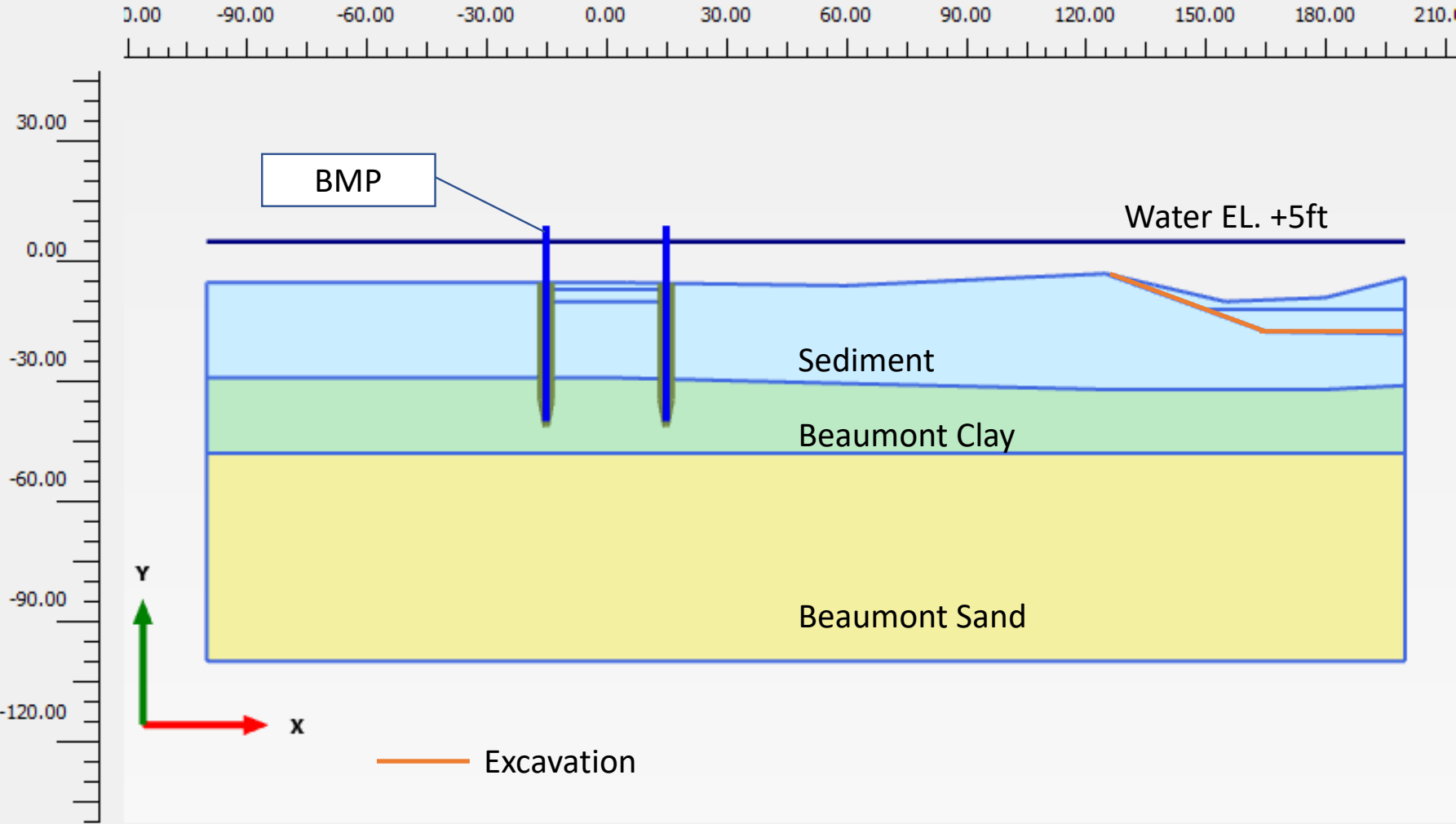

### Section C4 Soil Profile with BMP @ Analysis Stage 0 (Sheet Pile Installation)

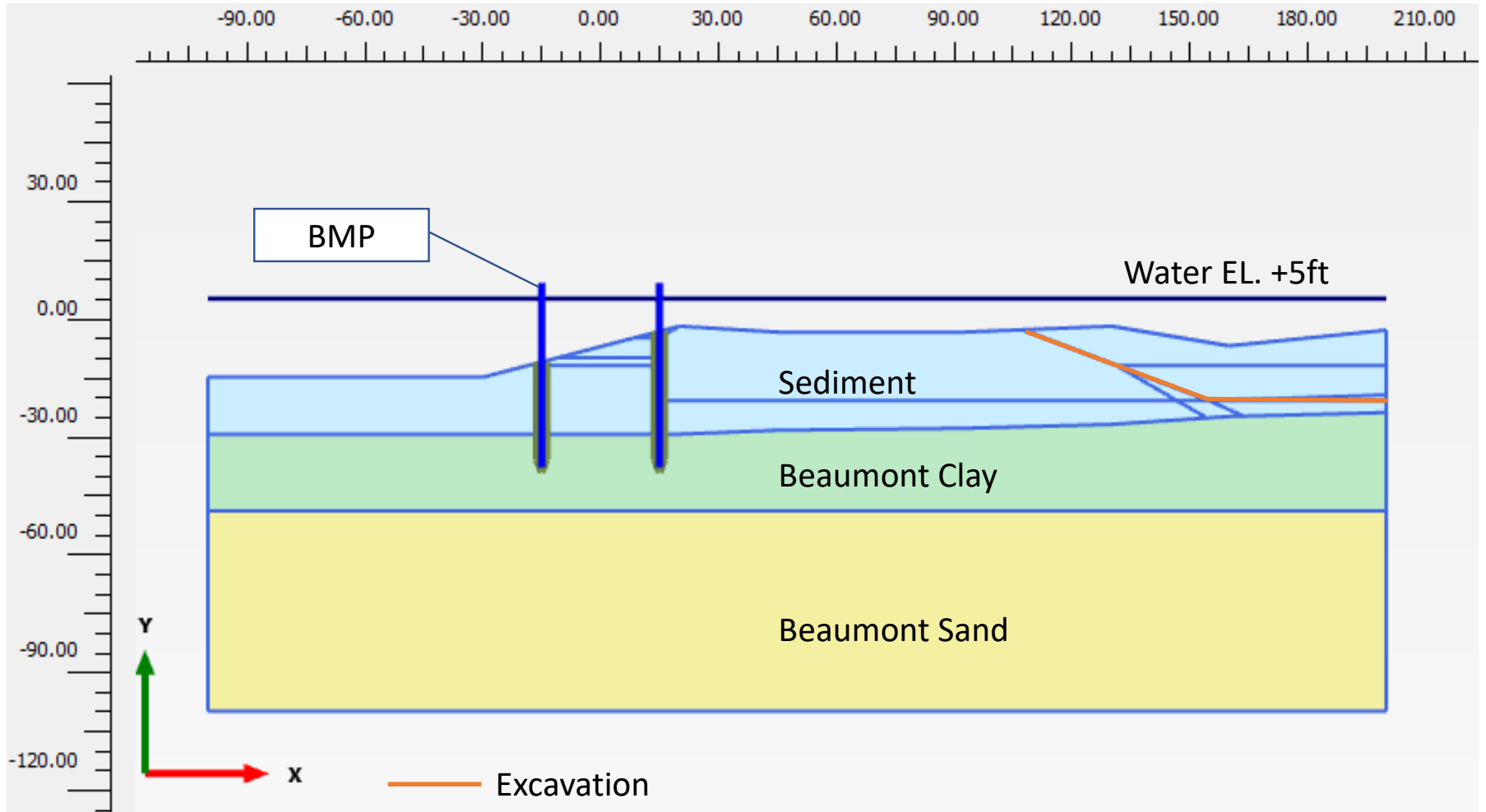

Section C4a Soil Profile with BMP @ Analysis Stage 0 (Sheet Pile Installation)

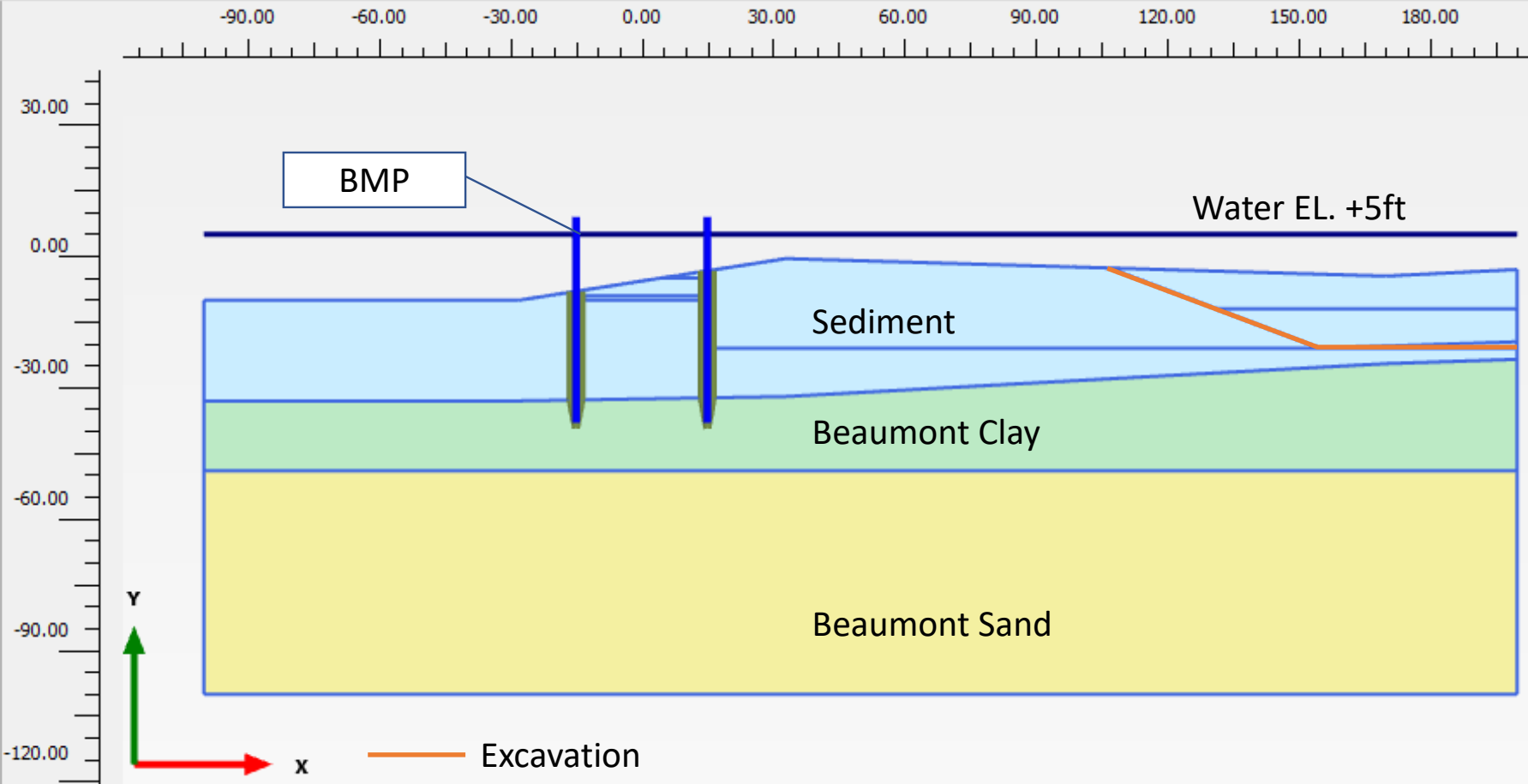

### Section C5 Soil Profile with BMP @ Analysis Stage 0 (Sheet Pile Installation)

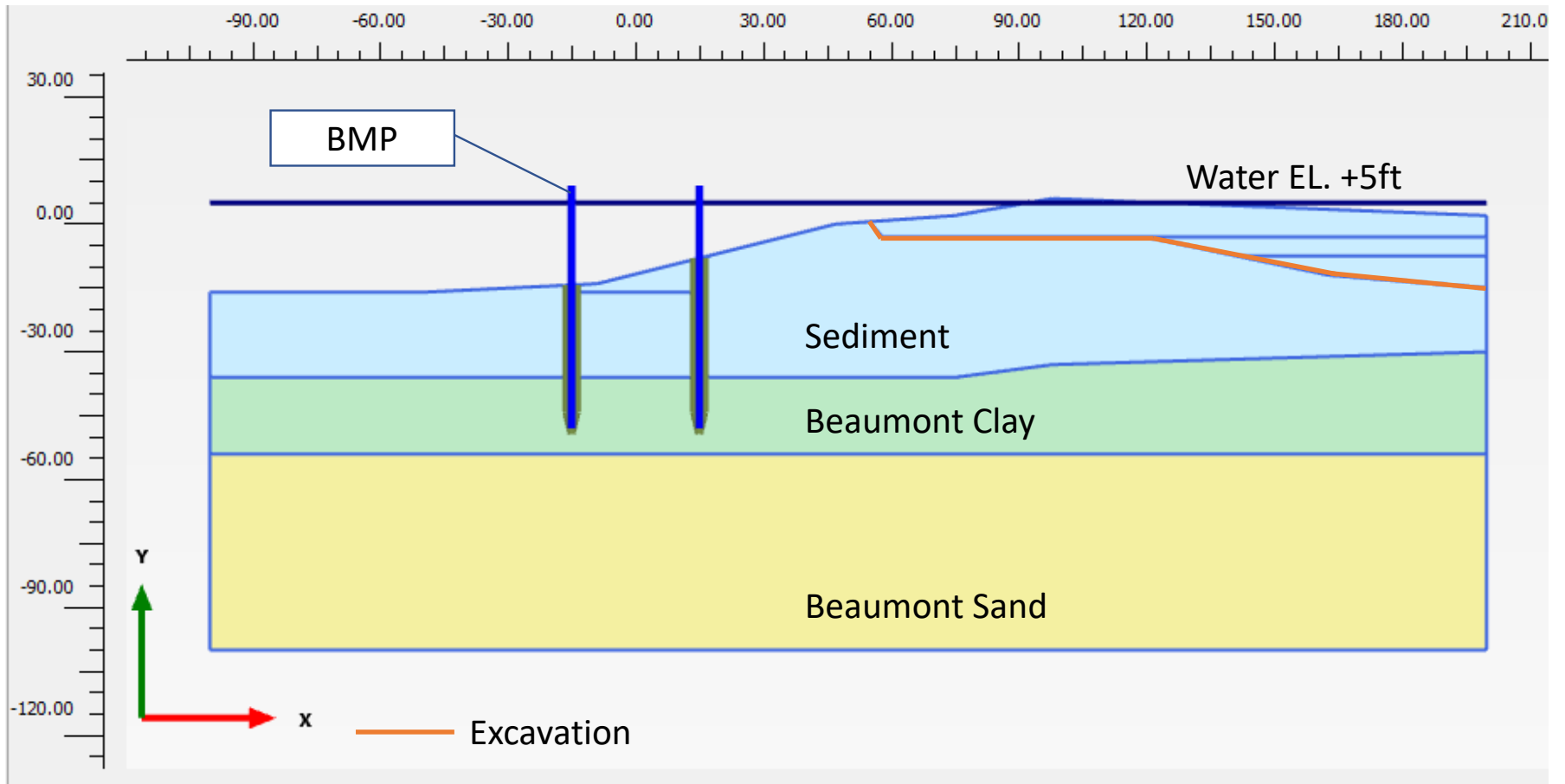

### Section C6 Soil Profile with BMP @ Analysis Stage 0 (Sheet Pile Installation)

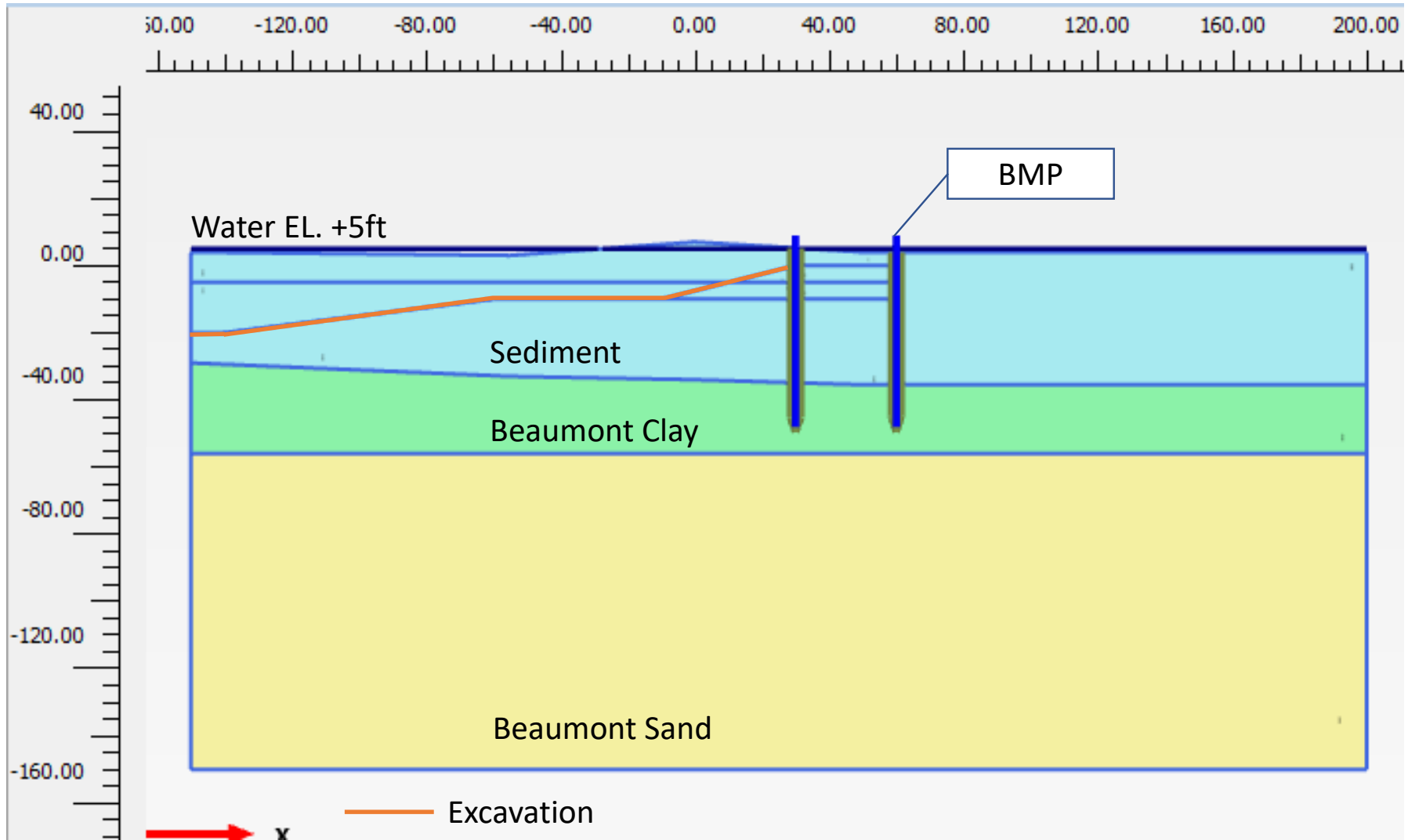

### Section C7 Soil Profile with BMP @ Analysis Stage 0 (Sheet Pile Installation)

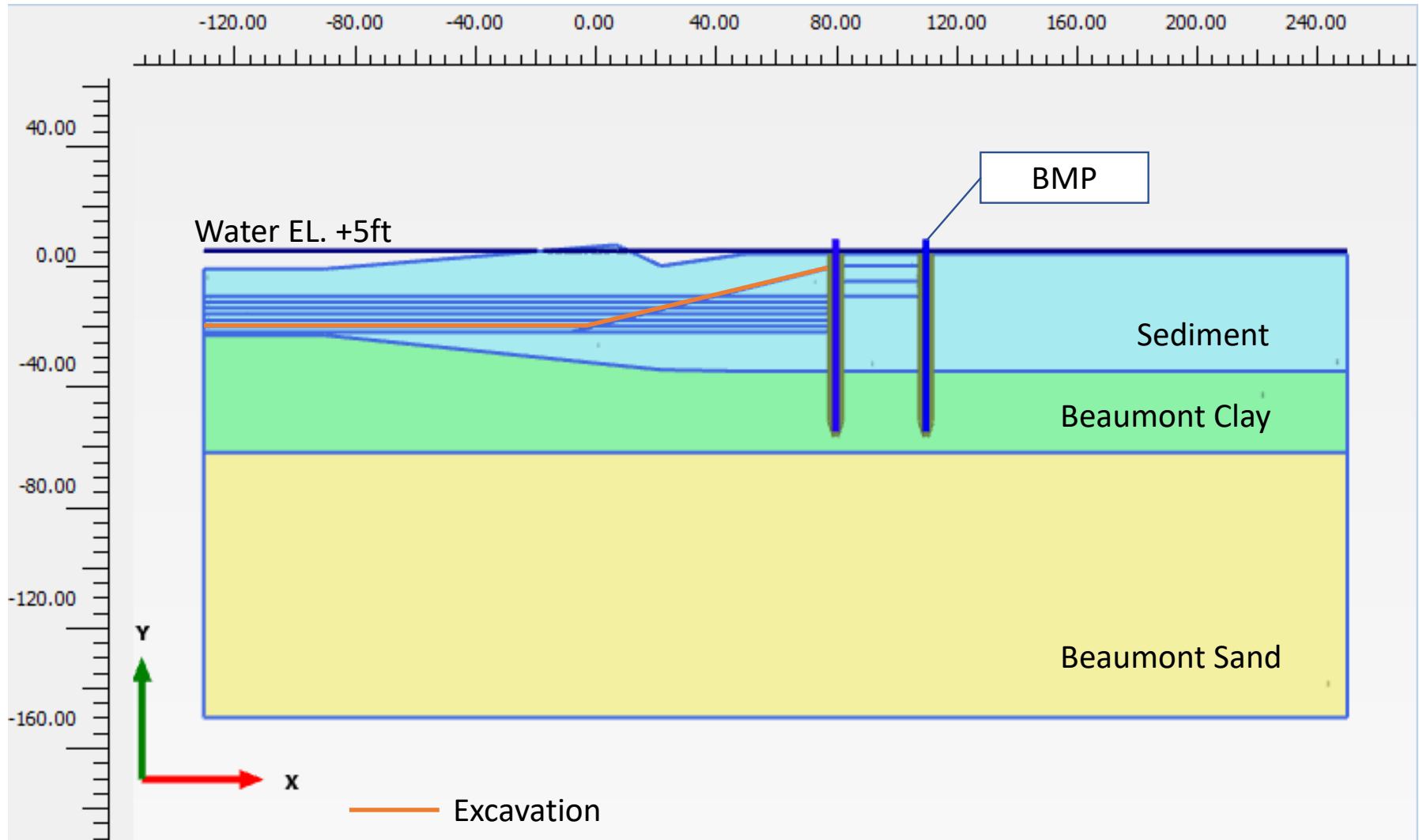

# **Attachment 3**

## **Structural Calculations**

- 3.1 BMP Calculations**
- 3.2 Scour Protection – BMP Exterior**
- 3.3 Scour Protection – BMP Interior**
- 3.4 Wind Load Evaluation**
- 3.5 Sheet Pile Seepage Evaluation**
- 3.6 Barge Impact Evaluation**
- 3.7 WEAP Output**
- 3.8 Velocity Buoy Data Processing**
- 3.9 Wind and Wave Evaluation**



Client IPC and MIMC Job Number 11215702 Sheet \_\_\_\_\_  
Project San Jacinto River Waste Pits Site Sheets By S.Chilka Date 07-11-2024  
Subject BMP Design Checked By \_\_\_\_\_ Date \_\_\_\_\_

APPENDIX I - BMP STRUCTURAL DESIGN REPORT  
**ATTACHMENT 3.1**  
**BMP DESIGN CALCULATIONS**



Client IPC & MIMC Job Number 12606491 Sheet \_\_\_\_\_  
 Project San Jacinto River Waste Pits Site Sheets By SC Date 07/04/2024  
 Subject Design Summary Checked By \_\_\_\_\_ Date \_\_\_\_\_

Elevations (ft)	Usual	Unusual
Top of Wall	+10	10
Top of Water Outside	+5	10

Steel Sheet Pile, Fy

60 ksi

Loading Condition	Allowable Stress Factor	
	Moment & Axial Load	Shear
Usual, U	0.50	0.33
Unusual, UNU	0.67	0.44
Extreme, EXT	0.88	0.58

Sacrificial thickness (tc) - for accounting corrosion  
 Corroded flange thickness (trf) - two exposed faces  
 Corroded web thickness (trw) - two exposed faces  
 Corroded section modulus Sr  
 Corroded section area Avr

0.0175	in
tf-(2tc)	in
tw-(2tc)	in
(trf/tf)*S	in <sup>3</sup> /ft
(trw/tw)*Av	in <sup>2</sup> /ft

#### Corroded Section Capacities

Sheet Pile Section	S (in <sup>3</sup> /ft)	tf(in)	trf(in)	Sr (in <sup>3</sup> /ft)	Moment (kip.ft / LF)		
					U	UNU	EXT
AZ 26-700	48.40	0.48	0.45	44.87	112	149	196
AZ 36-700N	66.80	0.59	0.56	62.84	157	209	275
AZ 42-700N	78.20	0.71	0.67	74.34	186	247	325

Sheet Pile Section	Av (in <sup>2</sup> /ft)	tw(in)	trw(in)	Avr (in <sup>2</sup> /ft)	Shear (kip / LF)		
					U	UNU	EXT
AZ 26-700	8.69	0.48	0.45	8.06	160	212	279
AZ 36-700N	8.67	0.44	0.41	7.98	158	210	276
AZ 42-700N	10.83	0.55	0.52	10.14	201	267	351

#### Sheet Pile Design Summary

Section	Sheet Pile Section	Moment (kip.ft / LF)		Shear (kip / LF)		Governing DCR	
		U	UNU	U	UNU	Moment	Shear
C1	AZ36-700N	129.0	149.6	9.8	11.2	0.82	0.06
C2	AZ42-700N	117.5	248.5	8.7	20.0	1.01	0.07
C3	AZ36-700N	131.0	153.4	11.7	13.1	0.83	0.07
C4	AZ36-700N	116.8	120.4	11.2	11.2	0.74	0.07
C5	AZ36-700N	137.0	146.9	10.6	11.6	0.87	0.07
C6	AZ26-700	47.6	59.2	6.4	7.2	0.42	0.04
C7	AZ26-700	62.4	98.8	7.7	8.6	0.66	0.05

DCR = Demand to Capacity Ratio



Client IPC & MIMC Job Number 12606491 Sheet \_\_\_\_\_  
 Project San Jacinto River Waste Pits Site Sheets By SC Date 07/04/2024  
 Subject Design Summary Checked By \_\_\_\_\_ Date \_\_\_\_\_

**Tie Rod Summary**

Section	Dia (in)	Spacing used in		Analysis Demand (kips)	Demand 100% (kips)	Demand 150% (kips)	Capacity (kips)	DCR
		Analysis (ft)	Drawings (ft)					
C1	2.25	10	5	120	60	90	145	0.62
C2	3	6	5	106	89	133	259	0.51
C3	2.25	6	5	90	75	112	145	0.77
C4	2.25	8	5	105	65	98	145	0.68
C5	2.25	6	5	81	68	102	145	0.70
C6	2.25	10	5	87	43	65	145	0.45
C7	2.25	5	5	52	52	78	145	0.54

DCR = Demand to Capacity Ratio

Demand 100% = Analysis Demand scaled for spacing shown on drawings

Demand 150% = Demand increased by 150% to account for broken adjacent tie-rod

Demands from C3 govern design for 2.25-in bar

Demands from C2 govern design of 3.00-in bar

**Waler Summary**

Section	Waler Section	Waler Section DCR	Splice Connection Detail				Conn. DCR
			Plate Size (in X in)	Plate Thk. (in)	No of Bolts	Bolt Dia (in)	
C1	MC 12X35	0.64	24X8	0.75	12	1.25	0.59
C2	MC 18X45.8	0.76	24X8	1.25	12	1.375	0.82
C3	MC 12X35	0.85	24X8	0.75	12	1.25	0.79
C4	MC 12X35	0.74	24X8	0.75	12	1.25	0.69
C5	MC 12X35	0.85	24X8	0.75	12	1.25	0.79
C6	MC 12X35	0.64	24X8	0.75	12	1.25	0.59
C7	MC 12X35	0.64	24X8	0.75	12	1.25	0.59

DCR = Demand to Capacity Ratio

Waler and Waler Connection DCRs were calculated in 90% RD. Demands have reduced with increase in sheet pile size in 100% RD. Same waler sections are appropriate. No revisions to calculations required.



Client IPC & MIMC Job Number 12606491 Sheet \_\_\_\_\_  
 Project San Jacinto River Waste Pits Site Sheets By SC Date 07/04/2024  
 Subject Analysis Output - PLAXIS Checked By \_\_\_\_\_ Date \_\_\_\_\_

Analysis Section	Drainage Condition	Stage	Sheet Pile			Embed in BCF ft	BSF Elevation ft
			Section	Length ft	Tip Elev ft		
C1	Drained	Usual	AZ 36-700N	50	-40	8	-60
		Unusual					
	UnDrained	Usual					
		Unusual					
C2	Drained	Usual	AZ 42-700N	55	-45	10	-48 to -71
		Unusual					
	UnDrained	Usual					
		Unusual					
C3, C3A	Drained	Usual	AZ 36-700N	49	-39	11	-48 to -66
		Unusual					
	UnDrained	Usual					
		Unusual					
C4, C4A	Drained	Usual	AZ 36-700N	47	-37	6	-49
		Unusual					
	UnDrained	Usual					
		Unusual					
C5	Drained	Usual	AZ 36-700N	57	-47	12	-54
		Unusual					
	UnDrained	Usual					
		Unusual					
C6	Drained	Usual	AZ 26-700	57	-47	12	-56
		Unusual					
	UnDrained	Usual					
		Unusual					
C7	Drained	Usual	AZ 26-700	61	-51	20	-62
		Unusual					
	UnDrained	Usual					
		Unusual					

**Notes:**

- Undrained Undrained (Sediments + BCF) + SS
- Usual Usual Load Condition at End of Excavation
- Unusual Unusual Load Condition with Water at Top of Wall on BMP Exterior
- BCF Beaumont Clay Formation
- BSF Beaumont Sand Formation
- All Elevations in NAVD88



Client IPC & MIMC Job Number 12606491 Sheet \_\_\_\_\_  
 Project San Jacinto River Waste Pits Site Sheets By SC Date 07/04/2024  
 Subject Analysis Output - PLAXIS Checked By \_\_\_\_\_ Date \_\_\_\_\_

Analysis Section	Drainage Condition	Stage	Demand Loads			Deflection	Tie Rod		
			Moment	Shear	Tie-Rod		Diameter	Spacing	Elev
			kip.ft / LF	kips / LF	kips	in	in	ft	ft
C1	Drained	Usual	71	7	70	6	2.25	10	5
		Unusual	91	8	91	8			
	UnDrained	Usual	129	10	107	8			
		Unusual	150	11	120	11			
C2	Drained	Usual	93	9	59	5	3.00	6	3
		Unusual	107	9	66	7			
	UnDrained	Usual	118	8	57	7			
		Unusual	249	20	106	19			
C3, C3A	Drained	Usual	81	10	64	6	2.25	6	3
		Unusual	99	11	77	9			
	UnDrained	Usual	131	12	82	8			
		Unusual	153	13	90	10			
C4, C4A	Drained	Usual	70	7	63	2	2.25	8	3
		Unusual	78	7	74	3			
	UnDrained	Usual	117	11	105	3			
		Unusual	120	11	101	2			
C5	Drained	Usual	75	8	55	4	2.25	6	3
		Unusual	90	9	66	6			
	UnDrained	Usual	137	11	77	5			
		Unusual	147	12	81	6			
C6	Drained	Usual	33	5	59	3	2.25	10	3
		Unusual	43	6	8	5			
	UnDrained	Usual	48	6	74	4			
		Unusual	59	7	87	6			
C7	Drained	Usual	62	7	40	6	2.25	5	3
		Unusual	99	9	52	9			
	UnDrained	Usual	60	8	44	6			
		Unusual	91	8	51	9			



Client IPC & MIMC Job Number 12606491 Sheet \_\_\_\_\_  
 Project San Jacinto River Waste Pits Site Sheets By SC Date 07/04/2024  
 Subject Tie Rod Capacity Check Checked By \_\_\_\_\_ Date \_\_\_\_\_

## DESIGN OF TIE ROD SECTION, AISC 360-22

### Tie Rod Design - 2.25 in diameter bar

#### MATERIAL PROPERTIES

Steel Yield Stress  $F_{ybar} := 80\text{ksi}$

Steel Tensile Stress  $F_{ubbar} := 100\text{ksi}$

Tie rod nominal Diameter  $d_{bar} := 2.25\text{in}$

Refer table below from  
Nucor Skyline Manual

Tie rod approx. major Thread Diameter  $d_{bthr} := 2.438\text{in}$

Grade 80 ksi Yield Strength / 100 ksi Ultimate Strength									
Bar Designation	Nominal Diameter in mm	Grade	Min. Net Area Thru Threads in <sup>2</sup> mm <sup>2</sup>	Min. Ultimate Strength kips kN	Min. Yield Strength kips kN	Nominal Weight lbs/ft kg/m	Approx. Major Thread Diameter in mm	Thread Orientation	Max. Length ft m
#8	1 25	80	0.790 510.0	79.0 351	63.2 281	2.70 4.0	1.125 28.5	Left Hand	60 18.3
#9	1 1/8 28	80	1.000 645.0	100.0 445	80.0 356	3.40 5.1	1.250 32.0	Left Hand	60 18.3
#10	1 1/4 32	80	1.270 819.0	127.0 565	101.6 452	4.30 6.4	1.375 35.0	Left Hand	60 18.3
#11	1 3/8 35	80	1.560 1006.0	156.0 670	124.8 555	5.30 7.9	1.500 38.1	Left Hand	60 18.3
#14	1 3/4 45	80	2.250 1452.0	225.0 1001	180.0 801	7.65 11.4	1.875 47.6	Right Hand	60 18.3
#18	2 1/4 55	80	4.000 2581.0	400.0 1779	320.0 1423	13.60 20.2	2.438 62.0	Right Hand	60 18.3
#20	2 1/2 64	80	4.910 3168.0	491.0 2184	392.8 1747	16.69 24.8	2.750 70.0	Right Hand	60 18.3
#24	3 76	80	7.070 4561.0	707.0 3145	565.6 2516	24.10 35.9	3.250 82.6	Right Hand	60 18.3
#28	3 1/2 89	80	9.610 6200.0	961.0 4275	768.8 3420	32.70 48.7	3.750 95.3	Right Hand	60 18.3

Cold rolled threaded bars conform to the physical and chemical requirements of ASTM A615 Grade 80 ksi "Standard Specification for Deformed Carbon Steel Bars for Concrete Reinforcement".



Client IPC & MIMC Job Number 12606491 Sheet \_\_\_\_\_  
Project San Jacinto River Waste Pits Site Sheets By SC Date 07/04/2024  
Subject Tie Rod Capacity Check Checked By \_\_\_\_\_ Date \_\_\_\_\_

Deduct thickness for corrosion  $t_c := 0.0175 \text{ in}$  Design Report

Bar Area - Through Threads - Corroded  $A_{\text{bar}} := \frac{\pi}{4} \cdot (d_{\text{bar}} - 2t_c)^2 = 3.85 \cdot \text{in}^2$

Length of Tie Rod  $L_{\text{bar}} := 30 \text{ ft}$

## ANALYSIS DEMAND LOADS

Tie rod Spacing  $S_{\text{bara}} := 6 \text{ ft}$

Tie rod Tension Demand  $F_{\text{barda}} := 90 \text{ kip}$

## REVISED DEMAND LOADS FOR SPACING ON DRAWINGS

Tie rod spacing on Drawings  $S_{\text{bar}} := 5 \text{ ft}$

Tension Demand for Spacing on Drawings  $F_{\text{bard}} := \frac{F_{\text{barda}} \cdot S_{\text{bar}}}{S_{\text{bara}}} = 75 \cdot \text{kip}$

## Tie Rod Demand Load to safeguard against Progressive Failure

In certain situations, progressive collapse of the structure may be a consequence of an extreme condition, i.e failure of a tie rod. Assuming the load from the failed tie rod is redistributed to adjacent tie rods resulting in an increase in the demand load on the tie rod by 50%

Tension Demand, assuming failure of one adjacent tie-rod  $F_{\text{pbard}} := 1.5 \cdot F_{\text{bard}} = 112.5 \cdot \text{kip}$



Client IPC & MIMC Job Number 12606491 Sheet \_\_\_\_\_  
 Project San Jacinto River Waste Pits Site Sheets By SC Date 07/04/2024  
 Subject Tie Rod Capacity Check Checked By \_\_\_\_\_ Date \_\_\_\_\_

## ALLOWABLE STRESS DESIGN CAPACITY

### D2 Tensile Strength of the Tie Rod

Overstrength Factors  $\Omega_{ty} := 1.67$  Tensile Yielding  
 $\Omega_{tr} := 2.0$  Tensile Rupture

Allowable tensile strength based on limit state of tensile yielding of gross section, Eq D2-1  $P_{ny} := \frac{F_{ybar} \cdot A_{barn}}{\Omega_{ty}} = 184.6 \cdot \text{kip}$

Shear Lag Factor, Table D3.1- Case 1  $U := 1$

Allowable tensile strength based on limit state of tensile rupture in net section, Eq D2-2  $P_{nr} := \frac{F_{ubarn} \cdot A_{barn} \cdot U}{\Omega_{tr}} = 192.7 \cdot \text{kip}$

### J3.6 Tensile Strength of Threaded Parts

Overstrength Factors  $\Omega_{thr} := 2.0$

Nominal Tensile Stress, Table J3.2 - Case 8  $F_{nt} := 0.75 \cdot F_{ubarn} = 75 \cdot \text{ksi}$

Allowable Tensile Strength of threaded parts based on limit state of tension rupture, Eq J3-1  $R_{nt} := \frac{F_{nt} \cdot A_{barn}}{\Omega_{thr}} = 144.5 \cdot \text{kip}$

Allowable Tensile Strength  $F_{barc} := \min(P_{ny}, P_{nr}, R_{nt}) = 144.5 \cdot \text{kip}$

Capacity Check

$$DCR_2 := \begin{cases} \frac{F_{pbard}}{F_{barc}} & \text{if } F_{barc} \geq F_{pbard} \\ \text{"Increase Bar Size"} & \text{otherwise} \end{cases} = 0.78$$



Client IPC & MIMC Job Number 12606491 Sheet \_\_\_\_\_  
 Project San Jacinto River Waste Pits Site Sheets By SC Date 07/04/2024  
 Subject Tie Rod Capacity Check Checked By \_\_\_\_\_ Date \_\_\_\_\_

## DESIGN OF TIE ROD SECTION, AISC 360-22

### Tie Rod Design - 3.0 in diameter bar

### MATERIAL PROPERTIES

Steel Yield Stress  $F_{ybar} := 80\text{ksi}$

Steel Tensile Stress  $F_{ubbar} := 100\text{ksi}$

Tie rod nominal Diameter  $d_{bar} := 3\text{in}$

Refer table below from  
Nucor Skyline Manual

Tie rod approx. major Thread Diameter  $d_{bthr} := 3.25\text{in}$

Grade 80 ksi Yield Strength / 100 ksi Ultimate Strength									
Bar Designation	Nominal Diameter in mm	Grade	Min. Net Area Thru Threads in <sup>2</sup> mm <sup>2</sup>	Min. Ultimate Strength kips kN	Min. Yield Strength kips kN	Nominal Weight lbs/ft kg/m	Approx. Major Thread Diameter in mm	Thread Orientation	Max. Length ft m
#8	1 25	80	0.790 510.0	79.0 351	63.2 281	2.70 4.0	1.125 28.5	Left Hand	60 18.3
#9	1 1/8 28	80	1.000 645.0	100.0 445	80.0 356	3.40 5.1	1.250 32.0	Left Hand	60 18.3
#10	1 1/4 32	80	1.270 819.0	127.0 565	101.6 452	4.30 6.4	1.375 35.0	Left Hand	60 18.3
#11	1 3/8 35	80	1.560 1006.0	156.0 670	124.8 555	5.30 7.9	1.500 38.1	Left Hand	60 18.3
#14	1 3/4 45	80	2.250 1452.0	225.0 1001	180.0 801	7.65 11.4	1.875 47.6	Right Hand	60 18.3
#18	2 1/4 55	80	4.000 2581.0	400.0 1779	320.0 1423	13.60 20.2	2.438 62.0	Right Hand	60 18.3
#20	2 1/2 64	80	4.910 3168.0	491.0 2184	392.8 1747	16.69 24.8	2.750 70.0	Right Hand	60 18.3
#24	3 76	80	7.070 4561.0	707.0 3145	565.6 2516	24.10 35.9	3.250 82.6	Right Hand	60 18.3
#28	3 1/2 89	80	9.610 6200.0	961.0 4275	768.8 3420	32.70 48.7	3.750 95.3	Right Hand	60 18.3

Cold rolled threaded bars conform to the physical and chemical requirements of ASTM A615 Grade 80 ksi "Standard Specification for Deformed Carbon Steel Bars for Concrete Reinforcement".



Client IPC & MIMC Job Number 12606491 Sheet \_\_\_\_\_  
Project San Jacinto River Waste Pits Site Sheets By SC Date 07/04/2024  
Subject Tie Rod Capacity Check Checked By \_\_\_\_\_ Date \_\_\_\_\_

Deduct thickness for corrosion  $t_c := 0.0175 \text{ in}$  Design Report

Bar Area - Through Threads - Corroded  $A_{\text{bar}} := \frac{\pi}{4} \cdot (d_{\text{bar}} - 2t_c)^2 = 6.9 \cdot \text{in}^2$

Length of Tie Rod  $L_{\text{bar}} := 30 \text{ ft}$

## ANALYSIS DEMAND LOADS

Tie rod Spacing  $S_{\text{bara}} := 6 \text{ ft}$

Tie rod Tension Demand  $F_{\text{barda}} := 106 \text{ kip}$

## REVISED DEMAND LOADS FOR SPACING ON DRAWINGS

Tie rod spacing on Drawings  $S_{\text{bar}} := 5 \text{ ft}$

Tension Demand for Spacing on Drawings  $F_{\text{bard}} := \frac{F_{\text{barda}} \cdot S_{\text{bar}}}{S_{\text{bara}}} = 88.33 \cdot \text{kip}$

## Tie Rod Demand Load to safeguard against Progressive Failure

In certain situations, progressive collapse of the structure may be a consequence of an extreme condition, i.e failure of a tie rod. Assuming the load from the failed tie rod is redistributed to adjacent tie rods resulting in an increase in the demand load on the tie rod by 50%

Tension Demand, assuming failure of one adjacent tie-rod  $F_{\text{pbard}} := 1.5 \cdot F_{\text{bard}} = 132.5 \cdot \text{kip}$



Client IPC & MIMC Job Number 12606491 Sheet \_\_\_\_\_  
 Project San Jacinto River Waste Pits Site Sheets By SC Date 07/04/2024  
 Subject Tie Rod Capacity Check Checked By \_\_\_\_\_ Date \_\_\_\_\_

## ALLOWABLE STRESS DESIGN CAPACITY

### D2 Tensile Strength of the Tie Rod

Overstrength Factors  $\Omega_{ty} := 1.67$  Tensile Yielding  
 $\Omega_{tr} := 2.0$  Tensile Rupture

Allowable tensile strength based on limit state of tensile yielding of gross section, Eq D2-1  

$$P_{ny} := \frac{F_{ybar} \cdot A_{barn}}{\Omega_{ty}} = 330.8 \cdot \text{kip}$$

Shear Lag Factor, Table D3.1- Case 1  $U := 1$

Allowable tensile strength based on limit state of tensile rupture in net section, Eq D2-2  

$$P_{nr} := \frac{F_{ubarn} \cdot A_{barn} \cdot U}{\Omega_{tr}} = 345.2 \cdot \text{kip}$$

### J3.6 Tensile Strength of Threaded Parts

Overstrength Factors  $\Omega_{thr} := 2.0$

Nominal Tensile Stress, Table J3.2 - Case 8  
 $F_{nt} := 0.75 \cdot F_{ubarn} = 75 \cdot \text{ksi}$

Allowable Tensile Strength of threaded parts based on limit state of tension rupture, Eq J3-1  

$$R_{nt} := \frac{F_{nt} \cdot A_{barn}}{\Omega_{thr}} = 258.9 \cdot \text{kip}$$

Allowable Tensile Strength  $F_{barc} := \min(P_{ny}, P_{nr}, R_{nt}) = 258.9 \cdot \text{kip}$

Capacity Check

$$DCR_2 := \begin{cases} \frac{F_{pbard}}{F_{barc}} & \text{if } F_{barc} \geq F_{pbard} \\ \text{"Increase Bar Size"} & \text{otherwise} \end{cases} = 0.51$$



Client IPC & MIMC Job Number 11215702 Sheet \_\_\_\_\_  
Project San Jacinto River Waste Pits Site Sheets By I.Goel Date 06/03/2022  
Subject Waler Section & Splice Connection Design Calculation Checked By S.Chilka Date 06/03/2022

## Analysis Demand Load on Waler - Sec C1, C3A, C4A, C6

Tie Rod Tension Demand Load from Analysis

$$T_{\text{roda}} := 131.3 \text{ kip}$$

Reduced to 120 kips  
July 2024  
This calculation is still  
okay.

Tie Rod Spacing

$$S_{\text{roda}} := 10 \text{ ft}$$

The tie rod spacing assumed in analysis results in large demand loads and section size for waler. To optimize section selection, tie rods will be closely spaced. Closely spaced tie rods will result in lower demand loads.

Revised Tie Rod Spacing

$$S_{\text{rod}} := 5 \text{ ft}$$

Revised Tie Rod Tension Demand

$$T_{\text{rod}} := T_{\text{roda}} \cdot \frac{S_{\text{rod}}}{S_{\text{roda}}} = 65.65 \cdot \text{kip}$$

Demand Load on waler

$$w_{\text{dl}} := \frac{T_{\text{rod}}}{S_{\text{rod}}} = 13.13 \cdot \frac{\text{kip}}{\text{ft}}$$

## Demand Load on Waler to safeguard against progressive failure

In certain situations, progressive collapse of the structure may be a consequence of an extreme condition ie. failure of a tie rod. The walling to the main wall will need to be checked to ensure that it will not collapse if the span between tie rods doubles following the loss of a tie rod.

SAP2000 analysis is used to calculate the bending moment and shear force demand on the waler for both the cases. Case 1 - without failure of a tie rod and, Case 2 - with failure of a tie rod.

For Case 1 - Continuous beam with four equal spans of length  $S_{\text{rod}}$  is analyzed

For Case 2 - Continuous beam with three spans of length  $S_{\text{rod}}$  -  $2S_{\text{rod}}$  -  $S_{\text{rod}}$  is analyzed

Waler Design is governed by the demands from Case 2



Client IPC & MIMC Job Number 11215702 Sheet \_\_\_\_\_  
Project San Jacinto River Waste Pits Site Sheets By I.Goel Date 06/03/2022  
Subject Waler Section & Splice Connection Design Calculation Checked By S.Chilka Date 06/03/2022

### Bending Moment Diagram - Case 1

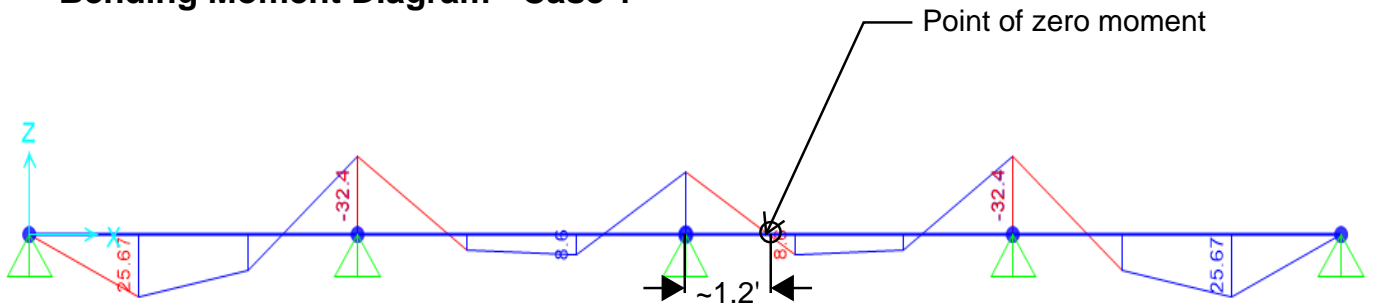

Bending Moment demand from SAP2000 -  $M_{dsap} = 32.5 \text{ Kip-ft}$

### Shear Force Diagram - Case 1

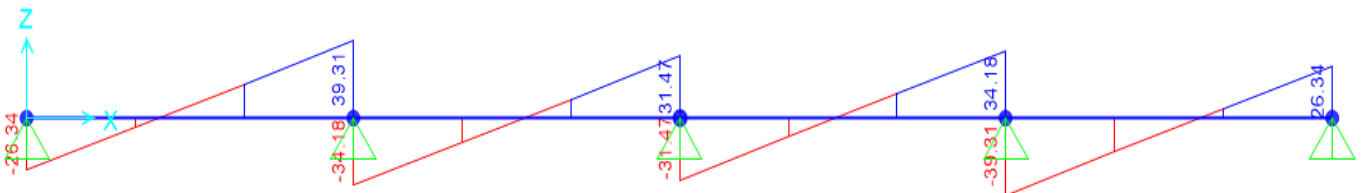

Shear Force demand from SAP2000 -  $V_{dsap} = 39.5 \text{ Kip}$



Client IPC & MIMC Job Number 11215702 Sheet \_\_\_\_\_  
Project San Jacinto River Waste Pits Site Sheets By I.Goel Date 06/03/2022  
Subject Waler Section & Splice Connection Design Calculation Checked By S.Chilka Date 06/03/2022

### Bending Moment Diagram - Case 2

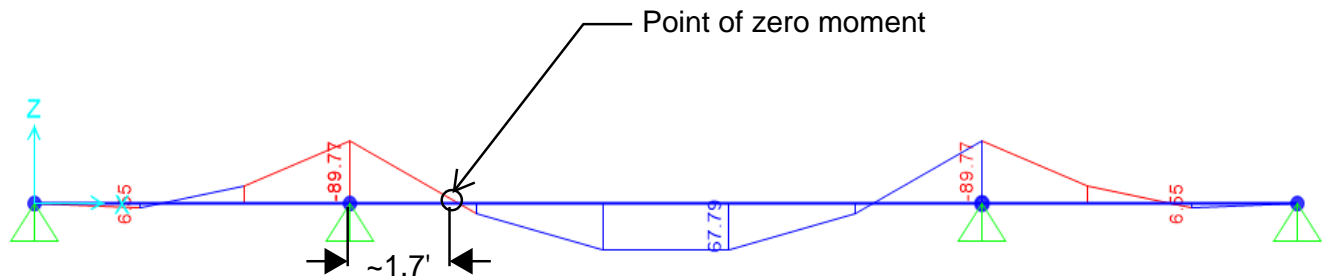

Bending Moment demand from SAP2000 -  $M_{dsap} = 90\text{Kip-ft}$

### Shear Force Diagram - Case 2

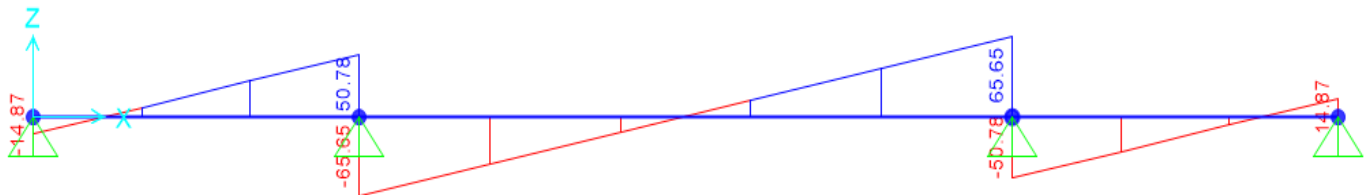

Shear Force demand from SAP2000 -  $V_{dsap} = 66\text{Kip}$



Client IPC & MIMC Job Number 11215702 Sheet \_\_\_\_\_  
Project San Jacinto River Waste Pits Site Sheets By I.Goel Date 06/03/2022  
Subject Waler Section & Splice Connection Design Calculation Checked By S.Chilka Date 06/03/2022

## Waler Cross-Section

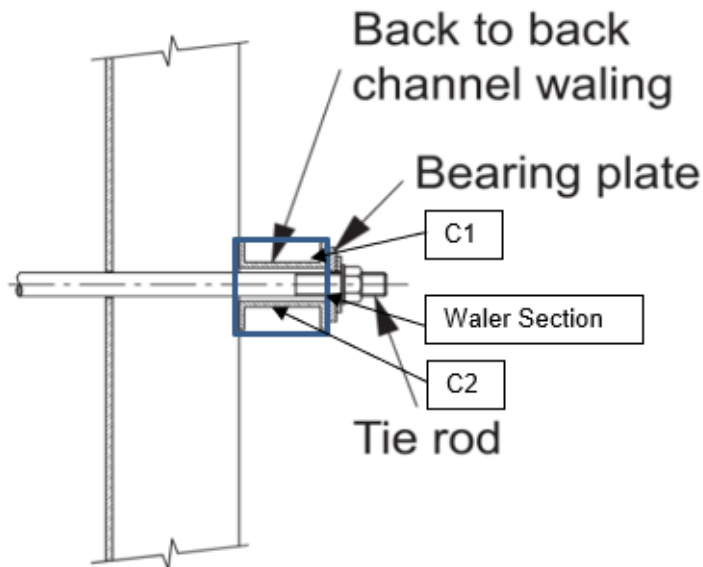

Waler is made of two channel sections C1 and C2

## Design of corroded waler section, AISC 360-16

Bending moment demand on waler from SAP2000

$$M_{dsap} := 90 \text{ kip}\cdot\text{ft}$$

Shear force demand on waler from SAP2000

$$V_{dsap} := 66 \text{ kip}$$

Bending moment demand on C1 or C2

$$M_d := \frac{M_{dsap}}{2} = 45 \text{ kip}\cdot\text{ft}$$

Shear force demand on C1 or C2

$$V_d := \frac{V_{dsap}}{2} = 33 \text{ kip}$$



Client IPC & MIMC Job Number 11215702 Sheet \_\_\_\_\_  
Project San Jacinto River Waste Pits Site Sheets By I.Goel Date 06/03/2022  
Subject Waler Section & Splice Connection Design Calculation Checked By S.Chilka Date 06/03/2022

Steel yield stress  $F_y := 36\text{ksi}$

Steel tensile stress  $F_u := 58\text{ksi}$

Modulus of Elasticity of steel  $E := 29000\text{ksi}$

Sacrificial thickness - for accounting corrosion  $t_c := 0.0175\text{in}$  Refer Basis of Design report

### Channel Section Dimensional Parameters (MC12X35)

Depth  $d := 12\text{in}$

Web thickness  $t_w := 0.4375\text{in}$

Flange thickness  $t_f := 0.6875\text{in}$

Flange width  $b_f := 3.75\text{in}$

Distance  $k := 1.3125\text{in}$

### Corroded Channel Section Dimensional Parameters (MC12X35)

Web thickness  $t_{wc} := t_w - 2t_c = 0.4\text{in}$

Flange thickness  $t_{fc} := t_f - 2t_c = 0.65\text{in}$



Client IPC & MIMC Job Number 11215702 Sheet \_\_\_\_\_  
Project San Jacinto River Waste Pits Site Sheets By I.Goel Date 06/03/2022  
Subject Waler Section & Splice Connection Design Calculation Checked By S.Chilka Date 06/03/2022

## Sectional Properties of Corroded Section

Plastic modulus about x axis

$$Z_x := \left[ (bf) \cdot \frac{(d)^2}{4} \right] - \left[ [(bf) - (twc)] \cdot \frac{[(d) - [2 \cdot (tfc)]]^2}{4} \right] = 39.28 \cdot \text{in}^3$$

Elastic modulus about x axis

$$S_x := \frac{\left[ (bf) \cdot \frac{(d)^3}{12} \right] - \left[ [(bf) - (twc)] \cdot \frac{[(d) - [2 \cdot (tfc)]]^3}{12} \right]}{(d) \cdot 0.5} = 33.12 \cdot \text{in}^3$$

Torsion constant

$$J := \frac{\left[ 2 \cdot (bf) \cdot (tfc)^3 \right] + \left[ [(d) - (tfc)] \cdot (twc)^3 \right]}{3} = 0.94 \cdot \text{in}^4$$

Moment of Inertia about external edge  
of web parallel to y axis

$$I_{y0} := \left[ [(d) - [2 \cdot (tfc)]] \cdot \frac{(twc)^3}{3} \right] + \left[ (bf)^3 \cdot (tfc) \cdot \frac{2}{3} \right] = 23.17 \cdot \text{in}^4$$

Cross sectional area

$$A_c := [2 \cdot (bf) \cdot (tfc)] + [(d) - [2 \cdot (tfc)]] \cdot (twc) = 9.2 \cdot \text{in}^2$$



Client IPC & MIMC Job Number 11215702 Sheet \_\_\_\_\_  
Project San Jacinto River Waste Pits Site Sheets By I.Goel Date 06/03/2022  
Subject Waler Section & Splice Connection Design Calculation Checked By S.Chilka Date 06/03/2022

Distance of centroid from external edge  
of web

$$x_c := \frac{\left[ \left[ (d) - [2 \cdot (tfc)] \right] \cdot \frac{(twc)^2}{2} \right] + \left[ (bf)^2 \cdot (tfc) \right]}{A_c} = 1.09 \cdot \text{in}$$

Moment of inertia about y axis

$$I_y := I_{y0} - (A_c \cdot x_c^2) = 12.21 \cdot \text{in}^4$$

Distance between flange centroids

$$h_o := (d) - (tfc) = 11.35 \cdot \text{in}$$

Warping torsional constant

$$C_w := \frac{\left[ (tfc) \cdot (bf)^3 \cdot [(d) - (tfc)]^2 \right] \cdot \left[ [3 \cdot (bf) \cdot (tfc)] + [2 \cdot (twc) \cdot [(d) - (tfc)]] \right]}{12 \cdot \left[ [6 \cdot (bf) \cdot (tfc)] + [(twc) \cdot [(d) - (tfc)]] \right]}$$

$$C_w = 316.03 \cdot \text{in}^6$$

radius of gyration about y axis

$$r_y := \sqrt{\frac{I_y}{A_c}} = 1.15 \cdot \text{in}$$

Overstrength factor for flexure

$$\Omega_f := 1.67$$

Overstrength factor for shear

$$\Omega_v := 1.67$$

## Classification of sections for local buckling - Section B4.1

### Classification of flanges in flexure - Table B4.1b (case 10)

Width - to - Thickness Ratio for flange

$$a_f := \frac{bf}{tfc} = 5.75$$



Client IPC & MIMC Job Number 11215702 Sheet \_\_\_\_\_  
 Project San Jacinto River Waste Pits Site Sheets By I.Goel Date 06/03/2022  
 Subject Waler Section & Splice Connection Design Calculation Checked By S.Chilka Date 06/03/2022

Limiting width to thickness ratio for compact flange section about major/minor axis

$$\lambda_{cf} := 0.38 \cdot \sqrt{\frac{E}{F_y}} = 10.79$$

Limiting width to thickness ratio for non compact flange section about major/minor axis

$$\lambda_{nf} := 1 \sqrt{\frac{E}{F_y}} = 28.38$$

#### Classification of web in flexure - Table B4.1b (case 15)

Width - to - Thickness Ratio for web

$$a_w := \frac{(d) - [2 \cdot (k - 2t_c)]}{t_{wc}} = 23.47$$

Limiting width to thickness ratio for compact web section about major/minor axis

$$\lambda_{cw} := 3.76 \cdot \sqrt{\frac{E}{F_y}} = 106.72$$

Limiting width to thickness ratio for non compact web section about major/minor axis

$$\lambda_{nw} := 5.7 \sqrt{\frac{E}{F_y}} = 161.78$$

$$cn_{ff} := \begin{cases} \text{"Compact flange"} & \text{if } a_f \leq \lambda_{cf} \\ \text{"Non compact flange"} & \text{if } \lambda_{cf} \leq a_f \leq \lambda_{nf} \\ \text{"Slender flange"} & \text{otherwise} \end{cases} = \text{"Compact flange"}$$

$$cn_{wf} := \begin{cases} \text{"Compact web"} & \text{if } a_w \leq \lambda_{cw} \\ \text{"Non compact web"} & \text{if } \lambda_{cw} \leq a_w \leq \lambda_{nw} \\ \text{"Slender flange web"} & \text{otherwise} \end{cases} = \text{"Compact web"}$$

#### Allowable Stress Shear Design - Chapter G

Web area

$$A_w := (d) \cdot (t_{wc}) = 4.83 \cdot \text{in}^2$$

Web plate buckling coefficient

$$K_v := 5.34$$



Client IPC & MIMC Job Number 11215702 Sheet \_\_\_\_\_  
 Project San Jacinto River Waste Pits Site Sheets By I.Goel Date 06/03/2022  
 Subject Waler Section & Splice Connection Design Calculation Checked By S.Chilka Date 06/03/2022

$$r := 1.1 \cdot \left( K_v \cdot \frac{E}{F_y} \right)^{\frac{1}{2}} = 72.15$$

$$r1 := \frac{(d) - [2 \cdot (tfc)]}{twc} = 26.57$$

Web shear coefficient, Eq G2-3  
and Eq G2-4

$$Cv1 := \begin{cases} 1 & \text{if } r \geq r1 \\ \frac{r}{r1} & \text{if } r < r1 \end{cases}$$

$$Cv1 = 1$$

Nominal shear strength, Eq G2-1

$$Vn := 0.6 \cdot Cv1 \cdot Aw \cdot Fy = 104.33 \cdot \text{kip}$$

Allowable shear strength

$$vc := \frac{Vn}{\Omega_v} = 62.47 \cdot \text{kip}$$

Check for shear strength

$$\text{Checkvc} := \begin{cases} \frac{Vd}{vc} & \text{if } vc \geq Vd \\ \text{"Revise waler section"} & \text{if } vc < Vd \end{cases}$$

$$\text{Checkvc} = 0.53$$

## Allowable Stress Flexure design about major axis - Chapter F

### Yielding - Section F2.1

Nominal flexural strength for yielding, Eq F2-1

$$Mnyld := Fy \cdot Zx = 117.83 \cdot \text{kip} \cdot \text{ft}$$



Client IPC & MIMC Job Number 11215702 Sheet \_\_\_\_\_  
Project San Jacinto River Waste Pits Site Sheets By I.Goel Date 06/03/2022  
Subject Waler Section & Splice Connection Design Calculation Checked By S.Chilka Date 06/03/2022

### Lateral Torsional Buckling - Section F2.2

Unbraced length  $L_b := S_{rod} \cdot 2 = 120 \cdot \text{in}$

Limiting unbraced length for yielding Eq F2-5  $L_p := 1.76 \cdot r_y \cdot \sqrt{\frac{E}{F_y}} = 57.55 \cdot \text{in}$

Eq F2-8b  $cf := \left(\frac{h_o}{2}\right) \cdot \sqrt{\frac{I_y}{C_w}} = 1.12$

Eq F2-7  $r_{ts} := \sqrt{\frac{\sqrt{I_y \cdot C_w}}{S_x}} = 1.37 \cdot \text{in}$

Eq F2-6 
$$L_r := 1.95 \cdot r_{ts} \cdot \frac{E \cdot \sqrt{\left(\frac{J \cdot cf}{S_x \cdot h_o}\right) + \left(\frac{J \cdot cf}{S_x \cdot h_o}\right)^2 + \left[6.76 \cdot \left(0.7 \cdot \frac{F_y}{E}\right)^2\right]}}{(0.7 \cdot F_y)} = 245.54 \cdot \text{in}$$

From SAP2000 analysis, for calculation of  $C_b$  ( $L_p < L_b \leq L_r$ )

Moment at quarter point of unbraced segment  $M_a := 28.4 \text{kip} \cdot \text{ft}$

Moment at center line of unbraced segment  $M_b := 67.8 \text{kip} \cdot \text{ft}$

Moment at three quarter point of unbraced segment  $M_c := 28.4 \text{kip} \cdot \text{ft}$

Maximum moment in unbraced segment  $M_{abs} := 89.8 \text{kip} \cdot \text{ft}$



Client IPC & MIMC Job Number 11215702 Sheet \_\_\_\_\_  
Project San Jacinto River Waste Pits Site Sheets By I.Goel Date 06/03/2022  
Subject Waler Section & Splice Connection Design Calculation Checked By S.Chilka Date 06/03/2022

Plastic moment capacity

$$M_p := M_{nyld}$$

Lateral torsional buckling modification factor, Eq F1-1

$$C_b := 12.5 \cdot \frac{M_{abs}}{[(2.5 \cdot M_{abs}) + (3 \cdot M_a) + (4 \cdot M_b) + (3 \cdot M_c)]} = 1.69$$

Nominal flexural strength for lateral torsional buckling - Eq F2-2

$$M_{ntlb} := C_b \cdot \left[ M_p - (M_p - 0.7 \cdot F_y \cdot S_x) \cdot \frac{(L_b - L_p)}{(L_r - L_p)} \right]$$

$$M_{ntlb} = 171.54 \cdot \text{kip} \cdot \text{ft}$$

Nominal flexural strength

$$M_n := \min(M_{nyld}, M_{ntlb}) = 117.83 \cdot \text{kip} \cdot \text{ft}$$

Design flexure strength

$$m_c := \frac{M_n}{\Omega_f} = 70.56 \cdot \text{kip} \cdot \text{ft}$$

Check for flexural strength

$$\text{Check}_{mc} := \begin{cases} \frac{M_d}{m_c} & \text{if } m_c \geq M_d \\ \text{"Revise waler section"} & \text{if } m_c < M_d \end{cases}$$

$$\text{Check}_{mc} = 0.64$$

## Deflection Check

Limiting Deflection

$$L_{ld} := \frac{L_b}{360} = 0.33 \cdot \text{in}$$



Client IPC & MIMC Job Number 11215702 Sheet \_\_\_\_\_  
Project San Jacinto River Waste Pits Site Sheets By I.Goel Date 06/03/2022  
Subject Waler Section & Splice Connection Design Calculation Checked By S.Chilka Date 06/03/2022

Maximum deflection from SAP2000 analysis

$$L_{md} := 0.18\text{in}$$

Demand to Capacity Ratio

$$\text{Check}_d := \begin{cases} \frac{L_{md}}{L_{ld}} & \text{if } L_{ld} \geq L_{md} \\ \text{"Revise unbraced length"} & \text{if } L_{ld} < L_{md} \end{cases}$$

$$\text{Check}_d = 0.54$$

### Bolted Splice Plate Connection Design for Waler, Allowable Stress Design - AISC 360-16

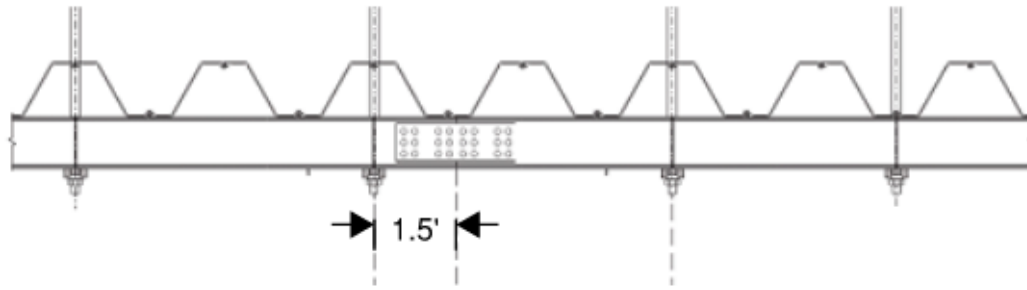

From SAP2000 analysis, point of zero moment in typical span for case 1 is ~1.2' and for case 2 is ~1.7' from tie rod anchorage. Point of splice connection for design is 1.5' from tie rod anchorage.

### Resultant Web Force at Point of Splice Connection

Bending moment demand at point of splice, from SAP2000 analysis

$$M_{sd} := 11\text{kip}\cdot\text{ft}$$

Horizontal force in web due to moment at point of splice

$$H_w := \frac{M_{sd} \cdot 4}{[d - [2 \cdot (k - 2t_c)]]} = 55.9\cdot\text{kip}$$



Client IPC & MIMC Job Number 11215702 Sheet \_\_\_\_\_  
 Project San Jacinto River Waste Pits Site Sheets By I.Goel Date 06/03/2022  
 Subject Waler Section & Splice Connection Design Calculation Checked By S.Chilka Date 06/03/2022

Resultant web force at point of splice connection  $V_r := \sqrt{Vd^2 + H_w^2} = 64.92 \cdot \text{kip}$

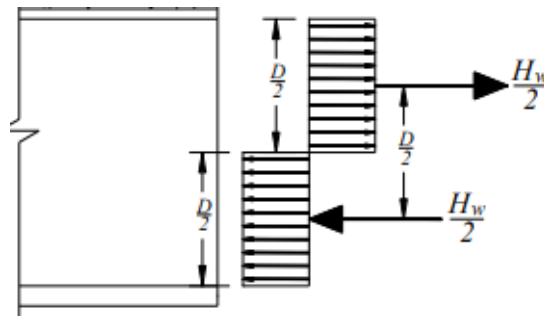

$$\text{Web Moment} = \frac{H_w \left( \frac{D}{2} \right)}{2}$$

$$H_w = \frac{\text{Web Moment}}{D/4}$$

### Factored shear resistance of bolts in shear

No of shear planes

$N_s := 1$

Section J3, Table J3.2

Using HDG Group A, A325 bolts

Nominal shear stress when threads are not excluded from shear planes

$F_{nv} := 54 \text{ksi}$

Taking 1.25" nominal diameter bolt

Bolt nominal diameter

$db := 1.25 \text{in}$

Nominal unthreaded body area of bolt

$A_b := 3.14 \cdot (db)^2 \cdot 0.25 = 1.23 \cdot \text{in}^2$

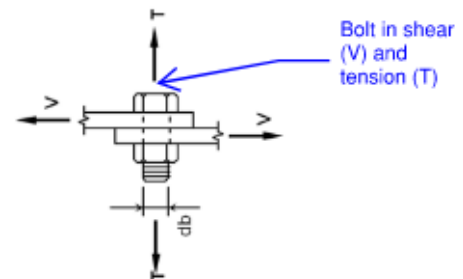



Client IPC & MIMC Job Number 11215702 Sheet \_\_\_\_\_  
 Project San Jacinto River Waste Pits Site Sheets By I.Goel Date 06/03/2022  
 Subject Waler Section & Splice Connection Design Calculation Checked By S.Chilka Date 06/03/2022

Nominal shear strength of bolt  $R_n := F_{nv} \cdot A_b \cdot N_s = 66.23 \cdot \text{kip}$

Overstrength factor  $\Omega_b := 2$

Allowable shear strength of bolt  $R_r := \frac{R_n}{\Omega_b} = 33.12 \cdot \text{kip}$

No of bolts required on each side of the web splice  $N_b := \frac{V_r}{R_r} = 1.96$

No of bolts provided on each side of the web splice  **$N_f := 6$**

No of bolt columns in connection pattern along the length of splice plate  **$N_r := 3$**

### Bolt Connection Pattern

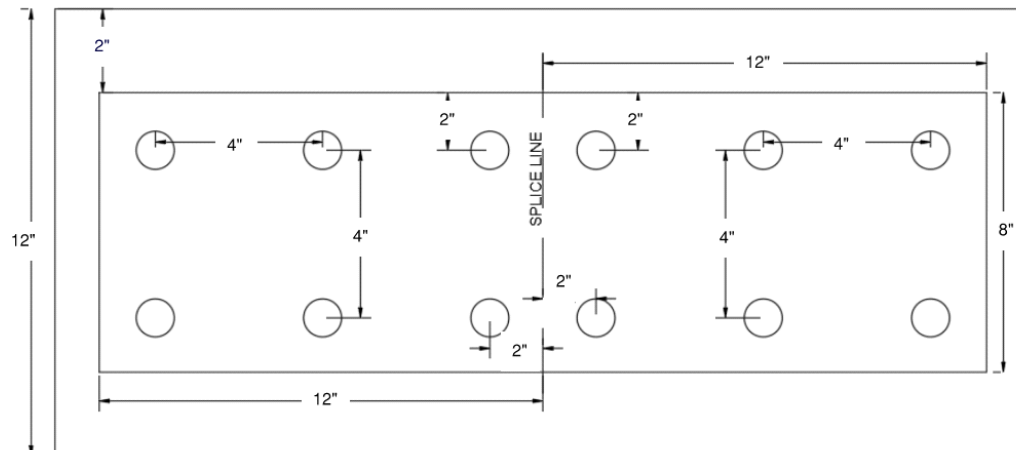

Table J3.3, for 1.25" bolt dia, standard hole dia is 1.375"

Hole diameter  **$dbh := 1.375 \text{in}$**



Client IPC & MIMC Job Number 11215702 Sheet \_\_\_\_\_  
Project San Jacinto River Waste Pits Site Sheets By I.Goel Date 06/03/2022  
Subject Waler Section & Splice Connection Design Calculation Checked By S.Chilka Date 06/03/2022

Minimum center to center spacing allowed b/w holes, Sec J3.3  $S_{min} := \frac{8 \cdot (db)}{3} = 3.33 \cdot \text{in}$

Minimum clear spacing allowed b/w holes, Sec J3.3  $S_{cmin} := db = 1.25 \cdot \text{in}$

Table J3.4, minimum edge distance allowed for 1.25" bolt dia  $S_{emin} := 1.625 \text{in}$

**Providing a splice plate of 24"X8", 0.75" thickness for the connection**

No of splice plates in the connection  $N_{sp} := 1$

**Eq. J4-3 and J4-4, strength of elements in shear**

Depth of splice plate  $d_{sp} := 8 \text{in}$

Thickness of splice plate  $T_{wsp} := 0.75 \text{in}$

Reduced thickness of splice plate - for accounting corrosion  $tw_{sp} := T_{wsp} - tc = 0.73 \cdot \text{in}$

Gross area subject to shear  $A_{gv} := d_{sp} \cdot tw_{sp} = 5.86 \cdot \text{in}^2$

Nominal shear yielding strength  $R_{nsy} := 0.6 \cdot F_y \cdot A_{gv} \cdot N_{sp} = 126.58 \cdot \text{kip}$

Overstrength factor  $\Omega_{spcy} := 1.5$



Client IPC & MIMC Job Number 11215702 Sheet \_\_\_\_\_  
Project San Jacinto River Waste Pits Site Sheets By I.Goel Date 06/03/2022  
Subject Waler Section & Splice Connection Design Calculation Checked By S.Chilka Date 06/03/2022

Allowable shear yielding strength  $R_{rsy} := \frac{R_{nsy}}{\Omega_{spsy}} = 84.38 \cdot \text{kip}$

Demand to Capacity Ratio 
$$\text{Checksy} := \begin{cases} \frac{V_d}{R_{rsy}} & \text{if } R_{rsy} \geq V_d \\ \text{"Revise splice plate"} & \text{if } R_{rsy} < V_d \end{cases}$$

$\text{Checksy} = 0.39$

Net area subject to shear  $A_{nv} := \left[ d_{sp} - \left( N_f \cdot \frac{d_{bh}}{N_r} \right) \right] \cdot t_{wsp} = 3.85 \cdot \text{in}^2$

Nominal shear rupture strength  $R_{nsr} := 0.6 \cdot F_u \cdot A_{nv} \cdot N_{sp} = 133.83 \cdot \text{kip}$

Overstrength factor  $\Omega_{spsr} := 2$

Allowable shear rupture strength  $R_{rsr} := \frac{R_{nsr}}{\Omega_{spsr}} = 66.91 \cdot \text{kip}$

Demand to Capacity ratio 
$$\text{Checksr} := \begin{cases} \frac{V_d}{R_{rsr}} & \text{if } R_{rsr} \geq V_d \\ \text{"Revise splice plate"} & \text{if } R_{rsr} < V_d \end{cases}$$

$\text{Checksr} = 0.49$



Client IPC & MIMC Job Number 11215702 Sheet \_\_\_\_\_  
Project San Jacinto River Waste Pits Site Sheets By I.Goel Date 06/03/2022  
Subject Waler Section & Splice Connection Design Calculation Checked By S.Chilka Date 06/03/2022

### Maximum spacing and edge distance - Section J3-5

Maximum edge distance

$$S_{\max} := \begin{cases} 12 \cdot \min(t_w, T_{wsp}) & \text{if } 12 \cdot \min(t_w, T_{wsp}) \leq 6 \text{ in} \\ 6 \text{ in} & \text{if } 12 \cdot \min(t_w, T_{wsp}) > 6 \text{ in} \end{cases} = 5.25 \cdot \text{in}$$

Maximum center to center longitudinal spacing  
allowed b/w holes

$$S_{\max} := \begin{cases} 24 \cdot \min(t_w, T_{wsp}) & \text{if } 24 \cdot \min(t_w, T_{wsp}) \leq 12 \text{ in} \\ 12 \text{ in} & \text{if } 24 \cdot \min(t_w, T_{wsp}) > 12 \text{ in} \end{cases} = 10.5 \cdot \text{in}$$

Distance of bolt from splice plate edge

$$S_{\text{prov}} := 2 \text{ in}$$

Distance of bolt from channel section flange  
inner edge

$$S_{\text{prov}} := S_{\text{prov}} + [(d - dsp) \cdot 0.5 - k] = 2.69 \cdot \text{in}$$

Spacing provided between bolts

$$S_{\text{prov}} := 4 \text{ in}$$

Check for bolt edge distance provided

$$S_{\text{check}} := \begin{cases} \text{"Okay"} & \text{if } S_{\min} \leq \max(S_{\text{prov}}, S_{\text{prov}}) \leq S_{\max} \\ \text{"Not Okay"} & \text{otherwise} \end{cases} = \text{"Okay"}$$

Check for spacing provided between bolts

$$S_{\text{check}} := \begin{cases} \text{"Okay"} & \text{if } (\max(S_{\min}, S_{\min} + dbh) \leq S_{\text{prov}} \leq S_{\max}) \\ \text{"Not Okay"} & \text{otherwise} \end{cases} = \text{"Okay"}$$



Client IPC & MIMC Job Number 11215702 Sheet \_\_\_\_\_  
 Project San Jacinto River Waste Pits Site Sheets By I.Goel Date 06/03/2022  
 Subject Waler Section & Splice Connection Design Calculation Checked By S.Chilka Date 06/03/2022

**Block Shear Rupture Check, Eq. J4-5**

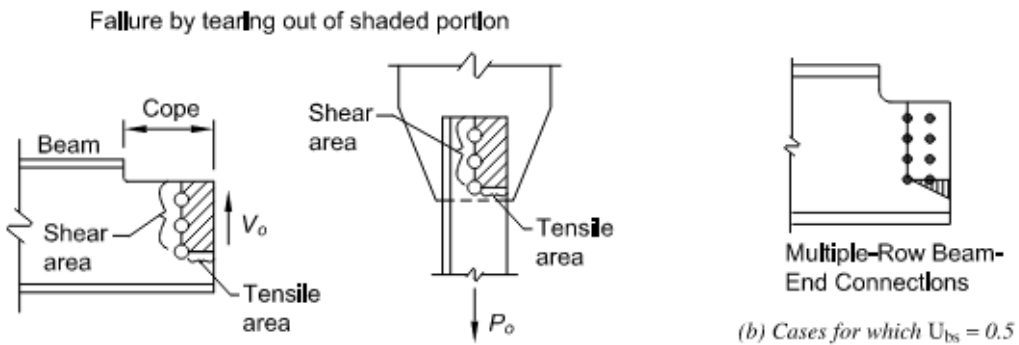

Fig. C-J4.1. Failure surface for block shear rupture limit state.

No of bolts in the outermost edge of the connection pattern which is in tension

**Nbr := 3**

Net Area resisting the tensile stress

$$A_{nt} := N_{sp} \cdot [S_{p_{rov}} + (N_{br} - 1)S_{p_{rov}} - [d_{bh} \cdot (N_{br} - 0.5)]] \cdot t_{wsp} = 4.81 \cdot \text{in}^2$$

Net Area resisting the shear stress

$$A_{vn} := N_{sp} \cdot \left[ d_{sp} - S_{p_{rov}} - \left[ \left( \frac{N_f}{N_r} \right) - 0.5 \right] \cdot d_{bh} \right] \cdot t_{wsp} = 2.88 \cdot \text{in}^2$$

Gross area resisting the shear stress

$$A_{gv} := N_{sp} \cdot (d_{sp} - S_{p_{rov}}) \cdot t_{wsp} = 4.39 \cdot \text{in}^2$$

Nominal block shear strength

$$U_{bs} := 0.5$$

$$R_{bs} := [(0.6 \cdot F_u \cdot A_{vn}) + (U_{bs} \cdot F_u \cdot A_{nt})] = 239.77 \cdot \text{kip}$$

$$R_{nbs} := \begin{cases} R_{bs} & \text{if } R_{bs} \leq [(0.6 \cdot F_y \cdot A_{gv}) + (U_{bs} \cdot F_u \cdot A_{nt})] \\ [(0.6 \cdot F_y \cdot A_{gv}) + (U_{bs} \cdot F_u \cdot A_{nt})] & \text{if } R_{bs} > [(0.6 \cdot F_y \cdot A_{gv}) + (U_{bs} \cdot F_u \cdot A_{nt})] \end{cases} = 234.34 \cdot \text{kip}$$



Client IPC & MIMC Job Number 11215702 Sheet \_\_\_\_\_  
Project San Jacinto River Waste Pits Site Sheets By I.Goel Date 06/03/2022  
Subject Waler Section & Splice Connection Design Calculation Checked By S.Chilka Date 06/03/2022

Overstrength Factor

$$\Omega_{bs} := 2$$

Allowable block shear strength

$$R_{rbs} := \frac{R_{nbs}}{\Omega_{bs}} = 117.17 \cdot \text{kip}$$

Demand to Capacity Ratio

$$\text{Check}_{bs} := \begin{cases} \frac{V_d}{R_{rbs}} & \text{if } R_{rbs} \geq V_d \\ \text{"Revise splice plate"} & \text{if } R_{rbs} < V_d \end{cases}$$

$$\text{Check}_{bs} = 0.28$$

#### **Bearing Resistance Check, Eq. J3-6a**

Nominal bearing strength at bolt holes

$$R_{nb} := 2.4 \cdot (db) \cdot t_{wsp} \cdot F_u \cdot N_f = 764.73 \cdot \text{kip}$$

Overstrength Factor

$$\Omega_{bh} := 2$$

Allowable bearing strength at bolt holes

$$R_{rb} := \frac{R_{nb}}{\Omega_{bh}} = 382.36 \cdot \text{kip}$$

Demand to Capacity Ratio

$$\text{Check}_{bh} := \begin{cases} \frac{V_r}{R_{rb}} & \text{if } R_{rb} \geq V_r \\ \text{"Revise splice plate or bolts"} & \text{if } R_{rb} < V_r \end{cases} = 0.17$$

#### **Tearout Resistance Check, Eq. J3-6c**

$l_c$  for edge bolts

$$l_{co} := \text{Seprov} - \left( \frac{dbh}{2} \right) = 1.31 \cdot \text{in}$$



Client IPC & MIMC Job Number 11215702 Sheet \_\_\_\_\_  
Project San Jacinto River Waste Pits Site Sheets By I.Goel Date 06/03/2022  
Subject Waler Section & Splice Connection Design Calculation Checked By S.Chilka Date 06/03/2022

lc for inner bolts

$$l_{ci} := \text{Sprov} - \text{dbh} = 2.63 \cdot \text{in}$$

Inner bolts on each side of splice

$$N_i := 0$$

For edge bolts, nominal tearout strength at bolt holes

$$R_{nto} := 1.2 \cdot \text{twsp} \cdot F_u \cdot l_{co} \cdot (N_f - N_i) = 401.48 \cdot \text{kip}$$

For inner bolts, nominal tearout strength at bolt holes

$$R_{nti} := 1.2 \cdot \text{twsp} \cdot F_u \cdot l_{ci} \cdot N_i = 0 \cdot \text{kip}$$

Total nominal tearout strength at bolt holes

$$R_{nt} := R_{nto} + R_{nti} = 401.48 \cdot \text{kip}$$

Overstrength factor

$$\Omega_{bt} := 2$$

Allowable tearout strength at bolt holes

$$R_{rt} := \frac{R_{nt}}{\Omega_{bt}} = 200.74 \cdot \text{kip}$$

Demand to Capacity Ratio

$$\text{Checkth} := \begin{cases} \frac{V_r}{R_{rt}} & \text{if } R_{rt} \geq V_r \\ \text{"Revise splice plate or bolts"} & \text{if } R_{rt} < V_r \end{cases} = 0.32$$

#### Slip Resistance Check, Eq. J3-4

For class A surfaces

$$\mu := 0.3$$

$$D_u := 1.13$$

Minimum bolt pretension, Table J3.1 for Group A, A325 bolts

$$T_b := 81 \text{kip}$$



Client IPC & MIMC Job Number 11215702 Sheet \_\_\_\_\_  
Project San Jacinto River Waste Pits Site Sheets By I.Goel Date 06/03/2022  
Subject Waler Section & Splice Connection Design Calculation Checked By S.Chilka Date 06/03/2022

$$hf := 1$$

Nominal slip resistance of bolts

$$Rsr := Nf \cdot Ns \cdot \mu \cdot Du \cdot Tb \cdot hf = 164.75 \cdot \text{kip}$$

Overstrength Factor

$$\Omega_{sr} := 1.5$$

Allowable slip resistance of bolts

$$Rrslr := \frac{Rsr}{\Omega_{sr}} = 109.84 \cdot \text{kip}$$

Demand to Capacity Ratio

$$\text{Checkslr} := \begin{cases} \frac{V_r}{Rrslr} & \text{if } Rrslr \geq V_r \\ \text{"Revise bolts size"} & \text{if } Rrslr < V_r \end{cases} = 0.59$$

### Design Summary

**Provide rectangular splice plate of 24"X8",0.75" thickness. On each side of web splice bolted plate connection, provide 6 - 1.25" dia HDG Group A - A325 bolts.**



Client IPC & MIMC Job Number 11215702 Sheet \_\_\_\_\_  
 Project San Jacinto River Waste Pits Site Sheets By I.Goel Date 06/03/2022  
 Subject Waler Section & Splice Connection Design Calculation Checked By S.Chilka Date 06/03/2022

## Analysis Demand Load on Waler - Sec C2

Tie Rod Tension Demand Load from Analysis

$$T_{roda} := 178.4 \text{ kip}$$

Reduced to 106 kips  
 July 2024  
 This calculation is still okay.

Tie Rod Spacing

$$S_{roda} := 6 \text{ ft}$$

The tie rod spacing assumed in analysis results in large demand loads and section size for waler. To optimize section selection, tie rods will be closely spaced. Closely spaced tie rods will result in lower demand loads.

Revised Tie Rod Spacing

$$S_{rod} := 5 \text{ ft}$$

Revised Tie Rod Tension Demand

$$T_{rod} := T_{roda} \cdot \frac{S_{rod}}{S_{roda}} = 148.67 \cdot \text{kip}$$

Demand Load on waler

$$w_{dl} := \frac{T_{rod}}{S_{rod}} = 29.73 \cdot \frac{\text{kip}}{\text{ft}}$$

## Demand Load on Waler to safeguard against progressive failure

In certain situations, progressive collapse of the structure may be a consequence of an extreme condition ie. failure of a tie rod. The walling to the main wall will need to be checked to ensure that it will not collapse if the span between tie rods doubles following the loss of a tie rod.

SAP2000 analysis is used to calculate the bending moment and shear force demand on the waler for both the cases. Case 1 - without failure of a tie rod and, Case 2 - with failure of a tie rod.

For Case 1 - Continuous beam with four equal spans of length  $S_{rod}$  is analyzed  
 For Case 2 - Continuous beam with three spans of length  $S_{rod} - 2S_{rod} - S_{rod}$  is analyzed

Waler Design is governed by the demands from Case 2



Client IPC & MIMC Job Number 11215702 Sheet \_\_\_\_\_  
Project San Jacinto River Waste Pits Site Sheets By I.Goel Date 06/03/2022  
Subject Waler Section & Splice Connection Design Calculation Checked By S.Chilka Date 06/03/2022

### Bending Moment Diagram - Case 1

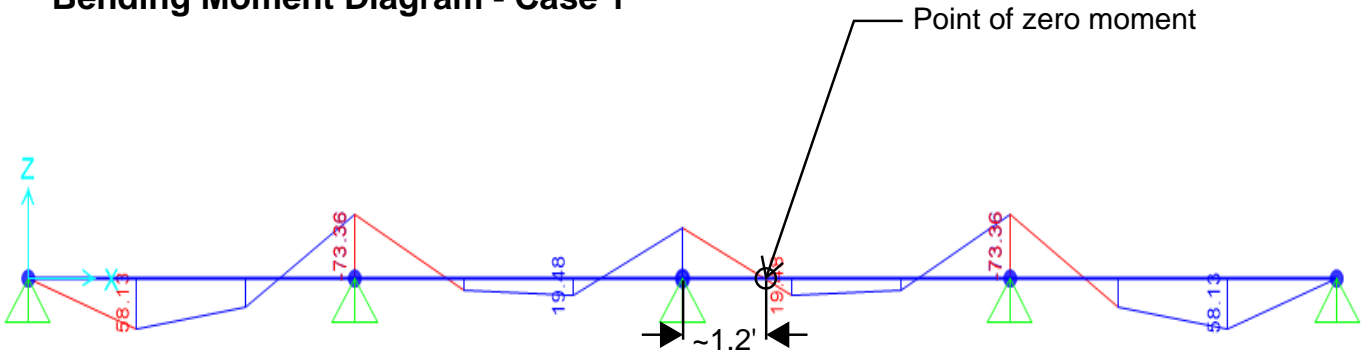

Bending Moment demand from SAP2000 -  $M_{dsap} = 73.4 \text{ Kip-ft}$

### Shear Force Diagram - Case 1

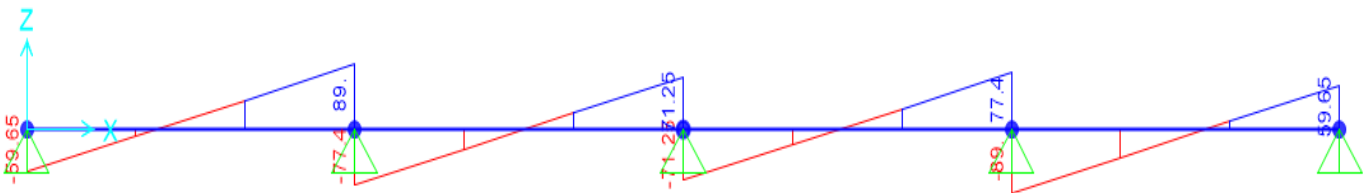

Shear Force demand from SAP2000 -  $V_{dsap} = 89 \text{ Kip}$





Client IPC & MIMC Job Number 11215702 Sheet \_\_\_\_\_  
Project San Jacinto River Waste Pits Site Sheets By I.Goel Date 06/03/2022  
Subject Waler Section & Splice Connection Design Calculation Checked By S.Chilka Date 06/03/2022

## Waler Cross-Section

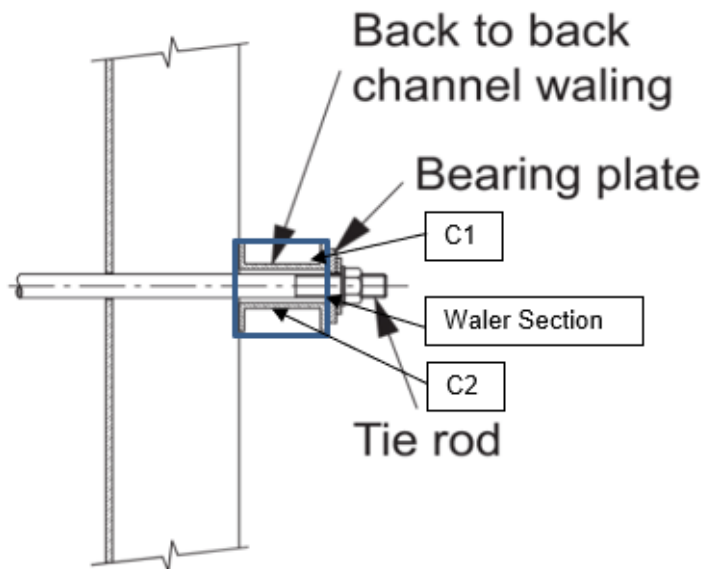

Waler is made of two channel sections C1 and C2

## Design of corroded waler section, AISC 360-16

Bending moment demand on waler from SAP2000

$$M_{dsap} := 203.26 \text{ kip}\cdot\text{ft}$$

Shear force demand on waler from SAP2000

$$V_{dsap} := 149 \cdot \text{kip}$$

Bending moment demand on C1 or C2

$$M_d := \frac{M_{dsap}}{2} = 101.63 \cdot \text{kip}\cdot\text{ft}$$

Shear force demand on C1 or C2

$$V_d := \frac{V_{dsap}}{2} = 74.5 \cdot \text{kip}$$

Steel yield stress

$$F_y := 36 \text{ ksi}$$



Client IPC & MIMC Job Number 11215702 Sheet \_\_\_\_\_  
Project San Jacinto River Waste Pits Site Sheets By I.Goel Date 06/03/2022  
Subject Waler Section & Splice Connection Design Calculation Checked By S.Chilka Date 06/03/2022

Steel tensile stress  $F_u := 58\text{ksi}$

Modulus of Elasticity of steel  $E := 29000\text{ksi}$

Sacrificial thickness - for accounting corrosion  $t_c := 0.0175\text{in}$  Refer Basis of Design report

### Channel Section Dimensional Parameters (MC18X45.8)

Depth  $d := 18\text{in}$

Web thickness  $t_w := 0.5\text{in}$

Flange thickness  $t_f := 0.625\text{in}$

Flange width  $b_f := 4\text{in}$

Distance  $k := 1.4375\text{in}$

### Corroded Channel Section Dimensional Parameters (MC18X45.8)

Web thickness  $t_{wc} := t_w - 2t_c = 0.47\text{in}$

Flange thickness  $t_{fc} := t_f - 2t_c = 0.59\text{in}$

### Sectional Properties of Corroded Section

Plastic modulus about x axis

$$Z_x := \left[ (b_f) \cdot \frac{(d)^2}{4} \right] - \left[ [(b_f) - (t_{wc})] \cdot \frac{[(d) - [2 \cdot (t_{fc})]]^2}{4} \right] = 73.98 \cdot \text{in}^3$$



Client IPC & MIMC Job Number 11215702 Sheet \_\_\_\_\_  
Project San Jacinto River Waste Pits Site Sheets By I.Goel Date 06/03/2022  
Subject Waler Section & Splice Connection Design Calculation Checked By S.Chilka Date 06/03/2022

Elastic modulus about x axis

$$S_x := \frac{\left[ (bf) \cdot \frac{(d)^3}{12} \right] - \left[ [(bf) - (twc)] \cdot \frac{[(d) - [2 \cdot (tfc)]]^3}{12} \right]}{(d) \cdot 0.5} = 60.24 \cdot \text{in}^3$$

Torsion constant

$$J_w := \frac{\left[ 2 \cdot (bf) \cdot (tfc)^3 \right] + \left[ [(d) - (tfc)] \cdot (twc)^3 \right]}{3} = 1.13 \cdot \text{in}^4$$

Moment of Inertia about external edge  
of web parallel to y axis

$$I_{y0} := \left[ [(d) - [2 \cdot (tfc)]] \cdot \frac{(twc)^3}{3} \right] + \left[ (bf)^3 \cdot (tfc) \cdot \frac{2}{3} \right] = 25.74 \cdot \text{in}^4$$

Cross sectional area

$$A_c := [2 \cdot (bf) \cdot (tfc)] + [(d) - [2 \cdot (tfc)]] \cdot (twc) = 12.54 \cdot \text{in}^2$$

Distance of centroid from external edge  
of web

$$x_c := \frac{\left[ [(d) - [2 \cdot (tfc)]] \cdot \frac{(twc)^2}{2} \right] + \left[ (bf)^2 \cdot (tfc) \right]}{A_c} = 0.9 \cdot \text{in}$$

Moment of inertia about y axis

$$I_y := I_{y0} - (A_c \cdot x_c^2) = 15.63 \cdot \text{in}^4$$



Client IPC & MIMC Job Number 11215702 Sheet \_\_\_\_\_  
Project San Jacinto River Waste Pits Site Sheets By I.Goel Date 06/03/2022  
Subject Waler Section & Splice Connection Design Calculation Checked By S.Chilka Date 06/03/2022

Distance between flange centroids  $h_o := (d) - (tfc) = 17.41 \cdot \text{in}$

Warping torsional constant

$$C_w := \frac{[(tfc) \cdot (bf)^3 \cdot [(d) - (tfc)]^2] \cdot [[3 \cdot (bf) \cdot (tfc)] + [2 \cdot (twc) \cdot [(d) - (tfc)]]]}{12 \cdot [[6 \cdot (bf) \cdot (tfc)] + [(twc) \cdot [(d) - (tfc)]]]}$$

$$C_w = 997.31 \cdot \text{in}^6$$

radius of gyration about y axis  $r_y := \sqrt{\frac{I_y}{A_c}} = 1.12 \cdot \text{in}$

Overstrength factor for flexure  $\Omega_f := 1.67$

Overstrength factor for shear  $\Omega_v := 1.67$

## Classification of sections for local buckling - Section B4.1

### Classification of flanges in flexure - Table B4.1b (case 10)

Width - to - Thickness Ratio for flange  $a_f := \frac{bf}{tfc} = 6.78$

Limiting width to thickness ratio for compact flange section about major/minor axis  $\lambda_{cf} := 0.38 \cdot \sqrt{\frac{E}{F_y}} = 10.79$

Limiting width to thickness ratio for non compact flange section about major/minor axis  $\lambda_{nf} := 1 \cdot \sqrt{\frac{E}{F_y}} = 28.38$

### Classification of web in flexure - Table B4.1b (case 15)

Width - to - Thickness Ratio for web  $a_w := \frac{(d) - [2 \cdot (k - 2tc)]}{twc} = 32.68$



Client IPC & MIMC Job Number 11215702 Sheet \_\_\_\_\_  
 Project San Jacinto River Waste Pits Site Sheets By I.Goel Date 06/03/2022  
 Subject Waler Section & Splice Connection Design Calculation Checked By S.Chilka Date 06/03/2022

Limiting width to thickness ratio for compact web section about major/minor axis  $\lambda_{cw} := 3.76 \cdot \sqrt{\frac{E}{F_y}} = 106.72$

Limiting width to thickness ratio for non compact web section about major/minor axis  $\lambda_{nw} := 5.7 \sqrt{\frac{E}{F_y}} = 161.78$

$cn_{ff} := \begin{cases} \text{"Compact flange"} & \text{if } a_f \leq \lambda_{cf} \\ \text{"Non compact flange"} & \text{if } \lambda_{cf} \leq a_f \leq \lambda_{nf} \\ \text{"Slender flange"} & \text{otherwise} \end{cases} = \text{"Compact flange"}$

$cn_{wf} := \begin{cases} \text{"Compact web"} & \text{if } a_w \leq \lambda_{cw} \\ \text{"Non compact web"} & \text{if } \lambda_{cw} \leq a_w \leq \lambda_{nw} \\ \text{"Slender flange web"} & \text{otherwise} \end{cases} = \text{"Compact web"}$

### Allowable Stress Shear Design - Chapter G

Web area  $A_w := (d) \cdot (twc) = 8.37 \cdot \text{in}^2$

Web plate buckling coefficient  $K_v := 5.34$

$$r := 1.1 \cdot \left( K_v \cdot \frac{E}{F_y} \right)^{\frac{1}{2}} = 72.15$$

$$r1 := \frac{(d) - [2 \cdot (tfc)]}{twc} = 36.17$$

Web shear coefficient, Eq G2-3 and Eq G2-4

$$C_{v1} := \begin{cases} 1 & \text{if } r \geq r1 \\ \frac{r}{r1} & \text{if } r < r1 \end{cases}$$



Client IPC & MIMC Job Number 11215702 Sheet \_\_\_\_\_  
Project San Jacinto River Waste Pits Site Sheets By I.Goel Date 06/03/2022  
Subject Waler Section & Splice Connection Design Calculation Checked By S.Chilka Date 06/03/2022

$$Cv1 = 1$$

Nominal shear strength, Eq G2-1

$$Vn := 0.6 \cdot Cv1 \cdot Aw \cdot Fy = 180.79 \cdot \text{kip}$$

Allowable shear strength

$$vc := \frac{Vn}{\Omega_v} = 108.26 \cdot \text{kip}$$

Check for shear strength

$$\text{Checkvc} := \begin{cases} \frac{Vd}{vc} & \text{if } vc \geq Vd \\ \text{"Revise waler section"} & \text{if } vc < Vd \end{cases}$$

$$\text{Checkvc} = 0.69$$

## Allowable Stress Flexure design about major axis - Chapter F

### Yielding - Section F2.1

Nominal flexural strength for yielding, Eq F2-1

$$Mnyld := Fy \cdot Zx = 221.93 \cdot \text{kip} \cdot \text{ft}$$

### Lateral Torsional Buckling - Section F2.2

Unbraced length

$$Lb := S_{rod} \cdot 2 = 120 \cdot \text{in}$$

Limiting unbraced length for yielding Eq F2-5

$$Lp := 1.76 \cdot ry \cdot \sqrt{\frac{E}{Fy}} = 55.77 \cdot \text{in}$$

Eq F2-8b

$$cf := \left( \frac{ho}{2} \right) \cdot \sqrt{\frac{Iy}{Cw}} = 1.09$$

Eq F2-7

$$rts := \sqrt{\frac{\sqrt{Iy \cdot Cw}}{Sx}} = 1.44 \cdot \text{in}$$



Client IPC & MIMC Job Number 11215702 Sheet \_\_\_\_\_  
Project San Jacinto River Waste Pits Site Sheets By I.Goel Date 06/03/2022  
Subject Waler Section & Splice Connection Design Calculation Checked By S.Chilka Date 06/03/2022

Eq F2-6

$$L_r := 1.95 \cdot r_{ts} \cdot \frac{E \cdot \sqrt{\left(\frac{J \cdot c_f}{S_x \cdot h_o}\right) + \sqrt{\left(\frac{J \cdot c_f}{S_x \cdot h_o}\right)^2 + \left[6.76 \cdot \left(0.7 \cdot \frac{F_y}{E}\right)^2\right]}}{(0.7 \cdot F_y)} = 197.09 \cdot \text{in}$$

**From SAP2000 analysis, for calculation of  $C_b$  ( $L_p < L_b \leq L_r$ )**

Moment at quarter point of unbraced segment  $M_a := 64.3 \text{ kip} \cdot \text{ft}$

Moment at center line of unbraced segment  $M_b := 153.5 \text{ kip} \cdot \text{ft}$

Moment at three quarter point of unbraced segment  $M_c := 64.3 \text{ kip} \cdot \text{ft}$

Maximum moment in unbraced segment  $M_{abs} := 203.3 \text{ kip} \cdot \text{ft}$

Plastic moment capacity  $M_p := M_{nyld}$

Lateral torsional buckling modification factor, Eq F1-1

$$C_b := 12.5 \cdot \frac{M_{abs}}{[(2.5 \cdot M_{abs}) + (3 \cdot M_a) + (4 \cdot M_b) + (3 \cdot M_c)]} = 1.69$$

Nominal flexural strength for lateral torsional buckling - Eq F2-2

$$M_{nlb} := C_b \cdot \left[ M_p - (M_p - 0.7 \cdot F_y \cdot S_x) \cdot \frac{(L_b - L_p)}{(L_r - L_p)} \right]$$

$$M_{nlb} = 300.9 \cdot \text{kip} \cdot \text{ft}$$



Client IPC & MIMC Job Number 11215702 Sheet \_\_\_\_\_  
Project San Jacinto River Waste Pits Site Sheets By I.Goel Date 06/03/2022  
Subject Waler Section & Splice Connection Design Calculation Checked By S.Chilka Date 06/03/2022

Nominal flexural strength

$$M_n := \min(M_{nyld}, M_{nltb}) = 221.93 \cdot \text{kip} \cdot \text{ft}$$

Design flexure strength

$$m_c := \frac{M_n}{\Omega_f} = 132.89 \cdot \text{kip} \cdot \text{ft}$$

Check for flexural strength

$$\text{Check}_{m_c} := \begin{cases} \frac{M_d}{m_c} & \text{if } m_c \geq M_d \\ \text{"Revise waler section"} & \text{if } m_c < M_d \end{cases}$$

$$\text{Check}_{m_c} = 0.76$$

## Deflection Check

Limiting Deflection

$$L_{ld} := \frac{L_b}{360} = 0.33 \cdot \text{in}$$

Maximum deflection from SAP2000 analysis

$$L_{md} := 0.25 \cdot \text{in}$$

Demand to Capacity Ratio

$$\text{Check}_d := \begin{cases} \frac{L_{md}}{L_{ld}} & \text{if } L_{ld} \geq L_{md} \\ \text{"Revise unbraced length"} & \text{if } L_{ld} < L_{md} \end{cases}$$

$$\text{Check}_d = 0.75$$



Client IPC & MIMC Job Number 11215702 Sheet \_\_\_\_\_  
 Project San Jacinto River Waste Pits Site Sheets By I.Goel Date 06/03/2022  
 Subject Waler Section & Splice Connection Design Calculation Checked By S.Chilka Date 06/03/2022

## Bolted Splice Plate Connection Design for Waler, Allowable Stress Design - AISC 360-16

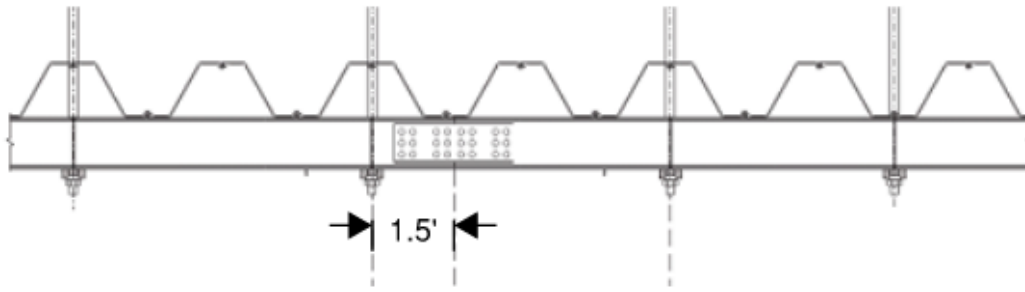

From SAP2000 analysis, point of zero moment in typical span for case 1 is ~1.2' and for case 2 is ~1.7' from tie rod anchorage. Point of splice connection for design is 1.5' from tie rod anchorage.

### Resultant Web Force at Point of Splice Connection

Bending moment demand at point of splice, from SAP2000 analysis

$$M_{sd} := 24.88 \text{ kip}\cdot\text{ft}$$

Horizontal force in web due to moment at point of splice

$$H_w := \frac{M_{sd} \cdot 4}{[d - [2 \cdot (k - 2tc)]]} = 78.59 \cdot \text{kip}$$

Resultant web force at point of splice connection

$$V_r := \sqrt{V_d^2 + H_w^2} = 108.29 \cdot \text{kip}$$

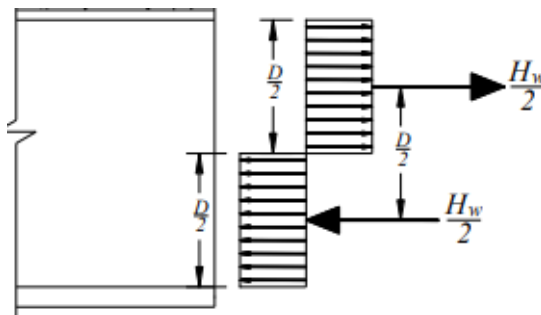

$$\text{Web Moment} = \frac{H_w}{2} \left( \frac{D}{2} \right)$$

$$H_w = \frac{\text{Web Moment}}{D/4}$$



Client IPC & MIMC Job Number 11215702 Sheet \_\_\_\_\_  
Project San Jacinto River Waste Pits Site Sheets By I.Goel Date 06/03/2022  
Subject Waler Section & Splice Connection Design Calculation Checked By S.Chilka Date 06/03/2022

### Factored shear resistance of bolts in shear

No of shear planes

$$N_s := 1$$

Section J3, Table J3.2

Using HDG Group A, A325 bolts

Nominal shear stress when threads are not excluded from shear planes

$$F_{nv} := 54 \text{ ksi}$$

Taking 1.375" nominal diameter bolt

Bolt nominal diameter

$$d_b := 1.375 \text{ in}$$

Nominal unthreaded body area of bolt

$$A_b := 3.14 \cdot (d_b)^2 \cdot 0.25 = 1.48 \cdot \text{in}^2$$

Nominal shear strength of bolt

$$R_n := F_{nv} \cdot A_b \cdot N_s = 80.14 \cdot \text{kip}$$

Overstrength factor

$$\Omega_b := 2$$

Allowable shear strength of bolt

$$R_r := \frac{R_n}{\Omega_b} = 40.07 \cdot \text{kip}$$

No of bolts required on each side of the web splice

$$N_b := \frac{V_r}{R_r} = 2.7$$

No of bolts provided on each side of the web splice

$$N_f := 6$$

No of bolt columns in connection pattern along the length of splice plate

$$N_r := 3$$

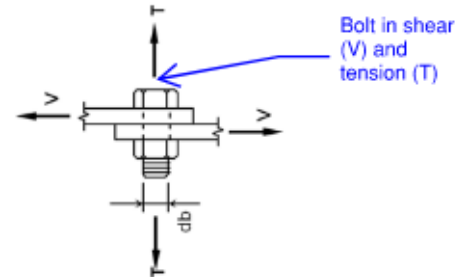



Client IPC & MIMC Job Number 11215702 Sheet \_\_\_\_\_  
 Project San Jacinto River Waste Pits Site Sheets By I.Goel Date 06/03/2022  
 Subject Waler Section & Splice Connection Design Calculation Checked By S.Chilka Date 06/03/2022

### Bolt Connection Pattern

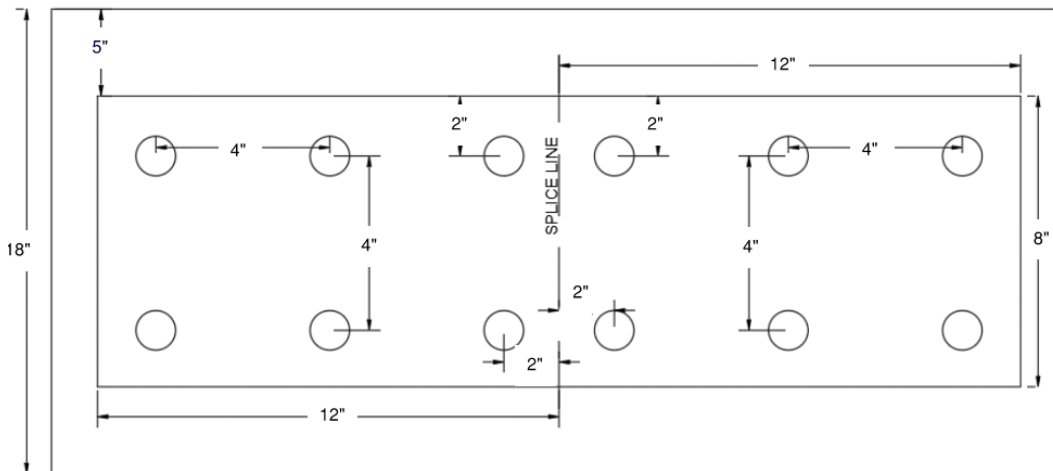

**Table J3.3, for 1.375" bolt dia, standard hole dia is 1.5"**

Hole diameter dbh := 1.5in

Minimum center to center spacing allowed b/w holes, Sec J3.3  $S_{min} := \frac{8 \cdot (db)}{3} = 3.67 \cdot in$

Minimum clear spacing allowed b/w holes, Sec J3.3  $S_{cmin} := db = 1.38 \cdot in$

Table J3.4, minimum edge distance allowed for 1.375" bolt dia Semin := 1.72in

### Providing a splice plate of 24"X8", 1.25" thickness for the connection

No of splice plates in the connection  $N_{sp} := 1$



Client IPC & MIMC Job Number 11215702 Sheet \_\_\_\_\_  
Project San Jacinto River Waste Pits Site Sheets By I.Goel Date 06/03/2022  
Subject Waler Section & Splice Connection Design Calculation Checked By S.Chilka Date 06/03/2022

**Eq. J4-3 and J4-4, strength of elements in shear**

Depth of splice plate  $d_{sp} := 8 \text{ in}$

Thickness of splice plate  $T_{wsp} := 1.25 \text{ in}$

Reduced thickness of splice plate - for accounting corrosion  $tw_{sp} := T_{wsp} - t_c = 1.23 \cdot \text{in}$

Gross area subject to shear  $A_{gv} := d_{sp} \cdot tw_{sp} = 9.86 \cdot \text{in}^2$

Nominal shear yielding strength  $R_{nsy} := 0.6 \cdot F_y \cdot A_{gv} \cdot N_{sp} = 212.98 \cdot \text{kip}$

Overstrength factor  $\Omega_{sp_{sy}} := 1.5$

Allowable shear yielding strength  $R_{rsy} := \frac{R_{nsy}}{\Omega_{sp_{sy}}} = 141.98 \cdot \text{kip}$

Demand to Capacity Ratio  $\text{Checksy} := \begin{cases} \frac{V_d}{R_{rsy}} & \text{if } R_{rsy} \geq V_d \\ \text{"Revise splice plate"} & \text{if } R_{rsy} < V_d \end{cases}$

$\text{Checksy} = 0.52$

Net area subject to shear  $A_{nv} := \left[ d_{sp} - \left( N_f \cdot \frac{db_h}{N_r} \right) \right] \cdot tw_{sp} = 6.16 \cdot \text{in}^2$



Client IPC & MIMC Job Number 11215702 Sheet \_\_\_\_\_  
Project San Jacinto River Waste Pits Site Sheets By I.Goel Date 06/03/2022  
Subject Waler Section & Splice Connection Design Calculation Checked By S.Chilka Date 06/03/2022

Nominal shear rupture strength  $R_{nsr} := 0.6 \cdot F_u \cdot A_{nv} \cdot N_{sp} = 214.45 \cdot \text{kip}$

Overstrength factor  $\Omega_{spsr} := 2$

Allowable shear rupture strength  $R_{rsr} := \frac{R_{nsr}}{\Omega_{spsr}} = 107.23 \cdot \text{kip}$

Demand to Capacity ratio  $\text{Checksr} := \begin{cases} \frac{V_d}{R_{rsr}} & \text{if } R_{rsr} \geq V_d \\ \text{"Revise splice plate"} & \text{if } R_{rsr} < V_d \end{cases}$

$\text{Checksr} = 0.69$

### Maximum spacing and edge distance - Section J3-5

Maximum edge distance

$$S_{\text{max}} := \begin{cases} 12 \cdot \min(t_w, T_{\text{wsp}}) & \text{if } 12 \cdot \min(t_w, T_{\text{wsp}}) \leq 6 \text{ in} \\ 6 \text{ in} & \text{if } 12 \cdot \min(t_w, T_{\text{wsp}}) > 6 \text{ in} \end{cases} = 6 \cdot \text{in}$$

Maximum center to center longitudinal spacing  
allowed b/w holes

$$S_{\text{max}} := \begin{cases} 24 \cdot \min(t_w, T_{\text{wsp}}) & \text{if } 24 \cdot \min(t_w, T_{\text{wsp}}) \leq 12 \text{ in} \\ 12 \text{ in} & \text{if } 24 \cdot \min(t_w, T_{\text{wsp}}) > 12 \text{ in} \end{cases} = 12 \cdot \text{in}$$

Distance of bolt from splice plate edge  $\text{Seprov} := 2 \text{ in}$



Client IPC & MIMC Job Number 11215702 Sheet \_\_\_\_\_  
 Project San Jacinto River Waste Pits Site Sheets By I.Goel Date 06/03/2022  
 Subject Waler Section & Splice Connection Design Calculation Checked By S.Chilka Date 06/03/2022

Distance of bolt from channel section flange  
inner edge

$$Se_{prov} := Se_{prov} + [(d - dsp) \cdot 0.5 - k] = 5.56 \text{ in}$$

Spacing provided between bolts

$$S_{prov} := 4 \text{ in}$$

Check for bolt edge distance provided

$$Se_{check} := \begin{cases} \text{"Okay"} & \text{if } S_{min} \leq \max(Se_{prov}, S_{prov}) \leq S_{max} \\ \text{"Not Okay"} & \text{otherwise} \end{cases} = \text{"Okay"}$$

Check for spacing provided between bolts

$$S_{check} := \begin{cases} \text{"Okay"} & \text{if } (\max(S_{min}, S_{min} + dbh) \leq S_{prov} \leq S_{max}) \\ \text{"Not Okay"} & \text{otherwise} \end{cases} = \text{"Okay"}$$

**Block Shear Rupture Check, Eq. J4-5**

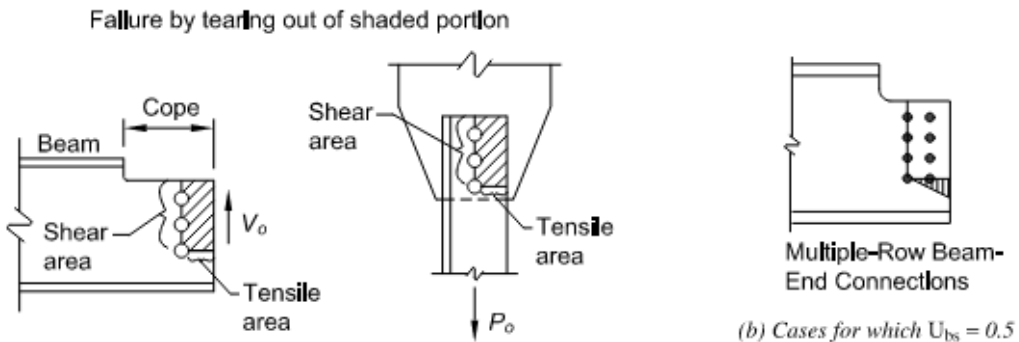

Fig. C-J4.1. Failure surface for block shear rupture limit state.

No of bolts in the outermost edge of the  
connection pattern which is in tension

$$N_{br} := 3$$



Client IPC & MIMC Job Number 11215702 Sheet \_\_\_\_\_  
Project San Jacinto River Waste Pits Site Sheets By I.Goel Date 06/03/2022  
Subject Waler Section & Splice Connection Design Calculation Checked By S.Chilka Date 06/03/2022

Net Area resisting the tensile stress

$$A_{nt} := N_{sp} \cdot [S_{eprov} + (N_{br} - 1)S_{p prov} - [d_{bh} \cdot (N_{br} - 0.5)]] \cdot t_{wsp} = 7.7 \cdot \text{in}^2$$

Net Area resisting the shear stress

$$A_{vn} := N_{sp} \cdot \left[ d_{sp} - S_{eprov} - \left[ \left[ \left( \frac{N_f}{N_r} \right) - 0.5 \right] \cdot d_{bh} \right] \right] \cdot t_{wsp} = 4.62 \cdot \text{in}^2$$

Gross area resisting the shear stress

$$A_{vg} := N_{sp} \cdot (d_{sp} - S_{eprov}) \cdot t_{wsp} = 7.39 \cdot \text{in}^2$$

Nominal block shear strength

$$U_{bs} := 0.5$$

$$R_{bs} := [(0.6 \cdot F_u \cdot A_{vn}) + (U_{bs} \cdot F_u \cdot A_{nt})] = 384.23 \cdot \text{kip}$$

$$R_{nbs} := \begin{cases} R_{bs} & \text{if } R_{bs} \leq [(0.6 \cdot F_y \cdot A_{vg}) + (U_{bs} \cdot F_u \cdot A_{nt})] \\ [(0.6 \cdot F_y \cdot A_{vg}) + (U_{bs} \cdot F_u \cdot A_{nt})] & \text{if } R_{bs} > [(0.6 \cdot F_y \cdot A_{vg}) + (U_{bs} \cdot F_u \cdot A_{nt})] \end{cases} = 383.12 \cdot \text{kip}$$

Overstrength Factor

$$\Omega_{bs} := 2$$

Allowable block shear strength

$$R_{rbs} := \frac{R_{nbs}}{\Omega_{bs}} = 191.56 \cdot \text{kip}$$

Demand to Capacity Ratio

$$\text{Check}_{bs} := \begin{cases} \frac{V_d}{R_{rbs}} & \text{if } R_{rbs} \geq V_d \\ \text{"Revise splice plate"} & \text{if } R_{rbs} < V_d \end{cases}$$

$$\text{Check}_{bs} = 0.39$$



Client IPC & MIMC Job Number 11215702 Sheet \_\_\_\_\_  
Project San Jacinto River Waste Pits Site Sheets By I.Goel Date 06/03/2022  
Subject Waler Section & Splice Connection Design Calculation Checked By S.Chilka Date 06/03/2022

### Bearing Resistance Check, Eq. J3-6a

Nominal bearing strength at bolt holes  $R_{nb} := 2.4 \cdot (db) \cdot twsp \cdot F_u \cdot N_f = 1.42 \times 10^3 \cdot \text{kip}$

Overstrength Factor  $\Omega_{bh} := 2$

Allowable bearing strength at bolt holes  $R_{rb} := \frac{R_{nb}}{\Omega_{bh}} = 707.7 \cdot \text{kip}$

Demand to Capacity Ratio

$$\text{Check}_{bh} := \begin{cases} \frac{V_r}{R_{rb}} & \text{if } R_{rb} \geq V_r \\ \text{"Revise splice plate or bolts"} & \text{if } R_{rb} < V_r \end{cases} = 0.15$$

### Tearout Resistance Check, Eq. J3-6c

l<sub>c</sub> for edge bolts  $l_{co} := S_{prov} - \left( \frac{dbh}{2} \right) = 1.25 \cdot \text{in}$

l<sub>c</sub> for inner bolts  $l_{ci} := S_{prov} - dbh = 2.5 \cdot \text{in}$

Inner bolts on each side of splice  $N_i := 0$

For edge bolts, nominal tearout strength at bolt holes  $R_{nto} := 1.2 \cdot twsp \cdot F_u \cdot l_{co} \cdot (N_f - N_i) = 643.37 \cdot \text{kip}$

For inner bolts, nominal tearout strength at bolt holes  $R_{nti} := 1.2 \cdot twsp \cdot F_u \cdot l_{ci} \cdot N_i = 0 \cdot \text{kip}$



Client IPC & MIMC Job Number 11215702 Sheet \_\_\_\_\_  
Project San Jacinto River Waste Pits Site Sheets By I.Goel Date 06/03/2022  
Subject Waler Section & Splice Connection Design Calculation Checked By S.Chilka Date 06/03/2022

Total nominal tearout strength at bolt holes  $R_{nt} := R_{nto} + R_{nti} = 643.37 \cdot \text{kip}$

Overstrength factor  $\Omega_{bt} := 2$

Allowable tearout strength at bolt holes  $R_{rt} := \frac{R_{nt}}{\Omega_{bt}} = 321.68 \cdot \text{kip}$

Demand to Capacity Ratio

$$\text{Checkth} := \begin{cases} \frac{V_r}{R_{rt}} & \text{if } R_{rt} \geq V_r \\ \text{"Revise splice plate or bolts"} & \text{if } R_{rt} < V_r \end{cases} = 0.34$$

#### Slip Resistance Check, Eq. J3-4

For class A surfaces  $\mu := 0.3$

$D_u := 1.13$

Minimum bolt pretension, Table J3.1 for Group A, A325 bolts  $T_b := 97 \text{kip}$

$h_f := 1$

Nominal slip resistance of bolts  $R_{sr} := N_f \cdot N_s \cdot \mu \cdot D_u \cdot T_b \cdot h_f = 197.3 \cdot \text{kip}$

Overstrength Factor  $\Omega_{sr} := 1.5$

Allowable slip resistance of bolts  $R_{rslr} := \frac{R_{sr}}{\Omega_{sr}} = 131.53 \cdot \text{kip}$



Client IPC & MIMC Job Number 11215702 Sheet \_\_\_\_\_  
Project San Jacinto River Waste Pits Site Sheets By I.Goel Date 06/03/2022  
Subject Waler Section & Splice Connection Design Calculation Checked By S.Chilka Date 06/03/2022

Demand to Capacity Ratio

$$\text{Checkslr} := \begin{cases} \frac{V_r}{R_{rslr}} & \text{if } R_{rslr} \geq V_r \\ \text{"Revise bolts size"} & \text{if } R_{rslr} < V_r \end{cases} = 0.82$$

### Design Summary

**Provide rectangular splice plate of 24"X8", 1.25" thickness. On each side of web splice bolted plate connection, provide 6 - 1.375" dia HDG Group A - A325 bolts.**



Client IPC & MIMC Job Number 11215702 Sheet \_\_\_\_\_  
 Project San Jacinto River Waste Pits Site Sheets By I.Goel Date 06/03/2022  
 Subject Waler Section & Splice Connection Design Calculation Checked By S.Chilka Date 06/03/2022

### Analysis Demand Load on Waler - Sec C5, C3

Tie Rod Tension Demand Load from Analysis

$$T_{roda} := 105.2 \text{kip}$$

Reduced to 90 kips  
 July 2024  
 This calculation is still okay.

Tie Rod Spacing

$$S_{roda} := 6 \text{ft}$$

The tie rod spacing assumed in analysis results in large demand loads and section size for waler. To optimize section selection, tie rods will be closely spaced. Closely spaced tie rods will result in lower demand loads.

Revised Tie Rod Spacing

$$S_{rod} := 5 \text{ft}$$

Revised Tie Rod Tension Demand

$$T_{rod} := T_{roda} \cdot \frac{S_{rod}}{S_{roda}} = 87.67 \cdot \text{kip}$$

Demand Load on waler

$$w_{dl} := \frac{T_{rod}}{S_{rod}} = 17.53 \cdot \frac{\text{kip}}{\text{ft}}$$

### Demand Load on Waler to safeguard against progressive failure

In certain situations, progressive collapse of the structure may be a consequence of an extreme condition ie. failure of a tie rod. The walling to the main wall will need to be checked to ensure that it will not collapse if the span between tie rods doubles following the loss of a tie rod.

SAP2000 analysis is used to calculate the bending moment and shear force demand on the waler for both the cases. Case 1 - without failure of a tie rod and, Case 2 - with failure of a tie rod.

For Case 1 - Continuous beam with four equal spans of length  $S_{rod}$  is analyzed  
 For Case 2 - Continuous beam with three spans of length  $S_{rod} - 2S_{rod} - S_{rod}$  is analyzed

Waler Design is governed by the demands from Case 2



Client IPC & MIMC Job Number 11215702 Sheet \_\_\_\_\_  
Project San Jacinto River Waste Pits Site Sheets By I.Goel Date 06/03/2022  
Subject Waler Section & Splice Connection Design Calculation Checked By S.Chilka Date 06/03/2022

### Bending Moment Diagram - Case 1

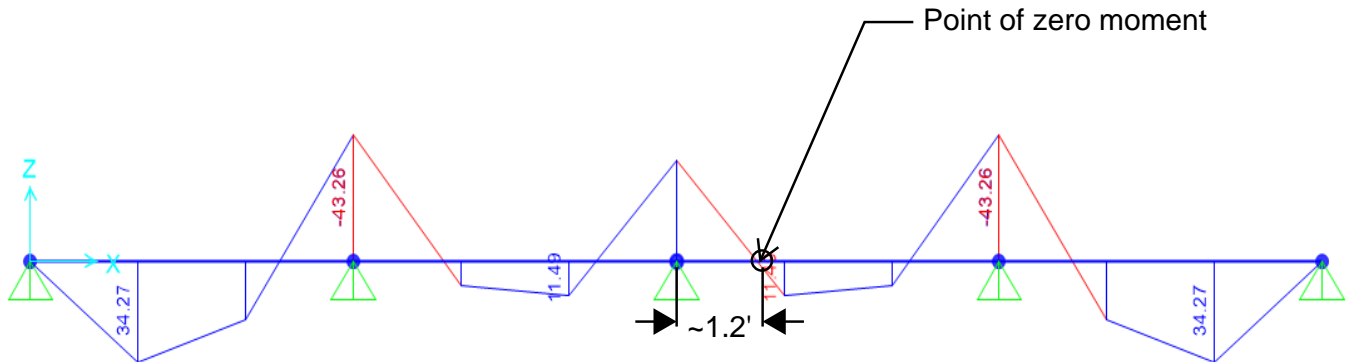

Bending Moment demand from SAP2000 -  $M_{dsap} = 43.26 \text{ Kip-ft}$

### Shear Force Diagram - Case 1

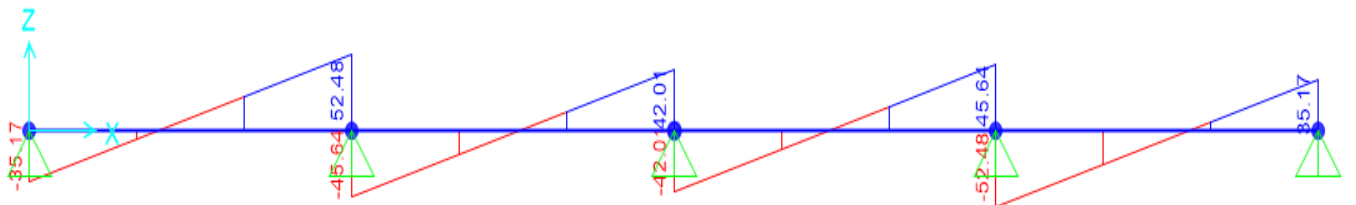

Shear Force demand from SAP2000 -  $V_{dsap} = 52.5 \text{ Kip}$





Client IPC & MIMC Job Number 11215702 Sheet \_\_\_\_\_  
Project San Jacinto River Waste Pits Site Sheets By I.Goel Date 06/03/2022  
Subject Waler Section & Splice Connection Design Calculation Checked By S.Chilka Date 06/03/2022

## Waler Cross-Section

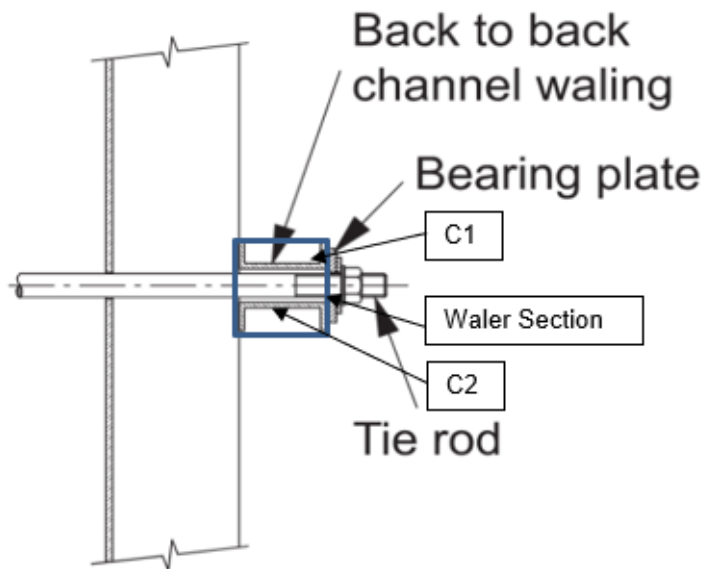

Waler is made of two channel sections C1 and C2

## Design of corroded waler section, AISC 360-16

Bending moment demand on waler from SAP2000

$$M_{dsap} := 119.85 \text{ kip}\cdot\text{ft}$$

Shear force demand on waler from SAP2000

$$V_{dsap} := 87.7 \text{ kip}$$

Bending moment demand on C1 or C2

$$M_d := \frac{M_{dsap}}{2} = 59.92 \text{ kip}\cdot\text{ft}$$

Shear force demand on C1 or C2

$$V_d := \frac{V_{dsap}}{2} = 43.85 \text{ kip}$$



Client IPC & MIMC Job Number 11215702 Sheet \_\_\_\_\_  
Project San Jacinto River Waste Pits Site Sheets By I.Goel Date 06/03/2022  
Subject Waler Section & Splice Connection Design Calculation Checked By S.Chilka Date 06/03/2022

Steel yield stress  $F_y := 36\text{ksi}$

Steel tensile stress  $F_u := 58\text{ksi}$

Modulus of Elasticity of steel  $E := 29000\text{ksi}$

Sacrificial thickness - for accounting corrosion  $t_c := 0.0175\text{in}$

Refer Basis of Design  
report

### Channel Section Dimensional Parameters (MC12X35)

Depth  $d := 12\text{in}$

Web thickness  $t_w := 0.4375\text{in}$

Flange thickness  $t_f := 0.6875\text{in}$

Flange width  $b_f := 3.75\text{in}$

Distance  $k := 1.3125\text{in}$

### Corroded Channel Section Dimensional Parameters (MC12X35)

Web thickness  $t_{wc} := t_w - 2t_c = 0.4\text{in}$

Flange thickness  $t_{fc} := t_f - 2t_c = 0.65\text{in}$



Client IPC & MIMC Job Number 11215702 Sheet \_\_\_\_\_  
Project San Jacinto River Waste Pits Site Sheets By I.Goel Date 06/03/2022  
Subject Waler Section & Splice Connection Design Calculation Checked By S.Chilka Date 06/03/2022

## Sectional Properties of Corroded Section

Plastic modulus about x axis

$$Z_x := \left[ (bf) \cdot \frac{(d)^2}{4} \right] - \left[ [(bf) - (twc)] \cdot \frac{[(d) - [2 \cdot (tfc)]]^2}{4} \right] = 39.28 \cdot \text{in}^3$$

Elastic modulus about x axis

$$S_x := \frac{\left[ (bf) \cdot \frac{(d)^3}{12} \right] - \left[ [(bf) - (twc)] \cdot \frac{[(d) - [2 \cdot (tfc)]]^3}{12} \right]}{(d) \cdot 0.5} = 33.12 \cdot \text{in}^3$$

Torsion constant

$$J_w := \frac{\left[ 2 \cdot (bf) \cdot (tfc)^3 \right] + \left[ [(d) - (tfc)] \cdot (twc)^3 \right]}{3} = 0.94 \cdot \text{in}^4$$

Moment of Inertia about external edge  
of web parallel to y axis

$$I_{y0} := \left[ [(d) - [2 \cdot (tfc)]] \cdot \frac{(twc)^3}{3} \right] + \left[ (bf)^3 \cdot (tfc) \cdot \frac{2}{3} \right] = 23.17 \cdot \text{in}^4$$

Cross sectional area

$$A_c := [2 \cdot (bf) \cdot (tfc)] + [(d) - [2 \cdot (tfc)]] \cdot (twc) = 9.2 \cdot \text{in}^2$$



Client IPC & MIMC Job Number 11215702 Sheet \_\_\_\_\_  
Project San Jacinto River Waste Pits Site Sheets By I.Goel Date 06/03/2022  
Subject Waler Section & Splice Connection Design Calculation Checked By S.Chilka Date 06/03/2022

Distance of centroid from external edge  
of web

$$x_c := \frac{\left[ [(d) - [2 \cdot (tfc)]] \cdot \frac{(twc)^2}{2} \right] + [(bf)^2 \cdot (tfc)]}{A_c} = 1.09 \cdot \text{in}$$

Moment of inertia about y axis

$$I_y := I_{y0} - (A_c \cdot x_c^2) = 12.21 \cdot \text{in}^4$$

Distance between flange centroids

$$h_o := (d) - (tfc) = 11.35 \cdot \text{in}$$

Warping torsional constant

$$C_w := \frac{[(tfc) \cdot (bf)^3 \cdot [(d) - (tfc)]^2] \cdot [[3 \cdot (bf) \cdot (tfc)] + [2 \cdot (twc) \cdot [(d) - (tfc)]]]}{12 \cdot [[6 \cdot (bf) \cdot (tfc)] + [(twc) \cdot [(d) - (tfc)]]]}$$

$$C_w = 316.03 \cdot \text{in}^6$$

radius of gyration about y axis

$$r_y := \sqrt{\frac{I_y}{A_c}} = 1.15 \cdot \text{in}$$

Overstrength factor for flexure

$$\Omega_f := 1.67$$

Overstrength factor for shear

$$\Omega_v := 1.67$$

## Classification of sections for local buckling - Section B4.1

### Classification of flanges in flexure - Table B4.1b (case 10)

Width - to - Thickness Ratio for flange

$$a_f := \frac{bf}{tfc} = 5.75$$



Client IPC & MIMC Job Number 11215702 Sheet \_\_\_\_\_  
 Project San Jacinto River Waste Pits Site Sheets By I.Goel Date 06/03/2022  
 Subject Waler Section & Splice Connection Design Calculation Checked By S.Chilka Date 06/03/2022

Limiting width to thickness ratio for compact flange section about major/minor axis

$$\lambda_{cf} := 0.38 \cdot \sqrt{\frac{E}{F_y}} = 10.79$$

Limiting width to thickness ratio for non compact flange section about major/minor axis

$$\lambda_{nf} := 1 \sqrt{\frac{E}{F_y}} = 28.38$$

#### Classification of web in flexure - Table B4.1b (case 15)

Width - to - Thickness Ratio for web

$$a_w := \frac{(d) - [2 \cdot (k - 2t_c)]}{t_{wc}} = 23.47$$

Limiting width to thickness ratio for compact web section about major/minor axis

$$\lambda_{cw} := 3.76 \cdot \sqrt{\frac{E}{F_y}} = 106.72$$

Limiting width to thickness ratio for non compact web section about major/minor axis

$$\lambda_{nw} := 5.7 \sqrt{\frac{E}{F_y}} = 161.78$$

$$c_{n_{ff}} := \begin{cases} \text{"Compact flange"} & \text{if } a_f \leq \lambda_{cf} \\ \text{"Non compact flange"} & \text{if } \lambda_{cf} \leq a_f \leq \lambda_{nf} \\ \text{"Slender flange"} & \text{otherwise} \end{cases} = \text{"Compact flange"}$$

$$c_{n_{wf}} := \begin{cases} \text{"Compact web"} & \text{if } a_w \leq \lambda_{cw} \\ \text{"Non compact web"} & \text{if } \lambda_{cw} \leq a_w \leq \lambda_{nw} \\ \text{"Slender flange web"} & \text{otherwise} \end{cases} = \text{"Compact web"}$$

#### Allowable Stress Shear Design - Chapter G

Web area

$$A_w := (d) \cdot (t_{wc}) = 4.83 \cdot \text{in}^2$$

Web plate buckling coefficient

$$K_v := 5.34$$



Client IPC & MIMC Job Number 11215702 Sheet \_\_\_\_\_  
Project San Jacinto River Waste Pits Site Sheets By I.Goel Date 06/03/2022  
Subject Waler Section & Splice Connection Design Calculation Checked By S.Chilka Date 06/03/2022

$$r := 1.1 \cdot \left( K_v \cdot \frac{E}{F_y} \right)^{\frac{1}{2}} = 72.15$$

$$r1 := \frac{(d) - [2 \cdot (tfc)]}{twc} = 26.57$$

Web shear coefficient, Eq G2-3  
and Eq G2-4

$$C_{v1} := \begin{cases} 1 & \text{if } r \geq r1 \\ \frac{r}{r1} & \text{if } r < r1 \end{cases}$$

$$C_{v1} = 1$$

Nominal shear strength, Eq G2-1

$$V_n := 0.6 \cdot C_{v1} \cdot A_w \cdot F_y = 104.33 \cdot \text{kip}$$

Allowable shear strength

$$v_c := \frac{V_n}{\Omega_v} = 62.47 \cdot \text{kip}$$

Check for shear strength

$$\text{Check}_{vc} := \begin{cases} \frac{V_d}{v_c} & \text{if } v_c \geq V_d \\ \text{"Revise waler section"} & \text{if } v_c < V_d \end{cases}$$

$$\text{Check}_{vc} = 0.7$$

## Allowable Stress Flexure design about major axis - Chapter F

### Yielding - Section F2.1

Nominal flexural strength for yielding, Eq F2-1

$$M_{nyld} := F_y \cdot Z_x = 117.83 \cdot \text{kip} \cdot \text{ft}$$



Client IPC & MIMC Job Number 11215702 Sheet \_\_\_\_\_  
Project San Jacinto River Waste Pits Site Sheets By I.Goel Date 06/03/2022  
Subject Waler Section & Splice Connection Design Calculation Checked By S.Chilka Date 06/03/2022

### Lateral Torsional Buckling - Section F2.2

Unbraced length  $L_b := S_{rod} \cdot 2 = 120 \cdot \text{in}$

Limiting unbraced length for yielding Eq F2-5  $L_p := 1.76 \cdot r_y \cdot \sqrt{\frac{E}{F_y}} = 57.55 \cdot \text{in}$

Eq F2-8b  $cf := \left(\frac{h_o}{2}\right) \cdot \sqrt{\frac{I_y}{C_w}} = 1.12$

Eq F2-7  $r_{ts} := \sqrt{\frac{I_y \cdot C_w}{S_x}} = 1.37 \cdot \text{in}$

Eq F2-6 
$$L_r := 1.95 \cdot r_{ts} \cdot \frac{E \cdot \sqrt{\left(\frac{J \cdot cf}{S_x \cdot h_o}\right)^2 + \left(\frac{J \cdot cf}{S_x \cdot h_o}\right)^2 + 6.76 \cdot \left(0.7 \cdot \frac{F_y}{E}\right)^2}}{(0.7 \cdot F_y)} = 245.54 \cdot \text{in}$$

From SAP2000 analysis, for calculation of  $C_b$  ( $L_p < L_b \leq L_r$ )

Moment at quarter point of unbraced segment  $M_a := 37.9 \text{kip} \cdot \text{ft}$

Moment at center line of unbraced segment  $M_b := 90.5 \text{kip} \cdot \text{ft}$

Moment at three quarter point of unbraced segment  $M_c := 37.9 \text{kip} \cdot \text{ft}$

Maximum moment in unbraced segment  $M_{abs} := 119.85 \text{kip} \cdot \text{ft}$



Client IPC & MIMC Job Number 11215702 Sheet \_\_\_\_\_  
Project San Jacinto River Waste Pits Site Sheets By I.Goel Date 06/03/2022  
Subject Waler Section & Splice Connection Design Calculation Checked By S.Chilka Date 06/03/2022

Plastic moment capacity  $M_p := M_{nyld}$

Lateral torsional buckling modification factor, Eq F1-1

$$C_b := 12.5 \cdot \frac{M_{abs}}{[(2.5 \cdot M_{abs}) + (3 \cdot M_a) + (4 \cdot M_b) + (3 \cdot M_c)]} = 1.69$$

Nominal flexural strength for lateral torsional buckling - Eq F2-2  $M_{nlb} := C_b \cdot \left[ M_p - (M_p - 0.7 \cdot F_y \cdot S_x) \cdot \frac{(L_b - L_p)}{(L_r - L_p)} \right]$

$$M_{nlb} = 171.53 \cdot \text{kip} \cdot \text{ft}$$

Nominal flexural strength  $M_n := \min(M_{nyld}, M_{nlb}) = 117.83 \cdot \text{kip} \cdot \text{ft}$

Design flexure strength  $m_c := \frac{M_n}{\Omega_f} = 70.56 \cdot \text{kip} \cdot \text{ft}$

Check for flexural strength  $\text{Check}_{m_c} := \begin{cases} \frac{M_d}{m_c} & \text{if } m_c \geq M_d \\ \text{"Revise waler section"} & \text{if } m_c < M_d \end{cases}$

$$\text{Check}_{m_c} = 0.85$$

## Deflection Check

Limiting Deflection  $L_{ld} := \frac{L_b}{360} = 0.33 \cdot \text{in}$

Maximum deflection from SAP2000 analysis  $L_{md} := 0.21 \text{ in}$



Client IPC & MIMC Job Number 11215702 Sheet \_\_\_\_\_  
 Project San Jacinto River Waste Pits Site Sheets By I.Goel Date 06/03/2022  
 Subject Waler Section & Splice Connection Design Calculation Checked By S.Chilka Date 06/03/2022

Demand to Capacity Ratio

$$\text{Check}_d := \begin{cases} \frac{L_{md}}{L_{ld}} & \text{if } L_{ld} \geq L_{md} \\ \text{"Revise unbraced length"} & \text{if } L_{ld} < L_{md} \end{cases}$$

$$\text{Check}_d = 0.63$$

### Bolted Splice Plate Connection Design for Waler, Allowable Stress Design - AISC 360-16

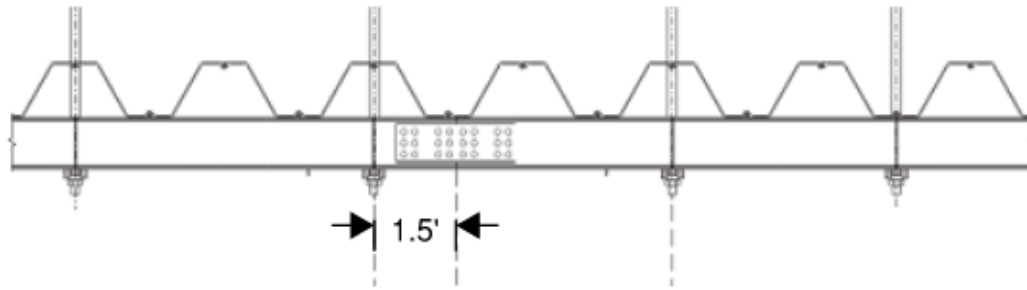

From SAP2000 analysis, point of zero moment in typical span for case 1 is ~1.2' and for case 2 is ~1.7' from tie rod anchorage. Point of splice connection for design is 1.5' from tie rod anchorage.

### Resultant Web Force at Point of Splice Connection

Bending moment demand at point of splice, from SAP2000 analysis

$$M_{sd} := 14.7 \text{ kip}\cdot\text{ft}$$

Horizontal force in web due to moment at point of splice

$$H_w := \frac{M_{sd} \cdot 4}{[d - [2 \cdot (k - 2tc)]]} = 74.71 \cdot \text{kip}$$

Resultant web force at point of splice connection

$$V_r := \sqrt{V_d^2 + H_w^2} = 86.62 \cdot \text{kip}$$



Client IPC & MIMC Job Number 11215702 Sheet \_\_\_\_\_  
 Project San Jacinto River Waste Pits Site Sheets By I.Goel Date 06/03/2022  
 Subject Waler Section & Splice Connection Design Calculation Checked By S.Chilka Date 06/03/2022

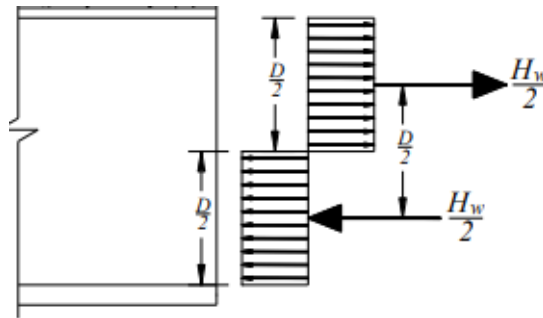

$$\text{Web Moment} = \frac{H_w \left( \frac{D}{2} \right)}{2}$$

$$H_w = \frac{\text{Web Moment}}{D/4}$$

**Factored shear resistance of bolts in shear**

No of shear planes

$N_s := 1$

**Section J3, Table J3.2**

Using HDG Group A, A325 bolts

Nominal shear stress when threads are not excluded from shear planes

$F_{nv} := 54\text{ksi}$

**Taking 1.25" nominal diameter bolt**

Bolt nominal diameter

$db := 1.25\text{in}$

Nominal unthreaded body area of bolt

$A_b := 3.14 \cdot (db)^2 \cdot 0.25 = 1.23 \cdot \text{in}^2$

Nominal shear strength of bolt

$R_n := F_{nv} \cdot A_b \cdot N_s = 66.23 \cdot \text{kip}$

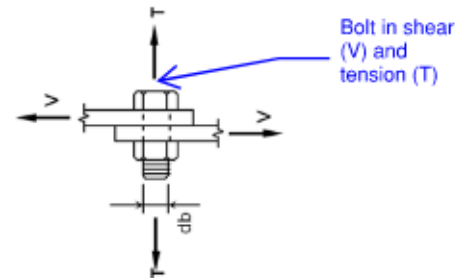



Client IPC & MIMC Job Number 11215702 Sheet \_\_\_\_\_  
Project San Jacinto River Waste Pits Site Sheets By I.Goel Date 06/03/2022  
Subject Waler Section & Splice Connection Design Calculation Checked By S.Chilka Date 06/03/2022

Overstrength factor

$$\Omega_b := 2$$

Allowable shear strength of bolt

$$R_r := \frac{R_n}{\Omega_b} = 33.12 \cdot \text{kip}$$

No of bolts required on each side of the web splice

$$N_b := \frac{V_r}{R_r} = 2.62$$

No of bolts provided on each side of the web splice

$$N_f := 6$$

No of bolt columns in connection pattern along the length of splice plate

$$N_r := 3$$

### Bolt Connection Pattern

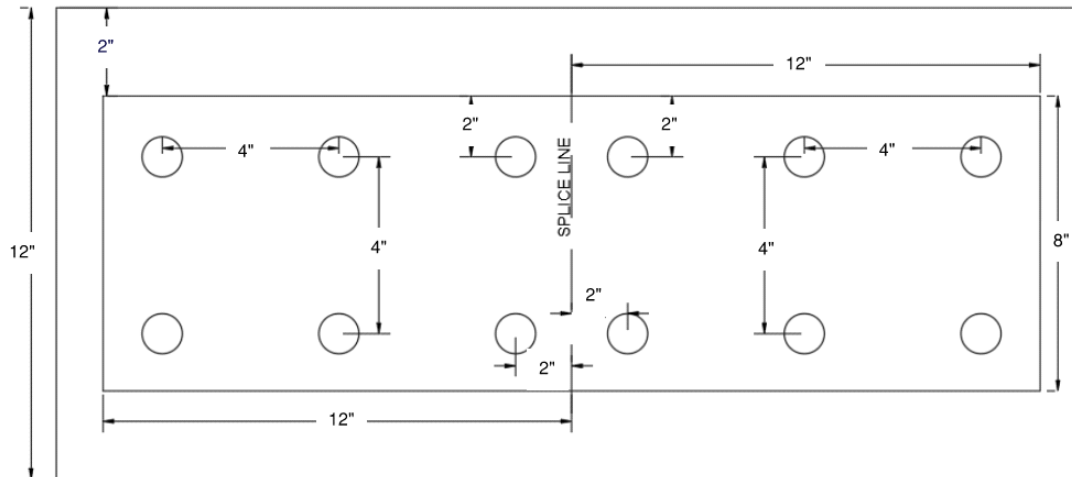

Table J3.3, for 1.25" bolt dia, standard hole dia is 1.375"

Hole diameter

$$d_{bh} := 1.375 \text{ in}$$



Client IPC & MIMC Job Number 11215702 Sheet \_\_\_\_\_  
Project San Jacinto River Waste Pits Site Sheets By I.Goel Date 06/03/2022  
Subject Waler Section & Splice Connection Design Calculation Checked By S.Chilka Date 06/03/2022

Minimum center to center spacing allowed b/w holes, Sec J3.3  $S_{min} := \frac{8 \cdot (db)}{3} = 3.33 \cdot \text{in}$

Minimum clear spacing allowed b/w holes, Sec J3.3  $S_{cmin} := db = 1.25 \cdot \text{in}$

Table J3.4, minimum edge distance allowed for 1.25" bolt dia  $S_{emin} := 1.625 \text{in}$

**Providing a splice plate of 24"X8", 0.75" thickness for the connection**

No of splice plates in the connection  $N_{sp} := 1$

**Eq. J4-3 and J4-4, strength of elements in shear**

Depth of splice plate  $d_{sp} := 8 \text{in}$

Thickness of splice plate  $T_{wsp} := 0.75 \text{in}$

Reduced thickness of splice plate - for accounting corrosion  $tw_{sp} := T_{wsp} - t_c = 0.73 \cdot \text{in}$

Gross area subject to shear  $A_{gv} := d_{sp} \cdot tw_{sp} = 5.86 \cdot \text{in}^2$

Nominal shear yielding strength  $R_{nsy} := 0.6 \cdot F_y \cdot A_{gv} \cdot N_{sp} = 126.58 \cdot \text{kip}$



Client IPC & MIMC Job Number 11215702 Sheet \_\_\_\_\_  
Project San Jacinto River Waste Pits Site Sheets By I.Goel Date 06/03/2022  
Subject Waler Section & Splice Connection Design Calculation Checked By S.Chilka Date 06/03/2022

Overstrength factor  $\Omega_{spsy} := 1.5$

Allowable shear yielding strength  $R_{rsy} := \frac{R_{nsy}}{\Omega_{spsy}} = 84.38 \cdot \text{kip}$

Demand to Capacity Ratio  $\text{Checksy} := \begin{cases} \frac{V_d}{R_{rsy}} & \text{if } R_{rsy} \geq V_d \\ \text{"Revise splice plate"} & \text{if } R_{rsy} < V_d \end{cases}$

$\text{Checksy} = 0.52$

Net area subject to shear  $A_{nv} := \left[ d_{sp} - \left( N_f \cdot \frac{d_{bh}}{N_r} \right) \right] \cdot t_{wsp} = 3.85 \cdot \text{in}^2$

Nominal shear rupture strength  $R_{nsr} := 0.6 \cdot F_u \cdot A_{nv} \cdot N_{sp} = 133.83 \cdot \text{kip}$

Overstrength factor  $\Omega_{spsr} := 2$

Allowable shear rupture strength  $R_{rsr} := \frac{R_{nsr}}{\Omega_{spsr}} = 66.91 \cdot \text{kip}$

Demand to Capacity ratio  $\text{Checksr} := \begin{cases} \frac{V_d}{R_{rsr}} & \text{if } R_{rsr} \geq V_d \\ \text{"Revise splice plate"} & \text{if } R_{rsr} < V_d \end{cases}$

$\text{Checksr} = 0.66$



Client IPC & MIMC Job Number 11215702 Sheet \_\_\_\_\_  
Project San Jacinto River Waste Pits Site Sheets By I.Goel Date 06/03/2022  
Subject Waler Section & Splice Connection Design Calculation Checked By S.Chilka Date 06/03/2022

### Maximum spacing and edge distance - Section J3-5

Maximum edge distance

$$S_{max} := \begin{cases} 12 \cdot \min(t_w, T_{wsp}) & \text{if } 12 \cdot \min(t_w, T_{wsp}) \leq 6 \text{ in} \\ 6 \text{ in} & \text{if } 12 \cdot \min(t_w, T_{wsp}) > 6 \text{ in} \end{cases} = 5.25 \cdot \text{in}$$

Maximum center to center longitudinal spacing  
allowed b/w holes

$$S_{max} := \begin{cases} 24 \cdot \min(t_w, T_{wsp}) & \text{if } 24 \cdot \min(t_w, T_{wsp}) \leq 12 \text{ in} \\ 12 \text{ in} & \text{if } 24 \cdot \min(t_w, T_{wsp}) > 12 \text{ in} \end{cases} = 10.5 \cdot \text{in}$$

Distance of bolt from splice plate edge

$$S_{prov} := 2 \text{ in}$$

Distance of bolt from channel section flange  
inner edge

$$S_{prov} := S_{prov} + [(d - dsp) \cdot 0.5 - k] = 2.69 \cdot \text{in}$$

Spacing provided between bolts

$$S_{prov} := 4 \text{ in}$$

Check for bolt edge distance provided

$$S_{check} := \begin{cases} \text{"Okay"} & \text{if } S_{min} \leq \max(S_{prov}, S_{prov}) \leq S_{max} \\ \text{"Not Okay"} & \text{otherwise} \end{cases} = \text{"Okay"}$$

Check for spacing provided between bolts

$$S_{check} := \begin{cases} \text{"Okay"} & \text{if } (\max(S_{min}, S_{min} + dbh) \leq S_{prov} \leq S_{max}) \\ \text{"Not Okay"} & \text{otherwise} \end{cases} = \text{"Okay"}$$



Client IPC & MIMC Job Number 11215702 Sheet \_\_\_\_\_  
 Project San Jacinto River Waste Pits Site Sheets By I.Goel Date 06/03/2022  
 Subject Waler Section & Splice Connection Design Calculation Checked By S.Chilka Date 06/03/2022

**Block Shear Rupture Check, Eq. J4-5**

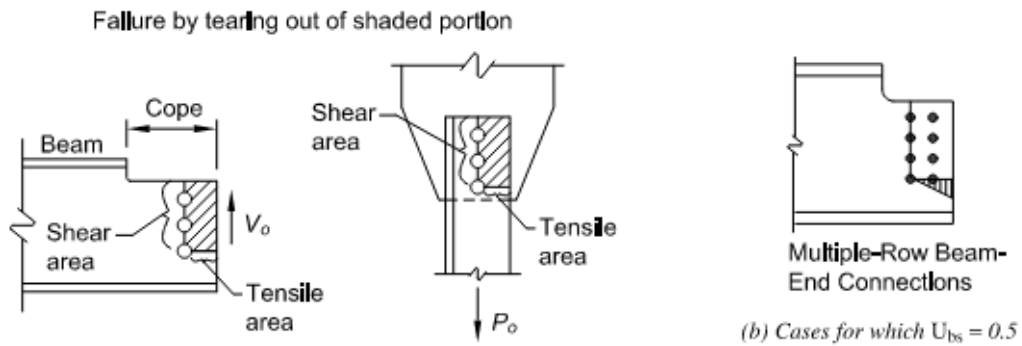

Fig. C-J4.1. Failure surface for block shear rupture limit state.

No of bolts in the outermost edge of the connection pattern which is in tension

$N_{br} := 3$

Net Area resisting the tensile stress

$$A_{nt} := N_{sp} \cdot [S_{p_{rov}} + (N_{br} - 1)S_{p_{rov}} - [d_{bh} \cdot (N_{br} - 0.5)]] \cdot t_{wsp} = 4.81 \cdot \text{in}^2$$

Net Area resisting the shear stress

$$A_{vn} := N_{sp} \cdot \left[ d_{sp} - S_{p_{rov}} - \left[ \left( \frac{N_f}{N_r} \right) - 0.5 \right] \cdot d_{bh} \right] \cdot t_{wsp} = 2.88 \cdot \text{in}^2$$

Gross area resisting the shear stress

$$A_{vg} := N_{sp} \cdot (d_{sp} - S_{p_{rov}}) \cdot t_{wsp} = 4.39 \cdot \text{in}^2$$

Nominal block shear strength

$U_{bs} := 0.5$

$$R_{bs} := [(0.6 \cdot F_u \cdot A_{vn}) + (U_{bs} \cdot F_u \cdot A_{nt})] = 239.77 \cdot \text{kip}$$



Client IPC & MIMC Job Number 11215702 Sheet \_\_\_\_\_  
Project San Jacinto River Waste Pits Site Sheets By I.Goel Date 06/03/2022  
Subject Waler Section & Splice Connection Design Calculation Checked By S.Chilka Date 06/03/2022

$$R_{nbs} := \begin{cases} R_{bs} & \text{if } R_{bs} \leq [(0.6 \cdot F_y \cdot A_{vg}) + (U_{bs} \cdot F_u \cdot A_{nt})] \\ [(0.6 \cdot F_y \cdot A_{vg}) + (U_{bs} \cdot F_u \cdot A_{nt})] & \text{if } R_{bs} > [(0.6 \cdot F_y \cdot A_{vg}) + (U_{bs} \cdot F_u \cdot A_{nt})] \end{cases} = 234.34 \cdot \text{kip}$$

Overstrength Factor  $\Omega_{bs} := 2$

Allowable block shear strength  $R_{rbs} := \frac{R_{nbs}}{\Omega_{bs}} = 117.17 \cdot \text{kip}$

Demand to Capacity Ratio  $\text{Check}_{bs} := \begin{cases} \frac{V_d}{R_{rbs}} & \text{if } R_{rbs} \geq V_d \\ \text{"Revise splice plate"} & \text{if } R_{rbs} < V_d \end{cases}$

$\text{Check}_{bs} = 0.37$

#### **Bearing Resistance Check, Eq. J3-6a**

Nominal bearing strength at bolt holes  $R_{nb} := 2.4 \cdot (d_b) \cdot t_{wsp} \cdot F_u \cdot N_f = 764.73 \cdot \text{kip}$

Overstrength Factor  $\Omega_{bh} := 2$

Allowable bearing strength at bolt holes  $R_{rb} := \frac{R_{nb}}{\Omega_{bh}} = 382.36 \cdot \text{kip}$

Demand to Capacity Ratio

$$\text{Check}_{bh} := \begin{cases} \frac{V_r}{R_{rb}} & \text{if } R_{rb} \geq V_r \\ \text{"Revise splice plate or bolts"} & \text{if } R_{rb} < V_r \end{cases} = 0.23$$



Client IPC & MIMC Job Number 11215702 Sheet \_\_\_\_\_  
Project San Jacinto River Waste Pits Site Sheets By I.Goel Date 06/03/2022  
Subject Waler Section & Splice Connection Design Calculation Checked By S.Chilka Date 06/03/2022

### Tearout Resistance Check, Eq. J3-6c

l<sub>c</sub> for edge bolts  $l_{co} := S_{prov} - \left( \frac{dbh}{2} \right) = 1.31 \cdot \text{in}$

l<sub>c</sub> for inner bolts  $l_{ci} := S_{prov} - dbh = 2.63 \cdot \text{in}$

Inner bolts on each side of splice  $N_i := 0$

For edge bolts, nominal tearout strength at bolt holes  $R_{nto} := 1.2 \cdot t_{wsp} \cdot F_u \cdot l_{co} \cdot (N_f - N_i) = 401.48 \cdot \text{kip}$

For inner bolts, nominal tearout strength at bolt holes  $R_{nti} := 1.2 \cdot t_{wsp} \cdot F_u \cdot l_{ci} \cdot N_i = 0 \cdot \text{kip}$

Total nominal tearout strength at bolt holes  $R_{nt} := R_{nto} + R_{nti} = 401.48 \cdot \text{kip}$

Overstrength factor  $\Omega_{bt} := 2$

Allowable tearout strength at bolt holes  $R_{rt} := \frac{R_{nt}}{\Omega_{bt}} = 200.74 \cdot \text{kip}$

Demand to Capacity Ratio

$$\text{Checkth} := \begin{cases} \frac{V_r}{R_{rt}} & \text{if } R_{rt} \geq V_r \\ \text{"Revise splice plate or bolts"} & \text{if } R_{rt} < V_r \end{cases} = 0.43$$



Client IPC & MIMC Job Number 11215702 Sheet \_\_\_\_\_  
Project San Jacinto River Waste Pits Site Sheets By I.Goel Date 06/03/2022  
Subject Waler Section & Splice Connection Design Calculation Checked By S.Chilka Date 06/03/2022

### Slip Resistance Check, Eq. J3-4

For class A surfaces

$$\mu := 0.3$$

$$D_u := 1.13$$

Minimum bolt pretension, Table J3.1 for Group A, A325 bolts

$$T_b := 81 \text{ kip}$$

$$h_f := 1$$

Nominal slip resistance of bolts

$$R_{sr} := N_f \cdot N_s \cdot \mu \cdot D_u \cdot T_b \cdot h_f = 164.75 \cdot \text{kip}$$

Overstrength Factor

$$\Omega_{sr} := 1.5$$

Allowable slip resistance of bolts

$$R_{rslr} := \frac{R_{sr}}{\Omega_{sr}} = 109.84 \cdot \text{kip}$$

Demand to Capacity Ratio

$$\text{Checks}_{lr} := \begin{cases} \frac{V_r}{R_{rslr}} & \text{if } R_{rslr} \geq V_r \\ \text{"Revise bolts size"} & \text{if } R_{rslr} < V_r \end{cases} = 0.79$$

### Design Summary

**Provide rectangular splice plate of 24"X8",0.75" thickness. On each side of web splice bolted plate connection, provide 6 - 1.25" dia HDG Group A - A325 bolts.**



Client IPC & MIMC Job Number 11215702 Sheet \_\_\_\_\_  
Project San Jacinto River Waste Pits Site Sheets By I.Goel Date 06/03/2022  
Subject Waler Section & Splice Connection Design Calculation Checked By S.Chilka Date 06/03/2022

## Analysis Demand Load on Waler - Sec C4

Tie Rod Tension Demand Load from Analysis  $T_{roda} := 122.98 \text{kip}$

Tie Rod Spacing  $S_{roda} := 8 \text{ft}$

The tie rod spacing assumed in analysis results in large demand loads and section size for waler. To optimize section selection, tie rods will be closely spaced. Closely spaced tie rods will result in lower demand loads.

Revised Tie Rod Spacing  $S_{rod} := 5 \text{ft}$

Revised Tie Rod Tension Demand  $T_{rod} := T_{roda} \cdot \frac{S_{rod}}{S_{roda}} = 76.86 \cdot \text{kip}$

Demand Load on waler  $w_{dl} := \frac{T_{rod}}{S_{rod}} = 15.37 \cdot \frac{\text{kip}}{\text{ft}}$

## Demand Load on Waler to safeguard against progressive failure

In certain situations, progressive collapse of the structure may be a consequence of an extreme condition ie. failure of a tie rod. The wailing to the main wall will need to be checked to ensure that it will not collapse if the span between tie rods doubles following the loss of a tie rod.

SAP2000 analysis is used to calculate the bending moment and shear force demand on the waler for both the cases. Case 1 - without failure of a tie rod and, Case 2 - with failure of a tie rod.

For Case 1 - Continuous beam with four equal spans of length  $S_{rod}$  is analyzed  
For Case 2 - Continuous beam with three spans of length  $S_{rod} - 2S_{rod} - S_{rod}$  is analyzed

Waler Design is governed by the demands from Case 2







Client IPC & MIMC Job Number 11215702 Sheet \_\_\_\_\_  
Project San Jacinto River Waste Pits Site Sheets By I.Goel Date 06/03/2022  
Subject Waler Section & Splice Connection Design Calculation Checked By S.Chilka Date 06/03/2022

## Waler Cross-Section

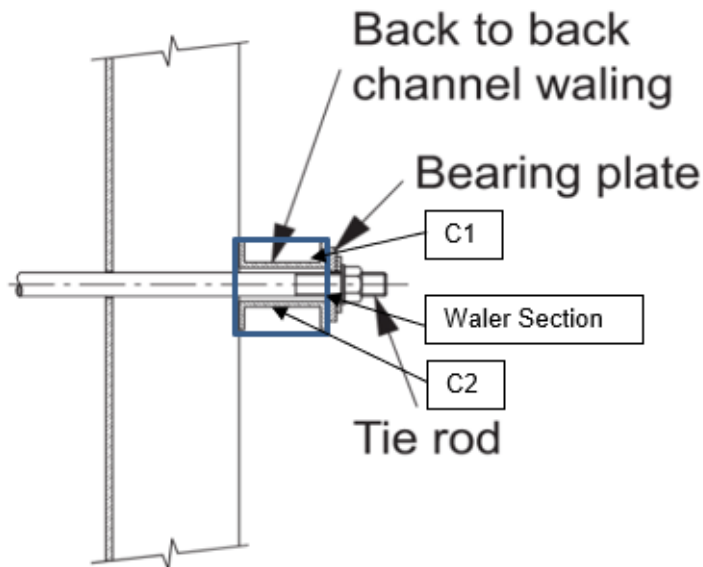

Waler is made of two channel sections C1 and C2

## Design of corroded waler section, AISC 360-16

Bending moment demand on waler from SAP2000

$$M_{dsap} := 105.1 \text{ kip}\cdot\text{ft}$$

Shear force demand on waler from SAP2000

$$V_{dsap} := 76.9 \text{ kip}$$

Bending moment demand on C1 or C2

$$M_d := \frac{M_{dsap}}{2} = 52.55 \text{ kip}\cdot\text{ft}$$

Shear force demand on C1 or C2

$$V_d := \frac{V_{dsap}}{2} = 38.45 \text{ kip}$$



Client IPC & MIMC Job Number 11215702 Sheet \_\_\_\_\_  
Project San Jacinto River Waste Pits Site Sheets By I.Goel Date 06/03/2022  
Subject Waler Section & Splice Connection Design Calculation Checked By S.Chilka Date 06/03/2022

Steel yield stress  $F_y := 36\text{ksi}$

Steel tensile stress  $F_u := 58\text{ksi}$

Modulus of Elasticity of steel  $E := 29000\text{ksi}$

Sacrificial thickness - for accounting corrosion  $t_c := 0.0175\text{in}$  Refer Basis of Design report

#### Channel Section Dimensional Parameters (MC12X35)

Depth  $d := 12\text{in}$

Web thickness  $t_w := 0.4375\text{in}$

Flange thickness  $t_f := 0.6875\text{in}$

Flange width  $b_f := 3.75\text{in}$

Distance  $k := 1.3125\text{in}$

#### Corroded Channel Section Dimensional Parameters (MC12X35)

Web thickness  $t_{wc} := t_w - 2t_c = 0.4\text{in}$

Flange thickness  $t_{fc} := t_f - 2t_c = 0.65\text{in}$



Client IPC & MIMC Job Number 11215702 Sheet \_\_\_\_\_  
Project San Jacinto River Waste Pits Site Sheets By I.Goel Date 06/03/2022  
Subject Waler Section & Splice Connection Design Calculation Checked By S.Chilka Date 06/03/2022

## Sectional Properties of Corroded Section

Plastic modulus about x axis

$$Z_x := \left[ (bf) \cdot \frac{(d)^2}{4} \right] - \left[ [(bf) - (twc)] \cdot \frac{[(d) - [2 \cdot (tfc)]]^2}{4} \right] = 39.28 \cdot \text{in}^3$$

Elastic modulus about x axis

$$S_x := \frac{\left[ (bf) \cdot \frac{(d)^3}{12} \right] - \left[ [(bf) - (twc)] \cdot \frac{[(d) - [2 \cdot (tfc)]]^3}{12} \right]}{(d) \cdot 0.5} = 33.12 \cdot \text{in}^3$$

Torsion constant

$$J := \frac{\left[ 2 \cdot (bf) \cdot (tfc)^3 \right] + \left[ [(d) - (tfc)] \cdot (twc)^3 \right]}{3} = 0.94 \cdot \text{in}^4$$

Moment of Inertia about external edge  
of web parallel to y axis

$$I_{y0} := \left[ [(d) - [2 \cdot (tfc)]] \cdot \frac{(twc)^3}{3} \right] + \left[ (bf)^3 \cdot (tfc) \cdot \frac{2}{3} \right] = 23.17 \cdot \text{in}^4$$

Cross sectional area

$$A_c := [2 \cdot (bf) \cdot (tfc)] + [(d) - [2 \cdot (tfc)]] \cdot (twc) = 9.2 \cdot \text{in}^2$$



Client IPC & MIMC Job Number 11215702 Sheet \_\_\_\_\_  
Project San Jacinto River Waste Pits Site Sheets By I.Goel Date 06/03/2022  
Subject Waler Section & Splice Connection Design Calculation Checked By S.Chilka Date 06/03/2022

Distance of centroid from external edge  
of web

$$x_c := \frac{\left[ \left[ (d) - [2 \cdot (tfc)] \right] \cdot \frac{(twc)^2}{2} \right] + \left[ (bf)^2 \cdot (tfc) \right]}{A_c} = 1.09 \cdot \text{in}$$

Moment of inertia about y axis

$$I_y := I_{y0} - (A_c \cdot x_c^2) = 12.21 \cdot \text{in}^4$$

Distance between flange centroids

$$h_o := (d) - (tfc) = 11.35 \cdot \text{in}$$

Warping torsional constant

$$C_w := \frac{\left[ (tfc) \cdot (bf)^3 \cdot [(d) - (tfc)]^2 \right] \cdot \left[ [3 \cdot (bf) \cdot (tfc)] + [2 \cdot (twc) \cdot [(d) - (tfc)]] \right]}{12 \cdot \left[ [6 \cdot (bf) \cdot (tfc)] + [(twc) \cdot [(d) - (tfc)]] \right]}$$

$$C_w = 316.03 \cdot \text{in}^6$$

radius of gyration about y axis

$$r_y := \sqrt{\frac{I_y}{A_c}} = 1.15 \cdot \text{in}$$

Overstrength factor for flexure

$$\Omega_f := 1.67$$

Overstrength factor for shear

$$\Omega_v := 1.67$$

## Classification of sections for local buckling - Section B4.1

### Classification of flanges in flexure - Table B4.1b (case 10)

Width - to - Thickness Ratio for flange

$$a_f := \frac{bf}{tfc} = 5.75$$



Client IPC & MIMC Job Number 11215702 Sheet \_\_\_\_\_  
 Project San Jacinto River Waste Pits Site Sheets By I.Goel Date 06/03/2022  
 Subject Waler Section & Splice Connection Design Calculation Checked By S.Chilka Date 06/03/2022

Limiting width to thickness ratio for compact flange section about major/minor axis

$$\lambda_{cf} := 0.38 \cdot \sqrt{\frac{E}{F_y}} = 10.79$$

Limiting width to thickness ratio for non compact flange section about major/minor axis

$$\lambda_{nf} := 1 \sqrt{\frac{E}{F_y}} = 28.38$$

#### Classification of web in flexure - Table B4.1b (case 15)

Width - to - Thickness Ratio for web

$$a_w := \frac{(d) - [2 \cdot (k - 2tc)]}{twc} = 23.47$$

Limiting width to thickness ratio for compact web section about major/minor axis

$$\lambda_{cw} := 3.76 \cdot \sqrt{\frac{E}{F_y}} = 106.72$$

Limiting width to thickness ratio for non compact web section about major/minor axis

$$\lambda_{nw} := 5.7 \sqrt{\frac{E}{F_y}} = 161.78$$

$$cn_{ff} := \begin{cases} \text{"Compact flange"} & \text{if } a_f \leq \lambda_{cf} & = \text{"Compact flange"} \\ \text{"Non compact flange"} & \text{if } \lambda_{cf} \leq a_f \leq \lambda_{nf} \\ \text{"Slender flange"} & \text{otherwise} \end{cases}$$

$$cn_{wf} := \begin{cases} \text{"Compact web"} & \text{if } a_w \leq \lambda_{cw} & = \text{"Compact web"} \\ \text{"Non compact web"} & \text{if } \lambda_{cw} \leq a_w \leq \lambda_{nw} \\ \text{"Slender flange web"} & \text{otherwise} \end{cases}$$

#### Allowable Stress Shear Design - Chapter G

Web area

$$A_w := (d) \cdot (twc) = 4.83 \cdot \text{in}^2$$

Web plate buckling coefficient

$$K_v := 5.34$$



Client IPC & MIMC Job Number 11215702 Sheet \_\_\_\_\_  
 Project San Jacinto River Waste Pits Site Sheets By I.Goel Date 06/03/2022  
 Subject Waler Section & Splice Connection Design Calculation Checked By S.Chilka Date 06/03/2022

$$r := 1.1 \cdot \left( K_v \cdot \frac{E}{F_y} \right)^{\frac{1}{2}} = 72.15$$

$$r1 := \frac{(d) - [2 \cdot (tfc)]}{twc} = 26.57$$

Web shear coefficient, Eq G2-3  
and Eq G2-4

$$Cv1 := \begin{cases} 1 & \text{if } r \geq r1 \\ \frac{r}{r1} & \text{if } r < r1 \end{cases}$$

$$Cv1 = 1$$

Nominal shear strength, Eq G2-1

$$Vn := 0.6 \cdot Cv1 \cdot Aw \cdot Fy = 104.33 \cdot \text{kip}$$

Allowable shear strength

$$vc := \frac{Vn}{\Omega_v} = 62.47 \cdot \text{kip}$$

Check for shear strength

$$\text{Checkvc} := \begin{cases} \frac{Vd}{vc} & \text{if } vc \geq Vd \\ \text{"Revise waler section"} & \text{if } vc < Vd \end{cases}$$

$$\text{Checkvc} = 0.62$$

## Allowable Stress Flexure design about major axis - Chapter F

### Yielding - Section F2.1

Nominal flexural strength for yielding, Eq F2-1

$$Mnyld := Fy \cdot Zx = 117.83 \cdot \text{kip} \cdot \text{ft}$$



Client IPC & MIMC Job Number 11215702 Sheet \_\_\_\_\_  
Project San Jacinto River Waste Pits Site Sheets By I.Goel Date 06/03/2022  
Subject Waler Section & Splice Connection Design Calculation Checked By S.Chilka Date 06/03/2022

### Lateral Torsional Buckling - Section F2.2

Unbraced length  $L_b := S_{rod} \cdot 2 = 120 \cdot \text{in}$

Limiting unbraced length for yielding Eq F2-5  $L_p := 1.76 \cdot r_y \cdot \sqrt{\frac{E}{F_y}} = 57.55 \cdot \text{in}$

Eq F2-8b  $cf := \left(\frac{h_o}{2}\right) \cdot \sqrt{\frac{I_y}{C_w}} = 1.12$

Eq F2-7  $r_{ts} := \sqrt{\frac{\sqrt{I_y \cdot C_w}}{S_x}} = 1.37 \cdot \text{in}$

Eq F2-6 
$$L_r := 1.95 \cdot r_{ts} \cdot \frac{E \cdot \sqrt{\left(\frac{J}{S_x \cdot h_o} + \left(\frac{J}{S_x \cdot h_o}\right)^2 + 6.76 \cdot \left(0.7 \cdot \frac{F_y}{E}\right)^2}}{(0.7 \cdot F_y)} = 245.54 \cdot \text{in}$$

From SAP2000 analysis, for calculation of  $C_b$  ( $L_p < L_b \leq L_r$ )

Moment at quarter point of unbraced segment  $M_a := 33.3 \text{kip} \cdot \text{ft}$

Moment at center line of unbraced segment  $M_b := 79.4 \text{kip} \cdot \text{ft}$

Moment at three quarter point of unbraced segment  $M_c := 33.3 \text{kip} \cdot \text{ft}$

Maximum moment in unbraced segment  $M_{abs} := 105.1 \text{kip} \cdot \text{ft}$



Client IPC & MIMC Job Number 11215702 Sheet \_\_\_\_\_  
Project San Jacinto River Waste Pits Site Sheets By I.Goel Date 06/03/2022  
Subject Waler Section & Splice Connection Design Calculation Checked By S.Chilka Date 06/03/2022

Plastic moment capacity

$$M_p := M_{nyld}$$

Lateral torsional buckling modification factor, Eq F1-1

$$C_b := 12.5 \cdot \frac{M_{abs}}{[(2.5 \cdot M_{abs}) + (3 \cdot M_a) + (4 \cdot M_b) + (3 \cdot M_c)]} = 1.68$$

Nominal flexural strength for lateral torsional buckling - Eq F2-2

$$M_{ntlb} := C_b \cdot \left[ M_p - (M_p - 0.7 \cdot F_y \cdot S_x) \cdot \frac{(L_b - L_p)}{(L_r - L_p)} \right]$$

$$M_{ntlb} = 171.42 \cdot \text{kip} \cdot \text{ft}$$

Nominal flexural strength

$$M_n := \min(M_{nyld}, M_{ntlb}) = 117.83 \cdot \text{kip} \cdot \text{ft}$$

Design flexure strength

$$m_c := \frac{M_n}{\Omega_f} = 70.56 \cdot \text{kip} \cdot \text{ft}$$

Check for flexural strength

$$\text{Check}_{mc} := \begin{cases} \frac{M_d}{m_c} & \text{if } m_c \geq M_d \\ \text{"Revise waler section"} & \text{if } m_c < M_d \end{cases}$$

$$\text{Check}_{mc} = 0.74$$

## Deflection Check

Limiting Deflection

$$L_{ld} := \frac{L_b}{360} = 0.33 \cdot \text{in}$$



Client IPC & MIMC Job Number 11215702 Sheet \_\_\_\_\_  
Project San Jacinto River Waste Pits Site Sheets By I.Goel Date 06/03/2022  
Subject Waler Section & Splice Connection Design Calculation Checked By S.Chilka Date 06/03/2022

Maximum deflection from SAP2000 analysis

$$L_{md} := 0.19\text{in}$$

Demand to Capacity Ratio

$$\text{Check}_d := \begin{cases} \frac{L_{md}}{L_{ld}} & \text{if } L_{ld} \geq L_{md} \\ \text{"Revise unbraced length"} & \text{if } L_{ld} < L_{md} \end{cases}$$

$$\text{Check}_d = 0.57$$

### Bolted Splice Plate Connection Design for Waler, Allowable Stress Design - AISC 360-16

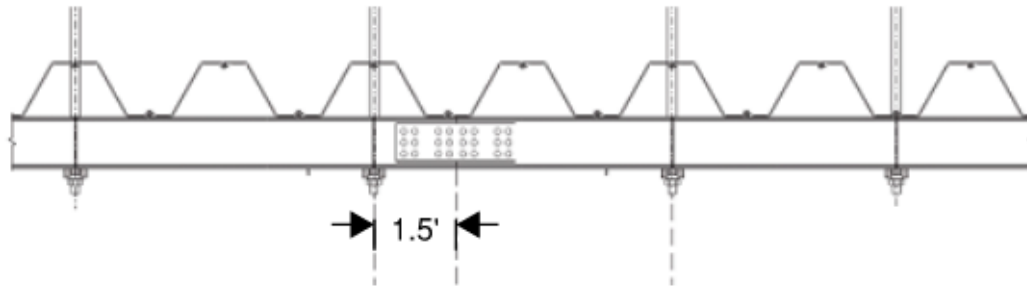

From SAP2000 analysis, point of zero moment in typical span for case 1 is ~1.2' and for case 2 is ~1.7' from tie rod anchorage. Point of splice connection for design is 1.5' from tie rod anchorage.

### Resultant Web Force at Point of Splice Connection

Bending moment demand at point of splice, from SAP2000 analysis

$$M_{sd} := 12.9\text{kip}\cdot\text{ft}$$

Horizontal force in web due to moment at point of splice

$$H_w := \frac{M_{sd} \cdot 4}{[d - [2 \cdot (k - 2tc)]]} = 65.56\text{kip}$$



Client IPC & MIMC Job Number 11215702 Sheet \_\_\_\_\_  
 Project San Jacinto River Waste Pits Site Sheets By I.Goel Date 06/03/2022  
 Subject Waler Section & Splice Connection Design Calculation Checked By S.Chilka Date 06/03/2022

Resultant web force at point of splice connection  $V_r := \sqrt{Vd^2 + H_w^2} = 76 \cdot \text{kip}$

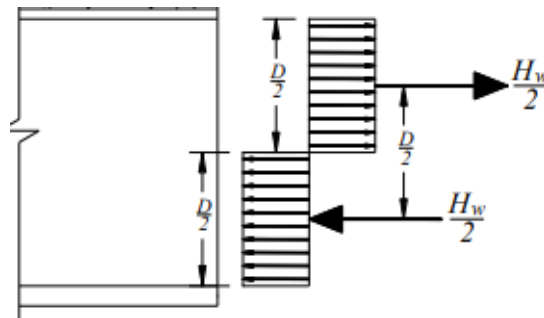

$$\text{Web Moment} = \frac{H_w \left( \frac{D}{2} \right)}{2}$$

$$H_w = \frac{\text{Web Moment}}{D/4}$$

### Factored shear resistance of bolts in shear

No of shear planes

$N_s := 1$

Section J3, Table J3.2

Using HDG Group A, A325 bolts

Nominal shear stress when threads are not excluded from shear planes

$F_{nv} := 54 \text{ksi}$

Taking 1.25" nominal diameter bolt

Bolt nominal diameter

$db := 1.25 \text{in}$

Nominal unthreaded body area of bolt

$A_b := 3.14 \cdot (db)^2 \cdot 0.25 = 1.23 \cdot \text{in}^2$

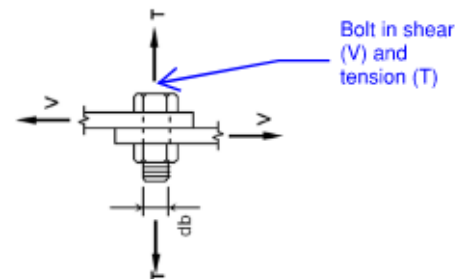



Client IPC & MIMC Job Number 11215702 Sheet \_\_\_\_\_  
 Project San Jacinto River Waste Pits Site Sheets By I.Goel Date 06/03/2022  
 Subject Waler Section & Splice Connection Design Calculation Checked By S.Chilka Date 06/03/2022

Nominal shear strength of bolt  $R_n := F_{nv} \cdot A_b \cdot N_s = 66.23 \cdot \text{kip}$

Overstrength factor  $\Omega_b := 2$

Allowable shear strength of bolt  $R_r := \frac{R_n}{\Omega_b} = 33.12 \cdot \text{kip}$

No of bolts required on each side of the web splice  $N_b := \frac{V_r}{R_r} = 2.29$

No of bolts provided on each side of the web splice  **$N_f := 6$**

No of bolt columns in connection pattern along the length of splice plate  **$N_r := 3$**

### Bolt Connection Pattern

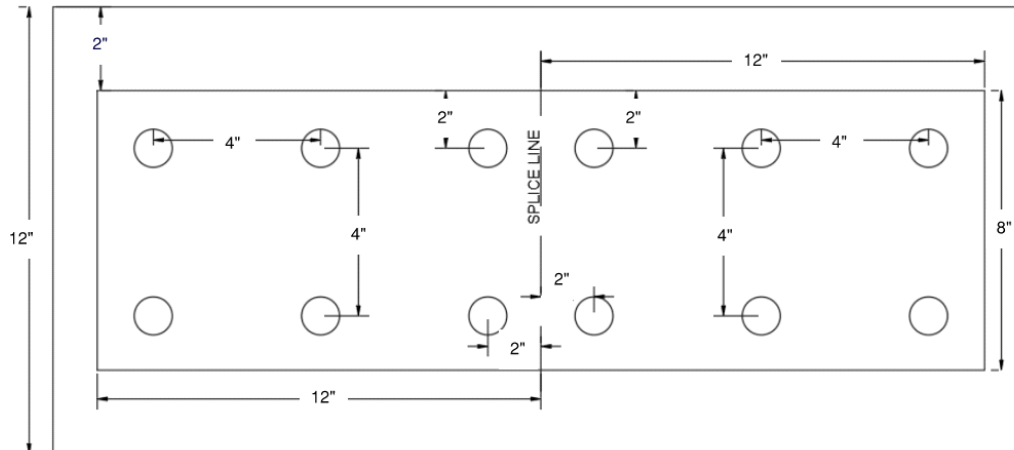

Table J3.3, for 1.25" bolt dia, standard hole dia is 1.375"

Hole diameter  **$dbh := 1.375 \text{in}$**



Client IPC & MIMC Job Number 11215702 Sheet \_\_\_\_\_  
Project San Jacinto River Waste Pits Site Sheets By I.Goel Date 06/03/2022  
Subject Waler Section & Splice Connection Design Calculation Checked By S.Chilka Date 06/03/2022

Minimum center to center spacing allowed b/w holes, Sec J3.3  $S_{min} := \frac{8 \cdot (db)}{3} = 3.33 \cdot \text{in}$

Minimum clear spacing allowed b/w holes, Sec J3.3  $S_{cmin} := db = 1.25 \cdot \text{in}$

Table J3.4, minimum edge distance allowed for 1.25" bolt dia  $S_{emin} := 1.625 \text{in}$

**Providing a splice plate of 24"X8", 0.75" thickness for the connection**

No of splice plates in the connection  $N_{sp} := 1$

**Eq. J4-3 and J4-4, strength of elements in shear**

Depth of splice plate  $d_{sp} := 8 \text{in}$

Thickness of splice plate  $T_{wsp} := 0.75 \text{in}$

Reduced thickness of splice plate - for accounting corrosion  $tw_{sp} := T_{wsp} - tc = 0.73 \cdot \text{in}$

Gross area subject to shear  $A_{gv} := d_{sp} \cdot tw_{sp} = 5.86 \cdot \text{in}^2$

Nominal shear yielding strength  $R_{nsy} := 0.6 \cdot F_y \cdot A_{gv} \cdot N_{sp} = 126.58 \cdot \text{kip}$

Overstrength factor  $\Omega_{spcy} := 1.5$



Client IPC & MIMC Job Number 11215702 Sheet \_\_\_\_\_  
Project San Jacinto River Waste Pits Site Sheets By I.Goel Date 06/03/2022  
Subject Waler Section & Splice Connection Design Calculation Checked By S.Chilka Date 06/03/2022

Allowable shear yielding strength

$$R_{rsy} := \frac{R_{nsy}}{\Omega_{spsy}} = 84.38 \cdot \text{kip}$$

Demand to Capacity Ratio

$$\text{Checksy} := \begin{cases} \frac{V_d}{R_{rsy}} & \text{if } R_{rsy} \geq V_d \\ \text{"Revise splice plate"} & \text{if } R_{rsy} < V_d \end{cases}$$

$$\text{Checksy} = 0.46$$

Net area subject to shear

$$A_{nv} := \left[ d_{sp} - \left( N_f \cdot \frac{d_{bh}}{N_r} \right) \right] \cdot t_{wsp} = 3.85 \cdot \text{in}^2$$

Nominal shear rupture strength

$$R_{nsr} := 0.6 \cdot F_u \cdot A_{nv} \cdot N_{sp} = 133.83 \cdot \text{kip}$$

Overstrength factor

$$\Omega_{spsr} := 2$$

Allowable shear rupture strength

$$R_{rsr} := \frac{R_{nsr}}{\Omega_{spsr}} = 66.91 \cdot \text{kip}$$

Demand to Capacity ratio

$$\text{Checksr} := \begin{cases} \frac{V_d}{R_{rsr}} & \text{if } R_{rsr} \geq V_d \\ \text{"Revise splice plate"} & \text{if } R_{rsr} < V_d \end{cases}$$

$$\text{Checksr} = 0.57$$



Client IPC & MIMC Job Number 11215702 Sheet \_\_\_\_\_  
Project San Jacinto River Waste Pits Site Sheets By I.Goel Date 06/03/2022  
Subject Waler Section & Splice Connection Design Calculation Checked By S.Chilka Date 06/03/2022

### Maximum spacing and edge distance - Section J3-5

Maximum edge distance

$$S_{max} := \begin{cases} 12 \cdot \min(t_w, T_{wsp}) & \text{if } 12 \cdot \min(t_w, T_{wsp}) \leq 6 \text{ in} \\ 6 \text{ in} & \text{if } 12 \cdot \min(t_w, T_{wsp}) > 6 \text{ in} \end{cases} = 5.25 \cdot \text{in}$$

Maximum center to center longitudinal spacing  
allowed b/w holes

$$S_{max} := \begin{cases} 24 \cdot \min(t_w, T_{wsp}) & \text{if } 24 \cdot \min(t_w, T_{wsp}) \leq 12 \text{ in} \\ 12 \text{ in} & \text{if } 24 \cdot \min(t_w, T_{wsp}) > 12 \text{ in} \end{cases} = 10.5 \cdot \text{in}$$

Distance of bolt from splice plate edge

$$S_{prov} := 2 \text{ in}$$

Distance of bolt from channel section flange  
inner edge

$$S_{eprov} := S_{prov} + [(d - dsp) \cdot 0.5 - k] = 2.69 \cdot \text{in}$$

Spacing provided between bolts

$$S_{prov} := 4 \text{ in}$$

Check for bolt edge distance provided

$$S_{check} := \begin{cases} \text{"Okay"} & \text{if } S_{min} \leq \max(S_{eprov}, S_{prov}) \leq S_{max} \\ \text{"Not Okay"} & \text{otherwise} \end{cases} = \text{"Okay"}$$

Check for spacing provided between bolts

$$S_{check} := \begin{cases} \text{"Okay"} & \text{if } (\max(S_{min}, S_{min} + dbh) \leq S_{prov} \leq S_{max}) \\ \text{"Not Okay"} & \text{otherwise} \end{cases} = \text{"Okay"}$$



Client IPC & MIMC Job Number 11215702 Sheet \_\_\_\_\_  
 Project San Jacinto River Waste Pits Site Sheets By I.Goel Date 06/03/2022  
 Subject Waler Section & Splice Connection Design Calculation Checked By S.Chilka Date 06/03/2022

**Block Shear Rupture Check, Eq. J4-5**

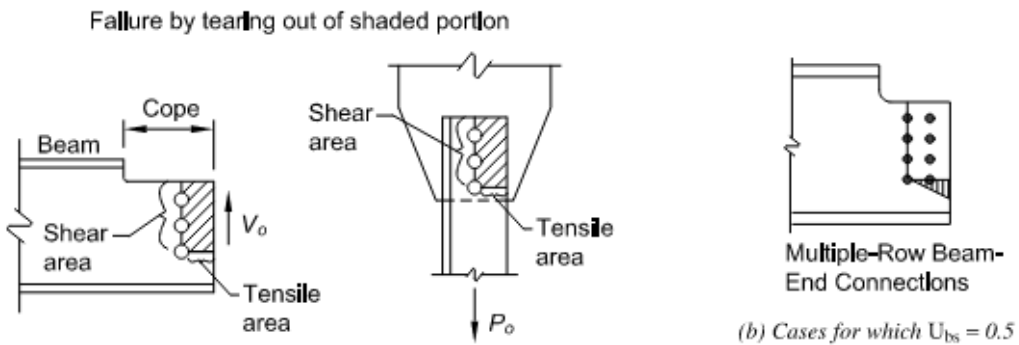

Fig. C-J4.1. Failure surface for block shear rupture limit state.

No of bolts in the outermost edge of the connection pattern which is in tension

**Nbr := 3**

Net Area resisting the tensile stress

$$A_{nt} := N_{sp} \cdot [S_{p_{rov}} + (N_{br} - 1)S_{p_{rov}} - [d_{bh} \cdot (N_{br} - 0.5)]] \cdot t_{w_{sp}} = 4.81 \cdot \text{in}^2$$

Net Area resisting the shear stress

$$A_{vn} := N_{sp} \cdot \left[ d_{sp} - S_{p_{rov}} - \left[ \left( \frac{N_f}{N_r} \right) - 0.5 \right] \cdot d_{bh} \right] \cdot t_{w_{sp}} = 2.88 \cdot \text{in}^2$$

Gross area resisting the shear stress

$$A_{gv} := N_{sp} \cdot (d_{sp} - S_{p_{rov}}) \cdot t_{w_{sp}} = 4.39 \cdot \text{in}^2$$

Nominal block shear strength

$$U_{bs} := 0.5$$

$$R_{bs} := [(0.6 \cdot F_u \cdot A_{vn}) + (U_{bs} \cdot F_u \cdot A_{nt})] = 239.77 \cdot \text{kip}$$

$$R_{nbs} := \begin{cases} R_{bs} & \text{if } R_{bs} \leq [(0.6 \cdot F_y \cdot A_{gv}) + (U_{bs} \cdot F_u \cdot A_{nt})] \\ [(0.6 \cdot F_y \cdot A_{gv}) + (U_{bs} \cdot F_u \cdot A_{nt})] & \text{if } R_{bs} > [(0.6 \cdot F_y \cdot A_{gv}) + (U_{bs} \cdot F_u \cdot A_{nt})] \end{cases} = 234.34 \cdot \text{kip}$$



Client IPC & MIMC Job Number 11215702 Sheet \_\_\_\_\_  
Project San Jacinto River Waste Pits Site Sheets By I.Goel Date 06/03/2022  
Subject Waler Section & Splice Connection Design Calculation Checked By S.Chilka Date 06/03/2022

Overstrength Factor  $\Omega_{bs} := 2$

Allowable block shear strength  $R_{rbs} := \frac{R_{nbs}}{\Omega_{bs}} = 117.17 \cdot \text{kip}$

Demand to Capacity Ratio  $\text{Check}_{bs} := \begin{cases} \frac{V_d}{R_{rbs}} & \text{if } R_{rbs} \geq V_d \\ \text{"Revise splice plate"} & \text{if } R_{rbs} < V_d \end{cases}$

$\text{Check}_{bs} = 0.33$

#### **Bearing Resistance Check, Eq. J3-6a**

Nominal bearing strength at bolt holes  $R_{nb} := 2.4 \cdot (db) \cdot t_{wsp} \cdot F_u \cdot N_f = 764.73 \cdot \text{kip}$

Overstrength Factor  $\Omega_{bh} := 2$

Allowable bearing strength at bolt holes  $R_{rb} := \frac{R_{nb}}{\Omega_{bh}} = 382.36 \cdot \text{kip}$

Demand to Capacity Ratio

$$\text{Check}_{bh} := \begin{cases} \frac{V_r}{R_{rb}} & \text{if } R_{rb} \geq V_r \\ \text{"Revise splice plate or bolts"} & \text{if } R_{rb} < V_r \end{cases} = 0.2$$

#### **Tearout Resistance Check, Eq. J3-6c**

$l_c$  for edge bolts  $l_{co} := \text{Seprov} - \left( \frac{dbh}{2} \right) = 1.31 \cdot \text{in}$



Client IPC & MIMC Job Number 11215702 Sheet \_\_\_\_\_  
Project San Jacinto River Waste Pits Site Sheets By I.Goel Date 06/03/2022  
Subject Waler Section & Splice Connection Design Calculation Checked By S.Chilka Date 06/03/2022

lc for inner bolts  $l_{ci} := S_{prov} - dbh = 2.63 \cdot \text{in}$

Inner bolts on each side of splice  $N_i := 0$

For edge bolts, nominal tearout strength at bolt holes  $R_{nto} := 1.2 \cdot t_{wsp} \cdot F_u \cdot l_{co} \cdot (N_f - N_i) = 401.48 \cdot \text{kip}$

For inner bolts, nominal tearout strength at bolt holes  $R_{nti} := 1.2 \cdot t_{wsp} \cdot F_u \cdot l_{ci} \cdot N_i = 0 \cdot \text{kip}$

Total nominal tearout strength at bolt holes  $R_{nt} := R_{nto} + R_{nti} = 401.48 \cdot \text{kip}$

Overstrength factor  $\Omega_{bt} := 2$

Allowable tearout strength at bolt holes  $R_{rt} := \frac{R_{nt}}{\Omega_{bt}} = 200.74 \cdot \text{kip}$

Demand to Capacity Ratio

$$\text{Checkth} := \begin{cases} \frac{V_r}{R_{rt}} & \text{if } R_{rt} \geq V_r \\ \text{"Revise splice plate or bolts"} & \text{if } R_{rt} < V_r \end{cases} = 0.38$$

#### Slip Resistance Check, Eq. J3-4

For class A surfaces  $\mu := 0.3$

$D_u := 1.13$

Minimum bolt pretension, Table J3.1 for Group A, A325 bolts  $T_b := 81 \text{kip}$



Client IPC & MIMC Job Number 11215702 Sheet \_\_\_\_\_  
Project San Jacinto River Waste Pits Site Sheets By I.Goel Date 06/03/2022  
Subject Waler Section & Splice Connection Design Calculation Checked By S.Chilka Date 06/03/2022

$$hf := 1$$

Nominal slip resistance of bolts

$$Rsr := Nf \cdot Ns \cdot \mu \cdot Du \cdot Tb \cdot hf = 164.75 \cdot \text{kip}$$

Overstrength Factor

$$\Omega_{sr} := 1.5$$

Allowable slip resistance of bolts

$$Rrslr := \frac{Rsr}{\Omega_{sr}} = 109.84 \cdot \text{kip}$$

Demand to Capacity Ratio

$$\text{Checkslr} := \begin{cases} \frac{V_r}{Rrslr} & \text{if } Rrslr \geq V_r \\ \text{"Revise bolts size"} & \text{if } Rrslr < V_r \end{cases} = 0.69$$

### Design Summary

**Provide rectangular splice plate of 24"X8",0.75" thickness. On each side of web splice bolted plate connection, provide 6 - 1.25" dia HDG Group A - A325 bolts.**



Client IPC & MIMC Job Number 11215702 Sheet \_\_\_\_\_  
 Project San Jacinto River Waste Pits Site Sheets By I.Goel Date 06/03/2022  
 Subject Waler Section & Splice Connection Design Calculation Checked By S.Chilka Date 06/03/2022

## Analysis Demand Load on Waler - Sec C7

Tie Rod Tension Demand Load from Analysis

$$T_{\text{roda}} := 65.6 \text{ kip}$$

Reduced to 52 kips  
 July 2024  
 This calculation is still okay.

Tie Rod Spacing

$$S_{\text{roda}} := 5 \text{ ft}$$

The tie rod spacing assumed in analysis results in large demand loads and section size for waler. To optimize section selection, tie rods will be closely spaced. Closely spaced tie rods will result in lower demand loads.

Revised Tie Rod Spacing

$$S_{\text{rod}} := 5 \text{ ft}$$

Revised Tie Rod Tension Demand

$$T_{\text{rod}} := T_{\text{roda}} \cdot \frac{S_{\text{rod}}}{S_{\text{roda}}} = 65.6 \cdot \text{kip}$$

Demand Load on waler

$$w_{\text{dl}} := \frac{T_{\text{rod}}}{S_{\text{rod}}} = 13.12 \cdot \frac{\text{kip}}{\text{ft}}$$

## Demand Load on Waler to safeguard against progressive failure

In certain situations, progressive collapse of the structure may be a consequence of an extreme condition ie. failure of a tie rod. The walling to the main wall will need to be checked to ensure that it will not collapse if the span between tie rods doubles following the loss of a tie rod.

SAP2000 analysis is used to calculate the bending moment and shear force demand on the waler for both the cases. Case 1 - without failure of a tie rod and, Case 2 - with failure of a tie rod.

For Case 1 - Continuous beam with four equal spans of length  $S_{\text{rod}}$  is analyzed

For Case 2 - Continuous beam with three spans of length  $S_{\text{rod}}$  -  $2S_{\text{rod}}$  -  $S_{\text{rod}}$  is analyzed

Waler Design is governed by the demands from Case 2



Client IPC & MIMC Job Number 11215702 Sheet \_\_\_\_\_  
Project San Jacinto River Waste Pits Site Sheets By I.Goel Date 06/03/2022  
Subject Waler Section & Splice Connection Design Calculation Checked By S.Chilka Date 06/03/2022

### Bending Moment Diagram - Case 1

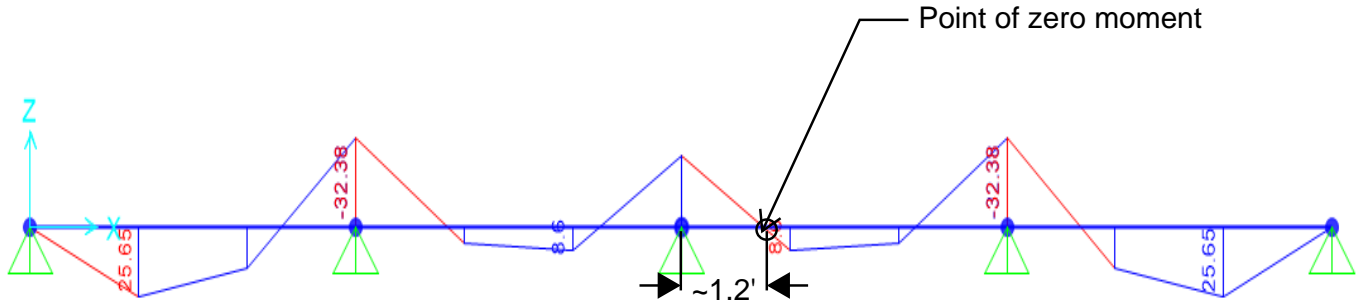

Bending Moment demand from SAP2000 -  $M_{dsap} = 32.4 \text{ Kip-ft}$

### Shear Force Diagram - Case 1

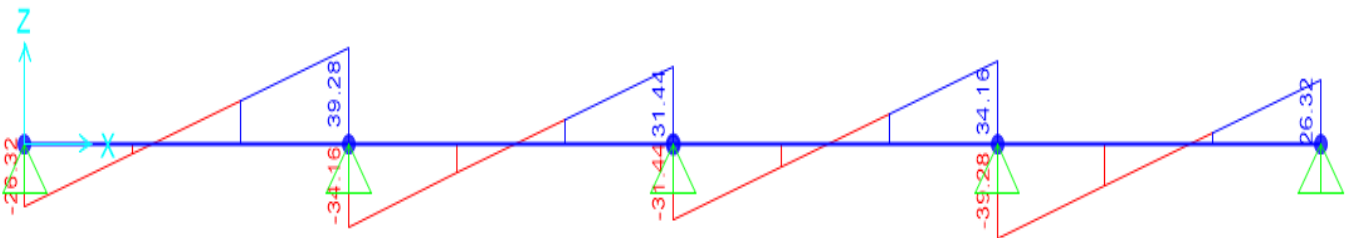

Shear Force demand from SAP2000 -  $V_{dsap} = 39.3 \text{ Kip}$



Client IPC & MIMC Job Number 11215702 Sheet \_\_\_\_\_  
Project San Jacinto River Waste Pits Site Sheets By I.Goel Date 06/03/2022  
Subject Waler Section & Splice Connection Design Calculation Checked By S.Chilka Date 06/03/2022

### Bending Moment Diagram - Case 2

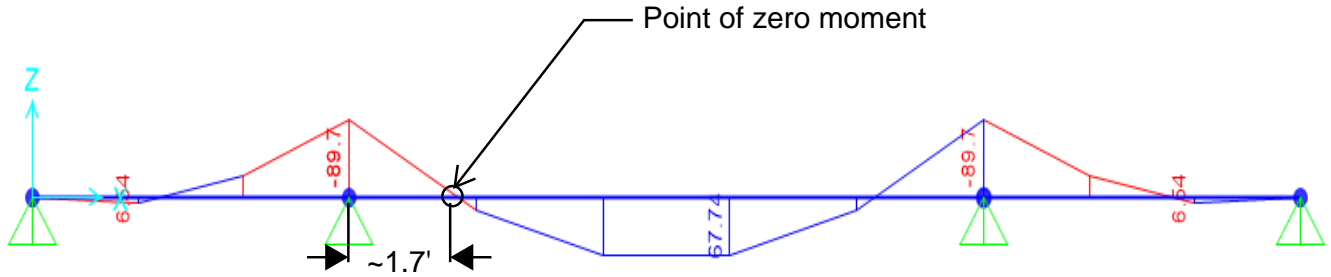

Bending Moment demand from SAP2000 -  $M_{dsap} = 89.7 \text{ Kip-ft}$

### Shear Force Diagram - Case 2

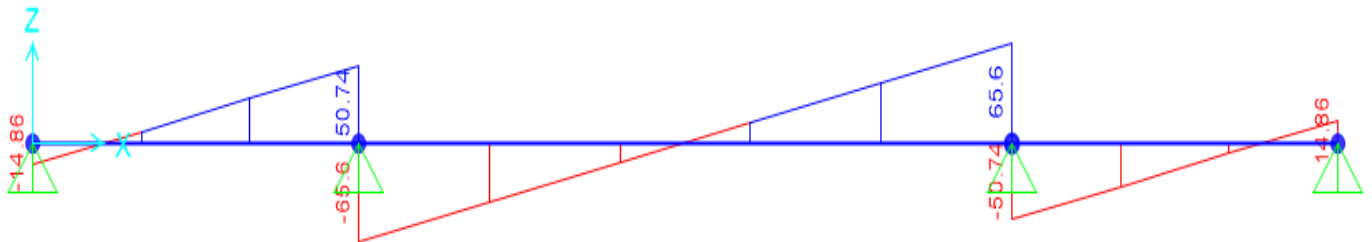

Shear Force demand from SAP2000 -  $V_{dsap} = 65.6 \text{ Kip}$



Client IPC & MIMC Job Number 11215702 Sheet \_\_\_\_\_  
Project San Jacinto River Waste Pits Site Sheets By I.Goel Date 06/03/2022  
Subject Waler Section & Splice Connection Design Calculation Checked By S.Chilka Date 06/03/2022

## Waler Cross-Section

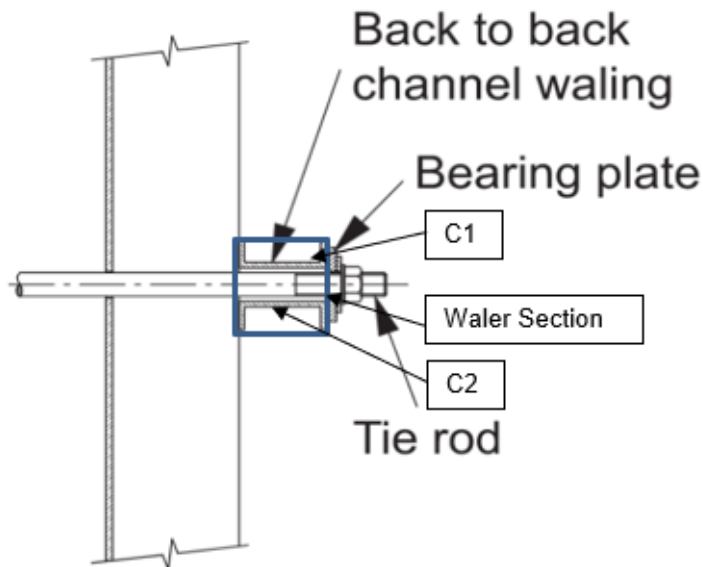

Waler is made of two channel sections C1 and C2

## Design of corroded waler section, AISC 360-16

Bending moment demand on waler from SAP2000

$$M_{dsap} := 90 \text{ kip}\cdot\text{ft}$$

Shear force demand on waler from SAP2000

$$V_{dsap} := 66 \text{ kip}$$

Bending moment demand on C1 or C2

$$M_d := \frac{M_{dsap}}{2} = 45 \text{ kip}\cdot\text{ft}$$

Shear force demand on C1 or C2

$$V_d := \frac{V_{dsap}}{2} = 33 \text{ kip}$$



Client IPC & MIMC Job Number 11215702 Sheet \_\_\_\_\_  
Project San Jacinto River Waste Pits Site Sheets By I.Goel Date 06/03/2022  
Subject Waler Section & Splice Connection Design Calculation Checked By S.Chilka Date 06/03/2022

Steel yield stress  $F_y := 36\text{ksi}$

Steel tensile stress  $F_u := 58\text{ksi}$

Modulus of Elasticity of steel  $E := 29000\text{ksi}$

Sacrificial thickness - for accounting corrosion  $t_c := 0.0175\text{in}$  Refer Basis of Design report

### Channel Section Dimensional Parameters (MC12X35)

Depth  $d := 12\text{in}$

Web thickness  $t_w := 0.4375\text{in}$

Flange thickness  $t_f := 0.6875\text{in}$

Flange width  $b_f := 3.75\text{in}$

Distance  $k := 1.3125\text{in}$

### Corroded Channel Section Dimensional Parameters (MC12X35)

Web thickness  $t_{wc} := t_w - 2t_c = 0.4\text{in}$

Flange thickness  $t_{fc} := t_f - 2t_c = 0.65\text{in}$



Client IPC & MIMC Job Number 11215702 Sheet \_\_\_\_\_  
Project San Jacinto River Waste Pits Site Sheets By I.Goel Date 06/03/2022  
Subject Waler Section & Splice Connection Design Calculation Checked By S.Chilka Date 06/03/2022

## Sectional Properties of Corroded Section

Plastic modulus about x axis

$$Z_x := \left[ (bf) \cdot \frac{(d)^2}{4} \right] - \left[ [(bf) - (twc)] \cdot \frac{[(d) - [2 \cdot (tfc)]]^2}{4} \right] = 39.28 \cdot \text{in}^3$$

Elastic modulus about x axis

$$S_x := \frac{\left[ (bf) \cdot \frac{(d)^3}{12} \right] - \left[ [(bf) - (twc)] \cdot \frac{[(d) - [2 \cdot (tfc)]]^3}{12} \right]}{(d) \cdot 0.5} = 33.12 \cdot \text{in}^3$$

Torsion constant

$$J := \frac{\left[ 2 \cdot (bf) \cdot (tfc)^3 \right] + \left[ [(d) - (tfc)] \cdot (twc)^3 \right]}{3} = 0.94 \cdot \text{in}^4$$

Moment of Inertia about external edge  
of web parallel to y axis

$$I_{y0} := \left[ [(d) - [2 \cdot (tfc)]] \cdot \frac{(twc)^3}{3} \right] + \left[ (bf)^3 \cdot (tfc) \cdot \frac{2}{3} \right] = 23.17 \cdot \text{in}^4$$

Cross sectional area

$$A_c := [2 \cdot (bf) \cdot (tfc)] + [(d) - [2 \cdot (tfc)]] \cdot (twc) = 9.2 \cdot \text{in}^2$$



Client IPC & MIMC Job Number 11215702 Sheet \_\_\_\_\_  
Project San Jacinto River Waste Pits Site Sheets By I.Goel Date 06/03/2022  
Subject Waler Section & Splice Connection Design Calculation Checked By S.Chilka Date 06/03/2022

Distance of centroid from external edge  
of web

$$x_c := \frac{\left[ \left[ (d) - [2 \cdot (tfc)] \right] \cdot \frac{(twc)^2}{2} \right] + \left[ (bf)^2 \cdot (tfc) \right]}{A_c} = 1.09 \cdot \text{in}$$

Moment of inertia about y axis

$$I_y := I_{y0} - (A_c \cdot x_c^2) = 12.21 \cdot \text{in}^4$$

Distance between flange centroids

$$h_o := (d) - (tfc) = 11.35 \cdot \text{in}$$

Warping torsional constant

$$C_w := \frac{\left[ (tfc) \cdot (bf)^3 \cdot [(d) - (tfc)]^2 \right] \cdot \left[ [3 \cdot (bf) \cdot (tfc)] + [2 \cdot (twc) \cdot [(d) - (tfc)]] \right]}{12 \cdot \left[ [6 \cdot (bf) \cdot (tfc)] + [(twc) \cdot [(d) - (tfc)]] \right]}$$

$$C_w = 316.03 \cdot \text{in}^6$$

radius of gyration about y axis

$$r_y := \sqrt{\frac{I_y}{A_c}} = 1.15 \cdot \text{in}$$

Overstrength factor for flexure

$$\Omega_f := 1.67$$

Overstrength factor for shear

$$\Omega_v := 1.67$$

## Classification of sections for local buckling - Section B4.1

### Classification of flanges in flexure - Table B4.1b (case 10)

Width - to - Thickness Ratio for flange

$$a_f := \frac{bf}{tfc} = 5.75$$



Client IPC & MIMC Job Number 11215702 Sheet \_\_\_\_\_  
 Project San Jacinto River Waste Pits Site Sheets By I.Goel Date 06/03/2022  
 Subject Waler Section & Splice Connection Design Calculation Checked By S.Chilka Date 06/03/2022

Limiting width to thickness ratio for compact flange section about major/minor axis

$$\lambda_{cf} := 0.38 \cdot \sqrt{\frac{E}{F_y}} = 10.79$$

Limiting width to thickness ratio for non compact flange section about major/minor axis

$$\lambda_{nf} := 1 \sqrt{\frac{E}{F_y}} = 28.38$$

#### Classification of web in flexure - Table B4.1b (case 15)

Width - to - Thickness Ratio for web

$$a_w := \frac{(d) - [2 \cdot (k - 2tc)]}{t_{wc}} = 23.47$$

Limiting width to thickness ratio for compact web section about major/minor axis

$$\lambda_{cw} := 3.76 \cdot \sqrt{\frac{E}{F_y}} = 106.72$$

Limiting width to thickness ratio for non compact web section about major/minor axis

$$\lambda_{nw} := 5.7 \sqrt{\frac{E}{F_y}} = 161.78$$

$$cn_{ff} := \begin{cases} \text{"Compact flange"} & \text{if } a_f \leq \lambda_{cf} & = \text{"Compact flange"} \\ \text{"Non compact flange"} & \text{if } \lambda_{cf} \leq a_f \leq \lambda_{nf} \\ \text{"Slender flange"} & \text{otherwise} \end{cases}$$

$$cn_{wf} := \begin{cases} \text{"Compact web"} & \text{if } a_w \leq \lambda_{cw} & = \text{"Compact web"} \\ \text{"Non compact web"} & \text{if } \lambda_{cw} \leq a_w \leq \lambda_{nw} \\ \text{"Slender flange web"} & \text{otherwise} \end{cases}$$

#### Allowable Stress Shear Design - Chapter G

Web area

$$A_w := (d) \cdot (t_{wc}) = 4.83 \cdot \text{in}^2$$

Web plate buckling coefficient

$$K_v := 5.34$$



Client IPC & MIMC Job Number 11215702 Sheet \_\_\_\_\_  
 Project San Jacinto River Waste Pits Site Sheets By I.Goel Date 06/03/2022  
 Subject Waler Section & Splice Connection Design Calculation Checked By S.Chilka Date 06/03/2022

$$r := 1.1 \cdot \left( K_v \cdot \frac{E}{F_y} \right)^{\frac{1}{2}} = 72.15$$

$$r1 := \frac{(d) - [2 \cdot (tfc)]}{twc} = 26.57$$

Web shear coefficient, Eq G2-3  
and Eq G2-4

$$Cv1 := \begin{cases} 1 & \text{if } r \geq r1 \\ \frac{r}{r1} & \text{if } r < r1 \end{cases}$$

$$Cv1 = 1$$

Nominal shear strength, Eq G2-1

$$V_n := 0.6 \cdot Cv1 \cdot A_w \cdot F_y = 104.33 \cdot \text{kip}$$

Allowable shear strength

$$vc := \frac{V_n}{\Omega_v} = 62.47 \cdot \text{kip}$$

Check for shear strength

$$\text{Checkvc} := \begin{cases} \frac{V_d}{vc} & \text{if } vc \geq V_d \\ \text{"Revise waler section"} & \text{if } vc < V_d \end{cases}$$

$$\text{Checkvc} = 0.53$$

## Allowable Stress Flexure design about major axis - Chapter F

### Yielding - Section F2.1

Nominal flexural strength for yielding, Eq F2-1

$$M_{nyld} := F_y \cdot Z_x = 117.83 \cdot \text{kip} \cdot \text{ft}$$



Client IPC & MIMC Job Number 11215702 Sheet \_\_\_\_\_  
Project San Jacinto River Waste Pits Site Sheets By I.Goel Date 06/03/2022  
Subject Waler Section & Splice Connection Design Calculation Checked By S.Chilka Date 06/03/2022

### Lateral Torsional Buckling - Section F2.2

Unbraced length  $L_b := S_{rod} \cdot 2 = 120 \cdot \text{in}$

Limiting unbraced length for yielding Eq F2-5  $L_p := 1.76 \cdot r_y \cdot \sqrt{\frac{E}{F_y}} = 57.55 \cdot \text{in}$

Eq F2-8b  $cf := \left(\frac{h_o}{2}\right) \cdot \sqrt{\frac{I_y}{C_w}} = 1.12$

Eq F2-7  $r_{ts} := \sqrt{\frac{\sqrt{I_y \cdot C_w}}{S_x}} = 1.37 \cdot \text{in}$

Eq F2-6  $L_r := 1.95 \cdot r_{ts} \cdot \frac{E \cdot \sqrt{\left(\frac{J \cdot cf}{S_x \cdot h_o}\right) + \left(\frac{J \cdot cf}{S_x \cdot h_o}\right)^2 + \left[6.76 \cdot \left(0.7 \cdot \frac{F_y}{E}\right)^2\right]}}{(0.7 \cdot F_y)} = 245.54 \cdot \text{in}$

From SAP2000 analysis, for calculation of  $C_b$  ( $L_p < L_b \leq L_r$ )

Moment at quarter point of unbraced segment  $M_a := 28.4 \text{kip} \cdot \text{ft}$

Moment at center line of unbraced segment  $M_b := 67.7 \text{kip} \cdot \text{ft}$

Moment at three quarter point of unbraced segment  $M_c := 28.4 \text{kip} \cdot \text{ft}$

Maximum moment in unbraced segment  $M_{abs} := 89.7 \text{kip} \cdot \text{ft}$



Client IPC & MIMC Job Number 11215702 Sheet \_\_\_\_\_  
Project San Jacinto River Waste Pits Site Sheets By I.Goel Date 06/03/2022  
Subject Waler Section & Splice Connection Design Calculation Checked By S.Chilka Date 06/03/2022

Plastic moment capacity

$$M_p := M_{nyld}$$

Lateral torsional buckling modification factor, Eq F1-1

$$C_b := 12.5 \cdot \frac{M_{abs}}{[(2.5 \cdot M_{abs}) + (3 \cdot M_a) + (4 \cdot M_b) + (3 \cdot M_c)]} = 1.68$$

Nominal flexural strength for lateral torsional buckling - Eq F2-2

$$M_{ntlb} := C_b \cdot \left[ M_p - (M_p - 0.7 \cdot F_y \cdot S_x) \cdot \frac{(L_b - L_p)}{(L_r - L_p)} \right]$$

$$M_{ntlb} = 171.52 \cdot \text{kip} \cdot \text{ft}$$

Nominal flexural strength

$$M_n := \min(M_{nyld}, M_{ntlb}) = 117.83 \cdot \text{kip} \cdot \text{ft}$$

Design flexure strength

$$m_c := \frac{M_n}{\Omega_f} = 70.56 \cdot \text{kip} \cdot \text{ft}$$

Check for flexural strength

$$\text{Check}_{mc} := \begin{cases} \frac{M_d}{m_c} & \text{if } m_c \geq M_d \\ \text{"Revise waler section"} & \text{if } m_c < M_d \end{cases}$$

$$\text{Check}_{mc} = 0.64$$

## Deflection Check

Limiting Deflection

$$L_{ld} := \frac{L_b}{360} = 0.33 \cdot \text{in}$$



Client IPC & MIMC Job Number 11215702 Sheet \_\_\_\_\_  
Project San Jacinto River Waste Pits Site Sheets By I.Goel Date 06/03/2022  
Subject Waler Section & Splice Connection Design Calculation Checked By S.Chilka Date 06/03/2022

Maximum deflection from SAP2000 analysis

$$L_{md} := 0.18\text{in}$$

Demand to Capacity Ratio

$$\text{Check}_d := \begin{cases} \frac{L_{md}}{L_{ld}} & \text{if } L_{ld} \geq L_{md} \\ \text{"Revise unbraced length"} & \text{if } L_{ld} < L_{md} \end{cases}$$

$$\text{Check}_d = 0.54$$

### Bolted Splice Plate Connection Design for Waler, Allowable Stress Design - AISC 360-16

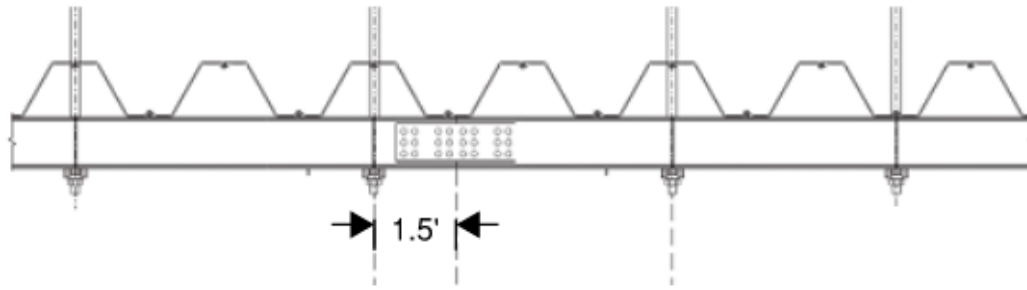

From SAP2000 analysis, point of zero moment in typical span for case 1 is ~1.2' and for case 2 is ~1.7' from tie rod anchorage. Point of splice connection for design is 1.5' from tie rod anchorage.

### Resultant Web Force at Point of Splice Connection

Bending moment demand at point of splice, from SAP2000 analysis

$$M_{sd} := 11\text{kip}\cdot\text{ft}$$

Horizontal force in web due to moment at point of splice

$$H_w := \frac{M_{sd} \cdot 4}{[d - [2 \cdot (k - 2t_c)]]} = 55.9\cdot\text{kip}$$



Client IPC & MIMC Job Number 11215702 Sheet \_\_\_\_\_  
 Project San Jacinto River Waste Pits Site Sheets By I.Goel Date 06/03/2022  
 Subject Waler Section & Splice Connection Design Calculation Checked By S.Chilka Date 06/03/2022

Resultant web force at point of splice connection  $V_r := \sqrt{Vd^2 + H_w^2} = 64.92 \cdot \text{kip}$

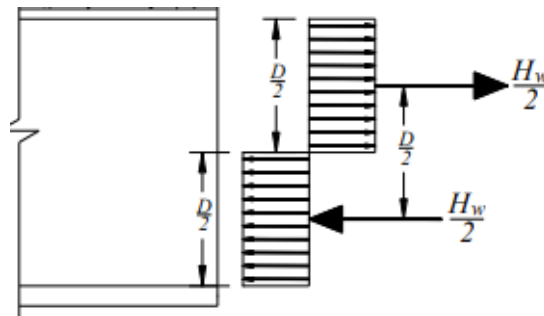

$$\text{Web Moment} = \frac{H_w \left( \frac{D}{2} \right)}{2}$$

$$H_w = \frac{\text{Web Moment}}{D/4}$$

### Factored shear resistance of bolts in shear

No of shear planes

$N_s := 1$

Section J3, Table J3.2

Using HDG Group A, A325 bolts

Nominal shear stress when threads are not excluded from shear planes

$F_{nv} := 54 \text{ksi}$

Taking 1.25" nominal diameter bolt

Bolt nominal diameter

$db := 1.25 \text{in}$

Nominal unthreaded body area of bolt

$A_b := 3.14 \cdot (db)^2 \cdot 0.25 = 1.23 \cdot \text{in}^2$

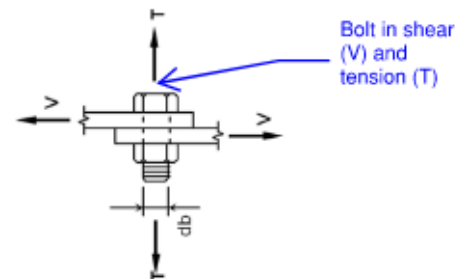



Client IPC & MIMC Job Number 11215702 Sheet \_\_\_\_\_  
 Project San Jacinto River Waste Pits Site Sheets By I.Goel Date 06/03/2022  
 Subject Waler Section & Splice Connection Design Calculation Checked By S.Chilka Date 06/03/2022

Nominal shear strength of bolt  $R_n := F_{nv} \cdot A_b \cdot N_s = 66.23 \cdot \text{kip}$

Overstrength factor  $\Omega_b := 2$

Allowable shear strength of bolt  $R_r := \frac{R_n}{\Omega_b} = 33.12 \cdot \text{kip}$

No of bolts required on each side of the web splice  $N_b := \frac{V_r}{R_r} = 1.96$

No of bolts provided on each side of the web splice  **$N_f := 6$**

No of bolt columns in connection pattern along the length of splice plate  **$N_r := 3$**

### Bolt Connection Pattern

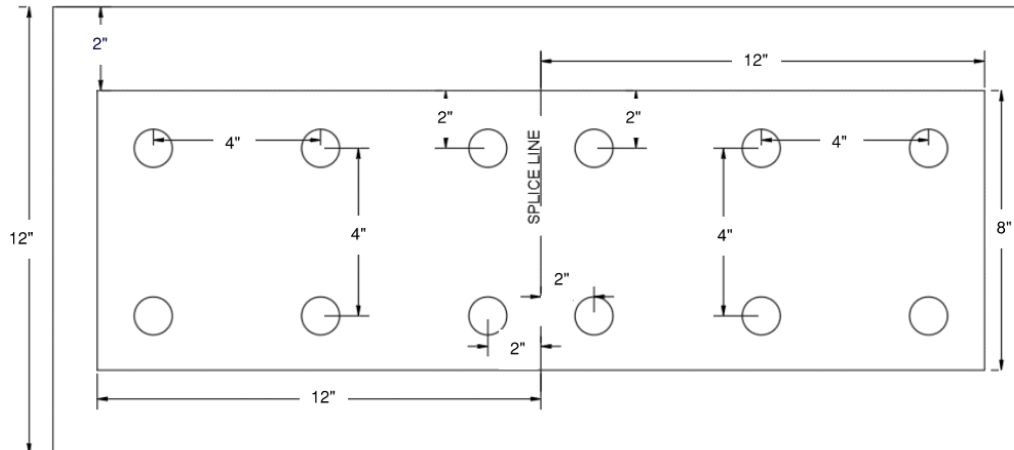

Table J3.3, for 1.25" bolt dia, standard hole dia is 1.375"

Hole diameter  **$dbh := 1.375 \text{in}$**



Client IPC & MIMC Job Number 11215702 Sheet \_\_\_\_\_  
Project San Jacinto River Waste Pits Site Sheets By I.Goel Date 06/03/2022  
Subject Waler Section & Splice Connection Design Calculation Checked By S.Chilka Date 06/03/2022

Minimum center to center spacing allowed b/w holes, Sec J3.3  $S_{min} := \frac{8 \cdot (db)}{3} = 3.33 \cdot \text{in}$

Minimum clear spacing allowed b/w holes, Sec J3.3  $S_{cmin} := db = 1.25 \cdot \text{in}$

Table J3.4, minimum edge distance allowed for 1.25" bolt dia  $S_{emin} := 1.625 \text{in}$

**Providing a splice plate of 24"X8", 0.75" thickness for the connection**

No of splice plates in the connection  $N_{sp} := 1$

**Eq. J4-3 and J4-4, strength of elements in shear**

Depth of splice plate  $d_{sp} := 8 \text{in}$

Thickness of splice plate  $T_{wsp} := 0.75 \text{in}$

Reduced thickness of splice plate - for accounting corrosion  $tw_{sp} := T_{wsp} - tc = 0.73 \cdot \text{in}$

Gross area subject to shear  $A_{gv} := d_{sp} \cdot tw_{sp} = 5.86 \cdot \text{in}^2$

Nominal shear yielding strength  $R_{nsy} := 0.6 \cdot F_y \cdot A_{gv} \cdot N_{sp} = 126.58 \cdot \text{kip}$

Overstrength factor  $\Omega_{spcy} := 1.5$



Client IPC & MIMC Job Number 11215702 Sheet \_\_\_\_\_  
Project San Jacinto River Waste Pits Site Sheets By I.Goel Date 06/03/2022  
Subject Waler Section & Splice Connection Design Calculation Checked By S.Chilka Date 06/03/2022

Allowable shear yielding strength

$$R_{rsy} := \frac{R_{nsy}}{\Omega_{spsy}} = 84.38 \cdot \text{kip}$$

Demand to Capacity Ratio

$$\text{Checksy} := \begin{cases} \frac{V_d}{R_{rsy}} & \text{if } R_{rsy} \geq V_d \\ \text{"Revise splice plate"} & \text{if } R_{rsy} < V_d \end{cases}$$

$$\text{Checksy} = 0.39$$

Net area subject to shear

$$A_{nv} := \left[ d_{sp} - \left( N_f \cdot \frac{d_{bh}}{N_r} \right) \right] \cdot t_{wsp} = 3.85 \cdot \text{in}^2$$

Nominal shear rupture strength

$$R_{nsr} := 0.6 \cdot F_u \cdot A_{nv} \cdot N_{sp} = 133.83 \cdot \text{kip}$$

Overstrength factor

$$\Omega_{spsr} := 2$$

Allowable shear rupture strength

$$R_{rsr} := \frac{R_{nsr}}{\Omega_{spsr}} = 66.91 \cdot \text{kip}$$

Demand to Capacity ratio

$$\text{Checksr} := \begin{cases} \frac{V_d}{R_{rsr}} & \text{if } R_{rsr} \geq V_d \\ \text{"Revise splice plate"} & \text{if } R_{rsr} < V_d \end{cases}$$

$$\text{Checksr} = 0.49$$



Client IPC & MIMC Job Number 11215702 Sheet \_\_\_\_\_  
Project San Jacinto River Waste Pits Site Sheets By I.Goel Date 06/03/2022  
Subject Waler Section & Splice Connection Design Calculation Checked By S.Chilka Date 06/03/2022

### Maximum spacing and edge distance - Section J3-5

Maximum edge distance

$$S_{\max} := \begin{cases} 12 \cdot \min(t_w, T_{wsp}) & \text{if } 12 \cdot \min(t_w, T_{wsp}) \leq 6 \text{ in} \\ 6 \text{ in} & \text{if } 12 \cdot \min(t_w, T_{wsp}) > 6 \text{ in} \end{cases} = 5.25 \cdot \text{in}$$

Maximum center to center longitudinal spacing  
allowed b/w holes

$$S_{\max} := \begin{cases} 24 \cdot \min(t_w, T_{wsp}) & \text{if } 24 \cdot \min(t_w, T_{wsp}) \leq 12 \text{ in} \\ 12 \text{ in} & \text{if } 24 \cdot \min(t_w, T_{wsp}) > 12 \text{ in} \end{cases} = 10.5 \cdot \text{in}$$

Distance of bolt from splice plate edge

$$S_{\text{prov}} := 2 \text{ in}$$

Distance of bolt from channel section flange  
inner edge

$$S_{\text{prov}} := S_{\text{prov}} + [(d - dsp) \cdot 0.5 - k] = 2.69 \cdot \text{in}$$

Spacing provided between bolts

$$S_{\text{prov}} := 4 \text{ in}$$

Check for bolt edge distance provided

$$S_{\text{check}} := \begin{cases} \text{"Okay"} & \text{if } S_{\min} \leq \max(S_{\text{prov}}, S_{\text{prov}}) \leq S_{\max} \\ \text{"Not Okay"} & \text{otherwise} \end{cases} = \text{"Okay"}$$

Check for spacing provided between bolts

$$S_{\text{check}} := \begin{cases} \text{"Okay"} & \text{if } (\max(S_{\min}, S_{\min} + dbh) \leq S_{\text{prov}} \leq S_{\max}) \\ \text{"Not Okay"} & \text{otherwise} \end{cases} = \text{"Okay"}$$



Client IPC & MIMC Job Number 11215702 Sheet \_\_\_\_\_  
 Project San Jacinto River Waste Pits Site Sheets By I.Goel Date 06/03/2022  
 Subject Waler Section & Splice Connection Design Calculation Checked By S.Chilka Date 06/03/2022

**Block Shear Rupture Check, Eq. J4-5**

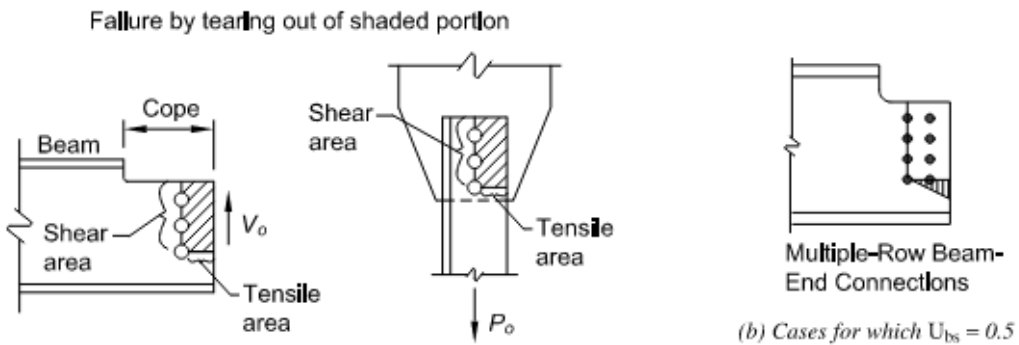

Fig. C-J4.1. Failure surface for block shear rupture limit state.

No of bolts in the outermost edge of the connection pattern which is in tension Nbr := 3

Net Area resisting the tensile stress

$$A_{nt} := N_{sp} \cdot [S_{p_{rov}} + (N_{br} - 1)S_{p_{rov}} - [d_{bh} \cdot (N_{br} - 0.5)]] \cdot t_{wsp} = 4.81 \cdot \text{in}^2$$

Net Area resisting the shear stress

$$A_{vn} := N_{sp} \cdot \left[ d_{sp} - S_{p_{rov}} - \left[ \left( \frac{N_f}{N_r} \right) - 0.5 \right] \cdot d_{bh} \right] \cdot t_{wsp} = 2.88 \cdot \text{in}^2$$

Gross area resisting the shear stress

$$A_{gv} := N_{sp} \cdot (d_{sp} - S_{p_{rov}}) \cdot t_{wsp} = 4.39 \cdot \text{in}^2$$

Nominal block shear strength

$$U_{bs} := 0.5$$

$$R_{bs} := [(0.6 \cdot F_u \cdot A_{vn}) + (U_{bs} \cdot F_u \cdot A_{nt})] = 239.77 \cdot \text{kip}$$

$$R_{nbs} := \begin{cases} R_{bs} & \text{if } R_{bs} \leq [(0.6 \cdot F_y \cdot A_{gv}) + (U_{bs} \cdot F_u \cdot A_{nt})] \\ [(0.6 \cdot F_y \cdot A_{gv}) + (U_{bs} \cdot F_u \cdot A_{nt})] & \text{if } R_{bs} > [(0.6 \cdot F_y \cdot A_{gv}) + (U_{bs} \cdot F_u \cdot A_{nt})] \end{cases} = 234.34 \cdot \text{kip}$$



Client IPC & MIMC Job Number 11215702 Sheet \_\_\_\_\_  
Project San Jacinto River Waste Pits Site Sheets By I.Goel Date 06/03/2022  
Subject Waler Section & Splice Connection Design Calculation Checked By S.Chilka Date 06/03/2022

Overstrength Factor  $\Omega_{bs} := 2$

Allowable block shear strength  $R_{rbs} := \frac{R_{nbs}}{\Omega_{bs}} = 117.17 \cdot \text{kip}$

Demand to Capacity Ratio  $\text{Check}_{bs} := \begin{cases} \frac{V_d}{R_{rbs}} & \text{if } R_{rbs} \geq V_d \\ \text{"Revise splice plate"} & \text{if } R_{rbs} < V_d \end{cases}$

$\text{Check}_{bs} = 0.28$

#### **Bearing Resistance Check, Eq. J3-6a**

Nominal bearing strength at bolt holes  $R_{nb} := 2.4 \cdot (db) \cdot t_{wsp} \cdot F_u \cdot N_f = 764.73 \cdot \text{kip}$

Overstrength Factor  $\Omega_{bh} := 2$

Allowable bearing strength at bolt holes  $R_{rb} := \frac{R_{nb}}{\Omega_{bh}} = 382.36 \cdot \text{kip}$

Demand to Capacity Ratio

$$\text{Check}_{bh} := \begin{cases} \frac{V_r}{R_{rb}} & \text{if } R_{rb} \geq V_r \\ \text{"Revise splice plate or bolts"} & \text{if } R_{rb} < V_r \end{cases} = 0.17$$

#### **Tearout Resistance Check, Eq. J3-6c**

$l_c$  for edge bolts  $l_{co} := \text{Seprov} - \left( \frac{dbh}{2} \right) = 1.31 \cdot \text{in}$



Client IPC & MIMC Job Number 11215702 Sheet \_\_\_\_\_  
 Project San Jacinto River Waste Pits Site Sheets By I.Goel Date 06/03/2022  
 Subject Waler Section & Splice Connection Design Calculation Checked By S.Chilka Date 06/03/2022

lc for inner bolts  $l_{ci} := S_{prov} - dbh = 2.63 \cdot \text{in}$

Inner bolts on each side of splice  $N_i := 0$

For edge bolts, nominal tearout strength at bolt holes  $R_{nto} := 1.2 \cdot t_{wsp} \cdot F_u \cdot l_{co} \cdot (N_f - N_i) = 401.48 \cdot \text{kip}$

For inner bolts, nominal tearout strength at bolt holes  $R_{nti} := 1.2 \cdot t_{wsp} \cdot F_u \cdot l_{ci} \cdot N_i = 0 \cdot \text{kip}$

Total nominal tearout strength at bolt holes  $R_{nt} := R_{nto} + R_{nti} = 401.48 \cdot \text{kip}$

Overstrength factor  $\Omega_{bt} := 2$

Allowable tearout strength at bolt holes  $R_{rt} := \frac{R_{nt}}{\Omega_{bt}} = 200.74 \cdot \text{kip}$

Demand to Capacity Ratio

$$\text{Checkth} := \begin{cases} \frac{V_r}{R_{rt}} & \text{if } R_{rt} \geq V_r \\ \text{"Revise splice plate or bolts"} & \text{if } R_{rt} < V_r \end{cases} = 0.32$$

**Slip Resistance Check, Eq. J3-4**

For class A surfaces  $\mu := 0.3$

$D_u := 1.13$

Minimum bolt pretension, Table J3.1 for Group A, A325 bolts  $T_b := 81 \text{kip}$



Client IPC & MIMC Job Number 11215702 Sheet \_\_\_\_\_  
Project San Jacinto River Waste Pits Site Sheets By I.Goel Date 06/03/2022  
Subject Waler Section & Splice Connection Design Calculation Checked By S.Chilka Date 06/03/2022

$$hf := 1$$

Nominal slip resistance of bolts

$$Rsr := Nf \cdot Ns \cdot \mu \cdot Du \cdot Tb \cdot hf = 164.75 \cdot \text{kip}$$

Overstrength Factor

$$\Omega_{sr} := 1.5$$

Allowable slip resistance of bolts

$$Rrslr := \frac{Rsr}{\Omega_{sr}} = 109.84 \cdot \text{kip}$$

Demand to Capacity Ratio

$$\text{Checkslr} := \begin{cases} \frac{V_r}{Rrslr} & \text{if } Rrslr \geq V_r \\ \text{"Revise bolts size"} & \text{if } Rrslr < V_r \end{cases} = 0.59$$

### Design Summary

**Provide rectangular splice plate of 24"X8",0.75" thickness. On each side of web splice bolted plate connection, provide 6 - 1.25" dia HDG Group A - A325 bolts.**



Client IPC and MIMC Job Number 11215702 Sheet \_\_\_\_\_  
Project San Jacinto River Waste Pits Site Sheets By S.Chilka Date 07-11-2024  
Subject BMP Design - Barge Impact Checked By \_\_\_\_\_ Date \_\_\_\_\_

APPENDIX I - BMP STRUCTURAL DESIGN REPORT  
**ATTACHMENT 3.2**  
**SCOUR PROTECTION BMP EXTERIOR**



# Technical Memorandum

July 8, 2024

<b>To</b>	Satish Chilka, PE	<b>Contact No.</b>	
<b>Copy to</b>		<b>Email</b>	
<b>From</b>	Aaron Holloway, PE	<b>GHD Project No.</b>	11215702
<b>Project Name</b>	San Jacinto River Waste Pits Site		
<b>Subject</b>	BMP Scour Protection		

GHD has prepared this memorandum to describe the countermeasures developed to mitigate potential scour along the proposed cofferdam (BMP). The need for scour protection was established through numerical modeling of various scenarios related to the Remedial Design (RD) and its effects on floodplain hydraulics summarized in the Hydrodynamic Modeling Report (GHD, 2024) provided as Appendix F in the 100% RD – Northern Impoundment. This study identified the potential for scour and/or sediment deposition along the outside perimeter of the BMP. The modeling results indicate that concentration of overbank flow around the BMP could generate shear stresses higher than the critical shear stress value (0.15 Pa) as shown in Figure 1, resulting in potential for scour to develop around the northern perimeter of the BMP during storm events. The shear stress values shown at the southwest corner are an artifact of the model bathymetry which doesn't capture the access road which will prevent conveyance of overbank flow through this area, reducing potential for scour at this location.

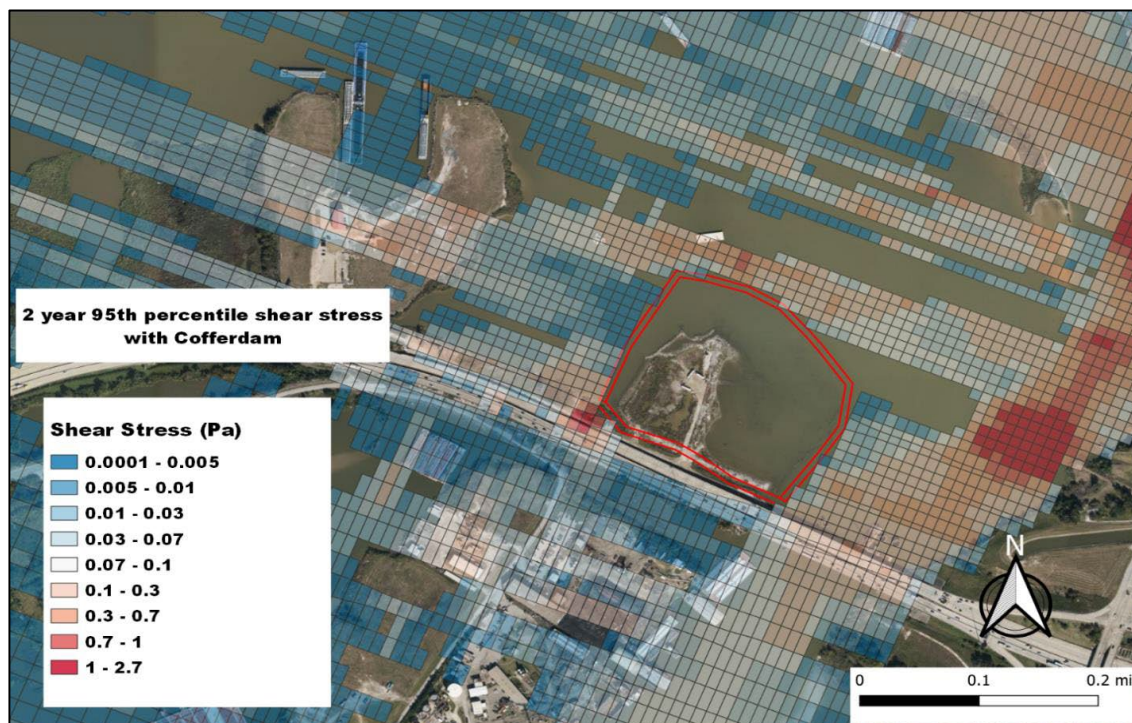

Figure 1 95<sup>th</sup>% Shear Stresses "With Cofferdam" for the 2-year Storm

194333

## Scour Protection – Riprap Scour Apron

Scour protection countermeasures were developed based on Federal Highway Administration (FHWA) guidance provided in Hydraulic Engineering Circular No. 23 (HEC-23), Bridge Scour and Stream Instability Countermeasures (Publication No. FHWA-NHI-09-111, September 2009). This document provides design guidelines for use of rock riprap to mitigate scour at bridge abutments. Although the BMP is not a bridge abutment, its influence on floodplain hydraulics is similar in that overbank flows are concentrated through a narrower section of the river resulting in localized increase in shear stress.

Design Guideline 14 was applied to the design of the rock riprap scour protection concepts. The median stone diameter for riprap scour protection is calculated based on depth, velocity and abutment geometry using the Isbash equation. Velocities around the abutment were evaluated using the 2D hydrodynamic model and compared against HEC-RAS, USGS gage data, and observations during Tropical Storm Imelda. These sources indicate maximum peak velocities would be in the 3-5 ft/s range. To account for uncertainties related to complex hydrodynamics and potential for localized flow accelerations along the BMP we applied a safety factor to the predicted maximum velocity and designed the median rock size for a velocity of 6 ft/s.

Based on this approach, the riprap scour protection apron should consist of a median stone diameter of 10 inches and an overall layer thickness of 1.5 feet. An apron width of 25 feet was selected to provide sufficient stability along the exterior perimeter of the BMP. A plan view illustrating the footprint of this scour apron is shown on Figure 2 and a typical section is shown on Figure 3.

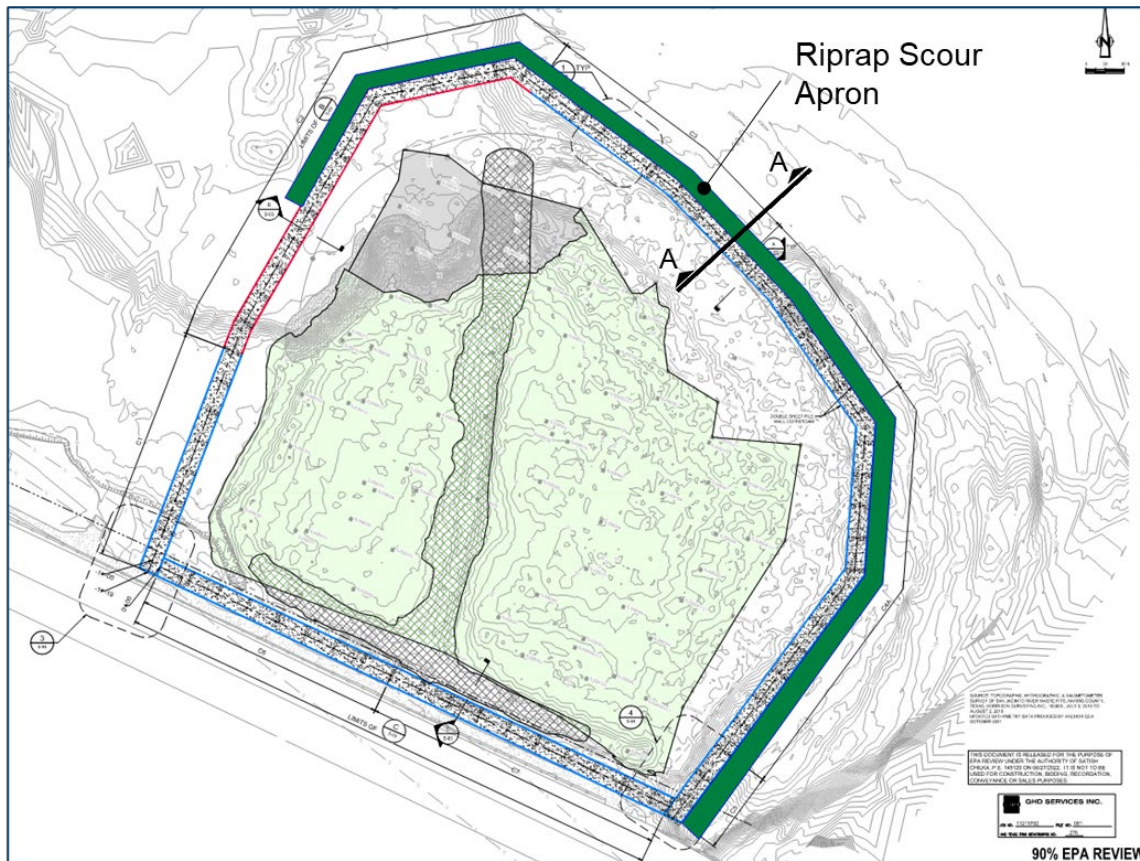
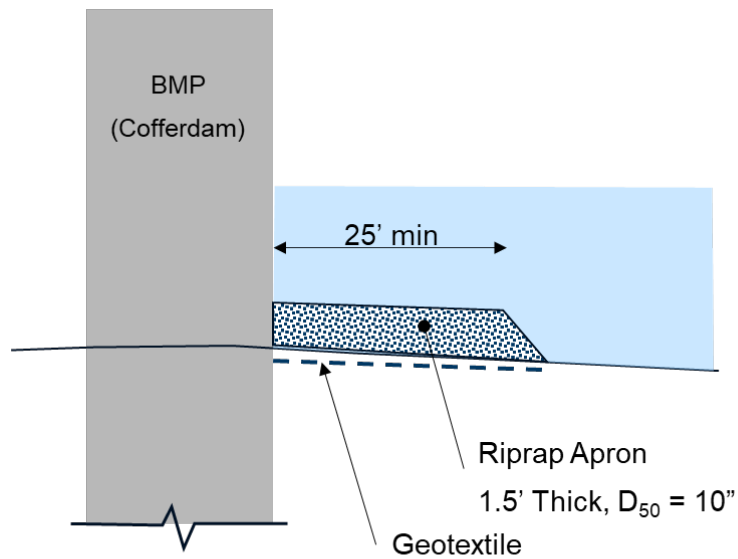

Figure 2 Plan View of Riprap Scour Apron



Typical Section A-A

Figure 3 Typical Section of Riprap Scour Apron

### Additional Considerations

We recommend use of a geotextile or engineered filter layer beneath the riprap layer to prevent the loss (erosion) of finer material beneath the riprap scour apron. In-water placement of geotextile can be challenging depending on depth and flow velocity during construction. Alternatives to geotextile may include an engineered filter layer (i.e. coarse sand/gravel or quarry run material). In addition, the use of a gabion mattress product which can be lined with geotextile prior to being filled with rock and lowered into place, could be an alternative for placement of geotextile and rip rap.



Client IPC and MIMC Job Number 11215702 Sheet \_\_\_\_\_  
Project San Jacinto River Waste Pits Site Sheets By S.Chilka Date 07-11-2024  
Subject BMP Design - Barge Impact Checked By \_\_\_\_\_ Date \_\_\_\_\_

APPENDIX I - BMP STRUCTURAL DESIGN REPORT  
**ATTACHMENT 3.3**  
**SCOUR PROTECTION BMP INTERIOR**



Client IPC and MIMC Job Number 11215702 Sheet \_\_\_\_\_  
 Project San Jacinto River Waste Pits Site Sheets By S.Chilka Date 07-11-2024  
 Subject BMP Design - Barge Impact Checked By \_\_\_\_\_ Date \_\_\_\_\_

The plunging waters can scour the material at the base of the BMP. However, once the cofferdam fills with water, the energy of the plunging waters is dissipated on contact with the water and reduces potential for scour. The water levels in the river do not rise instantaneously so the initial flood stages cause the most risk for scour.  
 The following calculations considers the river flood stage at elevation +10.5 ft (i.e., 6 inches above the top of BMP exterior wall) to estimate time to full the area within the cofferdam. The cofferdam will fill faster at a higher flood stage due to increased flow rate. Hence, this is a conservative approach to select the river stage to size the riprap size.

Available Data from Scour Protection Design Memo - Interior, 07/11/24

BMP EXT WALL ELEV (ft)	10	10	10	10	10	10
RIVER STAGE ELEV (ft)	10.1	10.5	11	11.5	12	12.5
WEIR HEAD (ft)	0.1	0.5	1	1.5	2	2.5
Q (CFS PER LF)	0.1	1.1	3	5.5	8.5	11.9
Vo (FT/S)	0.9	2.1	3	3.7	4.2	4.7

CALCULATE - Time to fill Cofferdam with River Flood Stage at Elev +10.5 ft

	RIVER STAGE EL +10.5					
	YEAR 0	YEAR 1	YEAR 2	YEAR 3	YEAR 4	YEAR 5
BMP EXT WALL ELEV	10	10	10	10	10	10
BMP LF (No Water from South Edge) <sup>1</sup>	2450	2450	2450	2450	2450	2450
BMP AREA (SF)	763500	763500	763500	763500	763500	763500
<b>RIVER STAGE</b>	<b>10.5</b>	<b>10.5</b>	<b>10.5</b>	<b>10.5</b>	<b>10.5</b>	<b>10.5</b>
WEIR HEAD	0.5	0.5	0.5	0.5	0.5	0.5
Q (CFS PER LF)	1.1	1.1	1.1	1.1	1.1	1.1
Vo (FT/S)	2.1	2.1	2.1	2.1	2.1	2.1
Q-TOTAL (CFS)	2695	2695	2695	2695	2695	2695
Q-TOTAL (CFM)	161700	161700	161700	161700	161700	161700
Q-TOTAL (CFH)	9702000	9702000	9702000	9702000	9702000	9702000
FILL RATE (MIN /FT)	4.72	4.72	4.72	4.72	4.72	4.72
AVG MUDLINE ELEV (FT) <sup>2</sup>	-5	-5	-5	-5	-5	-5
WATER FILLED TO ELEV (FT)	10	10	10	10	10	10
TOTAL WATER HEIGHT (FT)	15	15	15	15	15	15
STARTING VOL INTERIOR (CF)	11452500	11452500	11452500	11452500	11452500	11452500
ADD'L VOL EXCAVATED (CF) <sup>2</sup>	0	405000	1863000	3294000	4779000	6237000
TOTAL VOL INTERIOR (CF)	11452500	11857500	13315500	14746500	16231500	17689500
TIME TO FILL FULL INTERIOR (HR)	1.2	1.2	1.4	1.5	1.7	1.8
TIME TO FILL FULL INTERIOR (MINS)	71	73	82	91	100	109

1. Water from South Edge will shorten the duration to fill the cofferdam
2. Average mudline before beginning excavation. Mudline will change with excavation and more volume will need to fill each subsequent year. This additional volume is included as "ADD'L VOL EXCAVATED"
3. Year 0 = Before beginning excavation. Then, it is assumed excavated areas are not filled with soil or other material in subsequent season. NW corner will be filled with granular material after excavation. This will decrease volume to fill and shorten the duration to fill the cofferdam

Detailed methodology and considerations for the riprap sizing for various water levels is provided on the next page



# Technical Memorandum

November 19, 2024

<b>To</b>	Satish Chilka		
<b>Copy to</b>	Lee Lavergne		
<b>From</b>	Madeline Howell; Seth Stevens	<b>Tel</b>	+1 415 296-2056
<b>Project Name</b>	San Jacinto River Waste Pits	<b>Project No.</b>	11215702
<b>Subject</b>	San Jacinto Northern Impoundment Scour Protection		

## 1. Introduction

This memorandum outlines the scour protection design for the San Jacinto Northern Impoundment. The San Jacinto Northern Impoundment includes a cofferdam surrounding waste pits within the San Jacinto River. Analysis of water San Jacinto water levels from 1994 to 2024 have indicated that the water surface elevation in San Jacinto River has exceeded the top elevation of the designed cofferdam (10 ft) on five occasions and has risen to as high as 14 ft at the project site. Note that all these instances were outside of the planned excavation season. The current analysis studied the potential scour that could occur on the interior of the cofferdam in the event that water levels within San Jacinto River exceed the top of the cofferdam and presents mitigation measures to protect the integrity of the cofferdam.

### 1.1 Purpose

The purpose of this technical memorandum is to describe the hydraulic analysis of plunging flow over the San Jacinto Northern Impoundment cofferdam in the event that water surface elevations within the San Jacinto River exceed the top of the cofferdam, as well as to provide recommendations on the interior scour protection design.

### 1.2 Limitations

This technical memorandum has been prepared by GHD for International Paper Company (IPC) and McGinnes Industrial Maintenance Corporation (MIMC) and may only be used and relied on by IPC & MIMC for the purpose agreed between GHD and IPC & MIMC as set out in section 1.1 of this memorandum.

GHD otherwise disclaims responsibility to any person other than IPC & MIMC arising in connection with this memorandum. GHD also excludes implied warranties and conditions, to the extent legally permissible.

The services undertaken by GHD in connection with preparing this memorandum were limited to those specifically detailed in the memorandum and are subject to the scope limitations set out in the memorandum.

The opinions, conclusions and any recommendations in this memorandum are based on conditions encountered and information reviewed at the date of preparation of the memorandum. GHD has no responsibility or obligation to update this memorandum to account for events or changes occurring subsequent to the date that the memorandum was prepared.

The opinions, conclusions and any recommendations in this memorandum are based on assumptions made by GHD described in this memorandum (refer section(s) 4 of this memorandum). GHD disclaims liability arising from any of the assumptions being incorrect.

## 2. Hydraulic Analysis

The hydraulics of the flow overtopping the cofferdam were analyzed to inform the scour protection design and are discussed in the following section.

### 2.1 Cofferdam Overflow

The flow over the cofferdam was calculated using the weir equation, with a weir coefficient of 3. The flow rate (Q, per unit foot) and the flow velocity (V<sub>0</sub>) over the dam was calculated for water surface elevations within the San Jacinto River ranging from 10.1 ft to 14 ft. The results are summarized in Table 1.

Table 1: Cofferdam overflow rate and velocity.

River WSE (ft)	Weir Head (ft)	Q (cfs per LF of dam)	V <sub>0</sub> (ft/s)
10.1	0.1	0.1	0.9
10.5	0.5	1.1	2.1
11.0	1.0	3.0	3.0
11.5	1.5	5.5	3.7
12.0	2.0	8.5	4.2
12.5	2.5	11.9	4.7
13.0	3.0	15.6	5.2
13.5	3.5	19.6	5.6
14.0	4.0	24.0	6.0

Cofferdam is anticipated to fill in first two hours before river rises to these elevations

### 2.2 Hydraulics at Toe of Cofferdam

The hydraulics at the toe of the cofferdam were estimated by applying conservation of energy across the drop over the cofferdam, represented by Equation 1.

Equation 1

$$z_0 + y_0 + \frac{V_0^2}{2g} = z_1 + y_1 + \frac{V_1^2}{2g} - h_L$$

Where:

- $z_0$  = elevation of the cofferdam, 10 ft
- $y_0$  = water depth over the cofferdam, equal to weir head in Table 1
- $V_0$  = flow velocity over the dam, summarized in Table 1
- $g$  = gravitational acceleration, 32.17 ft<sup>2</sup>/s
- $z_1$  = ground elevation at the toe of the cofferdam, taken as 0 ft, -5 ft and -10 ft to represent the range of interior ground elevations
- $y_1$  = water depth at the toe of the cofferdam (ft)
- $V_1$  = flow velocity at the toe of the cofferdam, equal to Q/y<sub>1</sub> per unit foot of dam, with Q (per unit ft of dam) summarized in Table 1 (ft/s)
- $h_L$  = head loss across the drop, taken as 0 ft for free fall

The above equation was used to iteratively solve for water depth and resulting velocity at the toe of the cofferdam for a range of water surface elevations within San Jacinto River. Head loss across the drop was assumed to be negligible. The resulting calculated hydraulics at the toe of the cofferdam are summarized in Table 2 for interior ground elevations of 0 ft, -5 ft, and -10 ft. The large drop across the cofferdam leads to very high flow velocities at the toe of the cofferdam, ranging from approximately 26 ft/s to 39 ft/s.

Table 2: Hydraulics at the toe of the cofferdam.

River WSE (ft)	Q (cfs per LF of dam)	z <sub>1</sub> = 0 ft		z <sub>1</sub> = - 5 ft		z <sub>1</sub> = - 10 ft	
		y <sub>1</sub> (ft)	V <sub>1</sub> (ft/s)	y <sub>1</sub> (ft)	V <sub>1</sub> (ft/s)	y <sub>1</sub> (ft)	V <sub>1</sub> (ft/s)
10.1	0.1	0.004	25.5	0.003	31.2	0.003	36.0
10.5	1.1	0.04	26.0	0.03	31.6	0.03	36.4
11.0	3.0	0.11	26.6	0.09	32.1	0.08	36.8
11.5	5.5	0.20	27.2	0.17	32.6	0.15	37.2
12.0	8.5	0.31	27.8	0.26	33.1	0.23	37.7
12.5	11.9	0.42	28.3	0.35	33.6	0.31	38.1
13.0	15.6	0.54	28.8	0.46	34.0	0.41	38.5
13.5	19.6	0.67	29.3	0.57	34.4	0.51	38.9
14.0	24.0	0.81	29.7	0.69	34.8	0.61	39.3

## 2.3 Impact Pressure

The pressure that is exerted by the plunging flow on impact with the ground on the interior of the cofferdam was estimated to inform material selection for the scour protection. The impact pressure was calculated using the following equation, which was derived from Newton's second law of motion (Equation 2).

Equation 2

$$P = \rho V_1^2$$

Where:

- $P$  = impact pressure of the plunging flow
- $\rho$  = density of water
- $V_1$  = impact velocity, taken as the velocity at the toe of the cofferdam (see Table 2)

The impact pressures are summarized in Table 3 for interior ground elevations ( $z_1$ ) of 0 ft, - 5 ft, and -10 ft. The calculated pressures range from approximately 9 psi to approximately 21 psi.

Table 3: Summary of impact pressure results.

River WSE (ft)	Impact Pressure (psi)		
	z <sub>1</sub> = 0 ft	z <sub>1</sub> = - 5 ft	z <sub>1</sub> = - 10 ft
10.1	9	13	17
10.5	9	13	18
11.0	10	14	18
11.5	10	14	19
12.0	10	15	19
12.5	11	15	20
13.0	11	16	20
13.5	12	16	20
14.0	12	16	21

## 2.4 Minimum Length of Protection

Hydraulic jump lengths at the toe of the cofferdam were estimated to inform extents of the scour protection design. The hydraulic jump lengths were calculated using Figures 5 and 7 in the United States Bureau of Reclamation's (USBR) Engineering Monograph (EM) No. 25, *Hydraulic Design of Stilling Basins and Energy Dissipators*. These figures relate the ratio of the sequent depth ( $y_2$ ) to  $y_1$  and the ratio of the jump length ( $L_j$ ) to  $y_2$  to the Froude number ( $F_1$ ) at the toe of the cofferdam. The Froude number was calculated using Equation 3.

Equation 3

$$F_1 = V_1 / \sqrt{gy_1}$$

The resulting jump lengths are summarized in Table 4, and range from approximately 18 ft to 45 ft. Velocities associated with the sequent depths are also reported in Table 4, and range from approximately 1.6 ft/s to 3.8 ft/s, indicating minimal potential for scour. Jump lengths were not calculated for water surface elevations below 11.5 ft, since these drops experience large Froude numbers that are outside of the range of Figures 5 and 7, due to the very low flow depths. Note also that Figures 5 and 7 were developed for horizontal, rectangular stilling basins, and therefore calculated jump lengths will not apply in areas where the ground slopes down, away from the cofferdam.

Table 4: Hydraulic jump lengths and sequent depths.

River WSE (ft)	$z_1 = 0$ ft			$z_1 = -5$ ft			$z_1 = -10$ ft		
	$F_1$	$L_j$ (ft)	$V_2$ (ft/s)	$F_1$	$L_j$ (ft)	$V_2$ (ft/s)	$F_1$	$L_j$ (ft)	$V_2$ (ft/s)
11.5	10.7	18.0	1.9	14.0	19.6	1.7	17.1	20.3	1.6
12.0	8.8	22.4	2.3	11.5	24.5	2.1	14.0	26.1	2.0
12.5	7.7	26.6	2.7	10.0	29.3	2.5	12.0	31.4	2.3
13.0	6.9	30.6	3.1	8.9	33.6	2.8	10.7	36.0	2.6
13.5	6.3	34.5	3.5	8.0	37.8	3.2	9.6	40.5	3.0
14.0	5.8	38.3	3.8	7.4	41.9	3.5	8.9	44.9	3.3

The horizontal distance travelled by a particle within the upper nappe of the flow over the cofferdam was calculated using the following equations, which were derived assuming projectile motion:

Equation 4

$$\Delta x = V_x \Delta t$$

Equation 5

$$\Delta t = \sqrt{\frac{2(y_0 - z_1)}{g}}$$

Where

- $\Delta t$  = fall time in seconds
- $y_0$  = water depth over the cofferdam in feet (see Section 2.2)
- $z_1$  = ground elevation at the toe of the cofferdam in feet
- $V_x$  = horizontal velocity component in ft/s, taken as  $V_0$  (see Section 2.2)

The horizontal distance of the nappe on impact was then combined with the jump length to determine the expected extents of highly erosive flow, extending from the toe of the cofferdam. This length is the minimum length of scour protection recommended to protect the cofferdam, which are summarized in Table 5.

Same is assumed for WSE of EL +10.5

Table 5: Minimum length of scour protection.

River WSE (ft)	$\Delta x$ (ft)	$z_1 = 0$ ft		$z_1 = -5$ ft			$z_1 = -10$ ft		
		$L_j$ (ft)	Min Protection Length (ft)	$\Delta x$ (ft)	$L_j$ (ft)	Min Protection Length (ft)	$\Delta x$ (ft)	$L_j$ (ft)	Min Protection Length (ft)
11.5	3.1	18.0	21.1	3.7	19.6	23.3	4.2	20.3	24.5
12.0	3.7	22.4	26.1	4.4	24.5	28.9	5.0	26.1	31.0
12.5	4.2	26.6	30.8	4.9	29.3	34.2	5.6	31.4	37.0
13.0	4.7	30.6	35.3	5.5	33.6	39.1	6.2	36.0	42.3
13.5	5.1	34.5	39.6	6.0	37.8	43.9	6.8	40.5	47.3
14.0	5.6	38.3	43.8	6.5	41.9	48.5	7.3	44.9	52.2

## 2.5 Bench Hydraulics

The AZ42-700 double sheet pile wall cofferdam along the northwest area of the impoundment is adjacent to a 30-ft wide raised aggregate bench with a 36-inch layer of grouted riprap along the interior of the dam (see Figure 1). The top of the riprap is at elevation -4 ft with 3:1 side slopes that extend to an elevation of -7 ft. The top of the raised aggregate bench is at -7 ft, and it features 4:1 side slopes that daylight with the existing ground at elevations ranging from -12 ft to -16 ft. The hydraulics of the flow at the toe of the bench were calculated to inform scour protection design in the vicinity of the bench. The hydraulics were calculated for several water surface elevations within the San Jacinto River (10.5, 11.5 and 14.0 ft) to obtain hydraulics results for a range of conditions within the river.

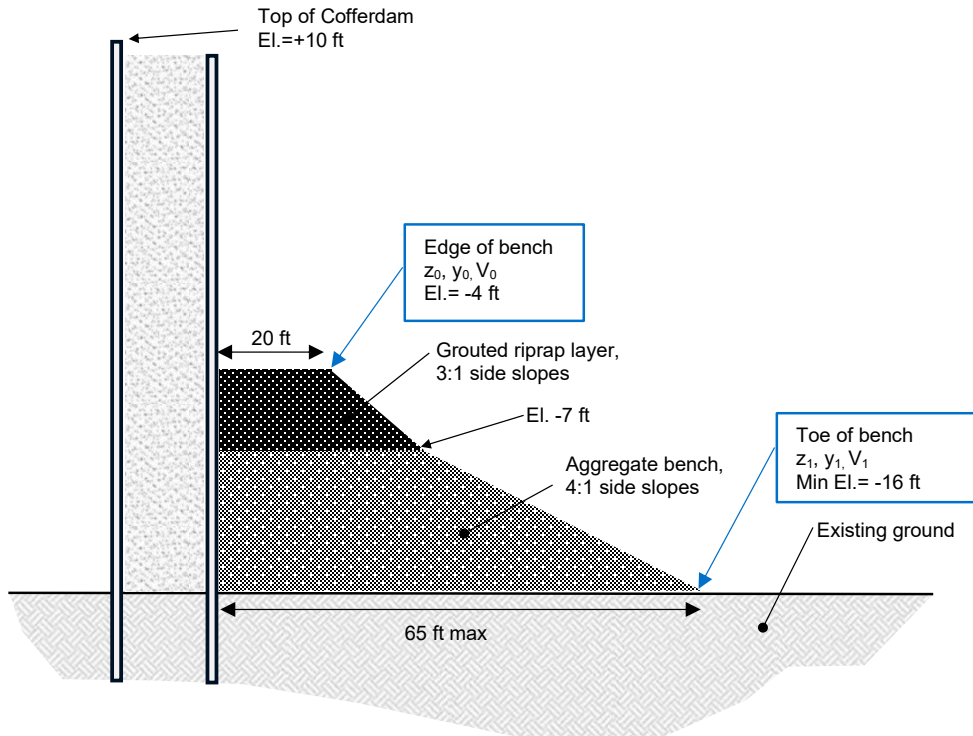

Figure 1: Diagram of raised bench (not to scale).

The bench toe hydraulics were computed using the energy balance equation (Equation 1) where  $z_0$ ,  $y_0$ , and  $V_0$ , represent the hydraulics at the edge of the 30-ft bench, and  $z_1$ ,  $y_1$ , and  $V_1$ , represent the hydraulics at the toe (see Figure 1). The hydraulics at the edge of the bench were calculated using the computed cofferdam overflow rates outlined in Table 1, assuming the flow reaches critical depth at this location (i.e.  $y_0 = y_c$ ;  $V_0 = V_c$ ). The head loss across the drop was considered in Equation 1, and was calculated using Equation 6:

Equation 6

$$h_L = \left( \frac{S_{f0} + S_{f1}}{2} \right) L$$

Where:

- $s_{f0}$  = friction slope at the edge of the bench
- $s_{f1}$  = friction slope at the toe of the bench
- $L$  = length of the bench, taken as 45 ft to represent the largest drop along the bench (from elevation - 4 ft to -16 ft), considering the 3:1 and 4:1 side slopes

The friction slope can be defined using Equation 7:

Equation 7

$$S_f = \frac{Q^2}{\left( \frac{1.486}{n} * A * R^{\frac{2}{3}} \right)^2}$$

Where:

- $Q$  = flow rate per unit length of dam (see Table 1)
- $n$  = Manning's roughness, taken as 0.045 as described below
- $R_h$  = hydraulic radius
- $A$  = flow area

The manning's roughness of the riprap, assuming  $D_{50} = 18$  inches, was calculated using the following equation developed by Rice et. al (1998):

Equation 8

$$n = 0.0292(D_{50}S_o)^{0.147}$$

Where:

- $D_{50}$  is the median rock size in mm (457 mm for 18-inch rock)
- $S_o$  is the bed slope, which was taken as 0.267 ft/ft to represent the average side slope of the bench

The results of Equation 8 indicated a manning's roughness of the 18-inch riprap of approximately 0.059. Hydraulic design manuals such as the San Diego County Hydraulic Design Manual (County of San Diego Department Works Flood Control Section, 2014) require reducing the roughness coefficient of riprap by 20% to account for grouting the rock. Applying this reduction factor yields a manning's roughness value of 0.047 for the grouted rock, which was rounded down to 0.045 for the analysis.

Once Equation 1 was used to solve for the flow depth and velocity at the toe of the bench considering head loss per Equation 6 and Equation 7, the corresponding Froude numbers were calculated using Equation 3. These hydraulics were used to calculate the hydraulic jump length using Figures 5 and 7 in USBR's EM25.

The results of the hydraulic analysis yield velocities ranging from approximately 13 ft/s to 31 ft/s at the toe of the bench, with corresponding Froude numbers of 6.2 to 9.6. The analysis results in hydraulic jump lengths

ranging from approximately 5 ft to 39 ft. Estimated hydraulics at the toe of the bench and corresponding jump lengths are summarized in Table 6.

Initial stages of flooding

Table 6: Hydraulic results and jump lengths at the toe of the bench.

River WSE	Q (cfs per LF of dam) <sup>1</sup>	y (at toe, ft) <sup>2</sup>	V (at toe, ft/s) <sup>2</sup>	F <sub>1</sub> (at toe) <sup>3</sup>	Jump Length (ft)
10.5	1.1	0.78	13.1	8.1	5.4
11.5	5.5	0.22	25.4	9.6	17.3
14.0	24.0	0.08	31.0	6.2	39.1

Notes:

1. Cofferdam overflow rate per Table 1.
2. Flow depth and velocity (Q/y) at the toe of the bench, calculated by applying energy balance across the drop, using Equation 1. Head loss, an input to Equation 1, was calculated using Equation 6 and Equation 7.
3. Froude number at the toe of the drop structure, calculated using Equation 3.

### 3. Scour Protection Design

#### 3.1 Scour Protection Material

Analysis of the cofferdam overflow hydraulics indicate very high velocities at the toe of the cofferdam (see Section 2.2), indicating the need for scour protection. These velocities are estimated to range from approximately 26 ft/s to 39 ft/s. USBR’s EM25 includes a design procedure for sizing riprap downstream of stilling basins, however, the maximum design velocity reported in Figure 165 is 18 ft/s, which corresponds with 48-inch riprap. Since the calculated velocities at the toe of the cofferdam are higher than this range, grouted riprap or concrete is recommended along the interior of the cofferdam. The maximum impact pressure of the plunging flow was calculated as approximately 21 psi (see Section 2.3), which corresponds with a water surface elevation of 14 ft within the San Jacinto River. The Texas Department of Transportation Standard Specifications Item 421 ad Departmental Materials Specifications (DMS) 4675, indicate required strengths of cement and grout of 3,000 psi or higher, depending on the concrete class. Therefore, the strength of concrete or grouted riprap is adequate to withstand the plunging flow over the cofferdam. Since the riprap will be grouted, the size of the riprap may be selected based on the availability of local rock. However, based on industry standards, riprap with a minimum median particle size (d<sub>50</sub>) of 18-inches is recommended if economically feasible. The thickness of the grouted riprap layer should be equal to twice the median particle size (d<sub>50</sub>), or the largest particle size (d<sub>100</sub>), whichever is larger.

Should it not be possible to grout the entire length of the riprap apron, loose riprap may be placed as an alternative to the grouted riprap for a portion of the riprap apron, however, some erosion of this riprap may occur during overtopping of the cofferdam. Figure 165 of USBR’s EM25 relates the flow velocity to recommended riprap size for use in sizing riprap downstream of stilling basins. Riprap diameters and maximum velocities from this figure are included in Table 7, and can be used to inform decisions on un-grouted riprap size. The estimated velocities at the toe of the cofferdam are very high, ranging from approximately 25 ft/s to 39 ft/s (see Table 2), and are outside of the range of Figure 165. Downstream of the hydraulic jump, the estimated flow velocities are low, ranging from approximately 1.6 ft/s to 3.8 ft/s (see Table 4). The flow velocities along the apron, between the toe of the cofferdam and the completion of the hydraulic jump, are difficult to estimate due to the turbulent nature of the flow.

Table 7: Riprap size vs. flow velocity, adapted from Figure 165 of USBR's EM25.

Stone Diameter (inches)	Maximum Velocity (ft/s)
6	6.4
12	9.1
18	11.1
24	12.8
30	14.2
36	15.6
42	16.7
48	18.0

## 3.2 Scour Protection Extents

The scour protection extents presented in the following section consider two design water surface elevations within the San Jacinto River (14 ft and 11.5 ft) to account for the uncertainty in the water levels within the river, the time it takes for the water to rise within the river, and the time it takes for the interior of the cofferdam to fill. The design elevation of 14 ft was selected based on analysis of the water surface elevations within the San Jacinto River from 1994 to 2024, which indicated a maximum water surface elevation of approximately 14 ft at the project site. The water surface elevation of 11.5 ft considers the fact that as the cofferdam overtops, the area within the dam will fill with water. The water within the cofferdam will aid in energy dissipation of the flow overtopping the dam, reducing the potential for scour. Note that all figures in the following section display the recommended design for a 14 ft water surface elevation within San Jacinto River.

### 3.2.1 AZ36-700 Double Sheet Pile Wall Cofferdam

#### 3.2.1.1 Eastern and Western Areas

The eastern and western portions of the cofferdam, highlighted in yellow in Figure 2, feature interior ground elevations between -10 ft and 2 ft, with most areas below 0 ft. For a design water surface elevation of 14 ft within the San Jacinto River, the length of recommended grouted riprap for this area is 55 ft, to account for the calculated hydraulic jump length and the horizontal travel distance of the plunging flow for a river water surface elevation of 14 ft and ground elevation of -10 ft (see Table 5). For a design water surface elevation of 11.5 ft within the San Jacinto River, the length of recommended grouted riprap for this area is 25 ft, per Table 5.

Additionally, a 10-ft-long loose riprap apron is recommended extending away from the grouted rock in both designs. This loose riprap is intended to help protect the grouted riprap apron from undermining and failure should scour occur at the interface between the riprap and native soil. As the native soil scours, the loose riprap will fall into the scour hole and help protect the grouted riprap. Assuming a 2:1 slope, the loose riprap could protect the grouted riprap apron from approximately 4.5 ft of vertical scour. This riprap should have a minimum median particle size ( $d_{50}$ ) of 18 inches and a minimum thickness of 36 inches. A simple diagram showing the recommended riprap apron for a design water surface elevation of 14 ft is included in Figure 3.



Figure 2: Eastern and western areas of the cofferdam, where a 55-ft grouted riprap apron and a 10-ft loose riprap apron is recommended (for river WSE=14 ft).

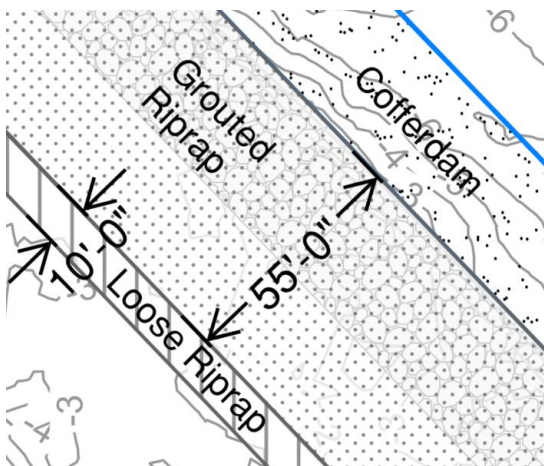

Figure 3: Recommended scour protection for eastern and western areas of the cofferdam (for river WSE=14 ft).

### 3.2.1.2 Northern Area

The northern area of the cofferdam, adjacent to the AZ42-700 double sheet pile wall, features steep sloping ground along the interior of the dam. The ground elevation along this area of the cofferdam ranges from -5 ft to -10 ft. The interior ground slopes away from the cofferdam to an elevation of -16 ft, with a maximum slope of approximately 3:1 (H:V). Additional scour protection is recommended for this area to account for the anticipated high flow velocities over these steep slopes. The minimum length of grouted riprap apron for this area is 25 ft or 55 ft, for design river water surface elevations of 11.5 ft and 14 ft, respectively. However, if the slope extends past this minimum length, the grouted riprap apron should extend to the toe of the slope. Additionally, a longer loose riprap apron of 20 ft is recommended for this area, to account for additional scour potential from flow traveling down these steep slopes. A simple diagram showing this recommended scour protection design is included in Figure 4 (for a design water surface elevation of 14 ft).

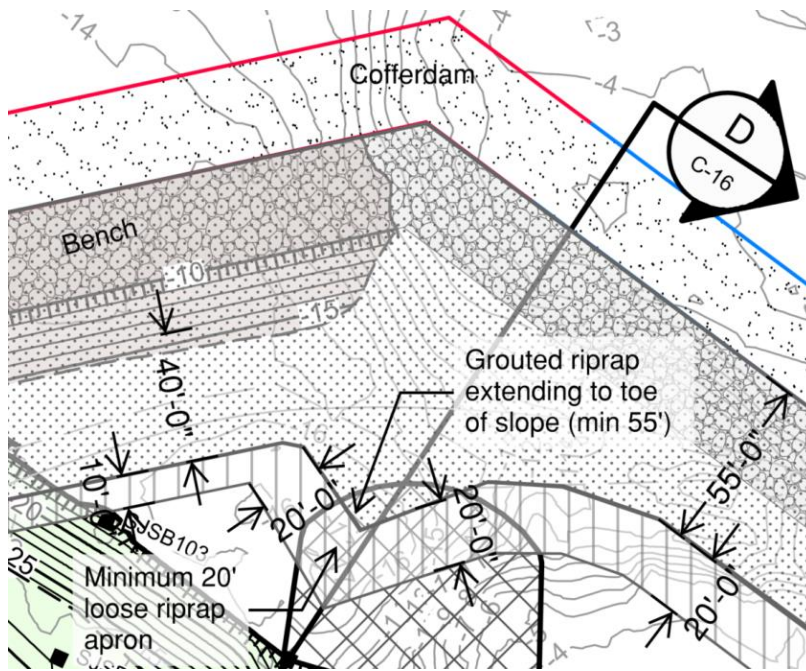

Figure 4: Recommended scour protection design for north area of the cofferdam (for river WSE= 14 ft).

### 3.2.2 AZ42-700 Pile Wall Cofferdam

The AZ42-700 Pile Wall Cofferdam is the north-east portion of the cofferdam, which features a 20-ft raised bench at an elevation of -4 ft (see Figure 1 for a diagram of the bench). The raised bench slopes down to the existing ground with side slopes varying from 3:1 to 4:1 (H:V). To ensure the stability of the raised bench, and the cofferdam, it is recommended to protect the bench and the side slopes with grouted rock. Additionally, a grouted riprap apron is recommended at the toe of the bench (where it daylight with the existing ground) to protect the existing ground from plunging flow over the bench. The recommended length for this riprap apron is 20 ft or 40 ft, for design water surface elevations within San Jacinto River of 11.5 ft and 14 ft, respectively. The length of the grouted riprap apron was designed considering the estimated hydraulic jump length for flow over the bench, summarized in Section 2.5. Similarly to the other areas of the impoundment, a 10-ft long loose riprap apron is recommended downstream of the grouted apron, to account for any additional scour at the interface between the grouted rock and the native soil. A simple diagram of the recommended scour protection is included in Figure 5 (for a design water surface elevation of 14 ft).

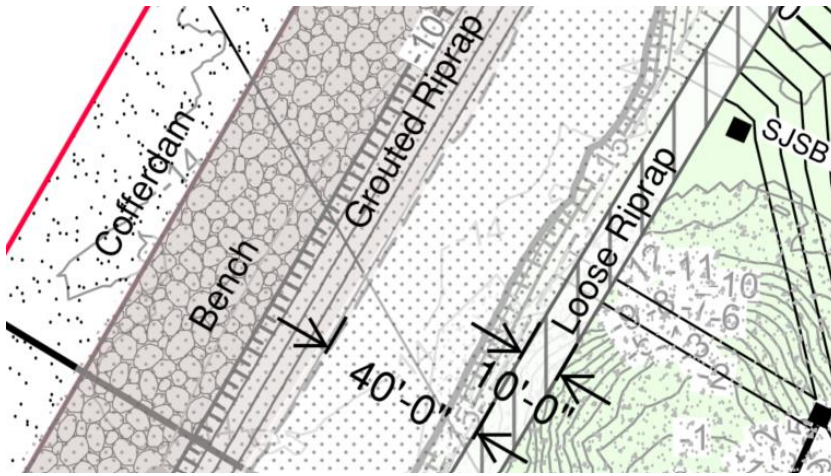

Figure 5: Recommended scour protection design for AZ42-700 double sheet pile wall cofferdam (for river WSE= 14 ft).

### 3.3 Scour Protection Maintenance

Following any event in which the cofferdam is overtopped, the riprap, grouted riprap, and/or concrete along the interior of the dam should be inspected for damage and repaired where necessary. Areas outside of the scour protection extents should also be inspected for scour/erosion, and additional scour protection may be recommended for any areas exhibiting significant scour.

## 4. Assumptions and Limitations

The scour analysis and mitigation recommendations discussed herein are based on several assumptions. The assumptions and limitations of the analysis and design, including the following:

- The calculation of flow over the cofferdam is based on the weir equation, which is a simplified approach and assumes that the velocity of the flow approaching the cofferdam is negligible. In reality, the flow in the river will likely have velocity oriented in the downstream direction which could increase or decrease the flow over the cofferdam, depending on the direction of flow relative to the cofferdam.
- The hydraulics at the toe of the cofferdam assume no head loss across the jump. While there is expected to be minimal head loss across the drop when the interior of the dam is dry, any ponded water within the cofferdam could lead to energy dissipation and reduce the flow velocities at the toe of the cofferdam.
- The hydraulic jump length calculations assume that there will be sufficient tailwater depths to force a hydraulic jump near the toe of the cofferdam. Near the beginning of the overtopping event, there may not be sufficient depth, and the flow entering the impoundment could remain supercritical.
- The hydraulic calculations assume that the flow over the cofferdam travels in the direction away from the cofferdam. As the impoundment fills with water, converging flow is expected to affect the hydraulics within the cofferdam, which cannot easily be quantified.
- The hydraulic jump calculations are based on figures in the USBR EM25, which were created based on experimental results for horizontal stilling basins. The ground within the impoundment is not flat, which may affect the flow directions, velocities, and lengths of the hydraulic jumps. Additionally, flow filling the impoundment will likely behave differently than flow within a horizontal stilling basin.
- The hydraulic jump calculations across the bench (see Section 2.5) assume that flow reaches critical depth at the edge of the bench. The flow at the edge of the bench may be supercritical, due to the high velocities experienced at the toe of the cofferdam. Thus, velocities at the toe of the bench, and resulting hydraulic jump lengths, may be higher than calculated.

- The hydraulic jump length and sequent depths could not be estimated for water surface elevations within the San Jacinto River below 11.5 ft. The flow depths at the toe of the cofferdam in these scenarios are small, leading to calculated Froude numbers that are outside of the range of the hydraulic jump length calculation methods presented in USBR's EM25. It is expected, however, that the design for higher water surface elevations within the San Jacinto River will govern.
- The flow velocities along the riprap apron between the toe of the embankment and the completion of the hydraulic jump could not be estimated due to the turbulent nature of the flow. Therefore, the size of riprap could not be estimated for a design in which only a portion of the apron is grouted.
- The analysis did not consider scour downstream of the hydraulic jump, since the flow paths and resulting velocities cannot easily be determined. It is expected that these flow velocities will be relatively low as the impoundment fills with water, however, there could be some areas that experience local scour.
- The hydraulics of flow traveling down steep segments within the impoundment, for example, along the northern section of the cofferdam (see Section 3.2.1.3), were difficult to estimate. Additional scour protection was recommended in this area, but more detailed / sophisticated modelling could improve scour protection recommendations.

The flow over the cofferdam and within its interior is three-dimensional and complex due to the vertical drop and varying ground surface within the cofferdam. The analysis performed and presented herein is simplified and based on many assumptions and limitations as noted above. A physical model or computational fluid dynamics (CFD) model could be created to reduce the limitations of the analysis. These types of three-dimensional models could provide more accurate hydraulic results on which to base the scour protection design.

## 5. Summary

This memorandum outlines the scour protection design for the San Jacinto Northern Impoundment, considering water surface elevations within the San Jacinto River of up to 14 ft and a cofferdam top elevation of 10 ft. Due to high flow velocities expected at the toe of the cofferdam from overtopping flow, a grouted riprap apron along the interior of the cofferdam is recommended. The recommended length of the grouted riprap apron varies from approximately 25 ft to approximately 95 ft, depending on the design water surface elevation within the San Jacinto River, interior ground elevation, and ground slope. A 10-ft to 20-ft-long loose riprap apron is recommended adjacent to the grouted riprap, to help protect the grouted riprap from scour at the interface of the apron and the native soil. The analysis and design discussed herein are based on several assumptions. To reduce the limitations and improve the accuracy of the analysis, a physical model or computational fluid dynamics model could be created.

## 6. References

County of San Diego Department of Public Works Flood Control Section. 2014. *San Diego County Hydraulic Design Manual*.

Rice, C. E., K. C. Kadavy, and K. M. Robinson. 1998. "Roughness of loose rock riprap on steep slopes." *J. Hydr. Engng.*, 124(2):179-185. [https://doi.org/10.1061/\(ASCE\)0733-9429\(1998\)124:2\(179\)](https://doi.org/10.1061/(ASCE)0733-9429(1998)124:2(179)).

USBR (United States Department of Interior Bureau of Reclamation). 1984. *Hydraulic Design of Stilling Basins and Energy Dissipators*. Denver, CO: USBR.



Client IPC and MIMC Job Number 11215702 Sheet \_\_\_\_\_  
Project San Jacinto River Waste Pits Site Sheets By U.Lobato Date 05-09-2025  
Subject BMP Design - Wind Load Evaluation Checked By S.Chilka Date 05-09-2025

APPENDIX I - BMP STRUCTURAL DESIGN REPORT  
**ATTACHMENT 3.4**  
**WIND LOAD EVALUATION**



Client IPC and MIMC Job Number 11215702 Sheet \_\_\_\_\_  
Project San Jacinto River Waste Pits Site Sheets By U.Lobato Date 05-09-2025  
Subject BMP Design - Wind Load Evaluation Checked By S.Chilka Date 05-09-2025

### **BMP Design - Wind Load Parametric Study Summary**

BMP structural analysis is performed for hydrostatic load from flood stage water level at El. +10ft. Analysis doesn't include wind loads. Hence, this parametric study evaluates the effect of wind loads on the BMP. The net load combining wind and hydrostatic load, without a reduction factor (0.6) on wind, is compared to the design case hydrostatic load. As the net load is lower than the design case hydrostatic load, further analytical evaluation of wind loads is not required.

Evaluation results of extreme and unusual wind load cases for different mudline elevations are presented on the following pages.



Client IPC and MIMC Job Number 11215702 Sheet \_\_\_\_\_  
 Project San Jacinto River Waste Pits Site Sheets By U.Lobato Date 05-09-2025  
 Subject BMP Design - Wind Load Evaluation Checked By S.Chilka Date 05-09-2025

**Mudline Elevation = 0ft**

**Wind Load - Extreme Case (EX)**

**Condition 1**

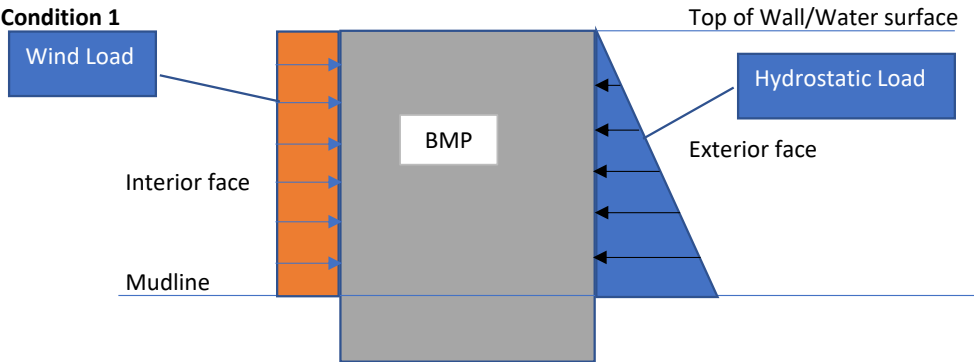

Wall	Interior	Exterior	
Top of Wall elevation	9	10	ft
Mudline elevation	0	0	ft
Top Elevation of Wind	9	0	ft
Bottom Elevation of Wind	0	0	ft
Top Elevation of Water	0	10	ft
Bottom Elevation of Water	0	0	ft

**Hydrostatic Load**

Density of water	$\rho_w$	62.4	62.4	lb/ft <sup>3</sup>
Total load on BMP	$H_{LEX1}$	0.00	3.12	kip/ L.F per unit ft length of BMP
Acting at height	$H_{1EX1}$	0.00	3.33	ft from mudline elevation

**Wind Load**

Wind pressure	$q_{z3000}$	43.87	43.87	lb/ft <sup>2</sup> Refer Basis of Design report
Total load on BMP	$W_{LEX1}$	0.39	0.00	kip/ L.F per unit ft length of BMP
Acting at height	$H_{2EX1}$	4.5	0	ft from mudline elevation

Total Load on BMP		0.39	3.12	(Hydrostatic + Wind)
<b>Net Load on BMP</b>	$N_{LEX1}$	2.73		kip/L.F (Exterior - Interior)
Acting at height	$H_{nLEX1}$	3.2		ft from mudline elevation

**Load Govern Check**

Design case hydrostatic load governs  
 Extreme Water Level (Hydrostatic) load acting on one side of the BMP is greater than the calculated net load on BMP.



Client IPC and MIMC Job Number 11215702 Sheet \_\_\_\_\_  
 Project San Jacinto River Waste Pits Site Sheets By U.Lobato Date 05-09-2025  
 Subject BMP Design - Wind Load Evaluation Checked By S.Chilka Date 05-09-2025

**Wind Load - Extreme Case (EX)**

**Condition 2**

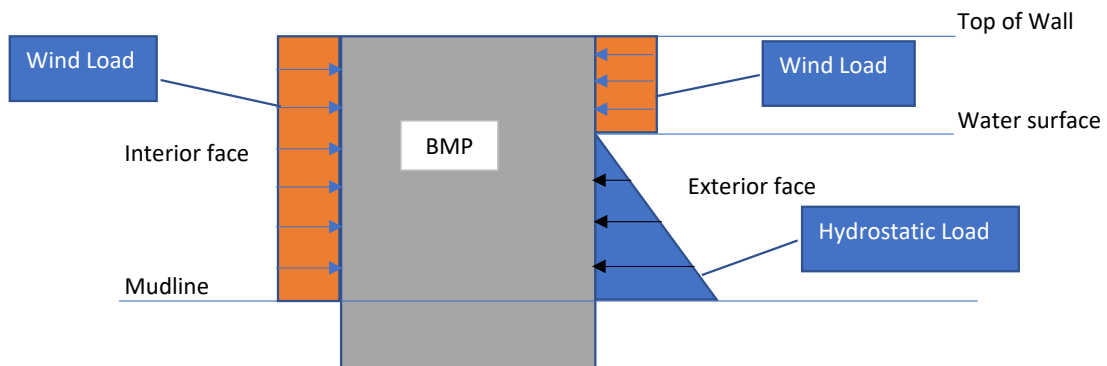

Wall	Interior	Exterior	
Top of Wall elevation	9	10	ft
Mudline elevation	0	0	ft
Top Elevation of Wind	9	10	ft
Bottom Elevation of Wind	0	5	ft
Top Elevation of Water	0	5	ft
Bottom Elevation of Water	0	0	ft

**Hydrostatic Load**

Density of water	$\rho_w$	62.4	62.4	lb/ft <sup>3</sup>
Total load on BMP	$H_{LEX2}$	0.00	0.78	kip/ L.F per unit ft length of BMP
Acting at height	$H_{1EX2}$	0.00	1.67	ft from mudline elevation

**Wind Load**

Wind pressure	$q_{z3000}$	43.87	43.87	lb/ft <sup>2</sup> Refer Basis of Design report
Total load on BMP	$W_{LEX2}$	0.39	0.22	kip/ L.F per unit ft length of BMP
Acting at height	$H_{2EX2}$	4.5	7.5	ft from mudline elevation

Total Load on BMP		0.39	1.00	(Hydrostatic + Wind)
<b>Net Load on BMP</b>	$N_{LEX2}$	0.60		kip/L.F (Exterior - Interior)
Acting at height	$H_{nLEX2}$	1.9		ft from mudline elevation

**Load Govern Check**

Design case hydrostatic load governs  
 Extreme Water Level (Hydrostatic) load acting on one side of the BMP is greater than the calculated net load on BMP.



Client IPC and MIMC Job Number 11215702 Sheet \_\_\_\_\_  
 Project San Jacinto River Waste Pits Site Sheets By U.Lobato Date 05-09-2025  
 Subject BMP Design - Wind Load Evaluation Checked By S.Chilka Date 05-09-2025

**Wind Load - Unusual Case (UN)**

**Condition 1**

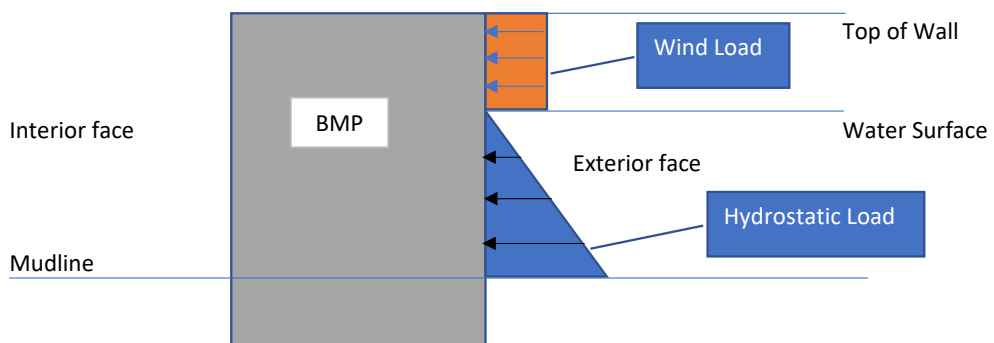

Wall	Interior	Exterior	
Top of Wall elevation	9	10	ft
Mudline elevation	0	0	ft
Top Elevation of Wind	0	10	ft
Bottom Elevation of Wind	0	5	ft
Top Elevation of Water	0	5	ft
Bottom Elevation of Water	0	0	ft

**Hydrostatic Load**

Density of water	$\rho_w$	62.4	62.4	lb/ft <sup>3</sup>
Total load on BMP	$H_{LUN1}$	0.00	0.78	kip/ L.F per unit ft length of BMP
Acting at height	$H_{1UN1}$	0.00	1.67	ft from mudline elevation

**Wind Load**

Wind pressure	$q_{z3000}$	24.89	24.89	lb/ft <sup>2</sup> Refer Basis of Design report
Total load on BMP	$W_{LUN1}$	0.00	0.12	kip/ L.F per unit ft length of BMP
Acting at height	$H_{2UN1}$	0	7.5	ft from mudline elevation

Total Load on BMP		0.00	0.90	(Hydrostatic + Wind)
<b>Net Load on BMP</b>	$N_{LUN1}$	0.90		kip/L.F (Exterior - Interior)
Acting at height	$H_{n1UN1}$	2.5		ft from mudline elevation

**Load Govern Check**

Design case hydrostatic load governs  
 Extreme Water Level (Hydrostatic) load acting on one side of the BMP is greater than the calculated net load on BMP.



Client IPC and MIMC Job Number 11215702 Sheet \_\_\_\_\_  
 Project San Jacinto River Waste Pits Site Sheets By U.Lobato Date 05-09-2025  
 Subject BMP Design - Wind Load Evaluation Checked By S.Chilka Date 05-09-2025

**Wind Load - Unusual Case (UN)**

**Condition 2**

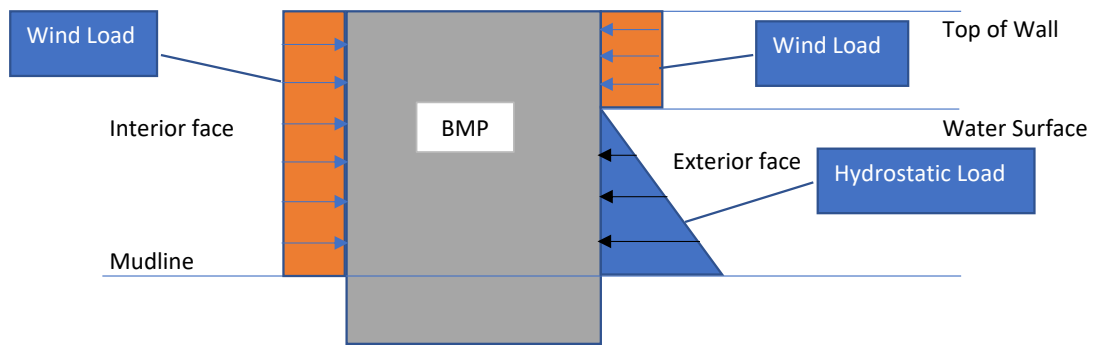

Wall	Interior	Exterior	
Top of Wall elevation	9	10	ft
Mudline elevation	0	0	ft
Top Elevation of Wind	9	10	ft
Bottom Elevation of Wind	0	5	ft
Top Elevation of Water	0	5	ft
Bottom Elevation of Water	0	0	ft

**Hydrostatic Load**

Density of water	$\rho_w$	62.4	62.4	lb/ft <sup>3</sup>
Total load on BMP	$H_{LUN2}$	0.00	0.78	kip/ L.F per unit ft length of BMP
Acting at height	$H_{1UN2}$	0.00	1.67	ft from mudline elevation

**Wind Load**

Wind pressure	$q_{z3000}$	24.89	24.89	lb/ft <sup>2</sup> Refer Basis of Design report
Total load on BMP	$W_{LUN2}$	0.22	0.12	kip/ L.F per unit ft length of BMP
Acting at height	$H_{2UN2}$	4.5	7.5	ft from mudline elevation

Total Load on BMP		0.22	0.90	(Hydrostatic + Wind)
<b>Net Load on BMP</b>	$N_{LUN2}$	0.68		kip/L.F (Exterior - Interior)
Acting at height	$H_{n1UN2}$	1.8		ft from mudline elevation

**Load Govern Check**

Design case hydrostatic load governs  
 Extreme Water Level (Hydrostatic) load acting on one side of the BMP is greater than the calculated net load on BMP.



Client IPC and MIMC Job Number 11215702 Sheet \_\_\_\_\_  
 Project San Jacinto River Waste Pits Site Sheets By U.Lobato Date 05-09-2025  
 Subject BMP Design - Wind Load Evaluation Checked By S.Chilka Date 05-09-2025

**Mudline Elevation = -10ft**

**Wind Load - Extreme Case (EX)**

**Condition 1**

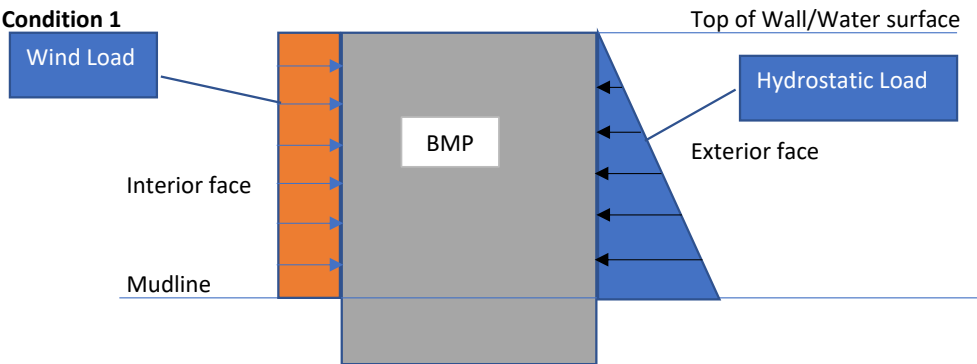

Wall	Interior	Exterior	
Top of Wall elevation	9	10	ft
Mudline elevation	-10	-10	ft
Top Elevation of Wind	9	0	ft
Bottom Elevation of Wind	0	0	ft
Top Elevation of Water	0	10	ft
Bottom Elevation of Water	0	0	ft

**Hydrostatic Load**

Density of water	$\rho_w$	62.4	62.4	lb/ft <sup>3</sup>
Total load on BMP	$H_{LEX1}$	0.00	3.12	kip/ L.F per unit ft length of BMP
Acting at height	$H_{1EX1}$	0.00	13.33	ft from mudline elevation

**Wind Load**

Wind pressure	$q_{z3000}$	43.87	43.87	lb/ft <sup>2</sup> Refer Basis of Design report
Total load on BMP	$W_{LEX1}$	0.39	0.00	kip/ L.F per unit ft length of BMP
Acting at height	$H_{2EX1}$	14.5	0	ft from mudline elevation

Total Load on BMP		0.39	3.12	(Hydrostatic + Wind)
<b>Net Load on BMP</b>	$N_{LEX1}$	2.73		kip/L.F (Exterior - Interior)
Acting at height	$H_{nlEX1}$	13.2		ft from mudline elevation

**Load Govern Check**

Design case hydrostatic load governs  
 Extreme Water Level (Hydrostatic) load acting on one side of the BMP is greater than the calculated net load on BMP.



Client IPC and MIMC Job Number 11215702 Sheet \_\_\_\_\_  
 Project San Jacinto River Waste Pits Site Sheets By U.Lobato Date 05-09-2025  
 Subject BMP Design - Wind Load Evaluation Checked By S.Chilka Date 05-09-2025

**Wind Load - Extreme Case (EX)**

**Condition 2**

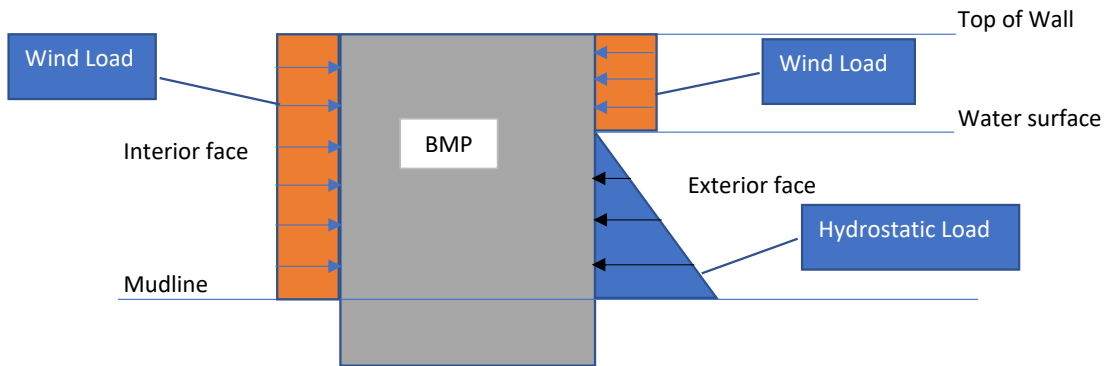

Wall	Interior	Exterior	
Top of Wall elevation	9	10	ft
Mudline elevation	-10	-10	ft
Top Elevation of Wind	9	10	ft
Bottom Elevation of Wind	0	5	ft
Top Elevation of Water	0	5	ft
Bottom Elevation of Water	0	0	ft

**Hydrostatic Load**

Density of water	$\rho_w$	62.4	62.4	lb/ft <sup>3</sup>
Total load on BMP	$H_{LEX2}$	0.00	0.78	kip/ L.F per unit ft length of BMP
Acting at height	$H_{1EX2}$	0.00	11.67	ft from mudline elevation

**Wind Load**

Wind pressure	$q_{z3000}$	43.87	43.87	lb/ft <sup>2</sup> Refer Basis of Design report
Total load on BMP	$W_{LEX2}$	0.39	0.22	kip/ L.F per unit ft length of BMP
Acting at height	$H_{2EX2}$	14.5	17.5	ft from mudline elevation

Total Load on BMP		0.39	1.00	(Hydrostatic + Wind)
<b>Net Load on BMP</b>	$N_{LEX2}$	0.60		kip/L.F (Exterior - Interior)
Acting at height	$H_{nlEX2}$	11.9		ft from mudline elevation

**Load Govern Check**

Design case hydrostatic load governs  
 Extreme Water Level (Hydrostatic) load acting on one side of the BMP is greater than the calculated net load on BMP.



Client IPC and MIMC Job Number 11215702 Sheet \_\_\_\_\_  
 Project San Jacinto River Waste Pits Site Sheets By U.Lobato Date 05-09-2025  
 Subject BMP Design - Wind Load Evaluation Checked By S.Chilka Date 05-09-2025

**Wind Load - Unusual Case (UN)**

**Condition 1**

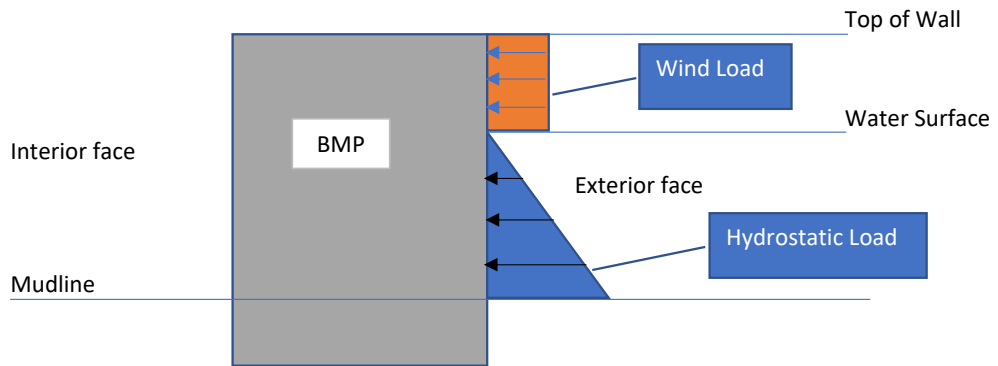

Wall	Interior	Exterior	
Top of Wall elevation	9	10	ft
Mudline elevation	-10	-10	ft
Top Elevation of Wind	0	10	ft
Bottom Elevation of Wind	0	5	ft
Top Elevation of Water	0	5	ft
Bottom Elevation of Water	0	0	ft

**Hydrostatic Load**

Density of water	$\rho_w$	62.4	62.4	lb/ft <sup>3</sup>
Total load on BMP	$H_{LUN1}$	0.00	0.78	kip/ L.F per unit ft length of BMP
Acting at height	$H_{1UN1}$	0.00	11.67	ft from mudline elevation

**Wind Load**

Wind pressure	$q_{z3000}$	24.89	24.89	lb/ft <sup>2</sup> Refer Basis of Design report
Total load on BMP	$W_{LUN1}$	0.00	0.12	kip/ L.F per unit ft length of BMP
Acting at height	$H_{2UN1}$	0	17.5	ft from mudline elevation

Total Load on BMP		0.00	0.90	(Hydrostatic + Wind)
<b>Net Load on BMP</b>	$N_{LUN1}$	0.90		kip/L.F (Exterior - Interior)
Acting at height	$H_{r1UN1}$	12.5		ft from mudline elevation

**Load Govern Check**

Design case hydrostatic load governs  
 Extreme Water Level (Hydrostatic) load acting on one side of the BMP is greater than the calculated net load on BMP.



Client IPC and MIMC Job Number 11215702 Sheet \_\_\_\_\_  
 Project San Jacinto River Waste Pits Site Sheets By U.Lobato Date 05-09-2025  
 Subject BMP Design - Wind Load Evaluation Checked By S.Chilka Date 05-09-2025

**Wind Load - Unusual Case (UN)**

**Condition 2**

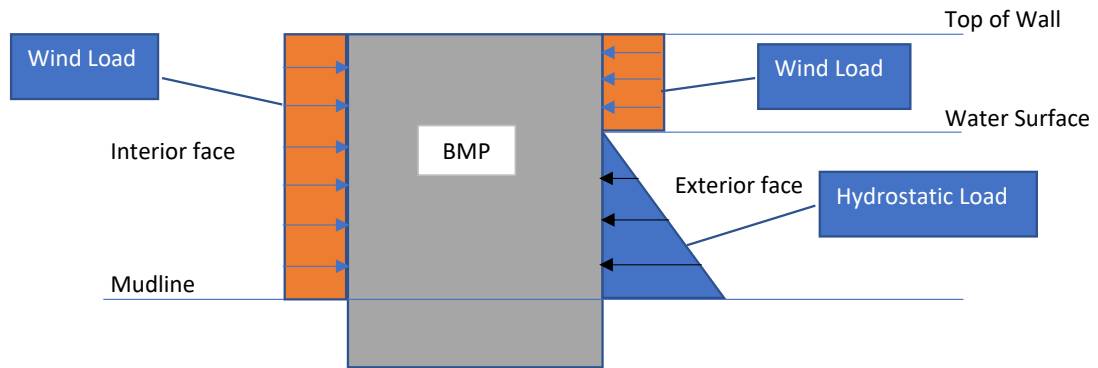

Wall	Interior	Exterior	
Top of Wall elevation	9	10	ft
Mudline elevation	-10	-10	ft
Top Elevation of Wind	9	10	ft
Bottom Elevation of Wind	0	5	ft
Top Elevation of Water	0	5	ft
Bottom Elevation of Water	0	0	ft

**Hydrostatic Load**

Density of water	$\rho_w$	62.4	62.4	lb/ft <sup>3</sup>
Total load on BMP	$H_{LUN2}$	0.00	0.78	kip/ L.F per unit ft length of BMP
Acting at height	$H_{1UN2}$	0.00	11.67	ft from mudline elevation

**Wind Load**

Wind pressure	$q_{z3000}$	24.89	24.89	lb/ft <sup>2</sup> Refer Basis of Design report
Total load on BMP	$W_{LUN2}$	0.22	0.12	kip/ L.F per unit ft length of BMP
Acting at height	$H_{2UN2}$	14.5	17.5	ft from mudline elevation

Total Load on BMP		0.22	0.90	(Hydrostatic + Wind)
<b>Net Load on BMP</b>	$N_{LUN2}$	0.68		kip/L.F (Exterior - Interior)
Acting at height	$H_{r1UN2}$	11.8		ft from mudline elevation

**Load Govern Check**

Design case hydrostatic load governs  
 Extreme Water Level (Hydrostatic) load acting on one side of the BMP is greater than the calculated net load on BMP.



Client IPC and MIMC Job Number 11215702 Sheet \_\_\_\_\_  
 Project San Jacinto River Waste Pits Site Sheets By U.Lobato Date 05-09-2025  
 Subject BMP Design - Wind Load Evaluation Checked By S.Chilka Date 05-09-2025

**Mudline Elevation = -20ft**

**Wind Load - Extreme Case (EX)**

**Condition 1**

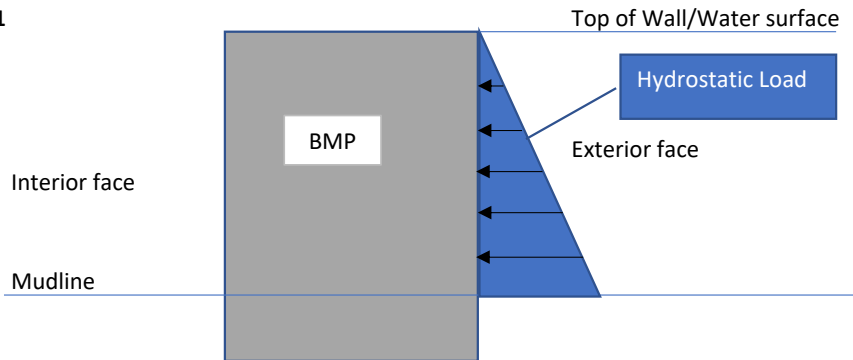

Wall	Interior	Exterior
Top of Wall elevation	9	10
Mudline elevation	-20	-20
Top Elevation of Wind	0	0
Bottom Elevation of Wind	0	0
Top Elevation of Water	0	10
Bottom Elevation of Water	0	0

**Hydrostatic Load**

Density of water	$\rho_w$	62.4	62.4	lb/ft <sup>3</sup>
Total load on BMP	$H_{1EX1}$	0.00	3.12	kip/ L.F per unit ft length of BMP
Acting at height	$H_{1EX1}$	0.00	23.33	ft from mudline elevation

**Wind Load**

Wind pressure	$q_{z3000}$	43.87	43.87	lb/ft <sup>2</sup> Refer Basis of Design report
Total load on BMP	$W_{LEX1}$	0.00	0.00	kip/ L.F per unit ft length of BMP
Acting at height	$H_{2EX1}$	0	0	ft from mudline elevation

Total Load on BMP		0.00	3.12	(Hydrostatic + Wind)
<b>Net Load on BMP</b>	$N_{LEX1}$	3.12		kip/L.F (Exterior - Interior)
Acting at height	$H_{nEX1}$	23.3		ft from mudline elevation

**Load Govern Check**

Design case hydrostatic load governs  
 Extreme Water Level (Hydrostatic) load acting on one side of the BMP is greater than the calculated net load on BMP.



Client IPC and MIMC Job Number 11215702 Sheet \_\_\_\_\_  
 Project San Jacinto River Waste Pits Site Sheets By U.Lobato Date 05-09-2025  
 Subject BMP Design - Wind Load Evaluation Checked By S.Chilka Date 05-09-2025

**Wind Load - Extreme Case (EX)**

**Condition 2**

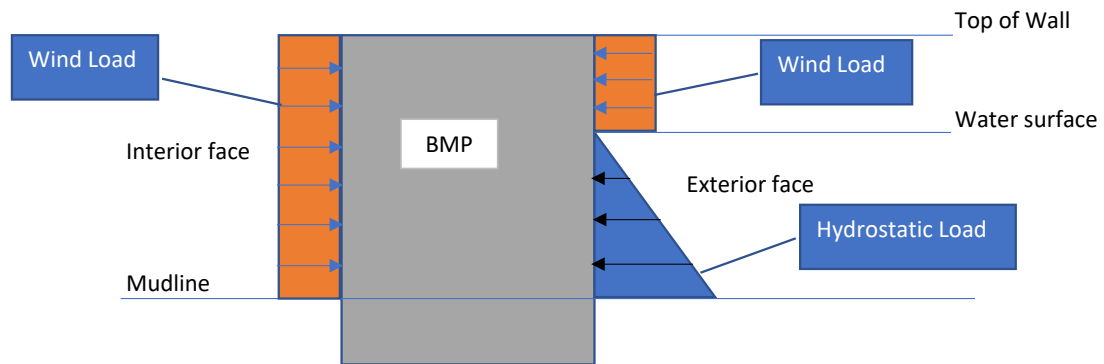

Wall	Interior	Exterior
Top of Wall elevation	9	10
Mudline elevation	-20	-20
Top Elevation of Wind	9	10
Bottom Elevation of Wind	0	5
Top Elevation of Water	0	5
Bottom Elevation of Water	0	0

**Hydrostatic Load**

Density of water	$\rho_w$	62.4	62.4	lb/ft <sup>3</sup>
Total load on BMP	$H_{LEX2}$	0.00	0.78	kip/ L.F per unit ft length of BMP
Acting at height	$H_{1EX2}$	0.00	21.67	ft from mudline elevation

**Wind Load**

Wind pressure	$q_{z3000}$	43.87	43.87	lb/ft <sup>2</sup> Refer Basis of Design report
Total load on BMP	$W_{LEX2}$	0.39	0.22	kip/ L.F per unit ft length of BMP
Acting at height	$H_{2EX2}$	24.5	27.5	ft from mudline elevation

Total Load on BMP		0.39	1.00	(Hydrostatic + Wind)
<b>Net Load on BMP</b>	$N_{LEX2}$	0.60		kip/L.F (Exterior - Interior)
Acting at height	$H_{nLEX2}$	21.9		ft from mudline elevation

**Load Govern Check**

Design case hydrostatic load governs  
 Extreme Water Level (Hydrostatic) load acting on one side of the BMP is greater than the calculated net load on BMP.



Client IPC and MIMC Job Number 11215702 Sheet \_\_\_\_\_  
 Project San Jacinto River Waste Pits Site Sheets By U.Lobato Date 05-09-2025  
 Subject BMP Design - Wind Load Evaluation Checked By S.Chilka Date 05-09-2025

**Wind Load - Unusual Case (UN)**

**Condition 1**

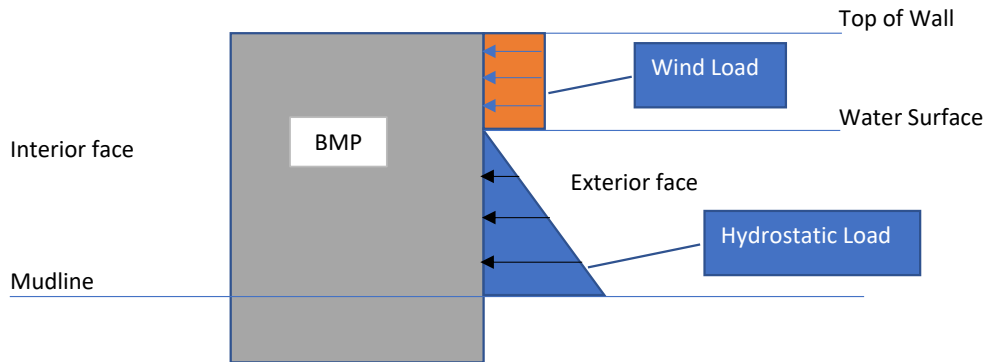

Wall	Interior	Exterior
Top of Wall elevation	9	10
Mudline elevation	-20	-20
Top Elevation of Wind	0	10
Bottom Elevation of Wind	0	5
Top Elevation of Water	0	5
Bottom Elevation of Water	0	0

**Hydrostatic Load**

Density of water	$\rho_w$	62.4	62.4	lb/ft <sup>3</sup>
Total load on BMP	$H_{LUN1}$	0.00	0.78	kip/ L.F per unit ft length of BMP
Acting at height	$H_{1UN1}$	0.00	21.67	ft from mudline elevation

**Wind Load**

Wind pressure	$q_{z3000}$	24.89	24.89	lb/ft <sup>2</sup> Refer Basis of Design report
Total load on BMP	$W_{LUN1}$	0.00	0.12	kip/ L.F per unit ft length of BMP
Acting at height	$H_{2UN1}$	0	27.5	ft from mudline elevation

Total Load on BMP		0.00	0.90	(Hydrostatic + Wind)
<b>Net Load on BMP</b>	$N_{LUN1}$	0.90		kip/L.F (Exterior - Interior)
Acting at height	$H_{r1UN1}$	22.5		ft from mudline elevation

**Load Govern Check**

Design case hydrostatic load governs  
 Extreme Water Level (Hydrostatic) load acting on one side of the BMP is greater than the calculated net load on BMP.



Client IPC and MIMC Job Number 11215702 Sheet \_\_\_\_\_  
 Project San Jacinto River Waste Pits Site Sheets By U.Lobato Date 05-09-2025  
 Subject BMP Design - Wind Load Evaluation Checked By S.Chilka Date 05-09-2025

**Wind Load - Unusual Case (UN)**

**Condition 2**

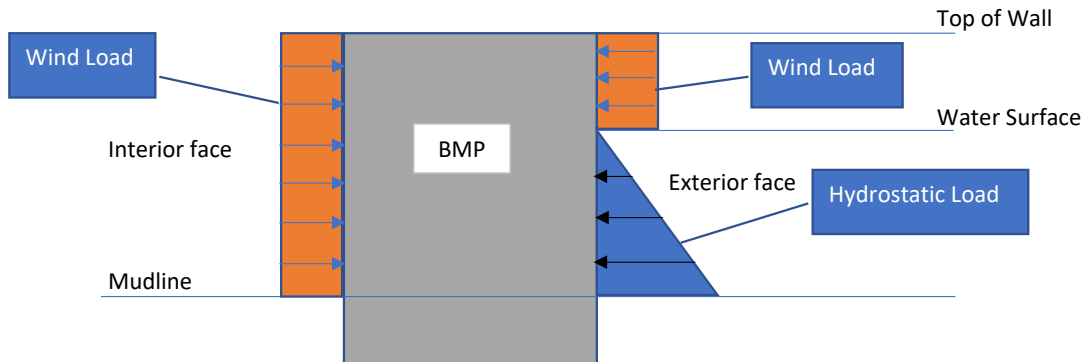

Wall	Interior	Exterior
Top of Wall elevation	9	10
Mudline elevation	-20	-20
Top Elevation of Wind	9	10
Bottom Elevation of Wind	0	5
Top Elevation of Water	0	5
Bottom Elevation of Water	0	0

**Hydrostatic Load**

Density of water	$\rho_w$	62.4	62.4	lb/ft <sup>3</sup>
Total load on BMP	$H_{LUN2}$	0.00	0.78	kip/ L.F per unit ft length of BMP
Acting at height	$H_{1UN2}$	0.00	21.67	ft from mudline elevation

**Wind Load**

Wind pressure	$q_{z3000}$	24.89	24.89	lb/ft <sup>2</sup> Refer Basis of Design report
Total load on BMP	$W_{LUN2}$	0.22	0.12	kip/ L.F per unit ft length of BMP
Acting at height	$H_{2UN2}$	24.5	27.5	ft from mudline elevation

Total Load on BMP		0.22	0.90	(Hydrostatic + Wind)
<b>Net Load on BMP</b>	$N_{LUN2}$	0.68		kip/L.F (Exterior - Interior)
Acting at height	$H_{rLUN2}$	21.8		ft from mudline elevation

**Load Govern Check**

Design case hydrostatic load governs  
 Extreme Water Level (Hydrostatic) load acting on one side of the BMP is greater than the calculated net load on BMP.



Client IPC and MIMC Job Number 11215702 Sheet \_\_\_\_\_  
Project San Jacinto River Waste Pits Site Sheets By S.Chilka Date 07-11-2024  
Subject BMP Design - Interlock Seepage Analysis Checked By \_\_\_\_\_ Date \_\_\_\_\_

APPENDIX I - BMP STRUCTURAL DESIGN REPORT  
**ATTACHMENT 3.5**  
**SHEET PILE SEEPAGE EVALUATION**



Client IPC and MIMC Job Number 11215702 Sheet \_\_\_\_\_  
 Project San Jacinto River Waste Pits Site Sheets By S.Chilka Date 07-11-2024  
 Subject BMP Design - Interlock Seepage Analysis Checked By \_\_\_\_\_ Date \_\_\_\_\_

Section	H (ft)	h (ft)	H (m)	h (m)	L (ft)	n
C1	19	22	5.8	6.7	370.0	161
C2, C5	24	20	7.3	6.1	910.0	396
C3, C3A	14	25	4.3	7.6	450.0	196
C4	22	18	6.7	5.5	310.0	135
C4A	17	27	5.2	8.2	650.0	283
C6, C7	9	35	2.7	10.7	950.0	414

H = Height of Water Column above Sediment  
 h = Thickness of Sediment Layers  
 L = Approximate length of each analysis sections  
 n = number of interlocks per lineal feet of BMP  
 Sheet Pile Width, b = 27.56 in, half pair  
 $n = L / b$

Arcelor Mittal, Impervious Steel Sheet Piles, Design & Practical Approach

Q1 = Discharge per interlock, cubic feet per second

Q = Total Discharge, cubic feet per second

$$Q1 = \rho H (0.5 H + h) \quad \text{m}^3/\text{s per interlock}$$

$$Q = n Q1 \quad \text{m}^3/\text{s, total}$$

$$Q = (22.83E6) n Q1 \quad \text{gal/day or GPD}$$

Inverse Resistivity ( $\rho$ ) of Interlocks for various seal conditions

Materials by Arcelor Mittal. Other comparable but proprietary products available.

Table 1					
Watertightening System	$\rho$ [ $10^{-10}$ m/s]			Application of the system	Cost ratio **
Hydrostatic pressure	100 kPa	200 kPa	300 kPa		
Empty interlock*	> 1000	-	-	-	0
Interlock with Beltan® Plus	< 600	-	-	easy	1.0
Interlock with Arcoseal™	< 600	-	-	easy	1.2
Interlock with ROXAN® Plus system	0.5	0.5	-	with care	1.8
Interlock with AKILA® system	0.3	0.3	0.5	with care	2.1
Welded interlock	0	0	0	after excavation for the interlock threaded on jobsite	5.0

\* Value available only at 150 kPa:  $\geq 4500$

Assume  $\rho$  = 1.00E-07 m/s, minimum inverse resistivity for standard interlocks

Use SF = 1.5 Safety factor for test parameters

$\rho$ , design = 1.50E-07

Section	Q1 (m3/s)	Q (GPD)
C1	8.3E-06	30676
C2, C5	1.1E-05	96815
C3, C3A	6.2E-06	27927
C4	8.9E-06	27398
C4A	8.4E-06	54341
C6, C7	5.0E-06	46785



Client IPC and MIMC Job Number 11215702 Sheet \_\_\_\_\_  
 Project San Jacinto River Waste Pits Site Sheets By S.Chilka Date 07-11-2024  
 Subject BMP Design - Interlock Seepage Analysis Checked By \_\_\_\_\_ Date \_\_\_\_\_

Assume  $\rho$  6.00E-08 m/s, maximum inverse resistivity for Beltan Plus or Arcoseal Seal  
 Use SF 1.5 Safety factor for test parameters  
 $\rho$ , design 9.00E-08

Section	Q1 (m3/s)	Q (GPD)
C1	5.00E-06	18406
C2, C5	6.42E-06	58089
C3, C3A	3.75E-06	16756
C4	5.33E-06	16439
C4A	5.05E-06	32605
C6, C7	2.97E-06	28071

Assume  $\rho$  5.00E-11 m/s, maximum inverse resistivity for ROXAN Plus System  
 Use SF 1.5 Safety factor for test parameters  
 $\rho$ , design 7.50E-11

Section	Q1 (m3/s)	Q (GPD)
C1	4.17E-09	15
C2, C5	5.35E-09	48
C3, C3A	3.12E-09	14
C4	4.45E-09	14
C4A	4.21E-09	27
C6, C7	2.48E-09	23

Assume  $\rho$  3.00E-11 m/s, maximum inverse resistivity for AKILA Seal  
 Use SF 1.5 Safety factor for test parameters  
 $\rho$ , design 4.50E-11

Section	Q1 (m3/s)	Q (GPD)
C1	2.50E-09	9
C2, C5	3.21E-09	29
C3, C3A	1.87E-09	8
C4	2.67E-09	8
C4A	2.52E-09	16
C6, C7	1.49E-09	14

**Summary:**

Any form of interlock sealant with partial to complete blockage capacity will significantly reduce any water inflow into the cofferdam. It is recommended that sealant be applied only to the inner walls of the BMP. This will allow drainage of water in the BMP fill material to drain toward the river and prevent contact with the material within the cofferdam.

ALTERNATIVE PRODUCT: WADIT, SEE DATASHEET ON NEXT PAGE



# Make Your Sheet Pile Watertight

**WADIT**

The Proven Sheet Pile Interlock Sealant

194367



## **WADIT® = Water Tight Corrosion Inhibitor**

WADIT is a purpose-built and globally proven sheet piling interlock sealant and corrosion inhibitor. The creators of WADIT know first-hand the installation and long-term challenges faced when sealing all types of hot rolled or cold formed sheet piling interlocks.

With an unmatched success rate in real-world applications, WADIT provides both water-stopping and corrosion protection. The application of WADIT in the WOF chamber minimizes corrosion by sealing the interlock. WADIT also acts as a pile lubricant by reducing friction and preventing interlocks from “heating up”; this allows for the contractor to choose to drive socket first, if needed.

For any application where water leakage presents a problem, from dewatering cofferdams to barrier and cutoff walls for site remediation, WADIT is the smart sheet pile sealant of choice.



## **Benefits**

### **TESTED AND CERTIFIED**

WADIT fortifies your project. This real-world and lab-tested sealant keeps water out and protects against hazardous substances. Comprehensive third party test data clearly states that the permeability of a sheet pile lock with WADIT is zero because there is NO water flow through the sheet pile lock at five bars (-70 psi) of differential water pressure. Please refer to the University of Dortmund Water-Tightness Study under the Technical Documents on [wadit.com](http://wadit.com).

### **HIGHLY DURABLE**

WADIT performs in every environment, from the tropics to the arctic, where high pressure sealing is required with extreme temperature ranges. The longevity of your sheet pile project is guaranteed with this durable sealant.

### **EXTREMELY FLEXIBLE**

WADIT has exceptional memory rebound properties. Conventional materials may harden like glass in temperatures of just 50F (10C). WADIT, on the other hand, remains extremely flexible even in groundwater.

### **NON-PROPRIETARY**

Made by and for sheet pile professionals, WADIT can be installed in any interlock system or used with U-, Z-, or O-type of walls or combined SSP.

### **ENVIRONMENTALLY FRIENDLY**

WADIT's non-toxic and made from sustainable, natural raw materials. Internationally lab-tested and certified, WADIT is safe and can be used without any restriction in sheet pile wall interlocks for ground and surface water use.

### **IMPERVIOUS TO WEATHER**

No matter the climate, WADIT can be applied, transported and stored in any weather condition, ensuring a fast and problem-free sealant application.

### **PROFESSIONALLY INSTALLED**

Certified technicians professionally install the WADIT Sealant System to ensure the perfect seal every time. You can be confident that the quality of your project will never be compromised.

# The Proven Sheet Pile Interlock Sealant

## WADIT: A Professionally Installed Sealant System

WADIT's unmatched success rate is the result of professional application. Applied by trained and tested WADIT installation crews, the WADIT Sealant System guarantees an effective, durable, sheet pile interlock seal every time. WADIT is sold pre-installed into any sheet pile type on a per foot or per metre of interlock basis.

Call PilePro at 866-666-7453 to find an authorized WADIT distributor in your area and/or to receive a quote for PilePro to carry out the WADIT installation.



## Internationally Lab-Tested and Certified

WADIT has been repeatedly proven as a safe material for use in potable water projects. The Bavaria State Trade Department (LGA), the German equivalent of the EPA, has certified WADIT for use in areas with potable water.



“The reports by the LGA come to the conclusion that WADIT sealant can be used without any restrictions in sheet pile wall interlocks in ground and surface water areas. There are no fears of harmful effects if it is used in the area of drinking water extraction systems.”

Read the full report at [WADIT.com](http://WADIT.com)

## WADIT Provides a Watertight and Long-Lasting Seal

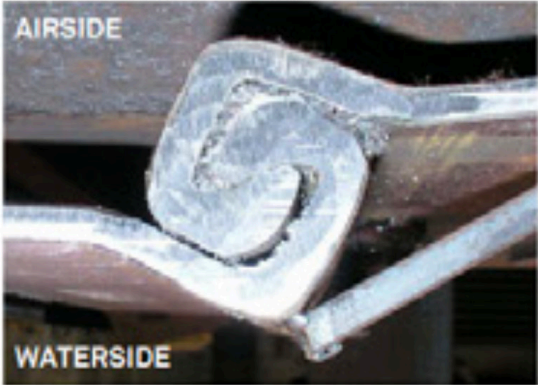

Larssen connectors

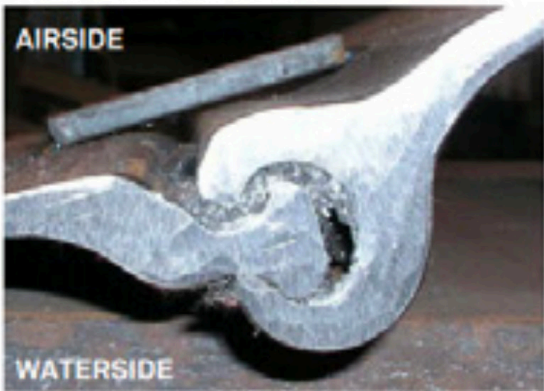

Ball and Socket Connectors

We have the right solutions for  
all of your sheet pile projects.

Contact us at  
866-666-7453 or 512-243-1228  
info@sheet-pile.com  
sheet-pile.com/wadit

**Sheet Pile** LLC

These brands and products are supplied exclusively by or through Sheet Pile LLC.

Toll free: 866.666.7453 | +1.512.243.1228 | info@sheet-pile.com



WADIT

O-Pile

I-Pile

I+Z Pile

O+Z Pile

Z-Pile



Client IPC and MIMC Job Number 11215702 Sheet \_\_\_\_\_  
 Project San Jacinto River Waste Pits Site Sheets By S.Chilka Date 07-16-2024  
 Subject BMP Design - Interlock Seepage Analysis Checked By \_\_\_\_\_ Date \_\_\_\_\_

**Calculating seepage from under the BMP walls**

The wall in the NW corner (Cross-Section C2) was selected for evaluating seepage / piping potential from under the wall. As the inner interlocks will be installed with a sealant, seepage across the BMP is considered negligible. See calculations for interlock seepage. Cross-Section C2 is exposed the largest head differential between the interior and exterior. Lane's Weighted Creep Ratio was utilized to measure head loss along the sheet piles to the tip and back into the excavation area.

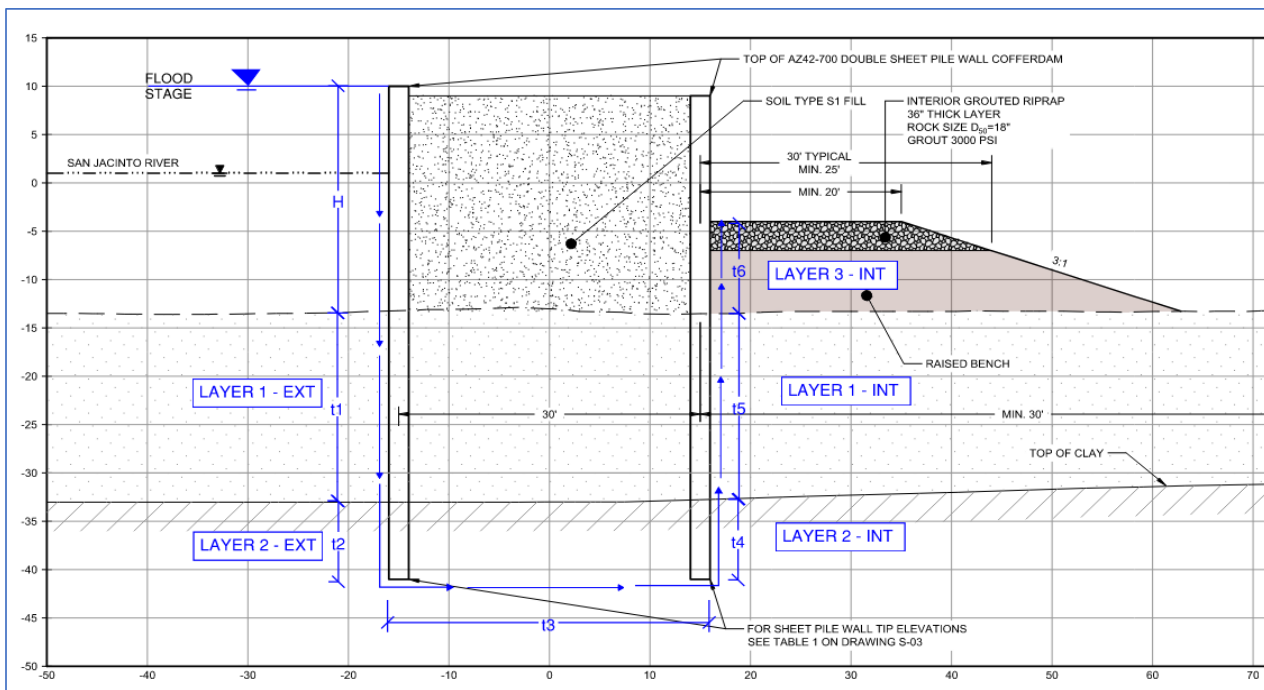

Safe Weighted Creep Ratio, Cr (Lane 1934)

Material	Cr	
Very Fine Silt or Sand	8.5	<< Alluvium Deposit (Layer 1)
Fine Sand	7	
Medium Sand	6	
Coarse Sand	5	
Fine Gravel	4	
Medium Gravel	3.5	<< Aggregate for Raised Bench (Layer 3)
Gravel and Sand	No value	
Boulders with some Cobbles and Gravel	2.5	
Boulders, Gravel, and Sand	No value	
Soft Clay	3	
Medium Clay	2	<< Beaumont Clay (Layer 3)
Hard Clay	1.8	
Very Hard Clay or Hardpan	1.6	



Client IPC and MIMC Job Number 11215702 Sheet \_\_\_\_\_  
 Project San Jacinto River Waste Pits Site Sheets By S.Chilka Date 07-16-2024  
 Subject BMP Design - Interlock Seepage Analysis Checked By \_\_\_\_\_ Date \_\_\_\_\_

Description	Elev (ft)
Top of Wall	10
Tip of Wall	-45
Mudline	-14

(See Drawing S-03)

Elev (ft)	Soil Layer 1	Soil Layer 2	Soil Layer 3
Top	-14	-33	-4
Bottom	-33	-45	-14

Total Head, H  ft << Available, Head Loss Required

Description	Distance (ft)	Cr	Head Loss (ft)
t1	19	8.5	2.2
t2	12	2	6.0
t3	10	2	5.0
t4	12	2	6.0
t5	19	8.5	2.2
t6	10	3.5	2.9
<b>Total Loss</b>			<b>24.3</b>
			<b>OKAY</b>

<< 1/3 x Distance between sheet pile walls

<< Head Loss under BMP

The calculation shows a higher head loss potential than the available head when the water is at the maximum elevation to top of wall.

Cr for the soil layer below mudline is conservatively assumed to be similar to "Very Fine Sand or Silt". For other soil types, as the Cr value decreases, the head loss along the wall increases.

In other locations along the BMP, the total head available will be lower due to shallow mudline. Therefore, the seepage / piping potential for water from the river into the excavation area is insignificant.



Client IPC and MIMC Job Number 11215702 Sheet \_\_\_\_\_  
Project San Jacinto River Waste Pits Site Sheets By S.Chilka Date 11-19-2024  
Subject BMP Design - Barge Impact Checked By \_\_\_\_\_ Date \_\_\_\_\_

APPENDIX I - BMP STRUCTURAL DESIGN REPORT  
**ATTACHMENT 3.6 - BARGE IMPACT**  
**REV 3: MAY 2025**



Client IPC and MIMC Job Number 11215702 Sheet \_\_\_\_\_  
Project San Jacinto River Waste Pits Site Sheets By S.Chilka Date 11-19-2024  
Subject BMP Design - Barge Impact Checked By \_\_\_\_\_ Date \_\_\_\_\_

## 1. Design Approach

An engineered cofferdam using a best management practice (BMP) will encircle the Northern Impoundment of the San Jacinto River Waste Pits Superfund (Site). The following calculations summarize the design of a sacrificial barrier wall system comprising of fiberglass reinforced polymer (FRP) composite piles as the primary measure to protect the BMP against potential barge impacts. The BMP structure itself is also evaluated for secondary impact after the barrier wall is damaged.

The Texas Department of Transportation (TxDOT)'s design criteria for the dolphin and fender system protecting the Interstate-10 (I-10) Bridge piers includes impact from a 30,000-barrel (bbl) barge, which represents one of the larger barges operating in the vicinity of the bridge. A typical 30,000-bbl barge is 300-ft long, 54-ft wide, and 12-ft tall. In a laden condition, loaded to full capacity, such a barge would displace the equivalent of 30,000-bbl or approximately 168,500-ft<sup>3</sup> of water. Thus, the barge is assumed to weigh approximately 5,250 U.S. tons or 10,500 kips in laden condition. In ballasted condition, the barge carries only fuel and ballast water and weighs approximately 910 U.S. tons or 1,820 kips.

The hydrodynamic model (Reference 1, Section 4) evaluated the flow velocities for various storm conditions and noted the maximum river flow velocity of 3.14-ft/s and 95<sup>th</sup> percentile velocity of 2.2-ft/s. The velocity data processed from the measurements taken by the buoys installed at Site determined maximum velocity of 5-ft/s but only 11 individual instances (10-minute each) out of the 129,593 observations showed velocity exceeding 4 ft/s. Therefore, using 4 ft/s to evaluate barge impact is considered appropriate.

The kinetic energy from impact can be determined from the weight and velocity of the barge at impact which may be either the river flow velocity or the navigation speed. The energy of impact will be lower for any impact angle other than a direct, head-on collision. The kinetic energy will be absorbed by the structures and the barge itself will absorb some energy and suffer damage. The energy absorbed due to damage to the barge is not considered in this evaluation as a conservative approach.

The standard design practice requires structures, such as bridge piers within the navigational waterway, to be designed for barge impacts. The Northern Impoundment is not within the navigational waterway so the BMP will not be routinely exposed to barges heading directly toward the structure. An impact could be the result of a barge coming off its mooring and drifting toward the BMP during a storm event or it could be the result of a towed barge veering off course or a barge losing control/power. Hence, considering head-on impact for purposes of the analysis is a conservative approach.

The equations available to calculate energy and force from barge impact were developed for design of bridge piers, which have a smaller profile than the BMP wall (without barrier wall) and absorb a large portion of the impact energy assuming minimal damage to the barge itself. The American Association of State Highway Transportation Officials (AASHTO) (Reference 2, Section 4) method to determine impact force absorbed by bridge piers was used for evaluating the BMP for direct impact. This method is conservative since the BMP and the barrier wall system will have a much larger profile area than the typical bridge piers to absorb impact and distribute the energy.

The impact energy from a barge moving at the river flow velocity will be absorbed in two stages:

1. Primary or first contact will be with the barrier wall system. The barrier wall is designed to absorb impact energy of 829- kip.ft corresponding to head-on impact from a laden barge at 2.2-ft/s or a ballasted barge at 5.3-ft/s.
2. As the barge damages the barrier wall and potentially breaks through, it will lose energy. The BMP may be subject to the remaining energy. In the 90% RD, the BMP was evaluated for maximum impact force of up to 1400-kips. This force corresponds to impact energy due to head-on impact from a laden barge at 2.2-ft/s or a ballasted barge at 5.3-ft/s.



Client IPC and MIMC Job Number 11215702 Sheet \_\_\_\_\_  
Project San Jacinto River Waste Pits Site Sheets By S.Chilka Date 11-19-2024  
Subject BMP Design - Barge Impact Checked By \_\_\_\_\_ Date \_\_\_\_\_

Using the AASHTO method, kinetic energy (KE) for barge impact as:

$$KE, \text{ laden barge} = \frac{C_H W V^2}{29.2} = 829\text{-kip.ft}$$

Where,

W = Displacement of the Barge (tonne = 1.1 US-tons) = 4773-tonne

V = Impact Velocity = 2.2-ft/s

C<sub>H</sub> = Hydrodynamic Mass Coefficient = 1.05

Total Impact Force on BMP = 1400-kips

$$KE, \text{ laden barge} = \frac{C_H W V^2}{29.2} = 425\text{-kip.ft}$$

Where,

W = Displacement of the Barge (tonne = 1.1 US-tons) = 4783-tonne

V = Impact Velocity = 1.6-ft/s

C<sub>H</sub> = Hydrodynamic Mass Coefficient = 1.05

Total Impact Force on BMP = 1000-kips

$$KE, \text{ ballasted barge} = \frac{C_H W V^2}{29.2} = 829\text{-kip.ft}$$

Where,

W = Displacement of the Barge (tonne = 1.1 US-tons) = 827-tonne

V = Impact Velocity = 5.3-ft/s

C<sub>H</sub> = Hydrodynamic Mass Coefficient = 1.05

Total Impact Force on BMP = 1400-kips

$$KE, \text{ ballasted barge} = \frac{C_H W V^2}{29.2} = 425\text{-kip.ft}$$

Where,

W = Displacement of the Barge (tonne = 1.1 US-tons) = 827-tonne

V = Impact Velocity = 3.8-ft/s

C<sub>H</sub> = Hydrodynamic Mass Coefficient = 1.05

Total Impact Force on BMP = 1000-kips



Client IPC and MIMC Job Number 11215702 Sheet \_\_\_\_\_  
Project San Jacinto River Waste Pits Site Sheets By S.Chilka Date 11-19-2024  
Subject BMP Design - Barge Impact Checked By \_\_\_\_\_ Date \_\_\_\_\_

The west side of the Northern Impoundment is not exposed to any barge traffic; therefore, a barrier wall in this area is not required. However, as the barges moored on the north side of the BMP may come off the moorings and float toward the Site, the BMP walls are evaluated for direct impact from ballasted barges.

## 2. FRP Barrier Wall

As an additional measure to provide increased protection from potential barge impacts, a barrier wall would be installed at approximately 20 to 25 ft from the exterior wall of the BMP. The barrier wall would be installed to the north and east side of areas exposed to potential impacts from loaded barges. The general alignment, typical section and elevation of the barrier wall are shown on Figure 2.1 through Figure 2.3.

The barrier wall will be comprised of 18-inch diameter FRP composite piles spaced at 8-ft on center. Four rows of 12-inch by 12-inch reinforced high-density polyethylene (HDPE) walers will be installed horizontally on the exterior side of the FRP piles, evenly spaced between Elevation +2 and +12 ft above mean water level (Figure 2.2 and Figure 2.3).

Similar to the BMP, the height of the FRP piles above riverbed and the variation in subsurface strata will affect the performance of the barrier wall. Hence, design parameters corresponding to various BMP cross-sections, such as Section C2, Section C3, Section C4, and Section C5 were considered to evaluate the energy absorption capacity of the barrier wall. Section C4 governs over Section C4A, due to relatively greater depth to riverbed.

The piles used in the analysis are a proprietary product manufactured by Creative Pultrusions, Inc. and marketed as Superpile. The walers are manufactured by Tangent Materials. However, other FRP pile or HDPE walers with equivalent properties can be used in construction. The allowable design values (i.e., moment capacity of the FRP piles and walers), as shown in the below Table 2.1, are determined through full-scale testing by the manufacturer. The barrier wall is designed as a sacrificial element (i.e., acceptable to undergo damage) to absorb the maximum amount of impact energy. Hence, no reduction factors are applied to the moment capacity.

Table 2.1 Moment Capacity of FRP Piles and Walers

Component	Moment Capacity (kip-ft)	
	ASTM D6109 Mean Test Results	ASTM D7290 Design Property
FRP Pile, 18-in x 0.75-in TU 465	750	591
Waler, 12-in x 12-in 8F12	283	N/A



Client IPC and MIMC Job Number 11215702 Sheet \_\_\_\_\_  
Project San Jacinto River Waste Pits Site Sheets By S.Chilka Date 11-19-2024  
Subject BMP Design - Barge Impact Checked By \_\_\_\_\_ Date \_\_\_\_\_

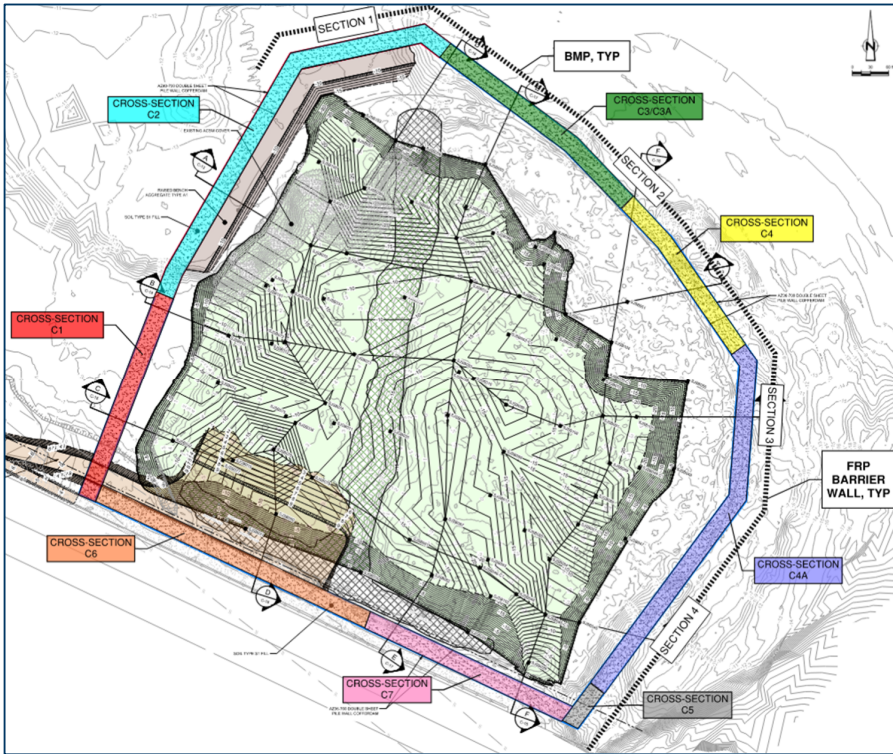

Figure 2.1 Alignment - FRP Barrier Wall

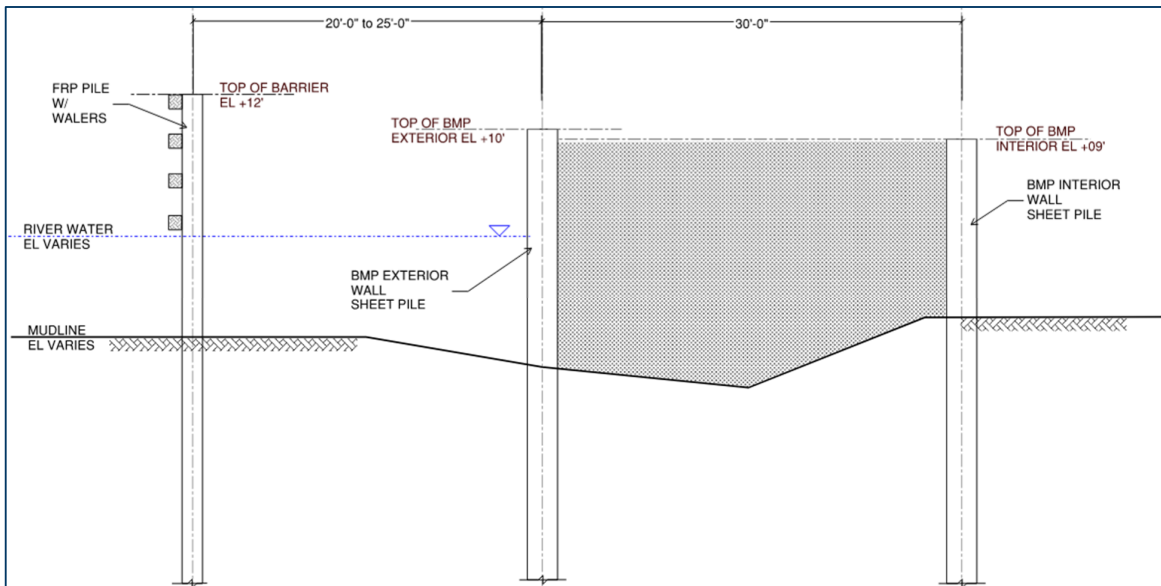

Figure 2.2 Typical Section - FRP Barrier Wall



Client IPC and MIMC Job Number 11215702 Sheet \_\_\_\_\_  
Project San Jacinto River Waste Pits Site Sheets By S.Chilka Date 11-19-2024  
Subject BMP Design - Barge Impact Checked By \_\_\_\_\_ Date \_\_\_\_\_

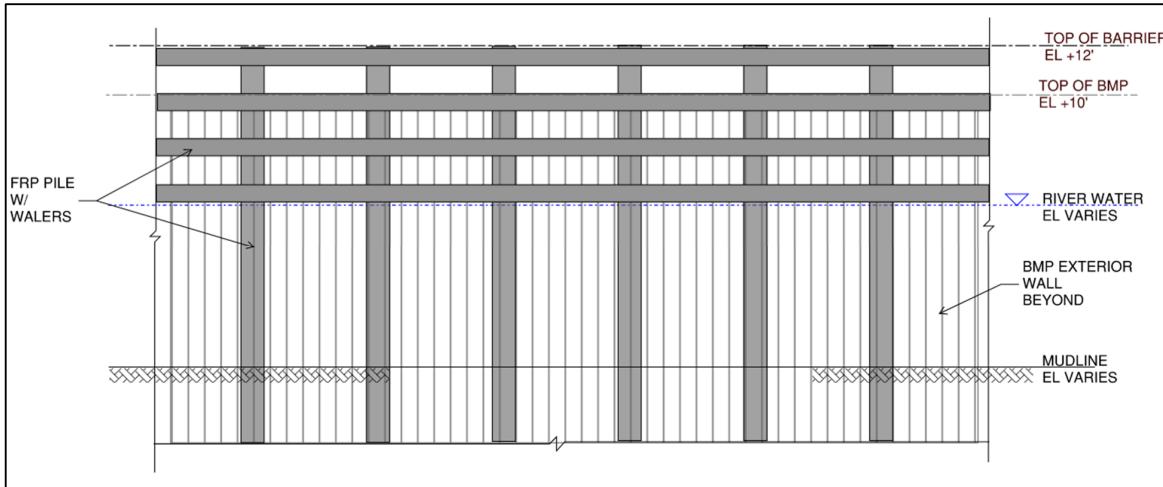

Figure 2.3 Typical Elevation - FRP Barrier Wall

The barge will contact the walers and in turn, multiple FRP piles are engaged, and the barrier wall system will deflect to absorb the impact energy. The largest moment demands on the pile sections are seen when the barge impact is at or near the top of the barrier wall. At lower elevations of impact, the moment demands are lower and do not govern the design. The results from the analysis with impact at top waler and lower waler are shown in the below Table 2.2 and Table 2.3 respectively. The system has capacity to absorb the kinetic energy from impact with a laden barge at 2.2 ft/s or ballasted barge at 5.3 ft/s.



Client IPC and MIMC Job Number 11215702 Sheet \_\_\_\_\_  
Project San Jacinto River Waste Pits Site Sheets By S.Chilka Date 11-19-2024  
Subject BMP Design - Barge Impact Checked By \_\_\_\_\_ Date \_\_\_\_\_

**Table 2.2** *Energy Absorption Capacity of FRP Barrier Wall – Impact at Top Water*

FRP Location	BMP Design Parameters	Energy Absorbed (kip-ft)	Pile Deflection (inches)	FRP Pile Length (ft)
Section 1	Section C2	950	147	61
Section 2	Section C3	885	110	53
Section 2	Section C4	895	125	56
Section 3	Section C4	927	126	56
Section 4	Section C4	927	126	56
Section 4	Section C5	939	146	60

**Table 2.3** *Energy Absorption Capacity of FRP Barrier Wall – Impact at Lower Water*

FRP Location	BMP Design Parameters	Energy Absorbed (kip-ft)	Pile Deflection (inches)	FRP Pile Length (ft)
Section 1	Section C2	863	138	61
Section 2	Section C3	869	109	53
Section 2	Section C4	886	121	56
Section 3	Section C4	897	123	56
Section 4	Section C4	845	118	56
Section 4	Section C5	864	137	60

Detailed calculations of the FRP barrier system are provided in the design report prepared by AXCESS. See next page.

**San Jacinto Fender System Design**

**Location – Texas**

**Prepared For:**



**Prepared By:**



**Andrew Loff, PE**

**[aloff@accessinfrastructure.com](mailto:aloff@accessinfrastructure.com)**

**Mark Watt, PE**

**[mwatt@accessinfrastructure.com](mailto:mwatt@accessinfrastructure.com)**

**John Harper**

**[jharper@accessinfrastructure.com](mailto:jharper@accessinfrastructure.com)**

**937-907-0069**

**Rev-B**

**July 2, 2024**

July 2, 2024

Satish Chilka  
GHD

Re: San Jacinto Fender System Design

Enclosed herewith are calculations for the San Jacinto fender system in Texas. This design was based on the design criteria detailed in “Structural Update: San Jacinto River Waste Pits Superfund Site” dated from October 21, 2022.

**Design Energy** – 829 kip-ft (AASHTO LRFD Bridge Design Specification, Ninth Edition, 2020)

**Deflection Limitation** – None Specified

**Fender System Length** – 1,879 ft

**Water Elevations** –

- MLW +2' (Provided by GHD)
- MHW +9' (Provided by GHD)

**Top of Fender System Wale** – EL +12' (Provided by GHD)

**Bottom of Fender System Wale** – EL +4'

**Design Mudline Elevation** – Varies based on soil profiles provided by GHD (2022-09-09 Soil Properties – FRP Dolphins)

**Soil Profile** – FB Multiplier Soil Inputs provided by GHD. Report on FB Multiplier inputs shown in appendix E.

**Principal Structural Materials of Construction** –

- 18" x ¾" Pile from Creative Composites Group
- 12x12-8F12 (12" x 12" w/8ea 1.5" FRP rebar in HDPE wale) from Tangent

The design assumptions detailed in this letter have been utilized in the design of the San Jacinto fender system.

## Contents

1 Executive Summary..... 3

2 Fender Layout Sketch..... 4

3 Analysis ..... 6

    3.1 Fender System Layout (Figure 3 - Figure 6) ..... 6

    3.2 Soil Properties ..... 8

    3.3 FB-Multiplier Pile/Wale Input Stress/Strain Curves..... 15

    3.4 Pile and Wale Properties..... 16

    3.5 Energy Analysis and Calculation..... 17

    3.6 Low Water Energy Analysis and Calculations ..... 49

4 Minimum Tip Analysis..... 79

    4.1 Tip Analysis by Boring Location..... 79

5 FRP Splice Plate Calculations..... 85

6 Material Maintenance ..... 87

Appendix A – Pile Technical Data Sheet ..... 88

Appendix B – Pile Test Report..... 105

Appendix C – SeaTimber Technical Data Sheet ..... 127

Appendix D – SeaTimber Field Installation and Maintenance Sheet..... 128

Appendix E – Soil Inputs for FB Multiplier ..... 134

### REVISION A CHANGES:

1. Properties updated to reflect the third party testing done on the 18” diameter x 3/4” wall thickness piles.
2. Additional analysis was added to evaluate a barge impact on only the lowest row of wales to simulate a low water impact event.
3. Splice plate calculations updated.

# 1 Executive Summary

Mark Watt, PE evaluated the composite fender system for the San Jacinto fender system using 18” diameter with 3/4” wall thickness piles manufactured by the Creative Composites Group in conjunction with the 12x12 8F12 SeaTimber Wales manufactured by Tangent.

The intent of this design is to provide a system that meets the energy absorption requirements specified and conforms to the geometric footprint laid out for this project. The fender system acts as a sacrificial protective barrier to prevent barge impacts to the steel sheet pile walls installed behind the system. The calculations in this report only show the sufficiency of the system to absorb design impact energy. However, the system will continue absorbing energy after the initial failure as the loads are distributed to additional piles and rows of wales.

These calculations show that the proposed system of 18” diameter piles in combination with 12x12-8F12 plastic lumber wales achieves the design requirement of 829 ft-kip of energy absorption while deflecting less than 12.25 ft (147 in). Table 1 below shows a summary of the results.

Table 1: Load Case and Results Summary

Load Case	Max Pile Deflection (in)	Absorbed Energy (ft-kip)
Section 1 - C2 Soil Load Case	146.9	950
Section 2 - C3 Soil Load Case	110.2	884.6
Section 2 - C4 Soil Load Case	124.5	895
Section 3 - C4 Soil Load Case	125.9	926.9
Section 4 - C4 Soil Load Case	125.9	926.9
Section 4 - C5 Soil Load Case	145.5	938.7
Low Water Section 1 - C2 Soil Load Case	137.9	950
Low Water Section 2 - C3 Soil Load Case	108.9	863.2
Low Water Section 2 - C4 Soil Load Case	121.2	868.8
Low Water Section 3 - C4 Soil Load Case	122.5	886.3
Low Water Section 4 - C4 Soil Load Case	118.2	842.5
Low Water Section 4 - C5 Soil Load Case	136.7	863.7

A non-linear analysis utilizing FB-Multiplier (BSI) software was used to calculate the energy capacity, maximum moments in the piles and wales, as well as the system deflection. The load cases that were evaluated were based on barge dimensions and angle of impact provided by GHD.

Minimum tip analysis was also run, which details the minimum tip elevation for this fender system.

## 2 Fender Layout Sketch

Fender system length is assumed to be 1,879 ft. System will be broken into 4 sections as shown in Figure 1. Wale sections are to be delivered in 64' or 72' sections and to be spliced together between pile spacings. Each transition between sections will be spliced with FRP plates with a pile installed at either end of the splice plate. Figure 2 shows a sketch of the typical elevation view of the fender system at a pile location.

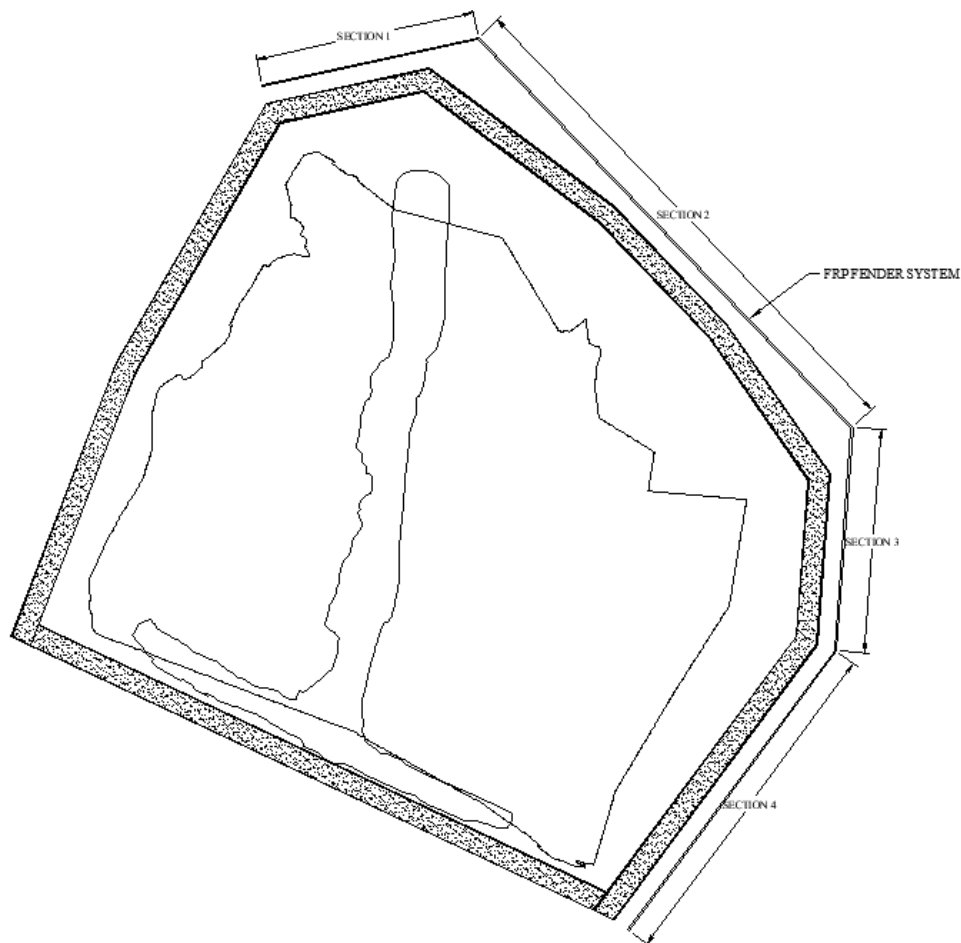

Figure 1: Fender Elevation

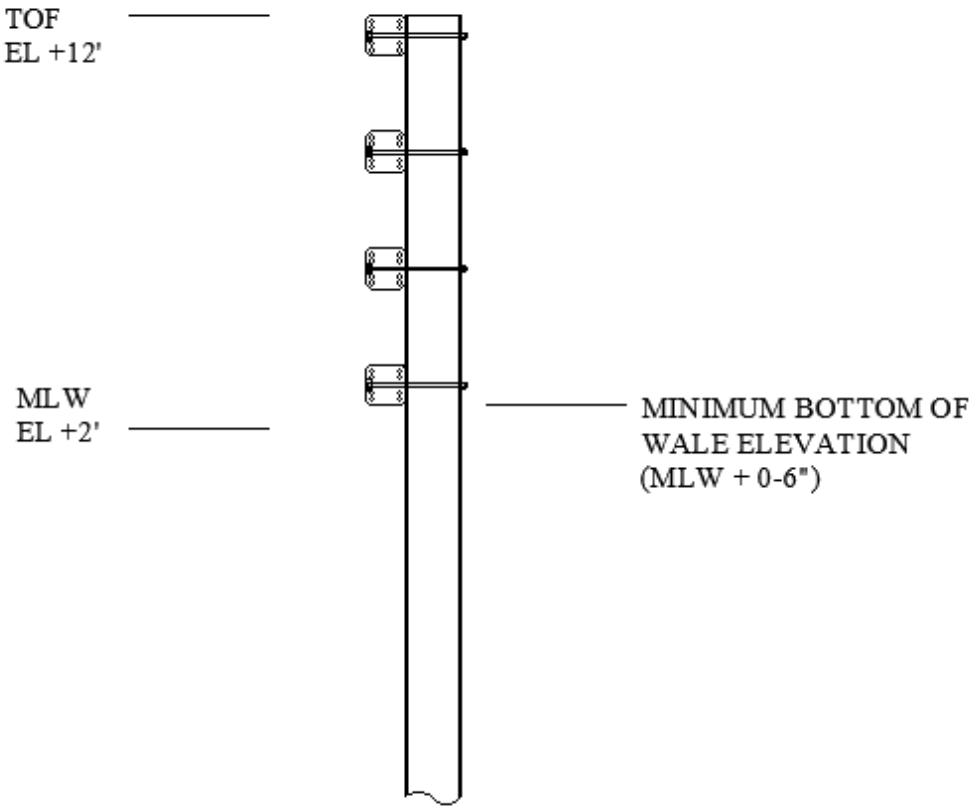

Figure 2: Fender Elevation

### 3 Analysis

#### 3.1 Fender System Layout (Figure 3 - Figure 6)

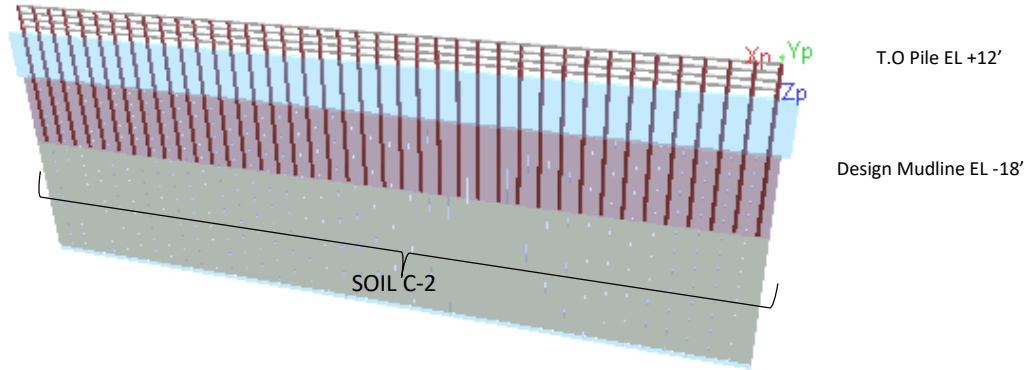

Figure 3: Section 1 Fender System - Soil Profile C2

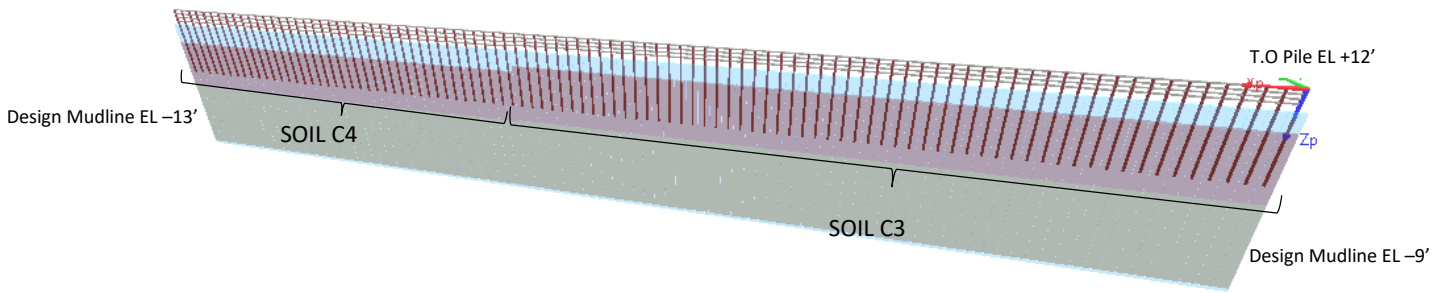

Figure 4: Section 2 Fender Layout - Soil Profile C3 & C4

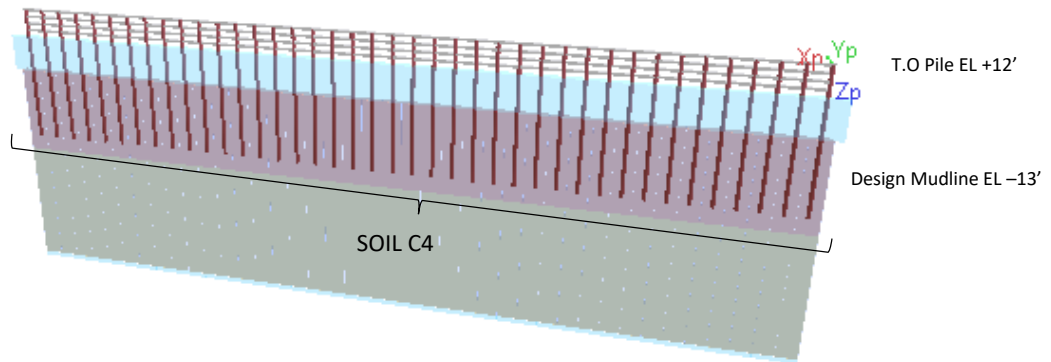

Figure 5: Section 3 Fender Layout - Soil Profile C4

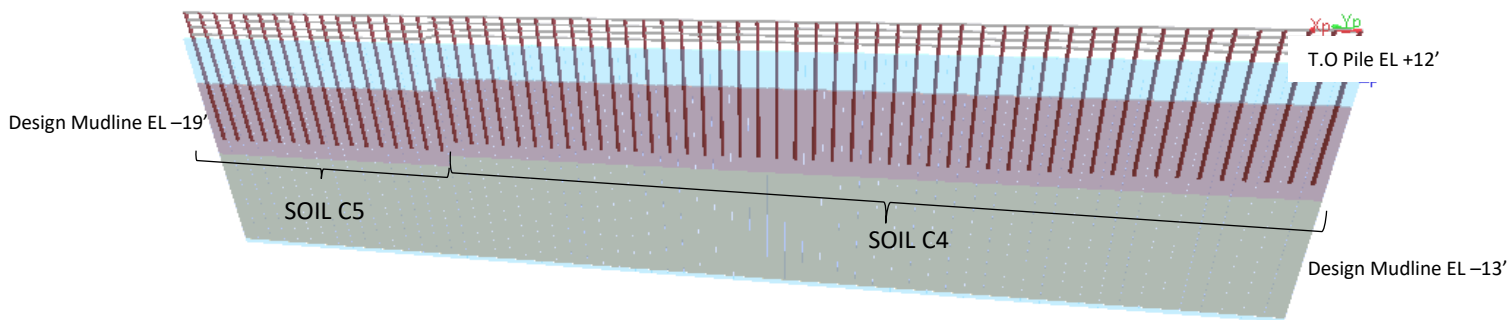

Figure 6: Section 4 Fender Layout –Soil Profile C4 & C5

- Pile and Wale spacings in FB-Multipier model are per the drawing layout.
- Piles are 18" diameter x 3/4" wall piles from the Creative Composites Group.
- Wales are four rows of 12x12 8F12 SeaTimber Wales from Tangent.

### 3.2 Soil Properties

Figure 7 - Figure 30 below summarize the parameters for the soil layers added to the FB-Multiplier model for the Fender System. The soil profiles were created from the soil parameters given by GHD and shown in Appendix F. Based on the soil profile provided, there are four separate profiles for the fender system.

#### 3.2.1 C2 Soil Properties

Soil Layer Table

Soil Set	Soil Layer	Soil Type	Top	Bottom	Lateral Model	Axial Model	Torsional Model	Tip Model	Unit	Unit	Specify
			Layer	Layer					Elevation	Elevation	(Top)
			(ft)	(ft)					(pcf)	(pcf)	Properties
2	1	Cohesive	-18.00	-36.00	Clay (O'Neill)	Driven Pile (McVay)	Hyperbolic	Driven Pile (McVay)	100.000	119.000	<input checked="" type="checkbox"/>
2	2	Cohesive	-36.00	-48.00	Clay (O'Neill)	Driven Pile (McVay)	Hyperbolic	Driven Pile (McVay)	130.000	140.000	<input checked="" type="checkbox"/>
2	3	Cohesionless	-48.00	-100.00	Sand (Reese)	Driven Pile (McVay)	Hyperbolic	Driven Pile (McVay)	112.000		<input type="checkbox"/>

Figure 7: Global Soil Elevations – C2

Lateral Model Table

Soil Set	Soil Layer	Lateral Model	Internal	Subgrade	Mass	Stiffness	Undrained	Major	Major
			Friction						
			(deg)	(lb/in^3)	(ksi)	krm	(psf)	@50%	@100%
2	1 (top)	Clay (O'Neill)					200.0000	0.0200	0.0600
2	1 (bottom)	Clay (O'Neill)					324.0000	0.0200	0.0600
2	2 (top)	Clay (O'Neill)					3288.0000	0.0050	0.0150
2	2 (bottom)	Clay (O'Neill)					4392.0000	0.0050	0.0150
2	3	Sand (Reese)	37.0000	110.0000					

Figure 8: Lateral Soil Properties – C2

Axial Model Table

Soil Set	Soil Layer	Axial Model	Internal	Poisson's	Undrained	Unconfined	Mass	Modulus	Modulus	Split	Shaft	Nominal	
			Friction										Shear
			(deg)	Ratio	(psf)	(psf)	(ksi)	(Em)	Ratio	Strength	Weight	Slump	Friction
								(Em/Ei)	Surface	(psf)	(pcf)	(in)	(psf)
2	1 (top)	Driven Pile (McVay)		0.15	0.40								200.00
2	1 (bottom)	Driven Pile (McVay)		0.62	0.40								200.00
2	2 (top)	Driven Pile (McVay)		4.63	0.50								1300.00
2	2 (bottom)	Driven Pile (McVay)		4.63	0.50								1300.00
2	3	Driven Pile (McVay)		2.45	0.30								1152.00

Figure 9: Axial Soil Properties – C2

Torsional Model Table

Soil Set	Soil Layer	Torsional Model	Shear	Torsional	Shear
			Modulus		
			(ksi)		(psf)
2	1 (top)	Hyperbolic	0.15		200.00
2	1 (bottom)	Hyperbolic	0.62		200.00
2	2 (top)	Hyperbolic	4.63		1300.00
2	2 (bottom)	Hyperbolic	4.63		1300.00
2	3	Hyperbolic	2.45		1152.00

Figure 10: Torsional Soil Properties – C2

Tip Model Table					
Soil	Tip	Internal Friction Angle (deg)	Shear Modulus (ksi)	Poisson's Ratio	Nominal Tip Resistance (kips)
Set	Model				
2	Driven Pile (McVay)		4.6300	0.5000	640.0000

Figure 11: Tip Soil Properties – C2

Soil Set 2 | Pile 1 | Pile Type 1

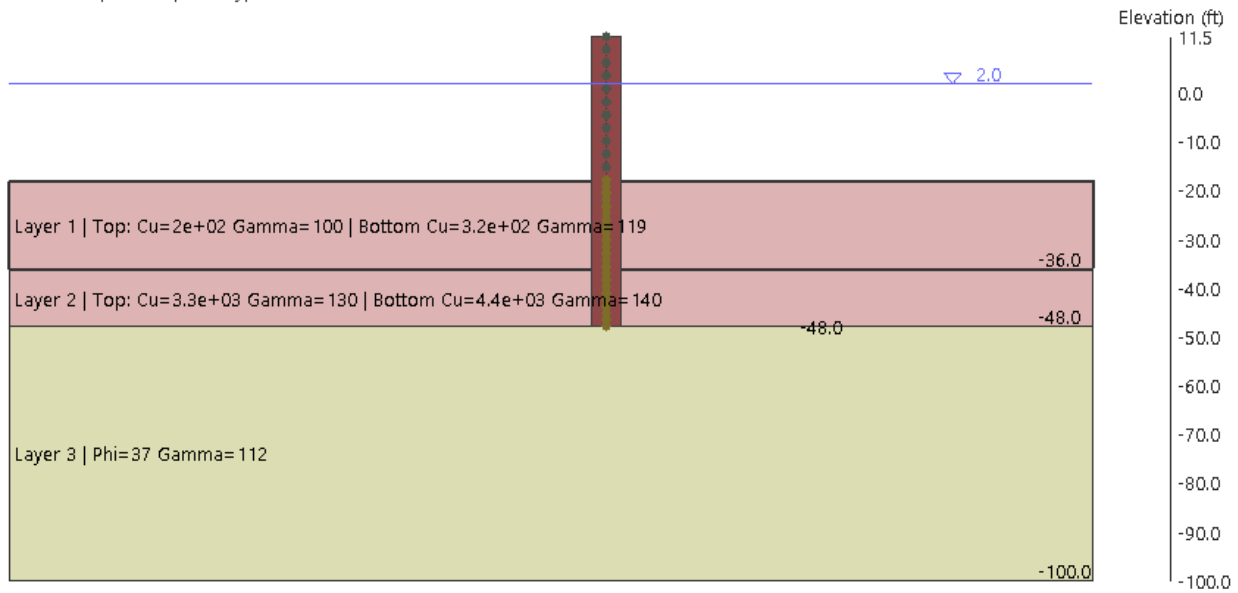

Figure 12: 18" Pile Soil Cross Section – C2 SOIL

### 3.2.2 C3 Soil Properties

Soil Layer Table													
Soil Set	Soil Layer	Soil Type	Top Elevation (ft)	Bottom Elevation (ft)	Lateral Model	Axial Model	Torsional Model	Tip Model	Unit Weight (Top) (pcf)	Unit Weight (Bottom) (pcf)	Specify Top & Bottom Properties	Del	La
1	1	Cohesive	-9.00	-29.00	Clay (O'Neill)	Driven Pile (McVay)	Hyperbolic	Driven Pile (McVay)	100.000	119.000	<input checked="" type="checkbox"/>	<input checked="" type="checkbox"/>	
1	2	Cohesive	-29.00	-48.00	Clay (O'Neill)	Driven Pile (McVay)	Hyperbolic	Driven Pile (McVay)	130.000	140.000	<input checked="" type="checkbox"/>	<input checked="" type="checkbox"/>	
1	3	Cohesionless	-48.00	-100.00	Sand (Reese)	Driven Pile (McVay)	Hyperbolic	Driven Pile (McVay)	112.000		<input type="checkbox"/>	<input type="checkbox"/>	

Figure 13: Global Soil Elevations – C3

Lateral Model Table														
Soil Set	Soil Layer	Lateral Model	Internal Friction Angle (deg)	Subgrade Modulus (lb/in <sup>3</sup> )	Mass Modulus (ksi)	Stiffness Constant (krm)	Undrained Shear Strength (psf)	Major Principal Strain @50%	Major Principal Strain @100%	Average Undrained Shear Strength (psf)	Unconfined Compressive Strength (psf)	RQD (%)	Poisson's Ratio	Residual Strength (psi)
1	1 (top)	Clay (O'Neill)					200.0000	0.0200	0.0600					
1	1 (bottom)	Clay (O'Neill)					486.0000	0.0200	0.0600					
1	2 (top)	Clay (O'Neill)					2644.0000	0.0050	0.0150					
1	2 (bottom)	Clay (O'Neill)					4392.0000	0.0050	0.0150					
1	3	Sand (Reese)	37.0000	110.0000										

Figure 14: Lateral Soil Properties – C3

Soil		Internal		Undrained		Unconfined		Mass		Shaft		Nominal	
Set	Layer	Angle	Friction	Modulus	Poisson's	Shear	Compressive	Modulus	Modulus	Split	Concrete	Unit	Coefficient
		(deg)	(ksi)	(ksi)	Ratio	(psf)	(psf)	(Em)	Ratio	Tensile	Unit	Slump	of Lateral
								(Em/Ei)	Surface	Strength	Weight	(in)	Earth
										(psf)	(pcf)		Pressure
1	1 (top)	Driven Pile (McVay)		0.15	0.40								200.00
1	1 (bottom)	Driven Pile (McVay)		0.62	0.40								200.00
1	2 (top)	Driven Pile (McVay)		4.63	0.50								1300.00
1	2 (bottom)	Driven Pile (McVay)		4.63	0.50								1300.00
1	3	Driven Pile (McVay)		2.45	0.30								1152.00

Figure 15: Axial Soil Properties – C3

Soil		Torsional		Shear		Torsional	
Set	Layer	Model	Modulus	Modulus	Stress	Stress	Plot
			(ksi)	(ksi)	(psf)	(psf)	
1	1 (top)	Hyperbolic		0.15		200.00	Plot
1	1 (bottom)	Hyperbolic		0.62		200.00	Plot
1	2 (top)	Hyperbolic		4.63		1300.00	Plot
1	2 (bottom)	Hyperbolic		4.63		1300.00	Plot
1	3	Hyperbolic		2.45		1152.00	Plot

Figure 16: Torsional Soil Properties – C3

Soil		Internal		Nominal	
Set	Tip	Angle	Modulus	Poisson's	Resistance
	Model	(deg)	(ksi)	Ratio	(kips)
1	Driven Pile (McVay)		4.63	0.5000	640.0000

Figure 17: Pile Tip Properties – C3

Soil Set 1 | Pile 56 | Pile Type 1

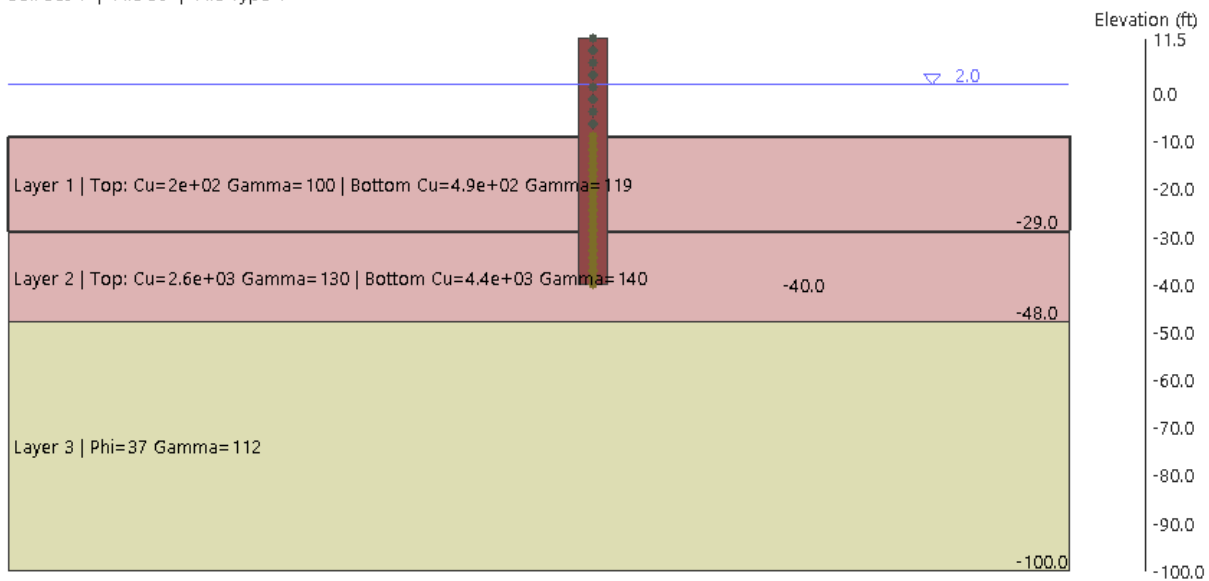

Figure 18: 18" Pile Soil Cross Section – C3 Soil

### 3.2.3 C4 Soil Properties

Soil Layer Table

Soil Set	Soil Layer	Soil Type	Top Layer Elevation (ft)	Bottom Layer Elevation (ft)	Lateral Model	Axial Model	Torsional Model	Tip Model	Unit Weight (Top) (pcf)	Unit Weight (Bottom) (pcf)	Specify Top & Bottom Properties
3	1	Cohesive	-13.00	-33.00	Clay (O'Neill)	Driven Pile (McVay)	Hyperbolic	Driven Pile (McVay)	100.000	119.000	<input checked="" type="checkbox"/>
3	2	Cohesive	-33.00	-49.00	Clay (O'Neill)	Driven Pile (McVay)	Hyperbolic	Driven Pile (McVay)	130.000	140.000	<input checked="" type="checkbox"/>
3	3	Cohesionless	-49.00	-100.00	Sand (Reese)	Driven Pile (McVay)	Hyperbolic	Driven Pile (McVay)	112.000		<input type="checkbox"/>

Figure 19: Global Soil Elevations – C4

Lateral Model Table

Soil Set	Soil Layer	Lateral Model	Internal Friction Angle (deg)	Subgrade Modulus (lb/in <sup>3</sup> )	Mass Modulus (ksi)	Stiffness Constant (krm)	Undrained Shear Strength (psf)	Major Principal Strain @50%	Major Principal Strain @100%
3	1 (top)	Clay (O'Neill)					200.0000	0.0200	0.0600
3	1 (bottom)	Clay (O'Neill)					488.0000	0.0200	0.0600
3	2 (top)	Clay (O'Neill)					3012.0000	0.0050	0.0150
3	2 (bottom)	Clay (O'Neill)					4840.0000	0.0050	0.0150
3	3	Sand (Reese)	37.0000	110.0000					

Figure 20: Lateral Soil Properties – C4

Axial Model Table

Soil Set	Soil Layer	Axial Model	Internal Friction Angle (deg)	Shear Modulus (ksi)	Poisson's Ratio	Undrained Shear Strength (psf)	Unconfined Compressive Strength (psf)	Mass Modulus (ksi)	Modulus Ratio (Em/Ei)	Split Tensile Strength (psf)	Shaft Concrete Weight (pcf)	Nominal Unit Skin Friction (psf)
3	1 (top)	Driven Pile (McVay)		0.15	0.40							200.00
3	1 (bottom)	Driven Pile (McVay)		0.62	0.40							200.00
3	2 (top)	Driven Pile (McVay)		4.63	0.50							1300.00
3	2 (bottom)	Driven Pile (McVay)		4.63	0.50							1300.00
3	3	Driven Pile (McVay)		2.45	0.30							1152.00

Figure 21: Axial Soil Properties – C4

Torsional Model Table

Soil Set	Soil Layer	Torsional Model	Shear Modulus (ksi)	Torsional Shear Stress (psf)	Nominal Tip Resistance (kips)
3	1 (top)	Hyperbolic	0.15		200.00
3	1 (bottom)	Hyperbolic	0.62		200.00
3	2 (top)	Hyperbolic	4.63		1300.00
3	2 (bottom)	Hyperbolic	4.63		1300.00
3	3	Hyperbolic	2.45		1152.00

Figure 22: Torsional Soil Properties – C4

Tip Model Table

Soil Set	Tip Model	Internal Friction Angle (deg)	Shear Modulus (ksi)	Poisson's Ratio	Nominal Tip Resistance (kips)
3	Driven Pile (McVay)		4.6300	0.5000	640.0000

Figure 23: Tip Soil Properties – C4

Soil Set 3 | Pile 57 | Pile Type 2

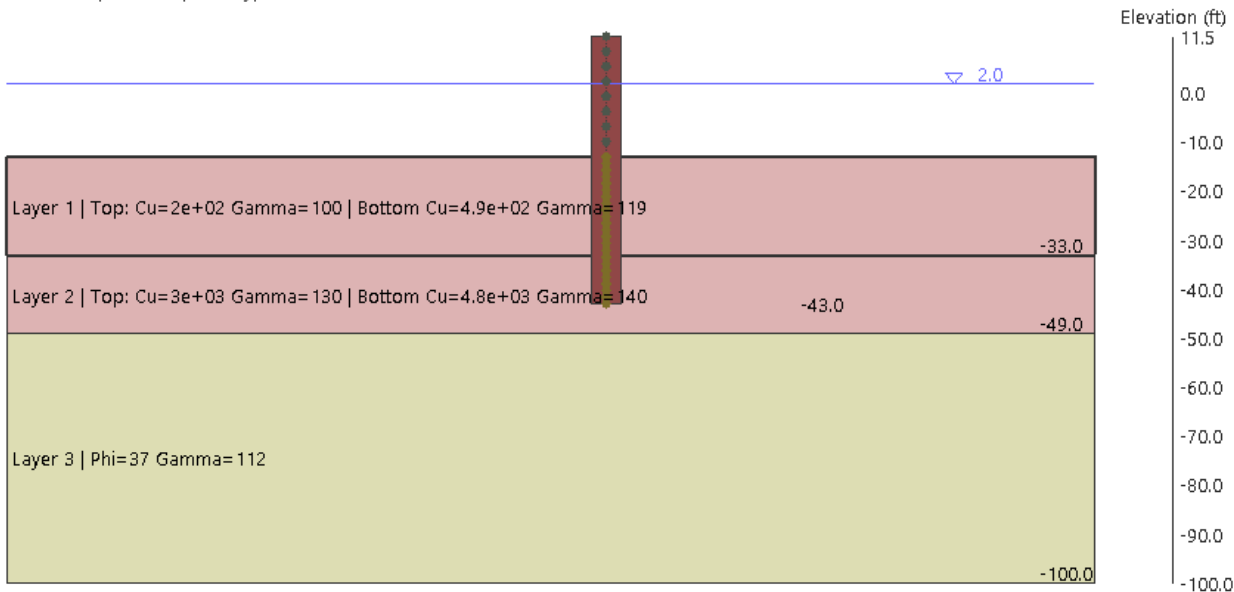

Figure 24: 18" Pile Soil Cross Section – C4 Soil

### 3.2.4 C5 Soil Properties

Soil Layer Table

Soil Set	Soil Layer	Soil Type	Top Layer Elevation (ft)	Bottom Layer Elevation (ft)	Lateral Model	Axial Model	Torsional Model	Tip Model	Unit Weight (Top) (pcf)	Unit Weight (Bottom) (pcf)	Specify Top & Bottom Properties
4	1	Cohesive	-19.00	-36.00	Clay (O'Neill)	Driven Pile (McVay)	Hyperbolic	Driven Pile (McVay)	100.000	119.000	<input checked="" type="checkbox"/>
4	2	Cohesive	-36.00	-54.00	Clay (O'Neill)	Driven Pile (McVay)	Hyperbolic	Driven Pile (McVay)	130.000	140.000	<input checked="" type="checkbox"/>
4	3	Cohesionless	-54.00	-100.00	Sand (Reese)	Driven Pile (McVay)	Hyperbolic	Driven Pile (McVay)	112.000		<input type="checkbox"/>

Figure 25: Global Soil Elevations – C5

Lateral Model Table

Soil Set	Soil Layer	Lateral Model	Internal Friction Angle (deg)	Subgrade Modulus (lb/in <sup>3</sup> )	Mass Modulus (ksi)	Stiffness Constant (krm)	Undrained Shear Strength (psf)	Major Principal Strain @50%	Major Principal Strain @100%
4	1 (top)	Clay (O'Neill)					200.0000	0.0200	0.0600
4	1 (bottom)	Clay (O'Neill)					458.0000	0.0200	0.0600
4	2 (top)	Clay (O'Neill)					3288.0000	0.0050	0.0150
4	2 (bottom)	Clay (O'Neill)					4944.0000	0.0050	0.0150
4	3	Sand (Reese)	37.0000	110.0000					

Figure 26: Lateral Soil Properties – C5

Axial Model Table

Soil Set	Soil Layer	Axial Model	Internal Friction Angle (deg)	Shear Modulus (ksi)	Poisson's Ratio	Undrained Shear Strength (psf)	Unconfined Compressive Strength (psf)	Mass Modulus (ksi)	Modulus Ratio (Em/EI)	Split Tensile Strength (psf)	Shaft Concrete Unit Weight (pcf)	Nominal Slump (in)	Nominal Friction (psf)
4	1 (top)	Driven Pile (McVay)		0.15	0.40								200.00
4	1 (bottom)	Driven Pile (McVay)		0.62	0.40								200.00
4	2 (top)	Driven Pile (McVay)		4.63	0.50								1300.00
4	2 (bottom)	Driven Pile (McVay)		4.63	0.50								1300.00
4	3	Driven Pile (McVay)		2.45	0.30								1152.00

Figure 27: Axial Soil Properties – C5

Torsional Model Table

Soil Set	Soil Layer	Torsional Model	Shear Modulus (ksi)	Torsional Shear Stress (psf)
4	1 (top)	Hyperbolic	0.15	200.00
4	1 (bottom)	Hyperbolic	0.62	200.00
4	2 (top)	Hyperbolic	4.63	1300.00
4	2 (bottom)	Hyperbolic	4.63	1300.00
4	3	Hyperbolic	2.45	1152.00

Figure 28: Torsional Soil Properties – C5

Tip Model Table

Soil Set	Tip Model	Internal Friction Angle (deg)	Shear Modulus (ksi)	Poisson's Ratio	Nominal Tip Resistance (kips)
4	Driven Pile (McVay)		4.6300	0.5000	640.0000

Figure 29: Tip Soil Properties – C5

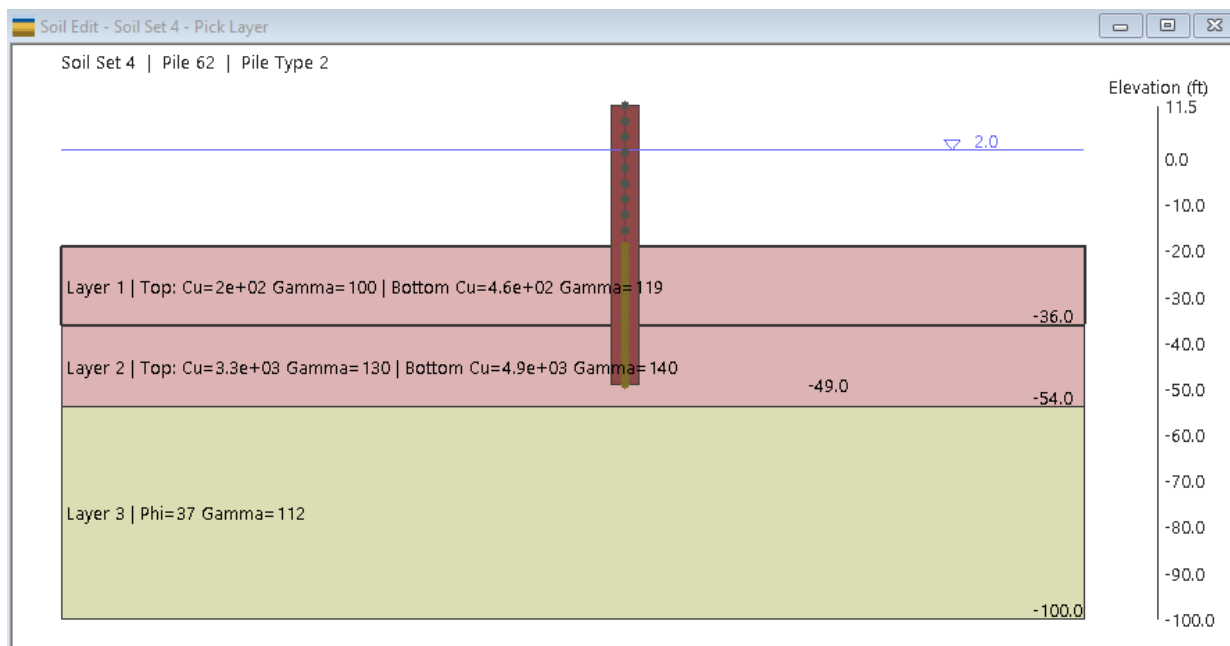

Figure 30: 18" Pile Soil Cross Section – C5 Soil

### 3.3 FB-Multiplier Pile/Wale Input Stress/Strain Curves

See Figure 31 and Figure 32 for the stress and strain inputs used to generate the Pile and Wale stress/strain curves, respectively.

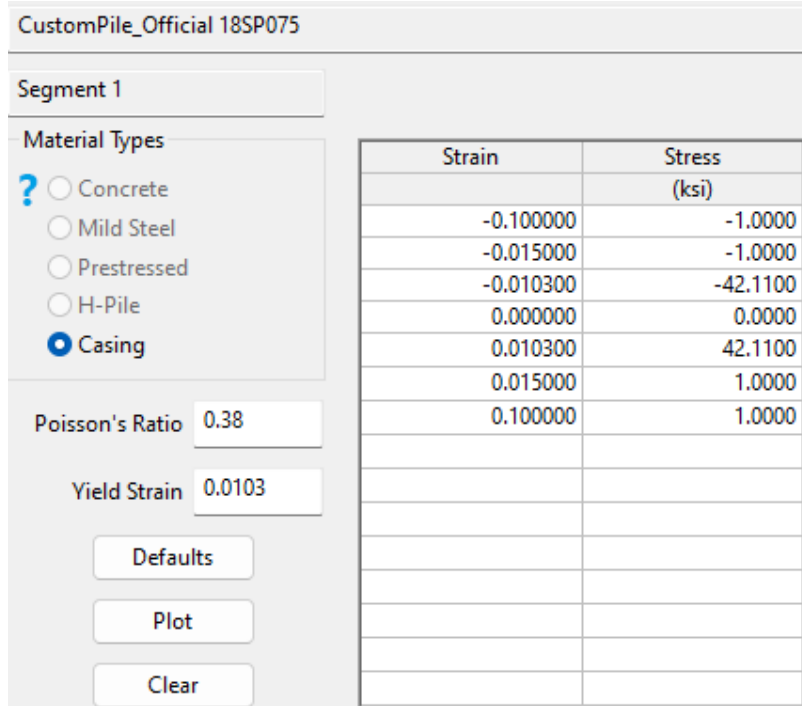

Figure 31: 18" OD x 0.75" WT Pile Properties

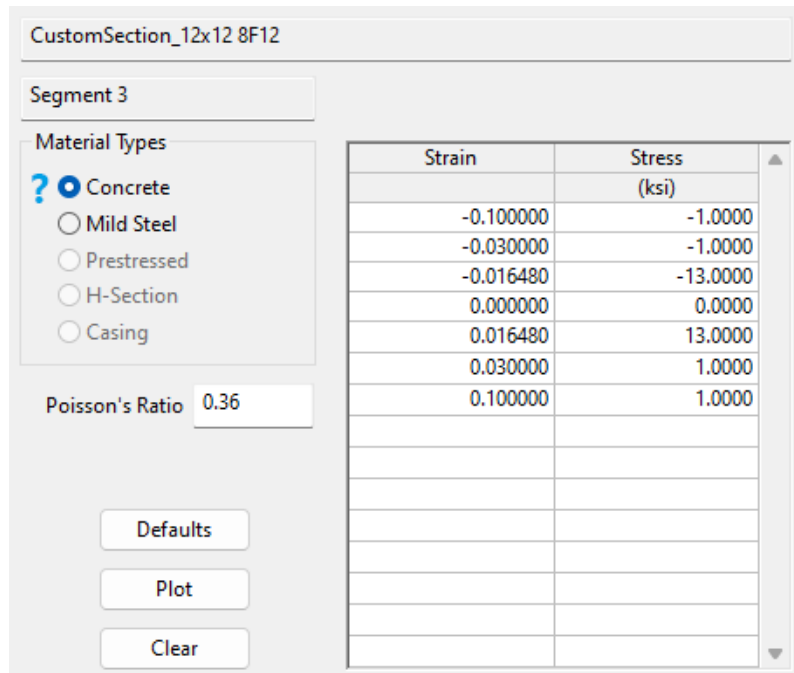

Figure 32: 12x12 8F12 Wale Properties

### 3.4 Pile and Wale Properties

The allowable design values for the piles and wales used in the fender system design were determined through full scale testing and the application of appropriate reduction factors. The processes used to determine the design values for each component type are provided below and the resulting moment capacities are shown in Table 2.

Since this fender system is a temporary protection system and is designed to be damaged to absorb the maximum amount of energy, there are no knockdowns applied to the moment capacity used in the design.

#### Piles:

- Test full-scale piles to ASTM D6109 with a minimum of 10 specimens.
- Conduct ASTM D7290 compliant statistical reductions to find allowable capacity.

#### Wales:

- Test full-scale wales to ASTM D6109 with a minimum of 5 specimens.

*Table 2: Allowable Moment Capacity for 18" x 3/4" Piles and SeaTimber Wales*

Component Type	ASTM D6109 Mean Test Results (kip-ft)	ASTM D7290 Design Property (kip-ft)
Pile - 18" x 0.75"	750	591
Wale - 12x12 8F12	283	N/A

### 3.5 Energy Analysis and Calculation

The fender system was analyzed in FB Multiplier using a non-linear analysis to determine the energy absorption, maximum moments, and deflections for each load case. Each section of the fender system was analyzed separately to determine the sufficiency to absorb the required 829 kip-ft.

#### 3.5.1 Load Case 1 – Section 1 Fender System - C2 Soil

The illustration of the nodes that are loaded are shown in Figure 33. Different iterations were performed modifying the applied load. Energy calculations (see Table 3) were performed until the vessel impact energy equal to or above 829 ft-kip was achieved.

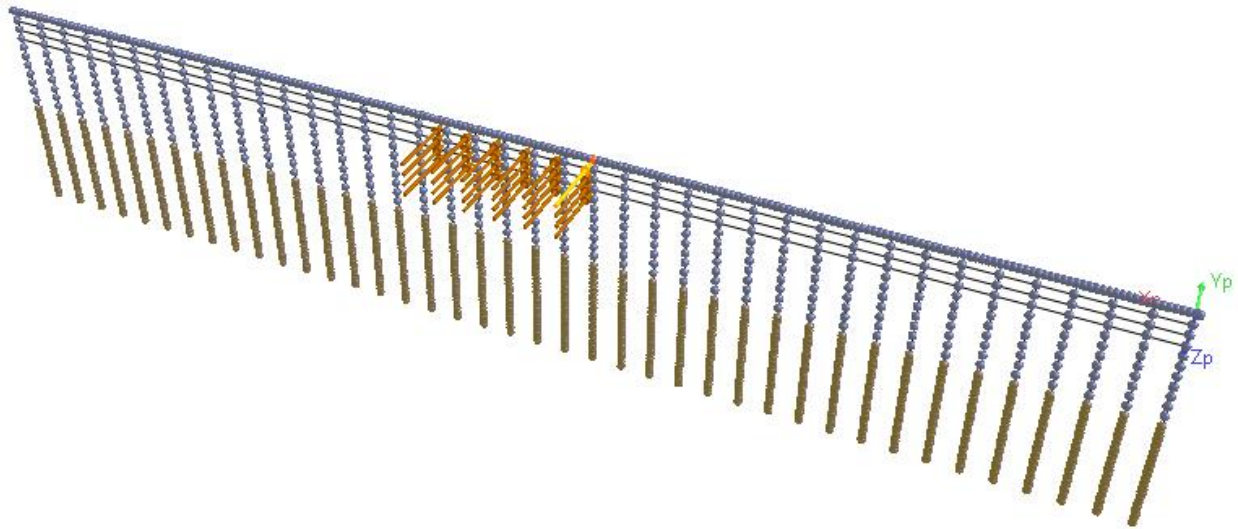

Figure 33: Layout – Load Case 1 (Section 1 – Soil C2)

Table 3: Energy Calculations - Load Case 1 (Section 1 – Soil C2)

Node	Load (kips)	Deflection (in)	Energy (ft-kips)
18	8	119.6	39.87
807	8	110	36.67
808	8	100.4	33.47
809	8	90.8	30.27
19	8	137.4	45.80
840	8	126.7	42.23
841	8	115.9	38.63
842	8	105.1	35.03
20	8	146.9	48.97
873	8	135.5	45.17
874	8	124.1	41.37
875	8	112.6	37.53
21	8	146.9	48.97
906	8	135.5	45.17
907	8	124.1	41.37
908	8	112.6	37.53
22	8	137.4	45.80
939	8	126.7	42.23
940	8	115.9	38.63
941	8	105.1	35.03
23	8	119.6	39.87
972	8	110	36.67
973	8	100.4	33.47
974	8	90.8	30.27
<b>Total Energy (ft-kip)</b>			<b>950</b>

EAC = 950 ft-kip > Emin = 829 ft-kip (Acceptable)

Pile Moment Capacity Check - Load Case 1 (Section 1 – Soil C2)

Maximum pile moment (18" Diam. x 3/4" WT pile) = 557 ft-kip (See Figure 34 below)

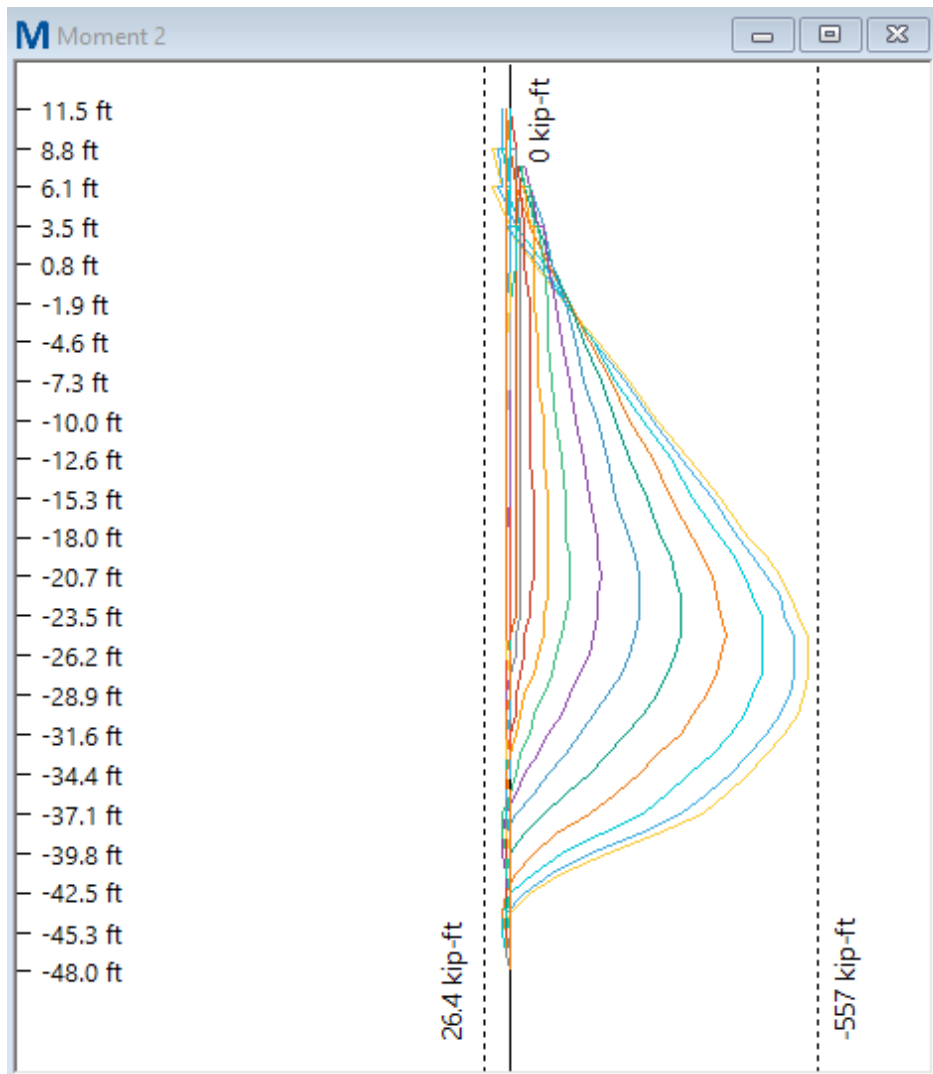

Figure 34: Max Pile Moment - Load Case 1 (Section 1-Soil C2)

**Allowable Pile Design Capacity after statistical reductions = 591 ft-kip**

**Actual of 557 ft-kip <= Allowable of 591 ft-kip (Acceptable)**

Pile Shear Capacity Check - Load Case 1 (Section 1- Soil C2)

Maximum pile moment (18" Diam. x 3/4" WT pile) = 72.4 kips (See Figure 34 below)

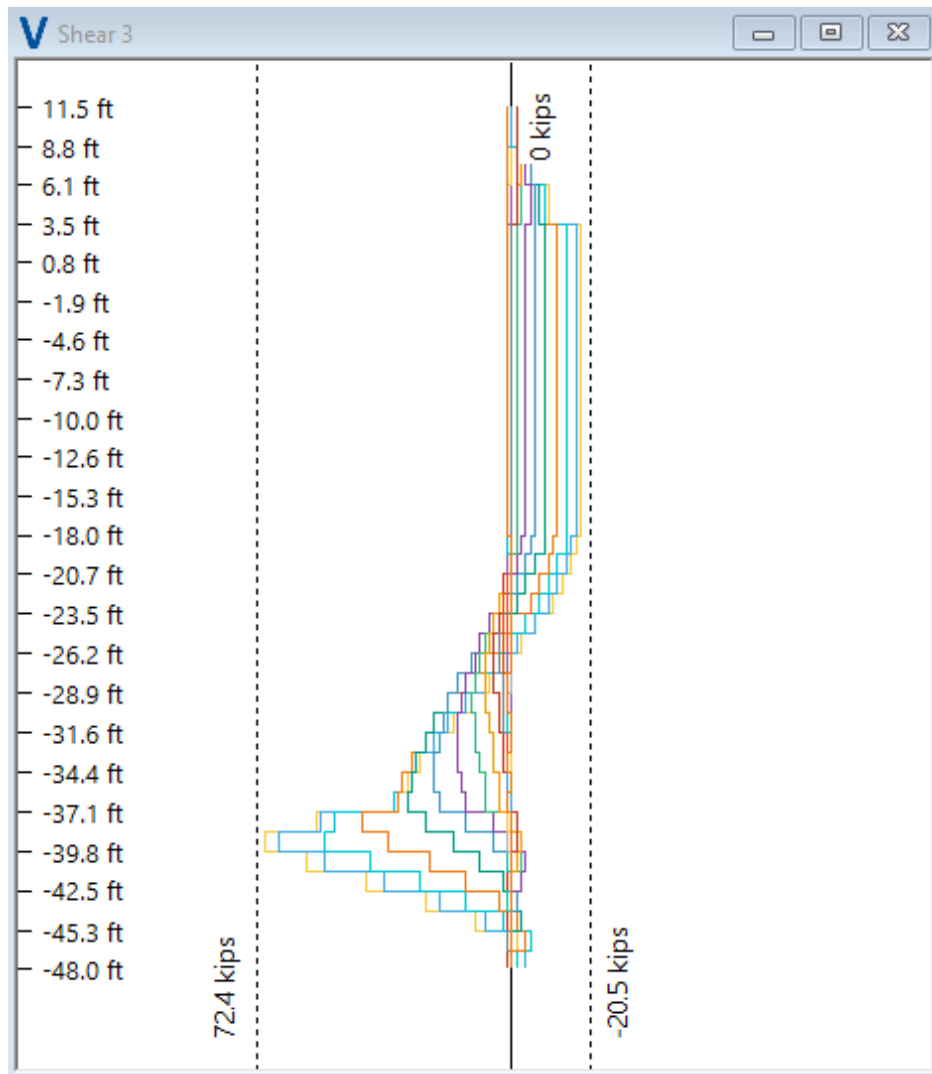

Figure 35: Max Pile Shear - Load Case 1 (Section 1 -Soil C2)

**Allowable Pile Shear Design Capacity after statistical reductions = 303.5 kip**  
**Actual of 72.4 kips <= Allowable of 303.5 kips (Acceptable)**

Wale Moment Capacity Check - Load Case 1 (Section 1- Soil C2)

Maximum wale moment (12x12 8F12) = 144 ft-kip (See Figure 36 below)

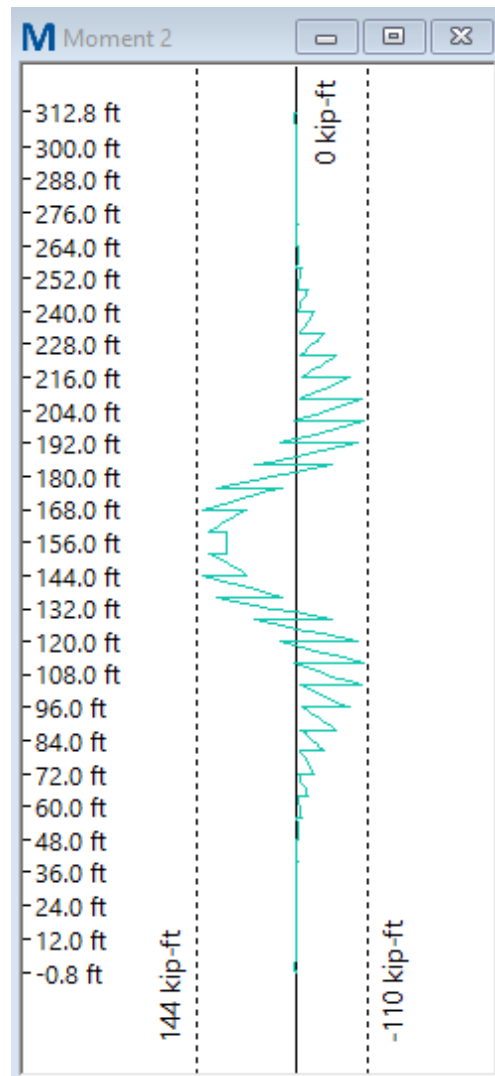

Figure 36: Max Wale Moment - Load Case 1 (Section 1-Soil C2)

**Allowable Wale Design Capacity after environment reductions = 283 ft-kip**  
**Actual of 144 ft-kip <= Allowable of 283 ft-kip (Acceptable)**

Pile Displacement Check - Load Case 1 (Section 1 – Soil C2)

See Figure 37 below.

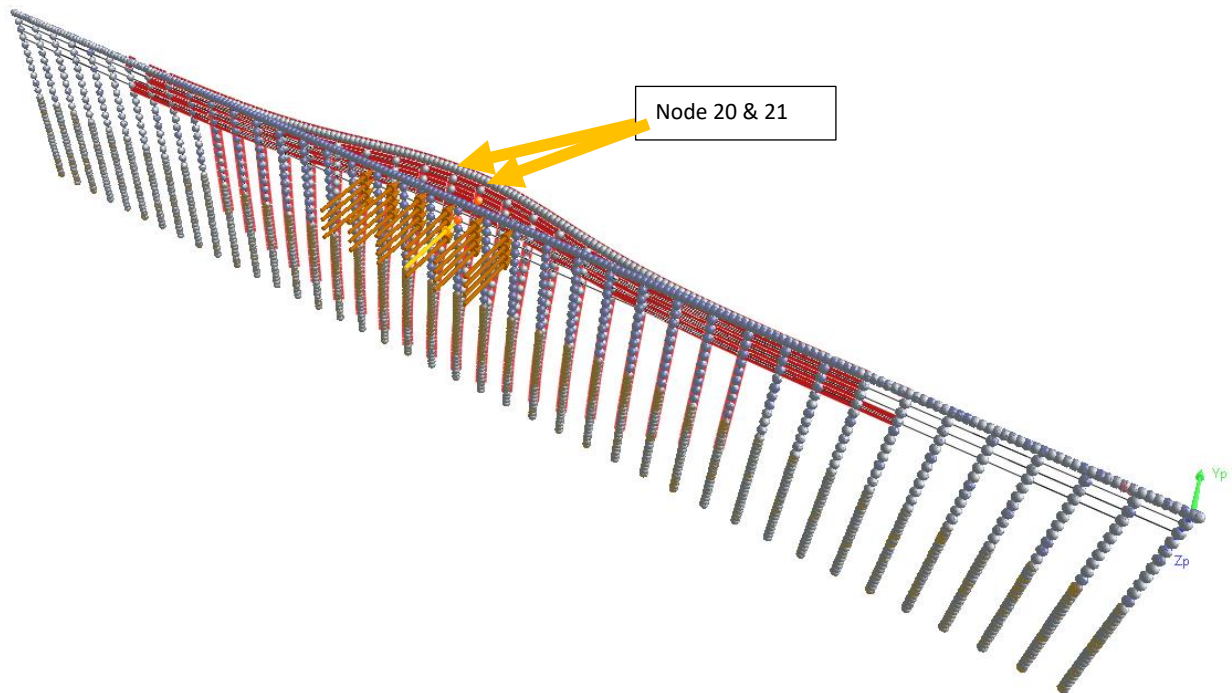

Figure 37: Displacement - Load Case 1 (Section 1-Soil C2)

**Maximum Pile displacement of system at back face is on node 20 & 21 with a displacement of 146.9 in.**

3.5.2 Load Case 2 – Section 2 Fender System – C3 Soil

The illustration of the nodes that are loaded are shown in Figure 33. Different iterations were performed modifying the applied load. Energy calculations (see Table 4) were performed until the vessel impact energy equal to or above 829 ft-kip was achieved.



Figure 38: Layout – Load Case 2 (Section 2 – Soil C3)

Table 4: Energy Calculations - Load Case 2 (Section 2 – Soil C3)

Node	Load (kips)	Deflection (in)	Energy (ft-kips)
26	10.4	84.6	36.66
1332	10.4	76.6	33.19
1333	10.4	68.5	29.68
1334	10.4	60.6	26.26
27	10.4	101.2	43.85
1362	10.4	92	39.87
1363	10.4	82.75	35.86
1364	10.4	73.5	31.85
28	10.4	110.2	47.75
1392	10.4	100.2	43.42
1393	10.4	90.3	39.13
1394	10.4	80.3	34.80
29	10.4	110.2	47.75
1422	10.4	100.2	43.42
1423	10.4	90.3	39.13
1424	10.4	80.3	34.80
30	10.4	101.2	43.85
1452	10.4	92	39.87
1453	10.4	82.75	35.86
1454	10.4	73.5	31.85
31	10.4	84.6	36.66
1482	10.4	76.6	33.19
1483	10.4	68.5	29.68
1484	10.4	60.6	26.26
<b>Total Energy (ft-kip)</b>			<b>884.65</b>

EAC = 884.65 ft-kip > Emin = 829 ft-kip (Acceptable)

Pile Moment Capacity Check - Load Case 2 (Section 2 – Soil C3)

Maximum pile moment (18" Diam. x 3/4" WT pile) = 589 ft-kip (See Figure 39 below)

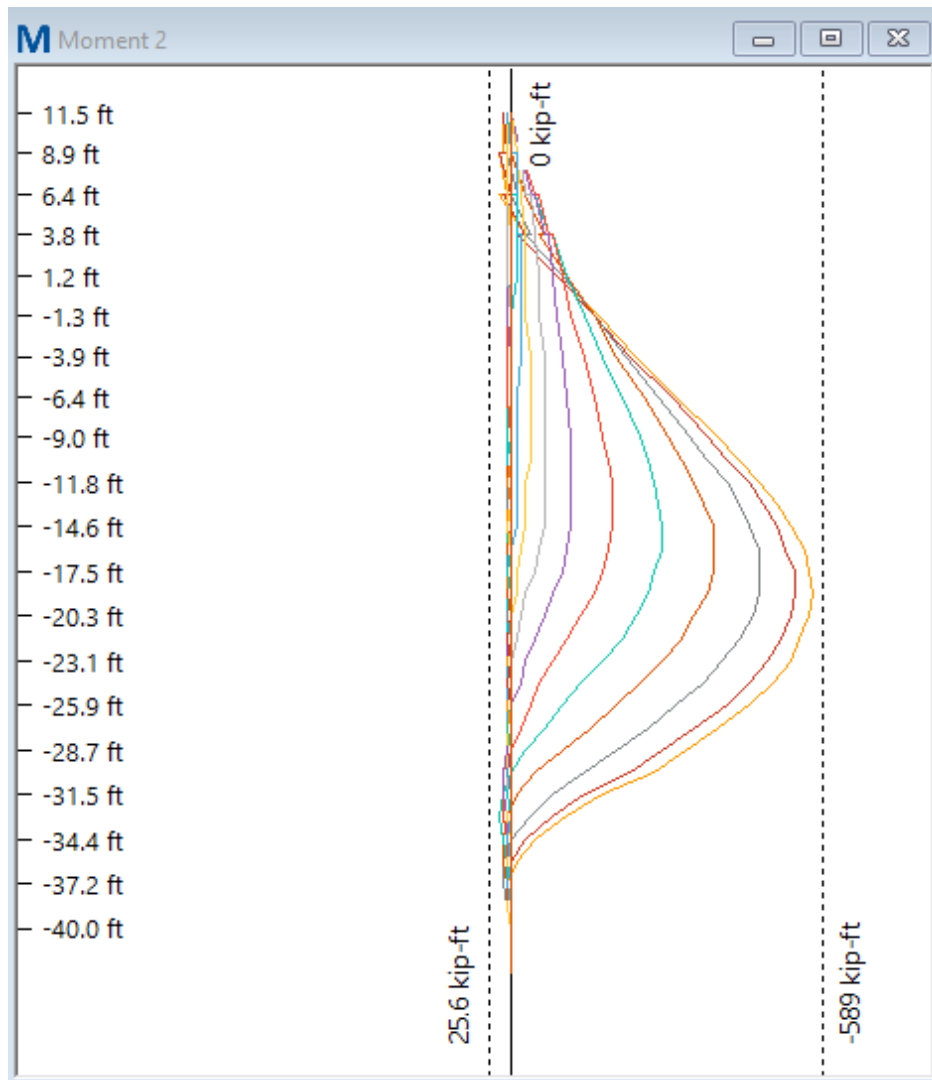

Figure 39: Max Pile Moment - Load Case 2 (Section 2 - Soil C3)

**Allowable Pile Design Capacity after statistical reductions = 591 ft-kip**

**Actual of 589 ft-kip <= Allowable of 591 ft-kip (Acceptable)**

Pile Shear Capacity Check - Load Case 2 (Section 2 – Soil C3)

Maximum pile moment (18" Diam. x 3/4" WT pile) = 63.5 kips (See Figure 40 below)

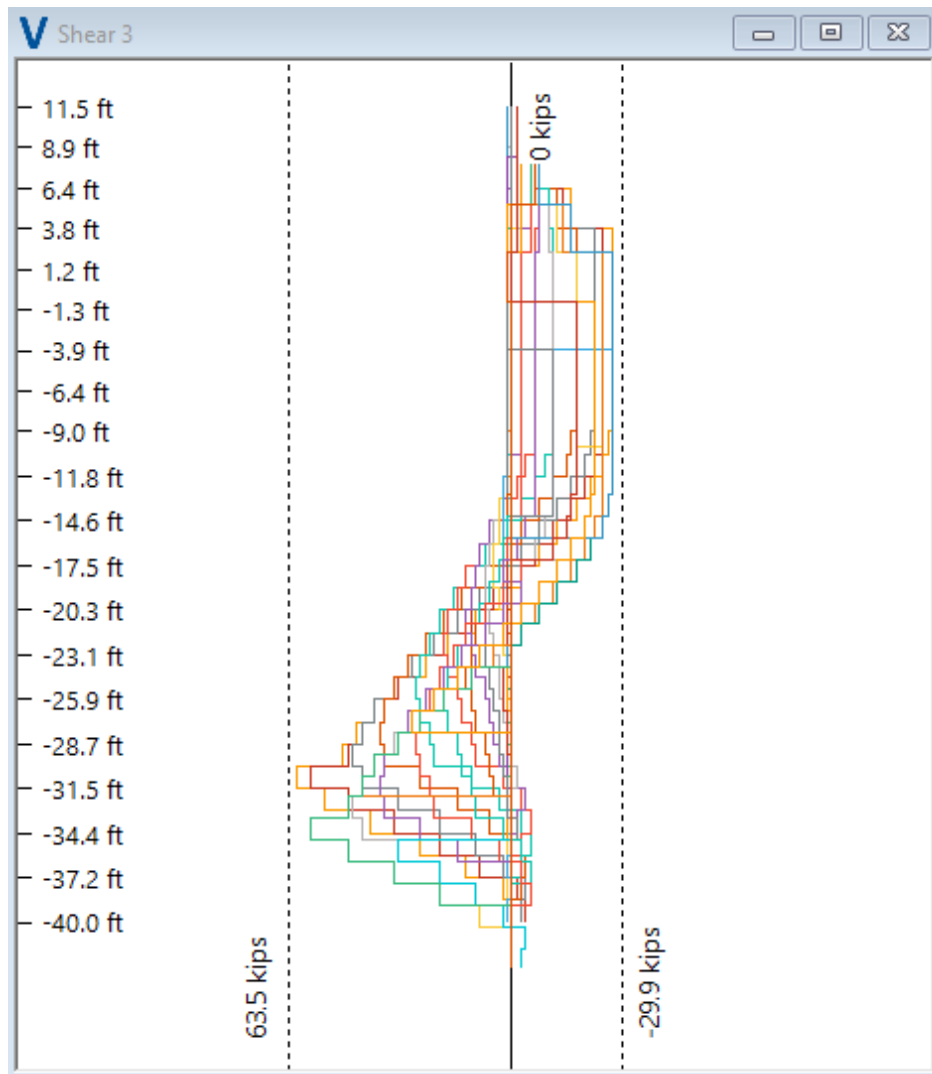

Figure 40: Max Pile Shear - Load Case 2 (Section 2 - Soil C3)

**Allowable Pile Shear Design Capacity after statistical reductions = 303.5 kip**  
**Actual of 63.5 kips <= Allowable of 303.5 kips (Acceptable)**

Wale Moment Capacity Check - Load Case 2 (Section 2 – Soil C3)

Maximum wale moment (12x12 8F12) = 141 ft-kip (See Figure 41 below)

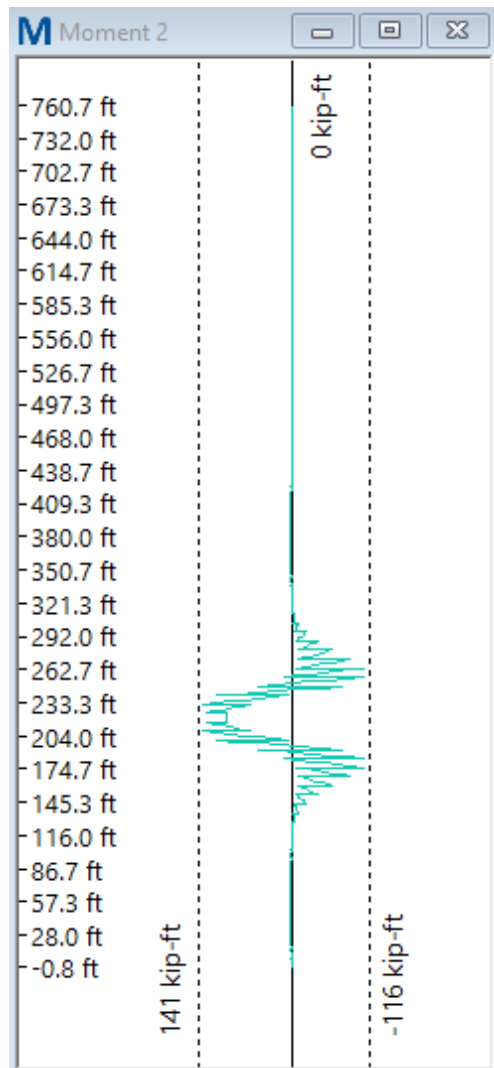

Figure 41: Max Wale Moment - Load Case 2 (Section 2-Soil C3)

**Allowable Wale Design Capacity after environment reductions = 283 ft-kip**  
**Actual of 141 ft-kip <= Allowable of 283 ft-kip (Acceptable)**

Pile Displacement Check - Load Case 2 (Section 2 – Soil C3)

See Figure 42 below.

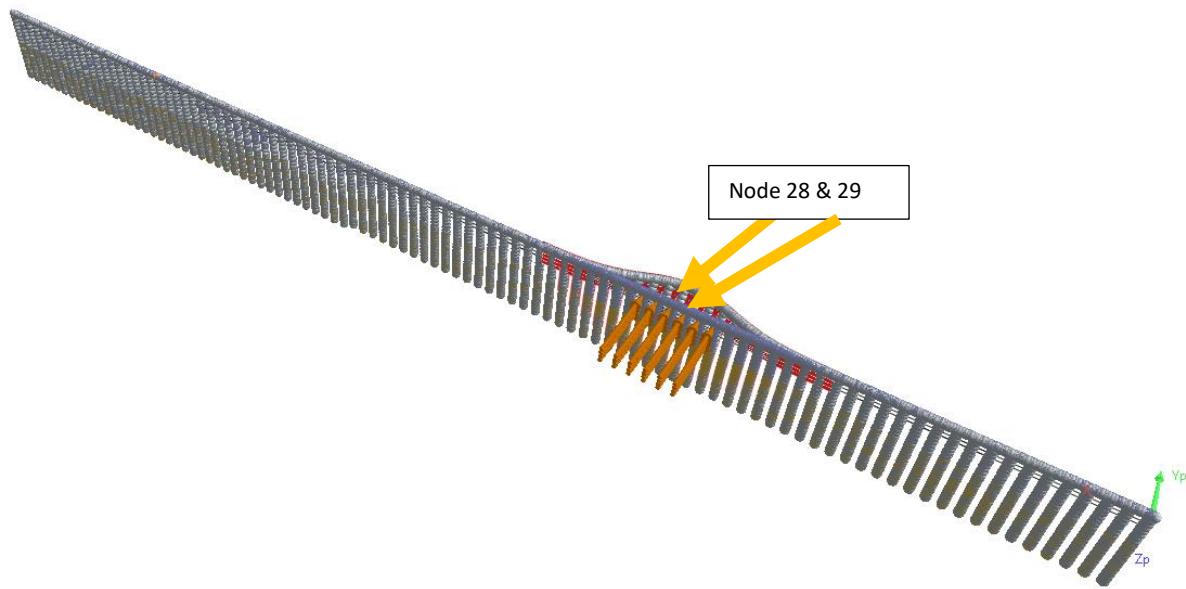

Figure 42: Displacement - Load Case 2 (Section 2 – Soil C3)

**Maximum Pile displacement of system at back face is on node 28 & 29 with a displacement of 110 in.**

3.5.3 Load Case 3 – Section 2 Fender System – C4 Soil

The illustration of the nodes that are loaded are shown in Figure 43. Different iterations were performed modifying the applied load. Energy calculations (see Table 5) were performed until the vessel impact energy equal to or above 829 ft-kip was achieved.



Figure 43: Layout – Load Case 3 (Section 2 – Soil C4)

Table 5: Energy Calculations - Load Case 3 (Section 2 – Soil C4)

Node	Load (kips)	Deflection (in)	Energy (ft-kips)
74	9.5	97.9	38.75
2772	9.5	87.87	34.78
2773	9.5	77.8	30.80
2774	9.5	67.8	26.84
75	9.5	115.2	45.60
2802	9.5	103.7	41.05
2803	9.5	92.3	36.54
2804	9.5	80.8	31.98
76	9.5	124.5	49.28
2832	9.5	99.02	39.20
2833	9.5	88.5	35.03
2834	9.5	77.97	30.86
77	9.5	124.5	49.28
2862	9.5	112.2	44.41
2863	9.5	100	39.58
2864	9.5	87.74	34.73
78	9.5	115.2	45.60
2892	9.5	103.7	41.05
2893	9.5	92.3	36.54
2894	9.5	80.8	31.98
79	9.5	97.9	38.75
2922	9.5	87.87	34.78
2923	9.5	77.8	30.80
2924	9.5	67.8	26.84
<b>Total Energy (ft-kip)</b>			<b>895.05</b>

EAC = 895.05 ft-kip > Emin = 829 ft-kip (Acceptable)

Pile Moment Capacity Check - Load Case 3 (Section 2 – Soil C4)

Maximum pile moment (18" Diam. x 3/4" WT pile) = 585 ft-kip (See Figure 44 below)

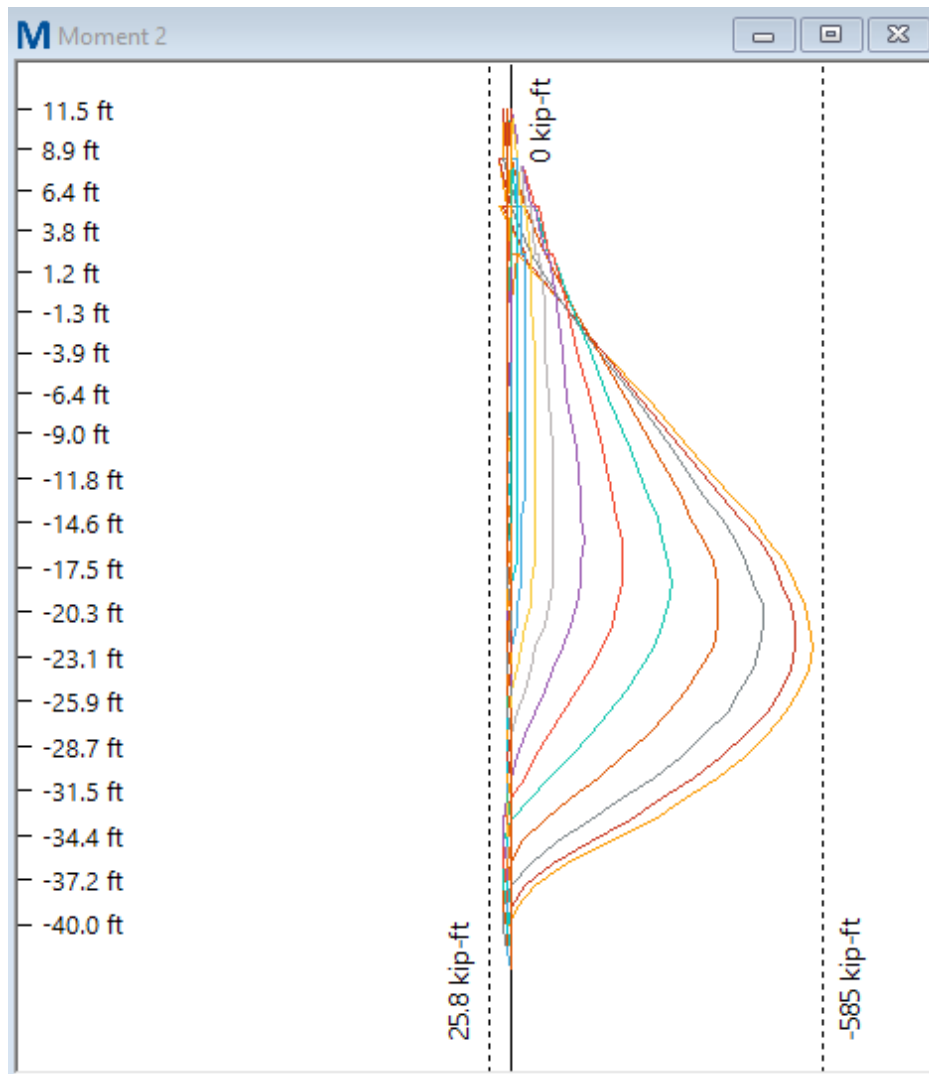

Figure 44: Max Pile Moment - Load Case 3 (Section 2 - Soil C4)

**Allowable Pile Design Capacity after statistical reductions = 591 ft-kip**  
**Actual of 585 ft-kip <= Allowable of 591 ft-kip (Acceptable)**

Pile Shear Capacity Check - Load Case 3 (Section 2 – Soil C4)

Maximum pile moment (18" Diam. x 3/4" WT pile) = 64.3 kips (See Figure 45 below)

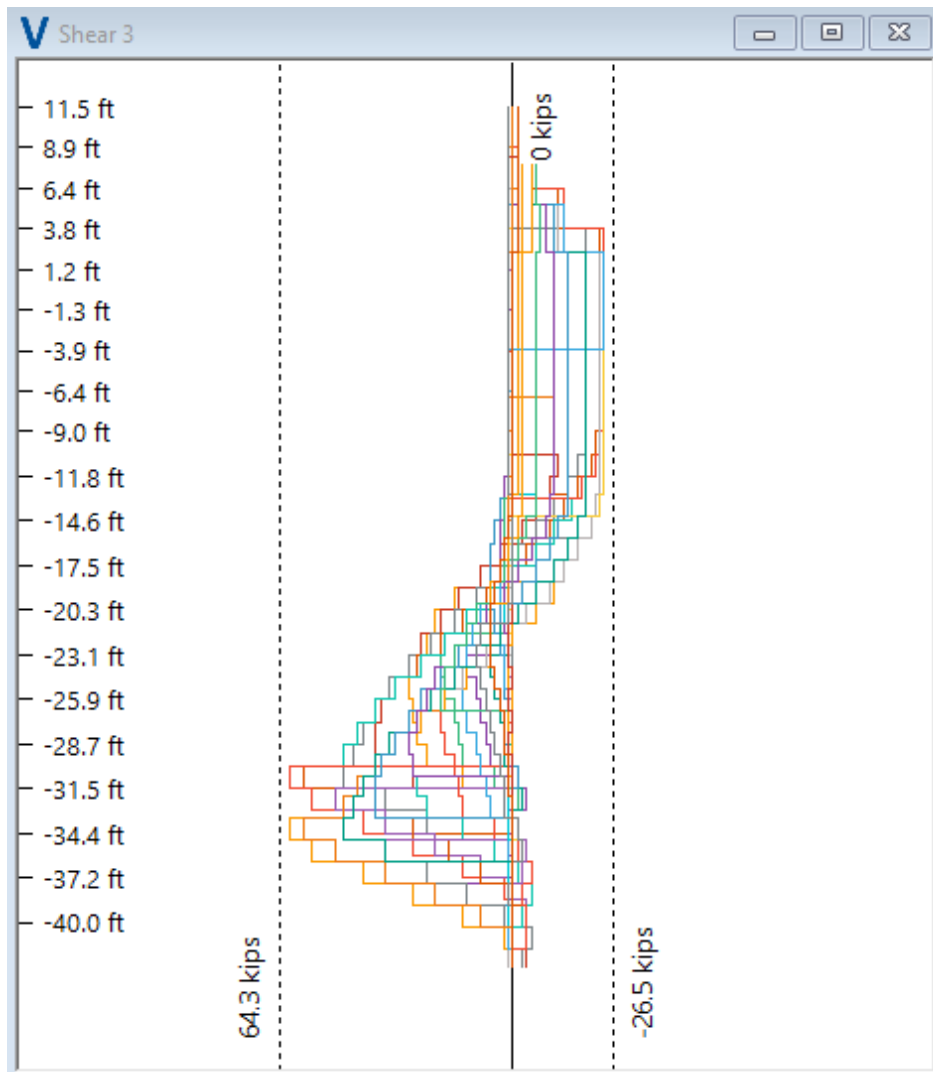

Figure 45: Max Pile Shear - Load Case 3 (Section 2 - Soil C4)

**Allowable Pile Shear Design Capacity after statistical reductions = 303.5 kip**  
**Actual of 64.3 kips <= Allowable of 303.5 kips (Acceptable)**

Wale Moment Capacity Check - Load Case 3 (Section 2 – Soil C4)

Maximum wale moment (12x12 8F12) = 145 ft-kip (See Figure 46 below)

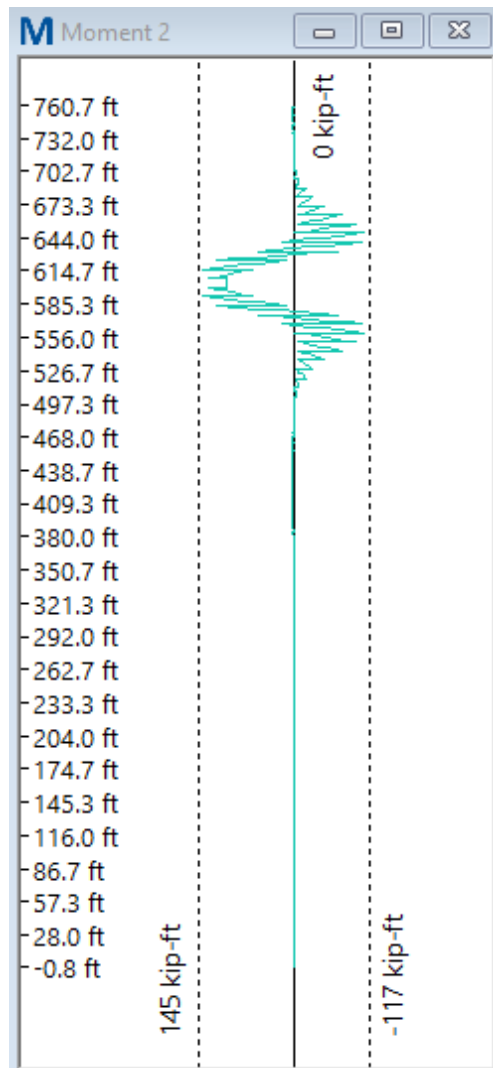

Figure 46: Max Wale Moment - Load Case 3 (Section 2 – Soil C4)

**Allowable Wale Design Capacity after environment reductions = 283 ft-kip**  
**Actual of 145 ft-kip <= Allowable of 283 ft-kip (Acceptable)**

Pile Displacement Check - Load Case 3 (Section 2 – Soil C4)

See Figure 47 below.

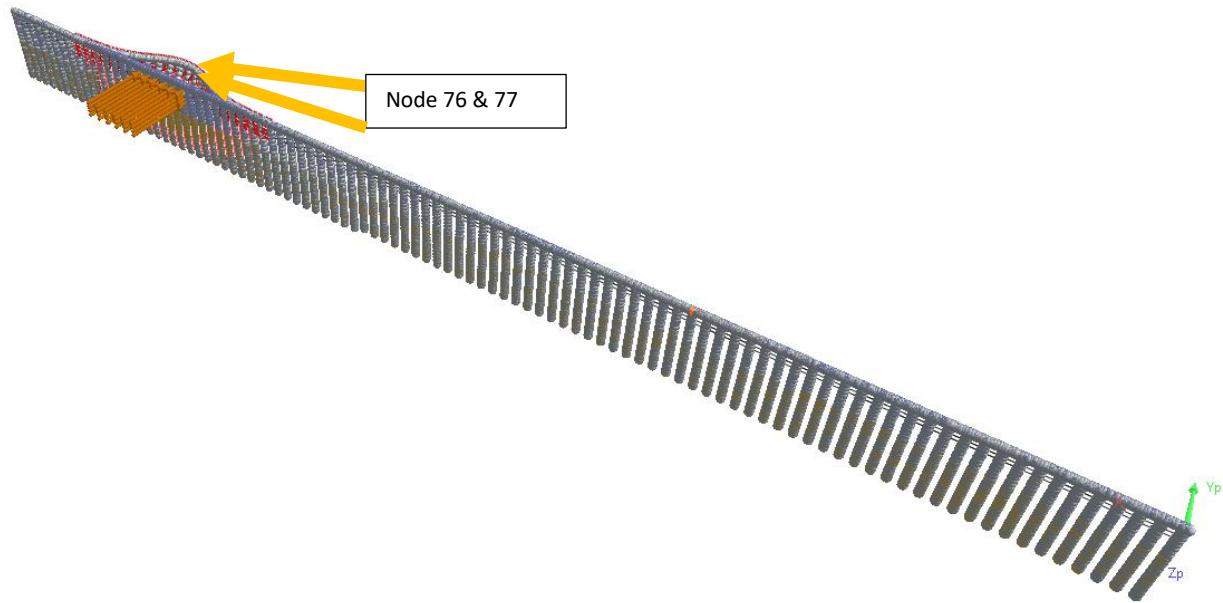

Figure 47: Displacement - Load Case 3 (Section 2 – Soil C4)

**Maximum Pile displacement of system at back face is on node 76 & 77 with a displacement of 124.5 in.**

3.5.4 Load Case 4 – Section 3 Fender System – C4 Soil

The illustration of the nodes that are loaded are shown in Figure 48. Different iterations were performed modifying the applied load. Energy calculations (see Table 6) were performed until the vessel impact energy equal to or above 829 ft-kip was achieved.

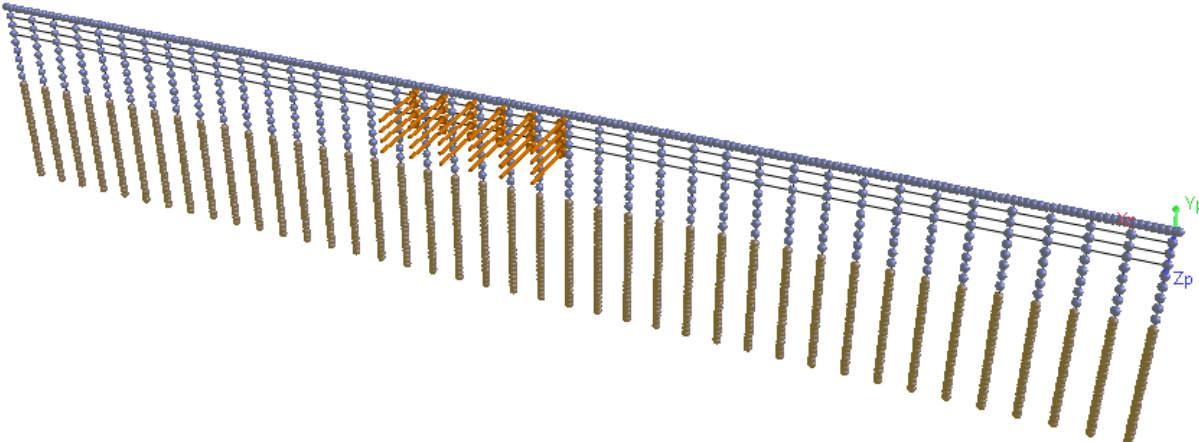

Figure 48: Layout – Load Case 4 (Section 3 – Soil C4)

Table 6: Energy Calculations - Load Case 4 (Section 3 – Soil C4)

Node	Load (kips)	Deflection (in)	Energy (ft-kips)
18	9.4	99.2	38.85
773	9.4	90.1	35.29
774	9.4	81	31.73
775	9.4	71.9	28.16
19	9.4	116.6	45.67
804	9.4	106.2	41.60
805	9.4	95.8	37.52
806	9.4	85.4	33.45
20	9.4	125.9	49.31
835	9.4	114.8	44.96
836	9.4	103.8	40.66
837	9.4	92.6	36.27
21	9.4	125.9	49.31
906	9.4	114.8	44.96
907	9.4	103.8	40.66
908	9.4	92.6	36.27
22	9.4	116.6	45.67
939	9.4	106.2	41.60
940	9.4	95.8	37.52
941	9.4	85.4	33.45
23	9.4	99.2	38.85
972	9.4	90.1	35.29
973	9.4	81	31.73
974	9.4	71.9	28.16
<b>Total Energy (ft-kip)</b>			<b>926.92</b>

EAC = 926.92 ft-kip > Emin = 829 ft-kip (Acceptable)

Pile Moment Capacity Check - Load Case 4 (Section 3 – Soil C4)

Maximum pile moment (18" Diam. x 3/4" WT pile) = 589 ft-kip (See Figure 49 below)

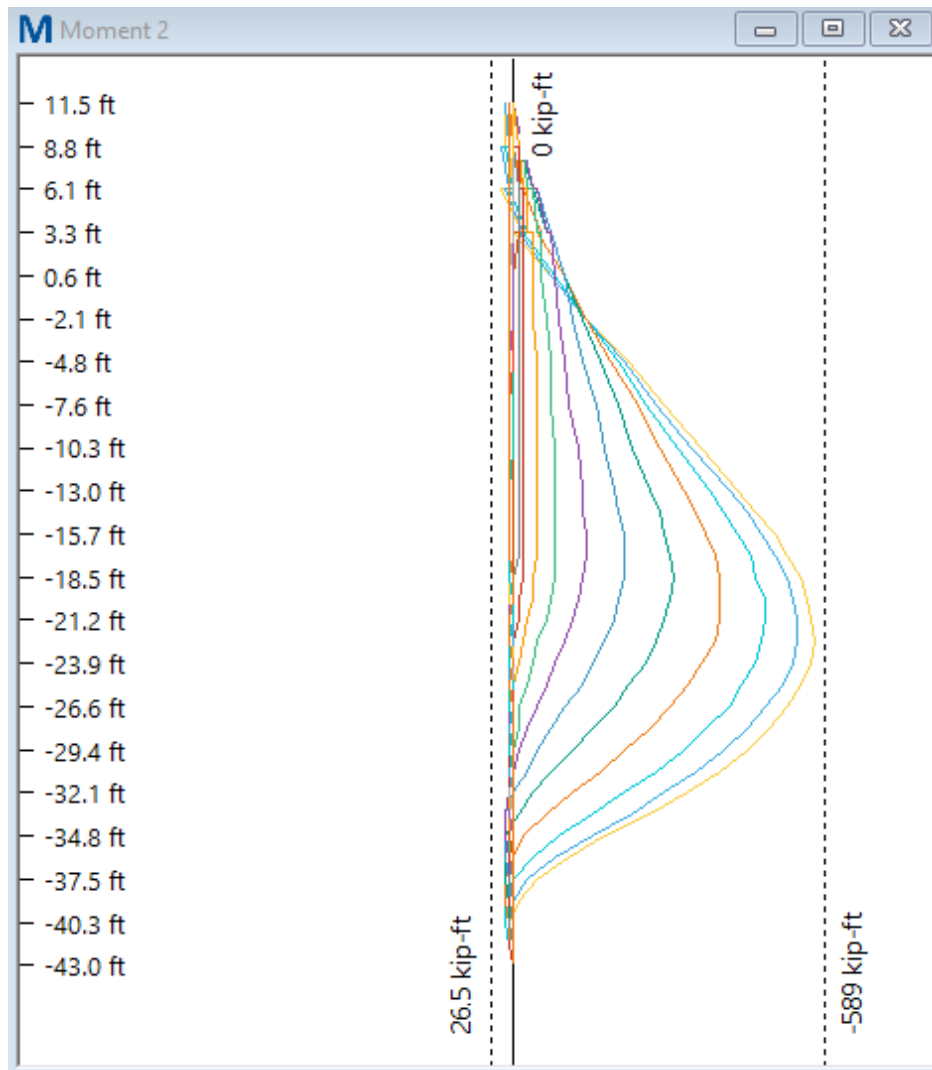

Figure 49: Max Pile Moment - Load Case 4 (Section 3 - Soil C4)

**Allowable Pile Design Capacity after statistical reductions = 591ft-kip**  
**Actual of 589 ft-kip <= Allowable of 591 ft-kip (Acceptable)**

Pile Shear Capacity Check - Load Case 4 (Section 3 – Soil C4)

Maximum pile moment (18" Diam. x 3/4" WT pile) = 64.5 kips (See Figure 50 below)

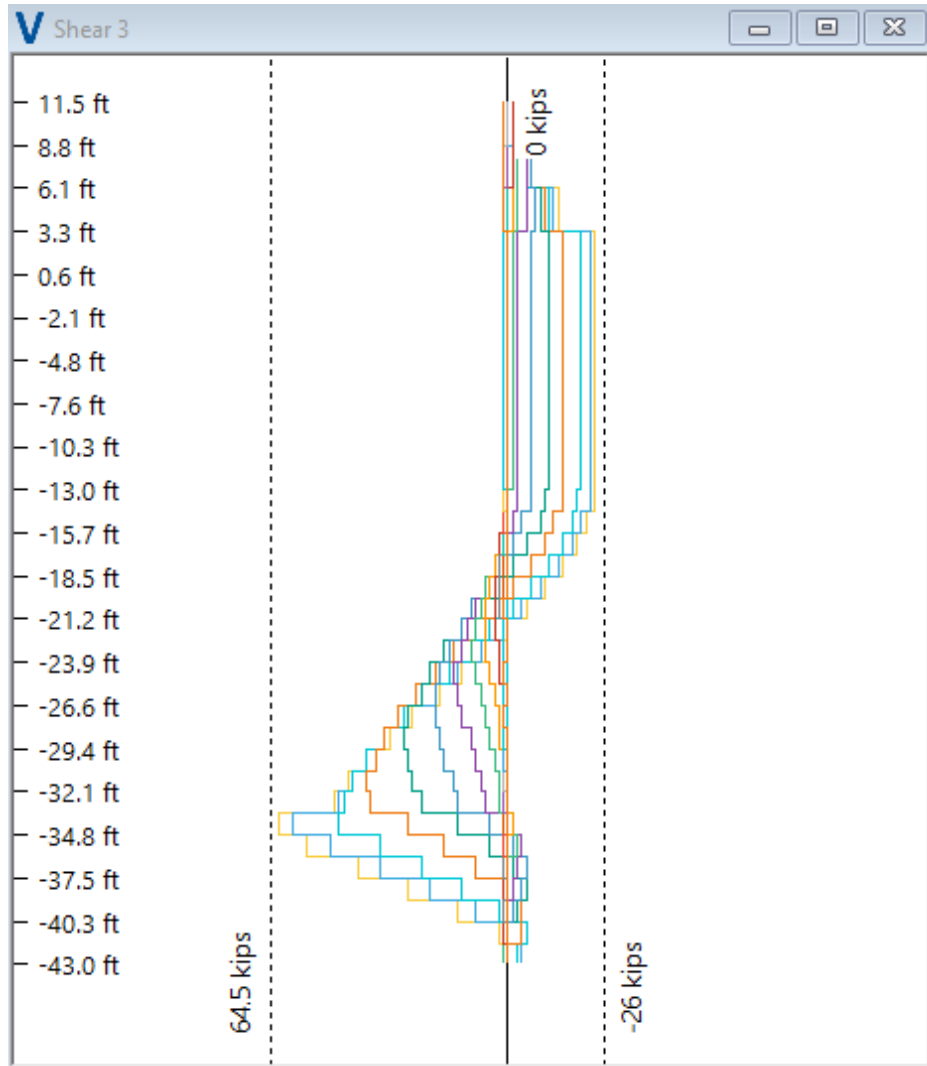

Figure 50: Max Pile Shear - Load Case 4 (Section 3 - Soil C4)

**Allowable Pile Shear Design Capacity after statistical reductions = 303.5 kip**  
**Actual of 64.5 kips <= Allowable of 303.5 kips (Acceptable)**

Wale Moment Capacity Check - Load Case 4 (Section 3 – Soil C4)

Maximum wale moment (12x12 8F12) = 144 ft-kip (See Figure 51 below)

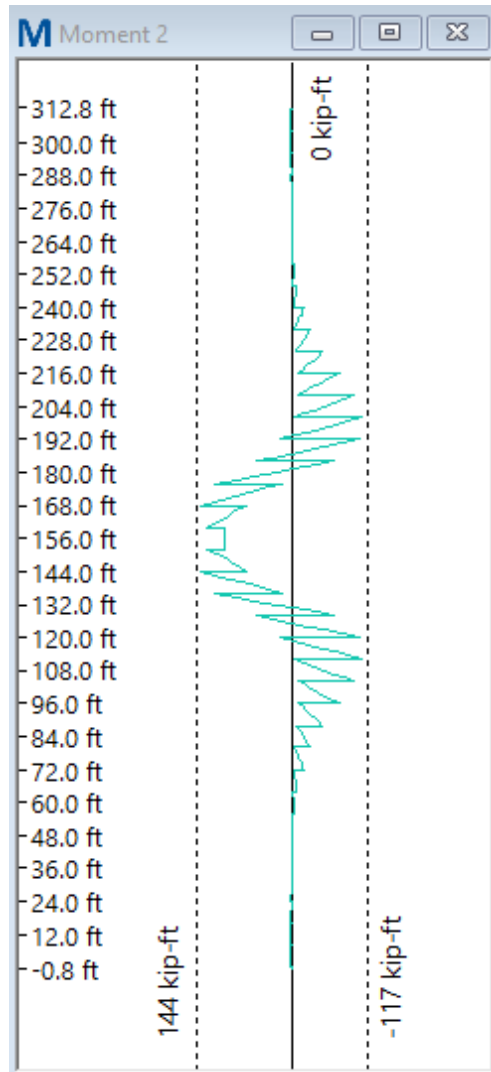

Figure 51: Max Wale Moment - Load Case 4 (Section 3 – Soil C4)

**Allowable Wale Design Capacity after environment reductions = 283 ft-kip**  
**Actual of 144 ft-kip <= Allowable of 283 ft-kip (Acceptable)**

Pile Displacement Check - Load Case 4 (Section 3 – Soil C4)

See Figure 52 below.

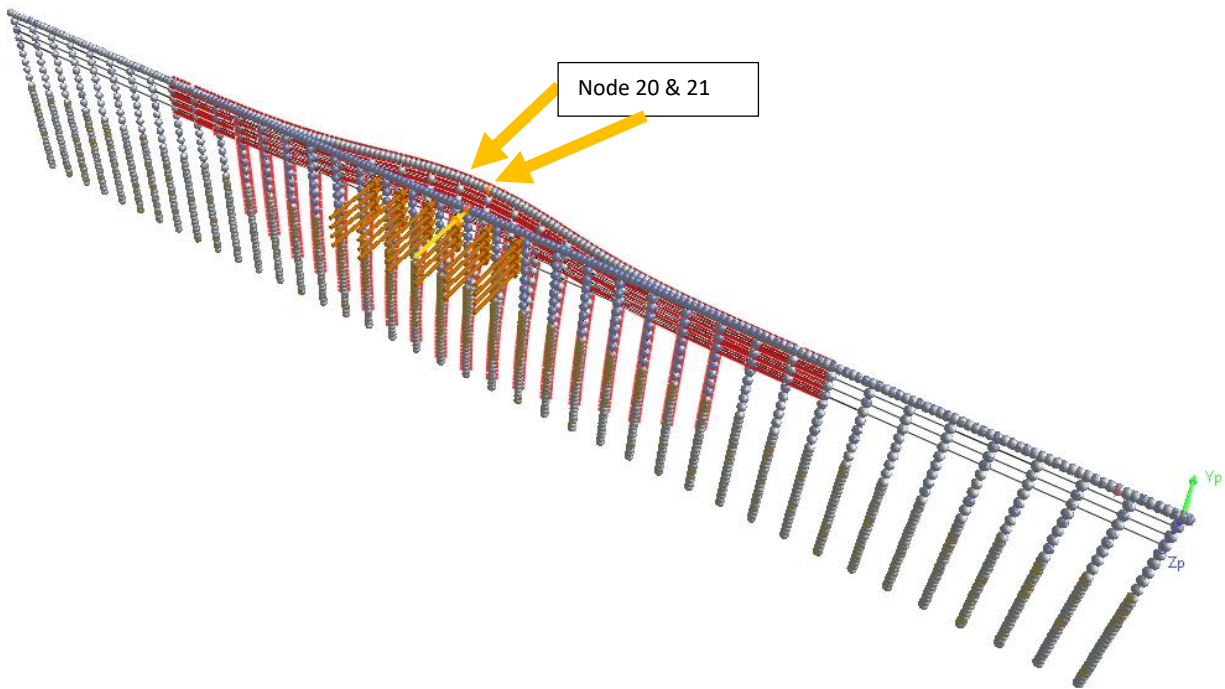

Figure 52: Displacement - Load Case 4 (Section 3 – Soil C4)

**Maximum Pile displacement of system at back face is on node 20 & 21 with a displacement of 125.9 in**

3.5.5 Load Case 5 – Section 4 Fender System – C4 Soil

The illustration of the nodes that are loaded are shown in Figure 53. Different iterations were performed modifying the applied load. Energy calculations (see Table 7) were performed until the vessel impact energy equal to or above 829 ft-kip was achieved.

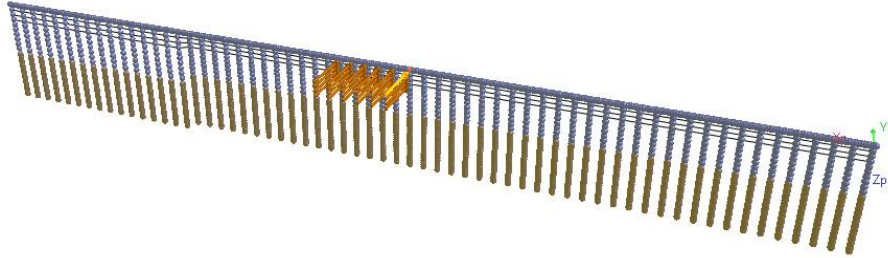

Figure 53: Layout – Load Case 5 (Section 4 – Soil C4)

Table 7: Energy Calculations - Load Case 5 (Section 4 – Soil C4)

Node	Load (kips)	Deflection (in)	Energy (ft-kips)
29	9.4	99.2	38.85
1246	9.4	90.1	35.29
1247	9.4	81	31.73
1248	9.4	71.9	28.16
30	9.4	116.6	45.67
1277	9.4	106.2	41.60
1278	9.4	95.8	37.52
1279	9.4	85.4	33.45
31	9.4	125.9	49.31
1308	9.4	114.8	44.96
1309	9.4	103.8	40.66
1310	9.4	92.6	36.27
32	9.4	125.9	49.31
1370	9.4	114.8	44.96
1371	9.4	103.8	40.66
1372	9.4	92.6	36.27
33	9.4	116.6	45.67
1402	9.4	106.2	41.60
1403	9.4	95.8	37.52
1404	9.4	85.4	33.45
34	9.4	99.2	38.85
1434	9.4	90.1	35.29
1435	9.4	81	31.73
1436	9.4	71.9	28.16
<b>Total Energy (ft-kip)</b>			<b>926.92</b>

$EAC = 926.92 \text{ ft-kip} > E_{min} = 829 \text{ ft-kip}$  (Acceptable)

Pile Moment Capacity Check - Load Case 5 (Section 4 – Soil C4)

Maximum pile moment (18" Diam. x 3/4" WT pile) = 589 ft-kip (See Figure 54 below)

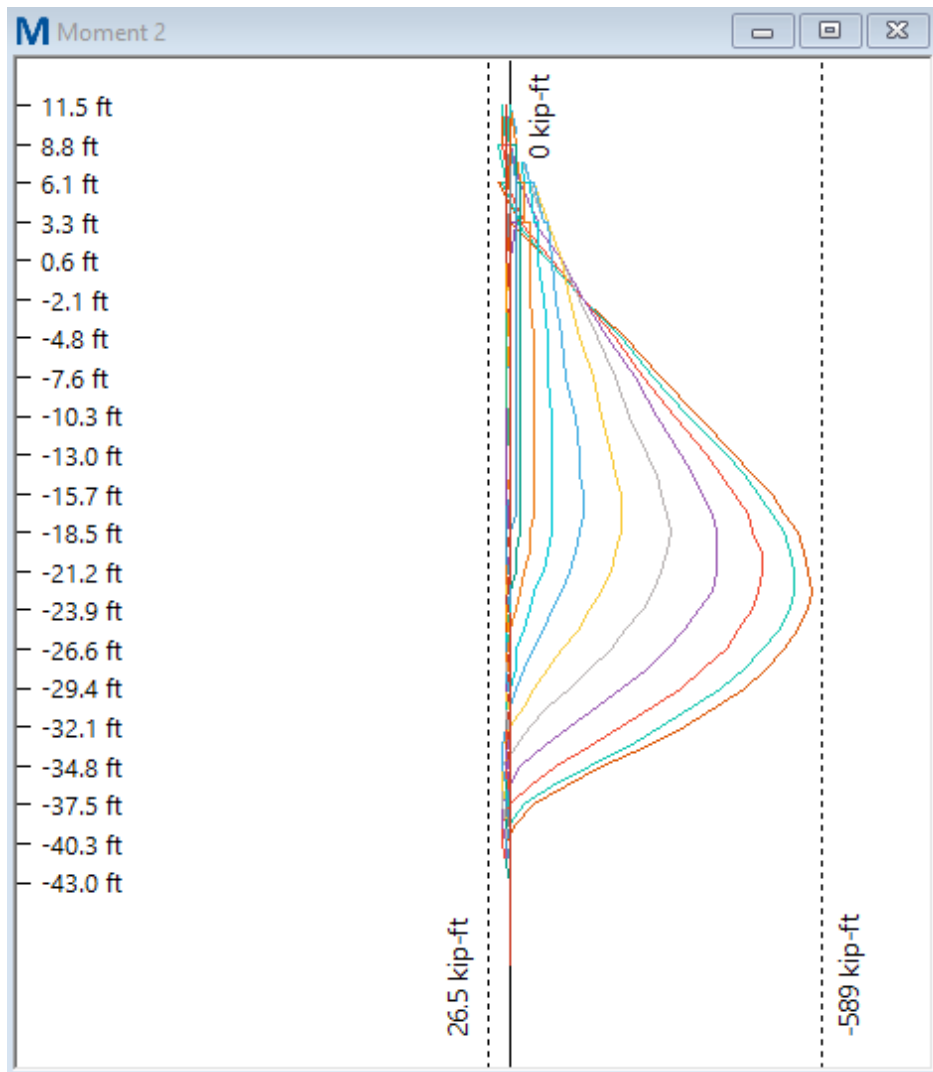

Figure 54: Max Pile Moment - Load Case 5 (Section 4 - Soil C4)

**Allowable Pile Design Capacity after statistical reductions = 591 ft-kip**  
**Actual of 589 ft-kip <= Allowable of 591 ft-kip (Acceptable)**

Pile Shear Capacity Check - Load Case 5 (Section 4 – Soil C4)

Maximum pile moment (18" Diam. x 3/4" WT pile) = 64.5 kips (See Figure 55 below)

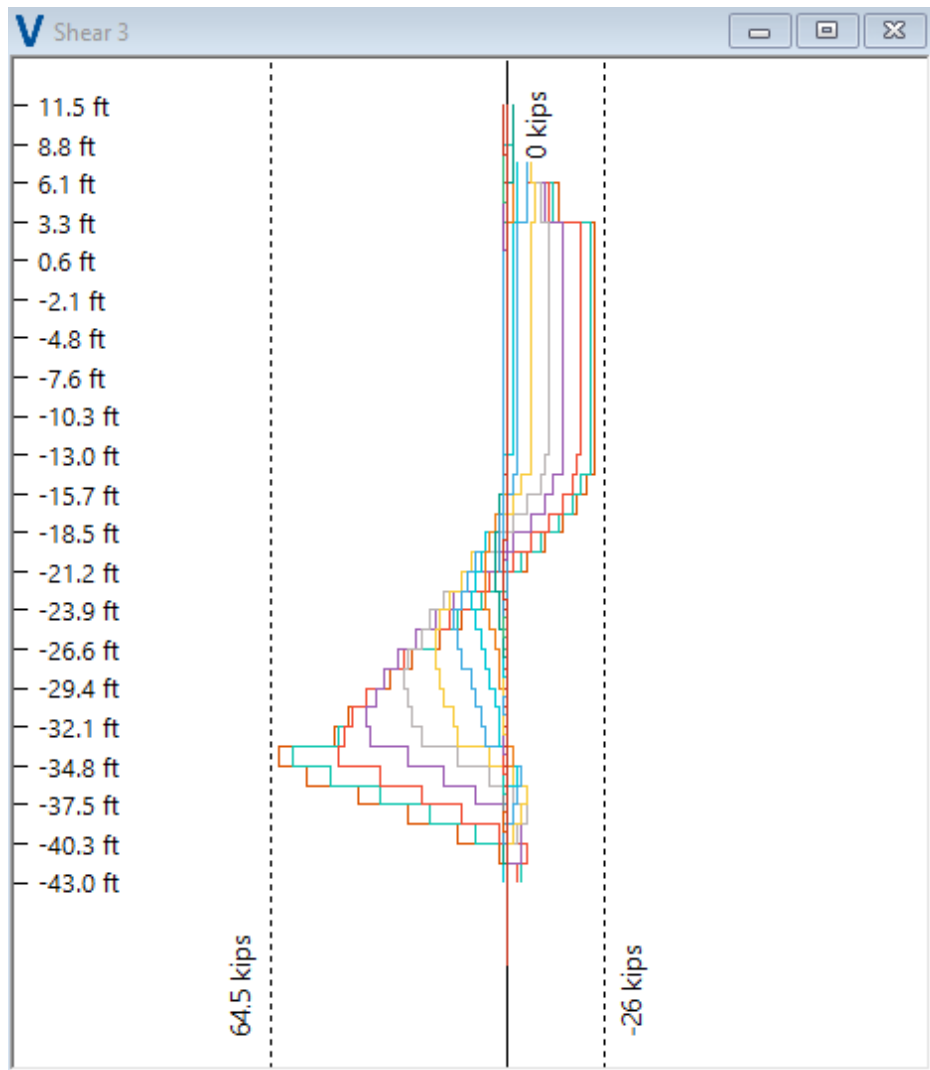

Figure 55: Max Pile Shear - Load Case 5 (Section 4 - Soil C4)

**Allowable Pile Shear Design Capacity after statistical reductions = 303.5 kip**  
**Actual of 64.5 kips <= Allowable of 303.5 kips (Acceptable)**

Wale Moment Capacity Check - Load Case 5 (Section 4 – Soil C4)

Maximum wale moment (12x12 8F12) = 144 ft-kip (See Figure 56 below)

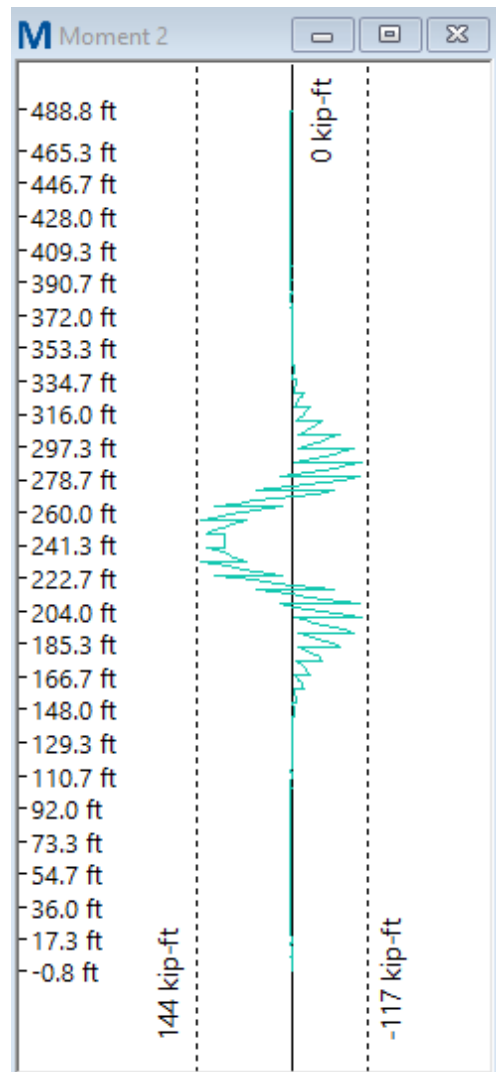

Figure 56: Max Wale Moment - Load Case 5 (Section 4 – Soil C4)

**Allowable Wale Design Capacity after environment reductions = 283 ft-kip**  
**Actual of 144 ft-kip <= Allowable of 283 ft-kip (Acceptable)**

Pile Displacement Check - Load Case 5 (Section 4 – Soil C4)

See Figure 57 below.

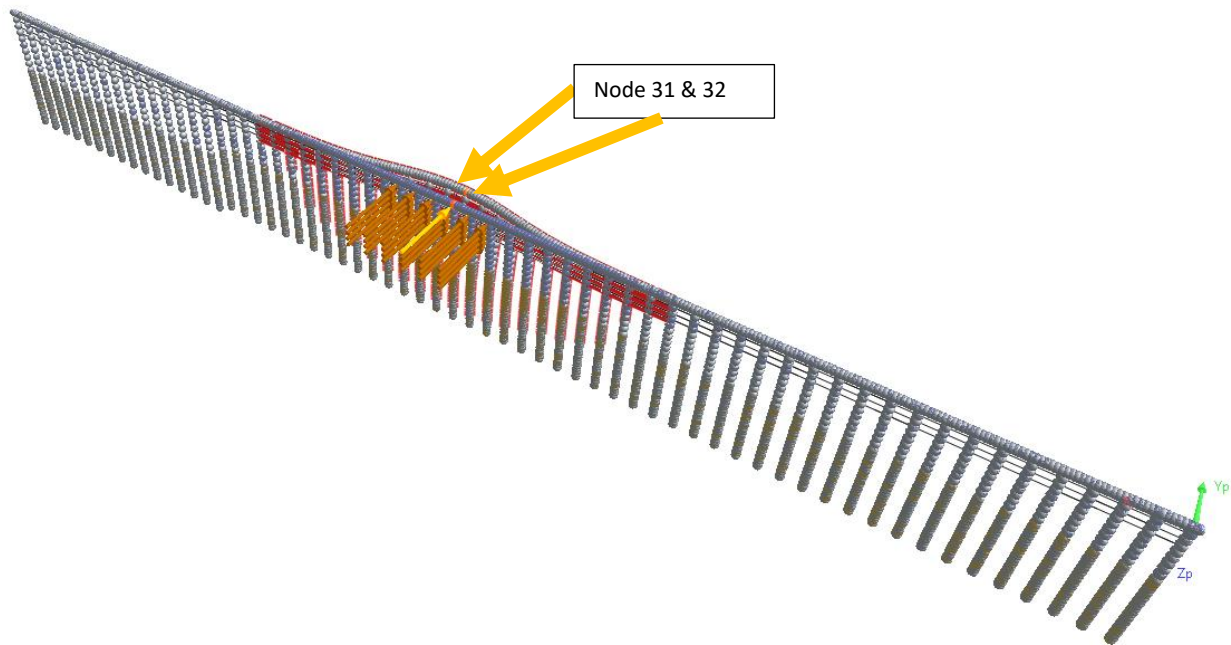

Figure 57: Displacement - Load Case 5 (Section 4 – Soil C4)

**Maximum Pile displacement of system at back face is on node 31 & 32 with a displacement of 125.9 in**

3.5.6 Load Case 6 – Section 4 Fender System – C5 Soil

The illustration of the nodes that are loaded are shown in Figure 58. Different iterations were performed modifying the applied load. Energy calculations (see Table 8) were performed until the vessel impact energy equal to or above 829 ft-kip was achieved.

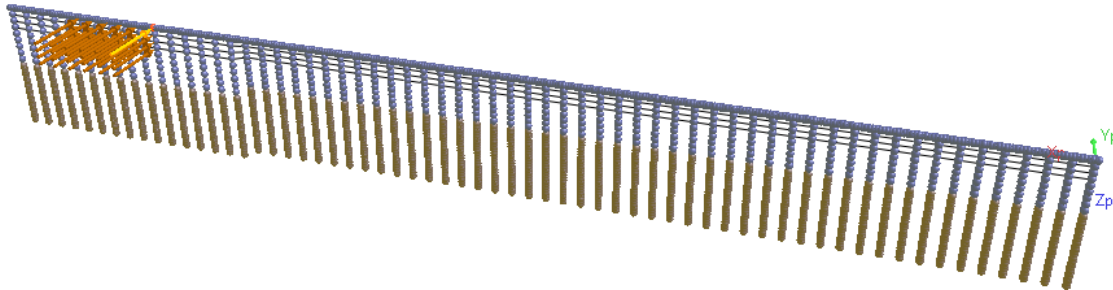

Figure 58: Layout – Load Case 6 (Section 4 – Soil C5)

Table 8: Energy Calculations - Load Case 6 (Section 4 – Soil C5)

Node	Load (kips)	Deflection (in)	Energy (ft-kips)
52	8.3	117.5	40.64
1959	8.3	105.6	36.52
1960	8.3	93.7	32.40
1961	8.3	81.9	28.32
53	8.3	135.5	46.86
1990	8.3	122.2	42.26
1991	8.3	108.8	37.63
1992	8.3	95.45	33.01
54	8.3	145.5	50.32
2021	8.3	131.3	45.41
2022	8.3	117	40.46
2023	8.3	102.8	35.55
55	8.3	145.5	50.32
2052	8.3	131.3	45.41
2053	8.3	117	40.46
2054	8.3	102.8	35.55
56	8.3	135.5	46.86
2083	8.3	122.2	42.26
2084	8.3	108.8	37.63
2085	8.3	95.45	33.01
57	8.3	117.5	40.64
2114	8.3	105.6	36.52
2115	8.3	93.7	32.40
2116	8.3	81.9	28.32
<b>Total Energy (ft-kip)</b>			<b>938.76</b>

EAC = 938.76 ft-kip > Emin = 829 ft-kip (Acceptable)

Pile Moment Capacity Check - Load Case 6 (Section 4 – Soil C5)

Maximum pile moment (18" Diam. x 3/4" WT pile) = 583 ft-kip (See Figure 59 below)

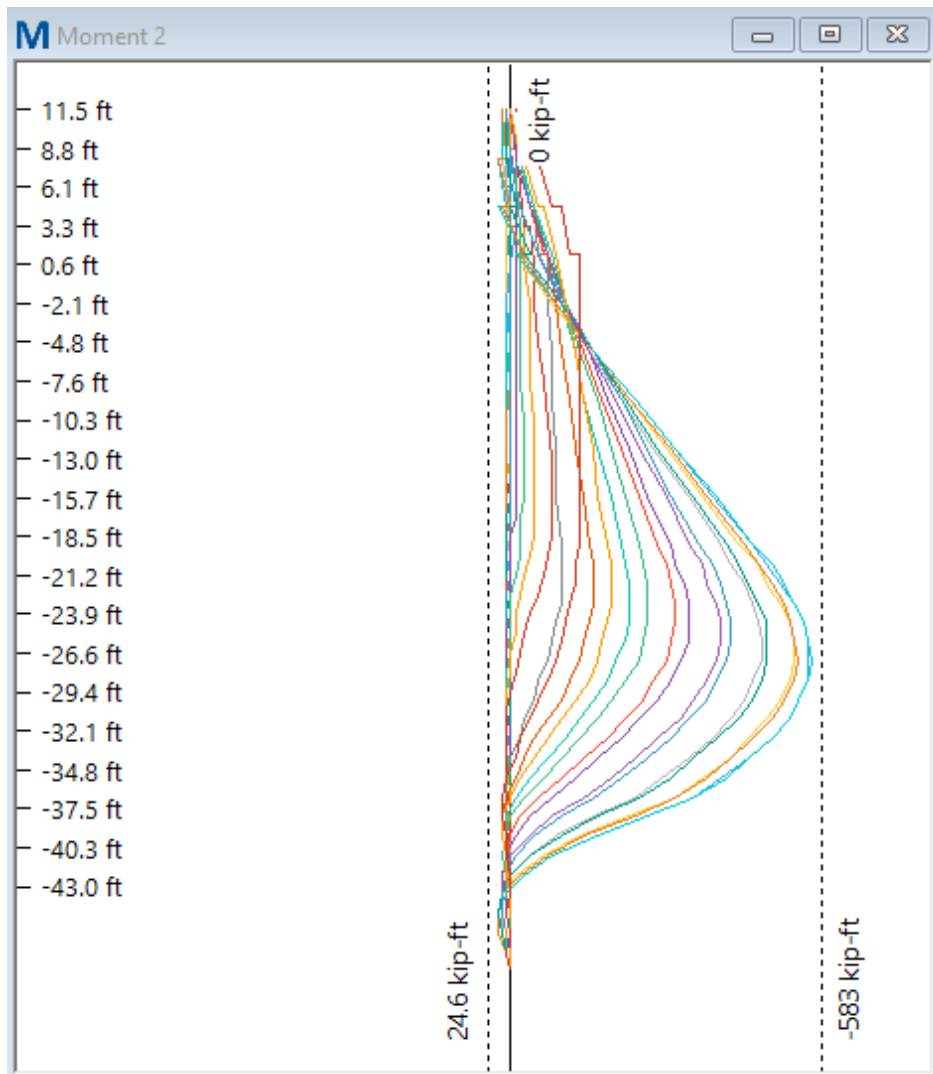

Figure 59: Max Pile Moment - Load Case 6 (Section 4 - Soil C5)

**Allowable Pile Design Capacity after statistical reductions = 591 ft-kip**

**Actual of 583 ft-kip <= Allowable of 591 ft-kip (Acceptable)**

Pile Shear Capacity Check - Load Case 6 (Section 4 – Soil C5)

Maximum pile moment (18" Diam. x 3/4" WT pile) = 75 kips (See Figure 60 below)

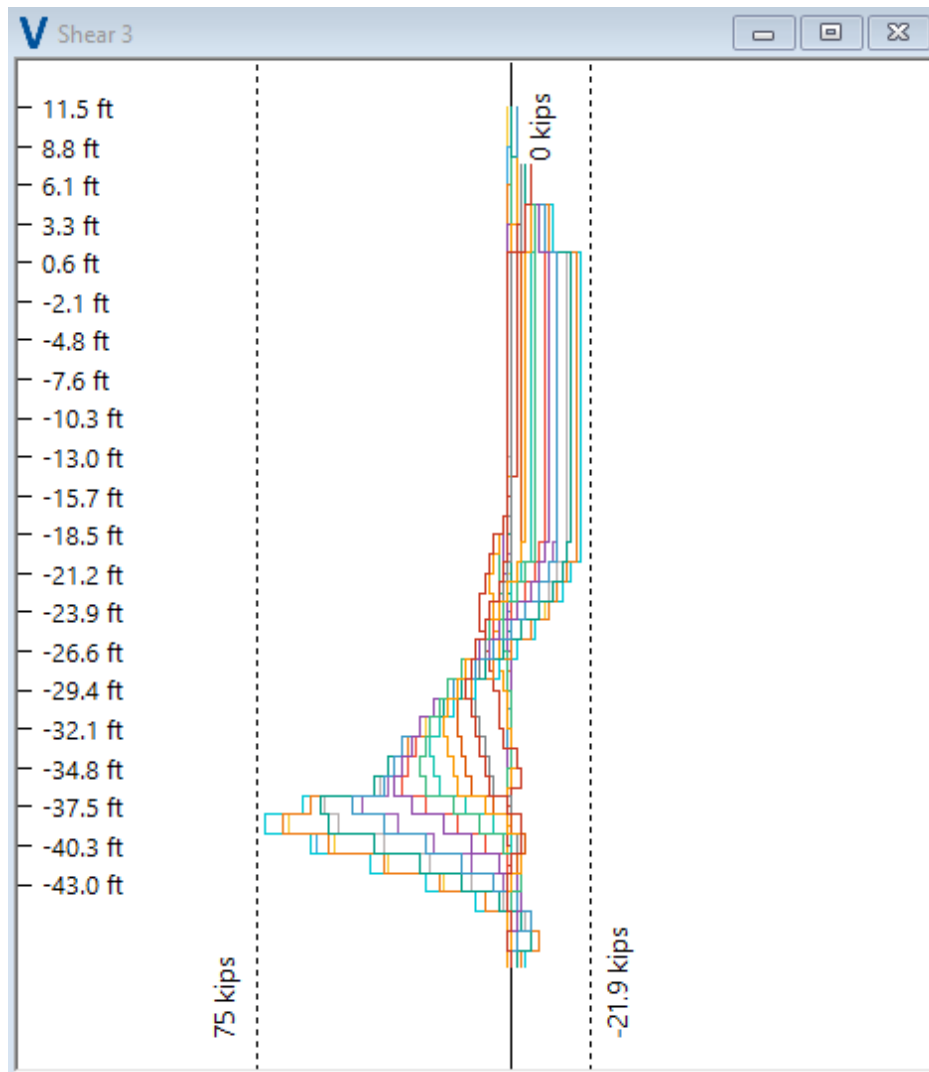

Figure 60: Max Pile Shear - Load Case 6 (Section 4 - Soil C5)

**Allowable Pile Shear Design Capacity after statistical reductions = 303.5 kip**  
**Actual of 75 kips <= Allowable of 303.5 kips (Acceptable)**

Wale Moment Capacity Check - Load Case 6 (Section 4 – Soil C5)

Maximum wale moment (12x12 8F12) = 144 ft-kip (See Figure 61 below)

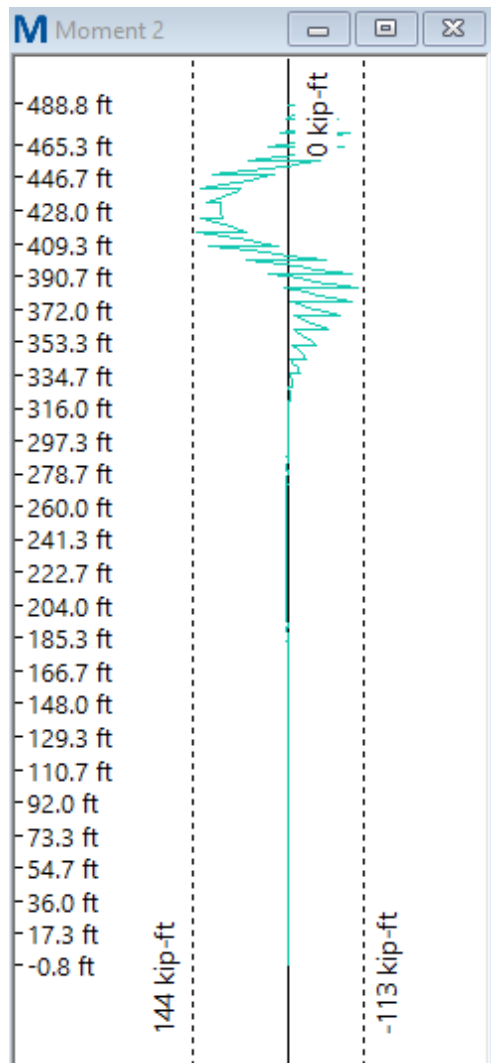

Figure 61: Max Wale Moment - Load Case 6 (Section 4 – Soil C5)

**Allowable Wale Design Capacity after environment reductions = 283 ft-kip**  
**Actual of 144 ft-kip <= Allowable of 283 ft-kip (Acceptable)**

Pile Displacement Check - Load Case 6 (Section 4 – Soil C5)

See Figure 62 below.



Figure 62: Displacement - Load Case 6 (Section 4 – Soil C5)

**Maximum Pile displacement of system at back face is on node 54 & 55 with a displacement of 145.5**

### 3.6 Low Water Energy Analysis and Calculations

The fender system was analyzed in FB Multiplier using a non-linear analysis to determine the energy absorption, maximum moments, and deflections for each load case. Each section of the fender system was analyzed separately to determine the sufficiency to absorb the required 829 kip-ft. These load cases are to simulate a barge impact event during low water when the barge would only impact one row of wales. This is a conservative analysis as the barge load would eventually be distributed onto the piles as the system deflects.

#### 3.6.1 Load Case 7 – Section 1 Fender System – C2 Soil

The illustration of the nodes that are loaded are shown in Figure 63. Different iterations were performed modifying the applied load. Energy calculations (see Table 9) were performed until the vessel impact energy equal to or above 829 ft-kip was achieved.

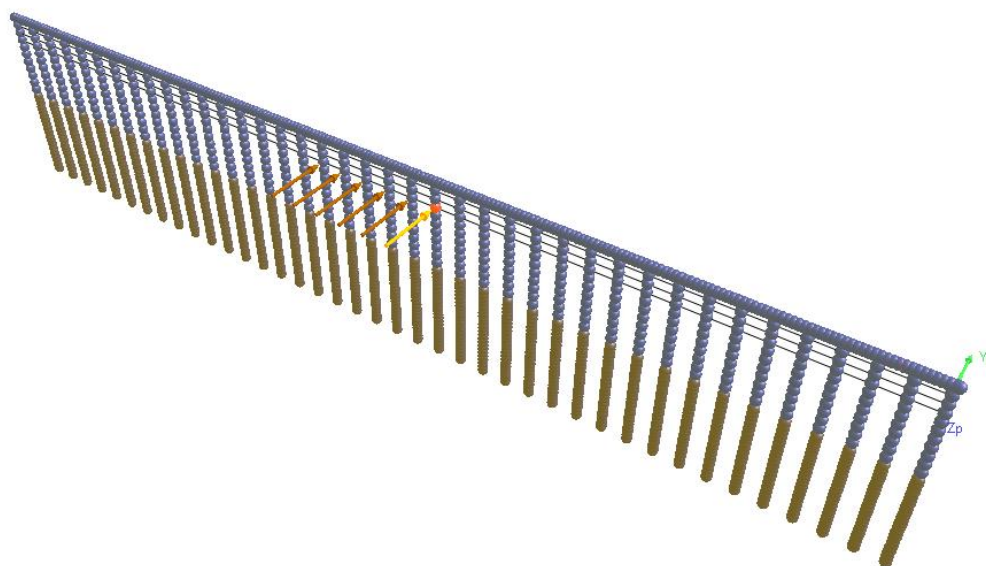

Figure 63: Layout – Load Case 7 (Section 1 – Soil C2)

Table 9: Energy Calculations - Load Case 7 (Section 1 – Soil C2)

Node	Load (kips)	Deflection (in)	Energy (ft-kips)
809	35	86.77	126.54
842	35	100.9	147.15
875	35	108.3	157.94
908	35	108.3	157.94
941	35	100.9	147.15
974	35	86.77	126.54
<b>Total Energy (ft-kip)</b>			<b>863.25</b>

EAC = 863.25 ft-kip > Emin = 829 ft-kip (Acceptable)

Pile Moment Capacity Check - Load Case 7 (Section 1 – Soil C2)

Maximum pile moment (18" Diam. x 3/4" WT pile) = 544 ft-kip (See Figure 64 below)

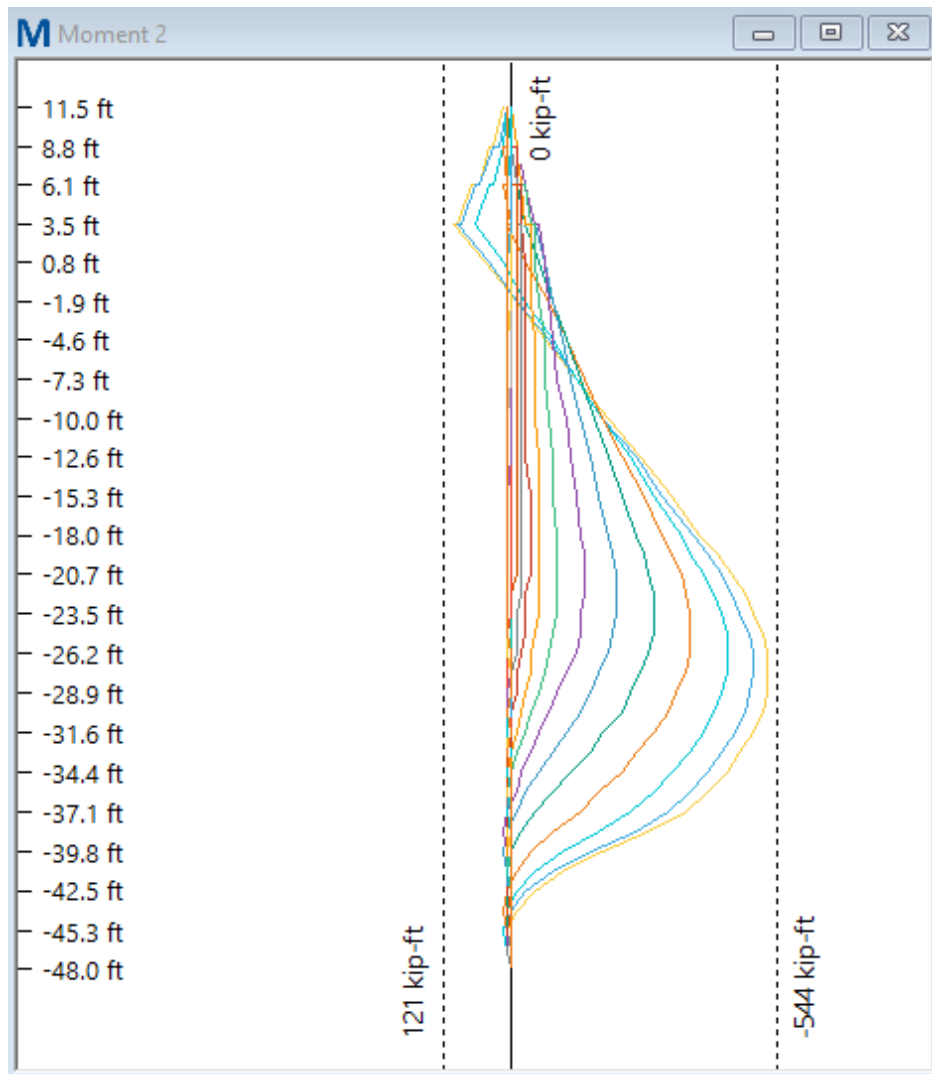

Figure 64: Max Pile Moment - Load Case 7 (Section 1-Soil C2)

**Allowable Pile Design Capacity after statistical reductions = 591 ft-kip**  
**Actual of 544 ft-kip <= Allowable of 591 ft-kip (Acceptable)**

Pile Shear Capacity Check - Load Case 7 (Section 1- Soil C2)

Maximum pile moment (18" Diam. x 3/4" WT pile) = 73.9 kips (See Figure 65 below)

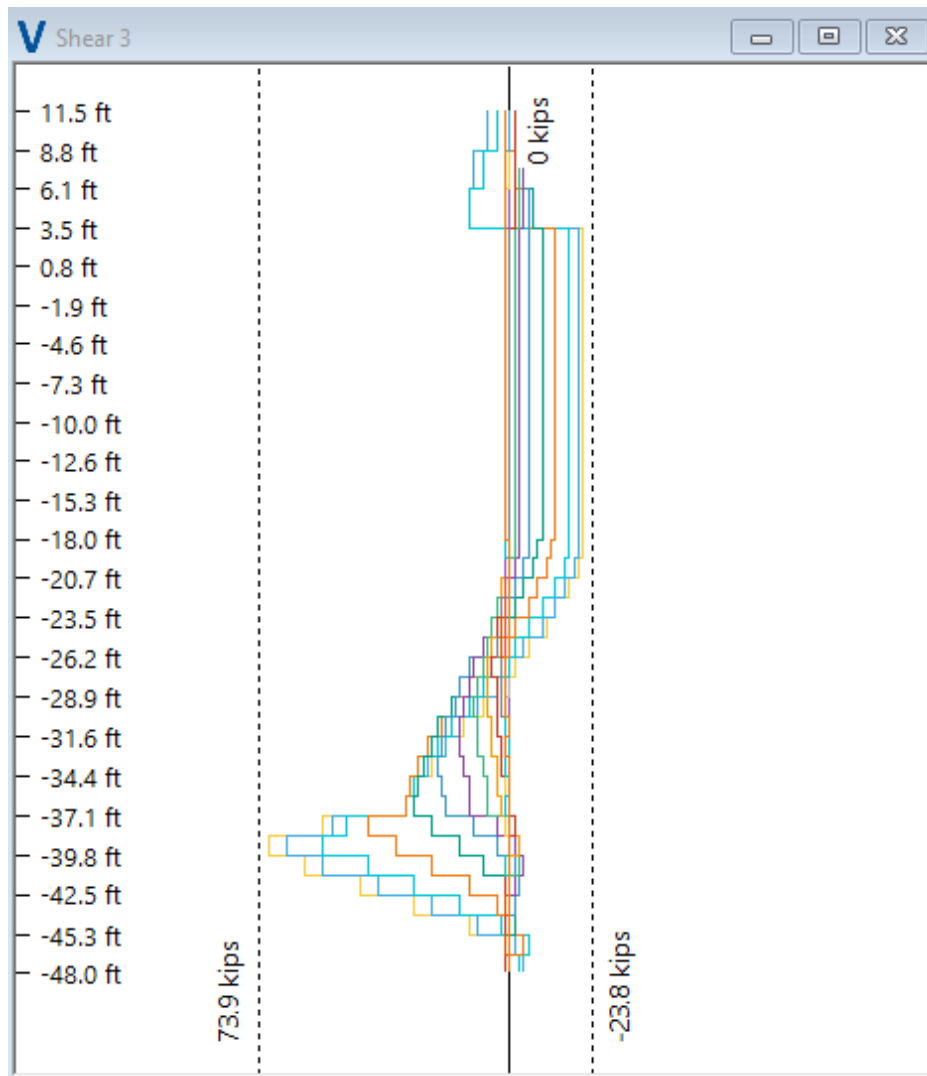

Figure 65: Max Pile Shear - Load Case 7 (Section 1 -Soil C2)

**Allowable Pile Shear Design Capacity after statistical reductions = 303.5 kip**  
**Actual of 73.9 kips <= Allowable of 303.5 kips (Acceptable)**

Wale Moment Capacity Check - Load Case 7 (Section 1- Soil C2)

Maximum wale moment (12x12 8F12) = 130 ft-kip (See Figure 66 below)

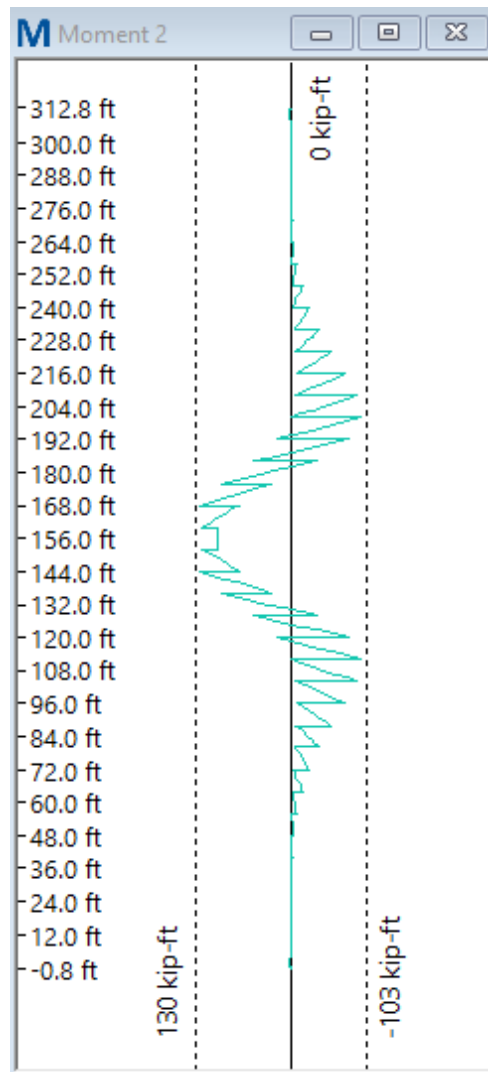

Figure 66: Max Wale Moment - Load Case 7 (Section 1-Soil C2)

**Allowable Wale Design Capacity after environment reductions = 283 ft-kip**  
**Actual of 130 ft-kip <= Allowable of 283 ft-kip (Acceptable)**

Pile Displacement Check - Load Case 7 (Section 1 – Soil C2)

See Figure 67 below.

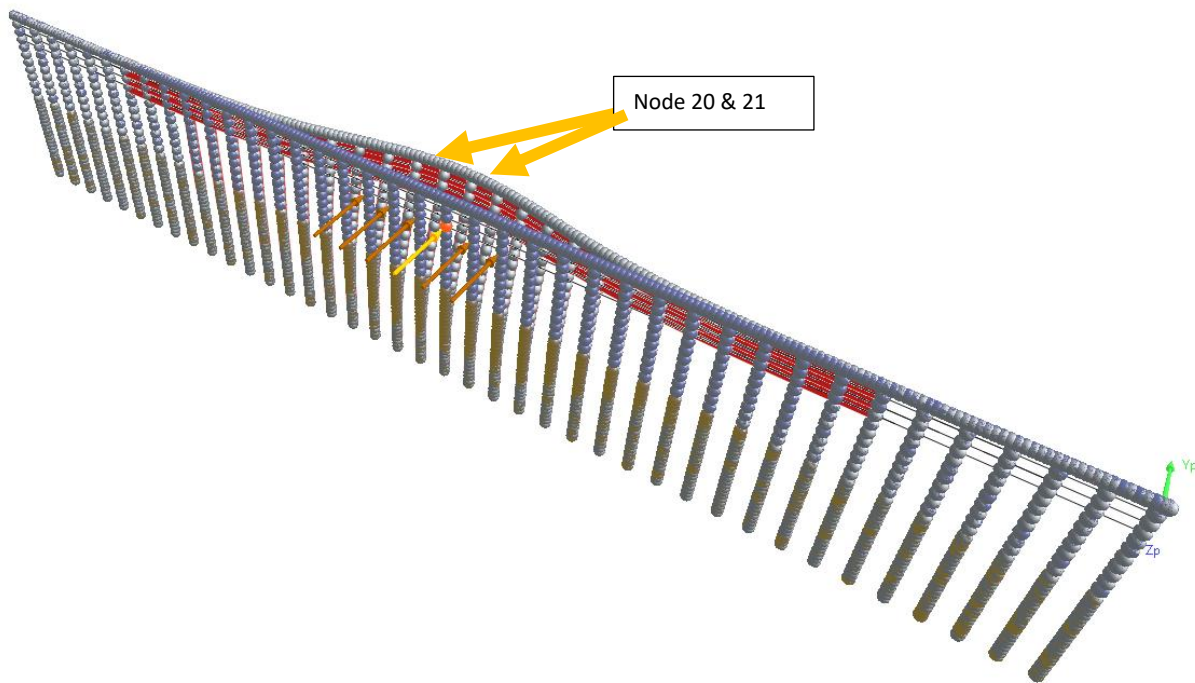

Figure 67: Displacement - Load Case 7 (Section 1-Soil C2)

**Maximum Pile displacement of system at back face is on node 20 & 21 with a displacement of 137.9 in.**

3.6.2 Load Case 8 – Section 2 Fender System – C3 Soil

The illustration of the nodes that are loaded are shown in Figure 68. Different iterations were performed modifying the applied load. Energy calculations (see Table 10) were performed until the vessel impact energy equal to or above 829 ft-kip was achieved.

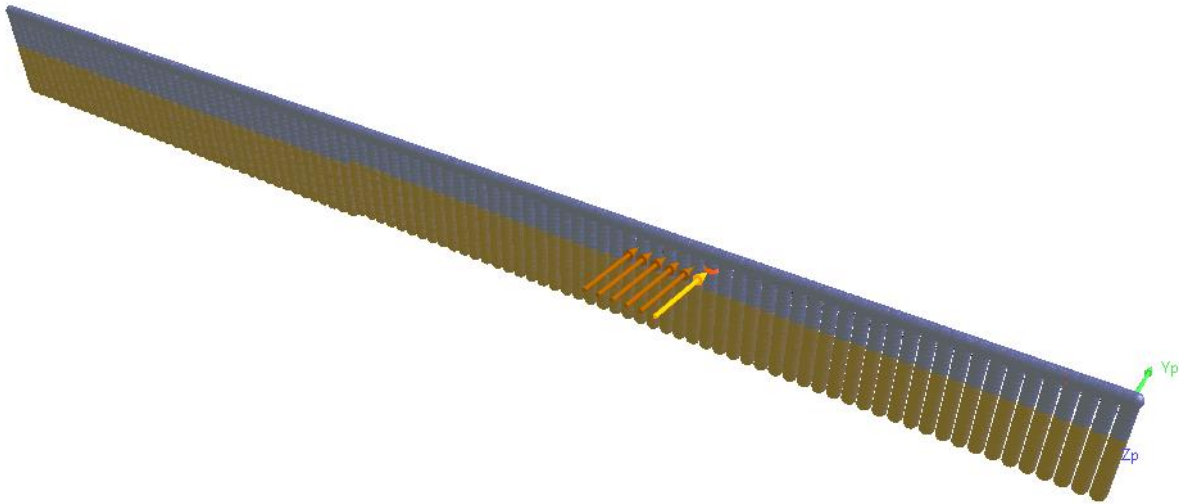

Figure 68: Layout – Load Case 8 (Section 2 – Soil C3)

Table 10: Energy Calculations - Load Case 8 (Section 2 – Soil C3)

Node	Load (kips)	Deflection (in)	Energy (ft-kips)
1334	48	61.11	122.22
1364	48	74.5	149.00
1394	48	81.6	163.20
1424	48	81.6	163.20
1454	48	74.5	149.00
1484	48	61.11	122.22
<b>Total Energy (ft-kip)</b>			<b>868.84</b>

EAC = 868.84 ft-kip > Emin = 829 ft-kip (Acceptable)

Pile Moment Capacity Check - Load Case 8 (Section 2 – Soil C3)

Maximum pile moment (18" Diam. x 3/4" WT pile) = 589 ft-kip (See Figure 69 below)

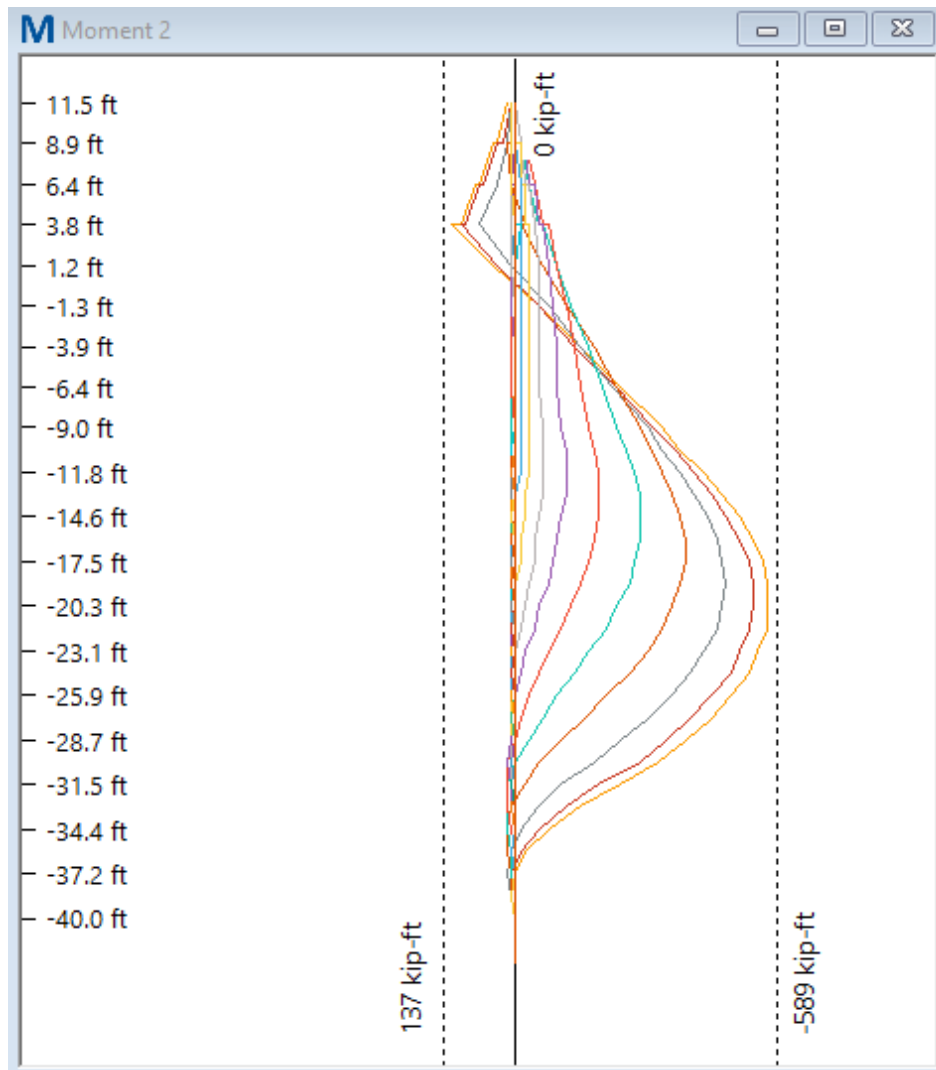

Figure 69: Max Pile Moment - Load Case 8 (Section 2-Soil C3)

**Allowable Pile Design Capacity after statistical reductions = 591 ft-kip**  
**Actual of 589 ft-kip <= Allowable of 591 ft-kip (Acceptable)**

Pile Shear Capacity Check - Load Case 8 (Section 2- Soil C3)

Maximum pile moment (18" Diam. x 3/4" WT pile) = 66 kips (See Figure 70 below)

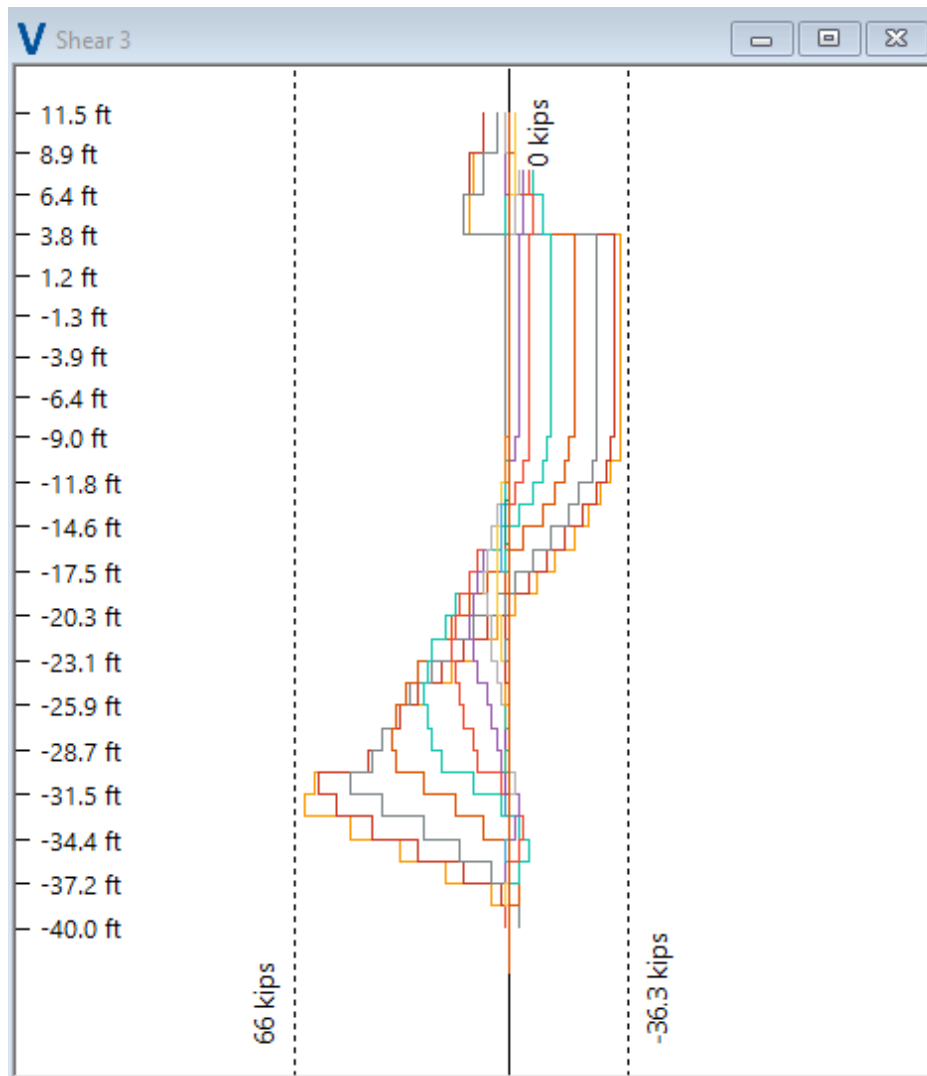

Figure 70: Max Pile Shear - Load Case 8 (Section 2 -Soil C3)

**Allowable Pile Shear Design Capacity after statistical reductions = 303.5 kip**  
**Actual of 66 kips <= Allowable of 303.5 kips (Acceptable)**

Wale Moment Capacity Check - Load Case 8 (Section 2- Soil C3)

Maximum wale moment (12x12 8F12) = 134 ft-kip (See Figure 71 below)

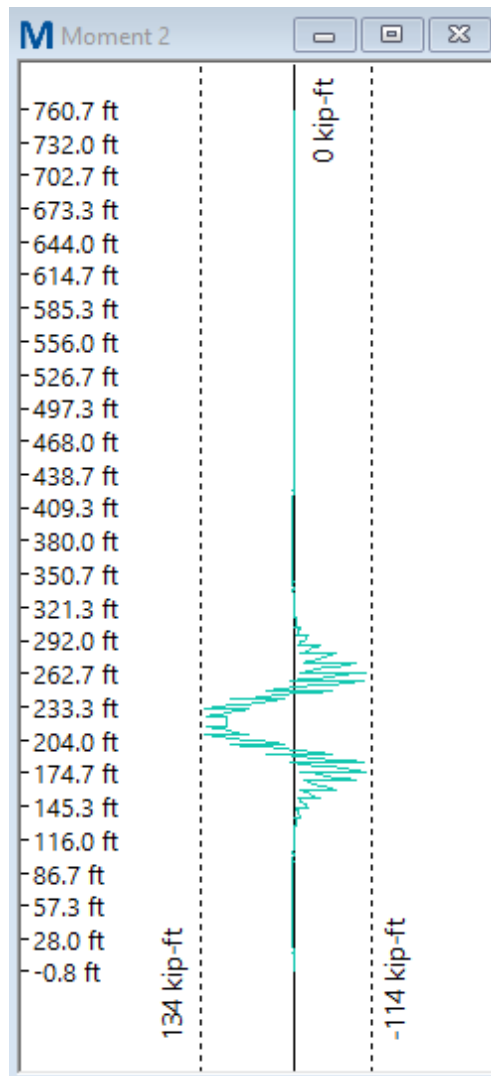

Figure 71: Max Wale Moment - Load Case 8 (Section 2-Soil C3)

**Allowable Wale Design Capacity after environment reductions = 283 ft-kip**  
**Actual of 134 ft-kip <= Allowable of 283 ft-kip (Acceptable)**

Pile Displacement Check - Load Case 8 (Section 2 – Soil C3)

See Figure 72 below.

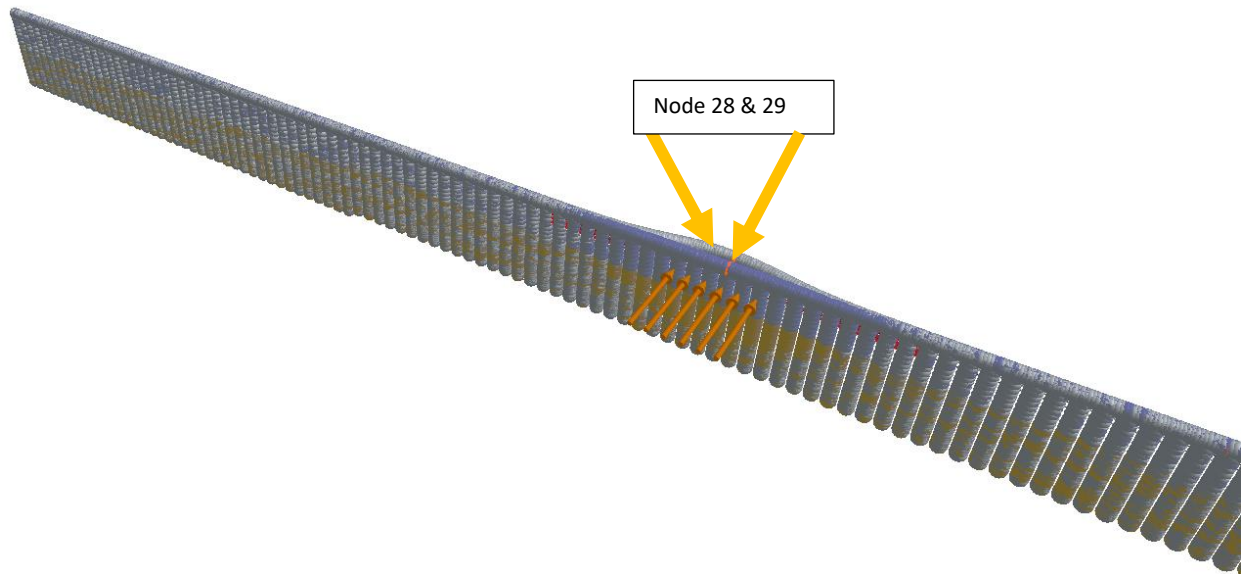

Figure 72: Displacement - Load Case 8 (Section 2-Soil C3)

**Maximum Pile displacement of system at back face is on node 28 & 29 with a displacement of 108.9 in.**

3.6.3 Load Case 9 – Section 2 Fender System – C4 Soil

The illustration of the nodes that are loaded are shown in Figure 73. Different iterations were performed modifying the applied load. Energy calculations (see Table 11) were performed until the vessel impact energy equal to or above 829 ft-kip was achieved.

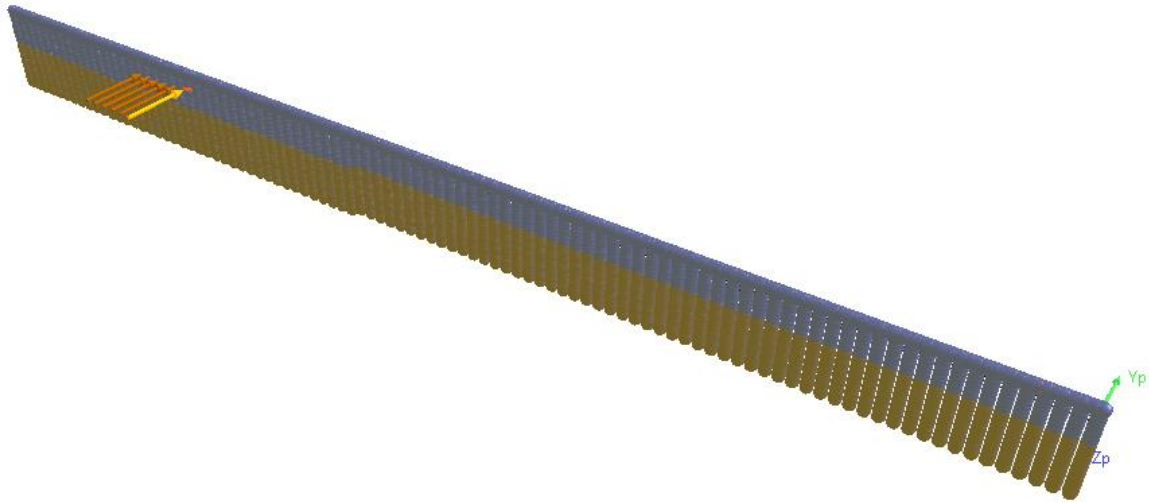

Figure 73: Layout – Load Case 9 (Section 2 – Soil C4)

Table 11: Energy Calculations - Load Case 9 (Section 2 – Soil C4)

Node	Load (kips)	Deflection (in)	Energy (ft-kips)
2774	44.5	68.2	126.45
2804	44.5	81.8	151.67
2834	44.5	89	165.02
2864	44.5	89	165.02
2894	44.5	81.8	151.67
2924	44.5	68.2	126.45
<b>Total Energy (ft-kip)</b>			<b>886.29</b>

EAC = 886.29 ft-kip > Emin = 829 ft-kip (Acceptable)

Pile Moment Capacity Check - Load Case 9 (Section 2 – Soil C4)

Maximum pile moment (18" Diam. x 3/4" WT pile) = 588 ft-kip (See Figure 74: Max Pile Moment - Load Case 9 (Section 2-Soil C4)Figure 74 below)

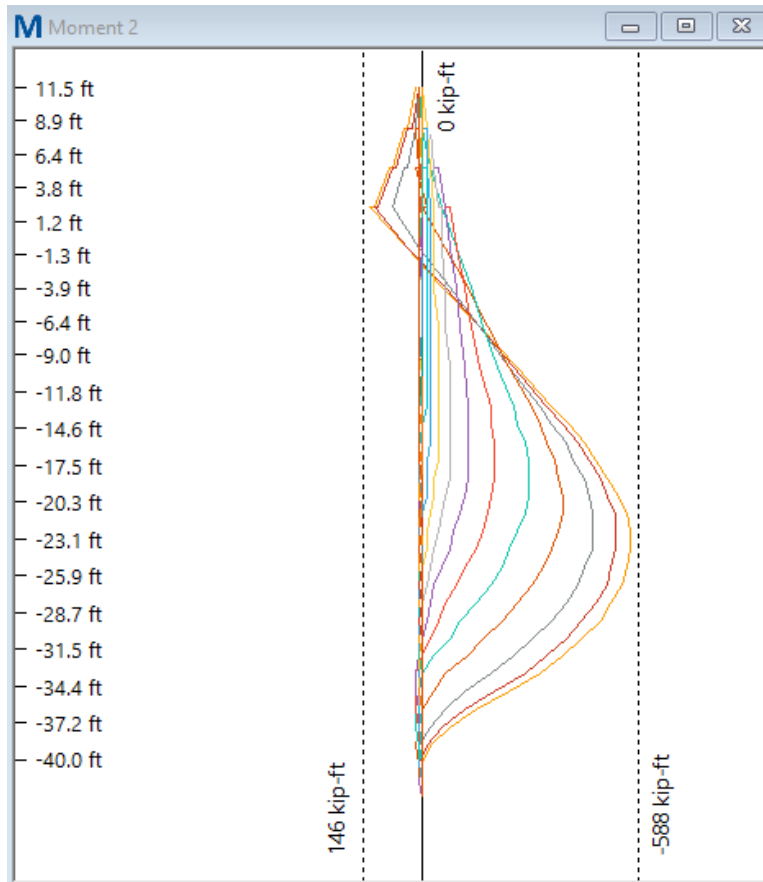

Figure 74: Max Pile Moment - Load Case 9 (Section 2-Soil C4)

**Allowable Pile Design Capacity after statistical reductions = 591 ft-kip**  
**Actual of 588 ft-kip <= Allowable of 591 ft-kip (Acceptable)**

Pile Shear Capacity Check - Load Case 9 (Section 2- Soil C4)

Maximum pile moment (18" Diam. x 3/4" WT pile) = 69.9 kips (See Figure 75 below)

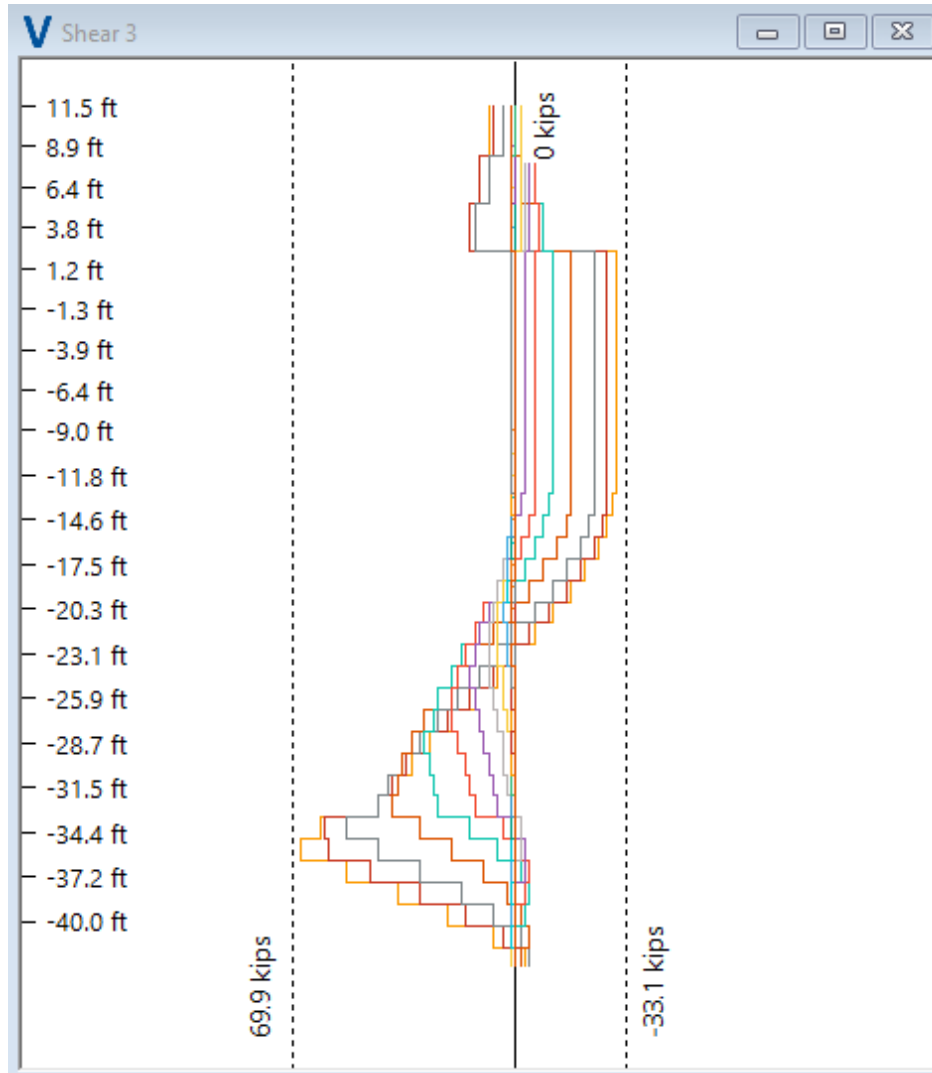

Figure 75: Max Pile Shear - Load Case 9 (Section 2 -Soil C4)

**Allowable Pile Shear Design Capacity after statistical reductions = 303.5 kip**

**Actual of 69.9 kips <= Allowable of 303.5 kips (Acceptable)**

Wale Moment Capacity Check - Load Case 9 (Section 2- Soil C4)

Maximum wale moment (12x12 8F12) = 134 ft-kip (See Figure 76 below)

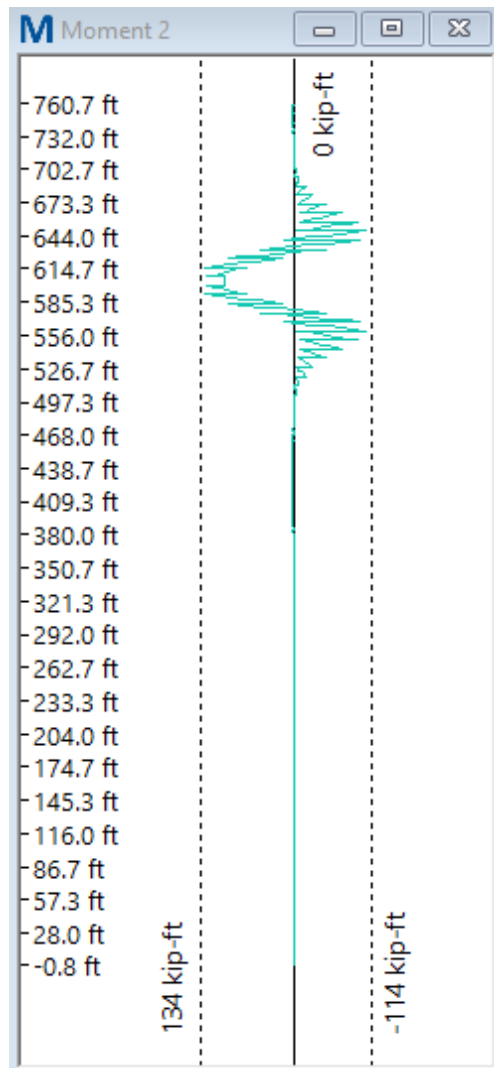

Figure 76: Max Wale Moment - Load Case 9 (Section 2-Soil C4)

**Allowable Wale Design Capacity after environment reductions = 283 ft-kip**  
**Actual of 134 ft-kip <= Allowable of 283 ft-kip (Acceptable)**

Pile Displacement Check - Load Case 9 (Section 2 – Soil C4)

See Figure 77 below.

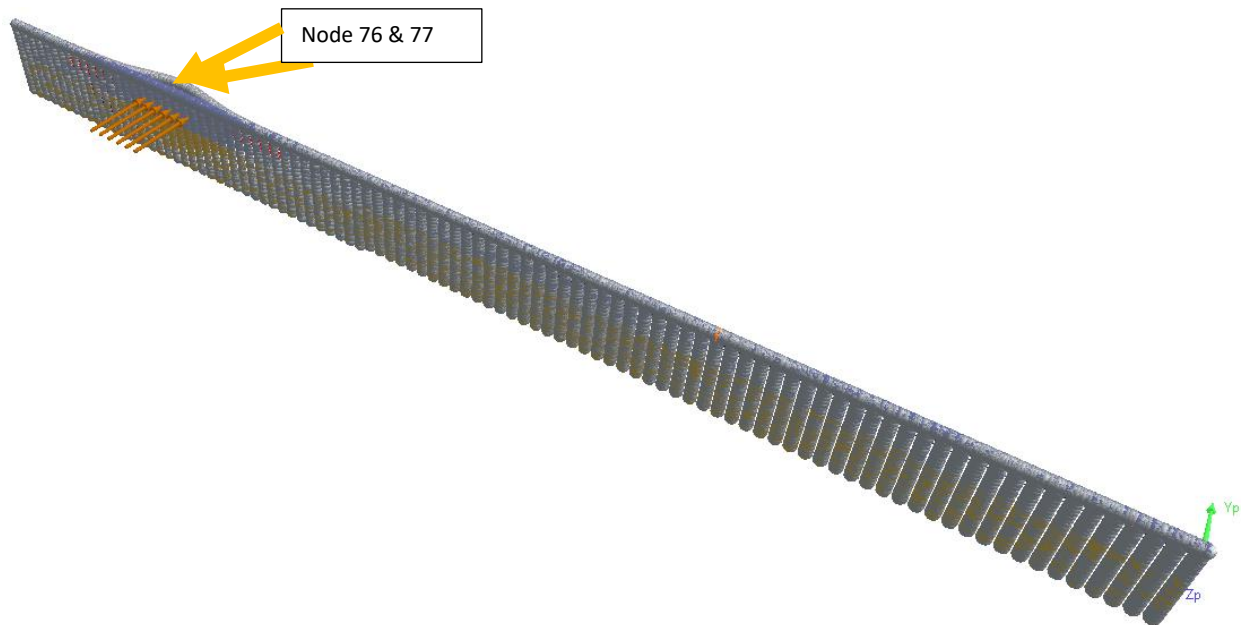

Figure 77: Displacement - Load Case 9 (Section 2-Soil C4)

**Maximum Pile displacement of system at back face is on node 76 & 77 with a displacement of 121.2 in.**

3.6.4 Load Case 10 – Section 3 Fender System – C4 Soil

The illustration of the nodes that are loaded are shown in Figure 78. Different iterations were performed modifying the applied load. Energy calculations (see Table 12) were performed until the vessel impact energy equal to or above 829 ft-kip was achieved.

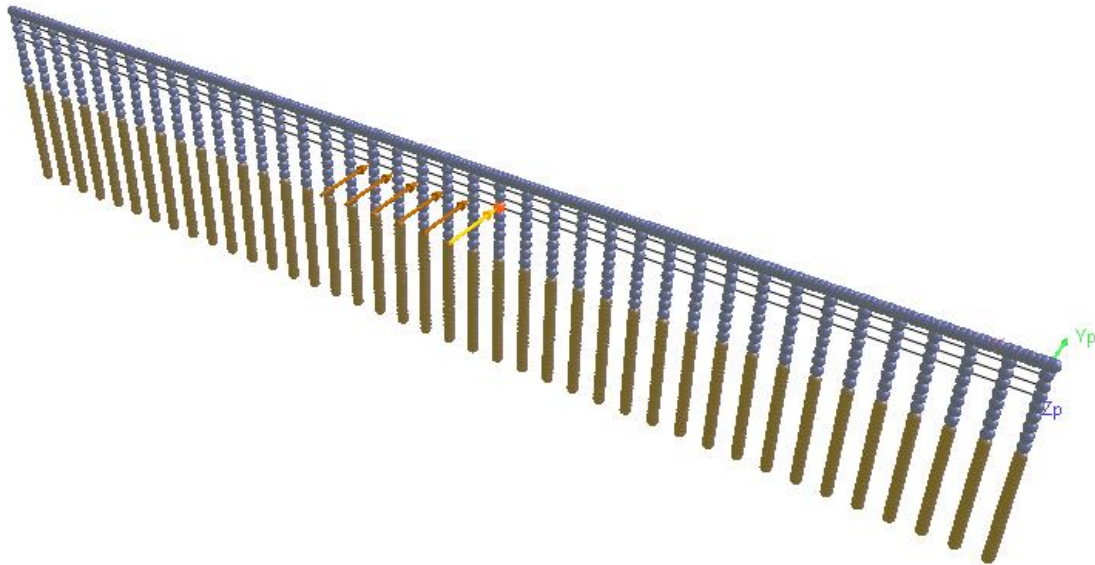

Figure 78: Layout – Load Case 10 (Section 3 – Soil C4)

Table 12: Energy Calculations - Load Case 10 (Section 3 – Soil C4)

Node	Load (kips)	Deflection (in)	Energy (ft-kips)
775	43	71.7	128.46
806	43	85.7	153.55
837	43	93	166.63
868	43	93	166.63
899	43	85.7	153.55
930	43	71.7	128.46
<b>Total Energy (ft-kip)</b>			<b>897.27</b>

EAC = 897.27 ft-kip > Emin = 829 ft-kip (Acceptable)

Pile Moment Capacity Check - Load Case 10 (Section 3 – Soil C4)

Maximum pile moment (18" Diam. x 3/4" WT pile) = 588 ft-kip (See Figure 79 below)

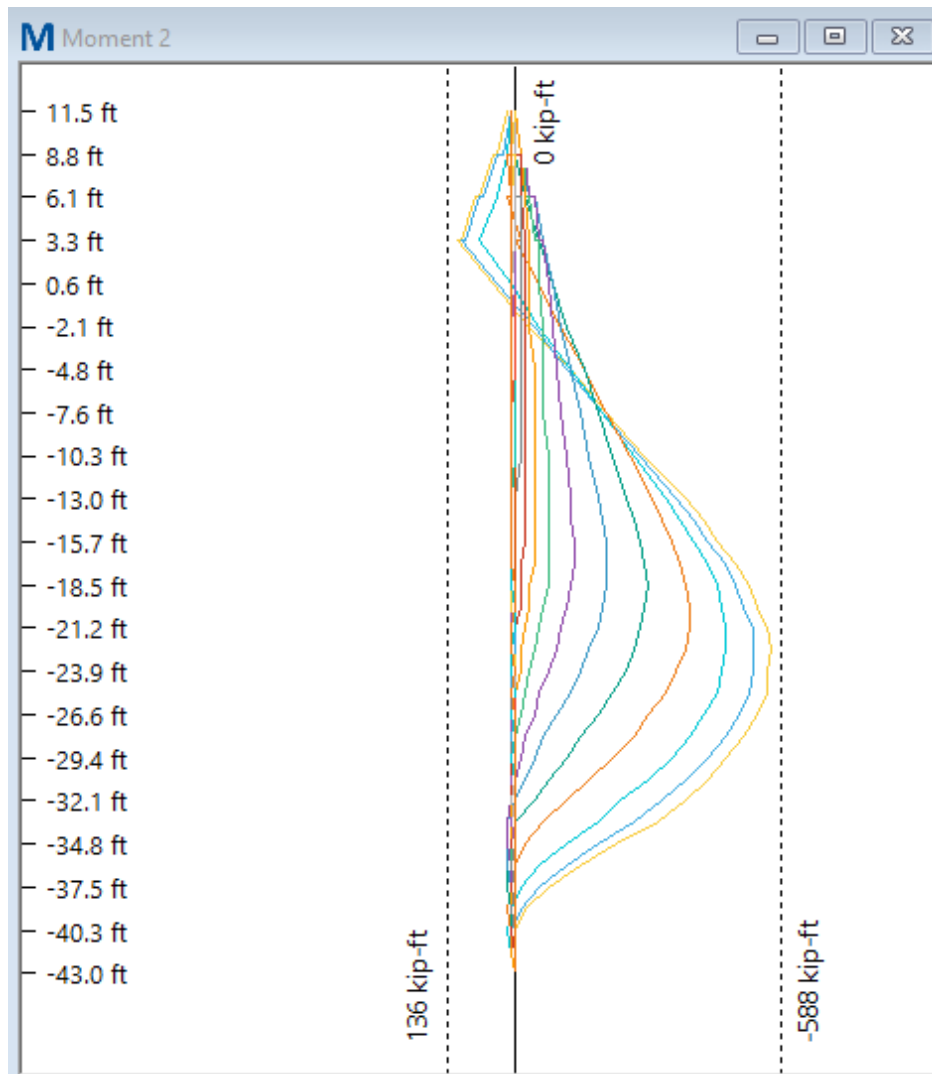

Figure 79: Max Pile Moment - Load Case 10 (Section 3-Soil C4)

**Allowable Pile Design Capacity after statistical reductions = 591 ft-kip**  
**Actual of 588 ft-kip <= Allowable of 591 ft-kip (Acceptable)**

Pile Shear Capacity Check - Load Case 10 (Section 3- Soil C4)

Maximum pile moment (18" Diam. x 3/4" WT pile) = 67.5 kips (See Figure 80 below)

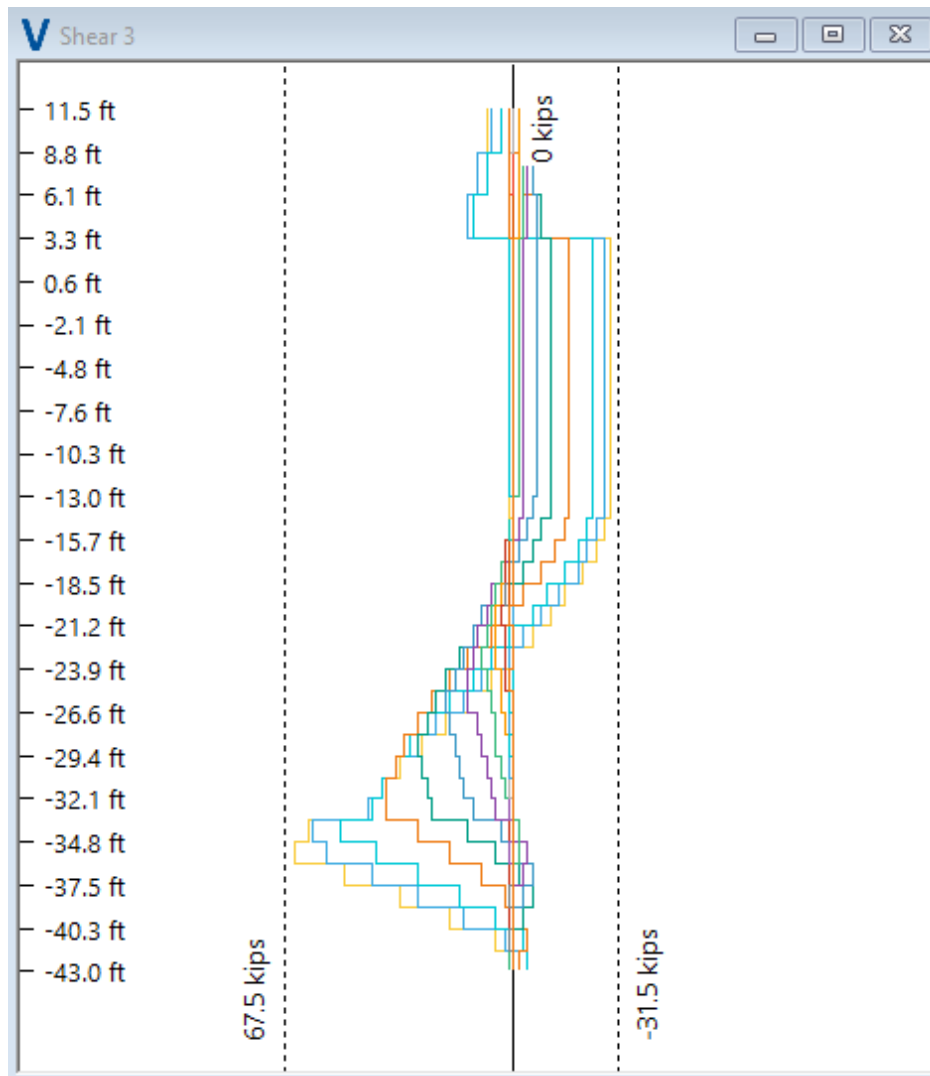

Figure 80: Max Pile Shear - Load Case 10 (Section 3 -Soil C4)

**Allowable Pile Shear Design Capacity after statistical reductions = 303.5 kip**  
**Actual of 67.5 kips <= Allowable of 303.5 kips (Acceptable)**

Wale Moment Capacity Check - Load Case 10 (Section 3- Soil C4)

Maximum wale moment (12x12 8F12) = 135 ft-kip (See Figure 81 below)

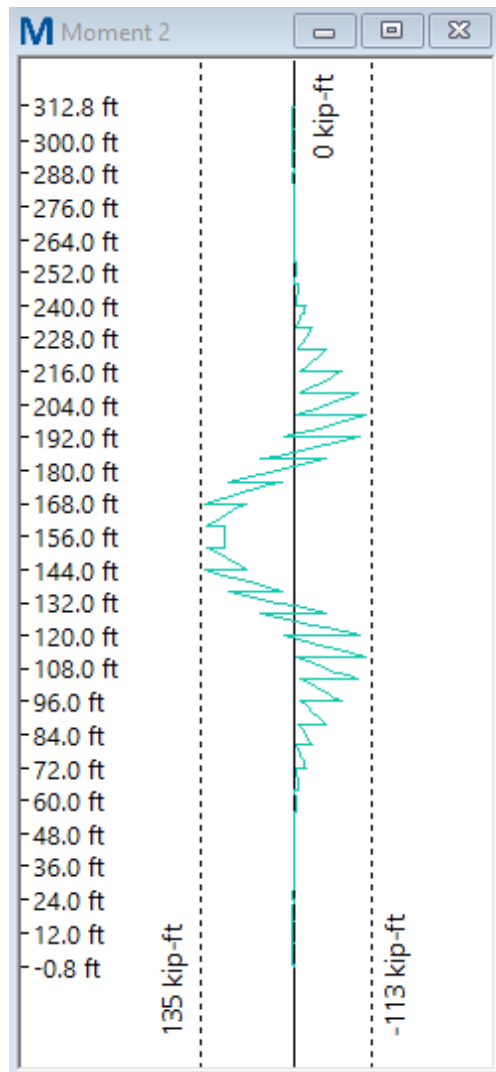

Figure 81: Max Wale Moment - Load Case 10 (Section 3-Soil C4)

**Allowable Wale Design Capacity after environment reductions = 283 ft-kip**  
**Actual of 135 ft-kip <= Allowable of 283 ft-kip (Acceptable)**

Pile Displacement Check - Load Case 10 (Section 3 – Soil C4)

See Figure 82 below.

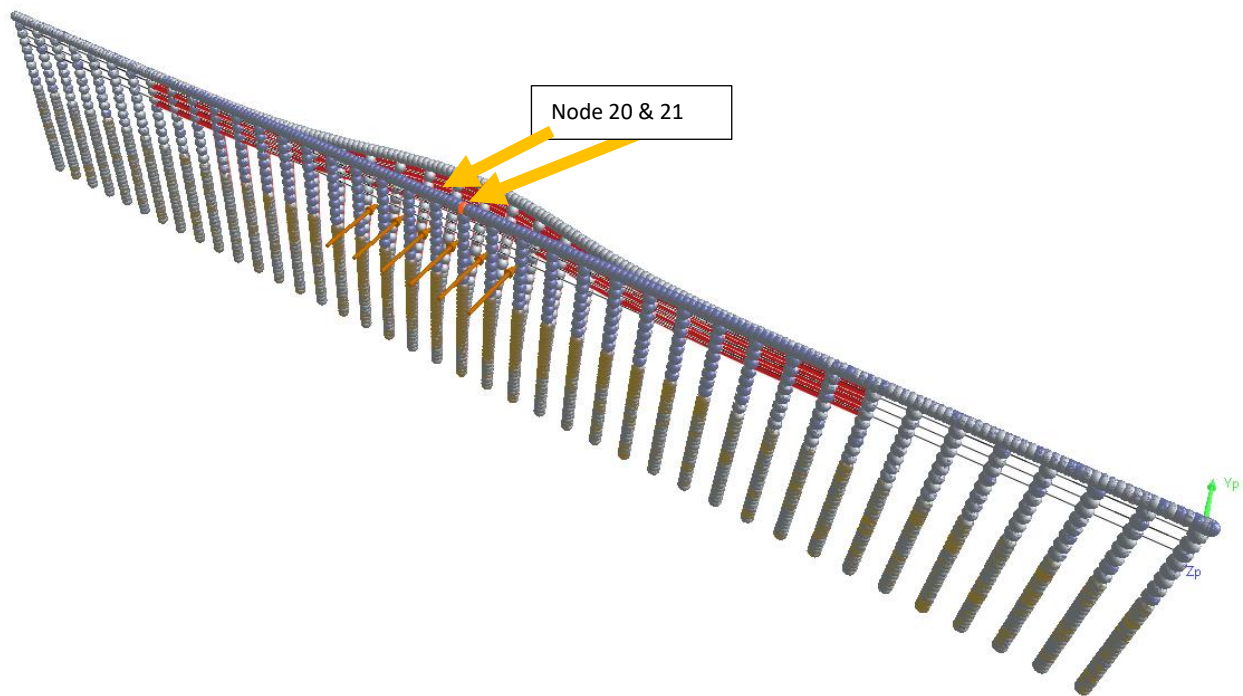

Figure 82: Displacement - Load Case 10 (Section 3-Soil C4)

**Maximum Pile displacement of system at back face is on node 20 & 21 with a displacement of 122.5 in.**

3.6.5 Load Case 11 – Section 4 Fender System – C4 Soil

The illustration of the nodes that are loaded are shown in Figure 83. Different iterations were performed modifying the applied load. Energy calculations (see Table 13) were performed until the vessel impact energy equal to or above 829 ft-kip was achieved.



Figure 83: Layout – Load Case 11 (Section 4 – Soil C4)

Table 13: Energy Calculations - Load Case 11 (Section 4 – Soil C4)

Node	Load (kips)	Deflection (in)	Energy (ft-kips)
1248	42	69	120.75
1279	42	82.6	144.55
1310	42	89.69	156.96
1341	42	89.69	156.96
1372	42	82.6	144.55
1403	42	69	120.75
<b>Total Energy (ft-kip)</b>			<b>844.52</b>

EAC = 844.52 ft-kip > Emin = 829 ft-kip (Acceptable)

Pile Moment Capacity Check - Load Case 11 (Section 4 – Soil C4)

Maximum pile moment (18" Diam. x 3/4" WT pile) = 573 ft-kip (See Figure 84 below)

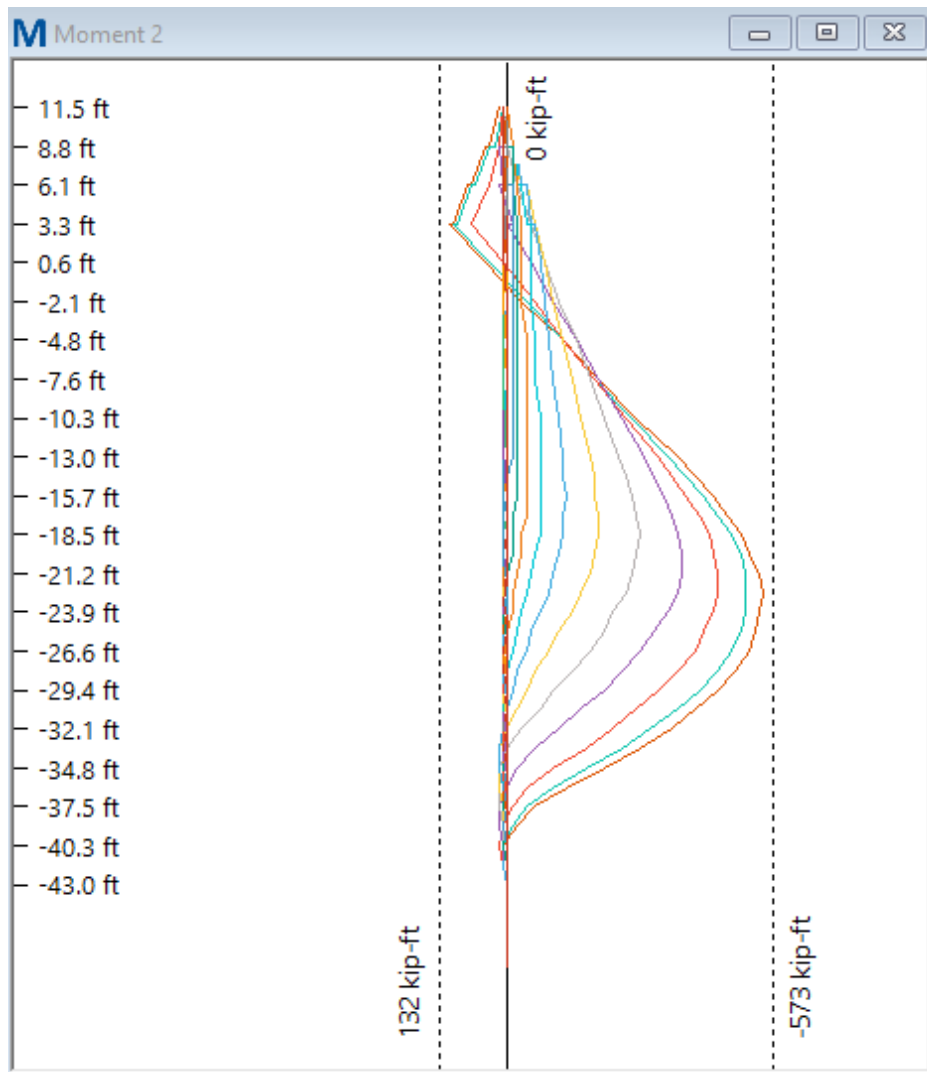

Figure 84: Max Pile Moment - Load Case 11 (Section 4-Soil C4)

**Allowable Pile Design Capacity after statistical reductions = 591 ft-kip**  
**Actual of 573 ft-kip <= Allowable of 591 ft-kip (Acceptable)**

Pile Shear Capacity Check - Load Case 11 (Section 4- Soil C4)

Maximum pile moment (18" Diam. x 3/4" WT pile) = 63.2 kips (See Figure 85 below)

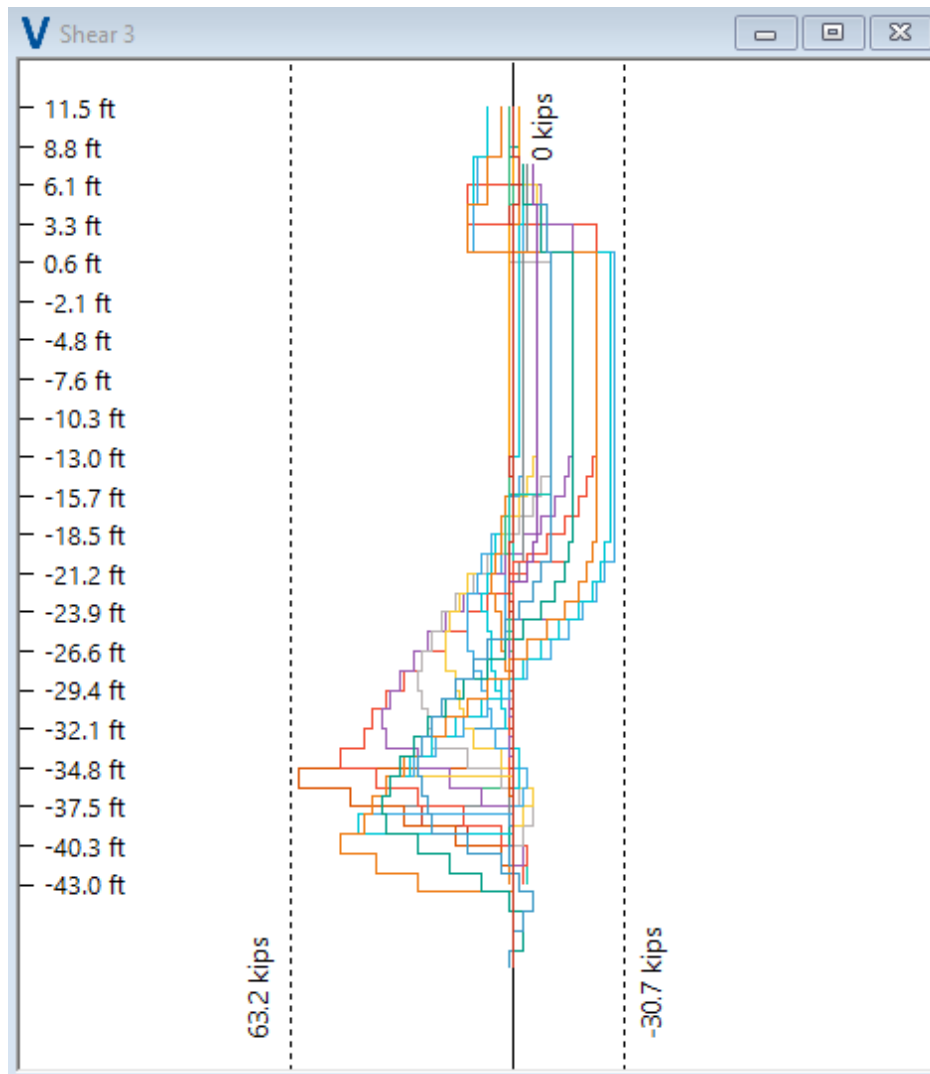

Figure 85: Max Pile Shear - Load Case 11 (Section 4 -Soil C4)

**Allowable Pile Shear Design Capacity after statistical reductions = 303.5 kip**  
**Actual of 63.2 kips <= Allowable of 303.5 kips (Acceptable)**

Wale Moment Capacity Check - Load Case 11 (Section 4- Soil C4)

Maximum wale moment (12x12 8F12) = 131 ft-kip (See Figure 86 below)

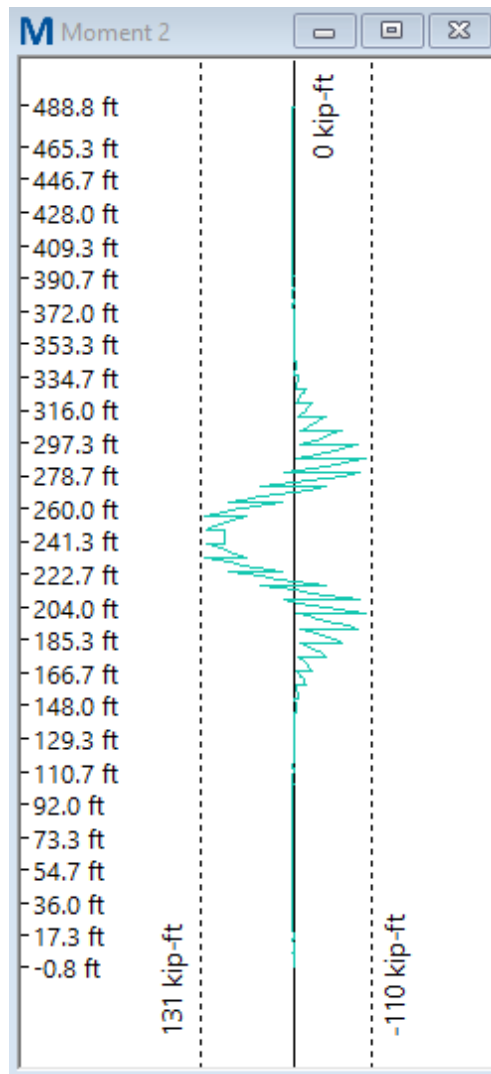

Figure 86: Max Wale Moment - Load Case 11 (Section 4-Soil C4)

**Allowable Wale Design Capacity after environment reductions = 283 ft-kip**  
**Actual of 131 ft-kip <= Allowable of 283 ft-kip (Acceptable)**

Pile Displacement Check - Load Case 11 (Section 4 – Soil C4)

See Figure 87 below.

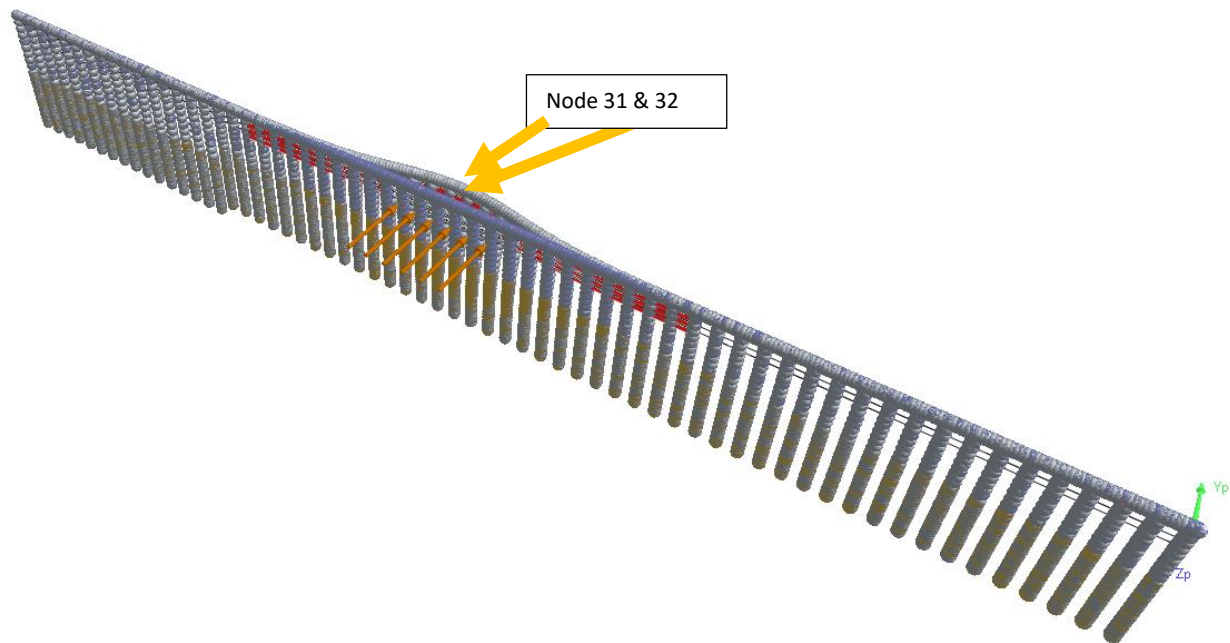

Figure 87: Displacement - Load Case 11 (Section 4-Soil C4)

**Maximum Pile displacement of system at back face is on node 31 & 32 with a displacement of 118.2 in.**

3.6.6 Load Case 12 – Section 4 Fender System – C5 Soil

The illustration of the nodes that are loaded are shown in Figure 88. Different iterations were performed modifying the applied load. Energy calculations (see Table 14) were performed until the vessel impact energy equal to or above 829 ft-kip was achieved.

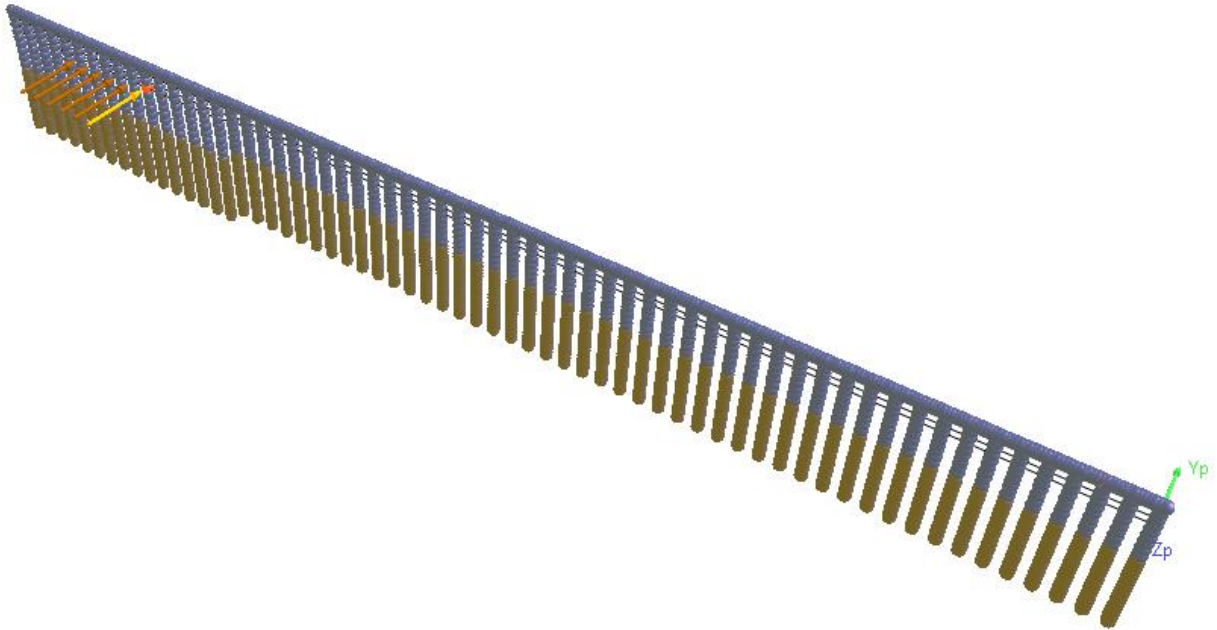

Figure 88: Layout – Load Case 12 (Section 4 – Soil C5)

Table 14: Energy Calculations - Load Case 12 (Section 4 – Soil C5)

Node	Load (kips)	Deflection (in)	Energy (ft-kips)
1961	38	79.37	125.67
1992	38	93	147.25
2023	38	100.4	158.97
2054	38	100.4	158.97
2085	38	93	147.25
2116	38	79.37	125.67
<b>Total Energy (ft-kip)</b>			<b>863.77</b>

EAC = 863.77 ft-kip > Emin = 829 ft-kip (Acceptable)

Pile Moment Capacity Check - Load Case 12 (Section 4 – Soil C5)

Maximum pile moment (18" Diam. x 3/4" WT pile) = 578 ft-kip (See Figure 89 below)

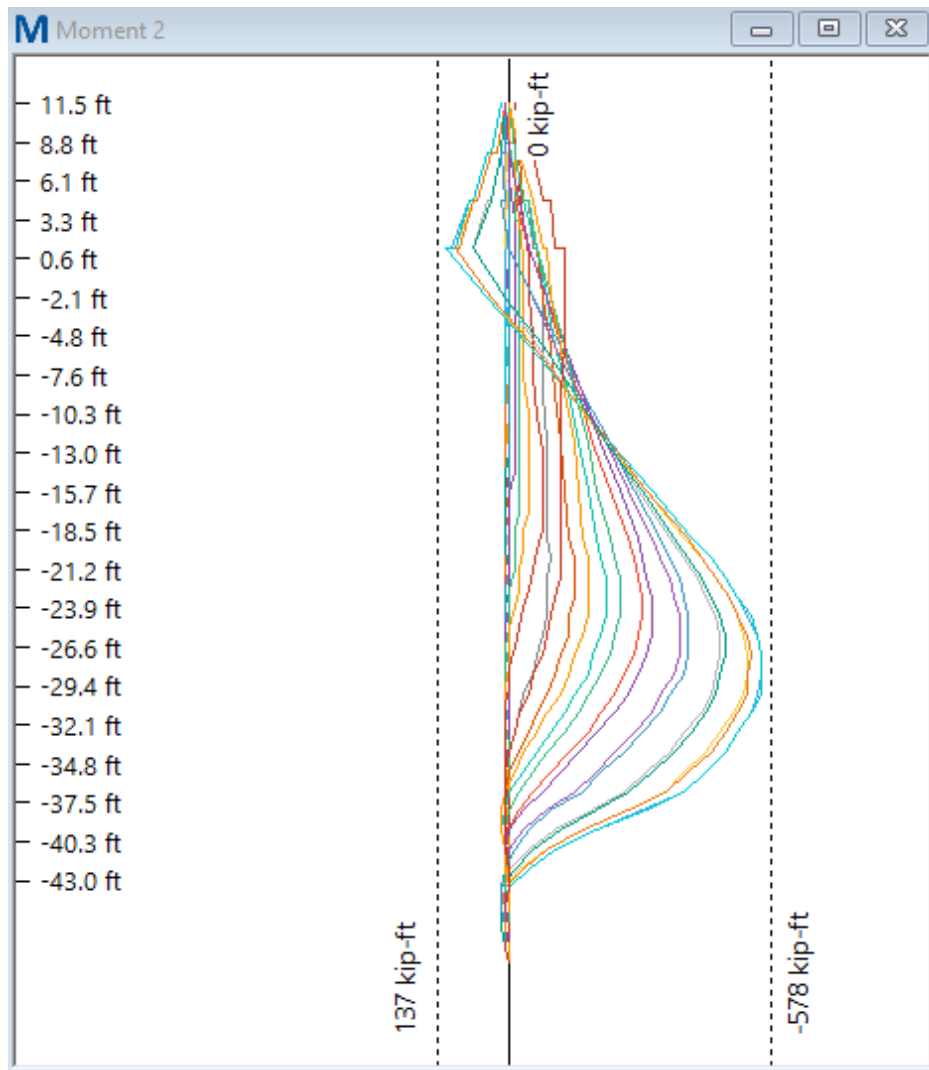

Figure 89: Max Pile Moment - Load Case 12 (Section 4-Soil C5)

**Allowable Pile Design Capacity after statistical reductions = 591 ft-kip**  
**Actual of 578 ft-kip <= Allowable of 591 ft-kip (Acceptable)**

Pile Shear Capacity Check - Load Case 12 (Section 4- Soil C5)

Maximum pile moment (18" Diam. x 3/4" WT pile) = 79.4 kips (See Figure 90 below)

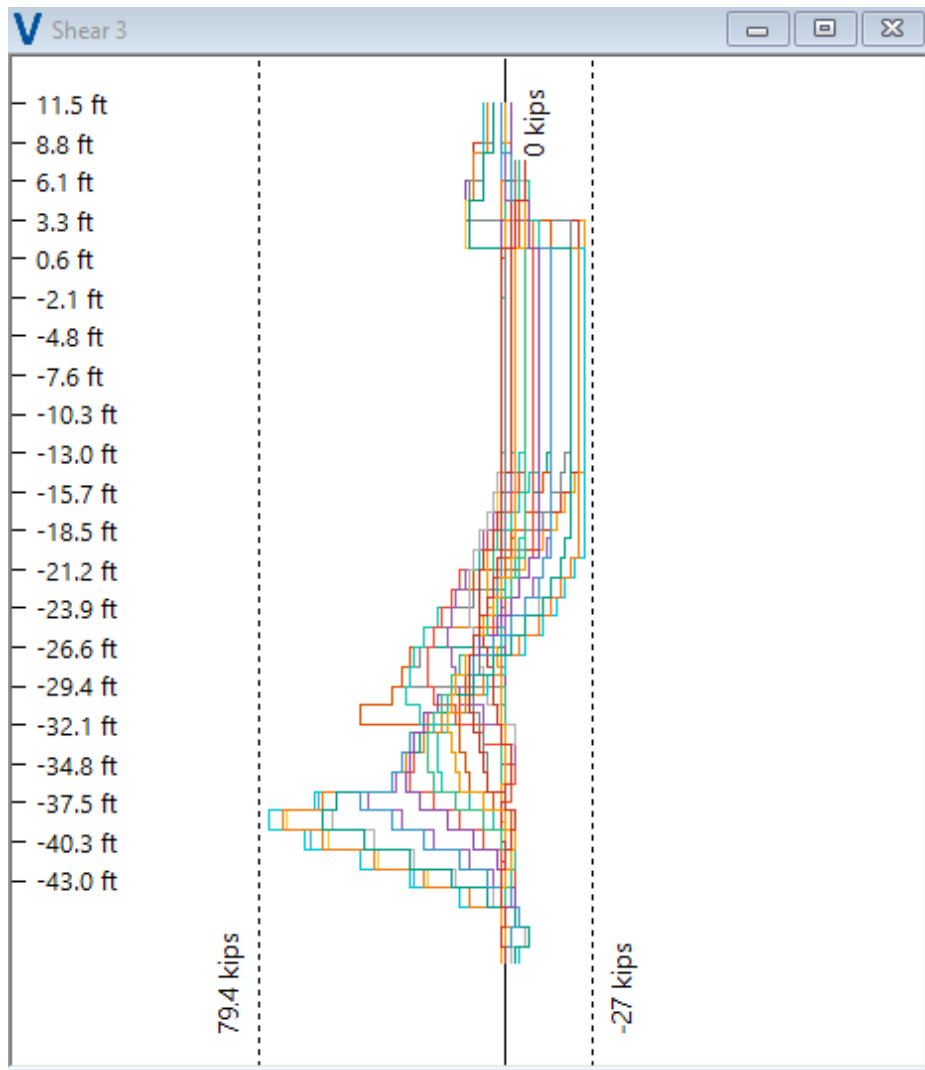

Figure 90: Max Pile Shear - Load Case 12 (Section 4 -Soil C5)

**Allowable Pile Shear Design Capacity after statistical reductions = 303.5 kip**  
**Actual of 79.4 kips <= Allowable of 303.5 kips (Acceptable)**

Wale Moment Capacity Check - Load Case 12 (Section 4- Soil C5)

Maximum wale moment (12x12 8F12) = 129 ft-kip (See Figure 91 below)

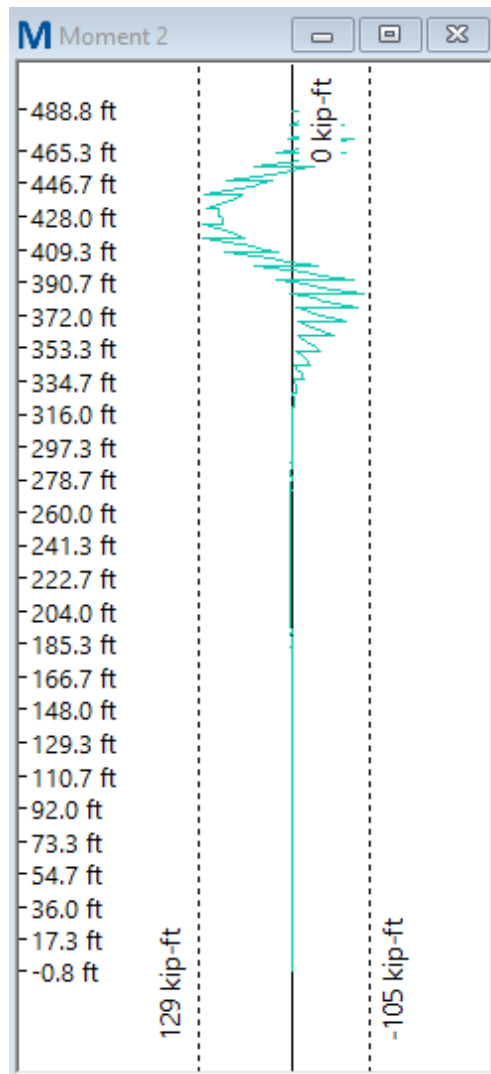

Figure 91: Max Wale Moment - Load Case 12 (Section 4-Soil C5)

**Allowable Wale Design Capacity after environment reductions = 283 ft-kip**  
**Actual of 129 ft-kip <= Allowable of 283 ft-kip (Acceptable)**

Pile Displacement Check - Load Case 12 (Section 4 – Soil C5)

See Figure 92 below.



Figure 92: Displacement - Load Case 12 (Section 4-Soil C5)

**Maximum Pile displacement of system at back face is on node 31 & 32 with a displacement of 136.7 in.**

## 4 Minimum Tip Analysis

Pile tip analysis in FB-MultiPier is done with a single cantilever pile model. The pile is loaded with a transverse load that generates the failure moment in the pile. Then the unstable embedment depth ( $E_0$ ) is determined by raising the pile tip elevation until pile deflections become unreasonable or the program does not converge on a solution. Once the unstable depth is identified the pile is lengthened 1' at a time until a reaction moment occurs at the bottom of the pile allowing for an installation depth that will cause the pile to fail before the soil.

### 4.1 Tip Analysis by Boring Location

#### 4.1.1 18" DIAM. x 3/4" WT PILE – C2 Soil

At pile length 54 ft (embedment of  $E_0=24$  ft), the software no longer finds a solution (soil fails). See Figure 93, this indicates the elevation at which the pile will tip over before it fails. Increasing the pile length to 60 ft created a reaction moment at the bottom of the pile.

Figure 94 below shows the moment down the elevation of the pile to show the pile at its failure moment based on the controlling minimum tip.

Supplied pile length for piles in soil C2 to be 61 ft (1' for damage + 12' above the waterline + 48' below the waterline)

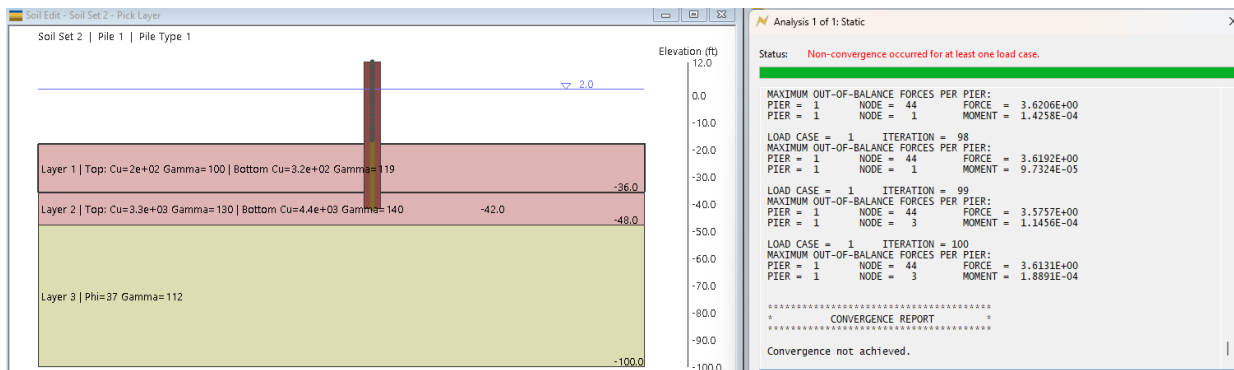

Figure 93: Non-Convergence Pile Depth (Soil C2)

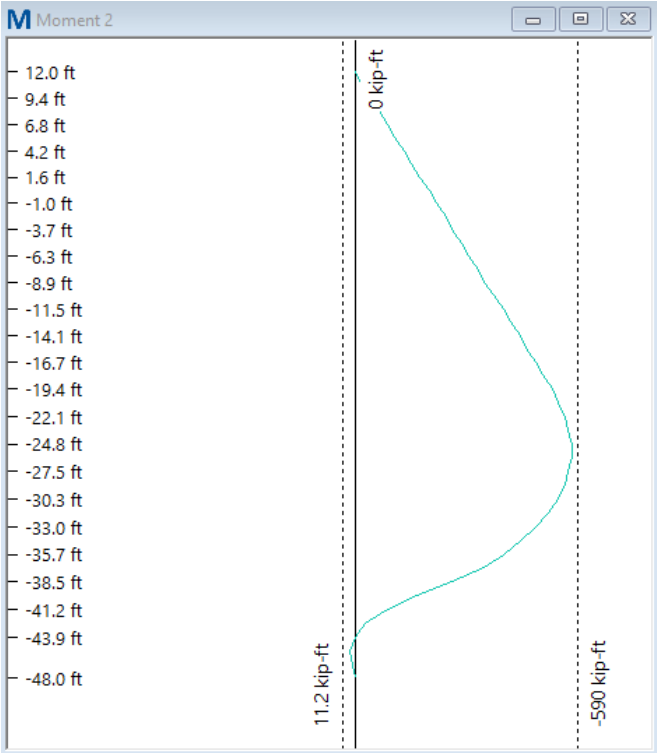

Figure 94: Moment Diagram Down the Elevation (Soil C2)

**Bending moment from tip analysis of 590 ft-kip is close to the design ultimate capacity of the pile (18" x 3/4") of 591 ft-kip.**

4.1.2 18” DIAM. x 3/4” WT PILE – C3 Soil

At pile length 46 ft (embedment of  $E_0=25$  ft), the software no longer finds a solution (soil fails). See Figure 95, this indicates the elevation at which the pile will tip over before it fails. Increasing the pile length to 52 ft created a reaction moment at the bottom of the pile.

Figure 96 below shows the moment down the elevation of the pile to show the pile at its failure moment based on the controlling minimum tip.

Supplied pile length for piles in soil C3 to be 53 ft (1’ for damage + 12’ above the waterline + 40’ below the waterline)

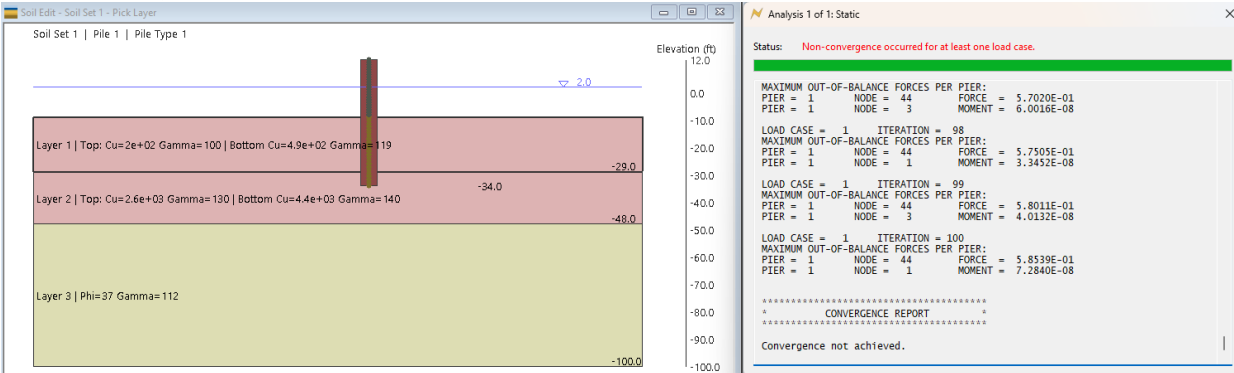

Figure 95: Non-Convergence Pile Depth (Soil C3)

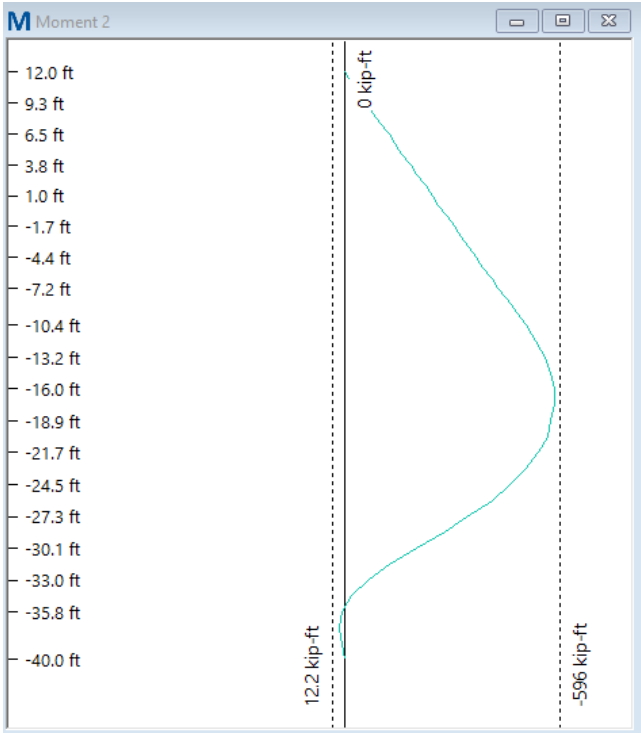

Figure 96: Moment Diagram Down the Elevation (Soil C3)

Bending moment from tip analysis of 596 ft-kip is close to the design ultimate capacity of the pile (18” x 3/4”) of 591 ft-kip

4.1.3 18” DIAM. x ¾” WT PILE – C4 Soil

At pile length 49 ft (embedment of  $E_0=24$  ft), the software no longer finds a solution (soil fails). See Figure 97, this indicates the elevation at which the pile will tip over before it fails. Increasing the pile length to 55 ft created a reaction moment at the bottom of the pile.

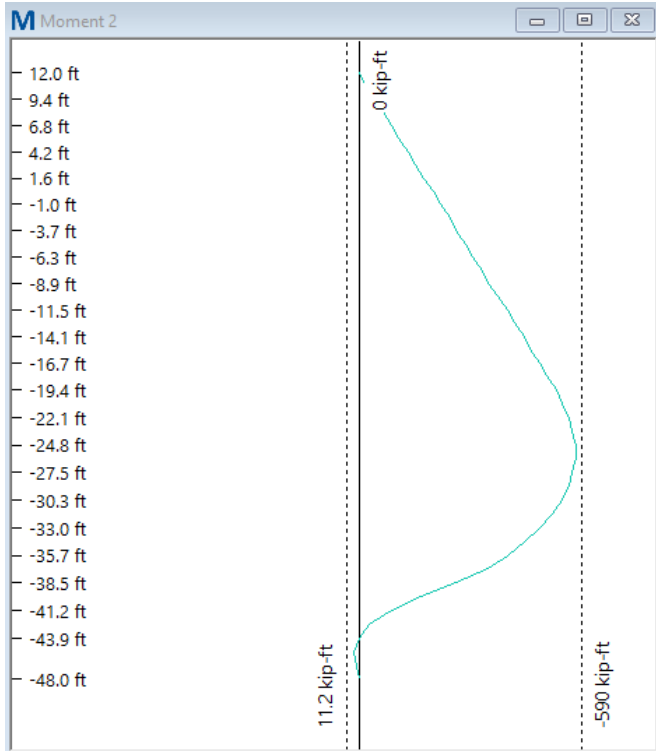

Figure 94 below shows the moment down the elevation of the pile to show the pile at its failure moment based on the controlling minimum tip.

Supplied pile length for piles in soil C4 to be 56 ft (1’ for damage + 12’ above the waterline + 43’ below the waterline)

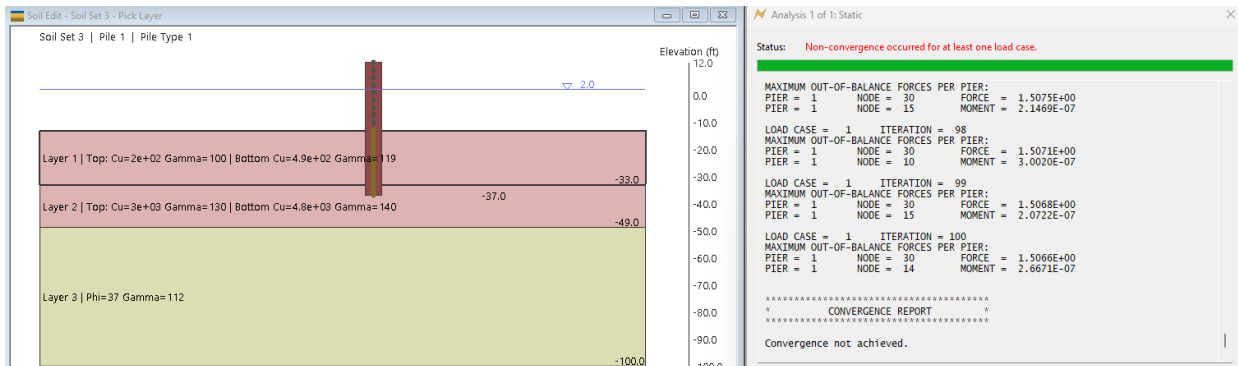

Figure 97: Non-Convergence Pile Depth (Soil C4)

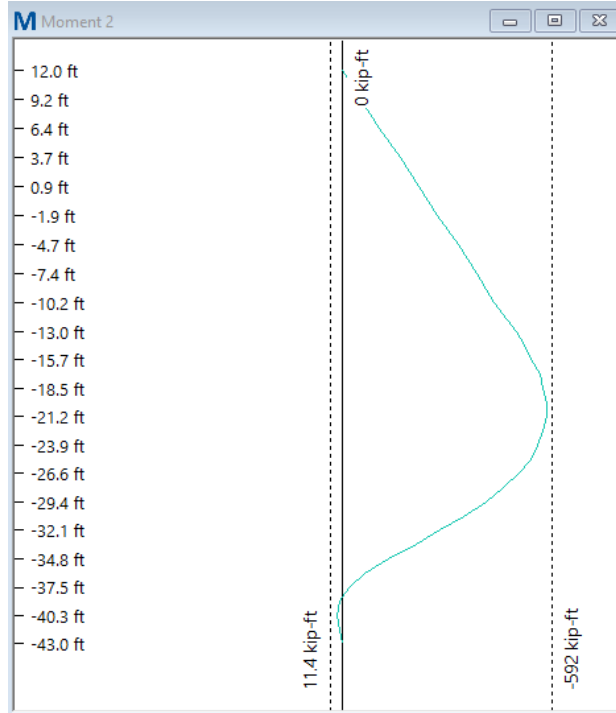

Figure 98: Moment Diagram Down the Elevation (Soil C4)

**Bending moment from tip analysis of 592 ft-kip is close to the design ultimate capacity of the pile (18" x 3/4") of 591 ft-kip.**

4.1.4 18" DIAM. x 3/4" WT PILE – C5 Soil

At pile length 53 ft (embedment of  $E_0=22$  ft), the software no longer finds a solution (soil fails). See Figure 99, this indicates the elevation at which the pile will tip over before it fails. Increasing the pile length to 59 ft created a reaction moment at the bottom of the pile.

Figure 100 below shows the moment down the elevation of the pile to show the pile at its failure moment based on the controlling minimum tip.

Supplied pile length for piles in soil C4 to be 60 ft (1' for damage + 12' above the waterline + 47' below the waterline)

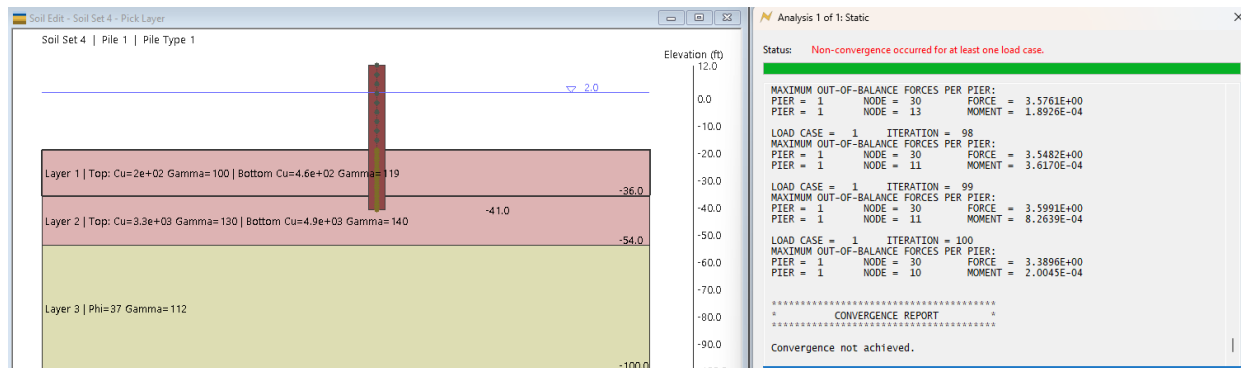

Figure 99: Non-Convergence Pile Depth (Soil C5)

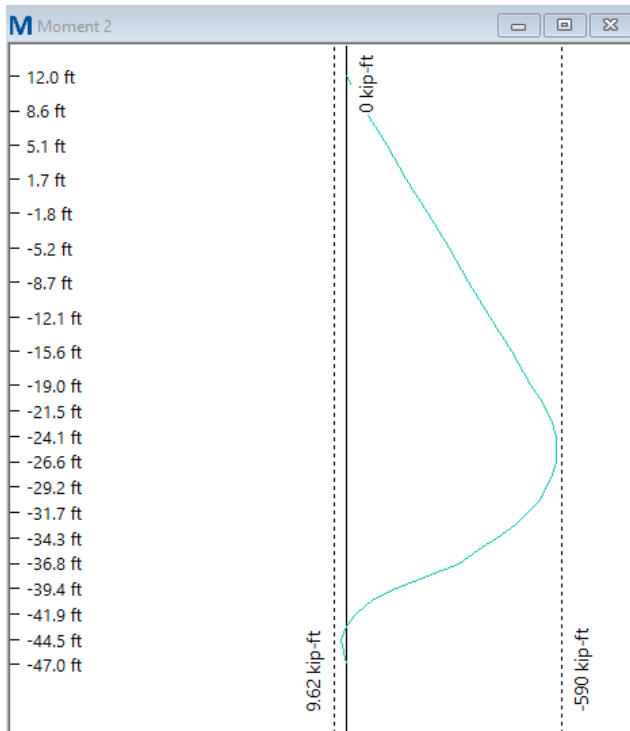

Figure 100: Moment Diagram Down the Elevation (Soil C5)

**Bending moment from tip analysis of 590 ft-kip is close to the design ultimate capacity of the pile (18" x 3/4") of 591 ft-kip**

## 5 FRP Splice Plate Calculations

Based on the calculations below the FRP splice plate thickness required is 3/4" thick and the ASTM A193 B8M hardware required is 1.25" diameter.

For the bolt capacity calculations, it is assumed that 4 of the threaded rods equally divide the impact loading across the splice. The HDPE plastic in the plastic lumber wales is ductile and will start to deform before the shear capacity of the threaded rod is reached. The design of these spliced members is to carry the full moment capacity of the wale through the splice, but there will be damage to the plastic lumber wale at that magnitude of impact loading.

### Splice Connection Threaded Rod Checks

$d := 1.25 \text{ in}$	Diameter of ASTM A193 B8M 316ss bolt
$f_u := 75 \text{ ksi}$	Minimum ultimate tensile stress of ASTM A193 B8M 316ss bolt
$\tau_u := f_u \cdot 0.6 = 45 \text{ ksi}$	Ultimate shear capacity of ASTM A193 B8M 316ss bolt
$a_b := \left(\frac{d}{2}\right)^2 \pi = 1.23 \text{ in}^2$	Cross sectional area of ASTM A193 B8M 316ss bolt
$r_n := a_b \cdot \tau_u = 55.2 \text{ kip}$	Ultimate shear capacity of ASTM A193 B8M 316ss bolt
$M_{w.max} := 283 \text{ ft} \cdot \text{kip}$	Ultimate moment capacity of 12x12 8F12 wale section
$l := 96 \text{ in}$	Span between supports of 12x12 8F12 wale section
$P_{moment} := \frac{(4 \cdot M_{w.max})}{l} = 141.5 \text{ kip}$	Mid span load to fail 12x12 8F12 wale section in bending
$P_{applied} := \frac{P_{moment}}{2} = 70.75 \text{ kip}$	Shear load applied to bolts in double shear
$\Omega_{bolts} := \frac{r_n \cdot 4}{P_{applied}} = 3.1$	Safety factor on bolt failure >1 means the wale fails first ACCEPTABLE

### Splice Connection FRP Plate Checks

$h := 10.75 \text{ in}$  Height of FRP splice plate  
 $t := 0.75 \text{ in}$  Thickness of FRP splice plate  
 $f_u := 65.7 \text{ ksi}$  Ultimate in plane flexural strength of FRP splice plate

$$M_{p.ult} := \left( \frac{1}{6} \cdot t \cdot h^2 \right) \cdot f_u = 79.1 \text{ ft} \cdot \text{kip}$$

Ultimate moment capacity of each FRP splice plate

$s := 24 \text{ in}$  Center to center spacing of FRP splice plate bolt groups. Based on FEA analysis this is a good approximation of the span for simple analysis.

$$M_{p.ser} := \frac{(P_{moment} \cdot s)}{4} \cdot \frac{1}{2} = 35.4 \text{ ft} \cdot \text{kip}$$

Actual moment loading per FRP splice plate

$$\Omega_{frp} := \frac{M_{p.ult}}{M_{p.ser}} = 2.236$$

Safety factor on FRP splice plate failure >1 means the wale fails first ACCEPTABLE

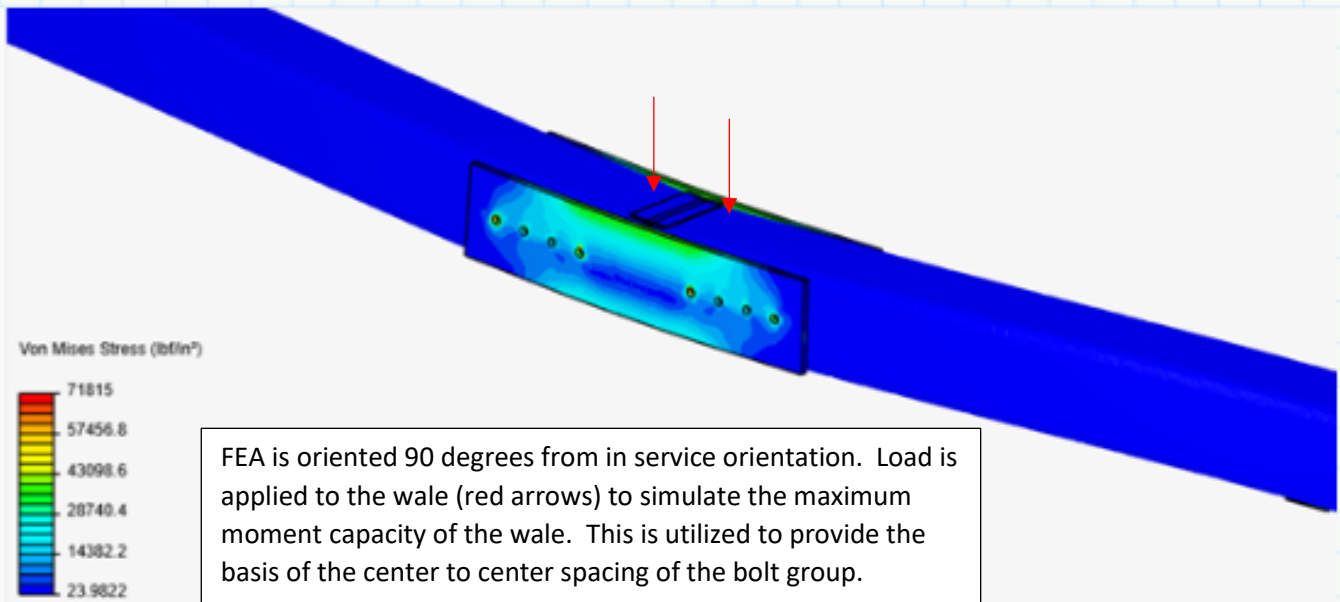

The ultimate pin bearing capacity of the FRP splice plate exceeds the shear capacity of the 316ss threaded rod.

$P_{bearing} := 60.45 \text{ ksi}$   
 $U_{pin.bearing} := P_{bearing} \cdot d \cdot t = 56.7 \text{ kip}$   
 $r_n = 55.2 \text{ kip}$

$U_{pin.bearing} > r_n$   
 Greater than the ultimate shear capacity of threaded rod. ACCEPTABLE.

## 6 Material Maintenance

The 18" OD FRP Pipe Piles and 12"x12" Fiberglass Reinforced Plastic Lumber (FRPL) Wales are expected to offer a 50+ year maintenance-free service life. Both products are very durable and designed for long term exposure in the aggressive, marine environment. The FRP Pipe Piles have been in service for 20+ years while the FRPL Wales have been in service for 30+ years on hundreds of fendering projects throughout the USA and internationally. Neither the FRP Pipe Piles, nor the FRPL Wales require any periodic maintenance to preserve the structural integrity of the members.

The recommended repair procedure provided in appendix D for the wales states the following:  
"SeaPile & SeaTimber are incredibly durable. There is no need to patch or repair abrasions, cuts or grooves for any other reason than aesthetics."

# Appendix A



For additional information about CPI composite piling products, or to learn how to lower your costs while increasing performance, contact a technical representative at 888-CPI-PULL (274-7855), or visit our website at [www.creativepultrusions.com](http://www.creativepultrusions.com).

214 Industrial Lane, Alum Bank, PA 15521  
Phone 814.839.4186 • Fax 814.839.4276 • Toll Free 888.CPI.PULL  
[www.creativepultrusions.com](http://www.creativepultrusions.com)

PRODUCT BROCHURE  
**SUPERPILE®**  
FIBERGLASS REINFORCED POLYMER (FRP) PIPE PILES



PLEASE SCAN WITH PHONE

©2014 Creative Pultrusions Printed in the USA CPM234-1213.1C  
DLR: August 11, 2015

Creative Pultrusions, Inc. reserves the right to edit and modify literature, please consult the web site for the most current version of this document.



## PROVIDING LEADERSHIP IN FRP PIPE PILE TECHNOLOGY

### CPI PIPE PILES

The SUPERPILE® product line was developed based on what owners, end users, engineers and contractors value in a pipe pile.

Creative Pultrusions, Inc. (CPI) is the world leader in pultrusion manufacturing. Our commitment to continuous process and product improvement has transformed CPI into a world-renowned pultruder specializing in custom profiles while utilizing high-performance resins and our proprietary high-pressure injection pultrusion technology.

As the world's most innovative leader in the FRP pultrusion industry, over the last two decades, we've developed structural systems that out perform and outlast structures built with traditional materials of construction. CPI has continued to build upon their reputation by introducing a pipe pile product line known as SUPERPILE®. Developed to provide superior performance in harsh marine environments, SUPERPILE® has been developed to drive faster and last longer than traditional piles.

### WHAT IS PULTRUSION?

Pultrusion is a continuous manufacturing process utilized to make composite profiles with constant cross-sections whereby reinforcements, in the form of roving and mats, are saturated with resin and guided into a heated die. The resin undergoes a curing process known as polymerization. The once resin saturated reinforcements exit the die in a solid state and in the form of the cross section of the die. The pultrusion process requires little labor and is ideal for mass production of constant cross section profiles.

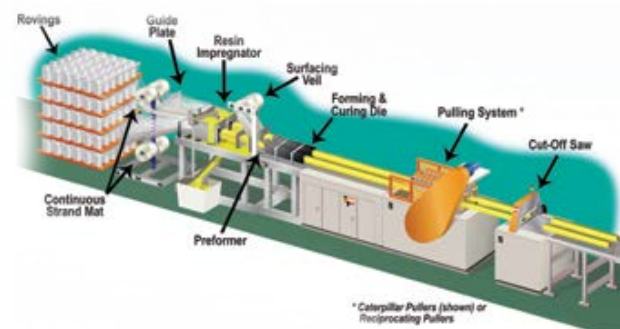

### WHAT DO OWNERS VALUE IN SUPERPILE®?

- **Longevity** - Significant Reductions of Future Capital Expenditures
- **Maintenance** - Significant Reductions of Future Maintenance Expenditures
- **Aesthetics** - No Rust Marks, Spalling, Rotting or Section Loss
- **Green** - Low Embodied Energy
- **Environmentally Friendly** - Will Not Leach Dangerous Pesticides, Antifungal or Preservatives into the Environment

### WHAT DO END USERS VALUE IN SUPERPILE®?

- **Functionality** - Performs as Designed and Intended
- **Aesthetics** - Professional Look
- **Performance** - Protects Your Boat and Structures

### WHAT DO ENGINEERS VALUE IN SUPERPILE®?

- **Engineered Product** - Unlike Wood, FRP is an Engineered Product with a Low Coefficient of Variation (COV)
- **High Strength** - Pound for Pound Stronger than Steel, Concrete and Wood
- **Low Modulus of Elasticity** - Dissipates Vessel Impact Energy
- **Versatile** - Can Be Used as a Foundation Bearing, Dock or Fender Pile
- **Reliable** - Design Values Are Based on a 95% Confidence Value
- **Design** - Can Be Designed Based on Load and Resistance Factor Design (LRFD) or Allowable Stress Design (ASD)
- **Factory Made** - Manufactured in an Environmentally Controlled Complex to Stringent Quality Assurance (QA) Standards

### WHAT DO CONTRACTORS VALUE IN SUPERPILE®?

- Significant Shipping Savings
- Drills and Cuts 2x Faster Than Thermoplastic Polymer Piles
- Driven with Standard Pile Driving Equipment
- Lightweight - 1/10th the Weight of a Concrete Pile and 1/4th the Weight of Steel
- Field Drillable
- Ease of Fabrication with Traditional Construction Tools

## FASTEST DRIVEN & LONGEST LASTING

**PDA Analysis, Virginia**



**PILE CONSTRUCTION**

SUPERPILE® Composite Pipe Pile is manufactured with electrical grade fiberglass and high impact, high strength polyurethane resin. The combination of the advanced resin and high strength glass produces a superior strength, highly corrosion resistant pipe pile.

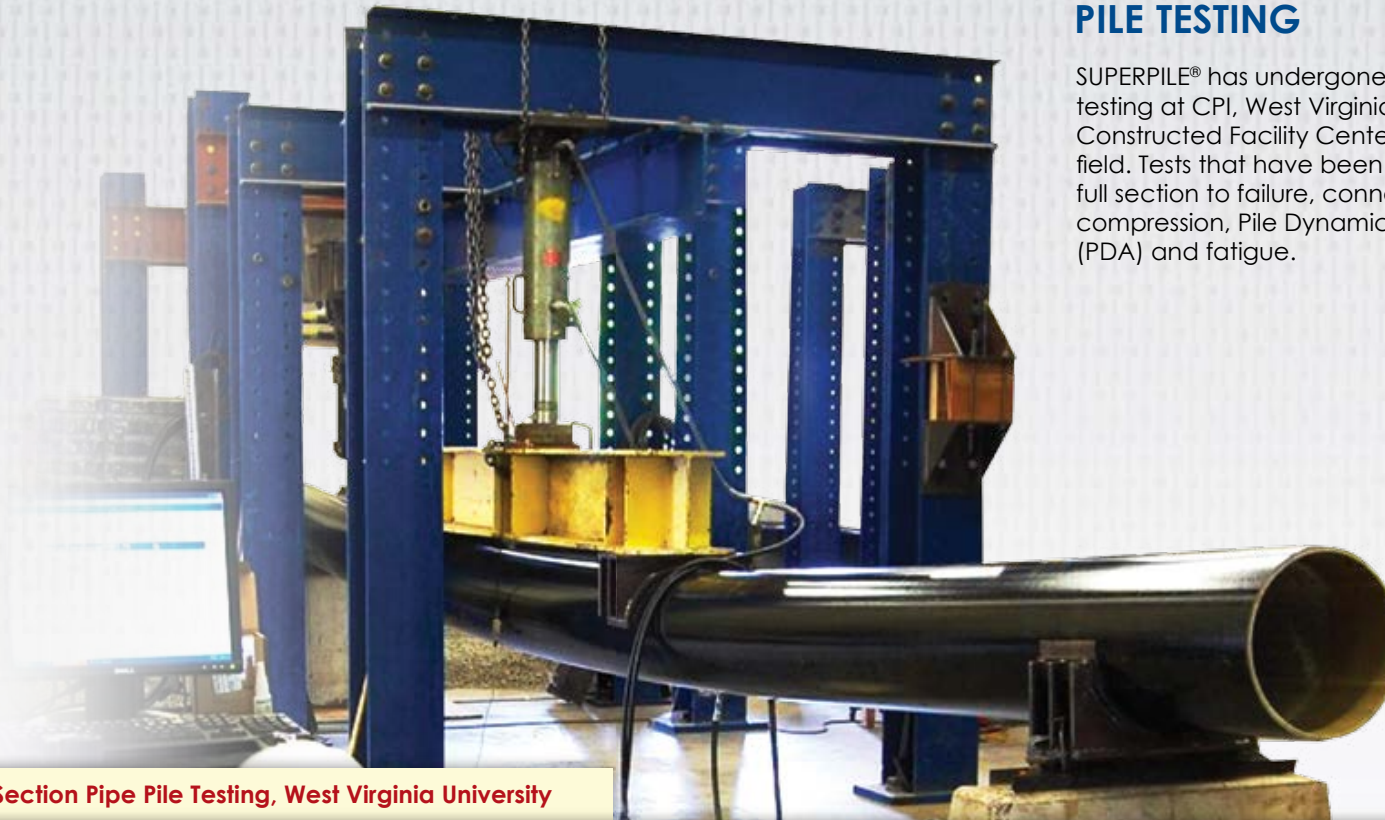

**Full Section Pipe Pile Testing, West Virginia University**

**PILE TESTING**

SUPERPILE® has undergone extensive testing at CPI, West Virginia University's Constructed Facility Center and in the field. Tests that have been conducted: full section to failure, connection, compression, Pile Dynamic Analysis (PDA) and fatigue.



**PDA Testing, Virginia**

"I have researched, tested and installed composite systems related to civil infrastructure over my entire career. **I was astonished at the high strength and modulus values achieved with the polyurethane pipe piles manufactured by Creative Pultrusions, Inc.** I expect that the US infrastructure will benefit greatly from this tubular pile technology."

~ Hota GangaRao, PhD, P.E., F. ASCE  
West Virginia University

**1. ADVANCED UV PROTECTION**

CPI's composite pipe piles are shipped standard with two layers of Ultra Violet (UV) protection. First, CPI adds light stabilizers to each pile. The light stabilizers are mixed into the thermoset resin, prior to production, and function as long term thermal and light stability promoters. Second, the composite pipe piles are encompassed with a 10 mil polyester surfacing veil. The 10 mil veil creates a resin rich surface and protects the glass reinforcements from fiber blooming. Additional UV and or abrasion barriers are available.

**2. RESIN/MATRIX**

The pipe piles are pultruded with high performance Vinyl Ester (VE) and Polyurethane resins. The octagonal pipe piles are manufactured with VE resin for its superior toughness and fatigue strength, VE resins are ideal for long term performance in harsh marine environments. The round pipe piles are manufactured standard with SUPURTUF™ Polyurethane resin. Polyurethane resins provide all of the performance of VE resins in addition to optimal strength, toughness and impact resistance. When it comes to high strength, toughness and impact properties, nothing outperforms SUPURTUF™ Polyurethane.

**3. FIBERGLASS REINFORCEMENTS**

All composite pipe piles are manufactured with electrical grade E-glass reinforcements in the form of unidirectional roving, Continuous Filament Mat (CFM) and stitched fabric mats. The combination of fiber reinforcements have been engineered for optimal bending and crush strength, as well as superior stiffness. All E-glass reinforcements meet a minimum tensile strength of 290 ksi per ASTM D2343.

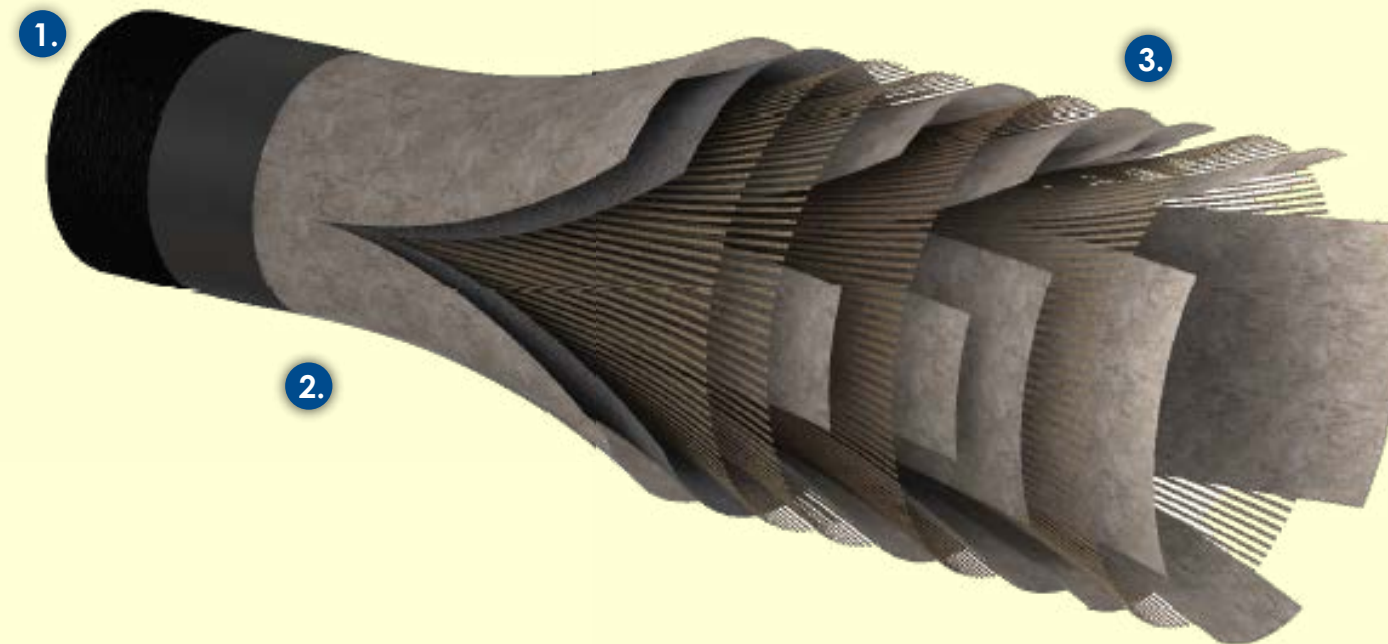

**WHY SHOULD YOU BUY & SPECIFY CPI PIPE PILES?**

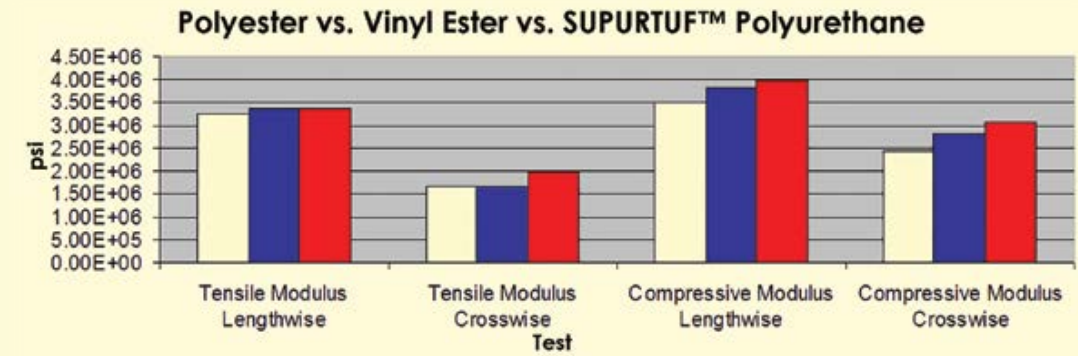
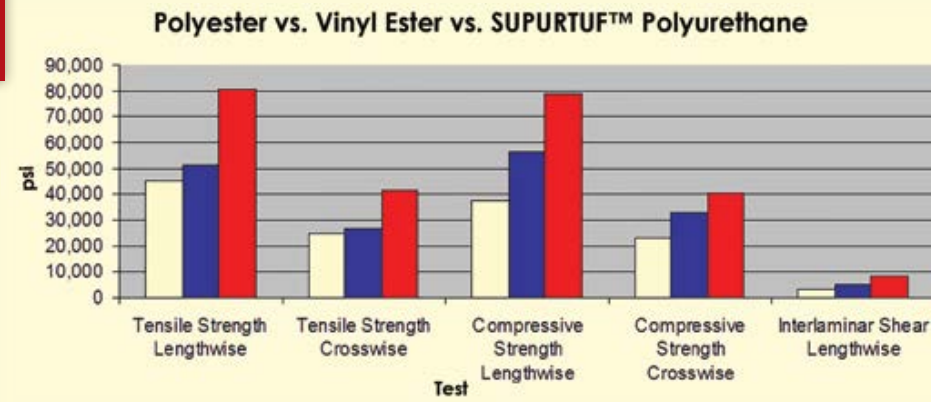
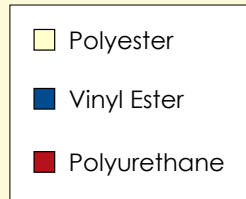

The graphs demonstrate a comparison of polyester, VE and Polyurethane resins. The fiber architecture is the same, only the resin type has been modified. The chart clearly demonstrates the strength advantage of VE and SUPURTUF™ Polyurethane resins over that of polyester composites.



**FASTEST DRIVEN**

Contractors all agree that the hollow SUPERPILE® drives twice as fast as solid wood, concrete and thermoplastic piles.



**LONGEST LASTING**

Long term durability projections predict a 75+ year service life.



**ENERGY ABSORPTION**

High strength, low modulus equates to very high energy absorption capacities when compared to wood, steel and concrete.

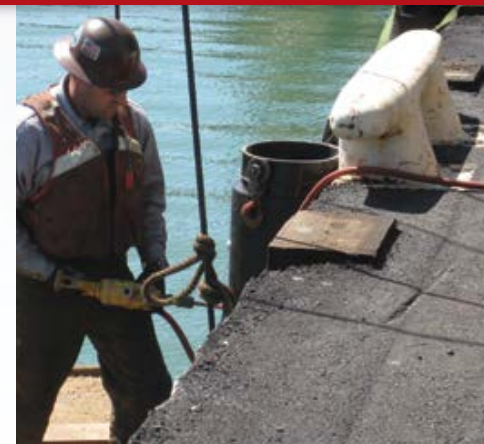

**EASE OF FABRICATION**

Can be field drilled and cut in seconds.



**NO LEACHING OF PRESERVATIVES, FUNGICIDES OR INSECTICIDES**

Environmentally friendly, the SUPERPILE® is inert, unlike wood that leaches dangerous chemicals into the environment.



**ENGINEERED SOLUTION**

Designed specifically for the piling market and manufactured in a production environment.

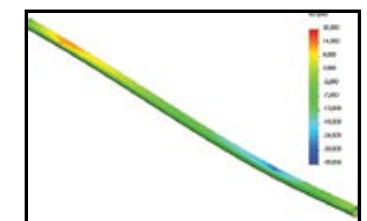



- **UNAFFECTED BY MARINE BORERS**

Will not succumb to aquatic mollusks or crustaceans.

- **WILL NOT ROT**

Inert to fungi or microbial attack.

- **LIGHTWEIGHT**

Significantly lighter than steel, concrete and wood piles.



- **SAFETY**

Very low electrical conductivity, ideal for working around power lines.

- **GREEN**

Low embodied energy.

- **NON-POLLUTING**

Accepted by NJDEP as non-polluting material for water and land use.

## WHAT ARE OWNERS AND CONTRACTORS SAYING ABOUT SUPERPILE®?



"Creative Pultrusions manufactured 190 SUPERPILES that were supplied by Lee Composites to Dutra Construction. The SUPERPILES replaced deteriorating creosote treated wood guide piles for the San Francisco Marina West Harbor Renovation Project. These piles are used as a fender by boats navigating in and out of their slips. The SUPERPILES are both aesthetically pleasing and have superior functionality to the treated wood piles. In addition, they are more environmentally friendly than their wood counterparts. They were installed very easily with a drop hammer and met all of our expectations. We expect these piles to stand the test of time by offering many years of maintenance free service. We expect to see a lot more of the SUPERPILES on future projects."

~Mike Edde  
Dutra Construction

San Francisco West Harbor Renovation Project  
December 2011 (Phase 1), San Francisco, California

"Creative Pultrusions manufactured and supplied fifty-two FRP SUPERPILES to me through Lee Composites. The piles were supplied to specification and arrived on time. The piles were of high quality and drove twice as fast as a solid pile. The 80' piles were lightweight and easy to handle. Given that the piles will not rot, rust or corrode, I anticipate driving many more SUPERPILES in the future. In fact, I see no reason not to use them!"

~Rich Walters  
R.A. Walters & Sons

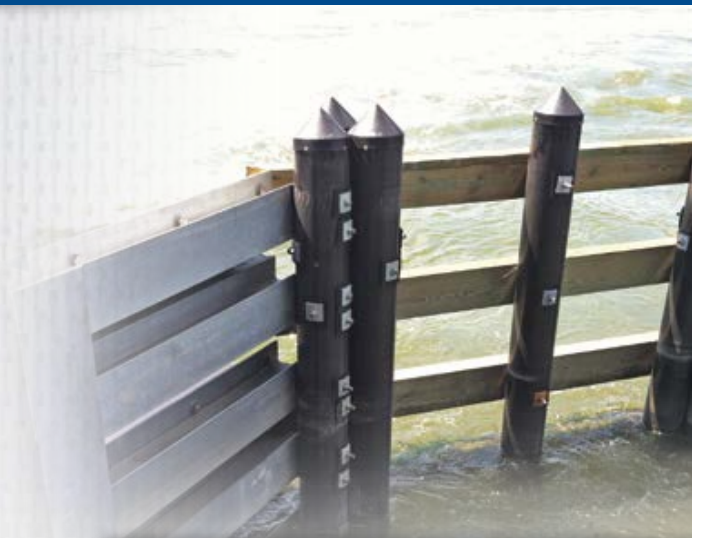

Margate Bridge Installation,  
Margate New Jersey

"When our Margate Bridge wooden fender system succumbed to the years of wear and tear in a hostile environment, we knew it was time to invest in a new fender system. We chose to specify the latest in fender technology and go with Creative Pultrusion's SUPERPILE. The piles were manufactured to spec. and delivered on time. The robust piles will protect our bridge foundations for many years without leaching any chemicals into our waterways. The piles made sense from a business and environmental standpoint, making the decision to procure the piles easy."

~David Goddard  
Ole Hansen and Sons, Inc.

"Upon award of the bid, Crofton knew that choosing the right supplier for the FRP piles was critical in order to get value engineering proposal approval by the project start date. Creative was the best choice since they have done extensive testing, are listed on multiple state's Qualified Products Lists and have the engineering support to assist in securing this approval.

Creative addressed all material related questions and concerns brought about by the Engineer of Record and VADOT engineering. In fact, they provided piles so that a PDA could be performed on the 16" dia. FRP SUPERPILE. The PDA eliminated all concerns and questions that Crofton and the Engineering firm had with regards to installation and connection details.

Not only did Creative supply a quality product at a fair price, they stood behind us through the entire project. The engineering team at CPI made my life easier and saved Crofton money in the process."

~Brad Gribble  
Crofton Industries



Fender Rehabilitation  
Route 3 Over Piankatank River, Virginia

## MECHANICAL & PHYSICAL PROPERTIES

### PIPE PILES

The mechanical and physical data detailed herein is provided for the structural engineer. The mechanical data is published in terms of average and characteristic values. The characteristic values were derived per the requirements as set forth in ASTM D7290 Standard Practice for Evaluating Material Property Characteristic Values for Polymeric Composites for Civil Engineering Structural Applications. The characteristic value is defined as a statistically-based material property representing the 80% lower confidence bound on the 5th-percentile value of a specified population. The characteristic value accounts for statistical uncertainty due to a finite sample size. The characteristic value is the reference strength.

In terms of Load and Resistance Factor Design (LRFD) design, the reference strength shall be adjusted for end use conditions by applying the applicable adjustment factors to establish the nominal resistance strength. The design strength shall include the nominal resistance, adjusted for end-

use conditions, a resistance factor and time effect factor. The reference strength and stiffness shall be multiplied by .85 and .95 respectively to establish the nominal strength and stiffness for installations in sea and fresh water. A time effect factor of 0.4 shall be applied for full design permanent loads that will act during the service life of the structure. Resistant factors shall be established as set forth in the LRFD of Pultruded Fiber Reinforced Polymer (FRP) Structures Pre-Standard. Serviceability shall be checked based on the adjusted average full section modulus of elasticity as established per ASTM D6109.

In terms of Allowable Stress Design (ASD), the pultrusion industry uses a 3.0 safety factor for compression members, 2.5 for flexural members, 3.0 for connections and 3.0 for shear. The characteristic reference strength shall be used for strength and the average E-modulus shall be used for serviceability calculations.

SUPERPILE® Mechanical Properties	Round FRP Pipe Pile TU455 Polyurethane 12"x3/8" Metric (305mm x 9.52mm)	Round FRP Pipe Pile TU450 Polyurethane 12"x1/2" Metric (305mm x 12.7mm)	Round FRP Pipe Pile TU460 Polyurethane 16"x1/2" Metric (406mm x 12.7mm)			
Average Flexural Strength per ASTM D6109 psi (Mpa)	52,000	(359)	69,658	(480)	57,270	(395)
Characteristic Flexural Strength per ASTM D6109 psi (Mpa) <sup>2</sup>	*****	*****	56,111	(387)	49,840	(344)
Average Compression Strength per ASTM D6109 psi (Mpa)	52,000	(359)	69,658	(480)	57,270	(395)
Characteristic Compression Strength per ASTM D6109 psi (Mpa) <sup>2</sup>	*****	*****	56,111	(387)	49,840	(344)
Average In-Plane Shear Strength psi (Mpa)	15,605	(108)	16,039	(111)	17,170	(118)
Characteristic In-Plane Shear Strength psi (Mpa)	13,212	(91)	13,713	(95)	14,936	(103)
Average Shear Capacity lbs (Kg)	106,894	(48,486)	145,153	(65,840)	208,616	(94,626)
Characteristic Shear Capacity lbs (Kg)	90,502	(41,051)	124,103	(56,292)	181,472	(82,314)
Average Torque Strength lb-ft (kN•m)	103,519	(140)	138,829	(188)	269,987	(366)
Characteristic Torque Strength lb-ft (kN•m)	87,644	(119)	118,696	(161)	234,859	(318)
Average Axial Compression Strength psi (Mpa)	52,000	(359)	69,658	(480)	57,270	(395)
Characteristic Axial Compression Strength psi (Mpa) <sup>2</sup>	*****	*****	56,111	(387)	49,840	(344)
Average Axial Compression Capacity (Short Column) lb (kg)	712,400	(323,139)	1,260,810	(571,894)	1,391,661	(631,247)
Characteristic Axial Compression Capacity (Short Column) lb (kg) <sup>2</sup>	*****	*****	1,015,609	(460,673)	1,211,112	(549,351)
Average Modulus of Elasticity per ASTM D6109 psi (Gpa)	5.26E+06	(36.3)	5.91E+06	(40.7)	5.99E+06	(41.3)
Bending Stiffness (EI) per ASTM D6109 lbs•in <sup>2</sup> (kg•mm <sup>2</sup> )	1.22E+09	(3.57E+11)	1.77E+09	(5.17E+11)	4.38E+09	(1.28E+12)
Average Moment Capacity per ASTM D6109 kip-ft (kN•m)	167	(227)	289	(392)	437	(592)

## MECHANICAL & PHYSICAL PROPERTIES

### PIPE PILES

SUPERPILE® Mechanical Properties	Round FRP Pipe Pile TU455 Polyurethane 12"x3/8" Metric (305mm x 9.52mm)	Round FRP Pipe Pile TU450 Polyurethane 12"x1/2" Metric (305mm x 12.7mm)	Round FRP Pipe Pile TU460 Polyurethane 16"x1/2" Metric (406mm x 12.7mm)			
Characteristic Moment Capacity per ASTM D6109 kip-ft (kN•m) <sup>2</sup>	*****	*****	233	(316)	380	(515)
Average Energy Absorption kip-in (kN•m)	341	(39)	643	(73)	829	(94)
Characteristic Energy Absorption kip-in (kN•m) <sup>2</sup>	*****	*****	405	(46)	603	(68)
Average Pin Bearing Strength Crosswise psi (Mpa)	19,823	(137)	21,676	(149)	23,666	(163)
Characteristic Pin Bearing Strength Crosswise psi (Mpa)	12,447	(86)	12,546	(87)	20,771	(143)
Average Pin Bearing Strength Lengthwise psi (Mpa)	30,793	(212)	30,149	(208)	27,788	(192)
Characteristic Pin Bearing Strength Lengthwise psi (Mpa)	18,053	(125)	25,132	(173)	19,217	(133)
Average Pile Crush Strength lb (kg) (based on a 9" wide load path) <sup>1</sup>	10,600	(4,808)	17,970	(8,151)	16,600	(7,530)
Characteristic Pile Crush Strength lb (kg) (based on a 9" wide load path) <sup>1</sup>	8,060	(3,656)	13,782	(6,251)	11,667	(5,292)
Average Crush Strength, with FRP Insert, lb (kg) (based on a 9" wide load path) <sup>1,2</sup>	*****	*****	73,780	(33,466)	44,213	(20,055)
Characteristic Crush Strength, with FRP Insert, lb (kg) (based on a 9" wide load path) <sup>1,2</sup>	*****	*****	51,370	(23,301)	*****	*****
Average Washer Pull Through Strength lb (kg) using a 6"x1/2" square/radius washer	26,084	(11,832)	30,686	(13,919)	27,582	(12,511)
Characteristic Washer Pull Through Strength lb (kg) using a 6"x1/2" square/radius washer	22,107	(10,028)	26,815	(12,163)	25,103	(11,387)
Average Washer Pull Through Strength lb (kg) using a 6"x3/8" square/radius washer	18,893	(8,570)	25,205	(11,433)	18,878	(8,563)
Characteristic Washer Pull Through Strength lb (kg) using a 6"x3/8" square/radius washer	13,977	(6,340)	22,420	(10,170)	13,521	(6,133)
Allowable torque permitted on a bolted connection with a 6" radius washer lb-ft (N•m)	50	(68)	50	(68)	50	(68)
SUPERPILE® Physical Properties	Round FRP Pipe Pile TU455 Polyurethane 12"x3/8" Metric (305mm x 9.52mm)	Round FRP Pipe Pile TU450 Polyurethane 12"x1/2" Metric (305mm x 12.7mm)	Round FRP Pipe Pile TU460 Polyurethane 16"x1/2" Metric (406mm x 12.7mm)			
Diameter in (cm)	12	(30.48)	12	(30.48)	16	(40.64)
Wall thickness in (mm)	0.375	(9.5)	0.5	(12.7)	0.5	(12.7)
Moment of Inertia in <sup>4</sup> (cm <sup>4</sup> )	232	(9,657)	299	(12,445)	732	(30,468)
Section Modulus in <sup>3</sup> (cm <sup>3</sup> )	38.6	(633)	49.8	(816)	91.5	(1,499)
Radius of Gyration in (mm)	4.11	(104)	4.07	(103)	5.48	(139)
Weight lb/ft (Kg/m)	12.6	(18.8)	16.9	(25.1)	22.6	(33.6)
Coefficient of Thermal Expansion (CTE) Lengthwise in/in/°F (mm/mm/°C)	5.00E-06	(9.00E-06)	5.00E-06	(9.00E-06)	5.00E-06	(9.00E-06)
Water Absorption ASTM D570	0.15% (24hrs)	0.15% (24hrs)	0.15% (24hrs)	0.15% (24hrs)	0.15% (24hrs)	0.15% (24hrs)
Fiber Volume Fraction %	≥50%	≥50%	≥50%	≥50%	≥50%	≥50%
Cross Sectional Area in <sup>2</sup> (cm <sup>2</sup> )	13.7	(88)	18.1	(116.8)	24.3	(156.8)
Surface Area ft <sup>2</sup> /ft (m <sup>2</sup> /m)	3.14	(0.96)	3.14	(0.96)	4.19	(1.28)

<sup>1</sup>The crush strength value is based on full section testing. The strength value was recorded at the first audible sound and change in the load deflection curve. The ultimate capacity is approximately 60% higher and is defined as the highest recorded load documented during the crush strength test.

<sup>2</sup>Characteristic data is unavailable due to the number of tests required. A minimum of 10 tests are required to generate the ASTM D7290 characteristic values.

## MECHANICAL & PHYSICAL PROPERTIES

### OCTAGONAL PILES

The mechanical and physical data detailed herein is provided for the structural engineer. The mechanical data is published in terms of average value and either characteristic or 5% Lower Exclusion Limit (LEL) values. The characteristic values were derived per the requirements as set forth in ASTM D7290 Standard Practice for Evaluating Material Property Characteristic Values for Polymeric Composites for Civil Engineering Structural Applications. The characteristic value is defined as a statistically-based material property representing the 80% lower confidence bound on the 5th-percentile value of a specified population. In instances where sufficient data was not available to calculate the characteristic value, a 5% LEL was calculated. The 5% LEL, like the characteristic value, is the 5th-percentile value, however it is somewhat less conservative in that it does not account for the 80% lower confidence bound. The values are listed to account for statistical uncertainty due to a finite sample size. These statistically reduced values should be used as the reference strength.

In terms of Load and Resistance Factor Design (LRFD) design, the reference strength shall be

adjusted for end use conditions by applying the applicable adjustment factors to establish the nominal resistance strength. The design strength shall include the nominal resistance, adjusted for end-use conditions, a resistance factor and time effect factor. The reference strength and stiffness shall be multiplied by .85 and .95 respectively to establish the nominal strength and stiffness for installations in sea and fresh water. A time effect factor of 0.4 shall be applied for full design permanent loads that will act during the service life of the structure. Resistant factors shall be established as set forth in the LRFD of Pultruded Fiber Reinforced Polymer (FRP) Structures Pre-Standard. Serviceability shall be checked based on the adjusted average full section modulus of elasticity as established per ASTM D1036.

In terms of Allowable Stress Design (ASD), the pultrusion industry uses a 3.0 safety factor for compression members, 2.5 for flexural members, 3.0 for connections, and 3.0 for shear. The reference strength shall be used for strength and the average modulus shall be used for serviceability calculations.

Octagonal Pile Mechanical Properties	Octagonal Pile 8"x.25" Series II CP076 (203mm x 6.35mm)		Octagonal Pile 10"x.25"Series II CP074 (254mm x 6.35mm)		Octagonal Pile 10"x.275" Series III CP210 (254mm x 6.98mm)	
Average Flexural Strength per ASTM D1036 psi (Mpa)	49,173	(339)	43,832	(302)	43,893	(303)
5% LEL Flexural Strength per ASTM D1036 psi (Mpa) <sup>1</sup>	46,999	(324)	41,374	(285)	42,076	(290)
Average Compression Strength per ASTM D1036 psi (Mpa)	49,173	(339)	43,832	(302)	43,893	(303)
5% LEL Compression Strength per ASTM D1036 psi (Mpa) <sup>1</sup>	46,999	(324)	41,374	(285)	42,076	(290)
Average In-Plane Shear Strength psi (Mpa)	12,554	(87)	12,706	(88)	12,866	(89)
Characteristic In-Plane Shear Strength psi (Mpa)	10,940	(75)	10,101	(70)	11,616	(80)
Average Shear Capacity lbs (Kg)	48,458	(21,980)	68,359	(31,007)	86,649	(39,304)
Characteristic Shear Capacity lbs (Kg)	42,230	(19,155)	54,344	(24,650)	78,237	(35,488)
Average Torque Strength lb-ft (kN•m)	24,675	(33)	41,166	(56)	45,621	(62)
Characteristic Torque Strength lb-ft (kN•m)	21,504	(29)	32,726	(44)	41,191	(56)
Average Axial Compression Strength psi (Mpa)	49,173	(339)	43,832	(302)	43,893	(303)
5% LEL Axial Compression Strength psi (Mpa) <sup>1</sup>	46,999	(324)	41,374	(285)	42,076	(290)
Average Axial Compression Capacity (Short Column) lb (kg)	379,617	(172,191)	471,634	(213,930)	591,245	(268,184)
5% LEL Axial Compression Capacity (Short Column) lb (kg) <sup>1</sup>	362,832	(164,578)	445,184	(201,932)	566,764	(257,080)
Average Modulus of Elasticity per ASTM D1036 psi (Gpa)	4.30E+06	(29.6)	4.00E+06	(27.6)	3.70E+06	(25.5)
Bending Stiffness (EI) per ASTM 1036 lbs•in <sup>2</sup> (kg•mm <sup>2</sup> )	2.62E+08	(7.67E+10)	5.58E+08	(1.63E+11)	6.35E+08	(1.86E+11)
Average Moment Capacity per ASTM D1036 kip-ft (kN•m)	62	(85)	100	(136)	123	(167)
5% LEL Moment Capacity per ASTM D1036 kip-ft (kN•m) <sup>1</sup>	60	(81)	94	(128)	118	(160)
Average Pin Bearing Strength Crosswise psi (Mpa)	15,357	(106)	11,562	(80)	11,280	(78)
Characteristic Pin Bearing Strength Crosswise psi (Mpa)	8,131	(56)	5,839	(40)	5,453	(38)

## MECHANICAL & PHYSICAL PROPERTIES

### OCTAGONAL PILES

Octagonal Pile Mechanical Properties	Octagonal Pile 8"x.25" Series II CP076 (203mm x 6.35mm)		Octagonal Pile 10"x.25"Series II CP074 (254mm x 6.35mm)		Octagonal Pile 10"x.275" Series III CP210 (254mm x 6.98mm)	
Average Pin Bearing Strength Lengthwise psi (Mpa)	27,263	(188)	28,223	(195)	27,132	(187)
Characteristic Pin Bearing Strength Lengthwise psi (Mpa)	16,679	(115)	21,029	(145)	12,867	(89)
Average Washer Pull Through Strength lb (kg) using a 4"x3/8" square washer	13,697	(6,213)	14,698	(6,667)	14,571	(6,609)
Characteristic Washer Pull Through Strength lb (kg) using a 4"x3/8" square washer	10,705	(4,856)	11,916	(5,405)	11,798	(5,351)
Allowable torque permitted on a bolted connection with a 4"x3/8" square washer lb-ft (N•m)	50	(68)	50	(68)	50	(68)

Octagonal Pile Physical Properties	Octagonal Pile 8"x.25" Series II CP076 (203mm x 6.35mm)		Octagonal Pile 10"x.25"Series II CP074 (254mm x 6.35mm)		Octagonal Pile 10"x.275" Series III CP210 (254mm x 6.98mm)	
Diameter in (cm)	8	(20.32)	10.2	(25.91)	10.2	(25.91)
Wall thickness in (mm)	0.25	(6.4)	0.25	(6.4)	0.275	(7.0)
Moment of Inertia in <sup>4</sup> (cm <sup>4</sup> )	60.87	(2,534)	139.69	(5,814)	171.57	(7,141)
Section Modulus in <sup>3</sup> (cm <sup>3</sup> )	15.22	(249)	27.39	(449)	33.64	(551)
Radius of Gyration in (mm)	2.81	(71)	3.60	(91)	11.05	(281)
Weight lb/ft (Kg/m)	6.33	(9)	8.82	(13.1)	11.05	(16.4)
Coefficient of Thermal Expansion (CTE) Lengthwise in/in/°F (mm/mm/°C)	5.00E-06	(9.00E-06)	5.00E-06	(9.00E-06)	5.00E-06	(9.00E-06)
Water Absorption ASTM D570	0.60% (24hrs)	0.60% (24hrs)	0.60% (24hrs)	0.60% (24hrs)	0.60% (24hrs)	0.60% (24hrs)
Fiber Volume Fraction %	≥50%	≥50%	≥50%	≥50%	≥50%	≥50%
Cross Sectional Area in <sup>2</sup> (cm <sup>2</sup> )	7.72	(50)	10.76	(69.4)	13.47	(86.9)
Surface Area ft <sup>2</sup> /ft (m <sup>2</sup> /m)	2.20	(0.67)	2.80	(0.85)	2.80	(0.85)

Octagonal Pile Fire Properties	Octagonal Pile 8"x.25" Series II CP076 (203mm x 6.35mm)	Octagonal Pile 10"x.25"Series II CP074 (254mm x 6.35mm)	Octagonal Pile 10"x.275" Series III CP210 (254mm x 6.98mm)
Flame Rating (UL 94)	V0 Self Extinguishing	V0 Self Extinguishing	V0 Self Extinguishing
Flame Spread ASTM E-84	Class A 25 or less	Class A 25 or less	Class A 25 or less

Octagonal Pile Electrical Properties	Octagonal Pile 8"x.25" Series II CP076 (203mm x 6.35mm)	Octagonal Pile 10"x.25"Series II CP074 (254mm x 6.35mm)	Octagonal Pile 10"x.275" Series III CP210 (254mm x 6.98mm)
ASTM F711 (100 kVAC per foot - 5 minutes dry)	Passed	Passed	Passed
IEEE978 (75 kVAC per foot - 1 minute wet)	Passed	Passed	Passed

Notes:

<sup>1</sup>5% Lower Exclusion Limit (LEL) was used as a statistical knockdown in instances where the sufficient number of data points was not available to calculate the characteristic value.

<sup>2</sup>All connection testing was conducted utilizing 3/4" hardware.

The Mechanical and Physical Property Charts for the Octagonal piles have been developed based on extensive third party and in house testing.

### THERMOPLASTIC PIPE PILE AND SLEEVE COMPARISON

Specification Test Requirement	Standard Title	SUPERPILE®	CPI Supplied HDPE Sleeve(when applicable)	Required Properties for FRP Composite Lumber (SCL)
ASTM D792	Standard Test Methods for Density and Specific Gravity (Relative Density) of Plastics by Displacement	Density = 122.3 pcf Void Content < 1%	59.9 pcf (tested D1505)	55-63 pcf
ASTM D570	Standard Test Method for Water Absorption of Plastics	0.15% (24hrs)	.01-.1% (From www.matweb.com HDPE Extruded)	2hrs <1.0% weight increase 24hrs <3.0% weight increase
ASTM D746	Standard Test Method for Brittleness Temperature of Plastics and Elastomers by Impact	Test using ASTM D7028 (DMA) Tan Delta Peak = 132°C G' (-50°C) = 6.5 GPa G' (25°C) = 5.29 GPa <sup>1</sup>	< -75-deg C	Brittleness Temp < -40-deg C
ASTM D256	Standard Test Methods for Determining the Izod Pendulum Impact Resistance of Plastics	90 ft-lb/in	1.47-11.0 ft-lb/in (From www.matweb.com HDPE Pipe Grade)	> 0.55ft-lb/in
ASTM D2240	Standard Test Method for Rubber Property—Durometer Hardness	85 Shore D	62 Shore D	44-75 (Shore D)
ASTM D4329	Standard Practice for Fluorescent UV Exposure of Plastics	No measurable hardness change after 1344hrs UV exposure		500 hours < 10% change in Hardness
ASTM D4060	Standard Test Method for Abrasion Resistance of Organic Coatings by the Taber Abraser	0.0035 oz	0.002 oz (web search)	Weight Loss < 0.02oz Cycles = 10,000 Wheel = CS17 Load - 2.2lb
ASTM D756	Practice for Determination of Weight and Shape Changes of Plastics Under Accelerated Service Conditions (Sea Water, Gasoline, No. 2 Diesel)	Sea Water = 0.32% Wt Increase <sup>2</sup> Gasoline = 0.33% Wt Increase <sup>2</sup> No. 2 Diesel = 0.14% Wt Increase <sup>2</sup>		Sea Water < 1.5% Weight Increase Gasoline < 9.5% Weight Increase No. 2 Diesel < 6.0% Weight Increase
ASTM D638	Standard Test Method for Tensile Properties of Plastics	136000 psi	> 3,500psi (yield)	Min. 2,200 psi @ Break (Strength)
ASTM D695	Standard Test Method for Compressive Properties of Rigid Plastics	6.40E+06 psi	> 175,000 psi (Tested D638 Tension)	Min. 40,000 psi @ Break (Modulus)
ASTM D1894	Standard Test Method for Static and Kinetic Coefficients of Friction of Plastic Film and Sheeting	Static 0.152 dry; 0.227 wet Kinetic 0.139 dry; 0.140 wet	0.2-0.25	Max. 0.25 Wet
ASTM D6117	Standard Test Methods for Mechanical Fasteners in Plastic Lumber and Shapes	1,728 lb (1/4"-14 x 1.5" Long SS Hex Head Self Drilling Screw)		Min. 60lb

SUPERPILE® Specification:

Resin: Resin shall be a low VOC two component polyol/isocyanate polyurethane. The minimum resin content shall be 47% by volume and shall not contain fillers.

Reinforcements: The reinforcement shall be E or Ncr glass providing reinforcement in the lengthwise, transverse and bias directions. The profile shall contain 38% by volume of reinforcements in the lengthwise direction and 14% minimum in the transverse directions. The outermost layer of the composite pile shall be encompassed with 10 mil polyester veil, providing a resin rich UV protective layer.

<sup>1</sup> The material is established to be non brittle at -50°C due to the relatively low change in G' compared to 25°C.

<sup>2</sup> Parts were submerged in the fluid for 2 weeks before checking absorption.



## SUPERPILE® MECHANICAL LOAD CHARTS

SUPERPILE® is ideal for bridge and dock fendering. The high strength attributes combined with the mid range Modulus of Elasticity (MOE) permits SUPERPILE® to absorb a high amount of energy. The SUPERPILE® Energy Absorption Capacity Chart details the energy absorption capacity in terms of the average and characteristic values. The values were derived from full section testing to failure based on ASTM D6109. The energy calculation is derived by calculating the area under the load deflection curve.

### SUPERPILE® ENERGY ABSORPTION CHART

Round FRP Pipe Pile TU455 Polyurethane 12"x3/8" Metric (305mmx9.52mm)	Round FRP Pipe Pile TU450 Polyurethane 12"x1/2" Metric (305mmx12.7mm)	Round FRP Pipe Pile TU460 Polyurethane 16"x1/2" Metric (406mmx12.7mm)
Average Energy Absorption kip-in (kN•m) ASTM D6109		
341 (39)	643 (73)	829 (94)
Characteristic Energy Absorption kip-in (kN•m) ASTM D6109		
*****	405 (46)	603 (68)

Notes:  
\*\*\*\*\* Data not available or minimum test quantity not available.

### SUPERPILE® BOLTED CONNECTION CAPACITY CHARTS

The following charts depict the round and octagonal piles bolted characteristic connection capacity. Specifically, the piles were tested by positioning a 3/4" dia. rod through the octagonal piles and 1" dia. rod through the round pipe piles. The rods were loaded as depicted in the photos until an ultimate load was achieved. The ultimate load is defined as the maximum recorded load. The failure mode is pin bearing of the FRP material. The tests were conducted in both the lengthwise and transverse directions. The ultimate pin bearing stress was calculated based on the pin diameter, wall thickness and the fact that the rod penetrated two walls. The values used to make the chart were derived from the pin bearing strength obtained during testing. The charts values are based on the diameter of the bolt or bolts in the connection, the number of bolts and the pile series. The average and characteristic values are included and represent the capacity of a bolt loaded entirely on one side of the pile as depicted in the photograph. The thermoplastic wale, although connected with a bolt that protrudes through both walls of the pipe pile, is supported by the pin bearing strength of one wall, in the lengthwise direction of the FRP pile.



### Characteristic Strengths of Bolted Connections for Forces Applied Parallel to the Pile

Round Polyurethane Piles	Single 5/8" Bolt	Two 5/8" Bolts	Single 3/4" Bolt	Two 3/4" Bolts	Single 1" Bolt	Two 1" Bolts
TU455 12" x 3/8" (305mmx9.52mm)	4,231	8,462	5,077	10,155	6,770	13,540
TU450 12" x 1/2" (305mmx12.7mm)	7,854	15,708	9,425	18,849	12,566	25,132
TU460 16" x 1/2" (406mmx12.7mm)	6,005	12,011	7,206	14,413	9,609	19,217
Octagonal Vinyl Ester Piles	Single 5/8" Bolt	Two 5/8" Bolts	Single 3/4" Bolt	Two 3/4" Bolts	Single 1" Bolt	Two 1" Bolts
CP076 8" x .25" (203mmx6.35mm)	2,606	5,212	3,127	6,255	4,170	8,340
CP074 10" x .25" (254mmx6.35mm)	3,286	6,572	3,943	7,886	5,257	10,515
CP210 10" x .275" (254mmx6.98mm)	2,212	4,423	2,654	5,308	3,539	7,077

Notes:  
Table published based on characteristic values per ASTM D7290; proper safety factors are required.



Bolted Connection Test - Parallel



Bolted Connection Test - Perpendicular

### Characteristic Strengths of Bolted Connections for Forces Applied Perpendicular to the Pile

Round Polyurethane Piles	Single 5/8" Bolt	Two 5/8" Bolts	Single 3/4" Bolt	Two 3/4" Bolts	Single 1" Bolt	Two 1" Bolts
TU455 12" x 3/8" (305mmx9.52mm)	2,917	5,835	3,501	7,001	4,668	9,335
TU450 12" x 1/2" (305mmx12.7mm)	3,921	7,841	4,705	9,410	6,273	12,546
TU460 16" x 1/2" (406mmx12.7mm)	6,491	12,982	7,789	15,578	10,386	20,771
Octagonal Vinyl Ester Piles	Single 5/8" Bolt	Two 5/8" Bolts	Single 3/4" Bolt	Two 3/4" Bolts	Single 1" Bolt	Two 1" Bolts
CP076 8" x .25" (203mmx6.35mm)	1,271	2,541	1,525	3,049	2,033	4,066
CP074 10" x .25" (254mmx6.35mm)	912	1,825	1,095	2,190	1,460	2,919
CP210 10" x .275" (254mmx6.98mm)	937	1,875	1,125	2,249	1,500	2,999

Notes:  
Table published based on characteristic values per ASTM D7290; proper safety factors are required.

## SUPERPILE® MECHANICAL LOAD CHARTS

### SUPERPILE® CRUSH STRENGTH CHARTS

SUPERPILE® sections were tested to evaluate the full section crush strength. Both the 12" and the 16" piles were tested. The 1/2" thick piles were tested with and without an FRP insert. The insert was developed to increase the crush strength in strategic locations within the pile that will have high stress concentrations. The test setup, as depicted in the photograph, involves a section of SUPERPILE® with an induced load applied through a 10" x 10" thermoplastic wale section.

The crush strength was determined based on the recorded load that caused an initial change in the load deflection curve and is the value listed in the charts. The ultimate load, defined as the ultimate load recorded during the test, is approximately 60% higher than the loads depicted in the charts.

SUPERPILE® Crush Strength with a 10" x 10" (24.5mm x 24.5mm) Thermoplastic Wale					
Round FRP Pipe Pile TU455 Polyurethane 12"x3/8" Metric (305mm x 9.52mm)		Round FRP Pipe Pile TU450 Polyurethane 12"x1/2" Metric (305mm x 12.7mm)		Round FRP Pipe Pile TU460 Polyurethane 16"x1/2" Metric (406mm x 12.7mm)	
Average Crush Strength lb (kg)					
10,600	(4,808)	17,970	(8,151)	16,600	(7,530)
Characteristic Crush Strength lb (kg)					
8,060	(3,656)	13,782	(6,251)	11,667	(5,292)



SUPERPILE® Crush Strength Test Set Up



SUPERPILE® with Insert, Crush Strength Test Set Up

SUPERPILE®, with FRP Insert, Crush Strength with a 10" x 10" (25.4mm x 25.4mm) Thermoplastic Wale					
Round FRP Pipe Pile TU455 Polyurethane 12"x3/8" Metric (305mm x 9.52mm)		Round FRP Pipe Pile TU450 Polyurethane 12"x1/2" Metric (305mm x 12.7mm)		Round FRP Pipe Pile TU460 Polyurethane 16"x1/2" Metric (406mm x 12.7mm)	
Average Crush Strength lb (kg)					
*****	*****	73,780	(33,466)	44,213	(20,055)
Characteristic Crush Strength lb (kg)					
*****	*****	51,370	(23,301)	*****	*****

Notes:  
\*\*\*\*\* Data not available or minimum test quantity not available.

## SUPERPILE® MECHANICAL LOAD CHARTS

### WASHER PULL THROUGH CHARTS

The round and octagonal pipe piles were tested to determine the washer pull through capacity. The test set up, as depicted in the photo, involves a series of tests in which 6" steel washers, bent to the required radius were loaded to simulate a connection in which the load causes the washer to pull through the pile. The failure load is the load recorded at the first drop in strength on the load/deflection curve. In most cases, the washer deformed prior to the failure load. Note that curved washers are required for use with the round pile and straight washers are required for use with the octagonal piles.

SUPERPILE® Washer Pull Through Strength with a 6"x1/2" (152mm x 12.7mm) Steel Washer					
Round FRP Pipe Pile TU455 Polyurethane 12"x3/8" Metric (305mm x 9.52mm)		Round FRP Pipe Pile TU450 Polyurethane 12"x1/2" Metric (305mm x 12.7mm)		Round FRP Pipe Pile TU460 Polyurethane 16"x1/2" Metric (406mm x 12.7mm)	
Average Pull Through Strength lb (kg)					
26,084	(11,832)	30,686	(13,919)	27,582	(12,511)
Characteristic Pull Through Strength lb (kg)					
22,107	(10,028)	26,815	(12,163)	25,103	(11,387)

SUPERPILE® Washer Pull Through Strength with a 6"x3/8" (152mm x 9.5mm) Steel Washer					
Round FRP Pipe Pile TU455 Polyurethane 12"x3/8" Metric (305mm x 9.52mm)		Round FRP Pipe Pile TU450 Polyurethane 12"x1/2" Metric (305mm x 12.7mm)		Round FRP Pipe Pile TU460 Polyurethane 16"x1/2" Metric (406mm x 12.7mm)	
Average Pull Through Strength lb (kg)					
18,893	(8,570)	25,205	(11,433)	18,878	(8,563)
Characteristic Pull Through Strength lb (kg)					
13,977	(6,340)	22,420	(10,170)	13,521	(6,133)

SUPERPILE® Washer Pull Through Strength with a 4"x3/8" (102mm x 9.5mm) Steel Washer					
Octagonal FRP Pile 8"x.25" Series II CP076 Metric (203mm x 6.35mm)		Octagonal FRP Pile 10"x.25" Series II CP074 Metric (254mm x 6.35mm)		Octagonal FRP Pile 10"x.275" Series III CP210 Metric (254mm x 6.98mm)	
Average Pull Through Strength lb (kg)					
13,697	(6,213)	14,698	(6,667)	14,571	(6,609)
Characteristic Pull Through Strength lb (kg)					
10,705	(4,856)	11,916	(5,405)	11,798	(5,351)



SUPERPILE® Washer Push Pull Through Test Set Up



SUPERPILE® Typical Dock to Pile Connection

### TYPICAL DOCK TO FENDER PILE CONNECTION

The pile/dock connection cartoon illustrates an attachment scheme that alleviates stress risers. Specifically, hollow composite pipe piles, although extremely strong and robust, have a lower modulus of elasticity than steel. The ability of the FRP material to distribute high load concentrations is not the same as a steel pipe. Therefore, the correct connection details are important in dock fender design. High stress concentration pipe pile connections should include a steel washer or wood block that wraps 1/4 to 1/2 the way around the pile. Tangential loads should be avoided. The chart depicts the loads that can be induced into the pile with a connection that is typical of the test set up and detail cartoon.

## TYPICAL DOCK TO FENDER PILE CONNECTION



**SUPERPILE® Typical Dock to Pile Connection Capacity Test Set Up**

SUPERPILE® Dock Connection Capacity for Fender Applications		
Round FRP Pipe Pile TU455 Polyurethane 12"x3/8" Metric (305mm x 9.52mm)	Round FRP Pipe Pile TU450 Polyurethane 12"x1/2" Metric (305mm x 12.7mm)	Round FRP Pipe Pile TU460 Polyurethane 16"x1/2" Metric (406mm x 12.7mm)
Average Connection Capacity lb (kg)		
26,084 (11,832)	30,686 (13,919)	27,582 (12,511)
Characteristic Connection Capacity		
22,107 (10,028)	26,815 (12,163)	25,103 (11,387)

The chart depicting the dock connection capacity is based on crush strength testing conducted with a 9" long by 6" wide by 1/2" thick steel washer.

## SLEEVE OPTIONS THICK AND THIN

The FRP Polyurethane SUPERPILE® exhibits very good abrasion resistance qualities. However, for applications in which continuous rubbing or severe scour can take place, CPI recommends that the pile and/or watercraft be protected with the use of a High Density Polyethylene (HDPE) sleeve. CPI offers several HDPE sleeve profiles.

A thin wall casing sleeve with a thickness of 0.175" (4.4mm), and a thick wall pipe sleeve with a minimum wall thickness of .824" (21mm), are offered for the 12" diameter pipe pile. The resin compound used for the manufacture of polyethylene casing shall be high-density polyethylene with a minimum cell classification of PE334430C, when classified in accordance with ASTM D3350. The thick wall sleeve is classified as a 14" DR 17IPS HDPE Pipe. The 16" diameter pile requires an 18" DR26 IPS Pipe with a minimum wall thickness of .692" (17.6mm).



**Thin Wall Sleeve**

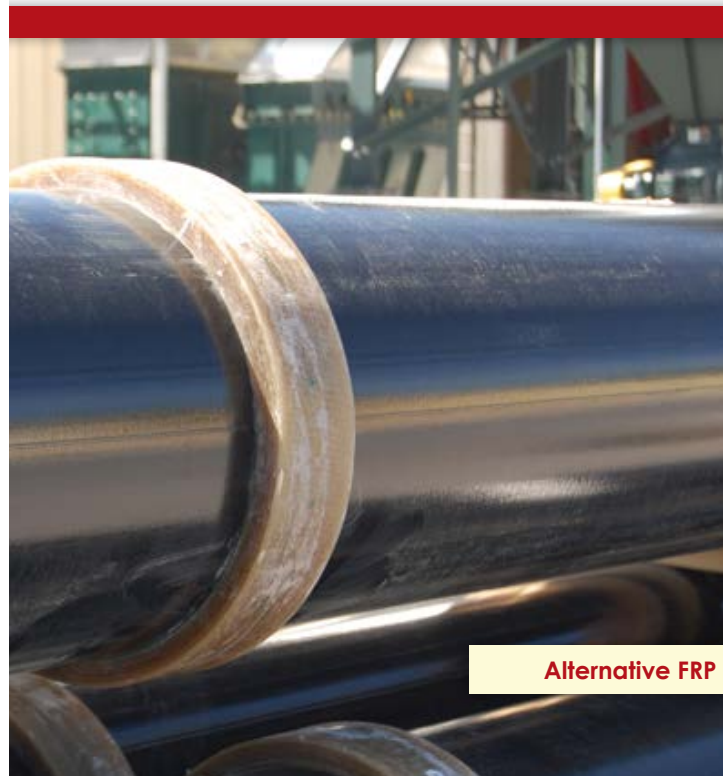

**Alternative FRP Ring Close Up**

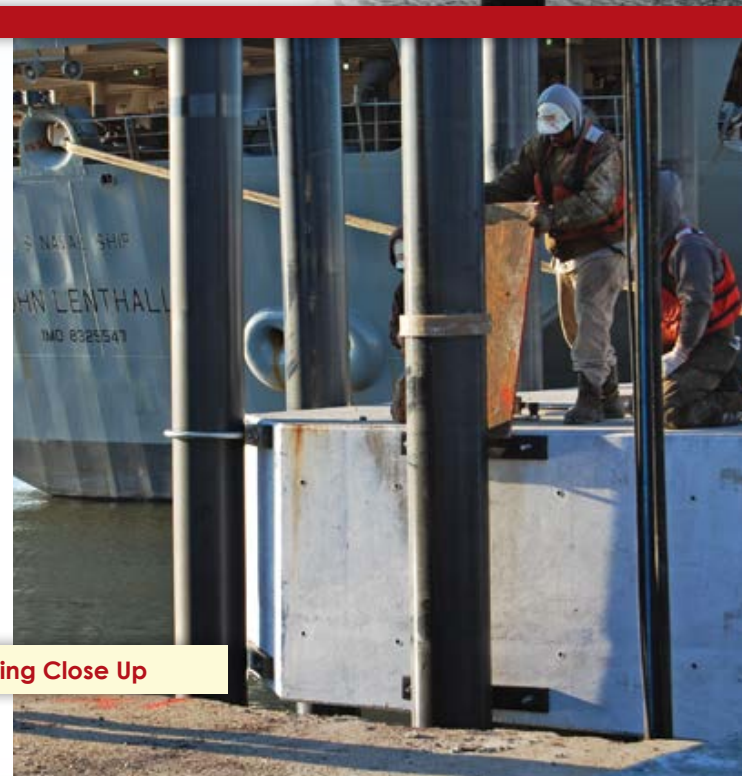

## SLEEVE OPTIONS THICK AND THIN

The thin casing sleeve can be attached to the pipe at the factory and driven as a pile/sleeve assembly. The thick sleeves can be shipped assembled with the pipe pile; however, driving conditions may require that the sleeve be removed from the pile prior to driving and then secured after the pile has been driven. The heavy sleeves are secured with four 3/4" (19mm) bolts and washers placed near the top of the pile.



**Thick Wall Sleeve**

An alternative option that has had great success involves CPI attaching an FRP ring to the pile prior to being driven. The FRP ring keeps the sleeve held into position onto the pile while allowing the thick sleeve to spin on the pile when a vessel comes into contact with the pile. This detail allows the vessel to freely rub along side of the pile with less friction and for the HDPE sleeve to grow and contract independently of the FRP pile as the coefficient of thermal expansion of the HDPE sleeve is significantly higher than that of the FRP pile.

## PILE CAP OPTIONS



**Polyethylene Pile Cap**

The round SUPERPILE® can be capped with non structural or structural caps. The cosmetic caps are cone or flat shaped and are strictly cosmetic and intended to keep birds and such from entering the piles. CPI recommends that structural caps be used in areas where people can climb on the piles as the possibility exists that a small child could collapse the thermoplastic cap and fall into the piles. The non structural Polyethylene Pile Cap options are white or black. The sleeve is 2" tall and the cone height is 3-1/2" - 4".

The Polyethylene Pile Cap is UV resistant and has an estimated life of 15 years for black tops and 9 years for white tops. The polyethylene caps should be attached with large head stainless steel self drilling screws that are normally included if caps are purchased through CPI.



**FRP Structural Cap**

The **FRP Structural Cap** is a structural cap that will last indefinitely. It is milled from solid FRP plate, painted black and is attached with stainless steel self drilling screws. The cap will support significant loads and can be used to mount lights and other navigational or marine accessories. The FRP cap matches the pile outside diameter and fits flush with the top of the pile with a protruding insert that fits the interior of the pile. The thickness of the flush top plate is 1/2". The protrusion portion of the FRP pile cap ranges from 3/4" to 1".

The octagonal piles are capped with a low density, UV stabilized polyethylene cap. The UV stabilized polyethylene octagonal caps should be fastened with self drilling stainless steel screws.



**UV Stabilized Polyethylene Top Cap**

## COLOR OPTIONS



The standard color of the FRP pile is black. Custom colors are available upon request. CPI recommends that a UV protection layer be incorporated onto the pile surface if the pile is exposed to UV light and the application is architectural or cosmetic.

The UV protection is available in the form of a paint or polyurethane coating or in the form of a high density polyethylene sleeve.

Polyurethane coatings have an advantage as they provide UV and abrasion protection while exhibiting a textured architectural appearance. Polyurethane and paint coatings are offered in various colors. Consult the factory and talk to a representative to determine the best UV protection option for your installation.

## BEARING AND DOCK PILES

SUPERPILE® is used extensively for bearing pile applications. The SUPERPILE® can be utilized hollow or concrete filled depending on the strength and stiffness requirements for your application.

Engineers and owners are discovering the benefits of using FRP piles in the splash zone. This exercise will significantly increase the service life of your structure.

As an example, after Hurricane Sandy, the Federal Highway Administration (FHWA) replaced the visitor and service docks on Liberty Island, NY with new docks made of FRP and wood. The FHWA engineers specified polymer piles to be used for the bearing piles in order to increase the service life of the structure. The piles were driven to refusal and filled with concrete. The dock structure was erected and the wood plank decking attached.



Visitor Center Reopens



Liberty Island Installation Site



FRP Bearing Piles

Another example of engineers and owners taking advantage of FRP materials involves the construction of an all composite fire boat dock in Jacksonville, Florida. The dock was designed for a category three hurricane direct hit, as the structure is critical for the fire department rescue team.

SUPERPILE® supports the boat lift. The substructure is made of FRP pultruded channels and beams that support the pultruded grating walkway that extends from the firehouse to the boat lifts.



## BEARING AND DOCK PILES

FRP Pultruded Grating Walkway Leading to Dock

Pultex® Standard Structural Channels Support FRP Grating

## COLUMN LOAD CHARTS

The compression capacity of the pultruded piles can be determined based on both short and long column behavior. The ultimate column load shall be determined by the lesser value of the two equations. Euler buckling governs the capacity of the long column poles.

$$F_{cr} = \sigma_c - 1/7 \frac{KL}{r}$$

Where:

- $F_{cr}$  = Critical compression stress
- $\sigma_c$  = Axial compression strength
- $K$  = Effective length factor
- $L$  = Laterally unbraced length of member
- $r$  = Radius of gyration about the axis of buckling

$$F_{cr} = \frac{\pi^2 E}{\left(\frac{KL}{r}\right)^2}$$

Where:

- $F_{cr}$  = Critical compression stress
- $E$  = Modulus of elasticity
- $K$  = Effective length factor
- $L$  = Laterally unbraced length of member
- $r$  = Radius of gyration about the axis of buckling

The column load charts have been set up based on the short and long column equations presented. Reference Pultex® Pultrusion Design Manual. The column height is considered to be the length of the pile, out of the ground, to the applied compression load. The effective length factor "K" is equal to 1 based on pinned-pinned end conditions.

A pultruded column will fail in either short or long column mode. The long column capacity follows Euler buckling and is influenced by the modulus of elasticity and the radius of gyration and the length of the column.

The loads depicted in the column charts are unfactored ultimate load capacities. A safety factor of three is recommended.

## BEARING AND DOCK PILES COLUMN LOAD CHARTS

SUPERPILE® Round Pole Load Chart				
Column Capacity Based on a K=1.0 (Rotation and Translation Fixed)		Ultimate Column Capacity, lb (kg)		
Pole Length, Above Ground, ft	Pole Length, Above Ground, m	Round Pole TU455 12"x3/8"	Round Pole TU450 12"x1/2"	Round Pole TU460 16"x1/2"
40	12.19	52,145 (23,652)	75,906 (34,430)	187,246 (84,934)
42	12.80	47,297 (21,453)	68,849 (31,229)	169,838 (77,037)
44	13.41	43,095 (19,547)	62,732 (28,455)	154,749 (70,193)
46	14.02	39,429 (17,885)	57,396 (26,034)	141,585 (64,222)
48	14.63	36,212 (16,425)	52,712 (23,910)	130,032 (58,982)
50	15.24	33,373 (15,138)	48,580 (22,035)	119,838 (54,357)
52	15.85	30,855 (13,995)	44,915 (20,373)	110,797 (50,257)
54	16.46	28,612 (12,978)	41,649 (18,892)	102,742 (46,603)
56	17.07	26,604 (12,068)	38,727 (17,566)	95,534 (43,333)
58	17.68	24,801 (11,250)	36,103 (16,376)	89,059 (40,396)
60	18.29	23,175 (10,512)	33,736 (15,302)	83,221 (37,748)
62	18.90	21,704 (9,845)	31,594 (14,331)	77,938 (35,352)
64	19.51	20,369 (9,239)	29,651 (13,449)	73,143 (33,177)
66	20.12	19,153 (8,688)	27,881 (12,647)	68,777 (31,197)
68	20.73	18,043 (8,184)	26,265 (11,914)	64,791 (29,389)
70	21.33	17,027 (7,723)	24,786 (11,243)	61,142 (27,733)
72	21.94	***	23,428 (10,627)	57,792 (26,214)
74	22.55	***	22,178 (10,060)	54,710 (24,816)
76	23.16	***	21,026 (9,537)	51,869 (23,527)
78	23.77	***	19,962 (9,055)	49,243 (22,336)
80	24.38	***	18,976 (8,608)	46,812 (21,233)

Octagonal Pole Load Chart				
Column Capacity Based on a K=1.0 (Rotation and Translation Fixed)		Ultimate Column Capacity, lb (kg)		
Pole Length, Above Ground, ft	Pole Length, Above Ground, m	8 in. Series II CP076	10 in. Series II CP074	10 in. Series III CP210
22	6.71	37,119 (16,837)	78,990 (35,829)	89,950 (40,800)
24	7.31	31,190 (14,148)	66,373 (30,106)	75,583 (34,284)
26	7.92	26,576 (12,055)	56,555 (25,653)	64,402 (29,212)
28	8.53	22,915 (10,394)	48,764 (22,119)	55,530 (25,188)
30	9.14	19,962 (9,054)	42,479 (19,268)	48,373 (21,942)
32	9.75	17,544 (7,958)	37,335 (16,935)	42,515 (19,285)
34	10.36	15,541 (7,049)	33,072 (15,001)	37,661 (17,083)
36	10.97	13,862 (6,288)	29,499 (13,381)	33,592 (15,237)
38	11.58	12,441 (5,643)	26,476 (12,009)	30,149 (13,676)
40	12.19	11,228 (5,093)	23,894 (10,838)	27,210 (12,342)
42	12.80	10,184 (4,620)	21,673 (9,831)	24,680 (11,195)
44	13.41	9,280 (4,209)	19,747 (8,957)	22,487 (10,200)
46	14.02	8,490 (3,851)	18,068 (8,195)	20,575 (9,332)
48	14.63	7,797 (3,537)	16,593 (7,527)	18,896 (8,571)
50	15.24	7,186 (3,260)	15,292 (6,937)	17,414 (7,899)

## BEARING AND DOCK PILES

### CONCRETE FILLED PILES

SUPERPILE® can be filled with concrete. Most contractors have chosen to drive the pile hollow and then pump the pile full of concrete. Concrete increases the transverse crush strength, bending strength and lengthwise compression strength. Full section testing performed on the 16" diameter pile with 3,800 psi concrete resulted in a 40% increase in bending stiffness and a 50% increase in strength. Note that the pile was not tested to failure. It was

tested to a load of 150 kips due to limitations of the test equipment.

The concrete filled 16" SUPERPILE® was tested to determine the crush strength. The pipe pile was loaded by applying a crush load through a 10" square thermoplastic wale section. The load was applied until the predetermined limit of 180 kips was obtained. The pile showed no signs of distress.



Crush Test on Concrete Filled Pile



Full Section Testing of Concrete Filled Pile



Piles with Driving Tips Ready to Ship

### DRIVING TIPS

Driving tips are available for the 12" and 16" pipe piles. The cast steel driving tips are conical and are attached to the pile at the production plant. They offer bearing resistance and permit the piles to be concrete filled in situ.

## INSTALLATION METHODS

### VIBRATORY HAMMER

SUPERPILE® can be efficiently driven with a vibratory hammer. When utilizing a vibratory hammer, an adaptor shall be fabricated to connect the pile to the vibratory hammer. The adaptor shall include an interior steel pipe that fits into the SUPERPILE® to guide the pile. The interior tube should be between 0.5" and 2" of the interior diameter of the FRP pile. The interior pipe shall be welded onto a flat steel plate. The steel plate will apply the compression force into the top of the pile. The steel plate shall be connected to a beam that can be clamped by the vibratory hammer.

The contractor is cautioned that, on some occasions, the pile may require an FRP insert for added compression or pin bearing strength. Therefore, the interior diameter of the pile will change. The contractor should base the vibratory adaptor fabrication on the approved pile drawings.

In the event that a pile needs to be pulled, a vibratory hammer can be utilized to pull the piles. Through bolt the pile and the drive head with three 1" diameter bolts spaced a minimum of 5" apart. Vibrate the pile and pull tension until the pile begins to move. Once the friction has broken, pull the pile without the vibratory hammer engaged. The vibratory hammer oscillation will cause the bolt holes to elongate if engaged for an extended period of time.



Example of Vibratory Hammer Steel Fabrication



HAMMER	V-5C	
DRIVING FORCE	53 tons	472 kN
FREQUENCY	1,700 CPM	
ECCENTRIC MOMENT	1,300 in.-lbs.	1,500 kg-cm
AMPLITUDE	1 in.	25.4 mm
CLAMPING FORCE	62 tons	550 kN
MAX. LINE PULL	30 tons	267 kN
HEIGHT	91 in.	2,311 mm
THROAT WIDTH	13 in.	330 mm
SHIPPING WIDTH	79 in.	2,007 mm
WEIGHT W/ CLAMP	7,200 lbs.	3,276 kg
HOSE BUNDLE LENGTH	100 ft.	30 m

Typical Vibratory Drive Hammer Specifications (Courtesy of RPI Construction Equipment)

**IMPORTANT NOTICE:** In reference to the proper use of this equipment, please be advised that job site conditions may vary due to a change in the geology of a particular area. It is always a good practice to consult with a geotechnical engineer prior to starting a project. Also, a good rule of thumb is to know your soil conditions before selecting pile driving equipment. This can be accomplished by reviewing test soil borings before every project. The above equipment is being used in a granular soil condition which is recommended when using vibratory driver / extractors.

~ RPI Construction Equipment

## INSTALLATION METHODS

### AIR AND DIESEL IMPACT DRIVING HAMMERS

Diesel and air impact hammers have been successfully utilized to drive install the 12" and 16" diameter SUPERPILE®. A pipe insert driving head or steel pipe cap is required for driving the hollow FRP piles. It is important that the piles are impacted so that the driving force is dissipated over the cross section of the top of the pile. A plywood or composite material pile cushion can also be utilized to reduce driving stresses induced into the pile.



Vulcan 01 Impact Hammer Driving 16" Diameter SUPERPILE®



Example of Pipe Insert Driving Head for Driving Hollow Piles

## PDA ANALYSIS

Dynamic Pile Testing (PDA) has been successfully performed on SUPERPILE® in the Coastal Plain soils of Virginia. CPI contracted to Crofton Construction Services, Inc. and to Atlantic Coast Engineering for installation of SUPERPILE® by impact driving and to perform PDA analysis in order to have a Pile Dynamic Analysis (PDA) performed on SUPERPILE®.

Crofton Construction Services, Inc. installed two SUPERPILE® in Norfolk, Virginia. The first test pile was installed with a Vulcan 01 Impact Hammer and the second with an APE D30-32 Impact Hammer. Both piles were driven with a closed-end steel toe plate bolted to the bottom of the pile in order to increase the driving resistance of the soils. The pile driven with the Vulcan 01 Air Hammer was driven to refusal (120 blows/ft.) at a depth of 35 feet and then extracted for visual inspection. The pile driven with the APE D30-32 Impact Hammer was driven to a depth of 50 feet, allowed to set overnight, and was re-driven on the following date with dynamic test gauges attached to the pileday and dynamically monitored by Atlantic Coast Engineering.

Testing was performed to aid contractors in the selection of the appropriate impact hammers for installation of the SUPERPILE®. And, to establish, for Geotechnical Engineers, the feasible soil resistances in which the piles may be driven without damage and to identify the allowable driving stress.

The rated capacity of each hammer is utilized in the PDA as follows:

Hammer	Rated Driving Energy	Typical Energy Expected to be Delivered to Pile
Vulcan 01	15 kip-ft	6-9 kip-ft
APE D30-32	74 kip-ft	20-40 kip-ft

## PDA ANALYSIS

The test pile driven with the Vulcan 01 Impact Hammer, to refusal, demonstrated a driving resistance of 160 kips, a driving energy of 8 kip-ft., and a compressive driving stress of 8 ksi. The pile was extracted, inspected and revealed no signs of damage.

The test pile driven with the larger APE D30-32 Impact Hammer was driven through the same soils at a blowcount of 9 blows/ft. ending at a blowcount of 12 blows/ft., which was evaluated to represent a resistance of 200 kips with a compressive stress of 11 ksi. No evidence of damage was observed.

After a one day set up period, the pile was re-driven with the APE D30-32 Impact Hammer at a substantially greater resistance. At 235 blows/ft., a driving resistance of 340-370 kips, an average energy transfer of 30 ksi and a recorded compressive driving stress of 13-15 ksi, the pile head split and the pile failed. Prior to the pile head splitting, a CAPWAP® analysis indicated an ultimate axial compressive capacity of 350 kips.

The PDA testing indicates that impact hammers with a rated energy of 15 to 35 kip-ft are appropriate for the installation of SUPERPILE®.

Hammers with rated energies in the range of 35 to 50 kip-ft should be used with some level of caution, and may require a pile cushion to reduce driving stresses.

Based on observations made during the test pile program, it is recommended that Dynamic Consultants utilize a model PAX PDA unit (with a longer pretrigger buffer than the PAK unit) due to the longer pre-compression time.

For impact and vibratory installed SUPERPILE®, CPI recommends the use of a Wave-Equation Analysis and Driveability Study to assess the soil-pile interaction and estimate pile driving stresses during installation considering the proposed hammer assembly and site soil profile.



PDA Analysis - Crofton Yard

## CUTTING AND DRILLING INSTRUCTIONS

### CUTTING PILES



Concrete Saw

SUPERPILE® can be field cut with a concrete, skill or reciprocating saw. An abrasive blade should always be used. Concrete saws work the best and can be utilized with a standard concrete cutting blade. During drill and sawing operations, dust will be emitted. The dust is considered a nuisance dust, which can irritate your eyes and skin. Therefore, safety glasses, gloves and long sleeve shirts are recommended during the cutting and drilling process.

As documented by OSHA, FRP dust millings have potential to cause eye, skin, and upper respiratory tract irritation.

- Cause - mechanical-irritant properties of the glass fibers.
- FRP particulate is non-hazardous.
- FRP particulate is greater than 6 microns; therefore, it cannot reach the alveoli.
- The International Agency for Research on Cancer (IARC) classified FRP particulate as non-cancer causing in June of 1987.

## DRILLING PILES

SUPERPILE® can be drilled with carbide tipped drill bits. CPI recommends B & A Manufacturing Company (<http://www.bamanufacturing.com>) FGH series drill bits for applications that require multiple holes in a short period of time. Many contractors and utilities have had success when utilizing the FGH series drill bits. The bits will save time and drill thousands of holes before needing to be replaced.



FCH Series Fiberglass Pile Driving Bit

## PROPER HANDLING UPON DELIVERY

Proper care should be taken during handling. The piles were packaged and loaded on the flatbed with a tow motor. Contact CPI for the weights of the piles and individual packages.

Proper care should be taken when removing the tie-down straps. Although the piles are cradled in wood chocks, never assume that the wood chocks will keep the piles from shifting.

The pultruded piles are smooth and can be very slippery if they become wet. Never use steel chokers or chains to unload the piles. A nylon strap, preferably with a neoprene skin is recommended. This will reduce the chance of the pile sliding during the picking process. CPI prefers to use light pole handling slings, made by Lift-It® (<http://www.lift-it.com>). The slings must be double wrapped and the manufacturer's recommendations must be followed.



Lift-It® Sling Double Wrapped Around SUPERPILE®

## VISUAL INSPECTION UPON DELIVERY

Upon delivery of the piles, the piles shall be inspected for damage that could affect the long term performance of the piles. Normal wear and tear including abrasions and scuff marks are common and shall not cause concern.

The piles are manufactured to the most current version of ASTM D4385. ASTM D4385 is a pultrusion industry recognized visual specification and can be used for inspection of the piles during delivery or at the plant.

## SHIPPING AND RECEIVING

SUPERPILE® is shipped to the job site via flatbed dedicated truck. The continuous manufacturing process permits Creative Pultrusions, Inc. (CPI) to manufacture piles to long lengths eliminating the need for splices.

Prior to shipping, the contractor shall communicate with CPI regarding the packaging and shipping method. Considerations shall include but may not be limited to:

- Length of piles
- Quantity of piles on the truck
- Weight of the pile packages
- Unloading method



Dedicated Truck Hauling 80' Piles to Margate, New Jersey

## SUPERPILE® SPECIFICATION

This specification is intended to define pultruded FRP pipe piles for procurement purposes.

### 1.0 SCOPE

- 1.1 This specification applies to the material requirements, the manufacture and performance of fiber reinforced polymer piles.
- 1.2 The mechanical properties shall be published per ASTM D7290.

### 2.0 MATERIAL DESIGN

- 2.1 The pultruded pipe pile shall be manufactured by the pultrusion process using a polymer binder containing a minimum 52% "E-CR" or "E" fiberglass by volume. Glass volume shall be 47% in the lengthwise direction and 14% in the crosswise direction.
- 2.2 E-glass reinforcements shall meet a minimum tensile strength of 290 ksi per ASTM D2343.
- 2.3 The octagonal pipe piles shall be pultruded with a high performance Vinyl Ester (VE) resin that is based on a bisphenol-A epoxy matrix. The VE resin shall be utilized for its superior toughness and fatigue attributes. The VE resin provides fire retardant properties that permit the pole to "self extinguish" in the event of a brush fire. Poles shall be classified as "self extinguishing" per UL94 with a V0 rating. The flame spread shall be class I per ASTM E-84 with a Flame Spread Index (FSI) of 25 or less.
- 2.4 The round pipe piles shall be manufactured with a low Volatile Organic Compound (VOC) two component polyol/isocyanate polyurethane matrix with a minimum resin content of 47%.
- 2.5 The piles shall contain Ultra Violet (UV) protection as a long term thermal and light stability promoter. Second, the fiberglass piles shall be encompassed with a 10 mil polyester surfacing veil. The 10 mil veil shall create a resin rich surface and protect the glass reinforcements from fiber blooming.

### 3.0 STRENGTH & STIFFNESS PROPERTIES

- 3.1 The octagonal pipe pile strength and stiffness values shall be derived per ASTM D1036.
- 3.2 The round pipe pile characteristic strength and stiffness values shall be derived per ASTM D6109.

### 4.0 FINISH

- 4.1 The surface of the pile shall contain a UV resistant, resin rich, smooth and aesthetically pleasing finish uniform along the entire pile length. The piles shall be manufactured and visually inspected in accordance with ASTM D4385.

## SUPERPILE® SPECIFICATION

### 5.0 MANUFACTURING TOLERANCES

- 5.1 Pile Length ( $\pm 2''$ ) or 50 mm
  - 5.1.1 Squareness of end cut ( $1/4''$ ) or 6.35 mm.
  - 5.1.2 Pile profile dimensions per ASTM D 3917.
  - 5.1.3 Straightness: 0.030"/ft. (2.5mm/m) with weight minimizing.
  - 5.1.4 Weight: +/- 10%.

### 6.0 SHIPPING

- 6.1 Crated piles shall be individually protected in cardboard or equivalent protective material in areas in which dunnage makes contact with piles.
- 6.2 Piles shall be crated in bundles for ease of handling and transfer without damage to the piles by lift equipment.

### 7.0 QUALITY ASSURANCE

- 7.1 Quality Assurance shall be performed as described in the organizations quality plan, as approved by the Engineer of Record.

## IDENTIFICATION TAGS

Identification Tags, when required by the customer, are supplied by CPI.

Standard tags are made of 304 dull stainless, 1" x 3.5" x .015" in size with two .250" holes for riveting to the pile.

The tag is embossed with information, including the manufacturing month and year, the pile part number and a serial number, specific to the application. The information is documented for future reference.

○ CREATIVE PULTRUSIONS, INC  
○ MADE IN USA MFG MO/YR  
ID: TU455-0000

# Appendix A - 18"x 3/4" Pile Properties

Description	Round FRP Pipe Pile TU465 Polyurethane 18"x3/4" Metric (457mmx19mm)
<b>SuperPile Mechanical Properties</b>	
Average Flexural Strength per ASTM D6109 psi (Mpa)	53,470 (369)
Characteristic Flexural Strength per ASTM D6109 psi (Mpa)	42,110 (290)
Average Compression Strength per ASTM D6109 psi (Mpa)	53,470 (369)
Characteristic Compression Strength per ASTM D6109 psi (Mpa)	42,110 (290)
Average In-Plane Shear Strength psi (Mpa)*	17,170 (118)
Characteristic In-Plane Shear Strength psi (Mpa)*	14,936 (103)
Average Shear Capacity lbs (Kg)*	348,894 (158,256)
Characteristic Shear Capacity lbs (Kg)*	303,500 (137,665)
Average Torque Strength lb-ft (kN·m)*	501,589 (680)
Characteristic Torque Strength lb-ft (kN·m)*	436,327 (592)
Average Axial Compression Strength psi (Mpa)	53,470 (369)
Characteristic Axial Compression Strength psi (Mpa)	42,110 (290)
Average Axial Compression Capacity (Short Column) lb (kg)	2,173,021 (985,666)
Characteristic Axial Compression Capacity (Short Column) lb (kg)	1,711,350 (776,256)
Average Modulus of Elasticity per ASTM D6109 psi (Gpa)	5.19E+06 (35.8)
Bending Stiffness (EI) per ASTM D6109 lbs·in <sup>2</sup> (kg·mm <sup>2</sup> )	7.86E+09 2.30E+12
Average Moment Capacity per ASTM D6109 kip-ft (kN·m)	750 (1,017)
Characteristic Moment Capacity per ASTM D6109 kip-ft (kN·m)	591 (801)
Average Energy Absorption kip-in (kN·m)	1290 (146)
Characteristic Energy Absorption kip-in (kN·m)	730 (82)
Average Pin Bearing Strength Crosswise psi (Mpa)*	23,666 (163)
Characteristic Pin Bearing Strength Crosswise psi (Mpa)*	20,771 (143)
Average Pin Bearing Strength Lengthwise psi (Mpa)*	27,788 (192)
Characteristic Pin Bearing Strength Lengthwise psi (Mpa)*	19,217 (133)
Average Pile Crush Strength lb (kg) (based on a 9" wide load path) <sup>1*</sup>	16,600 (7,530)
Characteristic Pile Crush Strength lb (kg) (based on a 9" wide load path) <sup>1*</sup>	11,667 (5,292)
Average Crush Strength, with FRP Insert, lb (kg) (based on a 9" wide load path) <sup>1*</sup>	44,213 (20,055)
Characteristic Crush Strength, with FRP Insert, lb (kg) (based on a 9" wide load path) <sup>1,2*</sup>	*****
Average Washer Pull Through Strength lb (kg) using a 6"x1/2" square/radius washer*	27,582 (12,511)
Characteristic Washer Pull Through Strength lb (kg) using a 6"x1/2" square/radius washer*	25,103 (11,387)
Average Washer Pull Through Strength lb (kg) using a 6"x3/8" square/radius washer*	18,878 (8,563)
Characteristic Washer Pull Through Strength lb (kg) using a 6"x3/8" square/radius washer*	13,521 (6,133)
Allowable torque permitted on a bolted connection with a 6" radius washer lb-ft (N·m)	50 (68)
<b>Physical Properties</b>	
Diameter in (cm)	18 (45.72)
Wall thickness in (mm)	0.75 (19.1)
Moment of Inertia in <sup>4</sup> (cm <sup>4</sup> )	1514 (63,017)
Section Modulus in <sup>3</sup> (cm <sup>3</sup> )	168.3 (2,758)
Radius of Gyration in (mm)	6.1 (155)
Weight lb/ft (Kg/m)	38 (56.5)
Coefficient of Thermal Expansion (CTE) Lengthwise in/in <sup>2</sup> F (mm/mm <sup>2</sup> C)	5.00E-06 (9.00E-06)
Water Absorption ASTM D570	0.15% (24hrs) 0.15% (24hrs)
Fiber Volume Fraction %	≥50% ≥50%
Cross Sectional Area in <sup>2</sup> (cm <sup>2</sup> )	40.64 (262.2)
Surface Area ft <sup>2</sup> /ft (m <sup>2</sup> /m)	4.71 (1.44)

\* THEORETICAL VALUES

<sup>1</sup>The crush strength value is based on full section testing. The strength value was recorded at the first audible sound and change in the load deflection curve. The ultimate capacity is approximately 60% higher and is defined as the highest recorded load documented during the crush strength test.

<sup>2</sup>Characteristic data is unavailable due to the number of tests required. A minimum of 10 tests are required to generate the ASTM D7290 characteristic values.

# Appendix B



Constructed Facilities Center  
Morgantown, WV 26506-6103  
(304) 293-7608



## TEST REPORT

### BENDING AND JOINT RESPONSE OF PILES

16 INCH DIAMETER 1/2 INCH THICK POLYURETHANE

16 INCH DIAMETER 1/2 INCH THICK VINYL ESTER

12 INCH DIAMETER 1/2 INCH THICK POLYURETHANE

PREPARED BY:

  
HOTA GANGARAO, Ph.D., PE

  
MARK SKIDMORE, PE

  
DENNY DISPENNETTE  
*West Virginia University*

SUBMITTED TO:

DUSTIN TROUTMAN  
*Creative Pultrusions, Inc.*  
*214 Industrial Lane*  
*Alum Bank, PA 15521*

8/11/2011

Revised 11/8/2011

---

## 1 INTRODUCTION

---

Creative Pultrusions Inc. has requested WVU-CFC to test piles of circular sections. Two different sets of materials (Polyurethane and Vinyl Ester) were tested, and the test methods used and test data are conveyed in this report. The tests done were four point bending under static load to failure, four point bending fatigue, crush strength test, and two different connection tests. The three types of test specimens consisted of 16 inch diameter ½ in thick vinyl ester samples, 16 inch ½ in thick polyurethane samples, and 12 inch diameter ½ in thick polyurethane samples.

---

## 2 TEST METHODOLOGY

---

### 1. Four-Point Bending Tests

Five piles of each material set were supplied by Creative Pultrusions, Inc to the West Virginia University Constructed Facilities Center on June 2010 for a variety of tests including four-point bending tests. The tests were conducted during July and early August as per ASTM D6109 and Creative Pultrusion's test protocol. The 12 inch piles were setup with a clear span of 240-inches out of a total length of 288-inches, with the load span equal to 1/3<sup>rd</sup> of the clear span or 80-inches. The samples were supported and loaded by using 8-inch long steel saddles that covered slightly less than half of the circumference as shown in Figure 1. The 16 inch piles were set up similarly with the clear span being 320 inches and the load span equal to 1/3<sup>rd</sup> of the clear span or 106.67 inches. The saddles were loaded at the midpoint through round steel stock to simulate simply supported conditions, and with neoprene padding between the saddle and pile. All piles tested were instrumented with a Celesco SP3 string pot to measure deflections up to 50 inches and an Omega LC8400-200-200 kip load cell. Vishay strain gages were installed in the longitudinal direction, with additional gages on certain samples for internal investigations. All samples were loaded to failure with a hydraulic actuator controlled by an electric pump, and a few tests were recorded using audio-visual system. Figure 2 shows the four-point bending of a 16-inch sample, which is identical to the 12-inch testing except for span length.

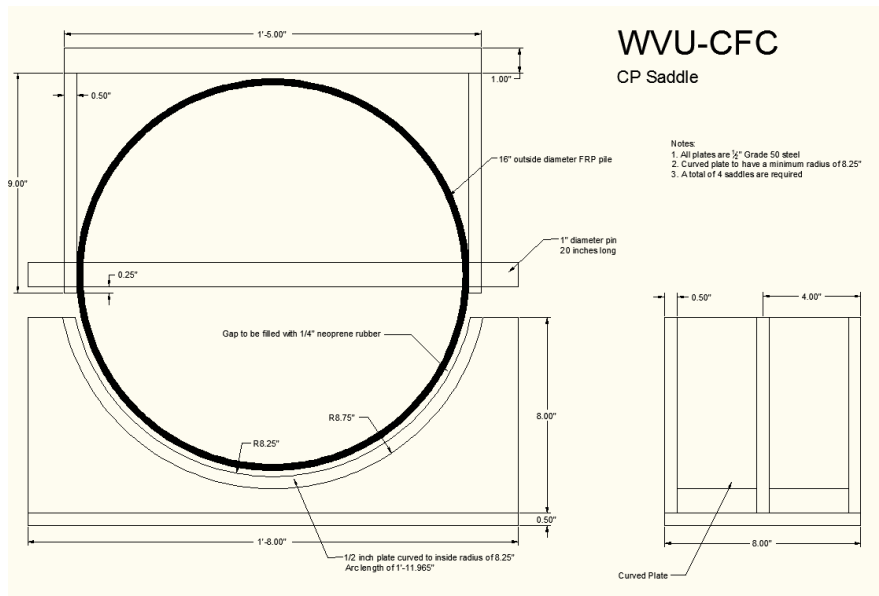

Figure 1: Saddle for testing



Figure 2: Four-Point Bending: 16-inch sample

## 2. Crush Strength Test

Crush testing was conducted on 6 feet sections of the piles supplied by Creative Pultrusions, Inc to the West Virginia University Constructed Facilities Center following their testing under four-point bending. The four-point bending tests led to the failure in the middle (mostly) of the 32-foot long piles, with the ends showing no signs of distress after testing to failure. Therefore the tested piles were cut near the ends to harvest undamaged ends so that they can be used for crush testing. The samples were set in the same saddles used in the four-point bend test with the rollers under the saddles removed. For the 16-inch

piles, the saddles were set at 6-feet apart and the damaged end from four-point testing was left to hang off the end, supported by a gantry crane to keep the specimen level. For the 12-inch piles, 4-foot sections of the piles were cut from the undamaged ends and set in the saddles, with the saddles supporting roughly 4 inches at each end of the pile as shown in Figure 3. For each test, the area between the saddles under the pile was fully supported longitudinally on solid steel plates with neoprene pad between the steel support plate and the FRP composite. Load was applied by a hydraulic actuator controlled by an electric pump. Load was transferred through a steel plate to an Omega LC-8400-200-200 kip load cell and then through another plate into a 10-inch by 10-inch solid polymer wale section that was supplied by Creative Pultrusions, Inc. The wale section was connected to the steel plates by threaded rods for stability during testing. Deflection readings were taken from the wale section by a Celesco SP3 string pot. All test samples were loaded until the area around the application of the load (i.e. top of the pile) failed to the point at which the section was no longer circular and the wale section was nearly touching the sides of the pile. Testing was stopped before the sides were loaded as this caused damage to wale section (cutting into surface of wale section) and additional loading would simply crush flat the already failed structural system.



*Figure 3: Crush Test: 12-inch pile*

### 3. Connection Test A – Transverse Pin Test

A 1” diameter steel pin was inserted through the middle of the 16” and 12” diameter tubes (See Figure 1 and Figure 4). Each tube length was roughly 24”. The load was applied through the 1” diameter pin as shown in Figure 4. The load versus deflection of the pin was recorded at each point that it touched the pipe as shown in Figure 4. Two LVDTs were used directly under the pin on the outside of the load frame (See Figure 4). This positioning yielded accurate deflections and conveys how much the pin hole enlarged during loading to failure. Each specimen with the exception of the first few (Samples 1-3) was loaded until the frame was about to be in contact with the top of the pipe; this was done in order to obtain a good load-deflection curve with many points beyond the maximum load resistance offered by the tube.

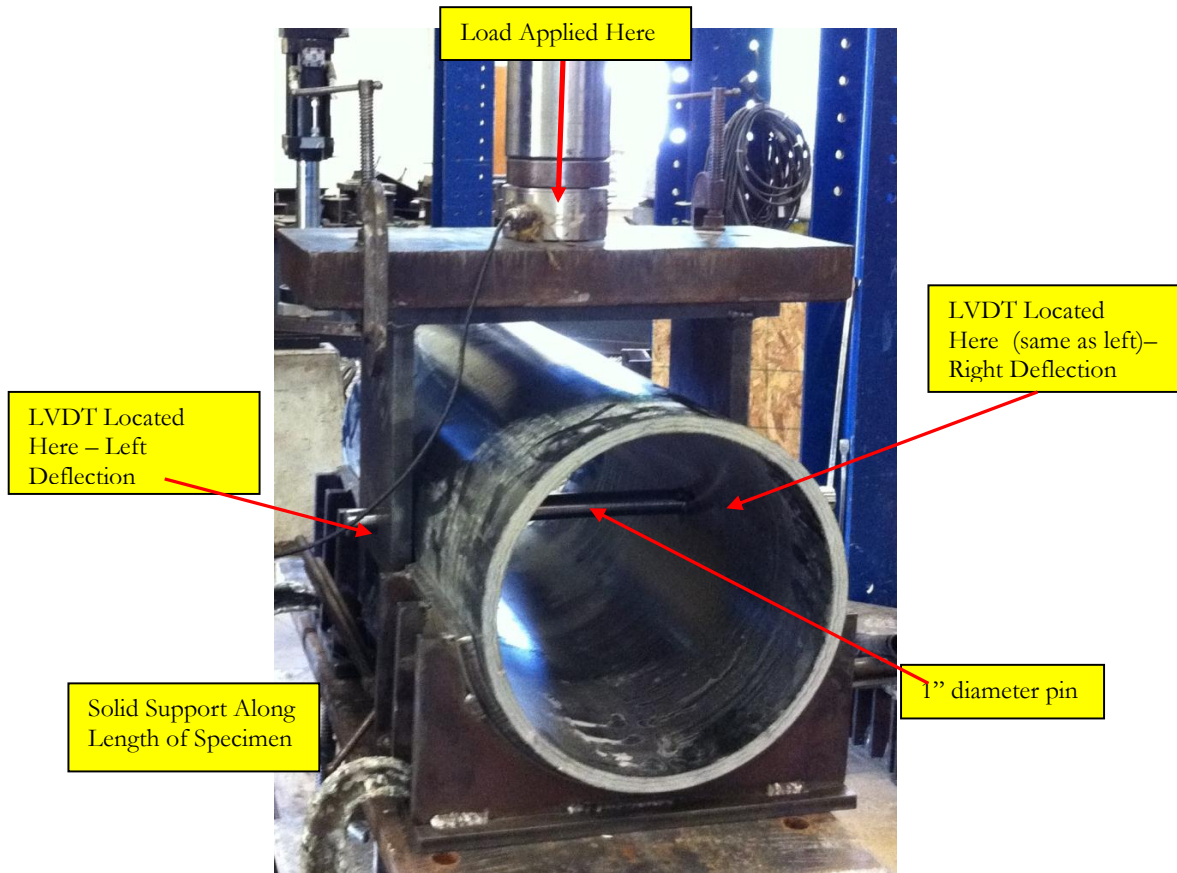

Figure 4: Connection Test A Setup

#### 4. Connection Test B – Washer Test

This testing includes two different sized washers. The load – deflection data reveals the response of the composite piles under a point load over the washer. A bolt hole of 1 inch diameter was drilled straight through sections of the samples (same as Connection Test A). In this test however, a bolt and a washer that were provided by Creative Pultrusions were placed through the hole (See Figure 5). Two different sizes of washers were tested on test samples with three repetitions, except two repetitions in the 16 inch polyurethane pipe with a 6 inch washer. A 4” x 4” washer and a 6” x 6” were used, and these washers were curved to the fit the piles better (See Figure 5). The span lengths used for the 12” and 16” diameter samples were 5’ and 6’ respectively. In all test specimens, 6 inches of overhang was provided beyond the support.

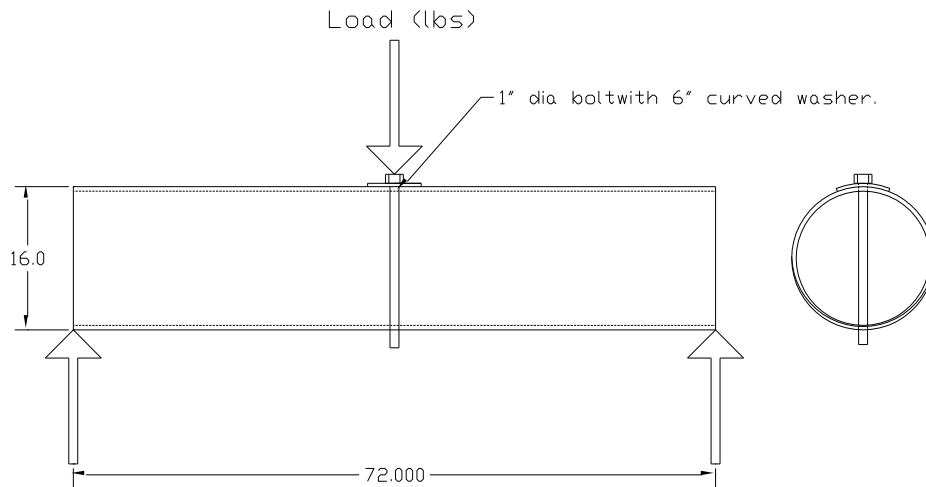

Figure 5: Connection Test B Setup

#### 5. Four-Point Bending Fatigue

One sample of each material was tested in bending fatigue. Using the same test setup for four-point bending as described above, each sample underwent 200 cycles of approximately 40% of its respective average maximum load. It should be noted that a cycle consisted of roughly a 2 kip minimum load and a maximum load of 40% of the failure load. The values actually achieved by the fatigue loading system were slightly different and are recorded as shown in Table 8. At a rate of loading of .075 Hz (cycle/sec), each test endured 44 minutes to attain 200 cycles. This was chosen because of the MTS fatigue actuator’s ability to run smoothly at this rate of loading. The machine used was an MTS Teststar Controller with a maximum compression load of 330 kips. It contains an internal load cell which was calibrated in February 2011 by MTS.

---

### 3 EXPERIMENTAL RESULTS

---

#### 1. Four Point Bending – 12-inch Samples

The results from the 4-point bending tests are given in Table 1. Cracking sounds were clearly heard on all samples starting around 70 kips and continued regularly until failure though no cracks were visible from a safe viewing distance. Failure in all samples was sudden and abrupt, though preceded by much crackling. After failure, longitudinal cracks were found on the pile primarily centering about midspan along with crushing and tearing of the section in the middle third zone of a test specimen. *Sample numbers refer only to the order in which they were tested, and they are not sequenced between different test setups.*

Table 1: 12 inch Four-Point Bending Results

Sample	Max Load (kip)	Max Deflection (in)	Max Moment (kip-in)	Max Stress (ksi)	Max Longitudinal Strain ( $\mu\epsilon$ )	Elastic Modulus (Msi)	Energy (load*defl) (kip-in)
1	93.55	13.42	3742	75.04	13206	6.65	705.06
2	100.35	13.78	4014	80.50	13325	6.62	780.86
3	80.36	11.03	3215	64.46	9657	7.06	489.02
4	87.76	11.39	3510	70.40	11584	6.24	566.15
5	92.61	12.35	3704	74.29	15829	6.47	631.48
<b>Average</b>	<b>90.93</b>	<b>12.39</b>	<b>3637.04</b>	<b>72.94</b>	<b>12720.14</b>	<b>6.61</b>	<b>634.51</b>

The load-deflection responses for all samples are shown in Figure 6.

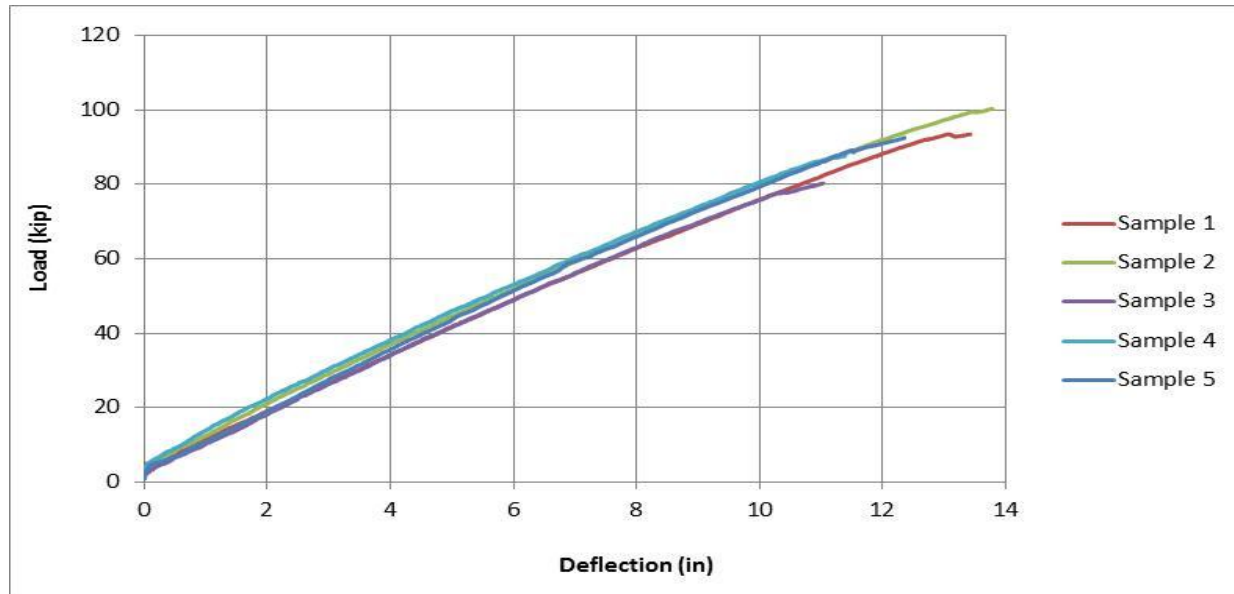

Figure 6: 12 inch Four-Point Bend Load-Deflection Response

## 2. Four Point Bending – 16 inch Polyurethane Samples

The results from the 4-point bending tests of the 16 inch Polyurethane samples are given in Table 2. Cracking sounds were clearly heard on all at around 75 kips though no cracks were visible from a safe viewing distance. Failure in all samples was sudden and abrupt with the load dropping to zero in roughly 0.2 seconds. After failure, longitudinal cracks were found on the pile centered about midspan along with crushing and tearing of the section at midspan. All samples failed in the middle third zone of the test span. *Sample numbers refer only to the order in which they were tested, and they are not sequenced between different test setups.*

Table 2: 16 inch Polyurethane Four-Point Bending Results

Sample	Max Load (kip)	Max Deflection (in)	Max Moment (kip-in)	Max Stress (ksi)	Max Longitudinal Strain ( $\mu\epsilon$ )	Elastic Modulus (Msi)	Energy (load*defl) (kip-in)
1	101.18	16.39	5393	58.9	11137	5.79	944.45
2	100.29	16.88	5346	58.4	12122	5.51	938.47
3	101.58	-	5414	59.2	11794	5.42	-
4	104.42	-	5566	60.8	10109	6.16	-
5	95.69	-	5100	55.7	11265	5.87	-
<b>Average</b>	<b>100.63</b>	<b>16.64</b>	<b>5364</b>	<b>58.62</b>	<b>11285</b>	<b>5.75</b>	<b>941.46</b>

The load-deflection response for all samples is shown in Figure 7.

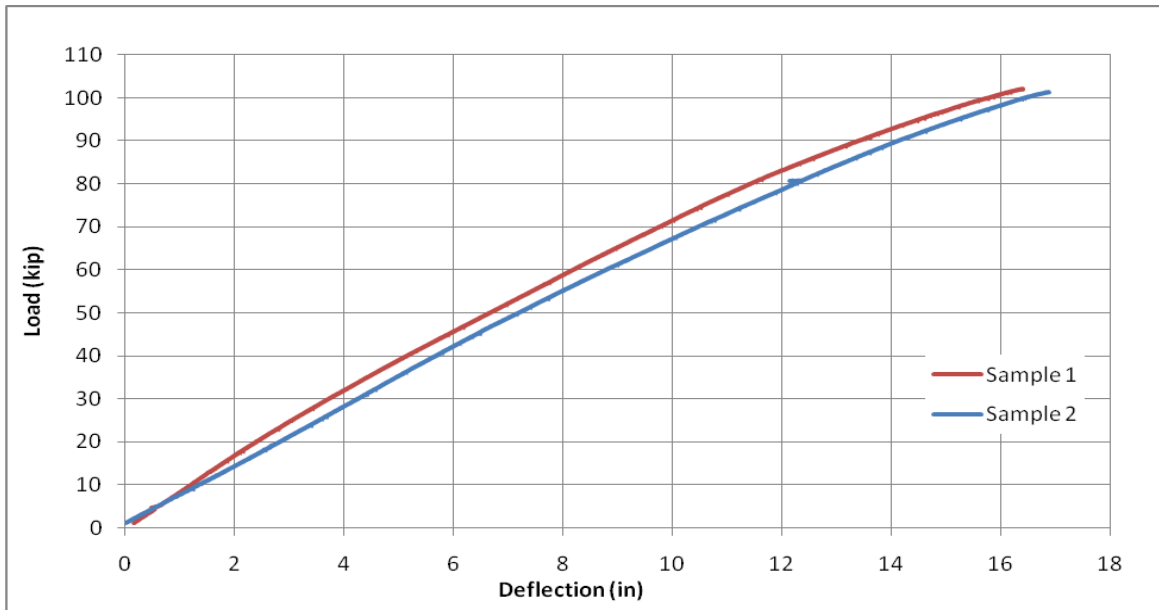

Figure 7: 16 inch Polyurethane Four-Point Bend Load-Deflection Response

### 3. Four Point Bending – 16 inch Vinyl Ester Samples

The results from the 4-point bending tests are given in Table 3. Cracking sounds were not clearly heard on any samples until the applied load was within roughly 5 kips of failure load. No cracks were visible from a safe viewing distance until failure. Failure of all samples was sudden and abrupt with the load dropping to zero in roughly 0.2 seconds. After failure, longitudinal cracks were found on the test specimen centered about midspan along with crushing and tearing of the section at midspan. All samples failed at the center with the exception of Sample 5 which failed under one of the loading saddles. Although neoprene padding was used between the saddles, there is probably some digging of the saddle with the pile near failure loads. It should be noted that the failure results from Sample 5 (Table 3) are very close to the average. *Sample numbers refer only to the order in which they were tested, and they are not sequenced between different test setups.*

Table 3: 16 inch Vinyl Ester Four-Point Bending Results

Sample	Max Load (kip)	Max Deflection (in)	Max Moment (kip-in)	Max Stress (ksi)	Max Longitudinal Strain ( $\mu\epsilon$ )	Elastic Modulus (Msi)	Energy (load*defl) (kip-in)
1	87.41	13.85	4720.31	51.59	9891	5.66	687.45
2	64.53	9.77	3484.60	38.09	7136	5.54	340.97
3	86.70	12.98	4681.57	51.17	9311	5.43	624.76
4	90.31	13.27	4876.61	53.30	9461	5.45	667.60
5	86.35	10.67	4662.86	50.96	8763	5.80	540.74
<b>Average</b>	<b>83.06</b>	<b>12.11</b>	<b>4485</b>	<b>49.02</b>	<b>8913</b>	<b>5.57</b>	<b>572.30</b>

The load-deflection response for all samples is shown in Figure 8.

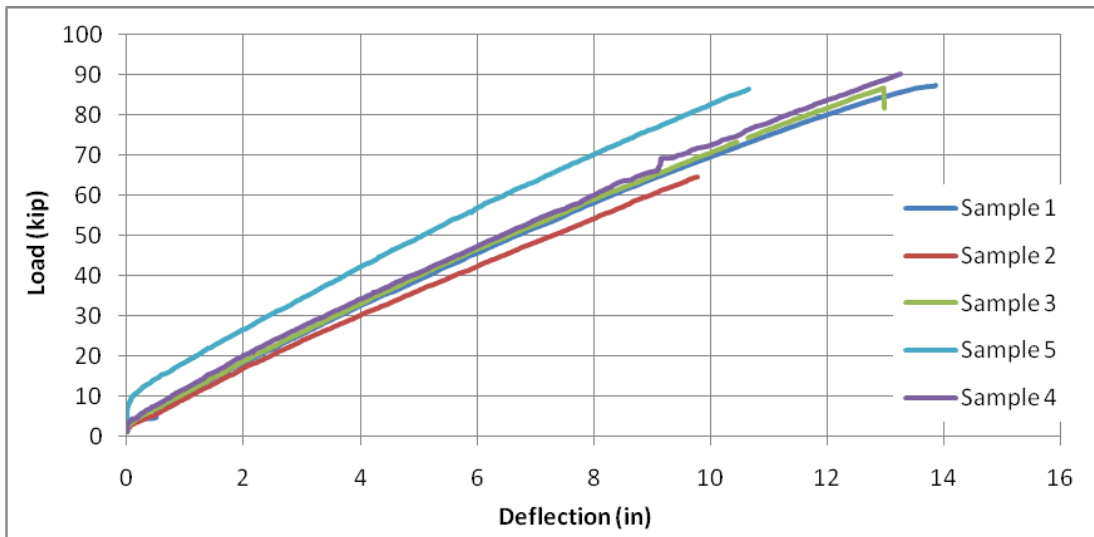

Figure 8: 16 inch Vinyl Ester Four-Point Bend Load-Deflection Response

#### 4. Crush Test – 12-inch Polyurethane Samples

The results from the crush testing are given in Table 4 and Figure 9. Little deflection occurred with the increase in loading until the specimen started crackling, then deflection started to increase quickly. After 2-inches of deflection, the top of the pile had flattened out and longitudinal cracks were visible on both sides, which shows the pile failure but with full failure load on the pile (Figure 10). Upon releasing the load, the pile returned to a circular shape. It should be noted that the ends of the piles remained near

circular in cross section, and no reinforcement effects were visible from the saddles. *Sample numbers refer only to the order in which they were tested, and they are not sequenced between different test setups.*

*Table 4: 12-inch Pile Crush Test Results*

Sample	Maximum Load (kips)	Deflection at Maximum Load (inches)
1	28.05	1.52
2	26.77	1.42
3	25.98	1.3
4	27.91	0.62
5	29.02	1.08
<b>Average</b>	<b>27.54</b>	<b>1.19</b>

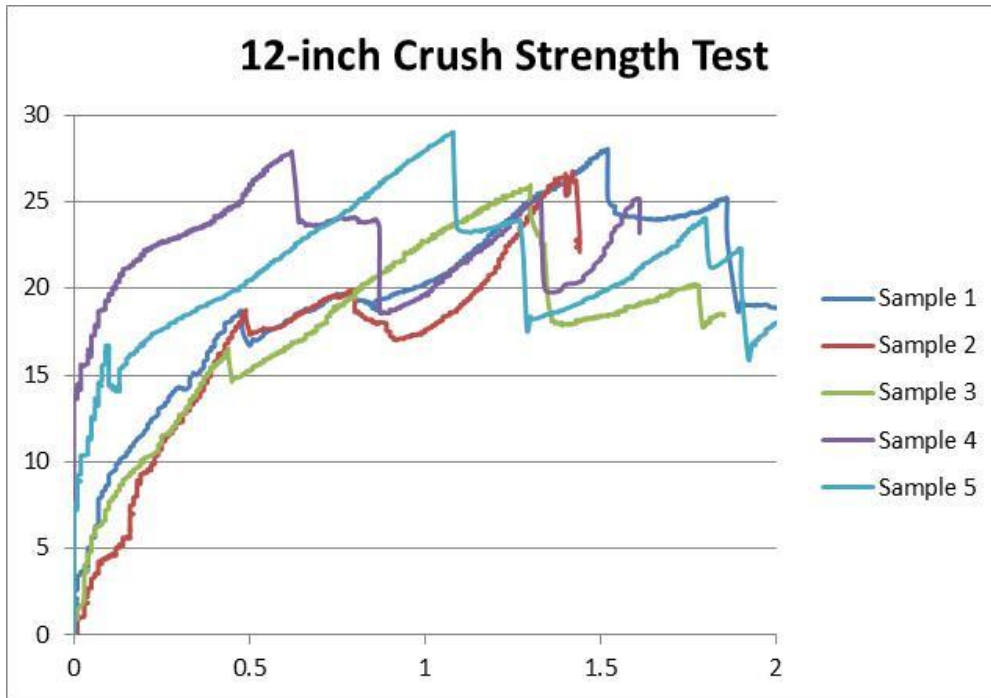

*Figure 9: 12-inch Pile Crush Test Results*



*Figure 10: 12-inch Crush Test Pile Failure*

## **5. Crush Test – 16-inch Polyurethane samples**

The results from the crush testing are given in Table 5 and Figure 11. As with the 12-inch piles, typically there was little deflection induced under vertical loading until the specimen started crackling, then deflection started to grow quickly. After 2-inches of deflection, the top of the pile had flattened out and longitudinal cracks were visible on both sides as shown in Figure 12, which shows a pile at failure but with the full failure load still applied. Upon releasing the load, the pile returned to a circular shape as shown in Figure 13. It should be noted that the ends of the piles remained circular, and no boundary constraint effects were visible from the steel saddles. The string pot used to measure deflection did not work properly for Sample 4, so no deflection readings are available. However, Figure 14 shows the load versus time, which indicates that after the loading to a maximum of 24.59 kips, the total load dropped dramatically which is consistent with the load responses of the other samples. To further investigate if the failure load was peaked when the top flattened out, Sample 2 was loaded beyond this point. As shown in

Figure 15, after the sample passed the reported maximum load of 28.29 kips at 2.28 inches, the load reached a plateau until approximately 3 inches of deflection before picking up additional load of ~23 kips. This approximately corresponds to the location of the longitudinal cracks as seen in Figure 12 and Figure 13. At this point, the load was being primarily supported by the vertical faces of the pile which resulted in the pile cutting into the wale section slightly at these locations. Any further loading would simply crush the sample flat and would not accurately demonstrate its strength. *Sample numbers refer only to the order in which they were tested, and they are not sequenced between different test setups.*

Table 5: 16-inch Polyurethane Crush Strength Results

Sample	Maximum Load (kips)	Deflection at Maximum Load (inches)
1	28.40	1.54
2	29.29	2.28
3	24.86	2.22
4	24.59	N/A
5	30.50	2.037
<b>Average</b>	<b>27.53</b>	<b>2.02</b>

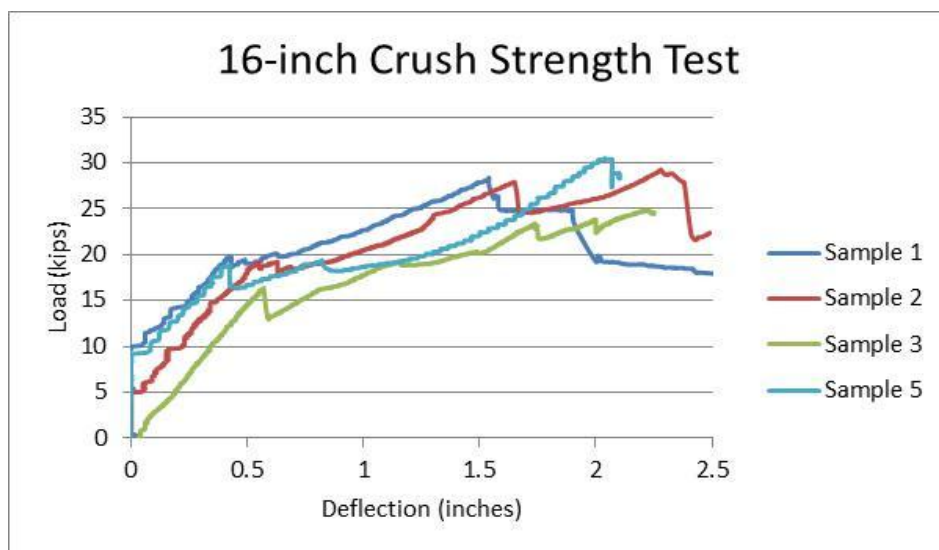

Figure 11: 16-inch Polyurethane Crush Strength Results



*Figure 12: 16-inch Pile Failure Under Load*



*Figure 13: 16-inch Pile at Failure with Load Released*

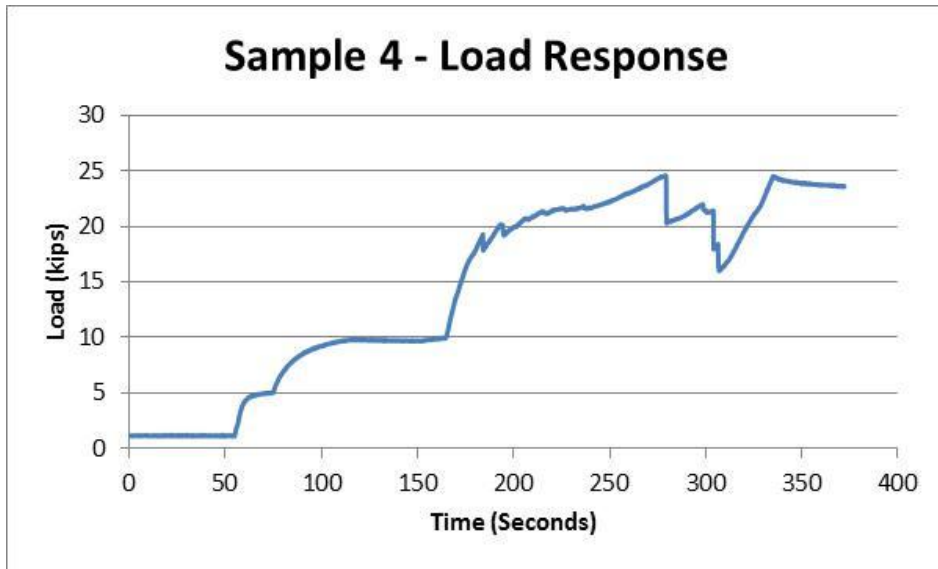

Figure 14: Sample 4 Load Response

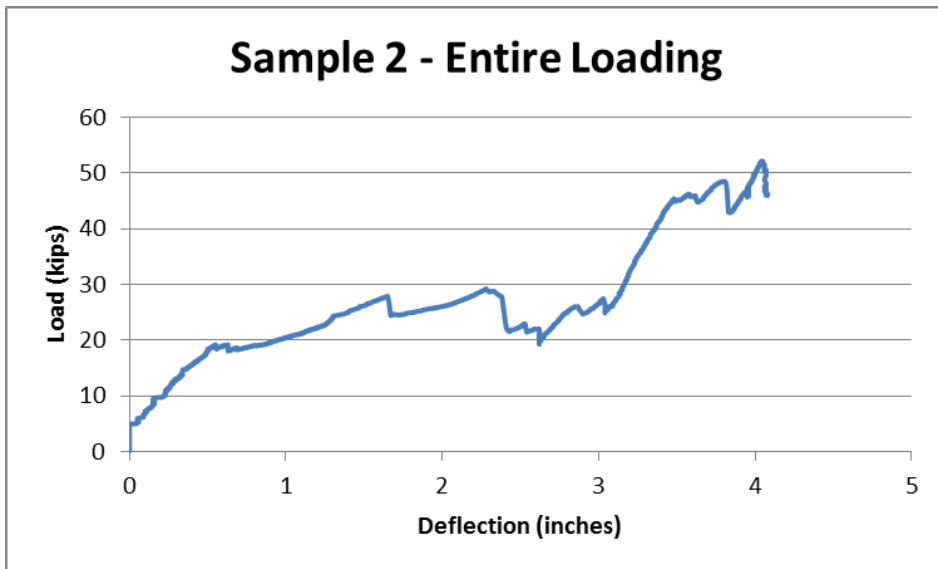

Figure 15: Sample 2 - Entire Loading

## 6. Crush Test – 16-inch Vinyl Ester Samples

The results from the 16-inch vinyl ester samples are very similar to those of the polyurethane. As noted above when the loading block reaches the sides of the cylinder it can take more load, but this was not allowed to happen during these samples. Table 6 provides maximum loads and deflections for all 4 test samples and it's noted that the vinyl ester samples failed at lower loads than polyurethane samples

and deflected less. Of more value though is Figure 16 which shows the load versus deflection results. Each steep drop in loading indicates a cracking/failing of the material, perhaps on a layer by layer basis.

Table 6: 16-inch Vinyl Ester Crush Strength Results

Sample	Maximum Load (kips)	Deflection at Maximum Load (inches)
1	15.34	1.25
2	21.03	2.33
3	22.04	1.53
4	16.58	1.78
<b>Average</b>	<b>18.75</b>	<b>1.72</b>

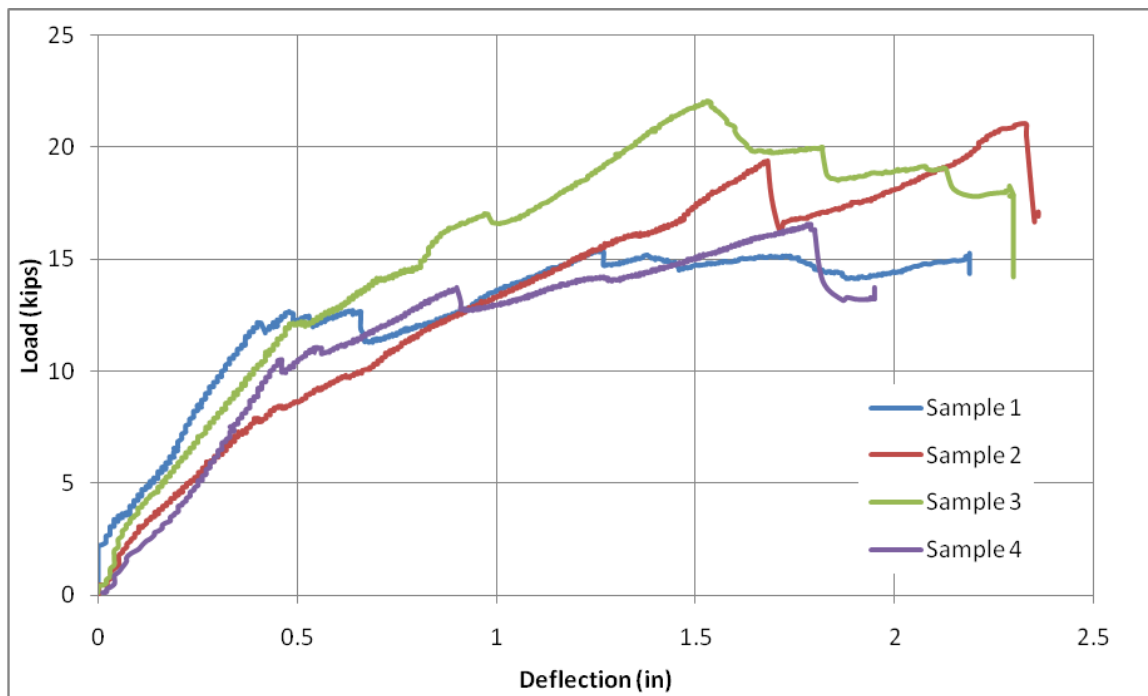

Figure 16: 16-inch Vinyl Ester Crush Strength Results

## 7. Connection Testing A – Transverse Pin Test

For each size and material tested, similar types of load and deflection results were found. Although the maximum loads differ for each material, the behavior was always the same. Eventually the load would not go any higher because the pin deflection was steadily increasing. As opposed to a catastrophic failure characterized by global cracking and delamination as seen in the bending and crush tests, this type of loading seemed to just push its way through the material locally (See Figure 17), i.e., large ductility was noted after initial cracking.



*Figure 17: Typical Failure of Connection Test A*

The load versus deflection curves for each material set are shown in Figures 18 - 20. Sample 1 is not shown because the LVDTs were not working properly and the load was terminated before failure. Also, as mentioned earlier (in methodology section), Samples 1-3 were not loaded as far as others because of setup uncertainties. Right deflection in Sample 4 also had an error at about .58 inches, but every sample tested after the initial ones was without error.

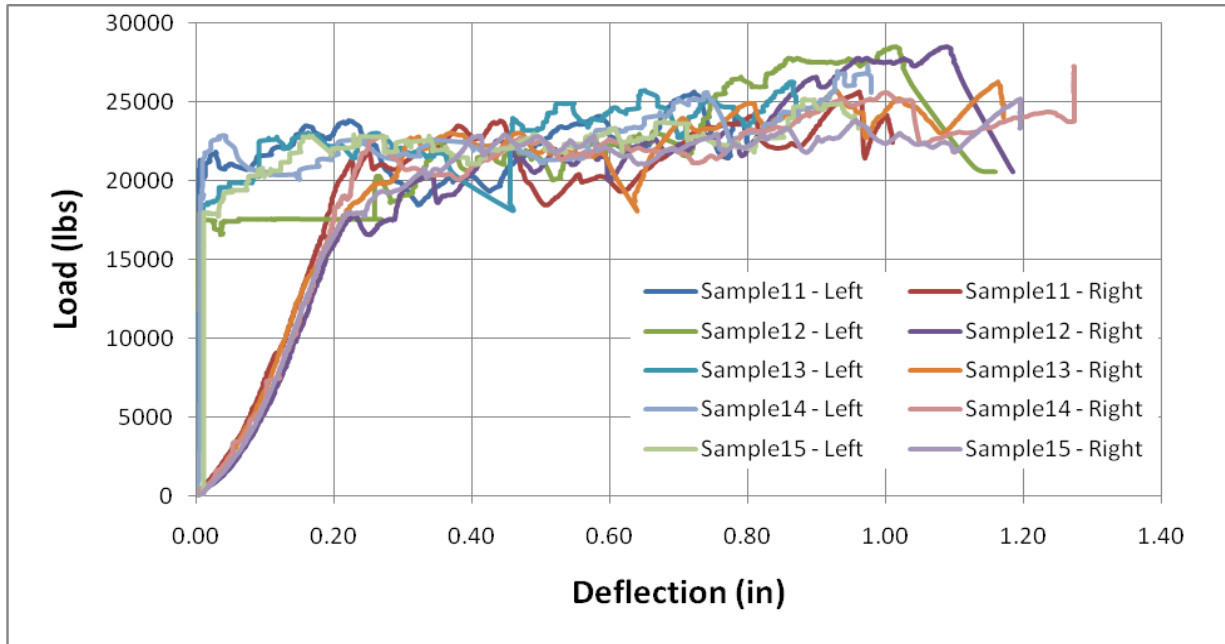

Figure 18: 12 inch Connection Test A Results

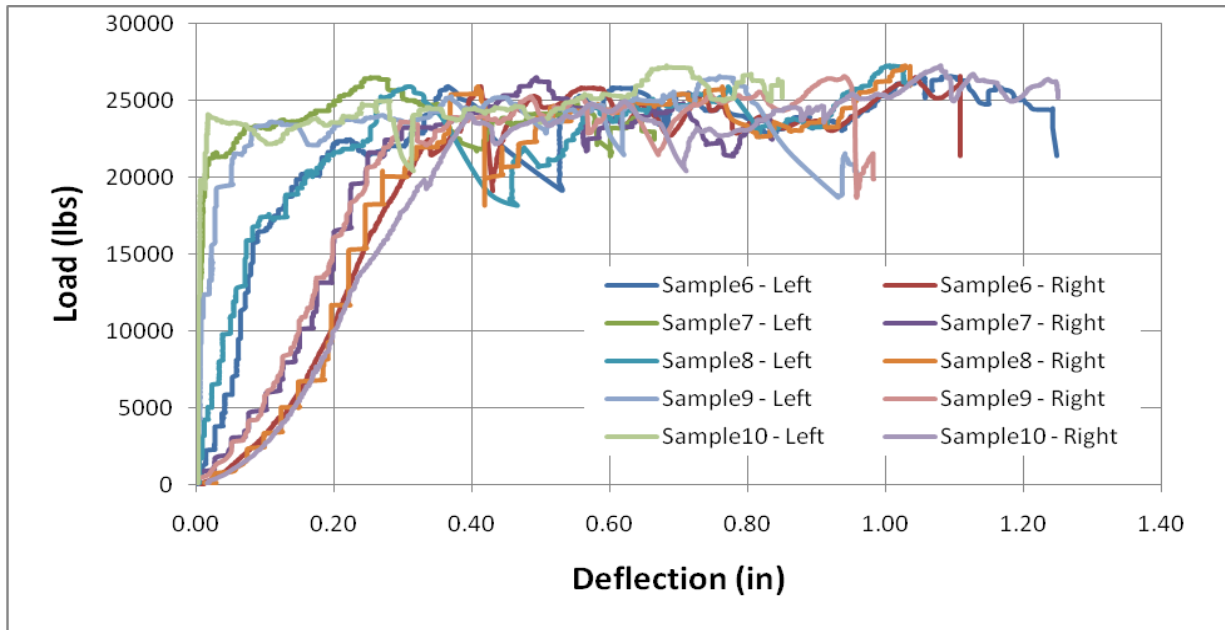

Figure 19: 16 inch Polyurethane Connection Test A Results

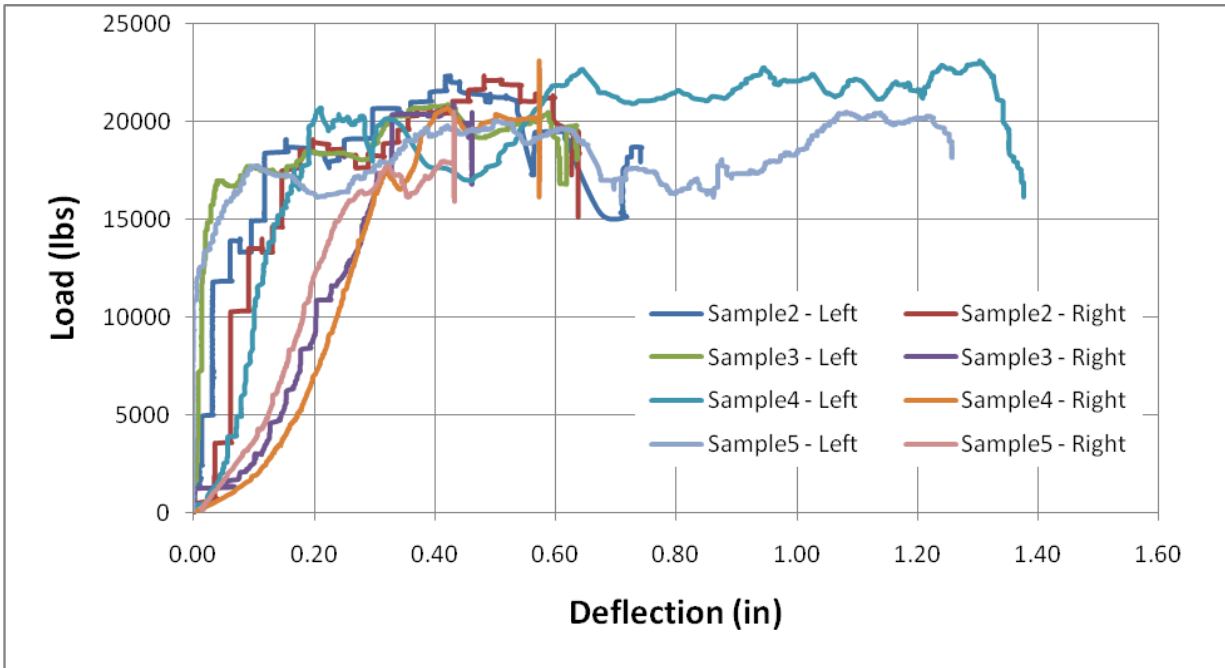

Figure 20: 16 inch Vinyl Ester Connection Test A Results

The load versus deflection curves reveal that a maximum load of approximately 18-20 kips was reached in the 16” vinyl ester samples, while the 16” polyurethane samples reached maximum loads of ~23-25 kips, and the 12” polyurethane samples reached a maximum load of ~22.5 kips.

## 8. Connection Testing B – Washer Test

The failure behavior of the washer testing was found to be local depression around the area of the washer and the washer itself deformed greatly until the load application tools were flat against the test samples (Figure 21). Loading was taken up to about the same point on each sample after initial behavior was witnessed. As seen in Figure 21 the 6 in washer eventually dug into the FRP material and created cracks that propagated along a significant longitudinal distance from the washer (Figure 21). The 6 in washers generally caused less local damage to the sample at equal loads when compared to the 4 in washer. The washer testing results had similar cracking and failure modes on all materials and even all washers; however, the 4 inch washer would create a more local depression and usually caused more local damage (Figure 22). Deflections were obtained using a tape measure at the bottom, measuring the distance from the sample and the nut and are reported in Table 7. The values Table 7 show how much deflection the local depression of the washer caused. These results however vary based on how much load was actually applied which is different with each case so they should be viewed with caution.



*Figure 21: 16-in Sample with 6-in Washer at about 21 kips*



*Figure 22: 12-in Sample with 4-in Washer*

Table 7: Connection Test B Results

Pile Type	Washer Size (in)	Sample (ID #)	Max Load (lbs)	Deflection at Max Load (in)	Average Load (lbs)
16 inch Diameter, 1/2 inch Wall, 72 inch span Polyurethane	4	1	16,402		17,210
		2 (PU6)	17,540	1.563	
		3 (PU6)	17,688	1.750	
	6	1	23,230		22,228
		2 (PU4)	21,226	1.938	
16 inch Diameter, 1/2 inch Wall, 72 inch span Vinylester	4	1	13,161		14,291
		2 (VE2)	15,115	2.188	
		3 (VE4)	14,596	1.500	
	6	1 (VE1)	17,738	1.563	17,837
		2 (VE6)	18,851	1.625	
		3 (VE2)	16,921	1.813	
12 inch Diameter, 1/2 inch Wall, 60 inch span	4	1 (S6)	21,275	1.250	19,569
		2	17,985	1.500	
		3	19,445	1.250	
	6	1 (S1)	24,219	1.563	27,642
		2	24,120	1.750	
		3	34,585	1.563	

## 9. Four Point Bending Fatigue

Each fatigue sample underwent the respective range of loading shown in Table 8. As mentioned earlier the frequency of loading was .075 Hz (cycles/sec).

Table 8: Fatigue Loading Ranges

Material	Average Low Load (kips)	Average Max Load (kips)
12"	4.8	36.41
16" PU	6.94	38.64
16" VE	5.39	36.44

When each of the fatigued samples was tested to failure, both the 16 inch samples failed under the applied load, i.e., under a steel saddle. The 12 inch sample failed in the middle third zone. Deflections were only obtained for one of the samples, because that sample failed violently and damaged the string pot. The results from these samples are shown in Table 9. Also, Table 9 provides the percent change in the results between the average static test data and the fatigue test data.

Table 9: Four Point Bending Fatigue - Failure Results

Samples under Fatigue	Max Load (kip)	Max Deflection (in)	Max Moment (k-in)	Max Stress (ksi)	Max Longitudinal Strain ( $\mu\epsilon$ )	Elastic Modulus (Msi)	Energy (load*defl) (kip-in)
12 inch PU Sample 6	95.85	-	3834	76.89	12941	5.82	-
Percent Difference from Average	5.14	-	5.14	5.14	1.71	-13.56	-
16 inch PU Sample 6	103.72	-	5549	60.65	10372	5.76	-
Percent Difference from Average	2.97	-	3.34	3.34	-8.80	0.16	-
16 inch VE Sample 6	79.00	7.89	4227	46.20	7545	6.05	347.65
Percent Difference from Average	-5.14	-53.46	-6.12	-6.12	-18.13	7.81	-64.62

Tangent SeaTimber (profile-ST-rebar)	Actual Height (in)	Actual Width (in)	Rebar Quantity (ea)	Rebar Size (in)	Flexural Strength (psi)	Flexural Modulus (psi)	Stiffness EI (lb-in <sup>2</sup> )	Moment Capacity (kip-ft)	Weight Range (lb/ft)
8x12-ST-0F00	7 1/2	11 5/8	0	N/A	2,620	154,000	5.73E+07	22	31-38
8x12-ST-4F08	7 1/2	11 5/8	4	1	3,720	219,000	8.16E+07	31	32-39
8x12-ST-4F10	7 1/2	11 5/8	4	1 1/4	4,360	290,000	1.08E+08	36	33-40
8x12-ST-4F11	7 1/2	11 5/8	4	1 3/8	4,670	311,000	1.16E+08	39	33-41
8x12-ST-4F12	7 1/2	11 5/8	4	1 1/2	5,140	343,000	1.28E+07	43	34-41
8x12-ST-4F13	7 1/2	11 5/8	4	1 5/8	5,450	379,000	1.41E+07	45	34-42
8x12-ST-4F14	7 1/2	11 5/8	4	1 3/4	5,800	414,000	1.54E+07	48	35-42
12x8-ST-0F00	11 5/8	7 1/2	0	N/A	2,740	161,000	1.40E+08	35	31-38
12x8-ST-4F08	11 5/8	7 1/2	4	1	3,660	242,000	2.10E+08	46	32-39
12x8-ST-4F10	11 5/8	7 1/2	4	1 1/4	4,360	349,000	3.03E+08	55	33-40
12x8-ST-4F11	11 5/8	7 1/2	4	1 3/8	4,860	389,000	3.38E+08	61	33-41
12x8-ST-4F12	11 5/8	7 1/2	4	1 1/2	5,190	433,000	3.77E+08	65	34-41
12x8-ST-4F13	11 5/8	7 1/2	4	1 5/8	5,680	486,000	4.23E+08	72	34-42
12x8-ST-4F14	11 5/8	7 1/2	4	1 3/4	5,850	532,000	4.53E+08	74	35-42
10x10-ST-0F00	9 7/8	9 7/8	0	N/A	2,700	159,000	1.38E+08	34	33-40
10x10-ST-4F08	9 7/8	9 7/8	4	1	4,610	278,000	2.05E+08	45	34-41
10x10-ST-4F10	9 7/8	9 7/8	4	1 1/4	6,140	351,000	2.59E+08	76	34-42
10x10-ST-4F11	9 7/8	9 7/8	4	1 3/8	6,960	398,000	2.94E+08	86	35-42
10x10-ST-4F12	9 7/8	9 7/8	4	1 1/2	8,280	460,000	3.39E+08	103	35-43
10x10-ST-4F13	9 7/8	9 7/8	4	1 5/8	8,810	503,000	3.71E+08	109	36-44
10x10-ST-4F14	9 7/8	9 7/8	4	1 3/4	9,790	560,000	4.13E+08	121	37-45
12x12-ST-0F00	11 7/8	11 7/8	0	N/A	2,600	155,000	1.14E+08	57	42-51
12x12-ST-4F08	11 7/8	11 7/8	4	1	5,474	290,200	4.68E+08	125	43-52
12x12-ST-4F10	11 7/8	11 7/8	4	1 1/4	6,327	340,900	5.50E+08	144	44-52
12x12-ST-4F11	11 7/8	11 7/8	4	1 3/8	8,413	386,200	6.23E+08	191	45-53
12x12-ST-4F12	11 7/8	11 7/8	4	1 1/2	9,266	448,200	7.23E+08	211	46-53
12x12-ST-4F13	11 7/8	11 7/8	4	1 5/8	10,000*	516,000	8.32E+08	228*	46-54
12x12-ST-8F08	11 7/8	11 7/8	8	1	8,878	483,800	7.80E+08	202	47-55
12x12-ST-8F10	11 7/8	11 7/8	8	1 1/4	10,364	556,000	8.64E+08	226	48-56
12x12-ST-8F11	11 7/8	11 7/8	8	1 3/8	12,440	715,500	1.11E+09	271	48-56
12x12-ST-8F12	11 7/8	11 7/8	8	1 1/2	13,000	788,600	1.22E+09	283	50-59
12x12-ST-8F13	11 7/8	11 7/8	8	1 5/8	14,800	882,000	1.37E+09	325	52-60

Flexural values are ultimate. Resistance factors (LRFD) or safety factors (ASD) must be applied to these values.

Flexural Modulus is a Secant Modulus at 1% strain per ASTM D790. Some values for intermediate configurations have been interpolated.

\* Values are projected based on flexural tests of similar sections

STD025-230613

## Appendix D

When installing the SeaPile<sup>®</sup> and SeaTimber<sup>®</sup>, the user must take the proper precautions used in installing all other types of piling; when cutting, finishing or attaching the SeaPile<sup>®</sup> and SeaTimber<sup>®</sup>, the user should also take all normal precautions, including, but not limited to, the use of hard hats, safety glasses, hearing protection and safety shoes. Operators should be aware of the weight of the SeaPile<sup>®</sup> and SeaTimber<sup>®</sup> prior to lifting. There are no toxic characteristics associated with the SeaPile<sup>®</sup> and SeaTimber<sup>®</sup>. Accordingly, shavings or cut ends may be disposed of wherever plastic is accepted.

LIKE ANY PLASTIC PRODUCT, SEAPILE<sup>®</sup> AND SEATIMBER<sup>®</sup> WILL BURN. THEREFORE, AVOID THE USE OF CUTTING TORCHES OR ANY OTHER OPEN FLAME DEVICES AROUND THE SEAPILE<sup>®</sup> COMPOSITE MARINE PILING.

### DRIVING

The SeaPile<sup>®</sup> Composite Marine Piling exhibits many of the same driving characteristics of a timber pile. Since it is easy to drive, a lightweight hammer with a rated energy of between 8,000 and 15,000 ft-lbs may be used. Care should be taken in selecting the appropriate hammer for the length of pile to be driven. Once the hammer has been selected, a flat driving head should be used to ensure full surface contact with the squared flat top of the entire cross-sectional area of the pile. SeaPile<sup>®</sup> are designed to absorb energy, which is key to their performance as a fender piles, however, as a result, they are less efficient to drive than steel, concrete, or timber piles and will take more blows per foot.

A vibratory pile driver may be used to drive the SeaPile<sup>®</sup> Composite Marine Piling when conditions would permit vibratory driving of traditional timber piling. When planning to use a vibratory pile driver, consider fabricating a steel helmet to minimize damage to the top of the pile, alternatively piles can be supplied in a longer length and trimmed after being installed.

### DRIVING POINTS OR SHOES

Steel driving shoes are not typically required, however they can be purchased and factory installed if difficult driving conditions are anticipated.

### JETTING

SeaPile<sup>®</sup> can be jetted in a manner similar to any traditional timber pile. The post-driving procedures also remain the same.

## CUTTING

SeaPile<sup>®</sup> & SeaTimber<sup>®</sup> are tough and harder to cut than timber. The fiberglass rebars are particularly difficult to cut through without the correct tools. We recommend the following:

### Chainsaw:

- Stihl MS 661 Series, or similar

### Chain Bar:

- 0.404 pitch with a 4040-7 sprocket
- 25" to 34" bar length for SeaPile<sup>®</sup> up to 13" Ø & SeaTimber<sup>®</sup> up to 12"x12"
- 34" bar length for 16" SeaPile<sup>®</sup>

### Chain:

- RAPCO's Impact Resistant Chisel Carbide Tip Chainsaw Chain
  - 0.404" pitch w/ 0.63" gauge
  - RAPCO Part# B3LM-T-RF
  - RAPCO Vancouver, WA: [sales@rapcoindustries.com](mailto:sales@rapcoindustries.com) (800-959-6130)
- Slow, consistent cutting keeping chain temperature low will greatly extend the chain life; excessive heat will stretch the chain beyond adjustment before chisel tips need sharpening
  - Do not use bar/chain oil; oil will mix with the hot plastic and emulsify seizing the bar sprocket and chain within the bar
  - Between cuts chainsaw should be blown with compressed air to remove shavings

Life Expectancy of Carbide Tipped Chains	
10" SeaPile <sup>®</sup>	8 to 10 cuts
13" SeaPile <sup>®</sup>	8 to 10 cuts
16" SeaPile <sup>®</sup>	6 to 10 cuts
8x12, 10x10, 10x12, 12x12 SeaTimber <sup>®</sup>	8 to 10 cuts

## DRILLING / COUNTER BORING

### Drill:

The following drill specification is recommended for all drilling and countersinking:

- Electric: 3/4" chuck or 3 Morse Taper, 250-350 rpm
- Pneumatic: 3/4" chuck, 1.5 to 2 HP, 200-350 rpm
- Minimum Torque: 1,800 in-lb

### Drilling and Counter Boring SeaTimber<sup>®</sup> with No Rebar:

- Standard high-speed steel twist drills are suitable for drilling holes up to 1-1/2" diameter
- For larger holes, a 1" or 1-1/8" Ø pilot hole is recommended, followed by a counter-bore type bit to enlarge the hole to the finished diameter; counter-bore bits can be purchased, fabricated at local machine shop or purchased from Tangent; consult a Tangent rep for custom bits; allow for leadtime



### Drilling and Counter Boring SeaTimber<sup>®</sup> with Rebar:

- Drill a 1" or 1-1/8" Ø pilot hole with a standard high-speed steel twist drill or carbide tipped twist bit if drilling through rebar
- Follow with a carbide insert, counter-bore type bit; consult Tangent rep for custom bits; allow for leadtime
- *CAUTION: Apply light pressure to reduce the risk of the bit snagging on the bar and violently spinning the drill*



### Thermal Expansion and Contraction:

- Holes and counter-bored holes are oversized or slotted to allow for the Coefficient of Thermal Expansion/Contraction of SeaTimber<sup>®</sup> which is larger than traditional materials
- SeaTimber<sup>®</sup> with fiberglass rebar reinforcing = 0.00002 in/in/°F
- SeaTimber<sup>®</sup> with fiberglass filament rebar reinforcing, but no rebar = 0.000033 in/in/°F

## RECOMMENDED REPAIR PROCEDURE

SeaPile<sup>®</sup> & SeaTimber<sup>®</sup> are incredibly durable. There is no need to patch or repair abrasions, cuts or grooves for any other reason than aesthetics.

If repairs are required, it's recommended that a commercially available plastic welder is used with the appropriately colored welding rod to build up the area to be patched. The repaired surface can then be sanded flush.

If a plastic welder is not available, a less refined repair method is detailed below:

### Required Tools:

- Propane torch
- Shavings of plastic matrix, left over from drilling or cutting
- Putty knife
- Sandpaper (80-100 grit) and wooden block
- Orbital or palm type sander

### For Small Patches:

- Pre-heat the hole until the surrounding plastic is soft & tacky, not runny
- Quickly press shavings into the hole and heat until liquified
- Repeat in layers, until the filled void is flush, or standing slightly proud of the surface
- Allow each layer to cool before applying the next
- Sand the patch area, blending in until flush with the outer surface

### For Larger Patches:

- Cut a plug from a cut off to a slightly smaller shape than the void
- Pre-heat the hole until the surrounding plastic is soft & tacky, not runny
- Quickly press shavings into the hole and heat until liquified
- Pre-heat the plug and press into the depression
- Press shavings into the gap around the plug and heat until liquified
- Repeat in layers, until the gap is flush, or standing slightly proud of the surface
- Allow each layer to cool before applying the next
- Sand the patch area, blending in until flush with the outer surface

## LIFTING & HANDLING

The following considerations are recommended to resist damage when lifting SeaPile<sup>®</sup> and SeaTimber<sup>®</sup>:

- Verify the weights and lengths of the material before each lift
- Short length may be handled with care by forklift
- Use a lifting beam to handle longer lengths with pick points at 1/5 of the overall length
- Use a nylon sling or choker to lift without damaging the surface
- All lifting plans and procedures are the responsibility of the customer

## STORAGE

The following considerations are recommended to resist damage when storing:

- Use minimum 4 x 4" dunnage for support
- SeaPile<sup>®</sup>: support at 6' to 10' increments
- SeaTimber<sup>®</sup>: support at 4' increments
- Stack SeaPile<sup>®</sup> and SeaTimber<sup>®</sup> no more than 5' in height
- Chock, band, or tie to secure the stack appropriately
- If stored for an extended period, check the stack periodically for stability
- Store on level surface and bring to project site 24 hours before installation for material to acclimate to ambient temperatures

# Appendix E

Section	TOW EI (ft)	Mudline EI (ft)	Layer 1: Alluvial Sediment					Layer 1: Beaumont Clay					Layer 3: Beaumont Sands	
			D (ft)	c' (psf)	$\phi'$ (deg)	Su - top (psf)	Su - bottom (psf)	D (ft)	c' (psf)	$\phi'$ (deg)	Su - top	Su - bottom	D (ft)	$\phi'$ (deg)
C1	9.0	-10.0	23	42	26	60	336	42	150	28	3012	5956	74	37
C2	9.0	-14.0	27	42	26	200	324	45	150	28	3288	4392	57	37
C3	9.0	-5.0	18	42	26	200	486	38	150	28	2644	4392	57	37
C4	9.0	-9.0	22	42	26	200	488	42	150	28	3012	484	58	37
C5	9.0	-14.5	28	42	26	200	458	45	150	28	3288	4944	63	37

TOW: Top of Wall

D (ft): Distance to top of layer from TOW

Su adjusted to ignore top 4-ft of alluvial sediments



Client IPC and MIMC Job Number 11215702 Sheet \_\_\_\_\_  
 Project San Jacinto River Waste Pits Site Sheets By S.Chilka Date 11-19-2024  
 Subject BMP Design - Barge Impact Checked By \_\_\_\_\_ Date \_\_\_\_\_

### 3. Direct Impact on BMP

The BMP cross-sections were analyzed for barge impact near the top of the wall (exterior sheet pile). The analyses were performed using Plaxis, a finite element software program developed by Bentley Systems, Inc. The program can model complex soil profiles, structural sections and perform soil-structure interaction analysis to achieve a solution with compatible forces and displacements.

The barge impact was evaluated for two cross-sections (C2 and C4) as they represent the two largest exposed heights above the riverbed and are expected to be the most critical sections. A 400-ft long three-dimensional (3D) model was created with the same stratigraphy, material properties and stages as the BMP analysis sections. The linear elastic plates representing the sheet piles are assigned orthotropic parameters to capture the difference in sheet pile stiffness of the vertical and horizontal directions. The results from Cross-Section C4 are applicable for all other locations (except C2).

The barge impact loads were applied as a static uniformly distributed load over a 50 ft x1 ft area near the top of the wall. Due to the instantaneous nature of the impact, the loads are evaluated using the undrained soil parameters and considered an Extreme load condition, with the impact at top of the wall.

Load Case 1 – Load of 20-kip/LF, equivalent to KE at impact velocity of 3.8-ft/s with a ballasted barge.

Load Case 2 – Load of 28-kip/LF, equivalent to KE at impact velocity of 5.3-ft/s with a ballasted barge or 2.2-ft/s with a laden barge.

As Cross-Section C2 is not near the navigational waterway, any impact on the west and northwest portion of the BMP will likely be from barges moored on the north side of the BMP that may come off the mooring in a storm event. Thus, Cross-Section C2 is only evaluated for Case 1 loading scenario. The results from cross-section C4 are applicable to all other locations, except C2.

The barge impact loads caused localized deformation of the exterior wall along with an increase in soil shear strains. However, the strains did not indicate a global failure. In this scenario, there would be localized damage to the BMP on the exterior side due to limiting flexural capacity. The analyses results are summarized in Table 3.1. The section stresses from demand loads are compared to the allowable stresses in the sheet piles for extreme event loading i.e., 0.88 Fy (combined bending moment and axial stress) and 0.58 Fy (shear stress).

Table 3.1 Energy Absorption Capacity of the BMP Structure

BMP Cross-sections + Barge (sheet pile size, barge )	Analysis Demands per Linear Feet of BMP			Sheet Pile Capacity – Extreme Load Condition		Demand to Capacity Ratio	
	Moment (kip.ft)	Shear (kip)	Deflection (ft)	Moment (kip.ft)	Shear (kip)	Moment	Shear
C2 + Barge Ballasted (AZ42-700N)	342.4	64.5	1.4	325	351	1.05	0.18
C4 + Barge Ballasted (AZ 36-700N)	159.6	39.6	0.8	275	276	0.58	0.14
C4 + Barge Laden (AZ 36-700N)	251.2	39.6	1.6	275	276	0.91	0.14

It is noted that Cross-Section C2 would be overstressed by 5% on impact with a ballasted barge at velocity of 3.8-ft/s. Impact forces are directly proportional to the impact velocity squared. The stresses will be lower for impact at 1.8-ft/s (analysis performed at 3.8-ft/s) as the impact force will reduce by 27%. Considering the low probability of impact in the



Client IPC and MIMC Job Number 11215702 Sheet \_\_\_\_\_  
Project San Jacinto River Waste Pits Site Sheets By S.Chilka Date 11-19-2024  
Subject BMP Design - Barge Impact Checked By \_\_\_\_\_ Date \_\_\_\_\_

area of Cross-Section C2, the reduction in impact force at lower velocity and engineering judgement, the 5% overstress for impact with a ballasted barge is acceptable for design.

The Cross-Sections closer to the navigational waterway would be expected to potentially experience barge impact, ballasted or laden, as they are towed. Results from Cross-Section C4 show that the BMP is adequate impact with barges in ballasted and laden condition at velocity 2.2 ft/s even without the FRP barrier wall system.

Detailed calculations and results from the analyses are provided on the next page.



Client IPC and MIMC Job Number 11215702 Sheet \_\_\_\_\_  
 Project San Jacinto River Waste Pits Site Sheets By S.Chilka Date 11-19-2024  
 Subject BMP Design - Barge Impact Checked By \_\_\_\_\_ Date \_\_\_\_\_

**Summary of Impact Force for different impact velocities (V)**

Design Barge 30,000 BBL  
 Width 54 ft  
 Contact Length 50 ft  
 Load Case 1 20 kip/LF = 1000 kip  
 Load Case 2 28 kip/LF = 1400 kip

*Applied over contact area of  
50-ft x 1-ft*

		V (ft/s)	1.0	1.6	2.2	3.8	5.3	
		V (knots)	0.59	0.93	1.30	2.24	3.12	
30,000 BBL Barge, Ballast	KE of Impact		30	74	144	425	829	kip.ft
	Barge Damage Length		0.02	0.04	0.08	0.24	0.47	ft
	Head-On Impact Force		71	176	344	1000	1400	kips
	30-deg Impact Force		54	132	258	750	1050	kips

		V (ft/s)	1.0	1.6	2.2	3.8	5.3	
		V (knots)	0.59	0.93	1.30	2.24	3.12	
30,000 BBL Barge, Laden	KE of Impact		172	425	829	2452	4783	kip.ft
	Barge Damage Length		0.10	0.24	0.47	1.30	2.36	ft
	Head-On Impact Force		409	1000	1400	1492	1609	kips
	30-deg Impact Force		307	750	1050	1119	1207	kips

Notes

- Equivalent to Load Case 1
- Equivalent to Load Case 2
- Maximum Impact Energy for Barrier wall

All contact assumed to be in head-on direction. Angled contact will result in lesser impact force



Client IPC and MIMC Job Number 11215702 Sheet \_\_\_\_\_  
 Project San Jacinto River Waste Pits Site Sheets By S.Chilka Date 11-19-2024  
 Subject BMP Design - Barge Impact Checked By \_\_\_\_\_ Date \_\_\_\_\_

**Summary of Impact Force for different impact velocities (V)**

Design Barge parameters from TXDOT Bridge Pier Design Criteria

Length	300 ft		
Width / Beam	54 ft		
Depth	12 ft	Hull Height	
Water Unit Weight	63 pcf	Brackish water	Applied over contact area of 50-ft x 1-ft
Water Depth	20 ft	Typical water level to mudline	

Two conditions of the barge - empty (ballast) and fully loaded (laden) are considered to determine the impact force for a head-on collision with the BMP

Ballast Draft	1.8 ft	Unloaded / Empty Barge	
UKC Ratio, Ballast	10.22	Underkeel clearance to water depth ratio	
Ballast Displacement	1820 kips	Lightship condition	
Alternate Units	829 tonne	813 LT	910 tons
Laden Draft	10.3 ft	Loaded Barge	
UKC Ratio, Laden	0.94	Underkeel clearance to water depth ratio	
Laden Displacement	10500 kips	Total Weight of the Barge + Cargo	
Alternate Units	4783 tonne	4688 LT	5250 tons
Deadweight, DWT	9400 kips	Cargo Capacity	
Alternate Units	4282 tonne	4196 LT	4700 tons

**Maximum Impact Force for Ballasted Barge - AASHTO Section 3.14**

Impact Velocity, V 5.3 ft/s 1.60 m/s

Kinetic Energy,  $KE = \frac{C_H W V^2}{29.2}$  kip.ft (Eq. 3.14.7-1)

Where, W = Total or Laden Displacement (tonne) Note: 1 tonne = 0.98 LT  
 V = Impact Velocity  
 C<sub>H</sub> = Hydrodynamic Mass Coefficient

C<sub>H</sub>, Ballast 1.05 UKC Ratio > 0.5

<b>KE, Ballast</b>	823 kip.ft	1117 kN.m	<< <b>Impact Energy</b>
--------------------	------------	-----------	-------------------------

The total impact force is directly proportional to the horizontal damage length for a barge

Damage Length  $a_B = 10.2 \left( \sqrt{1 + \frac{KE}{5,672}} - 1 \right)$  (Eq. 3.14.12-1)

a<sub>B</sub>, Ballast 0.46 ft The 10.2 factor is for 35ft wide barge. It should be modified by (10.2 / (Barge Width / 35 ft)) for others.

<b>Impact Force, Ballast</b>	1400 kip	(Eq. 3.14.11-2)	= 4112 a <sub>B</sub> , if a <sub>B</sub> < 0.34
			= 1349 + 110 a <sub>B</sub> , if a <sub>B</sub> ≥ 0.34



Client IPC and MIMC Job Number 11215702 Sheet \_\_\_\_\_  
 Project San Jacinto River Waste Pits Site Sheets By S.Chilka Date 11-19-2024  
 Subject BMP Design - Barge Impact Checked By \_\_\_\_\_ Date \_\_\_\_\_

**Maximum Impact Force for Laden Barge - AASHTO Section 3.14**

Impact Velocity, V 2.2 ft/s 0.67 m/s

Kinetic Energy,  $KE = \frac{C_H W V^2}{29.2}$  kip.ft (Eq. 3.14.7-1)

Where, W = Total or Laden Displacement (tonne) Note: 1 tonne = 0.98 LT  
 V = Impact Velocity  
 C<sub>H</sub> = Hydrodynamic Mass Coefficient

C<sub>H</sub>, Laden 1.05 UKC Ratio > 0.5

<b>KE, Laden</b>	823 kip.ft	1117 kN.m	<< Impact Energy
------------------	------------	-----------	------------------

The total impact force is directly proportional to the horizontal damage length for a barge

Damage Length  $a_b = 10.2 \left( \sqrt{1 + \frac{KE}{5,672}} - 1 \right)$  (Eq. 3.14.12-1)

a<sub>B</sub>, Laden 0.46 ft The 10.2 factor is for 35ft wide barge. It should be modified by (10.2 / (Barge Width / 35 ft)) for others.

<b>Impact Force, Laden</b>	<b>1400 kip</b>	(Eq. 3.14.11-2)	= 4112 a <sub>B</sub> , if a <sub>B</sub> < 0.34
			= 1349 + 110 a <sub>B</sub> , if a <sub>B</sub> ≥ 0.34



Client IPC and MIMC Job Number 11215702 Sheet \_\_\_\_\_  
 Project San Jacinto River Waste Pits Site Sheets By S.Chilka Date 05-21-2025  
 Subject BMP Design - Barge Impact Checked By \_\_\_\_\_ Date \_\_\_\_\_

Elevations (ft)	NAVD88
Top of Wall (Exterior)	+10
Top of Wall (Interior)	+9
Top of Water Outside	+10

Steel Sheet Pile, Fy =  ksi

Loading Condition	Allowable Stress Factor	
	Moment & Axial Load	Shear
Usual, U	0.50	0.33
Unusual, UNU	0.67	0.44
Extreme, EXT	0.88	0.58
Elastic Yield, YLD	1.00	1.00

<< Damage Condition

Sacrificial thickness (tc) - for accounting corrosion  in << maximum demand is in submerged / embedded zone  
 Corroded flange thickness (trf) - two exposed faces  in and not compared with the end  
 Corroded web thickness (trw) - two exposed faces  in of design life capacity (corroded  
 Corroded section modulus Sr  in<sup>3</sup>/ft section)  
 Corroded section area Avr  in<sup>2</sup>/ft

**Corroded Section Capacities**

Sheet Pile Section	S (in <sup>3</sup> /ft)	tf(in)	trf(in)	Sr (in <sup>3</sup> /ft)	Moment (kip.ft / LF)			
					U	UNU	EXT	YLD
AZ 26-700	48.40	0.48	0.48	48.40	121	161	212	242
AZ 40-700N	74.30	0.67	0.67	74.30	186	247	325	372
AZ 36-700N	66.80	0.59	0.59	66.80	167	222	292	334
AZ 42-700N	78.20	0.71	0.71	78.20	196	260	342	391

Sheet Pile Section	Av (in <sup>2</sup> /ft)	tw(in)	trw(in)	Avr (in <sup>2</sup> /ft)	Shear (kip / LF)			
					U	UNU	EXT	YLD
AZ 26-700	8.69	0.48	0.48	8.69	172	229	301	522
AZ 40-700N	10.25	0.52	0.52	10.25	203	270	355	615
AZ 36-700N	8.67	0.44	0.44	8.67	172	228	300	520
AZ 42-700N	10.83	0.55	0.55	10.83	214	285	375	650

**Sheet Pile Design Summary - Barge Impact Study**

Using Ultimate factor to assess damage by barge impact

Analysis Sections	Design Load (kip/ft)	Total Applied Force (kip)	Analysis Demands per LF			DCR - Moment		DCR - Shear	
			Moment (kip-ft)	Shear (kip)	Deflection (ft)	EXT	YLD	EXT	YLD
<b>C2, AZ 42-700N</b>	20	1000	405.3	32.1	1.5	1.18	1.04	0.09	0.05
<b>C4, AZ 36-700N</b>	20	1000	270.4	26.6	1.1	0.93	0.81	0.09	0.05
	28	1400	376.2	36.7	2.1	1.29	1.13	0.12	0.07

Total Force = Design Load x Contact Area (50 ft x 1 ft)

DCR > 1.0 indicates risk of overstress and damage that will require detailed structural condition assessment, extensive repairs and replacement of sheet pile wall after such impact. Results show localized damage and do not indicate collapse.



Client IPC and MIMC Job Number 11215702 Sheet \_\_\_\_\_  
Project San Jacinto River Waste Pits Site Sheets By S.Chilka Date 05-21-2025  
Subject BMP Design - Barge Impact Checked By \_\_\_\_\_ Date \_\_\_\_\_

### Analysis Output Results - Section C2 - 20kip/ft design load

#### Deflection Output

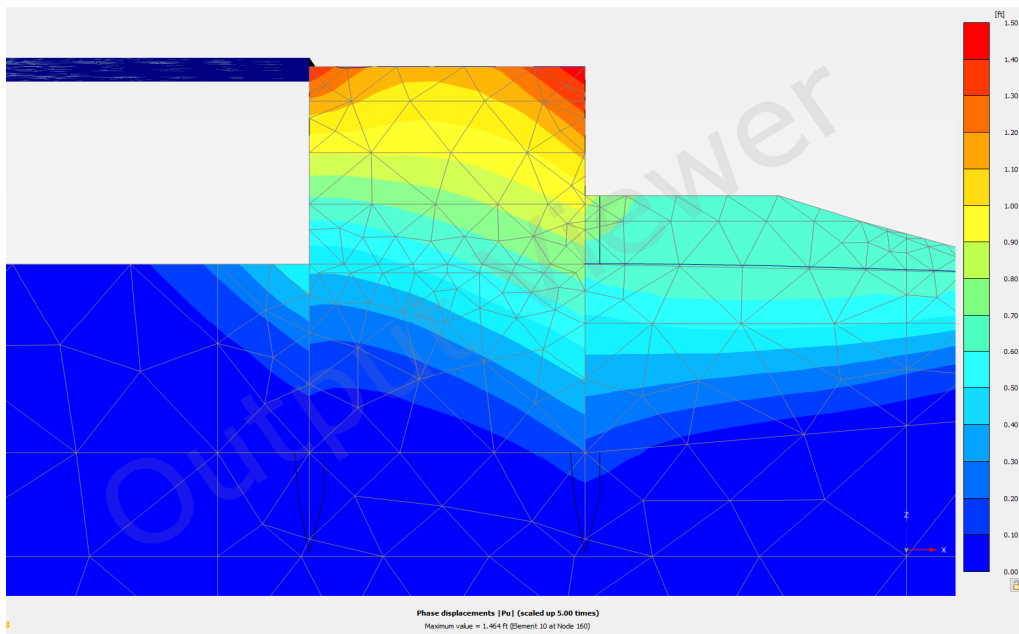
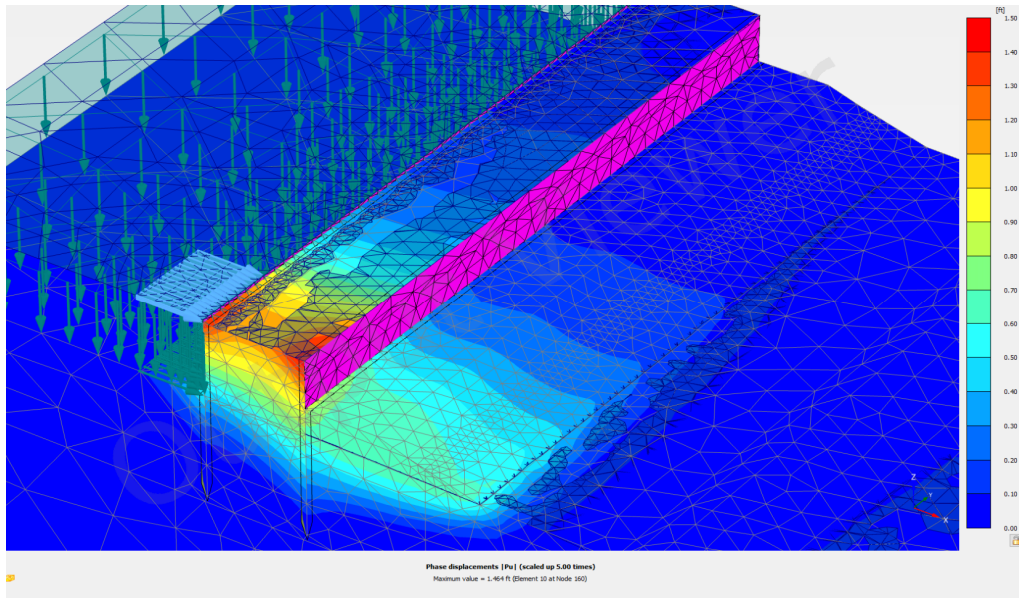



Client IPC and MIMC Job Number 11215702 Sheet \_\_\_\_\_  
Project San Jacinto River Waste Pits Site Sheets By S.Chilka Date 05-21-2025  
Subject BMP Design - Barge Impact Checked By \_\_\_\_\_ Date \_\_\_\_\_

### Bending Moment Output

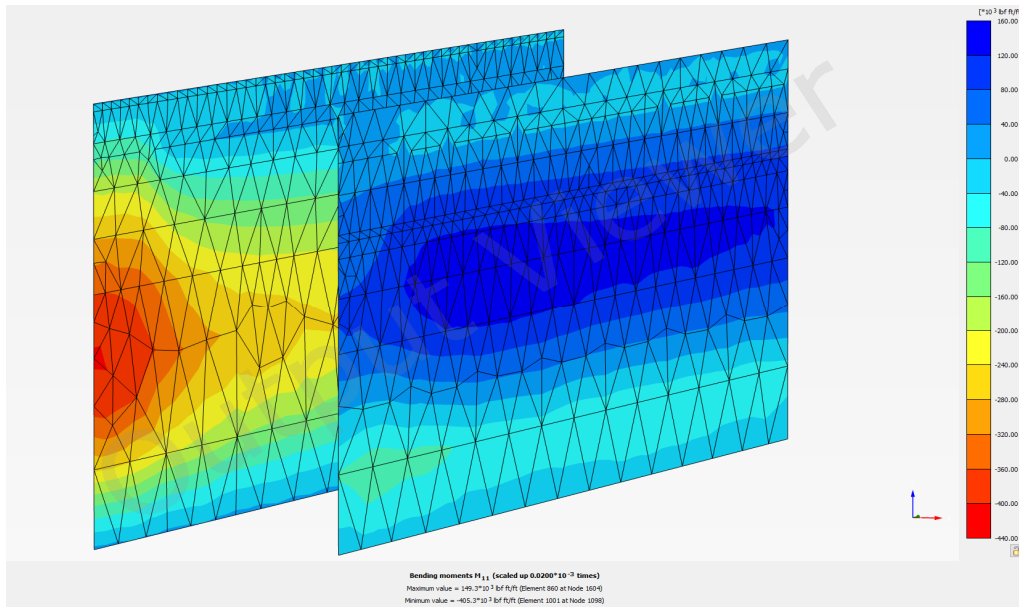

### Shear Force Output

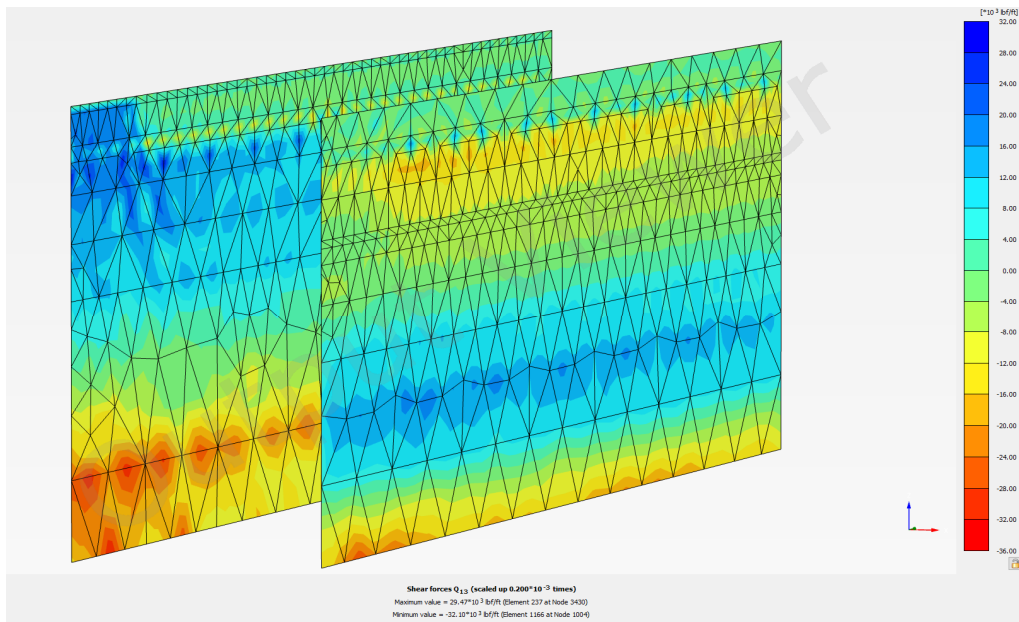



Client IPC and MIMC Job Number 11215702 Sheet \_\_\_\_\_  
Project San Jacinto River Waste Pits Site Sheets By S.Chilka Date 05-21-2025  
Subject BMP Design - Barge Impact Checked By \_\_\_\_\_ Date \_\_\_\_\_

### Analysis Output Results - Section C2 - 28kip/ft design load

#### Deflection Output

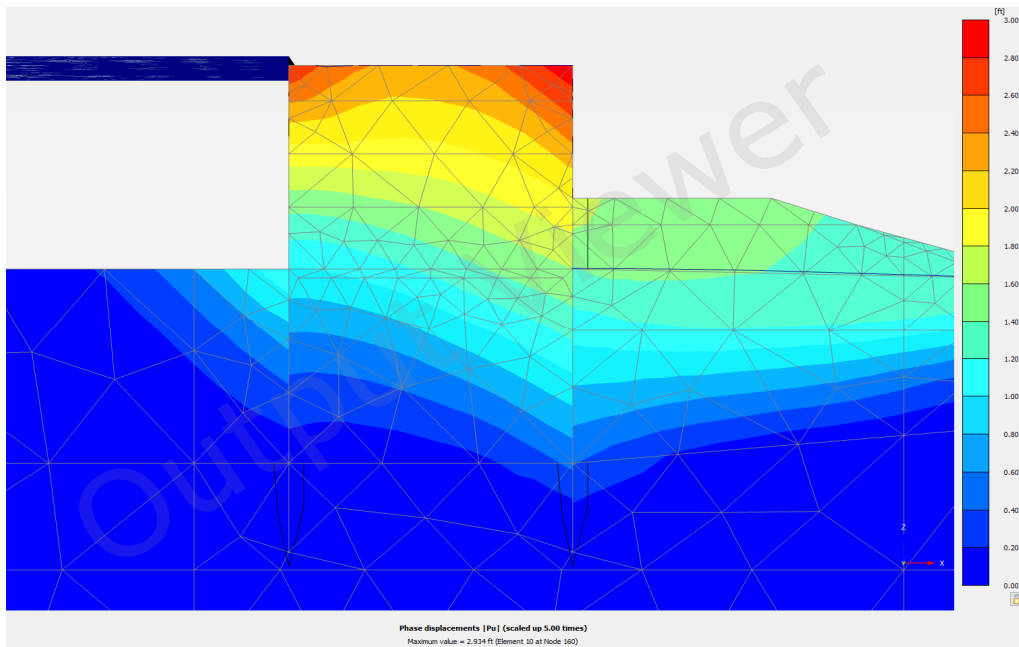
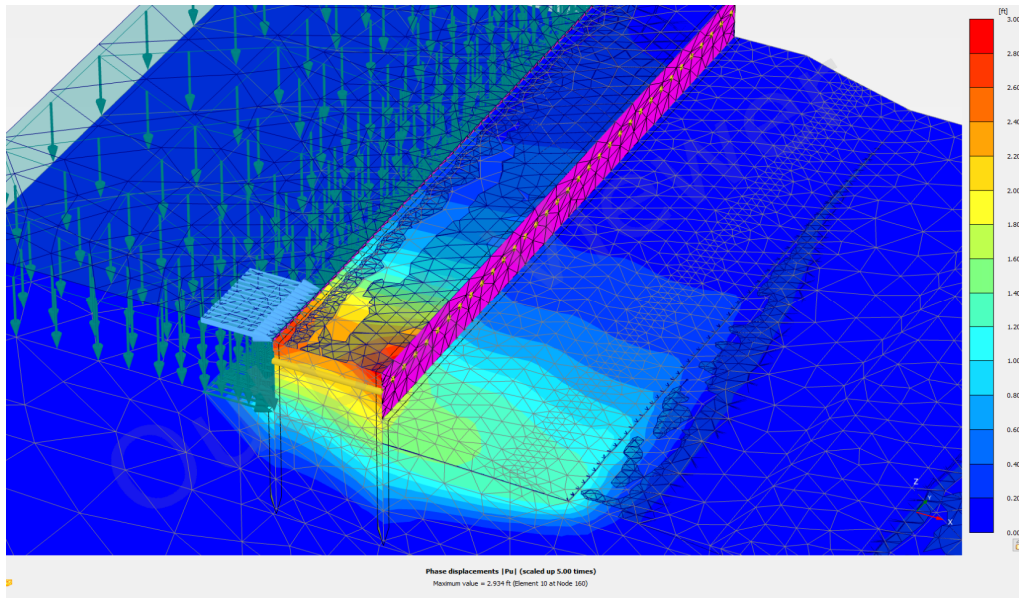



Client IPC and MIMC Job Number 11215702 Sheet \_\_\_\_\_  
Project San Jacinto River Waste Pits Site Sheets By S.Chilka Date 05-21-2025  
Subject BMP Design - Barge Impact Checked By \_\_\_\_\_ Date \_\_\_\_\_

### Bending Moment Output

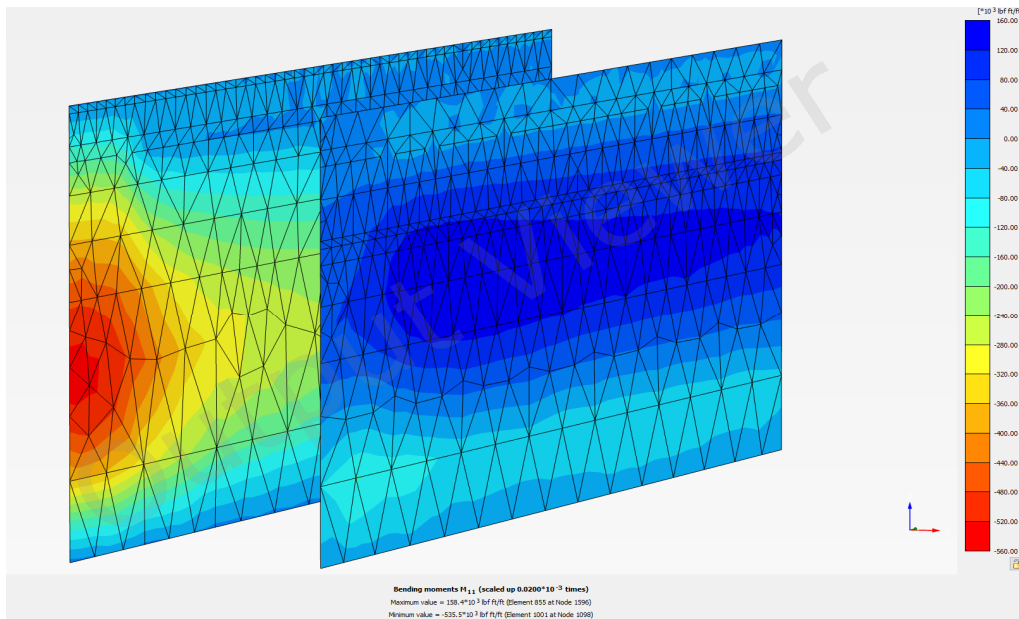

### Shear Force Output

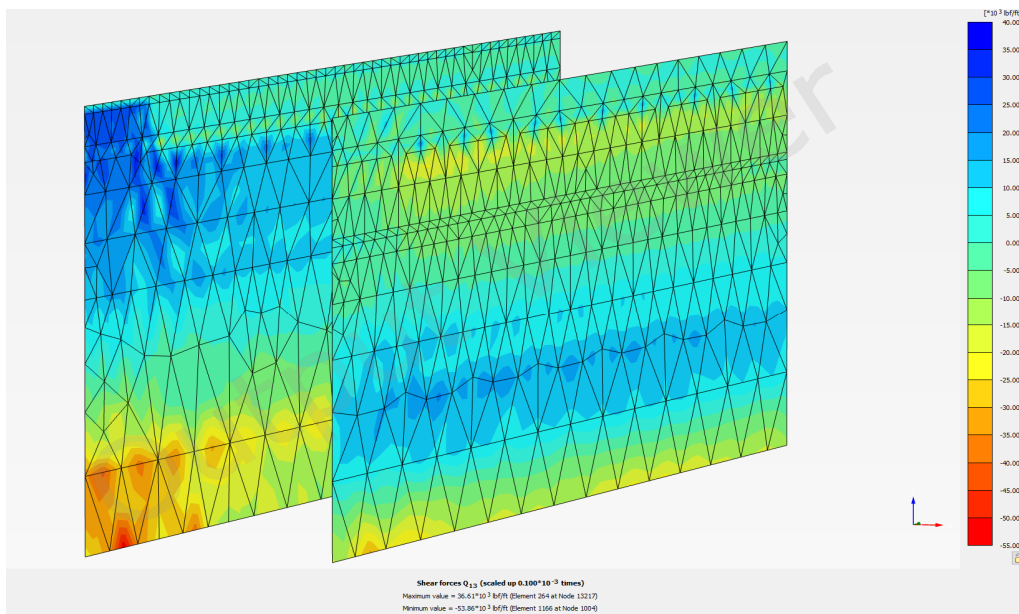



Client IPC and MIMC Job Number 11215702 Sheet \_\_\_\_\_  
Project San Jacinto River Waste Pits Site Sheets By S.Chilka Date 11-19-2024  
Subject BMP Design - Barge Impact Checked By \_\_\_\_\_ Date \_\_\_\_\_

#### **4. References**

1. Hydrodynamic Modelling Report, San Jacinto River Waste Pits - Northern Impoundment by GHD, June 2024.
2. Velocity Buoy Data Processing, San Jacinto River Waste Pits - Northern Impoundment by GHD, November 2024
3. American Association of State Highway Transportation Officials, AASHTO LRFD Bridge Design Specifications, Section 3.14.



Client IPC and MIMC Job Number 11215702 Sheet \_\_\_\_\_  
Project San Jacinto River Waste Pits Site Sheets By S.Chilka Date 07-11-2024  
Subject BMP Design - Pile Driveability & Vibration Checked By \_\_\_\_\_ Date \_\_\_\_\_

APPENDIX I - BMP STRUCTURAL DESIGN REPORT  
**ATTACHMENT 3.7**  
**WEAP OUTPUT**

Ardaman and Associates, Inc.  
San Jacinto\_APE 100 Vib Hammer

Apr 24 2024  
GRLWEAP Version 2010

Gain/Loss 1 at Shaft and Toe 0.400 / 1.000

Depth ft	Ultimate Capacity kips	Friction kips	End Bearing kips	Penetration Time sec/ft	Comp. Stress ksi	Tension Stress ksi	Frequency Hz	Power kw
6.0	10.9	3.4	7.6	0.0	0.000	0.000	30.0	0.0
10.0	16.9	9.3	7.6	0.0	0.000	0.000	30.0	0.0
12.0	21.0	13.4	7.6	0.0	0.000	0.000	30.0	0.0
15.0	28.5	20.9	7.6	1.2	2.353	-1.865	30.0	0.5
20.0	44.8	37.2	7.6	1.8	2.173	-1.992	30.0	0.8
25.0	65.8	58.2	7.6	2.3	2.246	-1.940	30.0	1.1
30.0	91.4	83.8	7.6	2.5	3.291	-2.206	30.0	1.6
35.0	121.6	114.1	7.6	2.4	4.648	-3.457	30.0	2.5
40.0	158.0	147.4	10.6	3.2	6.110	-4.647	30.0	3.4
45.0	191.7	181.2	10.6	3.9	7.322	-5.733	30.0	4.1
50.0	225.8	215.2	10.6	4.6	8.448	-6.911	30.0	5.2
54.0	253.3	242.7	10.6	5.2	9.271	-7.810	30.0	6.1
55.0	260.2	249.6	10.6	5.4	9.469	-8.023	30.0	6.4

Gain/Loss 1 at Shaft and Toe 0.400 / 1.000

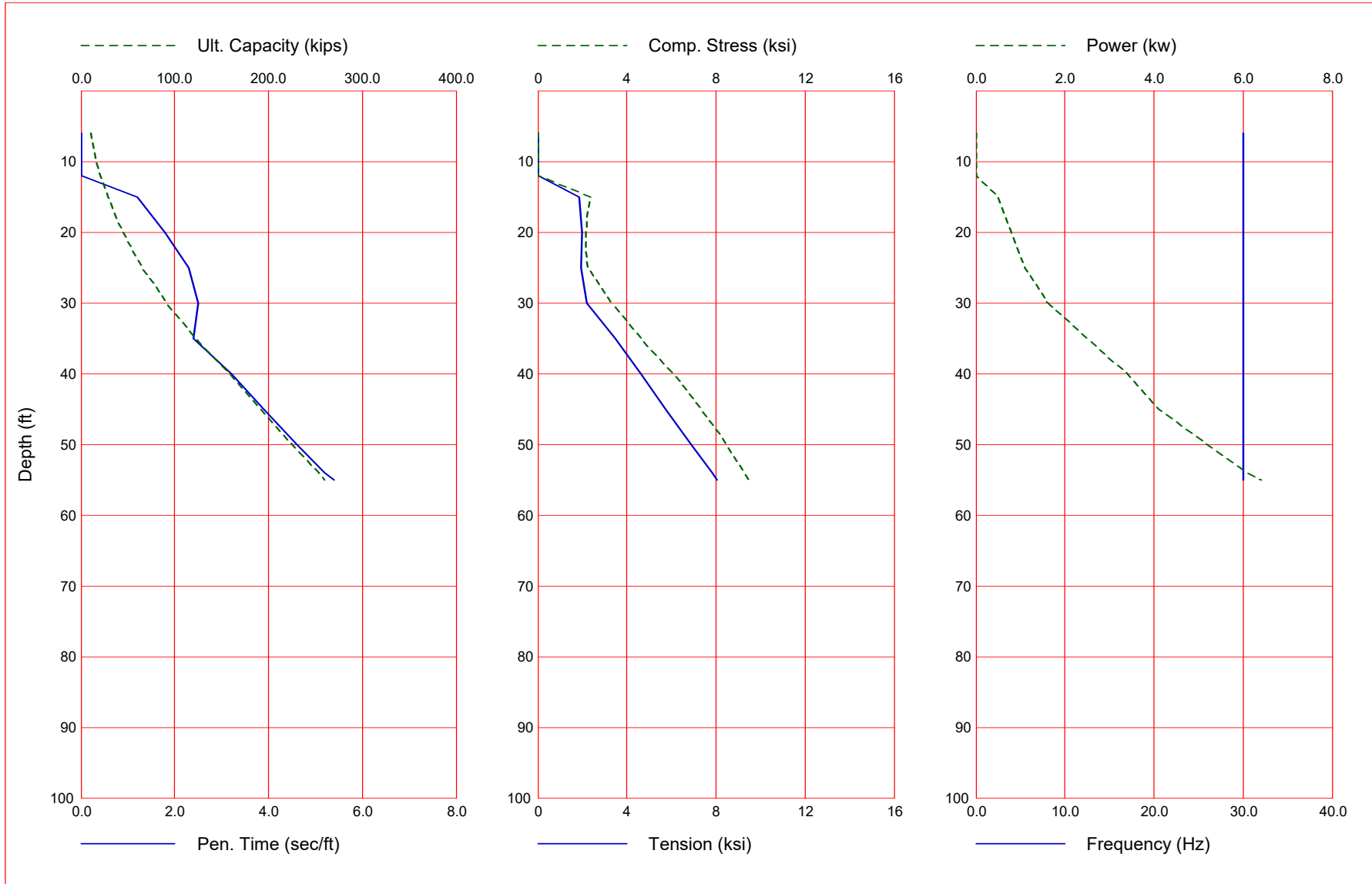

Ardaman and Associates, Inc.  
 San Jacinto\_PACO 36-3000

Apr 30 2024  
 GRLWEAP Version 2010

Gain/Loss 1 at Shaft and Toe 0.500 / 1.000

Depth ft	Ultimate Capacity kips	Friction kips	End Bearing kips	Blow Count blows/ft	Comp. Stress ksi	Tension Stress ksi	Stroke ft	ENTHRU kips-ft
6.0	11.1	3.5	7.6	0.0	0.000	0.000	3.00	0.0
10.0	17.3	9.8	7.6	6.3	15.867	-12.083	3.00	6.3
15.0	29.5	22.0	7.6	12.1	15.867	-11.171	3.00	6.3
20.0	46.6	39.0	7.6	20.7	15.867	-10.162	3.00	6.3
25.0	68.5	61.0	7.6	32.0	15.867	-9.164	3.00	6.3
30.0	95.4	87.8	7.6	43.8	15.867	-8.126	3.00	6.3
35.0	127.1	119.5	7.6	63.6	15.867	-6.978	3.00	6.3
40.0	166.1	155.5	10.6	86.9	15.867	-5.671	3.00	6.3
45.0	203.4	192.8	10.6	105.1	15.867	-4.721	3.00	6.2
50.0	241.6	231.0	10.6	128.5	15.867	-3.987	3.00	6.2
52.0	257.1	246.5	10.6	139.6	15.867	-3.955	3.00	6.2
55.0	280.8	270.2	10.6	159.1	15.867	-3.994	3.00	6.2

Total Number of Blows: 2886 (starting at penetration 6.0 ft)

Driving Time (min): 96 72 57 48 41 36 32 28 26 24  
 @Blow Rate (b/min): 30 40 50 60 70 80 90 100 110 120

Driving Time for continuously running hammer; any wait times not included

Ardaman and Associates, Inc.  
 San Jacinto\_PACO 36-5000

Apr 30 2024  
 GRLWEAP Version 2010

Gain/Loss 1 at Shaft and Toe 0.500 / 1.000

Depth ft	Ultimate Capacity kips	Friction kips	End Bearing kips	Blow Count blows/ft	Comp. Stress ksi	Tension Stress ksi	Stroke ft	ENTHRU kips-ft
6.0	11.1	3.5	7.6	0.0	0.000	0.000	3.00	0.0
10.0	17.3	9.8	7.6	4.2	17.243	-12.692	3.00	11.1
15.0	29.5	22.0	7.6	6.4	17.243	-11.595	3.00	11.1
20.0	46.6	39.0	7.6	10.8	17.243	-10.325	3.00	11.1
25.0	68.5	61.0	7.6	16.1	17.243	-8.973	3.00	11.1
30.0	95.4	87.8	7.6	22.9	17.243	-7.476	3.00	11.1
35.0	127.1	119.5	7.6	30.3	17.243	-5.842	3.00	11.1
40.0	166.1	155.5	10.6	42.2	17.243	-4.136	3.00	11.0
45.0	203.4	192.8	10.6	54.6	17.243	-3.235	3.00	10.9
50.0	241.6	231.0	10.6	64.8	17.243	-2.484	3.00	10.8
52.0	257.1	246.5	10.6	69.4	17.243	-2.298	3.00	10.8
55.0	280.8	270.2	10.6	77.2	17.243	-2.196	3.00	10.8

Total Number of Blows: 1450 (starting at penetration 6.0 ft)

Driving Time (min): 48 36 29 24 20 18 16 14 13 12  
 @Blow Rate (b/min): 30 40 50 60 70 80 90 100 110 120

Driving Time for continuously running hammer; any wait times not included



**PILE DRIVING  
CONTRACTORS  
ASSOCIATION**

**STEEL SHEET PILE GUIDES**

# **BASIC PRINCIPLES OF HAMMERS FOR SHEET PILE INSTALLATION**

# Impact Hammer Technology

## Hammer selection

Hammer selection is the most important aspect of pile installation. In many cases only one hammer type may be applicable for the pile-soil combination, whereas others may require several hammers to cope with the varying conditions.

One major advantage of an impact hammer is that the blow count record during pile installation is a direct measure of the pile resistance. The **vertical advance of a pile under a given hammer blow is used as a measure of the pile's bearing capacity**. The hammer's interaction with the pile-soil system is both modeled before driving (wave equation analysis) and monitored during pile installation (Pile Driving Analyzer).

Vibratory hammers are widely used to drive and extract sheet piles, but they are less commonly used to drive bearing piles. Where bearing capacity is required, the use of impact hammers is the predominant installation technique employed.

Impact hammers are also essential to drive sheet piles when soil density increases. SPT 'N' values approaching 40 generally indicate the limit of vibratory hammer efficiency. Here, impact hammers come into their own by being able to shear through dense soils to reach the design penetration depth.

Impact hammers are usually supported by a leader rig or can be freely suspended by a crane.

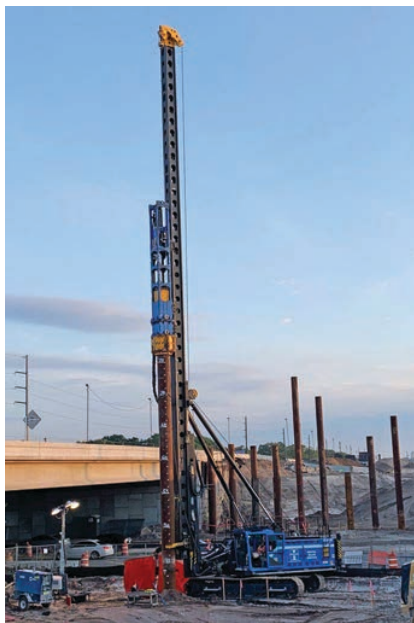

Leader rig



Crane suspended hammer

## What is an impact hammer?

An impact hammer is a specialty hammer used to drive sheet piles into the ground.

Impact pile driving hammers consist of a ram and an apparatus that allows the ram to move quickly upwards and then fall onto the driving system and pile. The ram must have a mass and impact velocity that is sufficiently large to move the pile.

A properly functioning hammer strikes the pile in quick succession. It transfers a large portion of the kinetic energy of the ram into the pile. The stroke of a pile driving hammer is usually between three and ten feet (900 to 3,000 mm).

Cover background: strizh/123RF

## How does an impact hammer work?

The most common forms of impact hammers in use today are hydraulic drop hammers and diesel hammers. While they operate differently, they are both used to drive sheet piles, pipe piles, H-piles and specialty wide flange piles by allowing a ram weight to fall onto the top of the pile.

### Hydraulic impact hammers

Hydraulic fluid is applied to the piston to move the ram. A hydraulic power pack provides the pressurized fluid to operate the hammer. Hydraulic impact hammers can be single acting, double acting, differential acting or other variations. Most but not all hydraulic hammers employ the use of an electric valve operated with a variable timer. The timer allows for flexible control of the output energy. Others use a purely hydraulic system to control the valve and thus the cycling of the ram.

Most hydraulic hammer manufacturers claim high efficiencies for their hammers. Although there are many improvements in hydraulic hammers that enable a more efficient drop, the main reason for the higher efficiencies is that they have some kind of downward assist to equalize the hydraulic flow during the hammer cycle.



Hydraulic hammer

## Diesel hammers

An **open-end diesel hammer** consists of a long slender piston (the ram), which moves inside a cylinder. The cylinder is open at its upper end, thus allowing the ram to partially emerge from the cylinder. The ram falls under gravity to the pile cap. Upon impact, the ram pushes the pile cap and pile head rapidly downward. The impact block separates from the ram within a very short time and the pressure of the combusting air-fuel mixture will cause further separation as the ram is forced upward.

A **closed-end diesel hammer** cylinder is closed at its upper end, thus causing the ram to compress the air trapped between ram and cylinder top. When the ram falls, it is subject to both gravity and the pressure in the *bounce chamber*, hence called **double acting**.

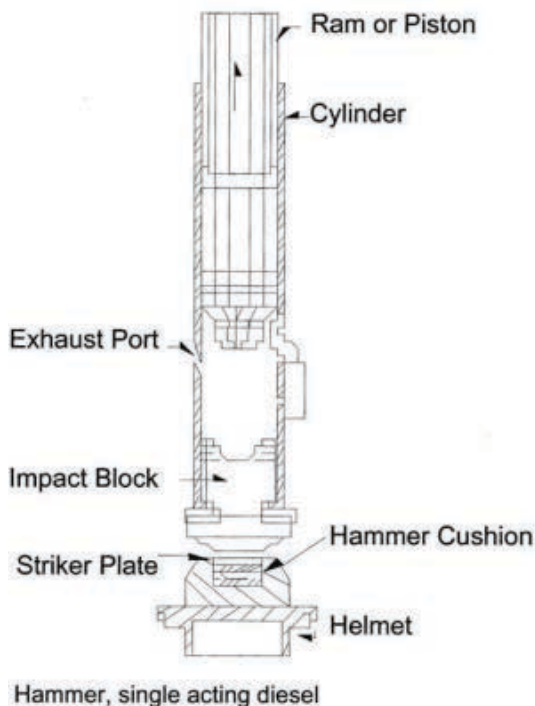

Diesel hammer

## Pile cap

To ensure that as little energy as possible is lost in the transfer to the pile, the driving energy is transferred to the pile via a driving cap or spreader plate. The driving cap also ensures the hammer blows act centrally on the pile. The pile cap is matched to the shape of the sheet pile being driven.

A central connection between the hammer and the pile and exact guidance of the hammer on the leader are key prerequisites for accurate pile driving. If the hammer is not concentric with the pile, then the eccentricity may lead to pile head damage and/or pile lean.



Typical driving cap for Z-sheet piles

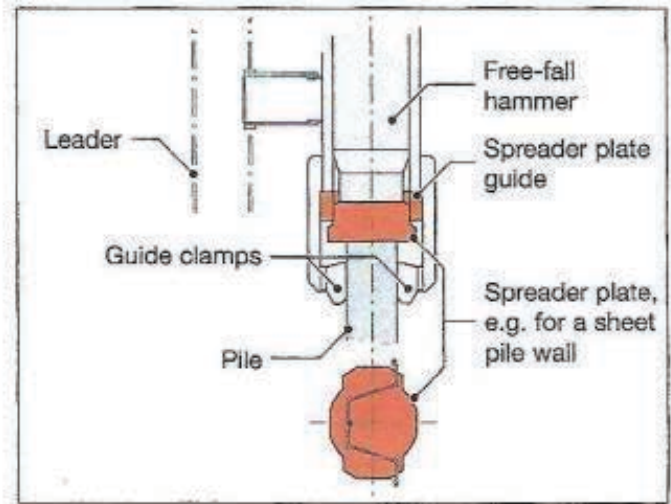
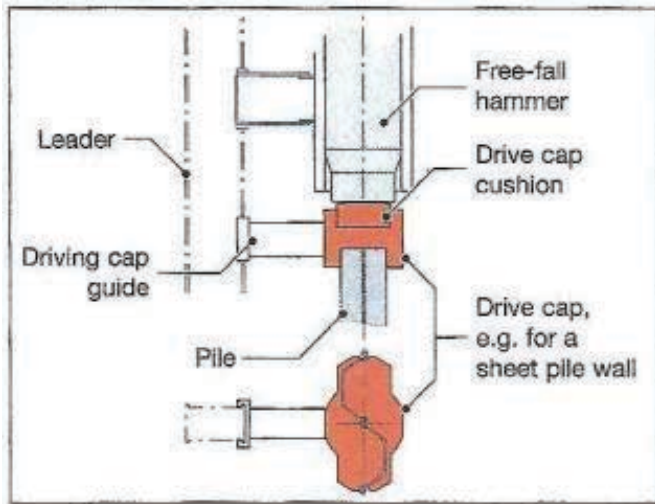

Typical driving cap and spreader plate detail

The form of driving cap must be matched to the sheet pile that is to be driven. It is attached to the underside of the hammer by a loose attachment and is guided by the leader where used.

### Sizing the impact hammer

Impact hammers are of the size needed to develop the energy required to drive the piles at a blow count that **does not exceed 10 blows per inch** at the required ultimate pile capacity. The intent is to select the size of hammer at normal operating condition to be sufficient. Occasionally, it may be required to drive to a higher blow count to penetrate an unforeseen thin, dense layer or minor obstruction. Jetting or drilling may be a preferred means to penetrate a particularly dense layer. Overdriving often will damage the pile and/or hammer.

In its simplest form, the impact energy delivered per drop hammer blow is simply the weight of the ram times the fall distance to the pile cap.

A 3,000 lb. ram falling 10 feet (with no bounce on the pile cap) at impact would deliver 30,000 ft-lbs of energy. Twice the height of the bounce is deducted from the total drop height to determine the net drop and calculation of delivered energy.

A general rule of thumb for hydraulic drop hammers is to match the ram mass to the mass of the sheet pile being driven. Therefore, if a 50-foot-long pair of Z-26 sheet piles weighs 3.5 tons, then it would be reasonable to use a three-ton ram mass with a standard drop. As the drop height can be controlled by the operator, then the installation could begin with a small drop to get the pile penetration underway. Drop height would increase as needed to ensure a minimum penetration rate.

A more scientific and accurate approach is to use **wave equation analysis**. The industry has largely adopted wave equation analysis and it has become a well-used tool for pile driving evaluation. Contractors will often use the wave equation to optimize equipment selection and hammer makers often make equipment recommendations based on the wave equation analysis.

Wave equation analysis is a numerical method of analysis for the behavior of driven foundation piles. It predicts the pile capacity versus blow count relationship (bearing graph) and pile driving stress – for example, when a soft or hard layer causes excessive stresses or unacceptable blow counts. While popular, it is best carried out by an engineer familiar with the software to ensure appropriate results.

The screenshot shows the GRLWEAP software interface for a project titled "GARLAND TRUSS BRIDGE HP12X53 (5 PILES)". The interface is divided into several sections:

- Hammer Information:** A table for selecting a hammer from a list.
 

ID	Name	Type	Ram Wt	Energy/Power
93	HITACHI HNC125	ECH	27.5573	108.493
101	KOBE K 13	DED	2.8700	25.428
103	KOBE K22Est	DED	4.8500	45.347
- Hammer parameters:** Input fields for Efficiency (0.8), Pressure (1400.0 psi), and Stroke (8.86 ft).
- Ultimate Capacities (up to 10):** A table for defining capacities in kips.
 

Capacity	Capacity
1	500.0
2	100.0
3	200.0
4	300.0
5	400.0
6	500.0
7	600.0
8	700.0
9	800.0
10	900.0
- Soil Parameters:** Input fields for Quake (0.1 in), Shaft (0.04 in), and Toe (0.04 in).
- Damping:** Input fields for Shaft (0.05 s/ft) and Toe (0.15 s/ft).
- Shall Resistance:** Input fields for Percentage (3%) and Dist. Shape Num (0.0).
- Residual Stress Analysis:** Set to "No".
- Graphical View:** A vertical cross-section showing a pile being driven into the ground. The pile is labeled "KOBE K 13" and has a ram mass of "3.50 in" and "1.69 kips". The ground surface is at 0 feet, and the pile extends down to 20.0 feet. The soil is represented by a yellow gradient.

# Vibratory Hammer Technology

## What is a vibratory hammer?

A vibratory hammer is a specialty hammer used to drive sheet piles in or out of the ground. Impact hammers use a large weight to strike the pile. Vibratory hammers are relatively quiet and have many advantages, such as fast installation. They can also extract sheet piles, can be used underwater, are lightweight, protect the environment (especially animal life) and can be used in close proximity to residential areas without noise complaints. They are also relatively small and are easy to transport.

## How does a vibratory hammer work?

Unlike traditional pile driving equipment that uses a large weight or ram to strike a pile, vibratory hammers use spinning counterweights to create vibration in the pile. The vibration sends the soil particles into suspension enabling the pile to slip through the soil.

The ability of a hammer to drive sheet piles is dependent on the sheet pile size, mass and the soil conditions present.

The vibratory hammer's ability to drive a pile is a combination of driving force, frequency, amplitude and free-hanging weight. The driving force of a hammer is determined by its **eccentric moment** and steady-state frequency.

- **Eccentric Moment** – The eccentric moment is calculated by the eccentric weight (M) and the distance from the center of gravity to the rotation axis (r).

$$M = (m \cdot r)$$

- **Centrifugal Force (F)**

$$F = 0,011 \cdot N^2 \cdot 10^{-3} \cdot M$$

- **Amplitude (A)**

$$\frac{2 \cdot M}{M_d} \times 1000 \quad M_d = \text{Dynamic Weight}$$

The size of the eccentric moment affects the driving force, attainable amplitude, operating frequency and power requirements for the hammer.

- Eccentric moment equals the distance from the center line of gravity to the center line of rotation, times the total number of eccentrics in the hammer.
- Amplitude is the vertical movement of the total vibrating system, and the direct result of the applied force generated by the rotating eccentrics.

Amplitude = 2 x eccentric moment ÷ vibrating mass (hammer and pile weight)

**Worked example:**

A hammer weighing 8,750 lbs and with an eccentric moment of 2,600 in/lbs is driving a PZ 27 sheet pile 40 ft long. What will the amplitude be?

$$\text{PZ-27} = 40.5 \text{ lbs/ft} \times 40' = 1,620\text{lbs} \times 2 \text{ (driven in pairs)} = 3,240 \text{ lbs (total weight of pair)}$$

$$\frac{2,600 \text{ in/lbs (eccentric moment)}}{8,750 \text{ (weight)} + 3,240 \text{ (pile weight)} \times 2}$$

$$\frac{(2,600)}{(11,990) \times 2} = (.216) \times 2 = .432 \text{ amplitude, or } \mathbf{\text{amplitude} = 7/16''}$$

For effective driving, the hammer must have amplitude of equal to or greater than a quarter of an inch.

Generally speaking, the higher the amplitude, the more effective the hammer will be at driving piles in soils considered marginal to vibratory driving. Higher amplitudes may also increase risk of damage to adjacent structures.

- The eccentrics of a vibratory hammer are attached to a shaft, and are mounted in pairs opposite one another, on a horizontal plane inside the gearbox. The pinion shaft(s) are connected to a hydraulic motor/motors mounted to the outside of the gear box. As the eccentrics rotate in opposite directions, their horizontal forces cancel one another out, leaving only vertical vibration.

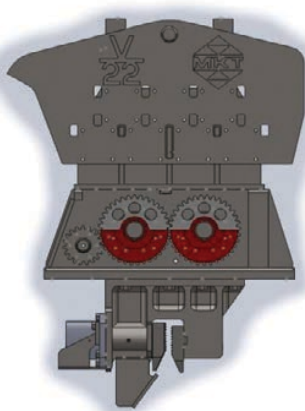

Position #1

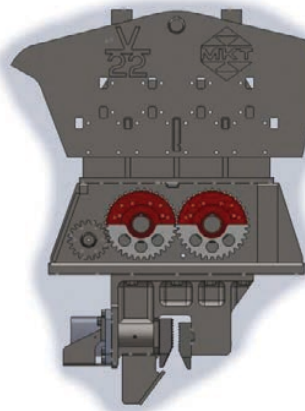

Position #3

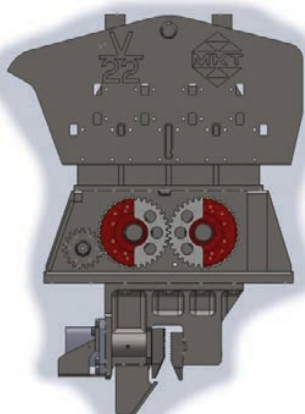

Position #2

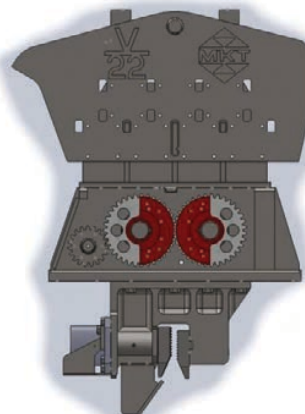

Position #4

## What is the difference between an electric and a hydraulic vibratory hammer?

In the market today, there are two main types of vibratory hammers – electric and hydraulic. Electric hammers and hydraulic hammers have many differences but have similar traits.

Both electric and hydraulic hammers use a “power unit” that powers the hammer. Both have clamps allowing the hammer to connect to the pile. Both use wires or hoses to connect the hammer to the power unit.

Electric vibratory hammers use a large electric motor on top of the hammer to spin the counterweights. To power the electric motor, a large power unit with a diesel engine will turn a generator, giving enough power to the motors.

Hydraulic hammers use hydraulic motors to spin the counterweights. To power the hydraulic motors, a large power unit with a diesel engine turns hydraulic pumps, which flow oil out to the motors and back.

Hydraulic hammers are much more powerful than electric hammers and are half the weight. The other main advantage is that they can spin at a much faster speed. The higher the vibration speed, the less vibration will travel through the soil to surrounding buildings.

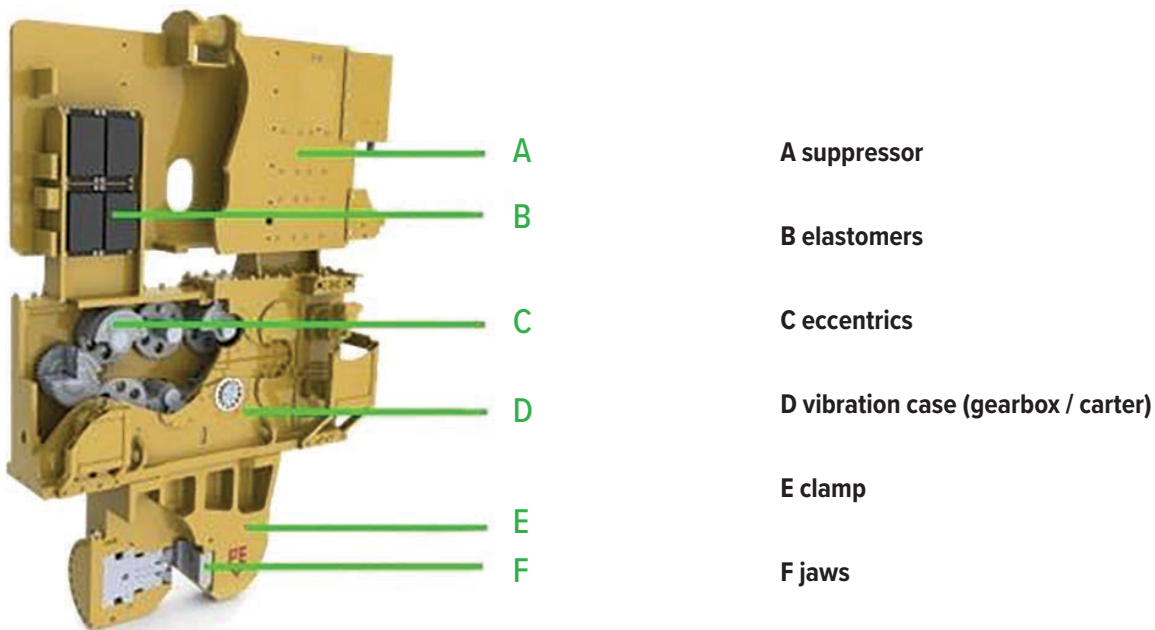

The design of a vibratory hammer

## Vibration generation

The vibration case has two pairs of eccentric weights that rotate in a vertical plane to create vibration. This generates centrifugal force. When two unbalanced eccentrics maintaining the same moment are rotated in opposite directions, vertical (up and down) vibration of constant cycle is produced.

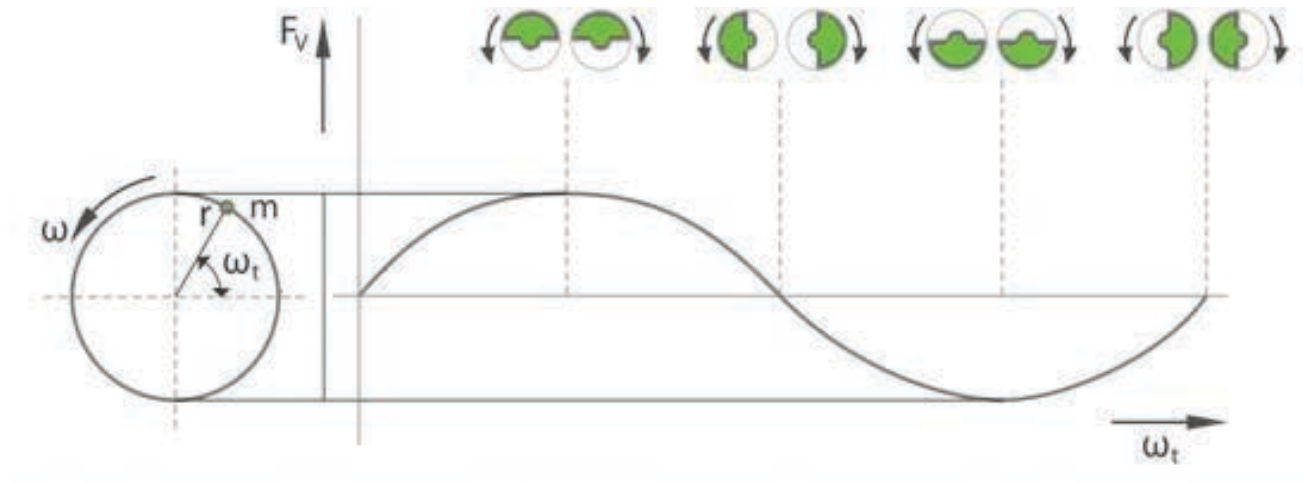

$F_v$  vertical force       $r$  rotations per minute  
 $w$  angular frequency       $w_t$  angular frequency  $\pi$ -radian  
 $m$  mass

The weights are driven by hydraulic engines. The eccentrics are gear-connected to maintain proper synchronization. The eccentric shafts are mounted in heavy-duty roller bearings. The maximum capacity of the engines is hydraulically limited.

## Suppressor

The extraction head contains rubber elements (elastomers) to isolate vibrations from the vibration case to the crane or pile driving rig.

## Clamp

The hammer has a hydraulic clamp containing two gripping jaws, one fixed and one moveable, that grip onto the sheet pile. A cylinder, integrated in the clamp body, operates the moveable jaw and has a pilot operating check valve that keeps the cylinder under pressure in case of hose damage. The clamp is operated hydraulically.

## The hydraulic system

The classic pile driving setup includes a power pack and a vibratory hammer. The heart of any vibratory hammer is the exciter block, containing pairs of counter-rotating eccentrics.

The power pack is driven by a diesel engine and supplies the oil flow to the vibrator via hydraulic pumps to drive the piling into the soil.

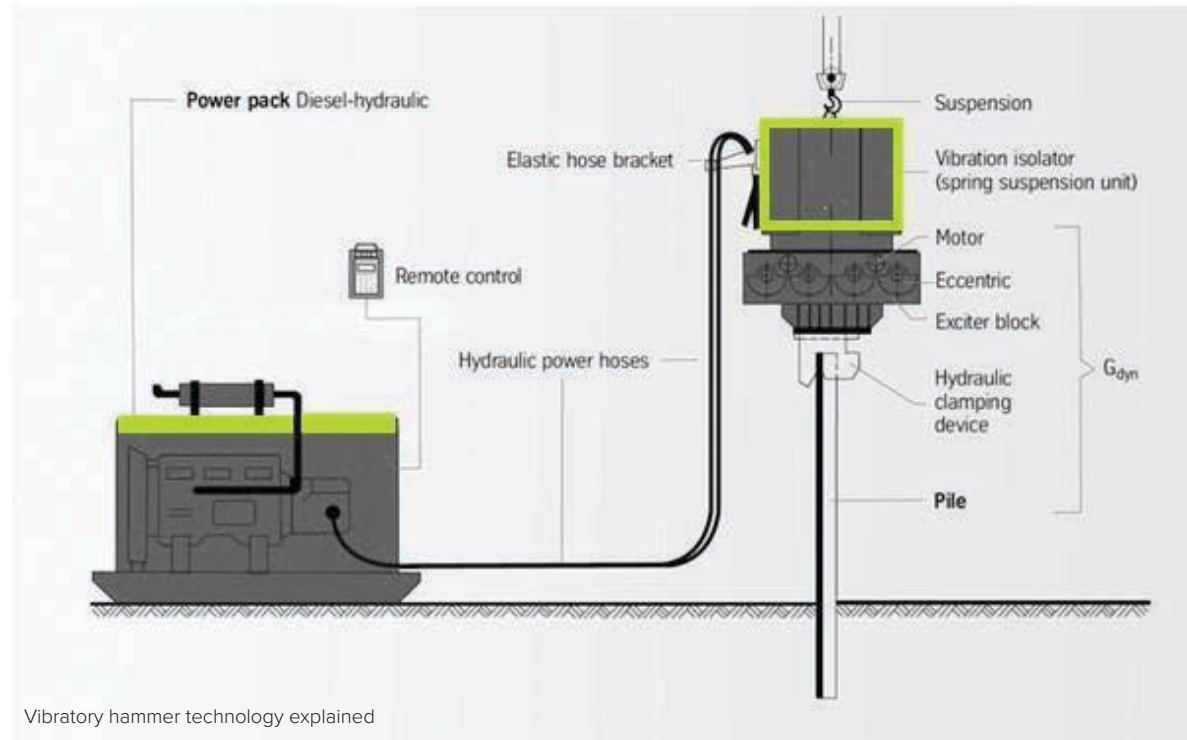

## Variable moment technology

A vibratory **hammer** with a **variable** eccentric **moment** can be started and stopped without vibration. For this, the eccentrics are placed in a zero position with an adjustment motor (with opposite centers of gravity, resulting in a cancellation of the eccentric force).

After the vibratory hammer has reached full speed, the eccentric moment is set causing the vibratory hammer to vibrate. It is possible to set the eccentric moment at a value from 0 to 100%. The operational rpm of these vibratory hammers is higher than that of low frequency vibratory hammers. Where a low frequency vibratory hammer will rotate with approximately 1,500 revolutions per minute, a high frequency (HF) vibratory hammer will rotate with approximately 2,300 revolutions per minute.

Due to this high rotational speed, the vibratory hammer operates further away from the soil's resonance frequency – and due to the smaller amplitude, these vibratory hammers are less harmful to the surroundings. Tests have demonstrated that the vibration level of a HF hammer measured at a distance of 2m from the sheet pile equals the level of vibrations produced by a low frequency hammer at a distance of 16m.

Also, when vibrating a steel sheet pile into the ground, the adjustment motor can be adjusted to influence the eccentric moment and therefore the amplitude. This will allow optimum adjustment of the vibratory hammer.

Conventional vibratory hammers have a constant eccentric moment. When passing the critical frequency area during start-up and stop, the constant amplitude will cause disturbing negative vibrations in the boom of the crane and in the soil to a considerable perimeter distance.

*Content and photos in this section are courtesy of American Piledriving Equipment, ThyssenKrupp/Müller and PVE-Holland.*

# Press-in Machine Technology

## What is press-in piling?

Press-in piling is a unique method of pile driving that uses hydraulic force without the use of vibration or percussion to install piles. This method consists of a few different variations carried out by different types of equipment. These variations include installation with gravity-based machines, tall leader-masts with press-in attachments and reaction-based press-in piling machines.

Advantages of the press-in piling method include:

- Minimal noise impacts
- Imperceptible vibration (non-vibratory)

Of the aforementioned types of press-in variations, reaction-based press-in piling machines are by far the most prevalent. Additional advantages and capabilities of press-in piling with reaction-based press-in piling machines include:

- Installation into hard soil conditions (with attachments)
- Installation within very limited horizontal and vertical clearances
- Safe installation with controlled accuracy
- Installation within a small footprint
- Installation with controlled, measured and monitored static loads

## How do press-in piling machines work?

Press-in piling machines are designed to install steel sheet and pipe piles without using vibration or percussion and do so by deriving its source of potential energy from the reaction of already installed piles that are essentially integrated with the ground (White et al., 2002). Press-in machines obtain this reaction by hydraulically clamping onto the tops of the installed piles, thereby using their reaction to create a press-in force in order to press in subsequent piles.

Figure 1 illustrates that with this mechanism, even a compact press-in machine can create a press-in force that is by far greater than its weight. Since these machines hold the sheet and pipe piles near or at ground level to press them in, hardly any press-in energy is lost that would otherwise generate unwanted noise, vibration or the deformation of piles with conventional pile driving equipment.

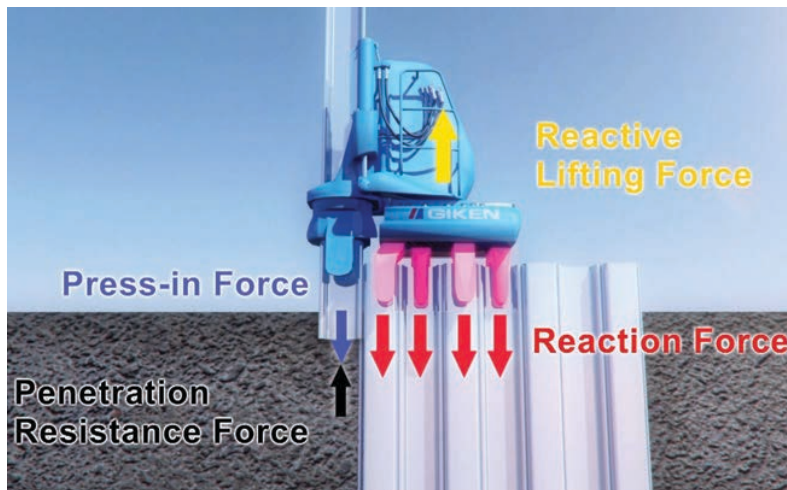

Figure 1

The safety of piling equipment handling is also enhanced since the point of contact between press-in machines and piles near or at ground level and is not suspended at a high elevation as it would be for the many types of conventional piling equipment.

## Advantages and limitations of press-in piling machines

Press-in machines are ideally and commonly utilized on projects with challenges such as with noise and vibration sensitivity or restrictions. In addition to their non-vibratory and minimal noise attributes, press-in piling machines do not require a large footprint since these machines are designed to operate and advance along the top of installed piles. Therefore, press-in machines are also utilized for projects with space or access limitations. Since challenges differ from project to project, it is imperative that the conditions and parameters of challenging project sites are reviewed before a feasibility study is carried out in order to determine which press-in machine type is applicable. In addition to press-in machines being used to install piles for shoring, retaining walls, flood walls, seawalls, etc., press-in machines are also utilized to extract piles in many cases where impact or vibratory hammers alone may not be able to do so.

Although press-in piling machines are useful for the installation of steel sheet and pipe piles on challenging projects, press-in machines are not able to install or extract H-piles, concrete piles or certain sized cold-formed Z-shaped sheet piles. Although few and far between, there are certain sized hot-rolled Z-shaped sheet piles and pipe piles that are not compatible with press-in machines as well.

## Basic press-in piling components

Figure 2 shows the basic press-in components of the press-in machine, power pack, pile laser and radio controller. The radio controller allows the machine operator to precisely control the machinery efficiently at a safe position/location. Since press-in machines use highly accurate infrared pile lasers placed 50 to 100 feet away from the location where the press-in machine is operating, conventional lead and driving templates are not required for press-in machines to install sheet and pipe piles.

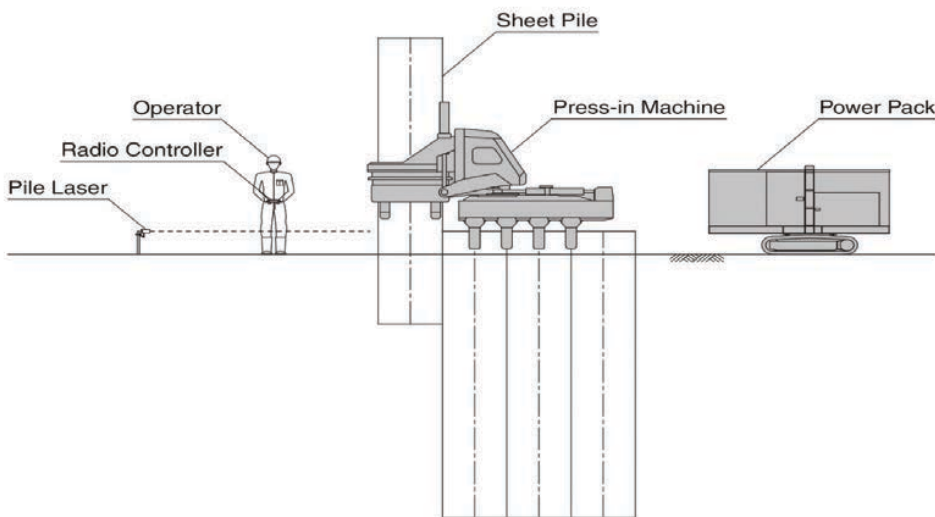

Figure 2

## Non-vibratory pile installation with low noise

With the imperceptible vibration and minimal noise characteristics of press-in machines, the next two graphs will illustrate how low their levels typically are in comparison with conventional pile driving equipment. Figure 3 shows a comparison of ground vibration measurements among press-in piling, vibratory hammer piling and diesel hammer piling at *Site 2* (*Site 1* was press-in piling only) where Peak Particle Velocity output for the press-in machine was between 0.3 and 0.7 mm/s (0.01 – 0.03 in/sec) from 7.15 meters (23.5 feet) away from the pile alignment (White et al, 2002).

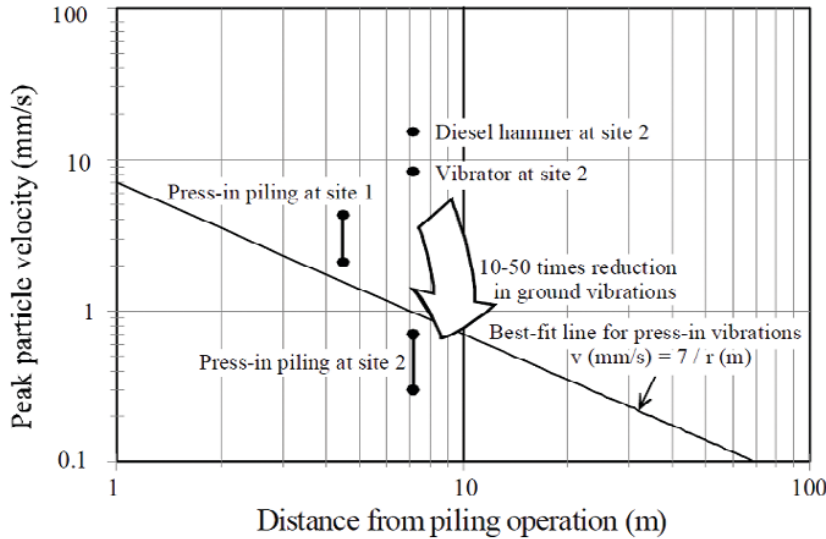

Figure 3

Figure 4 below displays noise data for a double acting diesel/air hammer, hydraulic drop hammer, enclosed drop hammer and a press-in machine (referred to as *Silent Piler*) within the graph. The graph shows that the *Silent Piler* does not exceed the rural noise limit of 70 dB at a distance of two meters (White et al, 2002).

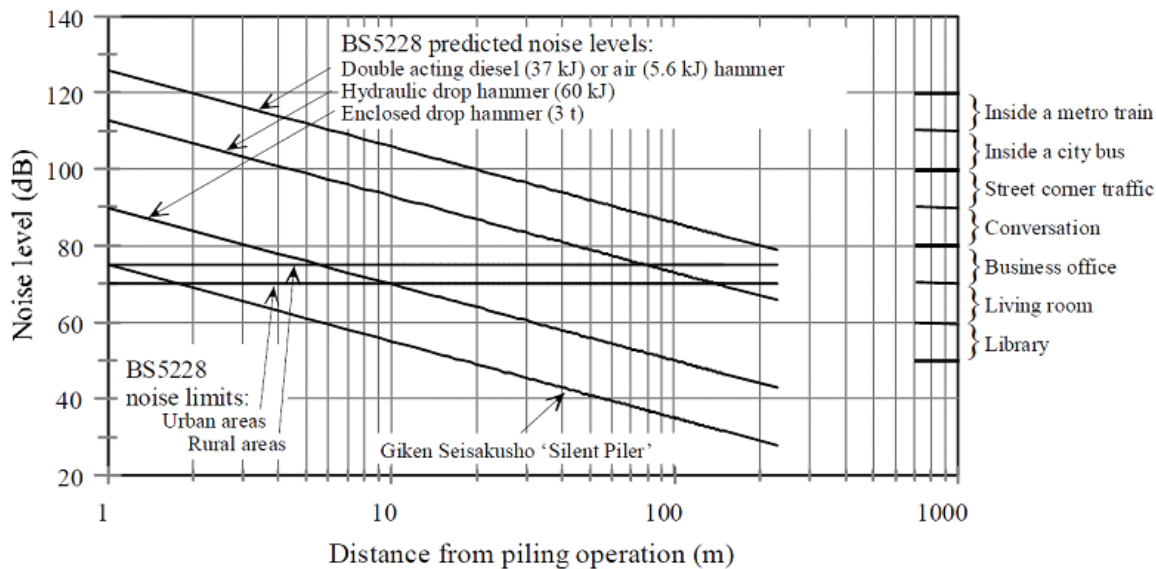

Figure 4

## Capability to install piles in various soil conditions

Press-in piling machines utilize certain techniques to assist press-in machines in installing sheet and pipe piles into various types of ground conditions that range in various densities and depths. These techniques include:

- Standard press-in
- Press-in with water jetting
- Press-in with simultaneous augering
- Press-in with rotary cutting

**Standard press-in piling** is the press-in installation of piles without the need of the aforementioned water jetting, simultaneous augering or rotary cutting systems. In terms of steel sheet piles, standard press-in installation is typically performed where SPT N value is  $N < 25$ . For pipe pile installation, standard press-in installation is typically performed where SPT N value is  $N < 15$ .

**Water jetting systems** are designed to temporarily break up soil composition by loosening granular soils or lubricating cohesive soils with high pressured water to allow smoother pile installation into the ground. The image on the left in Figure 5 shows a press-in machine utilizing its water jetting system, which can be seen within the red circle as the reel affixed to the top of the machine. A water pump providing high pressured water would be nearby. The image on the right in Figure 5 illustrates what the operation would look like underground.

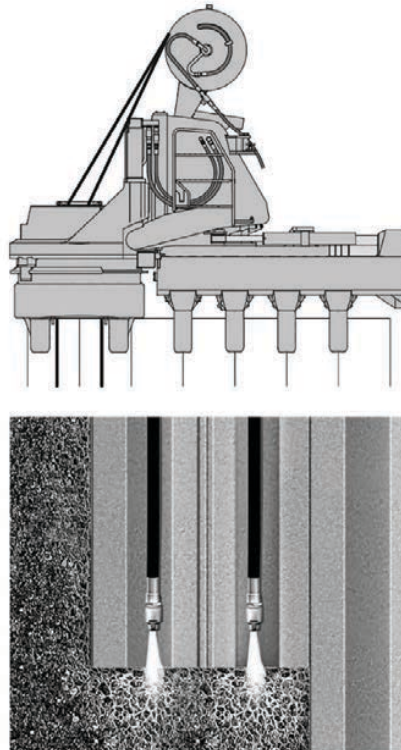

Figure 5

These systems are generally used for sandy soils or soils consisting of silty, clayey or gravelly dense sand where the SPT N value is  $[25 \leq N \leq 50]$  for sheet piles and  $[15 \leq N \leq 50]$  for pipe piles. In soils with this type of density and composition, the pile toe and interlock resistance can increase due to the consolidation of soil particles. By temporarily breaking up the soil composition around the pile toe while upstream water flow reduces skin friction and washes out soil within the pile's interlocks, water jetting systems for press-in machines can reduce pile toe and interlock resistance, thus reducing resistance and preventing potential damage to the piles being installed.

**Simultaneous augering systems** for Z-shaped sheet piles like what is shown in Figure 6 are designed to drill ahead of sheet piles while pressing in sheet piles at the same time. The image on the left in Figure 6 shows that the continuous flight auger fits into the web of the sheet pile pair being installed. The image on the right in Figure 6 illustrates what the operation looks like underground.

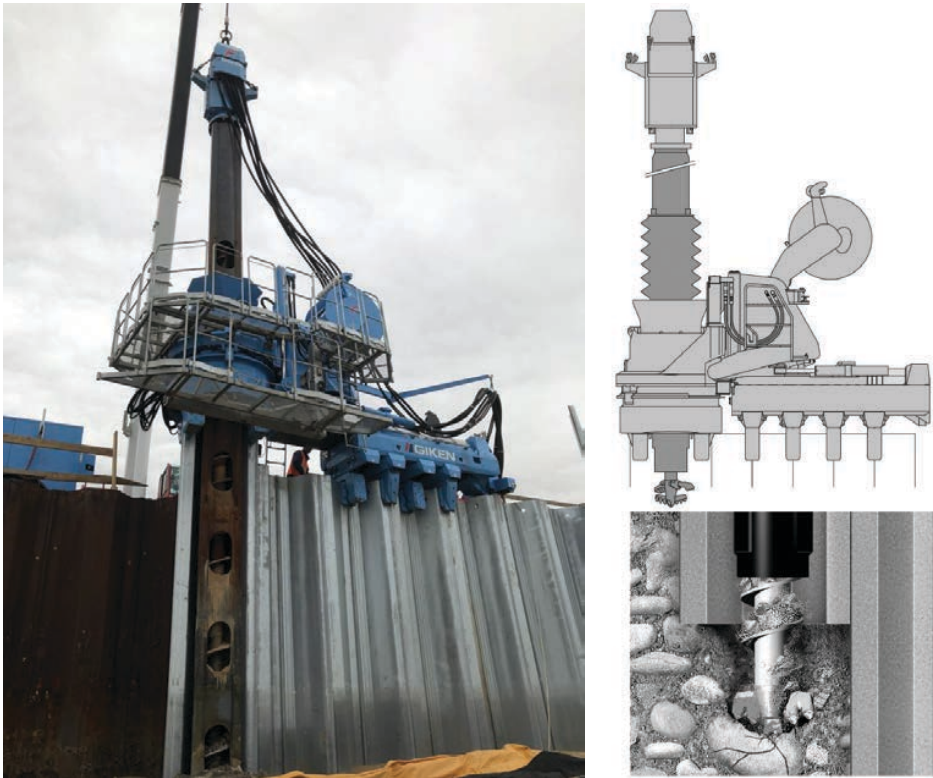

Figure 6

These systems are generally used for stiff cohesive soil, solidified sand/silt, gravels, cobbles, boulders and relatively soft rock/rock layers, etc., where the SPT N value is  $[25 \leq N < 300]$ . The drilling that takes place just below the toe of the sheet pile pair while the sheet pile pair is being pressed in at the same time prevents a pressure bulb from building up at the pile toe. Different auger head diameter sizes can be utilized depending on the soil conditions and project parameters.

**Rotary cutting systems for pipe piles**, like what is shown in Figure 7, are designed for pipe piles to core through similar soil and ground conditions as the simultaneous augering system for pressed in sheet piles. This variation of press-in piling for steel pipe piles is designed to rotate and simultaneously press pipe piles into the ground. Sacrificial cutting shoes are welded onto the toes of each pipe pile for faster pile installation into hard soil, rock and even existing concrete (Takuma et al., 2013). The bottom image within Figure 7 illustrates what the operation looks like underground.

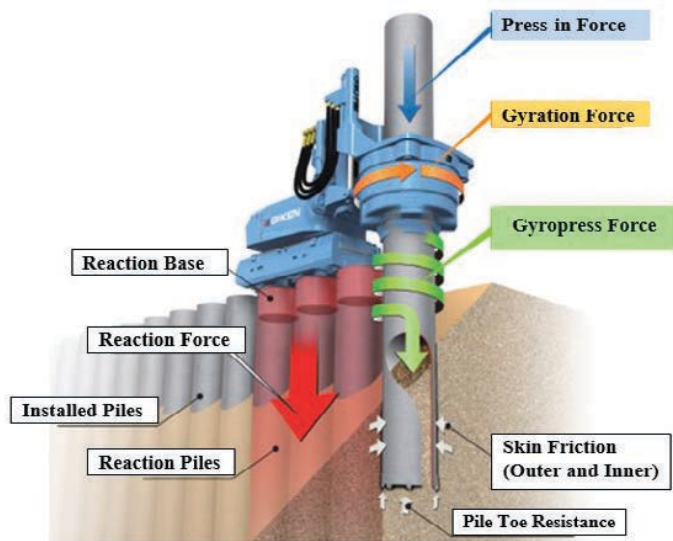

Figure 7

While long interlocking pipe piles can be pressed into dense sand with high pressure water jetting (Takuma et al., 2017), this simultaneous rotation and press-in action helps reduce press-in resistance without loosening the ground for pipe piles without interlocks. For pipe piles without interlocks, angular plates or smaller diameter pipe pile can be pressed in between the primary pipe piles for watertightness.

## Capability to install piles with very limited access

In addition to the aforementioned basic press-in piling components, a method known as the non-staging method allows for press-in machines and the equipment needed to carry out pile installation to walk or advance on top of the sheet or pipe piles being installed, which enables the equipment to operate in limited access areas where conventional pile driving equipment cannot reach. Examples of limited access areas include slope embankments or water. Figure 8 shows the equipment designed to advance atop the installed piles to complete the operation which includes the press-in machine itself, a clamp crane, a power unit and a pile runner. The pile runner is designed to bring sheet or pipe piles to the piling operation from a remote access point.

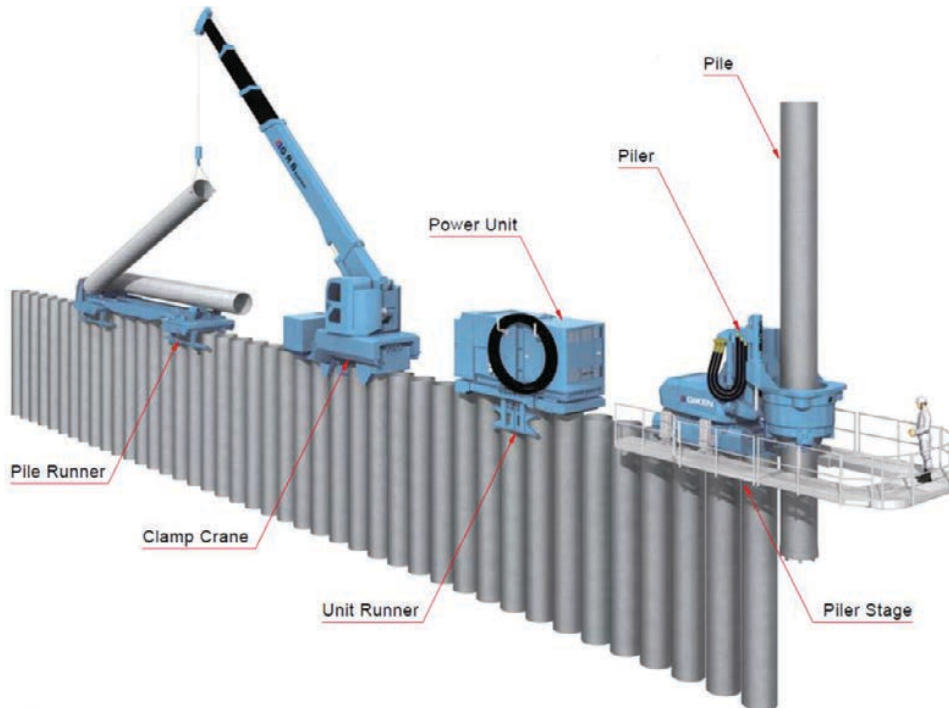

Figure 8

## Capability to install piles in low headroom

While there is conventional pile driving equipment that is able to drive piles within limited vertical clearances, press-in machines are also designed for pile installation where vertical access is limited. Figure 9 displays how press-in piling machines are able to install sheet piles within low headroom conditions. Both sheet pile and pipe pile press-in machines can install within 13 feet of headroom, although there are limitations for sheet pile installation within low headroom conditions depending on the density of the soil that the sheet piles will be pressed into.

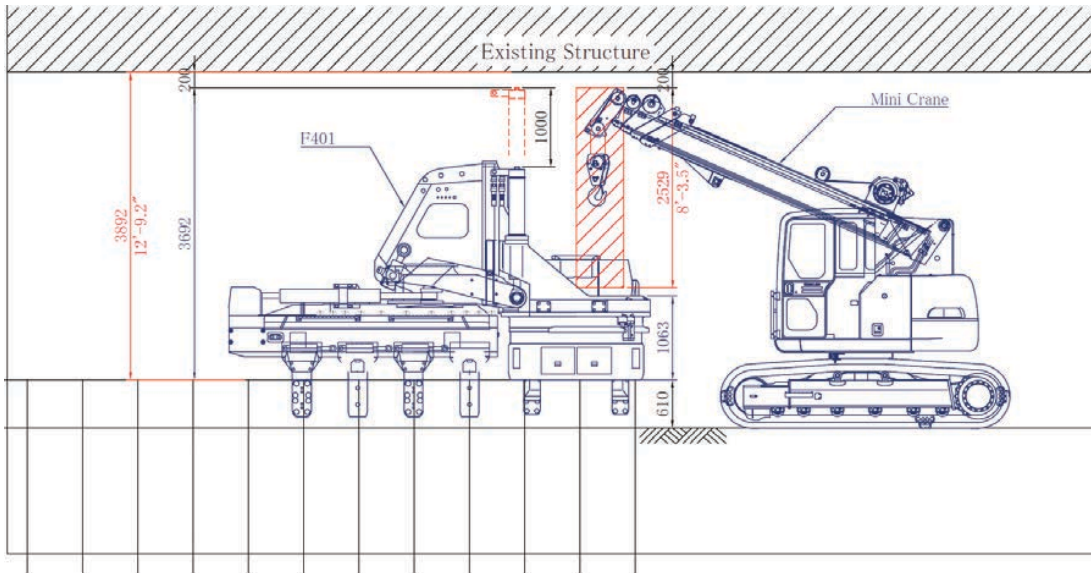

Figure 9

## Press-in monitoring system

Another notable advantage of press-in machines is that with each pile pressed into the ground with an electronically controlled static load by using a series of hydraulics, real time conditions, skin friction, toe resistance, penetration depth and operation time of the press-in force can be monitored. These readings can also help determine axial load capacities during press-in pile installation, hence their advantageous use for the installation of vertical load-bearing piles. This monitoring is described through the illustration in Figure 10 below.

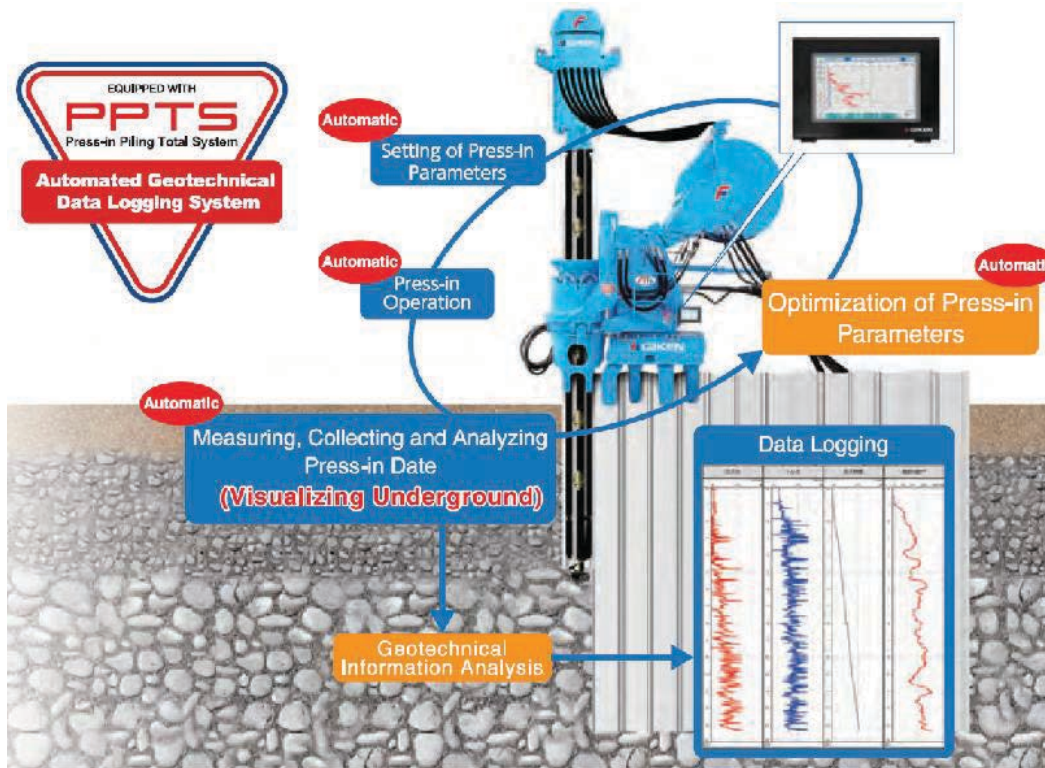

Figure 10

## References

- Takuma, T., Nishimura, H., (2017), "Deep Pipe Pile Cell Foundations Built in Rivers for Expressway Viaduct Widening," *Proceedings of 2017 International Bridge Conference (IBC 17-17)*
- Takuma, T., Nishimura, H., Kambe, S., (2013). "Low noise and low vibration tube pile installation by the press-in piling method," *Proceedings of 2013 Annual Conference of Deep Foundations*
- White, D., Finlay, T., Bolton, M., and Bearss, G. (2002). "Press-in Piling: Ground Vibration and Noise during Piling Installation," *Proceedings of the International Deep Foundation Congress, ASCE Special Publication 116.*

The following PDCA members contributed to the information included in this Hammer Database and Guidance document:

**American Piledriving Equipment, Inc.**

7032 South 196th St.  
Kent, WA 98032  
Contact: Steve Cress  
Office: 800-248-8498  
Mobile: 206-743-2846  
Email: [stevec@americanpiledriving.com](mailto:stevec@americanpiledriving.com)  
[www.americanpiledriving.com](http://www.americanpiledriving.com)

**Dieseko / PVE**

5011 Vernon Rd.  
Jacksonville, FL 32209  
Contact: Herald Wattenberg  
Mobile: 904-765-8868  
Email: [herald@pveusa.com](mailto:herald@pveusa.com)  
[www.pveusa.com](http://www.pveusa.com)

**Giken America Corp.**

Contact: Ian Vaz  
Mobile: 407-666-8119  
[www.giken.com](http://www.giken.com)  
  
New York City Office  
One Grand Central Place  
60 East 42nd St., Suite 3030  
New York, NY 10165  
Office: 212-597-9331  
  
Orlando Office  
5850 T.G. Lee Blvd., Suite 535  
Orlando, FL 32822  
Ofce: 407-380-3232

---

The following companies provided additional contributions:

**Dawson Construction Plant, Inc.**

Kansas City, MO  
Contact: Tim Williamson  
Mobile: 816-808-8815  
Email: [timw@dcpuk.com](mailto:timw@dcpuk.com)

**International Attachments Inc.**

3030 Rocky Point Dr.  
Tampa, FL 33607  
Contact: Warren Smith, President  
Office: 877-219-1962  
Email: [warren@iai-usa.com](mailto:warren@iai-usa.com)  
[www.iai-usa.com](http://www.iai-usa.com)

**Movax Oy**

Tölkkimäentie 10  
FI-13130 Hämeenlinna  
Finland  
Contact: Lasse Mannola, Managing Director  
Mobile: +358 45 604 7944  
Email: [lasse.mannola@movax.fi](mailto:lasse.mannola@movax.fi)  
[www.movax.com](http://www.movax.com)



Client IPC and MIMC Job Number 11215702 Sheet \_\_\_\_\_  
Project San Jacinto River Waste Pits Site Sheets By S.Chilka Date 11-22-2024  
Subject Velocity Buoy Data Processing Checked By \_\_\_\_\_ Date \_\_\_\_\_

APPENDIX I - BMP STRUCTURAL DESIGN REPORT  
**ATTACHMENT 3.8**  
**VELOCITY BUOY DATA PROCESSING**



# Technical Memorandum

November 19, 2024

<b>To</b>	File	<b>Contact No.</b>	925 849 1019
<b>Copy to</b>	Lee Lavergne	<b>Email</b>	satish.chilka@ghd.com
<b>From</b>	Mazen Idriss, EIT, Satish Chilka, PE	<b>Project No.</b>	11215702
<b>Project Name</b>	San Jacinto River Superfund – Northern Impoundment		
<b>Subject</b>	Evaluation of velocity data collected by buoys on Site		

## 1. Introduction

An engineered cofferdam using the best management practices (BMP) will encircle the Northern Impoundment of the San Jacinto River Waste Pits Superfund (Site). A sacrificial barrier wall system on the exterior side of the BMP and the steel sheet pile walls of the BMP are designed for potential impacts resulting from a barge coming off its mooring or a towed barge veering off course. It is assumed that the barges will move at the same velocity as the flowing water.

The velocity of flow is a function of volume, depth and width of the river and varies at different locations in the San Jacinto River. The buoys – Monitor A and Monitor B were installed at the locations shown as pink dots in Figure 1 to collect velocity speed and direction however Monitor A stopped functioning. The data collected from the buoy B was evaluated to screen out outliers and determine the appropriate velocity to be used for the impact design. The following sections describe the methodology and results from the evaluation.

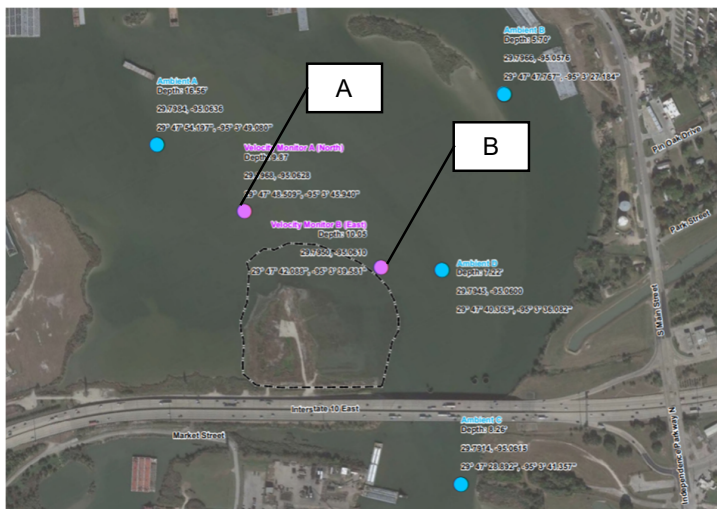

Figure 1 Location of GHD Buoys

This Technical Memorandum is provided as an interim output under our agreement with IPC and MIMC. It is provided to foster discussion in relation to technical matters associated with the project and should not be relied upon in any way.

## 2. Raw Data near Site

The buoy B records velocity data in the San Jacinto river at 10-minute intervals. Velocity data was transmitted between Jan 1, 2022, to July 26, 2024, with few interruptions. The raw data includes directionality i.e.,  $\pm X$  and  $\pm Y$  direction relative to the installed position along with the speed of flow. The location of the buoy allows capturing the site-specific velocity data, but it also makes them susceptible to interference from wakes from nearby barges and boats. Such interference can cause artificial and unrealistic spikes over consecutive data points or only lasting a short duration in the recorded dataset.

The data set comprised of 129593 velocity readings was reviewed to find such anomalies. An example of such interference is shown in Figure 2. The 5.5 ft/s difference (-1 to +4.5) between the consecutive data points is an unrealistic shift in velocity over a 10-minute period.

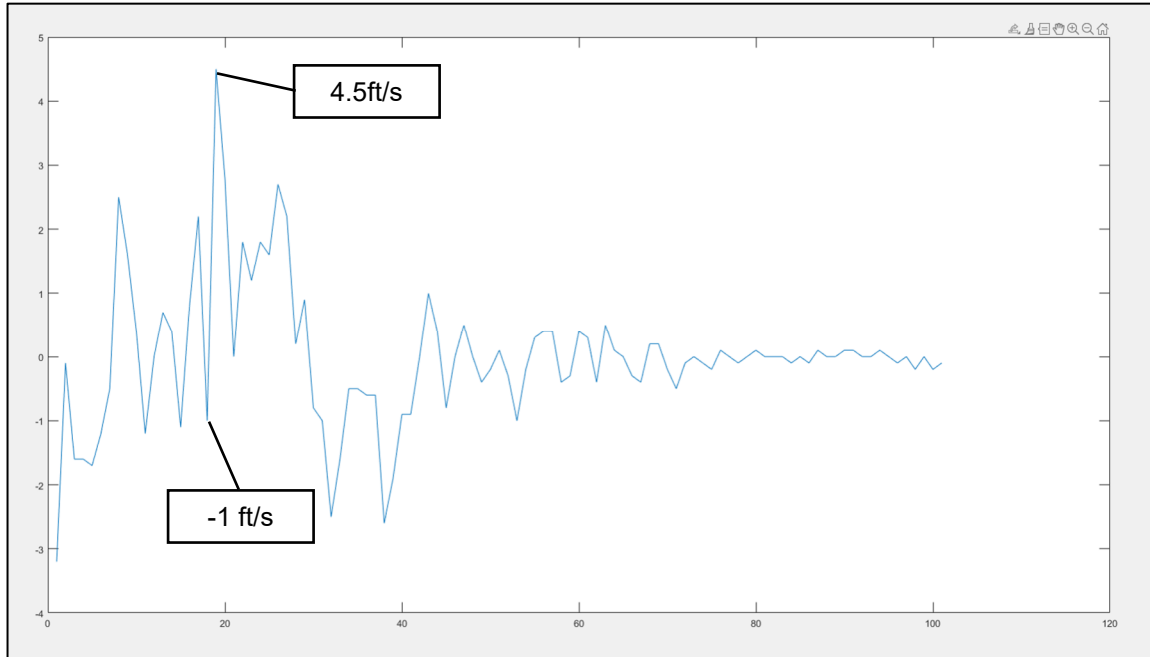

**Figure 2** Example of Short Duration Spike in Velocity Data

The difference between the consecutive points was plotted in percentile ranges to quantify the magnitude and frequency of short duration spikes in Figure 3 and Figure 4. The difference between two consecutive points is generally near zero, thus further validating the supposition that if short duration spikes were to occur in the data, it should be evaluated as an anomaly. The spikes on the left and right sides of the plot indicate that below the 1<sup>st</sup> or above the 99<sup>th</sup> percentile, spikes with an absolute value much larger than 0 occur within the dataset.

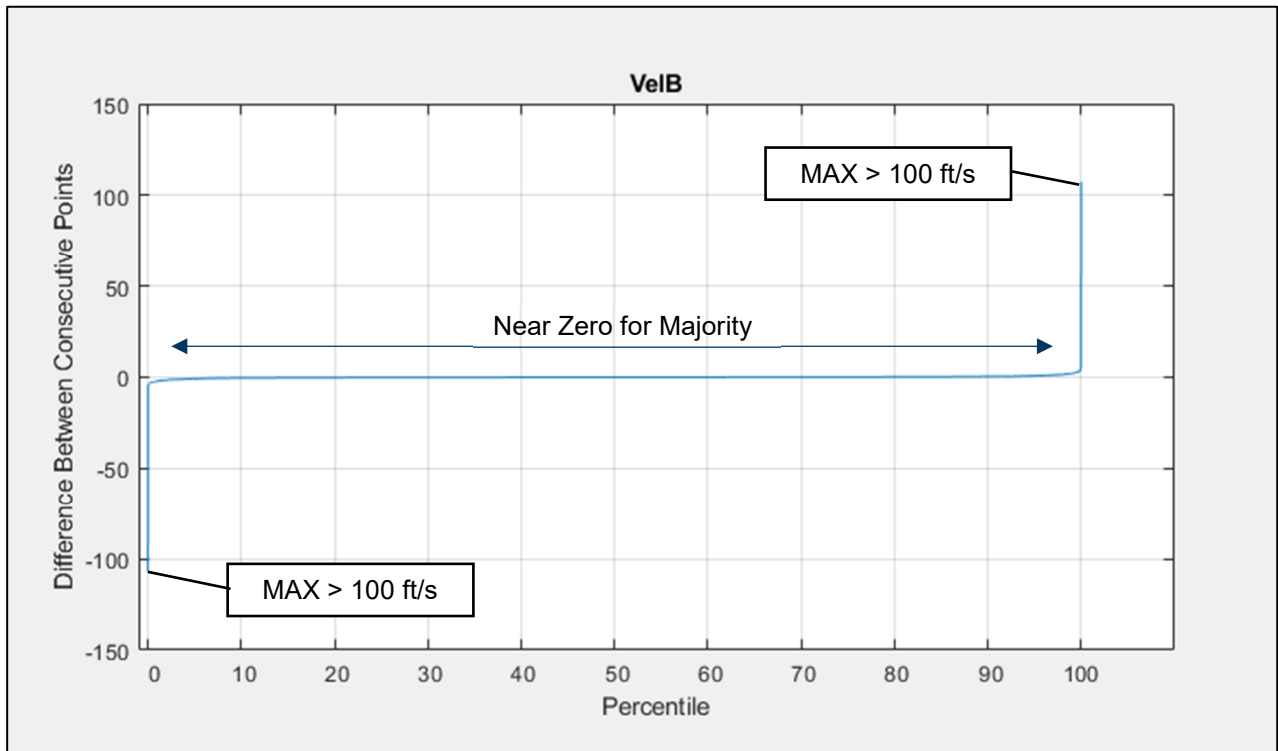

Figure 3 X-Direction Percentile Plot for Difference in Consecutive Points

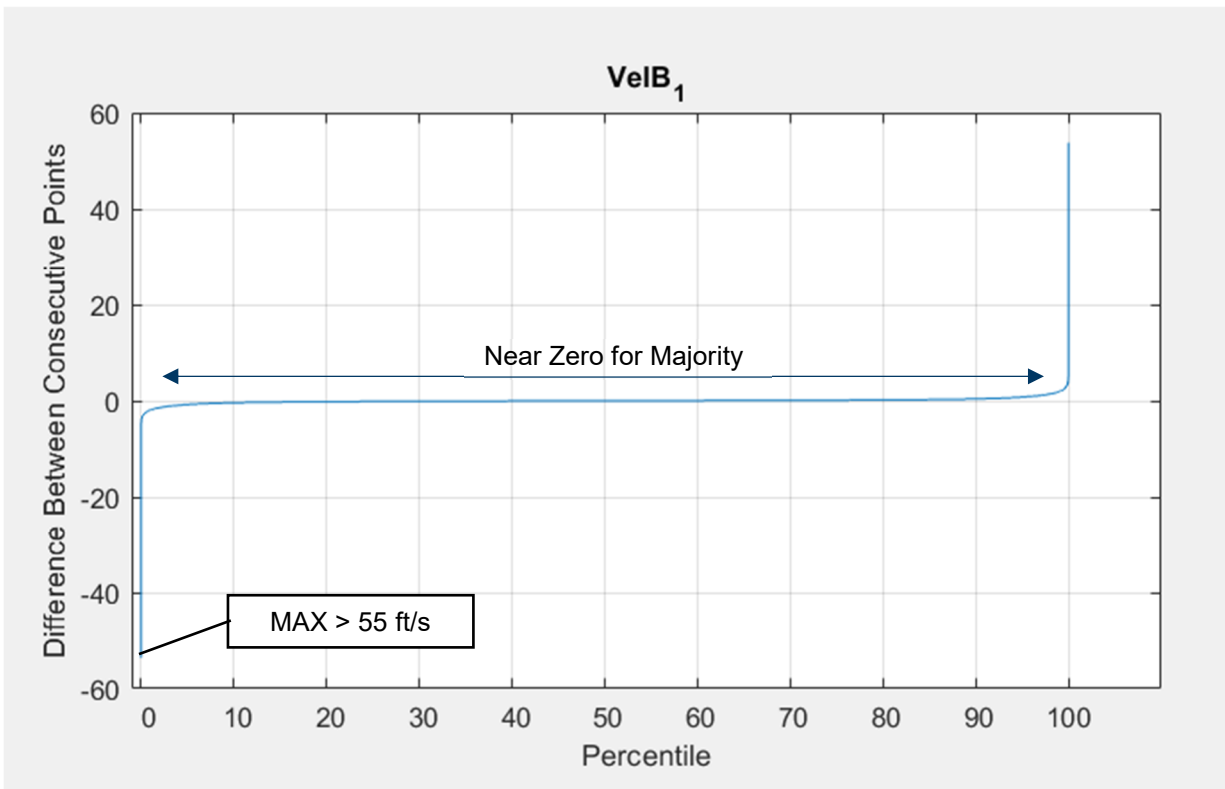

Figure 4 Y Direction Percentile Plot for Difference in Consecutive Points

This Technical Memorandum is provided as an output under our agreement with IPC and MIMC. It is provided to foster discussion in relation to technical matters associated with the project and should not be relied upon in any way other than the stated purpose.

### 3. Review of USGS Buoy Data

While a difference of 5.5 ft/s over 10-minute period (Figure 2) can be considered unreasonable, a cutoff threshold value for a larger dataset needs to be selected carefully to avoid oversimplifying the data and losing a realistic representation of the site conditions. A reasonable approach to select the threshold value can be derived by evaluating the published data from other locations.

USGS<sup>1</sup> and NOAA<sup>2</sup> own, operate and maintain several buoys across the United States. These agencies constantly evaluate the collected data and automatically flag inconsistencies. NOAA has also published their techniques<sup>3</sup> for processing different type of data and use the following equation:

$$\left| \frac{x(t+T) - x(t)}{T} \right| \leq k(T)T$$

Where  $x(t+T)$  and  $x(t)$  are consecutive datapoints separated in time by  $T$  seconds.  $k(T)T$  is either a function or a constant that is determined empirically. If the equation is true, then the data passes the quality control check.

USGS manages a buoy in the San Jacinto River, upstream of the Site, near Sheldon, Texas (Site ID 08072050). The data from the Sheldon buoy was reviewed over the same time period of data collected by the buoy on Site to determine the  $k(T)T$  factor.

The difference between two consecutive points organized by percentile at the Sheldon buoy is shown in Figure 5. The difference between two consecutive data points for majority of the dataset is less than 0.2 ft/s and the maximum difference is 0.88 ft/sec.

It is important to note the location of the buoy, channel width and water depth affect the velocity measured in the river. The Sheldon buoy is located in an area relatively less influenced by tides and the velocity measurements are in a narrower channel. As the buoy B on the Site are closer to a wider body of water, the velocity data is less sensitive to impacts from surface runoff and storm events than the Sheldon site. Therefore contributing to a lower variability in velocity. The maximum difference at Sheldon buoy can be taken as a conservative cutoff threshold of maximum variability for buoy on Site.

---

<sup>1</sup> United States Geological Survey

<sup>2</sup> National Oceanic and Atmospheric Administration

<sup>3</sup> Handbook of Automated Data Quality Control Checks and Procedures, NOAA (2009)

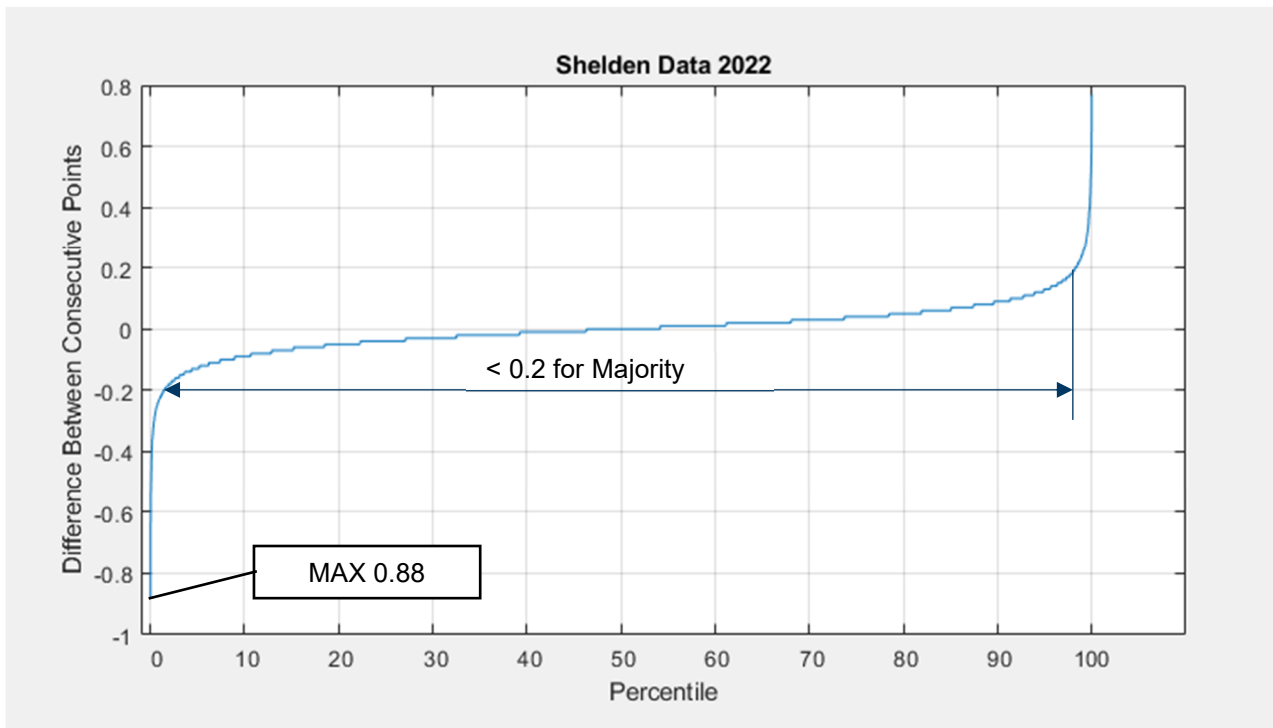

Figure 5 Shelden Buoy Percentile Plot for Difference in Consecutive Points

#### 4. Processed Data near Site

The raw data from the buoy on Site is filtered using the maximum difference observed from the Sheldon site as the cutoff threshold. Every data point that differed more than 0.88 ft/s from the adjacent data point was removed from the dataset. The difference between the consecutive points in the processed dataset was replotted in percentile ranges as shown in Figure 6 and Figure 7. The percentile plots are comparable to the percentile plot from Sheldon buoy shown in Figure 5 and does not indicate presence of many short duration spikes.

This Technical Memorandum is provided as an output under our agreement with IPC and MIMC. It is provided to foster discussion in relation to technical matters associated with the project and should not be relied upon in any way other than the stated purpose.

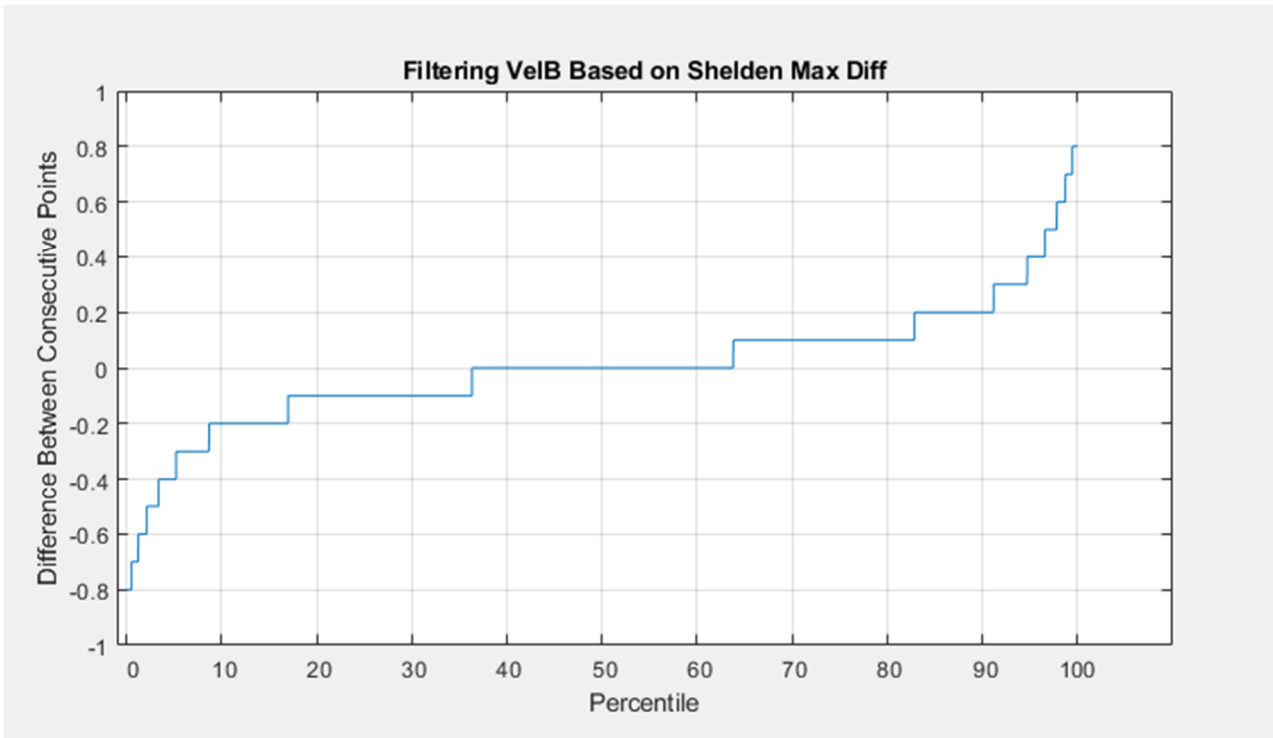

Figure 6 X-Direction Percentile Plot – Filtered Difference in Consecutive Points

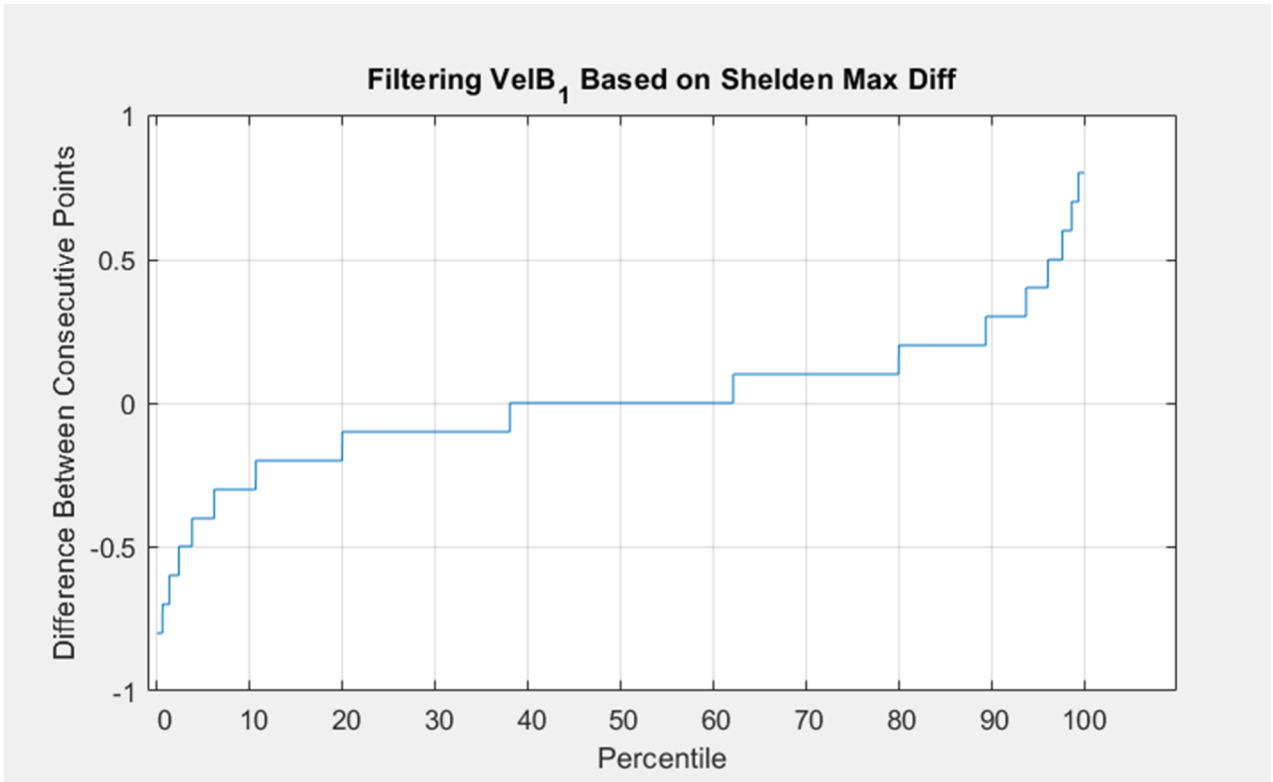

Figure 7 Y-Direction Percentile Plot – Filtered Difference in Consecutive Points

This Technical Memorandum is provided as an output under our agreement with IPC and MIMC. It is provided to foster discussion in relation to technical matters associated with the project and should not be relied upon in any way other than the stated purpose.

## 4.1 X-Direction Velocity Time Series

Figure 8 shows the X direction velocity data from the buoy at different stages of the validation. The velocity is plotted on the y-axis and the +/- value represent directionality of the datapoint i.e., flow along +X or -X direction.

The first plot is the raw data with all spikes and anomalies included. The values along y-axis are quite large to capture the large spikes in the data. The second plot is the auto-filtered time series with the differences between consecutive data points limited to 0.88 ft/s as described in Section 4. The third plot is the same as the second, but five (5) individual data points that still seemed to be large outliers were manually removed from the dataset.

After the first filter, there were eight (8) outliers where difference between consecutive points was still significantly greater than the cutoff value and five (5) of those points were manually filtered from the dataset to find the representative velocity in the X direction. See Figure 9.

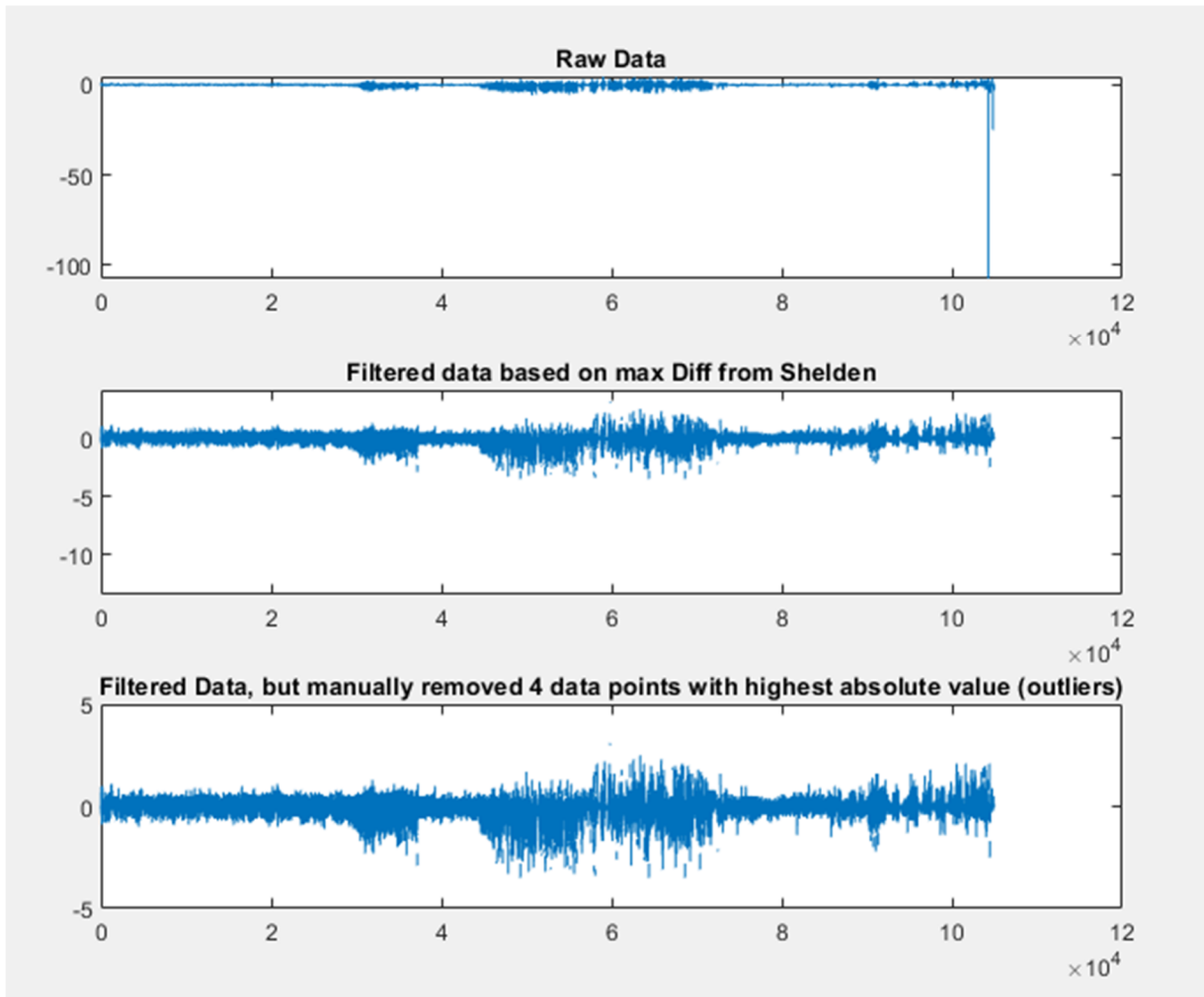

Figure 8 X-Direction Velocity Time Series

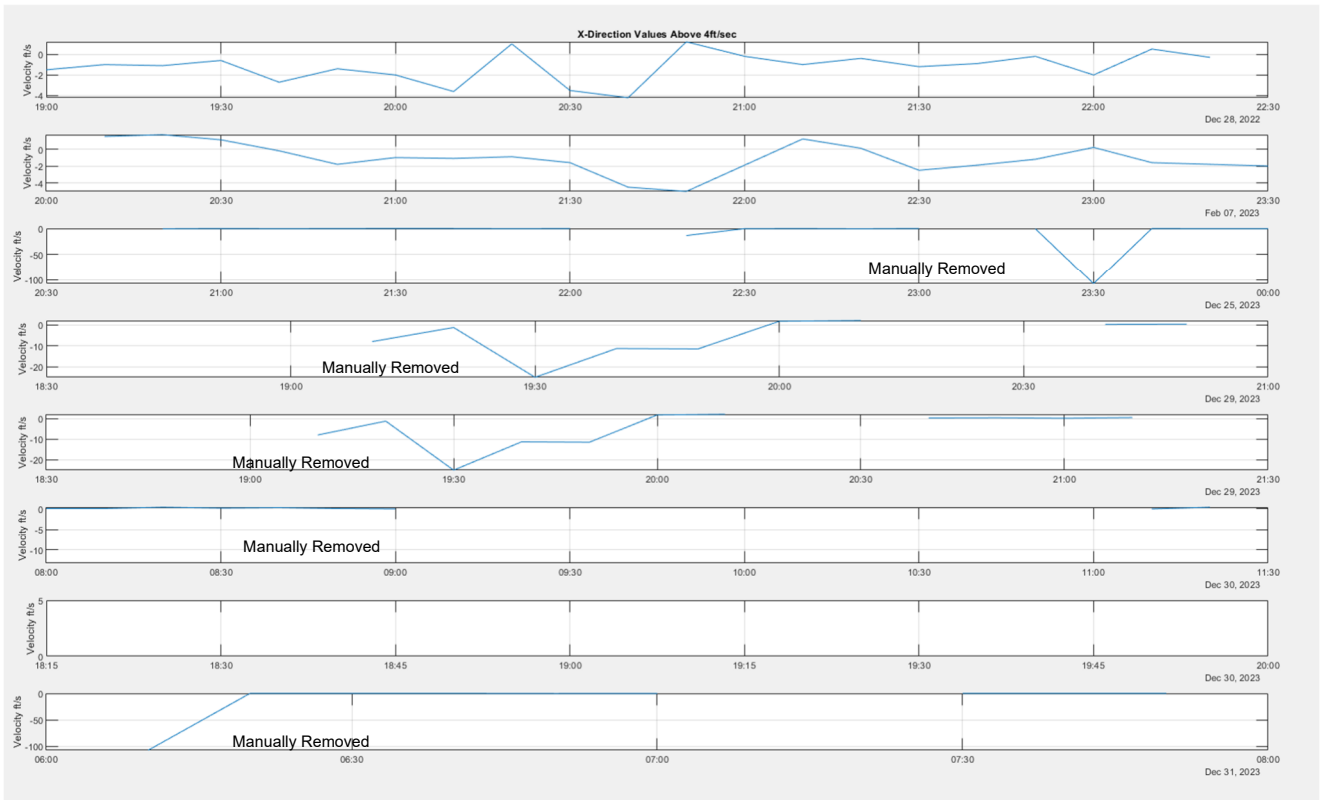

Figure 9 X-Direction Time Series – Outliers after Auto-Filter

## 4.2 Y-Direction Velocity Time Series

Figure 10 shows the Y direction velocity data from the buoy at different stages of the validation. The velocity is plotted on the y-axis and the +/- value represent directionality of the datapoint i.e., flow along +Y or -Y direction. The first plot is the raw data with all spikes and anomalies included. The values along y-axis are quite large to capture the large spikes in the data. The second plot is the filtered time series with the differences between consecutive data points limited to 0.88 ft/s as described in Section 4. The third plot is the same as the second, but two (2) individual values were removed manually.

After the first filter, there were ten (10) outliers where difference between consecutive points was still significantly greater than the cutoff value and two (2) of those points were manually filtered from the dataset to find the representative velocity in the X direction. See Figure 11.

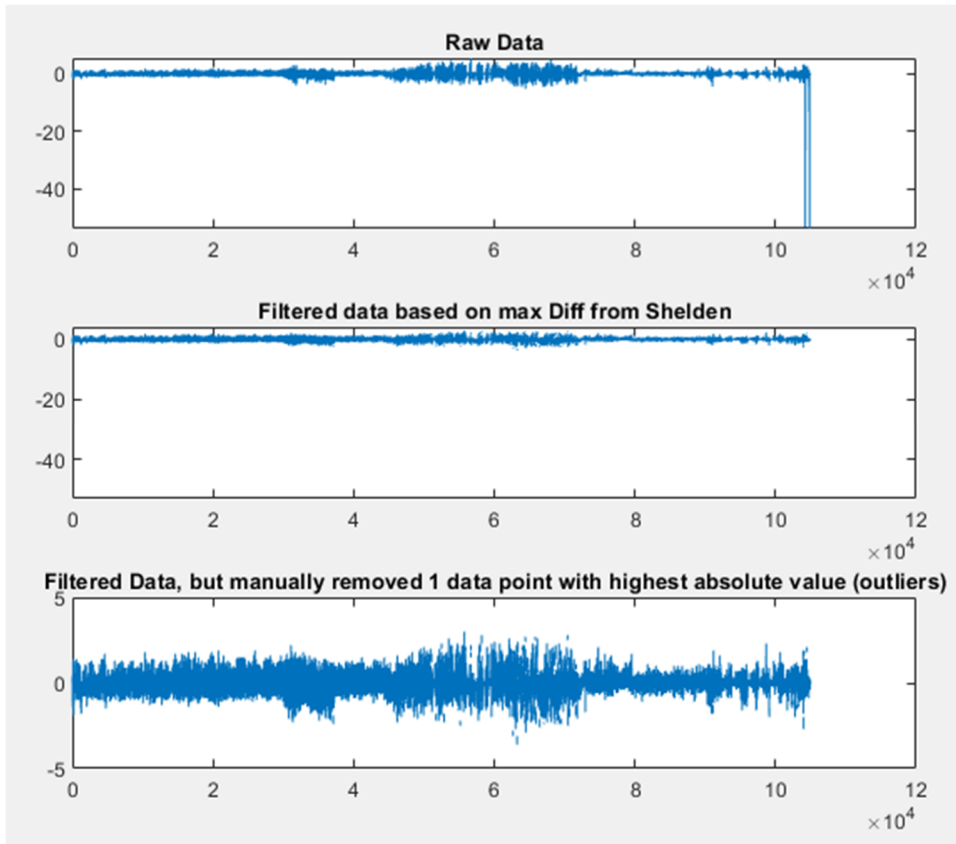

Figure 10 Y-direction Velocity Time Series

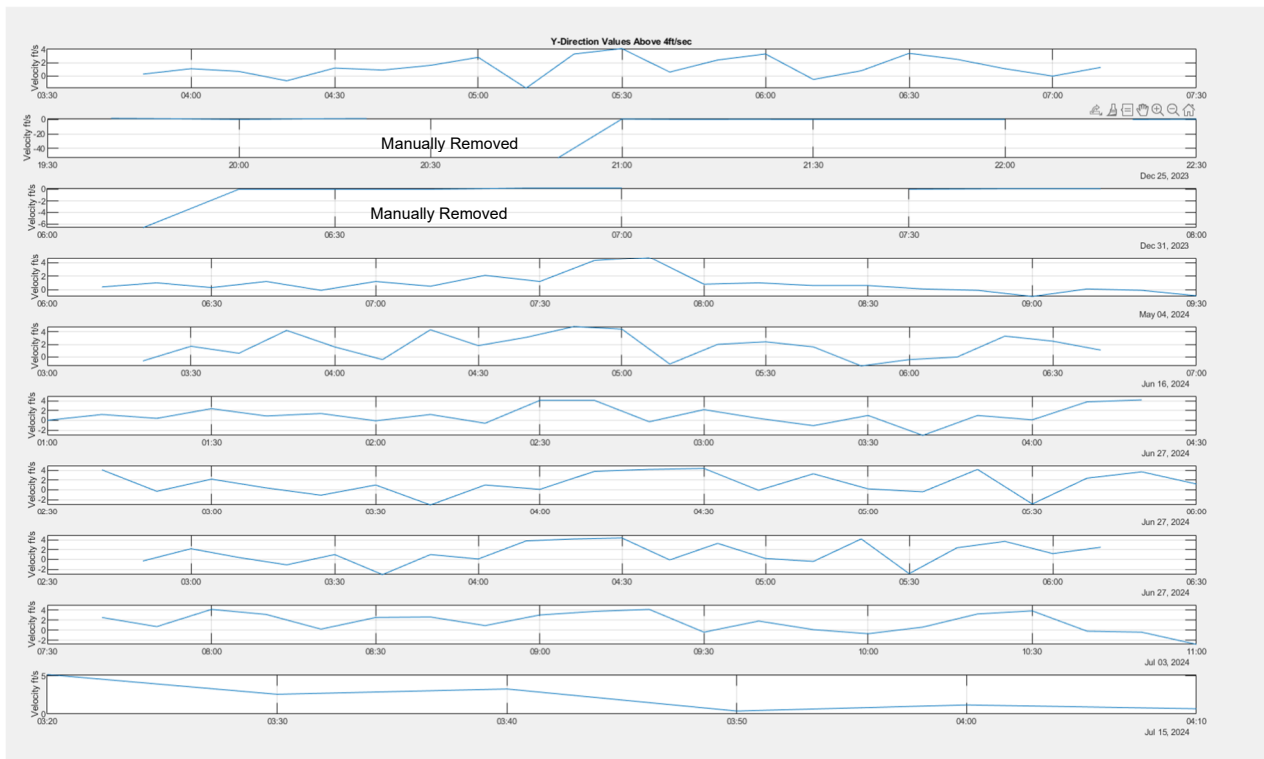

Figure 11 Y-Direction Time Series – Outliers after Auto-Filter

This Technical Memorandum is provided as an output under our agreement with IPC and MIMC. It is provided to foster discussion in relation to technical matters associated with the project and should not be relied upon in any way other than the stated purpose.

## 5. Statistical Evaluation

The max, 90<sup>th</sup>, and 95<sup>th</sup> percentiles of the absolute value of the velocities for step described in Section 4 is summarized in Table 1. The table also lists the number of individual instances (10-minute data point) above an absolute value of 4 ft/s.

Note that the dataset comprised of 129593 observations (900 days). The sum of 167 instances exceeding 4 ft/s accounted for 0.13% of dataset in the raw data for Y-direction.

Based on the data evaluated from site-specific velocity records, 4 ft/s is an appropriate value to be used for barge impact assessment.

*Table 1 Summary of velocity values with each technique*

Buoy Data	X Direction Velocity (ft/s)			Y Direction Velocity (ft/s)		
	Raw	Auto-Filtered	Filtered + Manual Removals	Raw	Auto-Filtered	Filtered + Manual Removals
<b>90<sup>th</sup> Percentile</b>	0.9	0.6	0.6	1.1	0.9	0.9
<b>95<sup>th</sup> Percentile</b>	1.4	0.9	0.9	1.5	1.1	1.1
<b>Absolute Max Value</b>	107.4	107.4	5	53.6	53	5.2
<b>Count &gt; 4 ft/s (% Total Observations)</b>	80 (0.06 %)	8 (0.006 %)	3 (0.002 %)	167 (0.13 %)	10 (0.008 %)	8 (0.006 %)











































Site Time	Velocity A		Velocity B	
	Vel.x ft/s	Vel.y ft/s	Vel.x ft/s	Vel.y ft/s
America/Chicago				
1/31/2022 8:00	0.2	-0.1	0.4	-0.5
1/31/2022 8:10	0.3	-0.2	0.4	-0.5
1/31/2022 8:20	0.1	-0.2	0.4	-0.3
1/31/2022 8:30	0.3	-0.2	0.4	-0.4
1/31/2022 8:40	0.1	-0.1	0.3	-0.4
1/31/2022 8:50	0.1	-0.3	0.4	-0.4
1/31/2022 9:00	0.1	-0.1	0.3	-0.5
1/31/2022 9:10	0.2	-0.1	0.3	-0.5
1/31/2022 9:20	0.2	-0.2	0.3	-0.4
1/31/2022 9:30	0.2	-0.2	0.5	-0.4
1/31/2022 9:40	0.2	-0.1	0.3	-0.5
1/31/2022 9:50	0.3	-0.2	0.3	-0.5
1/31/2022 10:00	0.2	-0.2	0.4	-0.2
1/31/2022 10:10	0.1	-0.2	0.2	-0.3
1/31/2022 10:20	0.3	-0.2	0.2	-0.5
1/31/2022 10:30	0.3	-0.1	0.2	-0.4
1/31/2022 10:40	0.2	-0.2	0.2	-0.4
1/31/2022 10:50	0.3	-0.2	0.2	-0.4
1/31/2022 11:00	0.2	-0.1	0.2	-0.3
1/31/2022 11:10	0.2	-0.1	0.2	-0.4
1/31/2022 11:20	0.1	-0.1	0.1	-0.1
1/31/2022 11:30	0	-0.1	0.2	-0.2
1/31/2022 11:40	0	-0.1	0.1	-0.3
1/31/2022 11:50	-0.2	0.1	-0.1	-0.4
1/31/2022 12:00	0	-0.1	0.5	-0.5
1/31/2022 12:10	0.1	-0.2	0.3	-0.5
1/31/2022 12:20	0.1	-0.2	0.3	-0.3
1/31/2022 12:30	0.3	-0.1	0.4	-0.3
1/31/2022 12:40	0.2	-0.2	0.2	0
1/31/2022 12:50	0.3	-0.2	0.2	-0.1
1/31/2022 13:00	0.1	0	0.1	-0.2
1/31/2022 13:10	0	0.1	-0.1	0.2
1/31/2022 13:20	0.1	-0.1	-0.1	0.1
1/31/2022 13:30	0	0.1	0.1	0.2
1/31/2022 13:40	0	0	-0.2	0
1/31/2022 13:50	0	-0.1	0.1	-0.1
1/31/2022 14:00	0.1	0.1	0.3	-0.4
1/31/2022 14:10	0.1	0	0.4	-0.2
1/31/2022 14:20	0.2	0	0.4	-0.5
1/31/2022 14:30	0.1	0	0.3	-0.2
1/31/2022 14:40	0.1	0	0.1	-0.3
1/31/2022 14:50	0.2	0	0.2	-0.1
1/31/2022 15:00	0	0.1	0	0.1
1/31/2022 15:10	-0.1	0.1	-0.2	0.5
1/31/2022 15:20	0	0.1	-0.2	0.4
1/31/2022 15:30	-0.2	0.2	-0.2	0.6
1/31/2022 15:40	-0.3	0.2	-0.2	0.6
1/31/2022 15:50	-0.3	0.1	-0.2	0.6
1/31/2022 16:00	-0.3	0.1	-0.3	0.2
1/31/2022 16:10	-0.3	0.3	-0.4	0.6
1/31/2022 16:20	-0.6	0.6	-0.5	0.4
1/31/2022 16:30	-0.3	0.3	-0.5	0.3

Site Time	Velocity A		Velocity B	
	Vel.x ft/s	Vel.y ft/s	Vel.x ft/s	Vel.y ft/s
America/Chicago				
1/31/2022 16:40	-0.8	0.3	-0.4	0.4
1/31/2022 16:50	-0.3	0.5	-0.4	0.3
1/31/2022 17:00	-0.4	0.2	-0.5	0.5
1/31/2022 17:10	-0.4	0.3	-0.6	0.4
1/31/2022 17:20	-0.3	0.3	-0.4	0.6
1/31/2022 17:30	-0.4	0.6	-0.8	0.6
1/31/2022 17:40	-0.4	0.4	-0.6	1
1/31/2022 17:50	-0.4	0.5	-0.7	1
1/31/2022 18:00	-0.5	0.5	-0.9	1.3
1/31/2022 18:10	-0.4	0.6	-0.7	1.2
1/31/2022 18:20	-0.6	0.6	-0.7	1.4
1/31/2022 18:30	-0.6	0.6	-1	1.1
1/31/2022 18:40	-0.4	0.4	-0.6	1.1
1/31/2022 18:50	-0.2	0.7	-0.6	1.1
1/31/2022 19:00	-0.1	0.5	-0.8	1.3
1/31/2022 19:10	-0.2	0.5	-0.7	1.4
1/31/2022 19:20	-0.2	0.4	-0.7	1.2
1/31/2022 19:30	-0.2	0.5	-0.6	1.2
1/31/2022 19:40	-0.1	0.4	-0.5	1.2
1/31/2022 19:50	0	0.3	-0.6	1
1/31/2022 20:00	0.1	0.2	-0.7	0.8
1/31/2022 20:10	0.1	0.1	-0.2	0.6
1/31/2022 20:20	0.1	0.1	-0.3	0.7
1/31/2022 20:30	0	0.1	-0.3	0.4
1/31/2022 20:40	0	0.1	-0.2	0.7
1/31/2022 20:50	0.1	0	0	0.4
1/31/2022 21:00	0.1	0.1	0	0.1
1/31/2022 21:10	0.1	0.1	-0.2	0.2
1/31/2022 21:20	0	0	0	0.1
1/31/2022 21:30	0	0.2	-0.2	0.2
1/31/2022 21:40	0	0	0	0.2
1/31/2022 21:50	0	-0.1	-0.1	0.2
1/31/2022 22:00	0.1	-0.1	0	0.2
1/31/2022 22:10	0.1	-0.2	0	0.1
1/31/2022 22:20	0.1	0	-0.1	0.1
1/31/2022 22:30	0	-0.1	0.1	0
1/31/2022 22:40	0.2	-0.1	0	-0.1
1/31/2022 22:50	0.3	-0.3	0	-0.2
1/31/2022 23:00	0.2	-0.2	0.1	-0.3
1/31/2022 23:10	0.1	-0.1	0.2	-0.2
1/31/2022 23:20	0.1	-0.2	0.4	-0.3
1/31/2022 23:30	0.2	-0.1	0.2	-0.2
1/31/2022 23:40	0.1	-0.1	0.1	-0.3
1/31/2022 23:50	0	0	0.1	-0.1

Site Time	Velocity A		Velocity B	
	Vel.x ft/s	Vel.y ft/s	Vel.x ft/s	Vel.y ft/s
America/Chicago				

Site Time	Velocity A		Velocity B	
	Vel.x ft/s	Vel.y ft/s	Vel.x ft/s	Vel.y ft/s
America/Chicago				











































































































































































































Table with 5 columns: Site, Time, Velocity A (Vel.x, Vel.y), and Velocity B (Vel.x, Vel.y). Rows include data for 6/24/2022 from 2:40 to 11:10.

Table with 5 columns: Site, Time, Velocity A (Vel.x, Vel.y), and Velocity B (Vel.x, Vel.y). Rows include data for 6/24/2022 from 11:20 to 19:50.

Table with 5 columns: Site, Time, Velocity A (Vel.x, Vel.y), and Velocity B (Vel.x, Vel.y). Rows include data for 6/24/2022 from 20:00 to 23:50 and 6/25/2022 from 0:00 to 4:30.

Table with 5 columns: Site, Time, Velocity A (Vel.x, Vel.y), and Velocity B (Vel.x, Vel.y). Rows include data for 6/25/2022 from 4:40 to 13:10.



















































Table with columns: Site, Time, Velocity A (Vel.x, Vel.y), Velocity B (Vel.x, Vel.y). Rows range from 7/31/2022 8:00 to 7/31/2022 16:30.

Table with columns: Site, Time, Velocity A (Vel.x, Vel.y), Velocity B (Vel.x, Vel.y). Rows range from 7/31/2022 16:40 to 7/31/2022 23:50.

Table with columns: Site, Time, Velocity A (Vel.x, Vel.y), Velocity B (Vel.x, Vel.y). Rows are empty.

Table with columns: Site, Time, Velocity A (Vel.x, Vel.y), Velocity B (Vel.x, Vel.y). Rows are empty.





































































































Table with 5 columns: Site, Time, Velocity A (Vel.x, Vel.y), Velocity B (Vel.x, Vel.y). Data spans from 10/11/2022 2:40 to 10/11/2022 11:10.

Table with 5 columns: Site, Time, Velocity A (Vel.x, Vel.y), Velocity B (Vel.x, Vel.y). Data spans from 10/11/2022 11:20 to 10/11/2022 19:50.

Table with 5 columns: Site, Time, Velocity A (Vel.x, Vel.y), Velocity B (Vel.x, Vel.y). Data spans from 10/11/2022 20:00 to 10/12/2022 4:30.

Table with 5 columns: Site, Time, Velocity A (Vel.x, Vel.y), Velocity B (Vel.x, Vel.y). Data spans from 10/12/2022 4:40 to 10/12/2022 13:10.























































Table with 5 columns: Site, Time, Velocity A (Vel.x, Vel.y), Velocity B (Vel.x, Vel.y). Rows cover dates from 11/19/2022 17:40 to 11/20/2022 2:10.

Table with 5 columns: Site, Time, Velocity A (Vel.x, Vel.y), Velocity B (Vel.x, Vel.y). Rows cover dates from 11/20/2022 2:20 to 11/20/2022 10:50.

Table with 5 columns: Site, Time, Velocity A (Vel.x, Vel.y), Velocity B (Vel.x, Vel.y). Rows cover dates from 11/20/2022 11:00 to 11/20/2022 19:30.

Table with 5 columns: Site, Time, Velocity A (Vel.x, Vel.y), Velocity B (Vel.x, Vel.y). Rows cover dates from 11/20/2022 19:40 to 11/21/2022 4:10.





































































































Site Time America/Chicago	Velocity A		Velocity B	
	Vel.x ft/s	Vel.y ft/s	Vel.x ft/s	Vel.y ft/s
1/31/2023 8:00			-0.2	0.1
1/31/2023 8:10			0.1	-0.6
1/31/2023 8:20			0.1	-0.1
1/31/2023 8:30			0	-0.5
1/31/2023 8:40			-0.1	-0.2
1/31/2023 8:50			-0.1	0.3
1/31/2023 9:00			0.4	-0.1
1/31/2023 9:10			0.1	0
1/31/2023 9:20			0	-0.3
1/31/2023 9:30			0	-0.5
1/31/2023 9:40			0	0.1
1/31/2023 9:50			0	-0.1
1/31/2023 10:00			0.1	0
1/31/2023 10:10			0.2	-0.1
1/31/2023 10:20			-0.1	-0.2
1/31/2023 10:30			0	-0.2
1/31/2023 10:40			0	-0.6
1/31/2023 10:50			0	0.1
1/31/2023 11:00			0.1	-0.1
1/31/2023 11:10			0	-0.2
1/31/2023 11:20			0.1	-0.3
1/31/2023 11:30			0	0
1/31/2023 11:40			0	0
1/31/2023 11:50			0	-0.3
1/31/2023 12:00			0	0.1
1/31/2023 12:10			0	-0.1
1/31/2023 12:20			0	-0.1
1/31/2023 12:30			0	-0.1
1/31/2023 12:40			0.1	-0.2
1/31/2023 12:50			0	0
1/31/2023 13:00			-0.1	0.1
1/31/2023 13:10			-0.1	-0.1
1/31/2023 13:20			0	-0.5
1/31/2023 13:30			0.1	-0.1
1/31/2023 13:40			0.1	-0.4
1/31/2023 13:50			0	-0.1
1/31/2023 14:00			0	-0.3
1/31/2023 14:10			0	0
1/31/2023 14:20			0	0
1/31/2023 14:30			0	-0.2
1/31/2023 14:40			0	-0.2
1/31/2023 14:50			0	-0.1
1/31/2023 15:00			0.1	-0.1
1/31/2023 15:10			-0.1	-0.1
1/31/2023 15:20			0	0
1/31/2023 15:30			0	-0.3
1/31/2023 15:40			0	-0.1
1/31/2023 15:50			0	-0.1
1/31/2023 16:00			-0.1	-0.2
1/31/2023 16:10			-0.1	-0.2
1/31/2023 16:20			-0.1	-0.6
1/31/2023 16:30			-0.1	-0.2

Site Time America/Chicago	Velocity A		Velocity B	
	Vel.x ft/s	Vel.y ft/s	Vel.x ft/s	Vel.y ft/s
1/31/2023 16:40			0.2	0
1/31/2023 16:50			0	-0.9
1/31/2023 17:00			-0.1	-0.4
1/31/2023 17:10			-0.1	-0.7
1/31/2023 17:20			0	0
1/31/2023 17:30			-0.2	-0.8
1/31/2023 17:40			-0.1	-0.3
1/31/2023 17:50			-0.4	-1
1/31/2023 18:00			0	-0.5
1/31/2023 18:10			0.4	-0.6
1/31/2023 18:20			0.2	-0.3
1/31/2023 18:30			-0.2	-1.4
1/31/2023 18:40			0	-0.1
1/31/2023 18:50			-0.1	-1.2
1/31/2023 19:00			-0.7	-0.3
1/31/2023 19:10			0.3	-0.4
1/31/2023 19:20			0.1	0.1
1/31/2023 19:30			0	0
1/31/2023 19:40			-0.1	0.1
1/31/2023 19:50			0.3	0.6
1/31/2023 20:00			-0.2	-2
1/31/2023 20:10			0.4	-0.3
1/31/2023 20:20			0.1	0.4
1/31/2023 20:30			-0.2	-1.3
1/31/2023 20:40			-0.4	-2.2
1/31/2023 20:50			-0.2	-1.8
1/31/2023 21:00			-0.1	-0.4
1/31/2023 21:10			0	-1.2
1/31/2023 21:20			-0.1	-1.1
1/31/2023 21:30			-0.3	-0.7
1/31/2023 21:40			0.5	-1
1/31/2023 21:50			0	-0.4
1/31/2023 22:00			-0.1	0
1/31/2023 22:10			-0.2	-2
1/31/2023 22:20			-0.2	-1.1
1/31/2023 22:30			-0.7	-1.7
1/31/2023 22:40			0	0.6
1/31/2023 22:50			-0.3	-0.9
1/31/2023 23:00			0.1	0.3
1/31/2023 23:10			0.4	-1
1/31/2023 23:20			-0.3	-0.7
1/31/2023 23:30			0.4	-0.1
1/31/2023 23:40			-0.1	-0.6
1/31/2023 23:50			-0.2	-1

Site Time America/Chicago	Velocity A		Velocity B	
	Vel.x ft/s	Vel.y ft/s	Vel.x ft/s	Vel.y ft/s

Site Time America/Chicago	Velocity A		Velocity B	
	Vel.x ft/s	Vel.y ft/s	Vel.x ft/s	Vel.y ft/s







































Site Time	Velocity A		Velocity B	
	Vel.x ft/s	Vel.y ft/s	Vel.x ft/s	Vel.y ft/s
America/Chicago				
2/28/2023 10:40			0	0
2/28/2023 10:50			0	0
2/28/2023 11:00			-0.3	0.5
2/28/2023 11:10			0.3	-0.2
2/28/2023 11:20			0	0.3
2/28/2023 11:30			-0.2	0.9
2/28/2023 11:40			0.4	0.4
2/28/2023 11:50			-0.5	0.6
2/28/2023 12:00			0.8	-0.8
2/28/2023 12:10			-0.3	0.7
2/28/2023 12:20			0.2	-0.2
2/28/2023 12:30			-1.2	1.4
2/28/2023 12:40			-0.9	0.7
2/28/2023 12:50			-1.3	2.1
2/28/2023 13:00			-0.3	0.5
2/28/2023 13:10			-0.3	0.1
2/28/2023 13:20			-0.1	0.8
2/28/2023 13:30			-0.5	0.2
2/28/2023 13:40			-0.3	0.2
2/28/2023 13:50			0.2	0
2/28/2023 14:00			-0.2	0
2/28/2023 14:10			-0.1	0.1
2/28/2023 14:20			0	0.2
2/28/2023 14:30			0.2	0.4
2/28/2023 14:40			-0.1	0.5
2/28/2023 14:50			-0.1	0.8
2/28/2023 15:00			0	0.6
2/28/2023 15:10			-0.2	0.9
2/28/2023 15:20			0	0.5
2/28/2023 15:30			-0.2	0.7
2/28/2023 15:40			-0.5	0.8
2/28/2023 15:50			-0.2	0.6
2/28/2023 16:00			-0.2	0.3
2/28/2023 16:10			-0.4	0.7
2/28/2023 16:20			-0.5	0.5
2/28/2023 16:30			0.4	0
2/28/2023 16:40			-0.2	0.4
2/28/2023 16:50			-0.1	0
2/28/2023 17:00			-0.6	0.8
2/28/2023 17:10			1.4	-0.1
2/28/2023 17:20			-0.6	0.8
2/28/2023 17:30			0.1	0.3
2/28/2023 17:40			-0.5	1.1
2/28/2023 17:50			-0.6	0.8
2/28/2023 18:00			-0.3	0.7
2/28/2023 18:10			0.1	0.2
2/28/2023 18:20			1.3	1.6
2/28/2023 18:30			1.8	0.6
2/28/2023 18:40			0.5	-0.5
2/28/2023 18:50			0.1	-0.2
2/28/2023 19:00			0.3	-0.6
2/28/2023 19:10			-0.1	-0.3

Site Time	Velocity A		Velocity B	
	Vel.x ft/s	Vel.y ft/s	Vel.x ft/s	Vel.y ft/s
America/Chicago				
2/28/2023 19:20			-0.1	-0.5
2/28/2023 19:30			0.6	-0.6
2/28/2023 19:40			0.2	-0.2
2/28/2023 19:50			1.5	-0.6
2/28/2023 20:00			-0.2	0
2/28/2023 20:10			1.1	0.5
2/28/2023 20:20			0	0.1
2/28/2023 20:30			-1.1	0.2
2/28/2023 20:40			-1.4	0.4
2/28/2023 20:50			0.1	0.3
2/28/2023 21:00			-1.4	0.7
2/28/2023 21:10			-0.7	0.3
2/28/2023 21:20			-0.8	-0.5
2/28/2023 21:30			-0.2	0.1
2/28/2023 21:40			-1.3	0.2
2/28/2023 21:50			-1.9	-0.3
2/28/2023 22:00			1.7	0.1
2/28/2023 22:10			-1.8	0.4
2/28/2023 22:20			0.4	0.4
2/28/2023 22:30			-3	0.7
2/28/2023 22:40			-1.1	0.3
2/28/2023 22:50			-2.1	0.6
2/28/2023 23:00			1.2	0.3
2/28/2023 23:10			-0.4	1
2/28/2023 23:20			0.9	0.8
2/28/2023 23:30			-2.1	1.1
2/28/2023 23:40			-2.9	1.9
2/28/2023 23:50			-1	0.3

Site Time	Velocity A		Velocity B	
	Vel.x ft/s	Vel.y ft/s	Vel.x ft/s	Vel.y ft/s
America/Chicago				

Site Time	Velocity A		Velocity B	
	Vel.x ft/s	Vel.y ft/s	Vel.x ft/s	Vel.y ft/s
America/Chicago				

































Table with columns: Site, Time, Velocity A (Vel.x, Vel.y), Velocity B (Vel.x, Vel.y). Data from 3/24/2023 3:40 to 3/24/2023 12:10.

Table with columns: Site, Time, Velocity A (Vel.x, Vel.y), Velocity B (Vel.x, Vel.y). Data from 3/24/2023 12:20 to 3/24/2023 20:50.

Table with columns: Site, Time, Velocity A (Vel.x, Vel.y), Velocity B (Vel.x, Vel.y). Data from 3/24/2023 21:00 to 3/25/2023 5:30.

Table with columns: Site, Time, Velocity A (Vel.x, Vel.y), Velocity B (Vel.x, Vel.y). Data from 3/25/2023 5:40 to 3/25/2023 14:10.































































































































Table with 5 columns: Site, Time, Velocity A (Vel.x, Vel.y), Velocity B (Vel.x, Vel.y). Rows range from 6/22/2023 16:00 to 6/23/2023 0:30.

Table with 5 columns: Site, Time, Velocity A (Vel.x, Vel.y), Velocity B (Vel.x, Vel.y). Rows range from 6/23/2023 0:40 to 6/23/2023 9:10.

Table with 5 columns: Site, Time, Velocity A (Vel.x, Vel.y), Velocity B (Vel.x, Vel.y). Rows range from 6/23/2023 9:20 to 6/23/2023 17:50.

Table with 5 columns: Site, Time, Velocity A (Vel.x, Vel.y), Velocity B (Vel.x, Vel.y). Rows range from 6/23/2023 18:00 to 6/24/2023 2:30.





















































Site Time	Velocity A		Velocity B	
	Vel.x ft/s	Vel.y ft/s	Vel.x ft/s	Vel.y ft/s
America/Chicago 7/31/2023 8:00			-0.3	0.5
7/31/2023 8:10			-0.2	0.6
7/31/2023 8:20			-0.2	0.4
7/31/2023 8:30			-0.3	0.2
7/31/2023 8:40			-0.1	0.3
7/31/2023 8:50			-0.4	0.4
7/31/2023 9:00			0	0.3
7/31/2023 9:10			-0.2	0.2
7/31/2023 9:20			0.1	0.4
7/31/2023 9:30			0	0.5
7/31/2023 9:40			-0.2	-0.2
7/31/2023 9:50			0	0
7/31/2023 10:00			-0.1	0.1
7/31/2023 10:10			0	-0.2
7/31/2023 10:20			0.1	0
7/31/2023 10:30			0	-0.1
7/31/2023 10:40			0.1	0
7/31/2023 10:50			-0.1	0
7/31/2023 11:00			0.1	0
7/31/2023 11:10			0	0
7/31/2023 11:20			-0.1	0
7/31/2023 11:30			0	0.1
7/31/2023 11:40			0.2	-0.1
7/31/2023 11:50			0.4	0.2
7/31/2023 12:00			0	0
7/31/2023 12:10			0.1	-0.1
7/31/2023 12:20			0	-0.1
7/31/2023 12:30			0.2	-0.3
7/31/2023 12:40			-0.1	-0.2
7/31/2023 12:50			-0.2	0
7/31/2023 13:00			0	-0.1
7/31/2023 13:10			0.2	-0.1
7/31/2023 13:20			-0.1	-0.1
7/31/2023 13:30			0.1	-0.4
7/31/2023 13:40			0.1	-0.1
7/31/2023 13:50			0.5	-0.3
7/31/2023 14:00			0.2	0.1
7/31/2023 14:10			-0.2	-0.1
7/31/2023 14:20			0.2	-0.3
7/31/2023 14:30			0.2	-0.6
7/31/2023 14:40			0.2	-0.2
7/31/2023 14:50			-0.1	0
7/31/2023 15:00			0.3	-0.5
7/31/2023 15:10			0	-0.1
7/31/2023 15:20			0.2	-0.1
7/31/2023 15:30			0	0.1
7/31/2023 15:40			0.4	-0.1
7/31/2023 15:50			-0.2	0.1
7/31/2023 16:00			0.2	-0.4
7/31/2023 16:10			0.3	-0.5
7/31/2023 16:20			-0.3	0.1
7/31/2023 16:30			0.2	-0.2

Site Time	Velocity A		Velocity B	
	Vel.x ft/s	Vel.y ft/s	Vel.x ft/s	Vel.y ft/s
America/Chicago 7/31/2023 16:40			0.5	-0.2
7/31/2023 16:50			0	-0.2
7/31/2023 17:00			0.6	-0.7
7/31/2023 17:10			0.1	-0.2
7/31/2023 17:20			-0.1	0.1
7/31/2023 17:30			0	-0.1
7/31/2023 17:40			0.2	-0.8
7/31/2023 17:50			0.2	-0.3
7/31/2023 18:00			0	-0.1
7/31/2023 18:10			0.1	-0.1
7/31/2023 18:20			0.3	-0.3
7/31/2023 18:30			0.3	0
7/31/2023 18:40			0.2	-0.1
7/31/2023 18:50			0.2	0
7/31/2023 19:00			0.2	-0.1
7/31/2023 19:10			0.1	-0.2
7/31/2023 19:20			0.2	0
7/31/2023 19:30			0.1	-0.1
7/31/2023 19:40			0	-0.1
7/31/2023 19:50			0.2	0
7/31/2023 20:00			0.2	-0.1
7/31/2023 20:10			-0.1	0
7/31/2023 20:20			0.2	-0.1
7/31/2023 20:30			0.1	-0.2
7/31/2023 20:40			-0.1	0
7/31/2023 20:50			0	-0.1
7/31/2023 21:00			0	0.1
7/31/2023 21:10			0	-0.1
7/31/2023 21:20			-0.1	0
7/31/2023 21:30			-0.1	0
7/31/2023 21:40			0	-0.1
7/31/2023 21:50			-0.1	0
7/31/2023 22:00			0.1	-0.2
7/31/2023 22:10			-0.1	-0.1
7/31/2023 22:20			0.1	-0.3
7/31/2023 22:30			0	-0.2
7/31/2023 22:40			0	-0.1
7/31/2023 22:50			-0.1	0
7/31/2023 23:00			0	0
7/31/2023 23:10			0	0.1
7/31/2023 23:20			0	0
7/31/2023 23:30			0.2	0.2
7/31/2023 23:40			0.2	0
7/31/2023 23:50			0.1	0.1

Site Time	Velocity A		Velocity B	
	Vel.x ft/s	Vel.y ft/s	Vel.x ft/s	Vel.y ft/s
America/Chicago				

Site Time	Velocity A		Velocity B	
	Vel.x ft/s	Vel.y ft/s	Vel.x ft/s	Vel.y ft/s
America/Chicago				























Site	Velocity A		Velocity B		Site	Velocity A		Velocity B		Site	Velocity A		Velocity B		Site	Velocity A		Velocity B	
Time	Vel.x	Vel.y	Vel.x	Vel.y	Time	Vel.x	Vel.y	Vel.x	Vel.y	Time	Vel.x	Vel.y	Vel.x	Vel.y	Time	Vel.x	Vel.y	Vel.x	Vel.y
America/Chicago	ft/s	ft/s	ft/s	ft/s	America/Chicago	ft/s	ft/s	ft/s	ft/s	America/Chicago	ft/s	ft/s	ft/s	ft/s	America/Chicago	ft/s	ft/s	ft/s	ft/s
8/16/2023 21:20			0.2	-0.2	8/17/2023 6:00			-0.2	0	8/17/2023 14:40			0.2	0	8/17/2023 23:20			-0.2	0
8/16/2023 21:30			0.1	-0.1	8/17/2023 6:10			-0.2	0	8/17/2023 14:50			0.1	-0.3	8/17/2023 23:30			0	-0.2
8/16/2023 21:40			0	0.1	8/17/2023 6:20			-0.2	0.2	8/17/2023 15:00			0.2	-0.3	8/17/2023 23:40			0.1	-0.1
8/16/2023 21:50			0	0.2	8/17/2023 6:30			-0.2	0	8/17/2023 15:10			0	0.2	8/17/2023 23:50			0	0
8/16/2023 22:00			-0.1	0	8/17/2023 6:40			-0.1	0.1	8/17/2023 15:20			0	0.3	8/18/2023 0:00			0	0
8/16/2023 22:10			-0.1	0.1	8/17/2023 6:50			-0.3	-0.1	8/17/2023 15:30			-0.2	0.2	8/18/2023 0:10			0	0.1
8/16/2023 22:20			0	0.1	8/17/2023 7:00			-0.2	0.1	8/17/2023 15:40			-0.2	0.1	8/18/2023 0:20			-0.2	0.1
8/16/2023 22:30			0.1	0	8/17/2023 7:10			-0.1	0.2	8/17/2023 15:50			0	0	8/18/2023 0:30			0	0.1
8/16/2023 22:40			0.1	0	8/17/2023 7:20			-0.1	0	8/17/2023 16:00			0.1	0.2	8/18/2023 0:40			0	0
8/16/2023 22:50			0.1	0.1	8/17/2023 7:30			0	-0.1	8/17/2023 16:10			0.5	-0.2	8/18/2023 0:50			-0.2	0
8/16/2023 23:00			-0.1	0.1	8/17/2023 7:40			-0.1	0	8/17/2023 16:20			0.2	-0.1	8/18/2023 1:00			-0.1	0
8/16/2023 23:10			0	0.1	8/17/2023 7:50			0	0.1	8/17/2023 16:30			0.1	-0.2	8/18/2023 1:10			0	-0.1
8/16/2023 23:20			0	-0.1	8/17/2023 8:00			0	-0.1	8/17/2023 16:40			0.2	0	8/18/2023 1:20			-0.1	0
8/16/2023 23:30			0	0	8/17/2023 8:10			-0.1	0.1	8/17/2023 16:50			0	0	8/18/2023 1:30			-0.2	0.1
8/16/2023 23:40			-0.1	0	8/17/2023 8:20			-0.1	0.1	8/17/2023 17:00			-0.2	0	8/18/2023 1:40			0	-0.1
8/16/2023 23:50			0	0	8/17/2023 8:30			-0.2	0.2	8/17/2023 17:10			0	-0.1	8/18/2023 1:50			-0.1	0
8/17/2023 0:00			0	0	8/17/2023 8:40			-0.3	0.4	8/17/2023 17:20			0	-0.1	8/18/2023 2:00			0	-0.1
8/17/2023 0:10			-0.1	-0.1	8/17/2023 8:50			-0.1	0.1	8/17/2023 17:30			0.2	-0.1	8/18/2023 2:10			0	0
8/17/2023 0:20			-0.2	0	8/17/2023 9:00			0	0.1	8/17/2023 17:40			-0.3	0	8/18/2023 2:20			-0.1	0.2
8/17/2023 0:30			0.1	0	8/17/2023 9:10			-0.1	0.1	8/17/2023 17:50			0.2	-0.2	8/18/2023 2:30			0	-0.1
8/17/2023 0:40			0.1	0	8/17/2023 9:20			0	0.1	8/17/2023 18:00			0.1	0	8/18/2023 2:40			0	-0.1
8/17/2023 0:50			-0.1	0	8/17/2023 9:30			-0.2	-0.1	8/17/2023 18:10			0	0	8/18/2023 2:50			0.1	-0.1
8/17/2023 1:00			0	0	8/17/2023 9:40			-0.1	0	8/17/2023 18:20			0.6	-0.3	8/18/2023 3:00			-0.2	-0.1
8/17/2023 1:10			0	0	8/17/2023 9:50			-0.1	0.2	8/17/2023 18:30			0.2	-0.1	8/18/2023 3:10			0.1	0
8/17/2023 1:20			-0.1	0.1	8/17/2023 10:00			0.2	-0.1	8/17/2023 18:40			0.1	-0.1	8/18/2023 3:20			0	0
8/17/2023 1:30			0	0	8/17/2023 10:10			0	0	8/17/2023 18:50			0.4	-0.3	8/18/2023 3:30			-0.1	0
8/17/2023 1:40			0.1	0.1	8/17/2023 10:20			0	-0.2	8/17/2023 19:00			0	-0.2	8/18/2023 3:40			-0.1	0
8/17/2023 1:50			0.1	0.2	8/17/2023 10:30			0	0	8/17/2023 19:10			0.2	-0.4	8/18/2023 3:50			0	-0.1
8/17/2023 2:00			0.1	0.1	8/17/2023 10:40			-0.4	0	8/17/2023 19:20			0.1	-0.4	8/18/2023 4:00			0	0.1
8/17/2023 2:10			0.1	0	8/17/2023 10:50			-0.6	-0.8	8/17/2023 19:30			0.1	-0.1	8/18/2023 4:10			0.1	0.2
8/17/2023 2:20			0.1	0	8/17/2023 11:00			0.1	0.1	8/17/2023 19:40			0	0	8/18/2023 4:20			0.1	-0.1
8/17/2023 2:30			0.2	0	8/17/2023 11:10			0.1	-0.1	8/17/2023 19:50			0	0	8/18/2023 4:30			0.1	-0.1
8/17/2023 2:40			0.1	0	8/17/2023 11:20			0.1	-0.3	8/17/2023 20:00			0.2	-0.1	8/18/2023 4:40			0	-0.1
8/17/2023 2:50			0.1	0.1	8/17/2023 11:30			-0.2	0.1	8/17/2023 20:10			0.1	-0.1	8/18/2023 4:50			0.2	-0.1
8/17/2023 3:00			0.2	0	8/17/2023 11:40			0.1	0.3	8/17/2023 20:20			0.1	-0.3	8/18/2023 5:00			0.3	-0.1
8/17/2023 3:10			0.2	-0.1	8/17/2023 11:50			0	-0.2	8/17/2023 20:30			0	0	8/18/2023 5:10			0.1	-0.1
8/17/2023 3:20			0.2	0	8/17/2023 12:00			0	0	8/17/2023 20:40			0.4	0	8/18/2023 5:20			0.3	0.1
8/17/2023 3:30			0.2	0	8/17/2023 12:10			0	0.1	8/17/2023 20:50			0.5	-0.1	8/18/2023 5:30			-0.1	0.1
8/17/2023 3:40			0.1	0	8/17/2023 12:20			0	-0.1	8/17/2023 21:00			0.2	0.1	8/18/2023 5:40			-0.2	0.2
8/17/2023 3:50			0	0	8/17/2023 12:30			0.1	-0.3	8/17/2023 21:10			0.5	0	8/18/2023 5:50			-0.2	0.4
8/17/2023 4:00			0	0	8/17/2023 12:40			0.2	-0.5	8/17/2023 21:20			0.7	-0.1	8/18/2023 6:00			0	1
8/17/2023 4:10			0	0	8/17/2023 12:50			0	-0.1	8/17/2023 21:30			0.2	0	8/18/2023 6:10			-0.4	-0.1
8/17/2023 4:20			0	0.1	8/17/2023 13:00			-0.2	0.1	8/17/2023 21:40			0.8	-0.1	8/18/2023 6:20			-0.3	0.1
8/17/2023 4:30			0.1	0	8/17/2023 13:10			-0.1	0	8/17/2023 21:50			0.1	0	8/18/2023 6:30			-0.3	0.1
8/17/2023 4:40			0	0	8/17/2023 13:20			0	-0.2	8/17/2023 22:00			0.5	-0.2	8/18/2023 6:40			-0.1	-0.2
8/17/2023 4:50			0	0	8/17/2023 13:30			0.3	-0.3	8/17/2023 22:10			0.3	-0.3	8/18/2023 6:50			-0.1	0.2
8/17/2023 5:00			0	0.1	8/17/2023 13:40			0	-0.1	8/17/2023 22:20			0.1	-0.3	8/18/2023 7:00			-0.1	-0.1
8/17/2023 5:10			0	0.1	8/17/2023 13:50			0.2	-0.2	8/17/2023 22:30			0	-0.1	8/18/2023 7:10			-0.2	0.1
8/17/2023 5:20			0.1	0.6	8/17/2023 14:00			0	-0.3	8/17/2023 22:40			0.2	-0.4	8/18/2023 7:20			-0.1	0.1
8/17/2023 5:30			0	0.5	8/17/2023 14:10			0.2	-0.3	8/17/2023 22:50			0.2	-0.2	8/18/2023 7:30			-0.1	0.1
8/17/2023 5:40			-0.4	0.1	8/17/2023 14:20			0.3	-0.3	8/17/2023 23:00			0.1	-0.1	8/18/2023 7:40			-0.1	-0.1
8/17/2023 5:50			-0.2	0.1	8/17/2023 14:30			-0.3	0	8/17/2023 23:10			0	0	8/18/2023 7:50			-0.3	0.1







































































Table with columns: Site, Time, Velocity A (Vel.x, Vel.y), Velocity B (Vel.x, Vel.y). Data rows range from 10/6/2023 18:40 to 10/7/2023 3:10.

Table with columns: Site, Time, Velocity A (Vel.x, Vel.y), Velocity B (Vel.x, Vel.y). Data rows range from 10/7/2023 3:20 to 10/7/2023 11:50.

Table with columns: Site, Time, Velocity A (Vel.x, Vel.y), Velocity B (Vel.x, Vel.y). Data rows range from 10/7/2023 12:00 to 10/7/2023 20:30.

Table with columns: Site, Time, Velocity A (Vel.x, Vel.y), Velocity B (Vel.x, Vel.y). Data rows range from 10/7/2023 20:40 to 10/8/2023 5:10.



















































Site Time	Velocity A		Velocity B	
	Vel.x ft/s	Vel.y ft/s	Vel.x ft/s	Vel.y ft/s
America/Chicago				
11/12/2023 12:20			-0.1	0
11/12/2023 12:30			-0.1	0
11/12/2023 12:40			0	-0.1
11/12/2023 12:50			0	0
11/12/2023 13:00			0	0
11/12/2023 13:10			-0.1	0
11/12/2023 13:20			0	0
11/12/2023 13:30			0	-0.1
11/12/2023 13:40			0	0
11/12/2023 13:50			0	0
11/12/2023 14:00			0	-0.1
11/12/2023 14:10			0	0
11/12/2023 14:20			0	0.1
11/12/2023 14:30			0	0
11/12/2023 14:40			0	0
11/12/2023 14:50			0	0
11/12/2023 15:00			0	0
11/12/2023 15:10			0.1	0
11/12/2023 15:20			0	-0.1
11/12/2023 15:30			0.1	0
11/12/2023 15:40			0	0
11/12/2023 15:50			0.1	0
11/12/2023 16:00			0.1	0
11/12/2023 16:10			0	-0.1
11/12/2023 16:20			-0.1	0.1
11/12/2023 16:30			0.1	0.1
11/12/2023 16:40			-0.1	0.2
11/12/2023 16:50			0	0
11/12/2023 17:00			-0.3	0.1
11/12/2023 17:10			0	0.2
11/12/2023 17:20			-0.1	0
11/12/2023 17:30			0	0.1
11/12/2023 17:40			0.2	0.3
11/12/2023 17:50			0.1	0.2
11/12/2023 18:00			-0.1	0
11/12/2023 18:10			0.3	0.4
11/12/2023 18:20			0	0.2
11/12/2023 18:30			-0.1	0.1
11/12/2023 18:40			0.1	0.4
11/12/2023 18:50			-0.1	0.3
11/12/2023 19:00			-0.1	0.2
11/12/2023 19:10			-0.2	0
11/12/2023 19:20			-0.2	0.1
11/12/2023 19:30			-0.1	0
11/12/2023 19:40			-0.2	0
11/12/2023 19:50			-0.1	0
11/12/2023 20:00			-0.1	0
11/12/2023 20:10			0.2	0.1
11/12/2023 20:20			-0.1	0
11/12/2023 20:30			-0.1	-0.1
11/12/2023 20:40			-0.1	0.1
11/12/2023 20:50			-0.1	-0.1
11/12/2023 21:00			0	-0.1
11/12/2023 21:10			-0.3	-0.1
11/12/2023 21:20			-0.1	0
11/12/2023 21:30			-0.1	0
11/12/2023 21:40			-0.1	0
11/12/2023 21:50			-0.1	0.1
11/12/2023 22:00			0	0.1
11/12/2023 22:10			-0.2	-0.1
11/12/2023 22:20			-0.1	0
11/12/2023 22:30			-0.1	0
11/12/2023 22:40			0	0
11/12/2023 22:50			-0.1	0
11/12/2023 23:00			-0.1	-0.1
11/12/2023 23:10			0.1	0
11/12/2023 23:20			-0.1	-0.2
11/12/2023 23:30			0	0
11/12/2023 23:40			-0.2	-0.1
11/12/2023 23:50			0	-0.1
11/13/2023 0:00			0	-0.2
11/13/2023 0:10			-0.1	0
11/13/2023 0:20			0	-0.1
11/13/2023 0:30			-0.1	-0.1
11/13/2023 0:40			0	-0.1
11/13/2023 0:50			0	-0.1
11/13/2023 1:00			0	-0.1
11/13/2023 1:10			0	-0.1
11/13/2023 1:20			-0.1	-0.1
11/13/2023 1:30			0	0
11/13/2023 1:40			-0.1	0
11/13/2023 1:50			0	-0.1
11/13/2023 2:00			-0.1	0
11/13/2023 2:10			0	0
11/13/2023 2:20			0	-0.1
11/13/2023 2:30			-0.1	-0.1
11/13/2023 2:40			-0.1	-0.2
11/13/2023 2:50			0	-0.1
11/13/2023 3:00			0	0
11/13/2023 3:10			-0.1	-0.1
11/13/2023 3:20			-0.1	-0.2
11/13/2023 3:30			-0.1	-0.1
11/13/2023 3:40			-0.1	-0.2
11/13/2023 3:50			0.1	-0.3
11/13/2023 4:00			-0.1	-0.2
11/13/2023 4:10			0	0
11/13/2023 4:20			0.1	0
11/13/2023 4:30			-0.1	0
11/13/2023 4:40			-0.1	0
11/13/2023 4:50			0	-0.2
11/13/2023 5:00			0	-0.1
11/13/2023 5:10			-0.1	-0.1
11/13/2023 5:20			0	-0.1
11/13/2023 5:30			0	0
11/13/2023 5:40			0	0
11/13/2023 5:50			-0.1	0
11/13/2023 6:00			-0.1	-0.1
11/13/2023 6:10			0	-0.2
11/13/2023 6:20			-0.1	-0.1
11/13/2023 6:30			0	0.1
11/13/2023 6:40			-0.1	-0.1
11/13/2023 6:50			-0.1	-0.1
11/13/2023 7:00			0	-0.1
11/13/2023 7:10			-0.1	0
11/13/2023 7:20			0.1	0
11/13/2023 7:30			0	0
11/13/2023 7:40			0.1	-0.1
11/13/2023 7:50			0	-0.1
11/13/2023 8:00			0	0
11/13/2023 8:10			0	0
11/13/2023 8:20			-0.2	-0.1
11/13/2023 8:30			-0.2	-0.1
11/13/2023 8:40			-0.1	-0.1
11/13/2023 8:50			0	0
11/13/2023 9:00			0	0
11/13/2023 9:10			0	0
11/13/2023 9:20			-0.1	-0.1
11/13/2023 9:30			-0.1	0
11/13/2023 9:40			0	0
11/13/2023 9:50			0	0
11/13/2023 10:00			-0.1	0
11/13/2023 10:10			-0.1	0
11/13/2023 10:20			0	-0.1
11/13/2023 10:30			-0.1	-0.1
11/13/2023 10:40			0	0
11/13/2023 10:50			0.1	0
11/13/2023 11:00			0	0
11/13/2023 11:10			0.1	0
11/13/2023 11:20			-0.2	0.1
11/13/2023 11:30			0	0
11/13/2023 11:40			0	-0.2
11/13/2023 11:50			0	-0.1
11/13/2023 12:00			0	0.1
11/13/2023 12:10			-0.1	-0.1
11/13/2023 12:20			0	0
11/13/2023 12:30			-0.1	0
11/13/2023 12:40			0	0
11/13/2023 12:50			0	0
11/13/2023 13:00			0	-0.1
11/13/2023 13:10			0	-0.2
11/13/2023 13:20			0	-0.1
11/13/2023 13:30			0	0
11/13/2023 13:40			0	-0.1
11/13/2023 13:50			0	0
11/13/2023 14:00			0	0
11/13/2023 14:10			0	0























Site Time	Velocity A		Velocity B	
	Vel.x ft/s	Vel.y ft/s	Vel.x ft/s	Vel.y ft/s
America/Chicago				
11/29/2023 20:20			-0.5	-0.1
11/29/2023 20:30			0.3	0.4
11/29/2023 20:40			-0.2	-0.2
11/29/2023 20:50			0.6	1.2
11/29/2023 21:00			0.8	2.6
11/29/2023 21:10			-0.3	-1
11/29/2023 21:20			0.1	0.1
11/29/2023 21:30			0.1	0.3
11/29/2023 21:40			0.1	2.2
11/29/2023 21:50			-0.1	-0.6
11/29/2023 22:00			-0.7	-0.8
11/29/2023 22:10			-0.9	-1
11/29/2023 22:20			0	1
11/29/2023 22:30			0.3	0.9
11/29/2023 22:40			0.1	0.6
11/29/2023 22:50			0.7	-1.1
11/29/2023 23:00			-0.1	0.1
11/29/2023 23:10			-1.4	1.7
11/29/2023 23:20			-2.1	0.8
11/29/2023 23:30			-0.5	0
11/29/2023 23:40			-0.9	0.4
11/29/2023 23:50			1.3	0.4
11/30/2023 0:00			1	1.1
11/30/2023 0:10			0.7	0.7
11/30/2023 0:20			0.1	-0.2
11/30/2023 0:30			1.5	0.5
11/30/2023 0:40			0.7	1.5
11/30/2023 0:50			-0.4	-0.5
11/30/2023 1:00			0.8	0.6
11/30/2023 1:10			0.9	0.1
11/30/2023 1:20			0.4	0.5
11/30/2023 1:30			0.4	0.5
11/30/2023 1:40			0.3	1
11/30/2023 1:50			0.3	0.9
11/30/2023 2:00			0.9	0.8
11/30/2023 2:10			0.9	0.2
11/30/2023 2:20			0.8	0.8
11/30/2023 2:30			0	0.4
11/30/2023 2:40			0.9	1.1
11/30/2023 2:50			1.5	1.2
11/30/2023 3:00			0.8	0.9
11/30/2023 3:10			1.1	0.4
11/30/2023 3:20			1.6	0.1
11/30/2023 3:30			-0.4	0.4
11/30/2023 3:40			2.2	-0.2
11/30/2023 3:50			1	0
11/30/2023 4:00			0.2	-0.4
11/30/2023 4:10			0.9	0.1
11/30/2023 4:20			-0.2	-0.3
11/30/2023 4:30			1.6	0.9
11/30/2023 4:40			2.3	0.7
11/30/2023 4:50			0.6	0

Site Time	Velocity A		Velocity B	
	Vel.x ft/s	Vel.y ft/s	Vel.x ft/s	Vel.y ft/s
America/Chicago				
11/30/2023 5:00			1.6	0.8
11/30/2023 5:10			1.6	1.1
11/30/2023 5:20			2.1	0.8
11/30/2023 5:30			1	0.3
11/30/2023 5:40			0.3	-0.1
11/30/2023 5:50			0	0.1
11/30/2023 6:00			1.2	0.4
11/30/2023 6:10			2.5	0.2
11/30/2023 6:20			0.1	0.3
11/30/2023 6:30			1.8	0.3
11/30/2023 6:40			-0.5	-0.4
11/30/2023 6:50			0.4	0
11/30/2023 7:00			0.5	0
11/30/2023 7:10			0.9	0.3
11/30/2023 7:20			1.2	0.6
11/30/2023 7:30			-0.2	-0.2
11/30/2023 7:40			0.2	0.8
11/30/2023 7:50			-0.8	0.3
11/30/2023 8:00			-0.3	-0.2
11/30/2023 8:10			1.4	0.7
11/30/2023 8:20			0.1	1.6
11/30/2023 8:30			0.4	0.9
11/30/2023 8:40			0.2	0.6
11/30/2023 8:50			0.9	-0.5
11/30/2023 9:00			0	-0.6
11/30/2023 9:10			0.5	0.2
11/30/2023 9:20			-0.1	-0.1
11/30/2023 9:30			0.3	0.3
11/30/2023 9:40			-1.3	-1.4
11/30/2023 9:50			0.4	0.3
11/30/2023 10:00			-0.4	-0.4
11/30/2023 10:10			-0.3	-0.4
11/30/2023 10:20			-1.7	-1.2
11/30/2023 10:30			-0.2	-0.1
11/30/2023 10:40			0.3	0.2
11/30/2023 10:50			-0.5	-0.1
11/30/2023 11:00			0.2	0.1
11/30/2023 11:10			-0.7	-0.4
11/30/2023 11:20			-0.5	-0.7
11/30/2023 11:30			-0.2	-0.2
11/30/2023 11:40			-0.7	-1.1
11/30/2023 11:50			-0.1	-0.4
11/30/2023 12:00			0.2	0.1
11/30/2023 12:10			-0.8	-0.6
11/30/2023 12:20			-0.1	-0.3
11/30/2023 12:30			-1.3	-1.5
11/30/2023 12:40			-0.4	-1
11/30/2023 12:50			-0.5	-0.8
11/30/2023 13:00			-0.1	-0.6
11/30/2023 13:10			-0.1	-0.4
11/30/2023 13:20			0.7	-1.5
11/30/2023 13:30			0.7	-1.1

Site Time	Velocity A		Velocity B	
	Vel.x ft/s	Vel.y ft/s	Vel.x ft/s	Vel.y ft/s
America/Chicago				
11/30/2023 13:40			1.1	-2.9
11/30/2023 13:50			0.4	-1
11/30/2023 14:00			1.1	-2.2
11/30/2023 14:10			0.5	-0.2
11/30/2023 14:20			0.3	0.3
11/30/2023 14:30			1.4	-2.5
11/30/2023 14:40			0.5	0.3
11/30/2023 14:50			0.4	0.1
11/30/2023 15:00			0.9	0.4
11/30/2023 15:10			-0.1	0.2
11/30/2023 15:20			-0.8	-0.1
11/30/2023 15:30			-0.1	0.1
11/30/2023 15:40			0.3	0
11/30/2023 15:50			-0.2	-1.1
11/30/2023 16:00			-0.2	-0.4
11/30/2023 16:10			-0.1	-0.2
11/30/2023 16:20			0	-0.6
11/30/2023 16:30			0.1	-0.4
11/30/2023 16:40			-0.2	0.1
11/30/2023 16:50			0.4	0.3
11/30/2023 17:00			-0.5	0.1
11/30/2023 17:10			-1.5	-0.7
11/30/2023 17:20			0.1	0.4
11/30/2023 17:30			0.1	0.3
11/30/2023 17:40			-0.3	-0.5
11/30/2023 17:50			0.1	0
11/30/2023 18:00			0.5	0.4
11/30/2023 18:10			0.3	0.4
11/30/2023 18:20			-0.1	-0.3
11/30/2023 18:30			0.3	0.2
11/30/2023 18:40			-1.1	-0.7
11/30/2023 18:50			-0.3	-0.1
11/30/2023 19:00			-0.1	0
11/30/2023 19:10			0.1	0.2
11/30/2023 19:20			0.7	0.7
11/30/2023 19:30			1.1	0.7
11/30/2023 19:40			-0.2	0.3
11/30/2023 19:50			0.1	0.9
11/30/2023 20:00			1.2	0.8
11/30/2023 20:10			0.6	0.3
11/30/2023 20:20			0.3	0.2
11/30/2023 20:30			1.3	0.9
11/30/2023 20:40			0	0.1
11/30/2023 20:50			0.1	0.4
11/30/2023 21:00			1.8	2.1
11/30/2023 21:10			-1.4	-0.4
11/30/2023 21:20			-1.7	-0.3
11/30/2023 21:30			0.2	0.3
11/30/2023 21:40			-0.1	0.1
11/30/2023 21:50			-0.3	0.3
11/30/2023 22:00			1	1
11/30/2023 22:10			0.7	0.2

Site Time	Velocity A		Velocity B	
	Vel.x ft/s	Vel.y ft/s	Vel.x ft/s	Vel.y ft/s
America/Chicago				
11/30/2023 22:20			0.8	0.5
11/30/2023 22:30			1.2	0.6
11/30/2023 22:40			1	0.1
11/30/2023 22:50			0.7	-0.4
11/30/2023 23:00			-0.1	0.1
11/30/2023 23:10			0.8	1.4
11/30/2023 23:20			0.6	1.4
11/30/2023 23:30			0.3	1.7
11/30/2023 23:40			-0.2	1.1
11/30/2023 23:50			0.5	1.8











































Site Time America/Chicago	Velocity A		Velocity B	
	Vel.x ft/s	Vel.y ft/s	Vel.x ft/s	Vel.y ft/s
12/31/2023 8:00			0	0
12/31/2023 8:10			0.1	0.1
12/31/2023 8:20			0.1	0
12/31/2023 8:30			0.2	-0.1
12/31/2023 8:40			0	-0.1
12/31/2023 8:50			-0.1	-0.1
12/31/2023 9:00			0.2	0.1
12/31/2023 9:10			0.1	0.1
12/31/2023 9:20			0.1	0
12/31/2023 9:30			0.2	0
12/31/2023 9:40			0	-0.1
12/31/2023 9:50				
12/31/2023 10:00				
12/31/2023 10:10				
12/31/2023 10:20				
12/31/2023 10:30			0	0.1
12/31/2023 10:40				
12/31/2023 10:50				
12/31/2023 11:00				
12/31/2023 11:10				
12/31/2023 11:20				
12/31/2023 11:30				
12/31/2023 11:40				
12/31/2023 11:50				
12/31/2023 12:00				
12/31/2023 12:10				
12/31/2023 12:20				
12/31/2023 12:30				
12/31/2023 12:40				
12/31/2023 12:50				
12/31/2023 13:00				
12/31/2023 13:10				
12/31/2023 13:20				
12/31/2023 13:30				
12/31/2023 13:40			0.2	0
12/31/2023 13:50			0.2	0.1
12/31/2023 14:00			0	0.2
12/31/2023 14:10			-0.1	-6.7
12/31/2023 14:20			-0.3	0
12/31/2023 14:30				
12/31/2023 14:40				
12/31/2023 14:50			-0.2	-3.2
12/31/2023 15:00			-0.4	0.1
12/31/2023 15:10			0.6	0.3
12/31/2023 15:20			0.4	0.1
12/31/2023 15:30			0.4	0.2
12/31/2023 15:40			0.4	0.2
12/31/2023 15:50			0.6	0.6
12/31/2023 16:00			0.4	-0.2
12/31/2023 16:10			0.4	0.2
12/31/2023 16:20			0.2	-0.2
12/31/2023 16:30			0.4	0.8

Site Time America/Chicago	Velocity A		Velocity B	
	Vel.x ft/s	Vel.y ft/s	Vel.x ft/s	Vel.y ft/s
12/31/2023 16:40			0.4	0.2
12/31/2023 16:50			0	0
12/31/2023 17:00			0.2	-0.2
12/31/2023 17:10			0	-0.1
12/31/2023 17:20			0.1	0.1
12/31/2023 17:30			0.1	-0.2
12/31/2023 17:40			-0.1	-0.1
12/31/2023 17:50			-0.2	0.3
12/31/2023 18:00			0.2	-0.2
12/31/2023 18:10			0.2	-0.2
12/31/2023 18:20			0.3	-0.1
12/31/2023 18:30			0.1	0.2
12/31/2023 18:40				
12/31/2023 18:50			0.4	-0.1
12/31/2023 19:00			0.1	-0.4
12/31/2023 19:10			0	0
12/31/2023 19:20			0.7	0
12/31/2023 19:30			0.3	-0.1
12/31/2023 19:40				
12/31/2023 19:50				
12/31/2023 20:00			0	0
12/31/2023 20:10			0.4	0
12/31/2023 20:20			0.3	-0.1
12/31/2023 20:30			0.4	-0.1
12/31/2023 20:40				
12/31/2023 20:50			-0.1	0
12/31/2023 21:00			0.5	0.2
12/31/2023 21:10			0.2	-0.1
12/31/2023 21:20			0	-0.2
12/31/2023 21:30			0.1	0
12/31/2023 21:40				
12/31/2023 21:50				
12/31/2023 22:00			0.1	-0.1
12/31/2023 22:10				
12/31/2023 22:20				
12/31/2023 22:30			0	-0.2
12/31/2023 22:40				
12/31/2023 22:50				
12/31/2023 23:00				
12/31/2023 23:10				
12/31/2023 23:20			0.1	0.2
12/31/2023 23:30				
12/31/2023 23:40				
12/31/2023 23:50				

Site Time America/Chicago	Velocity A		Velocity B	
	Vel.x ft/s	Vel.y ft/s	Vel.x ft/s	Vel.y ft/s

Site Time America/Chicago	Velocity A		Velocity B	
	Vel.x ft/s	Vel.y ft/s	Vel.x ft/s	Vel.y ft/s















Site Time	Velocity A		Velocity B	
	Vel.x ft/s	Vel.y ft/s	Vel.x ft/s	Vel.y ft/s
America/Chicago				
1/11/2024 2:40				
1/11/2024 2:50				
1/11/2024 3:00				
1/11/2024 3:10				
1/11/2024 3:20				
1/11/2024 3:30				
1/11/2024 3:40				
1/11/2024 3:50				
1/11/2024 4:00				
1/11/2024 4:10				
1/11/2024 4:20				
1/11/2024 4:30				
1/11/2024 4:40				
1/11/2024 4:50				
1/11/2024 5:00				
1/11/2024 5:10				
1/11/2024 5:20				
1/11/2024 5:30				
1/11/2024 5:40				
1/11/2024 5:50				
1/11/2024 6:00				
1/11/2024 6:10				
1/11/2024 6:20				
1/11/2024 6:30				
1/11/2024 6:40				
1/11/2024 6:50				
1/11/2024 7:00				
1/11/2024 7:10				
1/11/2024 7:20				
1/11/2024 7:30				
1/11/2024 7:40				
1/11/2024 7:50				
1/11/2024 8:00				
1/11/2024 8:10				
1/11/2024 8:20				
1/11/2024 8:30				
1/11/2024 8:40				
1/11/2024 8:50				
1/11/2024 9:00				
1/11/2024 9:10				
1/11/2024 9:20				
1/11/2024 9:30				
1/11/2024 9:40				
1/11/2024 9:50				
1/11/2024 10:00				
1/11/2024 10:10				
1/11/2024 10:20				
1/11/2024 10:30				
1/11/2024 10:40				
1/11/2024 10:50				
1/11/2024 11:00				
1/11/2024 11:10				

Site Time	Velocity A		Velocity B	
	Vel.x ft/s	Vel.y ft/s	Vel.x ft/s	Vel.y ft/s
America/Chicago				
1/11/2024 11:20				
1/11/2024 11:30				
1/11/2024 11:40				
1/11/2024 11:50				
1/11/2024 12:00				
1/11/2024 12:10				
1/11/2024 12:20				
1/11/2024 12:30				
1/11/2024 12:40				
1/11/2024 12:50				
1/11/2024 13:00				
1/11/2024 13:10				
1/11/2024 13:20				
1/11/2024 13:30				
1/11/2024 13:40				
1/11/2024 13:50				
1/11/2024 14:00				
1/11/2024 14:10				
1/11/2024 14:20				
1/11/2024 14:30				
1/11/2024 14:40				
1/11/2024 14:50				
1/11/2024 15:00				
1/11/2024 15:10				
1/11/2024 15:20				
1/11/2024 15:30				
1/11/2024 15:40				
1/11/2024 15:50				
1/11/2024 16:00				
1/11/2024 16:10				
1/11/2024 16:20				
1/11/2024 16:30				
1/11/2024 16:40				
1/11/2024 16:50				
1/11/2024 17:00				
1/11/2024 17:10				
1/11/2024 17:20				
1/11/2024 17:30				
1/11/2024 17:40				
1/11/2024 17:50				
1/11/2024 18:00				
1/11/2024 18:10				
1/11/2024 18:20				
1/11/2024 18:30				
1/11/2024 18:40				
1/11/2024 18:50				
1/11/2024 19:00				
1/11/2024 19:10				
1/11/2024 19:20				
1/11/2024 19:30				
1/11/2024 19:40				
1/11/2024 19:50				

Site Time	Velocity A		Velocity B	
	Vel.x ft/s	Vel.y ft/s	Vel.x ft/s	Vel.y ft/s
America/Chicago				
1/11/2024 20:00				
1/11/2024 20:10				
1/11/2024 20:20				
1/11/2024 20:30				
1/11/2024 20:40				
1/11/2024 20:50				
1/11/2024 21:00				
1/11/2024 21:10				
1/11/2024 21:20				
1/11/2024 21:30				
1/11/2024 21:40				
1/11/2024 21:50				
1/11/2024 22:00				
1/11/2024 22:10				
1/11/2024 22:20				
1/11/2024 22:30				
1/11/2024 22:40				
1/11/2024 22:50				
1/11/2024 23:00				
1/11/2024 23:10				
1/11/2024 23:20				
1/11/2024 23:30				
1/11/2024 23:40				
1/11/2024 23:50				
1/12/2024 0:00				
1/12/2024 0:10				
1/12/2024 0:20				
1/12/2024 0:30				
1/12/2024 0:40				
1/12/2024 0:50				
1/12/2024 1:00				
1/12/2024 1:10				
1/12/2024 1:20				
1/12/2024 1:30				
1/12/2024 1:40				
1/12/2024 1:50				
1/12/2024 2:00				
1/12/2024 2:10				
1/12/2024 2:20				
1/12/2024 2:30				
1/12/2024 2:40				
1/12/2024 2:50				
1/12/2024 3:00				
1/12/2024 3:10				
1/12/2024 3:20				
1/12/2024 3:30				
1/12/2024 3:40				
1/12/2024 3:50				
1/12/2024 4:00				
1/12/2024 4:10				
1/12/2024 4:20				
1/12/2024 4:30				

Site Time	Velocity A		Velocity B	
	Vel.x ft/s	Vel.y ft/s	Vel.x ft/s	Vel.y ft/s
America/Chicago				
1/12/2024 4:40				
1/12/2024 4:50				
1/12/2024 5:00				
1/12/2024 5:10				
1/12/2024 5:20				
1/12/2024 5:30				
1/12/2024 5:40				
1/12/2024 5:50				
1/12/2024 6:00				
1/12/2024 6:10				
1/12/2024 6:20				
1/12/2024 6:30				
1/12/2024 6:40				
1/12/2024 6:50				
1/12/2024 7:00				
1/12/2024 7:10				
1/12/2024 7:20				
1/12/2024 7:30				
1/12/2024 7:40				
1/12/2024 7:50				
1/12/2024 8:00				
1/12/2024 8:10				
1/12/2024 8:20				
1/12/2024 8:30				
1/12/2024 8:40				
1/12/2024 8:50				
1/12/2024 9:00				
1/12/2024 9:10				
1/12/2024 9:20				
1/12/2024 9:30				
1/12/2024 9:40				
1/12/2024 9:50				
1/12/2024 10:00				
1/12/2024 10:10				
1/12/2024 10:20				
1/12/2024 10:30				
1/12/2024 10:40				
1/12/2024 10:50				
1/12/2024 11:00				
1/12/2024 11:10				
1/12/2024 11:20				
1/12/2024 11:30				
1/12/2024 11:40				
1/12/2024 11:50				
1/12/2024 12:00				
1/12/2024 12:10				
1/12/2024 12:20				
1/12/2024 12:30				
1/12/2024 12:40				
1/12/2024 12:50				
1/12/2024 13:00				
1/12/2024 13:10				

Site Time	Velocity A		Velocity B	
	Vel.x ft/s	Vel.y ft/s	Vel.x ft/s	Vel.y ft/s
America/Chicago				
1/12/2024 13:20				
1/12/2024 13:30				
1/12/2024 13:40				
1/12/2024 13:50				
1/12/2024 14:00				
1/12/2024 14:10				
1/12/2024 14:20				
1/12/2024 14:30				
1/12/2024 14:40				
1/12/2024 14:50				
1/12/2024 15:00				
1/12/2024 15:10				
1/12/2024 15:20				
1/12/2024 15:30				
1/12/2024 15:40				
1/12/2024 15:50				
1/12/2024 16:00				
1/12/2024 16:10				
1/12/2024 16:20				
1/12/2024 16:30				
1/12/2024 16:40				
1/12/2024 16:50				
1/12/2024 17:00				
1/12/2024 17:10				
1/12/2024 17:20				
1/12/2024 17:30				
1/12/2024 17:40				
1/12/2024 17:50				
1/12/2024 18:00				
1/12/2024 18:10				
1/12/2024 18:20				
1/12/2024 18:30				
1/12/2024 18:40				
1/12/2024 18:50				
1/12/2024 19:00				
1/12/2024 19:10				
1/12/2024 19:20				
1/12/2024 19:30				
1/12/2024 19:40				
1/12/2024 19:50				
1/12/2024 20:00				
1/12/2024 20:10				
1/12/2024 20:20				
1/12/2024 20:30				
1/12/2024 20:40				
1/12/2024 20:50				
1/12/2024 21:00				
1/12/2024 21:10				
1/12/2024 21:20				
1/12/2024 21:30				
1/12/2024 21:40				
1/12/2024 21:50				

Site Time	Velocity A		Velocity B	
	Vel.x ft/s	Vel.y ft/s	Vel.x ft/s	Vel.y ft/s
America/Chicago				
1/12/2024 22:00				
1/12/2024 22:10				
1/12/2024 22:20				
1/12/2024 22:30				
1/12/2024 22:40				
1/12/2024 22:50				
1/12/2024 23:00				
1/12/2024 23:10				
1/12/2024 23:20				
1/12/2024 23:30				
1/12/2024 23:40				
1/12/2024 23:50				
1/13/2024 0:00				
1/13/2024 0:10				
1/13/2024 0:20				
1/13/2024 0:30				
1/13/2024 0:40				
1/13/2024 0:50				
1/13/2024 1:00				
1/13/2024 1:10				
1/13/2024 1:20				
1/13/2024 1:30				
1/13/2024 1:40				
1/13/2024 1:50				
1/13/2024 2:00				
1/13/2024 2:10				
1/13/2024 2:20				
1/13/2024 2:30				
1/13/2024 2:40				
1/13/2024 2:50				
1/13/2024 3:00				
1/13/2024 3:10				
1/13/2024 3:20				
1/13/2024 3:30				
1/13/2024 3:40				
1/13/2024 3:50				
1/13/2024 4:00				
1/13/2024 4:10				
1/13/2024 4:20				
1/13/2024 4:30				
1/13/2024 4:40				
1/13/2024 4:50				
1/13/2024 5:00				
1/13/2024 5:10				
1/13/2024 5:20				
1/13/2024 5:30				
1/13/2024 5:40				
1/13/2024 5:50				
1/13/2024 6:00				
1/13/2024 6:10				
1/13/2024 6:20				
1/13/2024 6:30				

Site Time	Velocity A		Velocity B	
	Vel.x ft/s	Vel.y ft/s	Vel.x ft/s	Vel.y ft/s
America/Chicago				
1/13/2024 6:40				
1/13/2024 6:50				
1/13/2024 7:00				
1/13/2024 7:10				
1/13/2024 7:20				
1/13/2024 7:30				
1/13/2024 7:40				
1/13/2024 7:50				
1/13/2024 8:00				
1/13/2024 8:10				
1/13/2024 8:20				
1/13/2024 8:30				
1/13/2024 8:40				
1/13/2024 8:50				
1/13/2024 9:00				
1/13/2024 9:10				
1/13/2024 9:20				
1/13/2024 9:30				
1/13/2024 9:40				
1/13/2024 9:50				
1/13/2024 10:00				
1/13/2024 10:10				
1/13/2024 10:20				
1/13/2024 10:30				
1/13/2024 10:40				
1/13/2024 10:50				
1/13/2024 11:00				
1/13/2024 11:10				
1/13/2024 11:20				
1/13/2024 11:30				
1/13/2024 11:40				
1/13/2024 11:50				
1/13/2024 12:00				
1/13/2024 12:10				
1/13/2024 12:20				
1/13/2024 12:30				
1/13/2024 12:40				
1/13/2024 12:50				
1/13/2024 13:00				
1/13/2024 13:10				
1/13/2024 13:20				
1/13/2024 13:30				
1/13/2024 13:40				
1/13/2024 13:50				
1/13/2024 14:00				
1/13/2024 14:10				
1/13/2024 14:20				
1/13/2024 14:30				
1/13/2024 14:40				
1/13/2024 14:50				
1/13/2024 15:00				
1/13/2024 15:10				

Site Time	Velocity A		Velocity B	
	Vel.x ft/s	Vel.y ft/s	Vel.x ft/s	Vel.y ft/s
America/Chicago				
1/13/2024 15:20				
1/13/2024 15:30				
1/13/2024 15:40				
1/13/2024 15:50				
1/13/2024 16:00				
1/13/2024 16:10				
1/13/2024 16:20				
1/13/2024 16:30				
1/13/2024 16:40				
1/13/2024 16:50				
1/13/2024 17:00				
1/13/2024 17:10				
1/13/2024 17:20				
1/13/2024 17:30				
1/13/2024 17:40				
1/13/2024 17:50				
1/13/2024 18:00				
1/13/2024 18:10				
1/13/2024 18:20				
1/13/2024 18:30				
1/13/2024 18:40				
1/13/2024 18:50				
1/13/2024 19:00				
1/13/2024 19:10				
1/13/2024 19:20				
1/13/2024 19:30				
1/13/2024 19:40				
1/13/2024 19:50				
1/13/2024 20:00				
1/13/2024 20:10				
1/13/2024 20:20				
1/13/2024 20:30				
1/13/2024 20:40				
1/13/2024 20:50				
1/13/2024 21:00				
1/13/2024 21:10				
1/13/2024 21:20				
1/13/2024 21:30				
1/13/2024 21:40				
1/13/2024 21:50				
1/13/2024 22:00				
1/13/2024 22:10				
1/13/2024 22:20				
1/13/2024 22:30				
1/13/2024 22:40				
1/13/2024 22:50				
1/13/2024 23:00				
1/13/2024 23:10				
1/13/2024 23:20				
1/13/2024 23:30				
1/13/2024 23:40				
1/13/2024 23:50				

Site Time	Velocity A		Velocity B	
	Vel.x ft/s	Vel.y ft/s	Vel.x ft/s	Vel.y ft/s
America/Chicago				
1/14/2024 0:00				
1/14/2024 0:10				
1/14/2024 0:20				
1/14/2024 0:30				
1/14/2024 0:40				
1/14/2024 0:50				
1/14/2024 1:00				
1/14/2024 1:10				
1/14/2024 1:20				
1/14/2024 1:30				
1/14/2024 1:40				
1/14/2024 1:50				
1/14/2024 2:00				
1/14/2024 2:10				
1/14/2024 2:20				
1/14/2024 2:30				
1/14/2024 2:40				
1/14/2024 2:50				
1/14/2024 3:00				
1/14/2024 3:10				
1/14/2024 3:20				
1/14/2024 3:30				
1/14/2024 3:40				
1/14/2024 3:50				
1/14/2024 4:00				
1/14/2024 4:10				
1/14/2024 4:20				
1/14/2024 4:30				
1/14/2024 4:40				
1/14/2024 4:50				
1/14/2024 5:00				
1/14/2024 5:10				
1/14/2024 5:20				
1/14/2024 5:30				
1/14/2024 5:40				
1/14/2024 5:50				
1/14/2024 6:00				
1/14/2024 6:10				
1/14/2024 6:20				
1/14/2024 6:30				
1/14/2024 6:40				
1/14/2024 6:50				
1/14/2024 7:00				
1/14/2024 7:10				
1/14/2024 7:20				
1/14/2024 7:30				
1/14/2024 7:40				
1/14/2024 7:50				
1/14/2024 8:00				
1/14/2024 8:10				
1/14/2024 8:20				
1/14/2024 8:30				

Site Time	Velocity A		Velocity B	
	Vel.x ft/s	Vel.y ft/s	Vel.x ft/s	Vel.y ft/s
America/Chicago				
1/14/2024 8:40				
1/14/2024 8:50				
1/14/2024 9:00				
1/14/2024 9:10				
1/14/2024 9:20				
1/14/2024 9:30				
1/14/2024 9:40				
1/14/2024 9:50				
1/14/2024 10:00				
1/14/2024 10:10				
1/14/2024 10:20				
1/14/2024 10:30				
1/14/2024 10:40				
1/14/2024 10:50				
1/14/2024 11:00				
1/14/2024 11:10				
1/14/2024 11:20				
1/14/2024 11:30				
1/14/2024 11:40				
1/14/2024 11:50				
1/14/2024 12:00				
1/14/2024 12:10				
1/14/2024 12:20				
1/14/2024 12:30				
1/14/2024 12:40				
1/14/2024 12:50				
1/14/2024 13:00				
1/14/2024 13:10				
1/14/2024 13:20				
1/14/2024 13:30				
1/14/2024 13:40				
1/14/2024 13:50				
1/14/2024 14:00				
1/14/2024 14:10				
1/14/2024 14:20				
1/14/2024 14:30				
1/14/2024 14:40				
1/14/2024 14:50				
1/14/2024 15:00				
1/14/2024 15:10				
1/14/2024 15:20				
1/14/2024 15:30				
1/14/2024 15:40				
1/14/2024 15:50				
1/14/2024 16:00				
1/14/2024 16:10				
1/14/2024 16:20				
1/14/2024 16:30				
1/14/2024 16:40				
1/14/2024 16:50				
1/14/2024 17:00				
1/14/2024 17:10				

Site Time	Velocity A		Velocity B	
	Vel.x ft/s	Vel.y ft/s	Vel.x ft/s	Vel.y ft/s
America/Chicago				
1/14/2024 17:20				
1/14/2024 17:30				
1/14/2024 17:40				
1/14/2024 17:50				
1/14/2024 18:00				
1/14/2024 18:10				
1/14/2024 18:20				
1/14/2024 18:30				
1/14/2024 18:40				
1/14/2024 18:50				
1/14/2024 19:00				
1/14/2024 19:10				
1/14/2024 19:20				
1/14/2024 19:30				
1/14/2024 19:40				
1/14/2024 19:50				
1/14/2024 20:00				
1/14/2024 20:10				
1/14/2024 20:20				
1/14/2024 20:30				
1/14/2024 20:40				
1/14/2024 20:50				
1/14/2024 21:00				
1/14/2024 21:10				
1/14/2024 21:20				
1/14/2024 21:30				
1/14/2024 21:40				
1/14/2024 21:50				
1/14/2024 22:00				
1/14/2024 22:10				
1/14/2024 22:20				
1/14/2024 22:30				
1/14/2024 22:40				
1/14/2024 22:50				
1/14/2024 23:00				
1/14/2024 23:10				
1/14/2024 23:20				
1/14/2024 23:30				
1/14/2024 23:40				
1/14/2024 23:50				
1/15/2024 0:00				
1/15/2024 0:10				
1/15/2024 0:20				
1/15/2024 0:30				
1/15/2024 0:40				
1/15/2024 0:50				
1/15/2024 1:00				
1/15/2024 1:10				
1/15/2024 1:20				
1/15/2024 1:30				
1/15/2024 1:40				
1/15/2024 1:50				

Site Time	Velocity A		Velocity B	
	Vel.x ft/s	Vel.y ft/s	Vel.x ft/s	Vel.y ft/s
America/Chicago				
1/15/2024 2:00				
1/15/2024 2:10				
1/15/2024 2:20				
1/15/2024 2:30				
1/15/2024 2:40				
1/15/2024 2:50				
1/15/2024 3:00				
1/15/2024 3:10				
1/15/2024 3:20				
1/15/2024 3:30				
1/15/2024 3:40				
1/15/2024 3:50				
1/15/2024 4:00				
1/15/2024 4:10				
1/15/2024 4:20				
1/15/2024 4:30				
1/15/2024 4:40				
1/15/2024 4:50				
1/15/2024 5:00				
1/15/2024 5:10				
1/15/2024 5:20				
1/15/2024 5:30				
1/15/2024 5:40				
1/15/2024 5:50				
1/15/2024 6:00				
1/15/2024 6:10				
1/15/2024 6:20				
1/15/2024 6:30				
1/15/2024 6:40				
1/15/2024 6:50				
1/15/2024 7:00				
1/15/2024 7:10				
1/15/2024 7:20				
1/15/2024 7:30				
1/15/2024 7:40				
1/15/2024 7:50				
1/15/2024 8:00				
1/15/2024 8:10				
1/15/2024 8:20				
1/15/2024 8:30				
1/15/2024 8:40				
1/15/2024 8:50				
1/15/2024 9:00				
1/15/2024 9:10				
1/15/2024 9:20				
1/15/2024 9:30				
1/15/2024 9:40				
1/15/2024 9:50				
1/15/2024 10:00				
1/15/2024 10:10				
1/15/2024 10:20				
1/15/2024 10:30				

Site Time	Velocity A		Velocity B	
	Vel.x ft/s	Vel.y ft/s	Vel.x ft/s	Vel.y ft/s
America/Chicago				
1/15/2024 10:40				
1/15/2024 10:50				
1/15/2024 11:00				
1/15/2024 11:10				
1/15/2024 11:20				
1/15/2024 11:30				
1/15/2024 11:40				
1/15/2024 11:50				
1/15/2024 12:00				
1/15/2024 12:10				
1/15/2024 12:20				
1/15/2024 12:30				
1/15/2024 12:40				
1/15/2024 12:50				
1/15/2024 13:00				
1/15/2024 13:10				
1/15/2024 13:20				
1/15/2024 13:30				
1/15/2024 13:40				
1/15/2024 13:50				
1/15/2024 14:00				
1/15/2024 14:10				
1/15/2024 14:20				
1/15/2024 14:30				
1/15/2024 14:40				
1/15/2024 14:50				
1/15/2024 15:00				
1/15/2024 15:10				
1/15/2024 15:20				
1/15/2024 15:30				
1/15/2024 15:40				
1/15/2024 15:50				
1/15/2024 16:00				
1/15/2024 16:10				
1/15/2024 16:20				
1/15/2024 16:30				
1/15/2024 16:40				
1/15/2024 16:50				
1/15/2024 17:00				
1/15/2024 17:10				
1/15/2024 17:20				
1/15/2024 17:30				
1/15/2024 17:40				
1/15/2024 17:50				
1/15/2024 18:00				
1/15/2024 18:10				
1/15/2024 18:20				
1/15/2024 18:30				
1/15/2024 18:40				
1/15/2024 18:50				
1/15/2024 19:00				
1/15/2024 19:10				

Site Time	Velocity A		Velocity B	
	Vel.x ft/s	Vel.y ft/s	Vel.x ft/s	Vel.y ft/s
America/Chicago				
1/15/2024 19:20				
1/15/2024 19:30				
1/15/2024 19:40				
1/15/2024 19:50				
1/15/2024 20:00				
1/15/2024 20:10				
1/15/2024 20:20				
1/15/2024 20:30				
1/15/2024 20:40				
1/15/2024 20:50				
1/15/2024 21:00				
1/15/2024 21:10				
1/15/2024 21:20				
1/15/2024 21:30				
1/15/2024 21:40				
1/15/2024 21:50				
1/15/2024 22:00				
1/15/2024 22:10				
1/15/2024 22:20				
1/15/2024 22:30				
1/15/2024 22:40				
1/15/2024 22:50				
1/15/2024 23:00				
1/15/2024 23:10				
1/15/2024 23:20				
1/15/2024 23:30				
1/15/2024 23:40				
1/15/2024 23:50				
1/16/2024 0:00				
1/16/2024 0:10				
1/16/2024 0:20				
1/16/2024 0:30				
1/16/2024 0:40				
1/16/2024 0:50				
1/16/2024 1:00				
1/16/2024 1:10				
1/16/2024 1:20				
1/16/2024 1:30				
1/16/2024 1:40				
1/16/2024 1:50				
1/16/2024 2:00				
1/16/2024 2:10				
1/16/2024 2:20				
1/16/2024 2:30				
1/16/2024 2:40				
1/16/2024 2:50				
1/16/2024 3:00				
1/16/2024 3:10				
1/16/2024 3:20				
1/16/2024 3:30				
1/16/2024 3:40				
1/16/2024 3:50				

Site Time	Velocity A		Velocity B	
	Vel.x ft/s	Vel.y ft/s	Vel.x ft/s	Vel.y ft/s
America/Chicago				
1/16/2024 4:00				
1/16/2024 4:10				
1/16/2024 4:20				
1/16/2024 4:30				
1/16/2024 4:40				
1/16/2024 4:50				
1/16/2024 5:00				
1/16/2024 5:10				
1/16/2024 5:20				
1/16/2024 5:30				
1/16/2024 5:40				
1/16/2024 5:50				
1/16/2024 6:00				
1/16/2024 6:10				
1/16/2024 6:20				
1/16/2024 6:30				
1/16/2024 6:40				
1/16/2024 6:50				
1/16/2024 7:00				
1/16/2024 7:10				
1/16/2024 7:20				
1/16/2024 7:30				
1/16/2024 7:40				
1/16/2024 7:50				
1/16/2024 8:00				
1/16/2024 8:10				
1/16/2024 8:20				
1/16/2024 8:30				
1/16/2024 8:40				
1/16/2024 8:50				
1/16/2024 9:00				
1/16/2024 9:10				
1/16/2024 9:20				
1/16/2024 9:30				
1/16/2024 9:40				
1/16/2024 9:50				
1/16/2024 10:00				
1/16/2024 10:10				
1/16/2024 10:20				
1/16/2024 10:30				
1/16/2024 10:40				
1/16/2024 10:50				
1/16/2024 11:00				
1/16/2024 11:10				
1/16/2024 11:20				
1/16/2024 11:30				
1/16/2024 11:40				
1/16/2024 11:50				
1/16/2024 12:00				
1/16/2024 12:10				
1/16/2024 12:20				
1/16/2024 12:30				

Site Time	Velocity A		Velocity B	
	Vel.x ft/s	Vel.y ft/s	Vel.x ft/s	Vel.y ft/s
America/Chicago				
1/16/2024 12:40				
1/16/2024 12:50				
1/16/2024 13:00				
1/16/2024 13:10				
1/16/2024 13:20				
1/16/2024 13:30				
1/16/2024 13:40				
1/16/2024 13:50				
1/16/2024 14:00				
1/16/2024 14:10				
1/16/2024 14:20				
1/16/2024 14:30				
1/16/2024 14:40				
1/16/2024 14:50				
1/16/2024 15:00				
1/16/2024 15:10				
1/16/2024 15:20				
1/16/2024 15:30				
1/16/2024 15:40				
1/16/2024 15:50				
1/16/2024 16:00				
1/16/2024 16:10				
1/16/2024 16:20				
1/16/2024 16:30				
1/16/2024 16:40				
1/16/2024 16:50				
1/16/2024 17:00				
1/16/2024 17:10				
1/16/2024 17:20				
1/16/2024 17:30				
1/16/2024 17:40				
1/16/2024 17:50				
1/16/2024 18:00				
1/16/2024 18:10				
1/16/2024 18:20				
1/16/2024 18:30				
1/16/2024 18:40				
1/16/2024 18:50				
1/16/2024 19:00				
1/16/2024 19:10				
1/16/2024 19:20				
1/16/2024 19:30				
1/16/2024 19:40				
1/16/2024 19:50				
1/16/2024 20:00				
1/16/2024 20:10				
1/16/2024 20:20				
1/16/2024 20:30				
1/16/2024 20:40				
1/16/2024 20:50				
1/16/2024 21:00				
1/16/2024 21:10				

Site Time	Velocity A		Velocity B	
	Vel.x ft/s	Vel.y ft/s	Vel.x ft/s	Vel.y ft/s
America/Chicago				
1/16/2024 21:20				
1/16/2024 21:30				
1/16/2024 21:40				
1/16/2024 21:50				
1/16/2024 22:00				
1/16/2024 22:10				
1/16/2024 22:20				
1/16/2024 22:30				
1/16/2024 22:40				
1/16/2024 22:50				
1/16/2024 23:00				
1/16/2024 23:10				
1/16/2024 23:20				
1/16/2024 23:30				
1/16/2024 23:40				
1/16/2024 23:50				
1/17/2024 0:00				
1/17/2024 0:10				
1/17/2024 0:20				
1/17/2024 0:30				
1/17/2024 0:40				
1/17/2024 0:50				
1/17/2024 1:00				
1/17/2024 1:10				
1/17/2024 1:20				
1/17/2024 1:30				
1/17/2024 1:40				
1/17/2024 1:50				
1/17/2024 2:00				
1/17/2024 2:10				
1/17/2024 2:20				
1/17/2024 2:30				
1/17/2024 2:40				
1/17/2024 2:50				
1/17/2024 3:00				
1/17/2024 3:10				
1/17/2024 3:20				
1/17/2024 3:30				
1/17/2024 3:40				
1/17/2024 3:50				
1/17/2024 4:00				
1/17/2024 4:10				
1/17/2024 4:20				
1/17/2024 4:30				
1/17/2024 4:40				
1/17/2024 4:50				
1/17/2024 5:00				
1/17/2024 5:10				
1/17/2024 5:20				
1/17/2024 5:30				
1/17/2024 5:40				
1/17/2024 5:50				

Site Time	Velocity A		Velocity B	
	Vel.x ft/s	Vel.y ft/s	Vel.x ft/s	Vel.y ft/s
America/Chicago				
1/17/2024 6:00				
1/17/2024 6:10				
1/17/2024 6:20				
1/17/2024 6:30				
1/17/2024 6:40				
1/17/2024 6:50				
1/17/2024 7:00				
1/17/2024 7:10				
1/17/2024 7:20				
1/17/2024 7:30				
1/17/2024 7:40				
1/17/2024 7:50				
1/17/2024 8:00				
1/17/2024 8:10				
1/17/2024 8:20				
1/17/2024 8:30				
1/17/2024 8:40				
1/17/2024 8:50				
1/17/2024 9:00				
1/17/2024 9:10				
1/17/2024 9:20				
1/17/2024 9:30				
1/17/2024 9:40				
1/17/2024 9:50				
1/17/2024 10:00				
1/17/2024 10:10				
1/17/2024 10:20				
1/17/2024 10:30				
1/17/2024 10:40				
1/17/2024 10:50				
1/17/2024 11:00				
1/17/2024 11:10				
1/17/2024 11:20				
1/17/2024 11:30				
1/17/2024 11:40				
1/17/2024 11:50				
1/17/2024 12:00				
1/17/2024 12:10				
1/17/2024 12:20				
1/17/2024 12:30				
1/17/2024 12:40				
1/17/2024 12:50				
1/17/2024 13:00				
1/17/2024 13:10				
1/17/2024 13:20				
1/17/2024 13:30				
1/17/2024 13:40				
1/17/2024 13:50				
1/17/2024 14:00				
1/17/2024 14:10				
1/17/2024 14:20				
1/17/2024 14:30				

Site Time	Velocity A		Velocity B	
	Vel.x ft/s	Vel.y ft/s	Vel.x ft/s	Vel.y ft/s
America/Chicago				
1/17/2024 14:40				
1/17/2024 14:50				
1/17/2024 15:00				
1/17/2024 15:10				
1/17/2024 15:20				
1/17/2024 15:30				
1/17/2024 15:40				
1/17/2024 15:50				
1/17/2024 16:00				
1/17/2024 16:10				
1/17/2024 16:20				
1/17/2024 16:30				
1/17/2024 16:40				
1/17/2024 16:50				
1/17/2024 17:00				
1/17/2024 17:10				
1/17/2024 17:20				
1/17/2024 17:30				
1/17/2024 17:40				
1/17/2024 17:50				
1/17/2024 18:00				
1/17/2024 18:10				
1/17/2024 18:20				
1/17/2024 18:30				
1/17/2024 18:40				
1/17/2024 18:50				
1/17/2024 19:00				
1/17/2024 19:10				
1/17/2024 19:20				
1/17/2024 19:30				
1/17/2024 19:40				
1/17/2024 19:50				
1/17/2024 20:00				
1/17/2024 20:10				
1/17/2024 20:20				
1/17/2024 20:30				
1/17/2024 20:40				
1/17/2024 20:50				
1/17/2024 21:00				
1/17/2024 21:10				
1/17/2024 21:20				
1/17/2024 21:30				
1/17/2024 21:40				
1/17/2024 21:50				
1/17/2024 22:00				
1/17/2024 22:10				
1/17/2024 22:20				
1/17/2024 22:30				
1/17/2024 22:40				
1/17/2024 22:50				
1/17/2024 23:00				
1/17/2024 23:10				

Site Time	Velocity A		Velocity B	
	Vel.x ft/s	Vel.y ft/s	Vel.x ft/s	Vel.y ft/s
America/Chicago				
1/17/2024 23:20				
1/17/2024 23:30				
1/17/2024 23:40				
1/17/2024 23:50				
1/18/2024 0:00				
1/18/2024 0:10				
1/18/2024 0:20				
1/18/2024 0:30				
1/18/2024 0:40				
1/18/2024 0:50				
1/18/2024 1:00				
1/18/2024 1:10				
1/18/2024 1:20				
1/18/2024 1:30				
1/18/2024 1:40				
1/18/2024 1:50				
1/18/2024 2:00				
1/18/2024 2:10				
1/18/2024 2:20				
1/18/2024 2:30				
1/18/2024 2:40				
1/18/2024 2:50				
1/18/2024 3:00				
1/18/2024 3:10				
1/18/2024 3:20				
1/18/2024 3:30				
1/18/2024 3:40				
1/18/2024 3:50				
1/18/2024 4:00				
1/18/2024 4:10				
1/18/2024 4:20				
1/18/2024 4:30				
1/18/2024 4:40				
1/18/2024 4:50				
1/18/2024 5:00				
1/18/2024 5:10				
1/18/2024 5:20				
1/18/2024 5:30				
1/18/2024 5:40				
1/18/2024 5:50				
1/18/2024 6:00				
1/18/2024 6:10				
1/18/2024 6:20				
1/18/2024 6:30				
1/18/2024 6:40				
1/18/2024 6:50				
1/18/2024 7:00				
1/18/2024 7:10				
1/18/2024 7:20				
1/18/2024 7:30				
1/18/2024 7:40				
1/18/2024 7:50				

Site Time	Velocity A		Velocity B	
	Vel.x ft/s	Vel.y ft/s	Vel.x ft/s	Vel.y ft/s
America/Chicago				
1/18/2024 8:00				
1/18/2024 8:10				
1/18/2024 8:20				
1/18/2024 8:30				
1/18/2024 8:40				
1/18/2024 8:50				
1/18/2024 9:00				
1/18/2024 9:10				
1/18/2024 9:20				
1/18/2024 9:30				
1/18/2024 9:40				
1/18/2024 9:50				
1/18/2024 10:00				
1/18/2024 10:10				
1/18/2024 10:20				
1/18/2024 10:30				
1/18/2024 10:40				
1/18/2024 10:50				
1/18/2024 11:00				
1/18/2024 11:10				
1/18/2024 11:20				
1/18/2024 11:30				
1/18/2024 11:40				
1/18/2024 11:50				
1/18/2024 12:00				
1/18/2024 12:10				
1/18/2024 12:20				
1/18/2024 12:30				
1/18/2024 12:40				
1/18/2024 12:50				
1/18/2024 13:00				
1/18/2024 13:10				
1/18/2024 13:20				
1/18/2024 13:30				
1/18/2024 13:40				
1/18/2024 13:50				
1/18/2024 14:00				
1/18/2024 14:10				
1/18/2024 14:20				
1/18/2024 14:30				
1/18/2024 14:40				
1/18/2024 14:50				
1/18/2024 15:00				
1/18/2024 15:10				
1/18/2024 15:20				
1/18/2024 15:30				
1/18/2024 15:40				
1/18/2024 15:50				
1/18/2024 16:00				
1/18/2024 16:10				
1/18/2024 16:20				
1/18/2024 16:30				

Site Time	Velocity A		Velocity B	
	Vel.x ft/s	Vel.y ft/s	Vel.x ft/s	Vel.y ft/s
America/Chicago				
1/18/2024 16:40				
1/18/2024 16:50				
1/18/2024 17:00				
1/18/2024 17:10				
1/18/2024 17:20				
1/18/2024 17:30				
1/18/2024 17:40				
1/18/2024 17:50				
1/18/2024 18:00				
1/18/2024 18:10				
1/18/2024 18:20				
1/18/2024 18:30				
1/18/2024 18:40				
1/18/2024 18:50				
1/18/2024 19:00				
1/18/2024 19:10				
1/18/2024 19:20				
1/18/2024 19:30				
1/18/2024 19:40				
1/18/2024 19:50				
1/18/2024 20:00				
1/18/2024 20:10				
1/18/2024 20:20				
1/18/2024 20:30				
1/18/2024 20:40				
1/18/2024 20:50				
1/18/2024 21:00				
1/18/2024 21:10				
1/18/2024 21:20				
1/18/2024 21:30				
1/18/2024 21:40				
1/18/2024 21:50				
1/18/2024 22:00				
1/18/2024 22:10				
1/18/2024 22:20				
1/18/2024 22:30				
1/18/2024 22:40				
1/18/2024 22:50				
1/18/2024 23:00				
1/18/2024 23:10				
1/18/2024 23:20				
1/18/2024 23:30				
1/18/2024 23:40				
1/18/2024 23:50				
1/19/2024 0:00				
1/19/2024 0:10				
1/19/2024 0:20				
1/19/2024 0:30				
1/19/2024 0:40				
1/19/2024 0:50				
1/19/2024 1:00				
1/19/2024 1:10				

Site Time	Velocity A		Velocity B	
	Vel.x ft/s	Vel.y ft/s	Vel.x ft/s	Vel.y ft/s
America/Chicago				
1/19/2024 1:20				
1/19/2024 1:30				
1/19/2024 1:40				
1/19/2024 1:50				
1/19/2024 2:00				
1/19/2024 2:10				
1/19/2024 2:20				
1/19/2024 2:30				
1/19/2024 2:40				
1/19/2024 2:50				
1/19/2024 3:00				
1/19/2024 3:10				
1/19/2024 3:20				
1/19/2024 3:30				
1/19/2024 3:40				
1/19/2024 3:50				
1/19/2024 4:00				
1/19/2024 4:10				
1/19/2024 4:20				
1/19/2024 4:30				
1/19/2024 4:40				
1/19/2024 4:50				
1/19/2024 5:00				
1/19/2024 5:10				
1/19/2024 5:20				
1/19/2024 5:30				
1/19/2024 5:40				
1/19/2024 5:50				
1/19/2024 6:00				
1/19/2024 6:10				
1/19/2024 6:20				
1/19/2024 6:30				
1/19/2024 6:40				
1/19/2024 6:50				
1/19/2024 7:00				
1/19/2024 7:10				
1/19/2024 7:20				
1/19/2024 7:30				
1/19/2024 7:40				
1/19/2024 7:50				
1/19/2024 8:00				
1/19/2024 8:10				
1/19/2024 8:20				
1/19/2024 8:30				
1/19/2024 8:40				
1/19/2024 8:50				
1/19/2024 9:00				
1/19/2024 9:10				
1/19/2024 9:20				
1/19/2024 9:30				
1/19/2024 9:40				
1/19/2024 9:50				

Site Time	Velocity A		Velocity B	
	Vel.x ft/s	Vel.y ft/s	Vel.x ft/s	Vel.y ft/s
America/Chicago				
1/19/2024 10:00				
1/19/2024 10:10				
1/19/2024 10:20				
1/19/2024 10:30				
1/19/2024 10:40				
1/19/2024 10:50				
1/19/2024 11:00				
1/19/2024 11:10				
1/19/2024 11:20				
1/19/2024 11:30				
1/19/2024 11:40				
1/19/2024 11:50				
1/19/2024 12:00				
1/19/2024 12:10				
1/19/2024 12:20				
1/19/2024 12:30				
1/19/2024 12:40				
1/19/2024 12:50				
1/19/2024 13:00				
1/19/2024 13:10				
1/19/2024 13:20				
1/19/2024 13:30				
1/19/2024 13:40				
1/19/2024 13:50				
1/19/2024 14:00				
1/19/2024 14:10				
1/19/2024 14:20				
1/19/2024 14:30				
1/19/2024 14:40				
1/19/2024 14:50				
1/19/2024 15:00				
1/19/2024 15:10				
1/19/2024 15:20				
1/19/2024 15:30				
1/19/2024 15:40				
1/19/2024 15:50				
1/19/2024 16:00				
1/19/2024 16:10				
1/19/2024 16:20				
1/19/2024 16:30				
1/19/2024 16:40				
1/19/2024 16:50				
1/19/2024 17:00				
1/19/2024 17:10				
1/19/2024 17:20				
1/19/2024 17:30				
1/19/2024 17:40				
1/19/2024 17:50				
1/19/2024 18:00				
1/19/2024 18:10				
1/19/2024 18:20				
1/19/2024 18:30				

Site Time	Velocity A		Velocity B	
	Vel.x ft/s	Vel.y ft/s	Vel.x ft/s	Vel.y ft/s
America/Chicago				
1/19/2024 18:40				
1/19/2024 18:50				
1/19/2024 19:00				
1/19/2024 19:10				
1/19/2024 19:20				
1/19/2024 19:30				
1/19/2024 19:40				
1/19/2024 19:50				
1/19/2024 20:00				
1/19/2024 20:10				
1/19/2024 20:20				
1/19/2024 20:30				
1/19/2024 20:40				
1/19/2024 20:50				
1/19/2024 21:00				
1/19/2024 21:10				
1/19/2024 21:20				
1/19/2024 21:30				
1/19/2024 21:40				
1/19/2024 21:50				
1/19/2024 22:00				
1/19/2024 22:10				
1/19/2024 22:20				
1/19/2024 22:30				
1/19/2024 22:40				
1/19/2024 22:50				
1/19/2024 23:00				
1/19/2024 23:10				
1/19/2024 23:20				
1/19/2024 23:30				
1/19/2024 23:40				
1/19/2024 23:50				
1/20/2024 0:00				
1/20/2024 0:10				
1/20/2024 0:20				
1/20/2024 0:30				
1/20/2024 0:40				
1/20/2024 0:50				
1/20/2024 1:00				
1/20/2024 1:10				
1/20/2024 1:20				
1/20/2024 1:30				
1/20/2024 1:40				
1/20/2024 1:50				
1/20/2024 2:00				
1/20/2024 2:10				
1/20/2024 2:20				
1/20/2024 2:30				
1/20/2024 2:40				
1/20/2024 2:50				
1/20/2024 3:00				
1/20/2024 3:10				

Site Time	Velocity A		Velocity B	
	Vel.x ft/s	Vel.y ft/s	Vel.x ft/s	Vel.y ft/s
America/Chicago				
1/20/2024 3:20				
1/20/2024 3:30				
1/20/2024 3:40				
1/20/2024 3:50				
1/20/2024 4:00				
1/20/2024 4:10				
1/20/2024 4:20				
1/20/2024 4:30				
1/20/2024 4:40				
1/20/2024 4:50				
1/20/2024 5:00				
1/20/2024 5:10				
1/20/2024 5:20				
1/20/2024 5:30				
1/20/2024 5:40				
1/20/2024 5:50				
1/20/2024 6:00				
1/20/2024 6:10				
1/20/2024 6:20				
1/20/2024 6:30				
1/20/2024 6:40				
1/20/2024 6:50				
1/20/2024 7:00				
1/20/2024 7:10				
1/20/2024 7:20				
1/20/2024 7:30				
1/20/2024 7:40				
1/20/2024 7:50				
1/20/2024 8:00				
1/20/2024 8:10				
1/20/2024 8:20				
1/20/2024 8:30				
1/20/2024 8:40				
1/20/2024 8:50				
1/20/2024 9:00				
1/20/2024 9:10				
1/20/2024 9:20				
1/20/2024 9:30				
1/20/2024 9:40				
1/20/2024 9:50				
1/20/2024 10:00				
1/20/2024 10:10				
1/20/2024 10:20				
1/20/2024 10:30				
1/20/2024 10:40				
1/20/2024 10:50				
1/20/2024 11:00				
1/20/2024 11:10				
1/20/2024 11:20				
1/20/2024 11:30				
1/20/2024 11:40				
1/20/2024 11:50				

Site Time	Velocity A		Velocity B	
	Vel.x ft/s	Vel.y ft/s	Vel.x ft/s	Vel.y ft/s
America/Chicago				
1/20/2024 12:00				
1/20/2024 12:10				
1/20/2024 12:20				
1/20/2024 12:30				
1/20/2024 12:40				
1/20/2024 12:50				
1/20/2024 13:00				
1/20/2024 13:10				
1/20/2024 13:20				
1/20/2024 13:30				
1/20/2024 13:40				
1/20/2024 13:50				
1/20/2024 14:00				
1/20/2024 14:10				
1/20/2024 14:20				
1/20/2024 14:30				
1/20/2024 14:40				
1/20/2024 14:50				
1/20/2024 15:00				
1/20/2024 15:10				
1/20/2024 15:20				
1/20/2024 15:30				
1/20/2024 15:40				
1/20/2024 15:50				
1/20/2024 16:00				
1/20/2024 16:10				
1/20/2024 16:20				
1/20/2024 16:30				
1/20/2024 16:40				
1/20/2024 16:50				
1/20/2024 17:00				
1/20/2024 17:10				
1/20/2024 17:20				
1/20/2024 17:30				
1/20/2024 17:40				
1/20/2024 17:50				
1/20/2024 18:00				
1/20/2024 18:10				
1/20/2024 18:20				
1/20/2024 18:30				
1/20/2024 18:40				
1/20/2024 18:50				
1/20/2024 19:00				
1/20/2024 19:10				
1/20/2024 19:20				
1/20/2024 19:30				
1/20/2024 19:40				
1/20/2024 19:50				
1/20/2024 20:00				
1/20/2024 20:10				
1/20/2024 20:20				
1/20/2024 20:30				

Site Time	Velocity A		Velocity B	
	Vel.x ft/s	Vel.y ft/s	Vel.x ft/s	Vel.y ft/s
America/Chicago				
1/20/2024 20:40				
1/20/2024 20:50				
1/20/2024 21:00				
1/20/2024 21:10				
1/20/2024 21:20				
1/20/2024 21:30				
1/20/2024 21:40				
1/20/2024 21:50				
1/20/2024 22:00				
1/20/2024 22:10				
1/20/2024 22:20				
1/20/2024 22:30				
1/20/2024 22:40				
1/20/2024 22:50				
1/20/2024 23:00				
1/20/2024 23:10				
1/20/2024 23:20				
1/20/2024 23:30				
1/20/2024 23:40				
1/20/2024 23:50				
1/21/2024 0:00				
1/21/2024 0:10				
1/21/2024 0:20				
1/21/2024 0:30				
1/21/2024 0:40				
1/21/2024 0:50				
1/21/2024 1:00				
1/21/2024 1:10				
1/21/2024 1:20				
1/21/2024 1:30				
1/21/2024 1:40				
1/21/2024 1:50				
1/21/2024 2:00				
1/21/2024 2:10				
1/21/2024 2:20				
1/21/2024 2:30				
1/21/2024 2:40				
1/21/2024 2:50				
1/21/2024 3:00				
1/21/2024 3:10				
1/21/2024 3:20				
1/21/2024 3:30				
1/21/2024 3:40				
1/21/2024 3:50				
1/21/2024 4:00				
1/21/2024 4:10				
1/21/2024 4:20				
1/21/2024 4:30				
1/21/2024 4:40				
1/21/2024 4:50				
1/21/2024 5:00				
1/21/2024 5:10				

Site Time	Velocity A		Velocity B	
	Vel.x ft/s	Vel.y ft/s	Vel.x ft/s	Vel.y ft/s
America/Chicago				
1/21/2024 5:20				
1/21/2024 5:30				
1/21/2024 5:40				
1/21/2024 5:50				
1/21/2024 6:00				
1/21/2024 6:10				
1/21/2024 6:20				
1/21/2024 6:30				
1/21/2024 6:40				
1/21/2024 6:50				
1/21/2024 7:00				
1/21/2024 7:10				
1/21/2024 7:20				
1/21/2024 7:30				
1/21/2024 7:40				
1/21/2024 7:50				
1/21/2024 8:00				
1/21/2024 8:10				
1/21/2024 8:20				
1/21/2024 8:30				
1/21/2024 8:40				
1/21/2024 8:50				
1/21/2024 9:00				
1/21/2024 9:10				
1/21/2024 9:20				
1/21/2024 9:30				
1/21/2024 9:40				
1/21/2024 9:50				
1/21/2024 10:00				
1/21/2024 10:10				
1/21/2024 10:20				
1/21/2024 10:30				
1/21/2024 10:40				
1/21/2024 10:50				
1/21/2024 11:00				
1/21/2024 11:10				
1/21/2024 11:20				
1/21/2024 11:30				
1/21/2024 11:40				
1/21/2024 11:50				
1/21/2024 12:00				
1/21/2024 12:10				
1/21/2024 12:20				
1/21/2024 12:30				
1/21/2024 12:40				
1/21/2024 12:50				
1/21/2024 13:00				
1/21/2024 13:10				
1/21/2024 13:20				
1/21/2024 13:30				
1/21/2024 13:40				
1/21/2024 13:50				

Site Time	Velocity A		Velocity B	
	Vel.x ft/s	Vel.y ft/s	Vel.x ft/s	Vel.y ft/s
America/Chicago				
1/21/2024 14:00				
1/21/2024 14:10				
1/21/2024 14:20				
1/21/2024 14:30				
1/21/2024 14:40				
1/21/2024 14:50				
1/21/2024 15:00				
1/21/2024 15:10				
1/21/2024 15:20				
1/21/2024 15:30				
1/21/2024 15:40				
1/21/2024 15:50				
1/21/2024 16:00				
1/21/2024 16:10				
1/21/2024 16:20				
1/21/2024 16:30				
1/21/2024 16:40				
1/21/2024 16:50				
1/21/2024 17:00				
1/21/2024 17:10				
1/21/2024 17:20				
1/21/2024 17:30				
1/21/2024 17:40				
1/21/2024 17:50				
1/21/2024 18:00				
1/21/2024 18:10				
1/21/2024 18:20				
1/21/2024 18:30				
1/21/2024 18:40				
1/21/2024 18:50				
1/21/2024 19:00				
1/21/2024 19:10				
1/21/2024 19:20				
1/21/2024 19:30				
1/21/2024 19:40				
1/21/2024 19:50				
1/21/2024 20:00				
1/21/2024 20:10				
1/21/2024 20:20				
1/21/2024 20:30				
1/21/2024 20:40				
1/21/2024 20:50				
1/21/2024 21:00				
1/21/2024 21:10				
1/21/2024 21:20				
1/21/2024 21:30				
1/21/2024 21:40				
1/21/2024 21:50				
1/21/2024 22:00				
1/21/2024 22:10				
1/21/2024 22:20				
1/21/2024 22:30				

Site Time	Velocity A		Velocity B	
	Vel.x ft/s	Vel.y ft/s	Vel.x ft/s	Vel.y ft/s
America/Chicago				
1/21/2024 22:40				
1/21/2024 22:50				
1/21/2024 23:00				
1/21/2024 23:10				
1/21/2024 23:20				
1/21/2024 23:30				
1/21/2024 23:40				
1/21/2024 23:50				
1/22/2024 0:00				
1/22/2024 0:10				
1/22/2024 0:20				
1/22/2024 0:30				
1/22/2024 0:40				
1/22/2024 0:50				
1/22/2024 1:00				
1/22/2024 1:10				
1/22/2024 1:20				
1/22/2024 1:30				
1/22/2024 1:40				
1/22/2024 1:50				
1/22/2024 2:00				
1/22/2024 2:10				
1/22/2024 2:20				
1/22/2024 2:30				
1/22/2024 2:40				
1/22/2024 2:50				
1/22/2024 3:00				
1/22/2024 3:10				
1/22/2024 3:20				
1/22/2024 3:30				
1/22/2024 3:40				
1/22/2024 3:50				
1/22/2024 4:00				
1/22/2024 4:10				
1/22/2024 4:20				
1/22/2024 4:30				
1/22/2024 4:40				
1/22/2024 4:50				
1/22/2024 5:00				
1/22/2024 5:10				
1/22/2024 5:20				
1/22/2024 5:30				
1/22/2024 5:40				
1/22/2024 5:50				
1/22/2024 6:00				
1/22/2024 6:10				
1/22/2024 6:20				
1/22/2024 6:30				
1/22/2024 6:40				
1/22/2024 6:50				
1/22/2024 7:00				
1/22/2024 7:10				

Site Time	Velocity A		Velocity B	
	Vel.x ft/s	Vel.y ft/s	Vel.x ft/s	Vel.y ft/s
America/Chicago				
1/22/2024 7:20				
1/22/2024 7:30				
1/22/2024 7:40				
1/22/2024 7:50				
1/22/2024 8:00				
1/22/2024 8:10				
1/22/2024 8:20				
1/22/2024 8:30				
1/22/2024 8:40				
1/22/2024 8:50				
1/22/2024 9:00				
1/22/2024 9:10				
1/22/2024 9:20				
1/22/2024 9:30				
1/22/2024 9:40				
1/22/2024 9:50				
1/22/2024 10:00				
1/22/2024 10:10				
1/22/2024 10:20				
1/22/2024 10:30				
1/22/2024 10:40				
1/22/2024 10:50				
1/22/2024 11:00				
1/22/2024 11:10				
1/22/2024 11:20				
1/22/2024 11:30				
1/22/2024 11:40				
1/22/2024 11:50				
1/22/2024 12:00				
1/22/2024 12:10				
1/22/2024 12:20				
1/22/2024 12:30				
1/22/2024 12:40				
1/22/2024 12:50				
1/22/2024 13:00				
1/22/2024 13:10				
1/22/2024 13:20				
1/22/2024 13:30				
1/22/2024 13:40				
1/22/2024 13:50				
1/22/2024 14:00				
1/22/2024 14:10				
1/22/2024 14:20				
1/22/2024 14:30				
1/22/2024 14:40				
1/22/2024 14:50				
1/22/2024 15:00				
1/22/2024 15:10				
1/22/2024 15:20				
1/22/2024 15:30				
1/22/2024 15:40				
1/22/2024 15:50				

Site Time	Velocity A		Velocity B	
	Vel.x ft/s	Vel.y ft/s	Vel.x ft/s	Vel.y ft/s
America/Chicago				
1/22/2024 16:00				
1/22/2024 16:10				
1/22/2024 16:20				
1/22/2024 16:30				
1/22/2024 16:40				
1/22/2024 16:50				
1/22/2024 17:00				
1/22/2024 17:10				
1/22/2024 17:20				
1/22/2024 17:30				
1/22/2024 17:40				
1/22/2024 17:50				
1/22/2024 18:00				
1/22/2024 18:10				
1/22/2024 18:20				
1/22/2024 18:30				
1/22/2024 18:40				
1/22/2024 18:50				
1/22/2024 19:00				
1/22/2024 19:10				
1/22/2024 19:20				
1/22/2024 19:30				
1/22/2024 19:40				
1/22/2024 19:50				
1/22/2024 20:00				
1/22/2024 20:10				
1/22/2024 20:20				
1/22/2024 20:30				
1/22/2024 20:40				
1/22/2024 20:50				
1/22/2024 21:00				
1/22/2024 21:10				
1/22/2024 21:20				
1/22/2024 21:30				
1/22/2024 21:40				
1/22/2024 21:50				
1/22/2024 22:00				
1/22/2024 22:10				
1/22/2024 22:20				
1/22/2024 22:30				
1/22/2024 22:40				
1/22/2024 22:50				
1/22/2024 23:00				
1/22/2024 23:10				
1/22/2024 23:20				
1/22/2024 23:30				
1/22/2024 23:40				
1/22/2024 23:50				
1/23/2024 0:00				
1/23/2024 0:10				
1/23/2024 0:20				
1/23/2024 0:30				

Site Time	Velocity A		Velocity B	
	Vel.x ft/s	Vel.y ft/s	Vel.x ft/s	Vel.y ft/s
America/Chicago				
1/23/2024 0:40				
1/23/2024 0:50				
1/23/2024 1:00				
1/23/2024 1:10				
1/23/2024 1:20				
1/23/2024 1:30				
1/23/2024 1:40				
1/23/2024 1:50				
1/23/2024 2:00				
1/23/2024 2:10				
1/23/2024 2:20				
1/23/2024 2:30				
1/23/2024 2:40				
1/23/2024 2:50				
1/23/2024 3:00				
1/23/2024 3:10				
1/23/2024 3:20				
1/23/2024 3:30				
1/23/2024 3:40				
1/23/2024 3:50				
1/23/2024 4:00				
1/23/2024 4:10				
1/23/2024 4:20				
1/23/2024 4:30				
1/23/2024 4:40				
1/23/2024 4:50				
1/23/2024 5:00				
1/23/2024 5:10				
1/23/2024 5:20				
1/23/2024 5:30				
1/23/2024 5:40				
1/23/2024 5:50				
1/23/2024 6:00				
1/23/2024 6:10				
1/23/2024 6:20				
1/23/2024 6:30				
1/23/2024 6:40				
1/23/2024 6:50				
1/23/2024 7:00				
1/23/2024 7:10				
1/23/2024 7:20				
1/23/2024 7:30				
1/23/2024 7:40				
1/23/2024 7:50				
1/23/2024 8:00				
1/23/2024 8:10				
1/23/2024 8:20				
1/23/2024 8:30				
1/23/2024 8:40				
1/23/2024 8:50				
1/23/2024 9:00				
1/23/2024 9:10				

Site Time	Velocity A		Velocity B	
	Vel.x ft/s	Vel.y ft/s	Vel.x ft/s	Vel.y ft/s
America/Chicago				
1/23/2024 9:20				
1/23/2024 9:30				
1/23/2024 9:40				
1/23/2024 9:50				
1/23/2024 10:00				
1/23/2024 10:10				
1/23/2024 10:20				
1/23/2024 10:30				
1/23/2024 10:40				
1/23/2024 10:50				
1/23/2024 11:00				
1/23/2024 11:10				
1/23/2024 11:20				
1/23/2024 11:30				
1/23/2024 11:40				
1/23/2024 11:50				
1/23/2024 12:00				
1/23/2024 12:10				
1/23/2024 12:20				
1/23/2024 12:30				
1/23/2024 12:40				
1/23/2024 12:50				
1/23/2024 13:00				
1/23/2024 13:10				
1/23/2024 13:20				
1/23/2024 13:30				
1/23/2024 13:40				
1/23/2024 13:50				
1/23/2024 14:00				
1/23/2024 14:10				
1/23/2024 14:20				
1/23/2024 14:30				
1/23/2024 14:40				
1/23/2024 14:50				
1/23/2024 15:00				
1/23/2024 15:10				
1/23/2024 15:20				
1/23/2024 15:30				
1/23/2024 15:40				
1/23/2024 15:50				
1/23/2024 16:00				
1/23/2024 16:10				
1/23/2024 16:20				
1/23/2024 16:30				
1/23/2024 16:40				
1/23/2024 16:50				
1/23/2024 17:00				
1/23/2024 17:10				
1/23/2024 17:20				
1/23/2024 17:30				
1/23/2024 17:40				
1/23/2024 17:50				

Site Time	Velocity A		Velocity B	
	Vel.x ft/s	Vel.y ft/s	Vel.x ft/s	Vel.y ft/s
America/Chicago				
1/23/2024 18:00				
1/23/2024 18:10				
1/23/2024 18:20				
1/23/2024 18:30				
1/23/2024 18:40				
1/23/2024 18:50				
1/23/2024 19:00				
1/23/2024 19:10				
1/23/2024 19:20				
1/23/2024 19:30				
1/23/2024 19:40				
1/23/2024 19:50				
1/23/2024 20:00				
1/23/2024 20:10				
1/23/2024 20:20				
1/23/2024 20:30				
1/23/2024 20:40				
1/23/2024 20:50				
1/23/2024 21:00				
1/23/2024 21:10				
1/23/2024 21:20				
1/23/2024 21:30				
1/23/2024 21:40				
1/23/2024 21:50				
1/23/2024 22:00				
1/23/2024 22:10				
1/23/2024 22:20				
1/23/2024 22:30				
1/23/2024 22:40				
1/23/2024 22:50				
1/23/2024 23:00				
1/23/2024 23:10				
1/23/2024 23:20				
1/23/2024 23:30				
1/23/2024 23:40				
1/23/2024 23:50				
1/24/2024 0:00				
1/24/2024 0:10				
1/24/2024 0:20				
1/24/2024 0:30				
1/24/2024 0:40				
1/24/2024 0:50				
1/24/2024 1:00				
1/24/2024 1:10				
1/24/2024 1:20				
1/24/2024 1:30				
1/24/2024 1:40				
1/24/2024 1:50				
1/24/2024 2:00				
1/24/2024 2:10				
1/24/2024 2:20				
1/24/2024 2:30				

Site Time	Velocity A		Velocity B	
	Vel.x ft/s	Vel.y ft/s	Vel.x ft/s	Vel.y ft/s
America/Chicago				
1/24/2024 2:40				
1/24/2024 2:50				
1/24/2024 3:00				
1/24/2024 3:10				
1/24/2024 3:20				
1/24/2024 3:30				
1/24/2024 3:40				
1/24/2024 3:50				
1/24/2024 4:00				
1/24/2024 4:10				
1/24/2024 4:20				
1/24/2024 4:30				
1/24/2024 4:40				
1/24/2024 4:50				
1/24/2024 5:00				
1/24/2024 5:10				
1/24/2024 5:20				
1/24/2024 5:30				
1/24/2024 5:40				
1/24/2024 5:50				
1/24/2024 6:00				
1/24/2024 6:10				
1/24/2024 6:20				
1/24/2024 6:30				
1/24/2024 6:40				
1/24/2024 6:50				
1/24/2024 7:00				
1/24/2024 7:10				
1/24/2024 7:20				
1/24/2024 7:30				
1/24/2024 7:40				
1/24/2024 7:50				
1/24/2024 8:00				
1/24/2024 8:10				
1/24/2024 8:20				
1/24/2024 8:30				
1/24/2024 8:40				
1/24/2024 8:50				
1/24/2024 9:00				
1/24/2024 9:10				
1/24/2024 9:20				
1/24/2024 9:30				
1/24/2024 9:40				
1/24/2024 9:50				
1/24/2024 10:00				
1/24/2024 10:10				
1/24/2024 10:20				
1/24/2024 10:30				
1/24/2024 10:40				
1/24/2024 10:50				
1/24/2024 11:00				
1/24/2024 11:10				

Site Time	Velocity A		Velocity B	
	Vel.x ft/s	Vel.y ft/s	Vel.x ft/s	Vel.y ft/s
America/Chicago				
1/24/2024 11:20				
1/24/2024 11:30				
1/24/2024 11:40				
1/24/2024 11:50				
1/24/2024 12:00				
1/24/2024 12:10				
1/24/2024 12:20				
1/24/2024 12:30				
1/24/2024 12:40				
1/24/2024 12:50				
1/24/2024 13:00				
1/24/2024 13:10				
1/24/2024 13:20				
1/24/2024 13:30				
1/24/2024 13:40				
1/24/2024 13:50				
1/24/2024 14:00				
1/24/2024 14:10				
1/24/2024 14:20				
1/24/2024 14:30				
1/24/2024 14:40				
1/24/2024 14:50				
1/24/2024 15:00				
1/24/2024 15:10				
1/24/2024 15:20				
1/24/2024 15:30				
1/24/2024 15:40				
1/24/2024 15:50				
1/24/2024 16:00				
1/24/2024 16:10				
1/24/2024 16:20				
1/24/2024 16:30				
1/24/2024 16:40				
1/24/2024 16:50				
1/24/2024 17:00				
1/24/2024 17:10				
1/24/2024 17:20				
1/24/2024 17:30				
1/24/2024 17:40				
1/24/2024 17:50				
1/24/2024 18:00				
1/24/2024 18:10				
1/24/2024 18:20				
1/24/2024 18:30				
1/24/2024 18:40				
1/24/2024 18:50				
1/24/2024 19:00				
1/24/2024 19:10				
1/24/2024 19:20				
1/24/2024 19:30				
1/24/2024 19:40				
1/24/2024 19:50				

Site Time	Velocity A		Velocity B	
	Vel.x ft/s	Vel.y ft/s	Vel.x ft/s	Vel.y ft/s
America/Chicago				
1/24/2024 20:00				
1/24/2024 20:10				
1/24/2024 20:20				
1/24/2024 20:30				
1/24/2024 20:40				
1/24/2024 20:50				
1/24/2024 21:00				
1/24/2024 21:10				
1/24/2024 21:20				
1/24/2024 21:30				
1/24/2024 21:40				
1/24/2024 21:50				
1/24/2024 22:00				
1/24/2024 22:10				
1/24/2024 22:20				
1/24/2024 22:30				
1/24/2024 22:40				
1/24/2024 22:50				
1/24/2024 23:00				
1/24/2024 23:10				
1/24/2024 23:20				
1/24/2024 23:30				
1/24/2024 23:40				
1/24/2024 23:50				
1/25/2024 0:00				
1/25/2024 0:10				
1/25/2024 0:20				
1/25/2024 0:30				
1/25/2024 0:40				
1/25/2024 0:50				
1/25/2024 1:00				
1/25/2024 1:10				
1/25/2024 1:20				
1/25/2024 1:30				
1/25/2024 1:40				
1/25/2024 1:50				
1/25/2024 2:00				
1/25/2024 2:10				
1/25/2024 2:20				
1/25/2024 2:30				
1/25/2024 2:40				
1/25/2024 2:50				
1/25/2024 3:00				
1/25/2024 3:10				
1/25/2024 3:20				
1/25/2024 3:30				
1/25/2024 3:40				
1/25/2024 3:50				
1/25/2024 4:00				
1/25/2024 4:10				
1/25/2024 4:20				
1/25/2024 4:30				

Site Time	Velocity A		Velocity B	
	Vel.x ft/s	Vel.y ft/s	Vel.x ft/s	Vel.y ft/s
America/Chicago				
1/25/2024 4:40				
1/25/2024 4:50				
1/25/2024 5:00				
1/25/2024 5:10				
1/25/2024 5:20				
1/25/2024 5:30				
1/25/2024 5:40				
1/25/2024 5:50				
1/25/2024 6:00				
1/25/2024 6:10				
1/25/2024 6:20				
1/25/2024 6:30				
1/25/2024 6:40				
1/25/2024 6:50				
1/25/2024 7:00				
1/25/2024 7:10				
1/25/2024 7:20				
1/25/2024 7:30				
1/25/2024 7:40				
1/25/2024 7:50				
1/25/2024 8:00				
1/25/2024 8:10				
1/25/2024 8:20				
1/25/2024 8:30				
1/25/2024 8:40				
1/25/2024 8:50				
1/25/2024 9:00				
1/25/2024 9:10				
1/25/2024 9:20				
1/25/2024 9:30				
1/25/2024 9:40				
1/25/2024 9:50				
1/25/2024 10:00				
1/25/2024 10:10				
1/25/2024 10:20				
1/25/2024 10:30				
1/25/2024 10:40				
1/25/2024 10:50				
1/25/2024 11:00				
1/25/2024 11:10				
1/25/2024 11:20				
1/25/2024 11:30				
1/25/2024 11:40				
1/25/2024 11:50				
1/25/2024 12:00				
1/25/2024 12:10				
1/25/2024 12:20				
1/25/2024 12:30				
1/25/2024 12:40				
1/25/2024 12:50				
1/25/2024 13:00				
1/25/2024 13:10				















Site Time	Velocity A		Velocity B		Site Time	Velocity A		Velocity B		Site Time	Velocity A		Velocity B		Site Time	Velocity A		Velocity B	
	Vel.x ft/s	Vel.y ft/s	Vel.x ft/s	Vel.y ft/s		Vel.x ft/s	Vel.y ft/s	Vel.x ft/s	Vel.y ft/s		Vel.x ft/s	Vel.y ft/s	Vel.x ft/s	Vel.y ft/s		Vel.x ft/s	Vel.y ft/s	Vel.x ft/s	Vel.y ft/s
America/Chicago					America/Chicago					America/Chicago					America/Chicago				
2/3/2024 21:20			0.4	-0.8	2/4/2024 6:00			0.4	-0.7	2/4/2024 14:40			0.3	-0.2	2/4/2024 23:20			0.3	-1
2/3/2024 21:30			0.2	-0.7	2/4/2024 6:10			0.3	-0.6	2/4/2024 14:50			0.1	-0.3	2/4/2024 23:30			0.2	-0.7
2/3/2024 21:40			0	-0.5	2/4/2024 6:20			0.4	-1.7	2/4/2024 15:00			0.5	-0.3	2/4/2024 23:40			0.2	-0.9
2/3/2024 21:50			0.3	-0.7	2/4/2024 6:30			0.3	-0.9	2/4/2024 15:10			0.1	-0.1	2/4/2024 23:50			0.1	-0.7
2/3/2024 22:00			0.2	-0.5	2/4/2024 6:40			0.1	-0.9	2/4/2024 15:20			0	-0.2	2/5/2024 0:00			0.3	-0.9
2/3/2024 22:10			0.2	-0.7	2/4/2024 6:50			0.6	-0.8	2/4/2024 15:30			0.2	-0.2	2/5/2024 0:10			0.1	-0.2
2/3/2024 22:20			0.4	-0.7	2/4/2024 7:00			0	-0.4	2/4/2024 15:40			0.5	-0.4	2/5/2024 0:20			0.4	-1
2/3/2024 22:30			0.2	-1	2/4/2024 7:10			0.6	-0.5	2/4/2024 15:50			0.2	-0.4	2/5/2024 0:30			0.1	-0.5
2/3/2024 22:40			0.5	-1	2/4/2024 7:20			0.1	-0.5	2/4/2024 16:00			0.3	-0.2	2/5/2024 0:40			0.1	-0.6
2/3/2024 22:50			0.4	-1	2/4/2024 7:30			0.9	-1.3	2/4/2024 16:10			0.2	-0.5	2/5/2024 0:50			0.2	-1.2
2/3/2024 23:00			0.5	-1.6	2/4/2024 7:40			0.3	-0.6	2/4/2024 16:20			0.2	-0.4	2/5/2024 1:00			0.3	-0.6
2/3/2024 23:10			0.2	-0.7	2/4/2024 7:50			0.6	-0.8	2/4/2024 16:30			0.3	-0.5	2/5/2024 1:10			0	-0.5
2/3/2024 23:20			0.5	-1.1	2/4/2024 8:00			0.2	-0.5	2/4/2024 16:40			0.3	-0.4	2/5/2024 1:20			0.3	-0.7
2/3/2024 23:30			-0.1	-0.5	2/4/2024 8:10			0.2	-0.4	2/4/2024 16:50			0.5	-1.3	2/5/2024 1:30			0.3	-0.6
2/3/2024 23:40			0.5	-1	2/4/2024 8:20			0.2	-0.4	2/4/2024 17:00			0.4	-0.6	2/5/2024 1:40			0.3	-0.6
2/3/2024 23:50			-0.4	-1.2	2/4/2024 8:30			-0.1	-0.4	2/4/2024 17:10			0.6	-1.1	2/5/2024 1:50			0.3	-0.9
2/4/2024 0:00			0.1	-1.4	2/4/2024 8:40			0	-0.8	2/4/2024 17:20			0.2	-0.9	2/5/2024 2:00			0.5	-0.5
2/4/2024 0:10			0.2	-0.5	2/4/2024 8:50			0.3	-0.3	2/4/2024 17:30			0.7	-0.8	2/5/2024 2:10			0.3	-0.5
2/4/2024 0:20			0.4	-0.5	2/4/2024 9:00			0.2	-0.3	2/4/2024 17:40			0.2	-0.6	2/5/2024 2:20			0.3	-0.5
2/4/2024 0:30			0.5	-0.7	2/4/2024 9:10			0.5	-1.2	2/4/2024 17:50			0.7	-1.1	2/5/2024 2:30			0.7	-1
2/4/2024 0:40			0.5	-1.9	2/4/2024 9:20			0.2	-0.6	2/4/2024 18:00			0.4	-0.5	2/5/2024 2:40			0.2	-0.7
2/4/2024 0:50			-0.4	-0.7	2/4/2024 9:30			0.2	-0.5	2/4/2024 18:10			0.4	-0.6	2/5/2024 2:50			0.3	-0.8
2/4/2024 1:00			1.1	-1.6	2/4/2024 9:40			0.4	-0.5	2/4/2024 18:20			0.3	-0.6	2/5/2024 3:00			0.2	-0.4
2/4/2024 1:10			0.1	-0.9	2/4/2024 9:50			0.1	-0.7	2/4/2024 18:30			0.3	-0.2	2/5/2024 3:10			0.5	-0.4
2/4/2024 1:20			0.2	-1	2/4/2024 10:00			0.5	-1.2	2/4/2024 18:40			0.4	-0.2	2/5/2024 3:20			0.3	-0.3
2/4/2024 1:30			-0.2	-0.9	2/4/2024 10:10			0.5	-0.1	2/4/2024 18:50			0.3	-0.8	2/5/2024 3:30			0.2	-0.5
2/4/2024 1:40			0.4	-0.4	2/4/2024 10:20			0.2	-0.6	2/4/2024 19:00			0.4	-0.5	2/5/2024 3:40			0.5	-0.5
2/4/2024 1:50			0	-0.9	2/4/2024 10:30			0.4	-0.8	2/4/2024 19:10			0.3	-0.7	2/5/2024 3:50			0.4	-0.6
2/4/2024 2:00			0.5	-0.6	2/4/2024 10:40			0.3	-0.5	2/4/2024 19:20			0.3	-0.6	2/5/2024 4:00			0.2	-0.5
2/4/2024 2:10			0.4	-0.6	2/4/2024 10:50			0.7	-1	2/4/2024 19:30			0.4	-0.1	2/5/2024 4:10			0.3	-0.7
2/4/2024 2:20			0.5	-0.9	2/4/2024 11:00			0.1	-0.6	2/4/2024 19:40			0.5	-0.5	2/5/2024 4:20			0.1	-0.3
2/4/2024 2:30			0.6	-1.1	2/4/2024 11:10			0.2	-0.5	2/4/2024 19:50			0.8	-1.3	2/5/2024 4:30			0.5	-0.5
2/4/2024 2:40			0.3	-1.5	2/4/2024 11:20			0.2	-0.5	2/4/2024 20:00			0.6	-1.2	2/5/2024 4:40			0.3	-0.6
2/4/2024 2:50			0.3	-0.9	2/4/2024 11:30			0.4	-0.5	2/4/2024 20:10			0.5	-0.9	2/5/2024 4:50			0.2	-0.8
2/4/2024 3:00			0.3	-0.4	2/4/2024 11:40			0.3	-0.3	2/4/2024 20:20			0.4	-0.8	2/5/2024 5:00			0.2	-0.4
2/4/2024 3:10			0.4	-0.8	2/4/2024 11:50			1.1	-0.3	2/4/2024 20:30			0.2	-0.8	2/5/2024 5:10			0.4	-0.4
2/4/2024 3:20			0.3	-0.3	2/4/2024 12:00			0.1	0	2/4/2024 20:40			0.1	-0.5	2/5/2024 5:20			0.1	-0.4
2/4/2024 3:30			0.4	-0.7	2/4/2024 12:10			0.6	-0.6	2/4/2024 20:50			0.3	-0.5	2/5/2024 5:30			0.5	-0.1
2/4/2024 3:40			0.6	-1.1	2/4/2024 12:20			0.5	-0.3	2/4/2024 21:00			0.3	-0.4	2/5/2024 5:40			0.1	-0.4
2/4/2024 3:50			0.2	-1.3	2/4/2024 12:30			0	0	2/4/2024 21:10			0.2	-0.3	2/5/2024 5:50			0.9	-0.3
2/4/2024 4:00			0.3	-0.4	2/4/2024 12:40			0.2	-0.1	2/4/2024 21:20			-0.1	-0.4	2/5/2024 6:00			0	0
2/4/2024 4:10			0.4	-0.9	2/4/2024 12:50			0.4	-0.2	2/4/2024 21:30			0.3	-0.6	2/5/2024 6:10			0	-0.4
2/4/2024 4:20			-0.2	-1.2	2/4/2024 13:00			0.1	-0.4	2/4/2024 21:40			0.5	-0.7	2/5/2024 6:20			0.2	-0.2
2/4/2024 4:30			0.5	-0.9	2/4/2024 13:10			0.1	-0.3	2/4/2024 21:50			0	-0.6	2/5/2024 6:30			0.2	-0.8
2/4/2024 4:40			0.4	-0.6	2/4/2024 13:20			0.1	-0.2	2/4/2024 22:00			0.6	-1.2	2/5/2024 6:40			0	-0.3
2/4/2024 4:50			0.4	-0.4	2/4/2024 13:30			0	0.2	2/4/2024 22:10			0	-0.6	2/5/2024 6:50			0.2	-0.1
2/4/2024 5:00			0.4	-0.4	2/4/2024 13:40			-0.1	0	2/4/2024 22:20			0.2	-1.2	2/5/2024 7:00			0.4	-0.3
2/4/2024 5:10			0.3	-0.6	2/4/2024 13:50			0.1	0.3	2/4/2024 22:30			0.4	-0.5	2/5/2024 7:10			0.5	-0.3
2/4/2024 5:20			0.4	-0.5	2/4/2024 14:00			0.2	-0.1	2/4/2024 22:40			0.1	-0.1	2/5/2024 7:20			0.5	0
2/4/2024 5:30			0.4	-0.7	2/4/2024 14:10			0.1	0.2	2/4/2024 22:50			0.1	-0.8	2/5/2024 7:30			0.6	-0.7
2/4/2024 5:40			0.3	-0.6	2/4/2024 14:20			0.6	0.3	2/4/2024 23:00			0.6	-0.5	2/5/2024 7:40			0.5	-0.3
2/4/2024 5:50			0.6	-0.5	2/4/2024 14:30			0.7	-0.7	2/4/2024 23:10			0.5	-1	2/5/2024 7:50			0.1	-0.3

























































































































Site Time	Velocity A		Velocity B	
	Vel.x ft/s	Vel.y ft/s	Vel.x ft/s	Vel.y ft/s
America/Chicago				
4/29/2024 21:20			1.3	-1.5
4/29/2024 21:30			1.4	-1.9
4/29/2024 21:40			2.5	-3.8
4/29/2024 21:50			1.3	-1.6
4/29/2024 22:00			1.5	-2.7
4/29/2024 22:10			0.3	-0.9
4/29/2024 22:20			1	-1.1
4/29/2024 22:30			1.5	-2.5
4/29/2024 22:40			0.9	-1.5
4/29/2024 22:50			1.1	-1.2
4/29/2024 23:00			0.8	-1.1
4/29/2024 23:10			1.6	-2.6
4/29/2024 23:20			1.5	-2.1
4/29/2024 23:30			0.7	-0.8
4/29/2024 23:40			0.1	-0.6
4/29/2024 23:50			1.2	-1.6
4/30/2024 0:00			0.4	-0.7
4/30/2024 0:10			0.5	-1.4
4/30/2024 0:20			0.8	-1.5
4/30/2024 0:30			0.5	-1.1
4/30/2024 0:40			0.2	-1.3
4/30/2024 0:50			-0.3	-0.1
4/30/2024 1:00			0.6	-1.6
4/30/2024 1:10			1.1	-1.8
4/30/2024 1:20			1.2	-1.6
4/30/2024 1:30			1.1	-1.7
4/30/2024 1:40			1.5	-1.8
4/30/2024 1:50			0.8	-1.2
4/30/2024 2:00			0.8	-1.4
4/30/2024 2:10			1	-1.8
4/30/2024 2:20			0.8	-1.1
4/30/2024 2:30			0.6	-0.9
4/30/2024 2:40			0.9	-1.3
4/30/2024 2:50			1	-1.2
4/30/2024 3:00			1.1	-1.8
4/30/2024 3:10			0.5	-0.8
4/30/2024 3:20			1.4	-1.7
4/30/2024 3:30			-0.2	-1.2
4/30/2024 3:40			1.6	-2.6
4/30/2024 3:50			0.2	-0.9
4/30/2024 4:00			0.3	-0.8
4/30/2024 4:10			0.1	-1.7
4/30/2024 4:20			0.3	-3.2
4/30/2024 4:30			0.6	-1
4/30/2024 4:40			1.3	-2.7
4/30/2024 4:50			0.6	-1.7
4/30/2024 5:00			0	-1.8
4/30/2024 5:10			0.5	-2.9
4/30/2024 5:20			-1.2	-1.4
4/30/2024 5:30			-1.5	-0.8
4/30/2024 5:40			-0.1	-1.3
4/30/2024 5:50			0.4	-1.4

Site Time	Velocity A		Velocity B	
	Vel.x ft/s	Vel.y ft/s	Vel.x ft/s	Vel.y ft/s
America/Chicago				
4/30/2024 6:00			0.1	-0.6
4/30/2024 6:10			-0.4	-0.5
4/30/2024 6:20			0.1	-1.7
4/30/2024 6:30			0.3	-2.1
4/30/2024 6:40			0.6	-1.5
4/30/2024 6:50			0.6	-2.5
4/30/2024 7:00			1.6	-1.8
4/30/2024 7:10			2.3	-2.4
4/30/2024 7:20			-0.1	-1.4
4/30/2024 7:30			0.1	-1.3
4/30/2024 7:40			0.8	-0.8
4/30/2024 7:50			0.5	-0.2
4/30/2024 8:00			0.7	-0.6
4/30/2024 8:10			0.3	-2.2
4/30/2024 8:20			0.7	-1.4
4/30/2024 8:30			0.2	-0.8
4/30/2024 8:40			0.1	-0.2
4/30/2024 8:50			0.7	-0.6
4/30/2024 9:00			0.4	-0.6
4/30/2024 9:10			1.6	-1.3
4/30/2024 9:20			-0.4	-0.8
4/30/2024 9:30			-0.7	-0.3
4/30/2024 9:40			0.4	-0.6
4/30/2024 9:50			1	-1.3
4/30/2024 10:00			0.6	-0.9
4/30/2024 10:10			0.4	-0.6
4/30/2024 10:20			1.3	-0.9
4/30/2024 10:30			0.1	-0.1
4/30/2024 10:40			2	-1.1
4/30/2024 10:50			0.2	0.1
4/30/2024 11:00			0.3	-0.1
4/30/2024 11:10			0.9	-1.1
4/30/2024 11:20			1.2	-1.7
4/30/2024 11:30			0.3	-0.8
4/30/2024 11:40			1.9	-1
4/30/2024 11:50			-1.6	0.4
4/30/2024 12:00			1.9	-1.9
4/30/2024 12:10			0.5	-1.1
4/30/2024 12:20			-0.6	-0.2
4/30/2024 12:30			-0.6	0.3
4/30/2024 12:40			0.2	-0.2
4/30/2024 12:50			0.3	-0.4
4/30/2024 13:00			1.1	-1.5
4/30/2024 13:10			-0.6	-0.3
4/30/2024 13:20			-0.9	-0.2
4/30/2024 13:30			-0.7	-0.3
4/30/2024 13:40			2.5	0.5
4/30/2024 13:50			0.3	0
4/30/2024 14:00			0.6	-0.4
4/30/2024 14:10			0.6	-0.5
4/30/2024 14:20			0.6	-0.6
4/30/2024 14:30			0.1	-0.4

Site Time	Velocity A		Velocity B	
	Vel.x ft/s	Vel.y ft/s	Vel.x ft/s	Vel.y ft/s
America/Chicago				
4/30/2024 14:40			1	-1.1
4/30/2024 14:50			1.7	-0.9
4/30/2024 15:00			-0.7	0.2
4/30/2024 15:10			-0.3	-0.2
4/30/2024 15:20			-0.8	-0.4
4/30/2024 15:30			0.5	-0.9
4/30/2024 15:40			0.7	-1.9
4/30/2024 15:50			1	-1.5
4/30/2024 16:00			0.8	-2.1
4/30/2024 16:10			1.7	-3.2
4/30/2024 16:20			0.5	-1.4
4/30/2024 16:30			0.9	-2.5
4/30/2024 16:40			-0.1	-2.2
4/30/2024 16:50			1	-1.3
4/30/2024 17:00			0.4	-0.9
4/30/2024 17:10			0.5	-1.7
4/30/2024 17:20			2.1	-3.3
4/30/2024 17:30			0.3	-0.9
4/30/2024 17:40			-0.5	0.7
4/30/2024 17:50			0	-0.8
4/30/2024 18:00			-0.5	-1
4/30/2024 18:10			2.8	-4.1
4/30/2024 18:20			0.7	-2
4/30/2024 18:30			0.6	-2.2
4/30/2024 18:40			-0.6	-0.9
4/30/2024 18:50			-0.1	0.3
4/30/2024 19:00			-0.1	-1.8
4/30/2024 19:10			0.7	0.2
4/30/2024 19:20			-0.8	-1.1
4/30/2024 19:30			1.1	-1.9
4/30/2024 19:40			0.1	0.2
4/30/2024 19:50			1.1	-1.5
4/30/2024 20:00			0.6	-2.3
4/30/2024 20:10			1.3	-2.6
4/30/2024 20:20			0.6	-1.4
4/30/2024 20:30			0.8	-1.4
4/30/2024 20:40			1.2	-1.7
4/30/2024 20:50			1	-1.2
4/30/2024 21:00			1.6	-3
4/30/2024 21:10			1.1	-2.4
4/30/2024 21:20			1.1	-1.6
4/30/2024 21:30			0.4	-0.5
4/30/2024 21:40			1.1	-1.7
4/30/2024 21:50			0.9	-1.8
4/30/2024 22:00			0.8	-1.5
4/30/2024 22:10			-0.2	-0.1
4/30/2024 22:20			1.1	-1.5
4/30/2024 22:30			1.9	-2.6
4/30/2024 22:40			0.6	-1.8
4/30/2024 22:50			0.7	-0.4
4/30/2024 23:00			1	-1.4
4/30/2024 23:10			1.3	-2.4

Site Time	Velocity A		Velocity B	
	Vel.x ft/s	Vel.y ft/s	Vel.x ft/s	Vel.y ft/s
America/Chicago				
4/30/2024 23:20			0.5	-0.4
4/30/2024 23:30			0.3	-0.2
4/30/2024 23:40			0.8	-1.2
4/30/2024 23:50			1.3	-1.8











































Site Time	Velocity A		Velocity B	
	Vel.x ft/s	Vel.y ft/s	Vel.x ft/s	Vel.y ft/s
America/Chicago				
5/31/2024 8:00			0.1	-0.5
5/31/2024 8:10			0.3	-0.4
5/31/2024 8:20			0.1	-0.5
5/31/2024 8:30			0.2	-0.5
5/31/2024 8:40			0.3	-0.4
5/31/2024 8:50			0.3	-0.5
5/31/2024 9:00			0.2	-0.4
5/31/2024 9:10			0.4	-0.5
5/31/2024 9:20			0.4	-0.3
5/31/2024 9:30			0.3	-0.7
5/31/2024 9:40			0.1	-0.4
5/31/2024 9:50			0.3	-0.5
5/31/2024 10:00			0.5	-0.6
5/31/2024 10:10			0.5	-0.6
5/31/2024 10:20			0.4	-0.7
5/31/2024 10:30			0.4	-0.4
5/31/2024 10:40			0.4	-0.6
5/31/2024 10:50			0.4	-0.4
5/31/2024 11:00			0.4	-0.5
5/31/2024 11:10			0.2	-0.3
5/31/2024 11:20			0.1	-0.3
5/31/2024 11:30			0.4	-0.5
5/31/2024 11:40			0.5	-0.5
5/31/2024 11:50			0.4	-0.4
5/31/2024 12:00			0.2	-0.7
5/31/2024 12:10			0.4	-0.4
5/31/2024 12:20			0.2	-0.2
5/31/2024 12:30			0.5	-0.9
5/31/2024 12:40			0.2	-0.5
5/31/2024 12:50			0.3	-0.4
5/31/2024 13:00			0.2	-0.5
5/31/2024 13:10			0.3	-0.4
5/31/2024 13:20			0.2	-0.5
5/31/2024 13:30			0.2	-0.3
5/31/2024 13:40			0.1	0
5/31/2024 13:50			0.1	-0.1
5/31/2024 14:00			0.3	-0.7
5/31/2024 14:10			0.2	-0.5
5/31/2024 14:20			0.4	-0.5
5/31/2024 14:30			0.4	-0.5
5/31/2024 14:40			0.4	-0.6
5/31/2024 14:50			0.3	-0.4
5/31/2024 15:00			0.2	-0.4
5/31/2024 15:10			0.3	-0.2
5/31/2024 15:20			0.2	-0.2
5/31/2024 15:30			0.3	-0.1
5/31/2024 15:40			0	0
5/31/2024 15:50			0	0.3
5/31/2024 16:00			-0.2	0.5
5/31/2024 16:10			-0.3	1.2
5/31/2024 16:20			-0.6	1.4
5/31/2024 16:30			-0.4	1.4

Site Time	Velocity A		Velocity B	
	Vel.x ft/s	Vel.y ft/s	Vel.x ft/s	Vel.y ft/s
America/Chicago				
5/31/2024 16:40			-0.4	1.3
5/31/2024 16:50			-0.3	1
5/31/2024 17:00			-0.1	0.5
5/31/2024 17:10			0.1	0
5/31/2024 17:20			0.1	0.1
5/31/2024 17:30			0.2	-0.2
5/31/2024 17:40			0.2	0
5/31/2024 17:50			-0.5	0.3
5/31/2024 18:00			-0.2	0.6
5/31/2024 18:10			-0.1	0.5
5/31/2024 18:20			-0.1	0
5/31/2024 18:30			0.1	-0.3
5/31/2024 18:40			0.3	-0.4
5/31/2024 18:50			0.3	-0.6
5/31/2024 19:00			0.3	-0.5
5/31/2024 19:10			0.3	-0.6
5/31/2024 19:20			0.7	-0.5
5/31/2024 19:30			0.5	-0.6
5/31/2024 19:40			0.3	-0.4
5/31/2024 19:50			0.4	-0.4
5/31/2024 20:00			0.3	-0.5
5/31/2024 20:10			0.1	-0.5
5/31/2024 20:20			0.3	-0.5
5/31/2024 20:30			0.1	-0.5
5/31/2024 20:40			0.5	-0.6
5/31/2024 20:50			0.4	-0.6
5/31/2024 21:00			0.5	-0.8
5/31/2024 21:10			0.5	-0.8
5/31/2024 21:20			0.6	-0.8
5/31/2024 21:30			0.5	-0.8
5/31/2024 21:40			0.3	-0.5
5/31/2024 21:50			0.4	-0.3
5/31/2024 22:00			0.5	-0.6
5/31/2024 22:10			0.3	-0.2
5/31/2024 22:20			0.2	-0.4
5/31/2024 22:30			0.3	-0.5
5/31/2024 22:40			0.1	-0.4
5/31/2024 22:50			0.2	-0.5
5/31/2024 23:00			0.5	-0.6
5/31/2024 23:10			0.4	-0.7
5/31/2024 23:20			0.2	-0.3
5/31/2024 23:30			0.4	-0.2
5/31/2024 23:40			0.1	0
5/31/2024 23:50			0.1	0

Site Time	Velocity A		Velocity B	
	Vel.x ft/s	Vel.y ft/s	Vel.x ft/s	Vel.y ft/s
America/Chicago				

Site Time	Velocity A		Velocity B	
	Vel.x ft/s	Vel.y ft/s	Vel.x ft/s	Vel.y ft/s
America/Chicago				

























































































Client IPC and MIMC Job Number 11215702 Sheet \_\_\_\_\_  
Project San Jacinto River Waste Pits Site Sheets By S.Chilka Date 11-22-2024  
Subject Wind and Wave Evaluation Checked By \_\_\_\_\_ Date \_\_\_\_\_

APPENDIX I - BMP STRUCTURAL DESIGN REPORT  
**ATTACHMENT 3.9**  
**WIND AND WAVE EVALUATION**

# Technical Memorandum

November 19, 2024

<b>To</b>	File	<b>Contact No.</b>	925 849 1019
<b>Copy to</b>	Lee Lavergne	<b>Email</b>	Satish.chilka@ghd.com
<b>From</b>	Mazen Idriss, EIT, Satish Chilka, PE	<b>Project No.</b>	11215702
<b>Project Name</b>	San Jacinto River Waste Pits SF - N		
<b>Subject</b>	Water Levels and Waves on Site		

## 1. Introduction

An engineered cofferdam using the best management practices (BMP) will encircle the Northern Impoundment of the San Jacinto River Waste Pits Superfund (Site) as shown in Figure 1. The BMP walls are designed for exposure to wind and varying water levels in the San Jacinto River in addition to other loads described in Section 3 (Appendix I). The top of the walls will be at elevation +10 ft (NAVD88). This memorandum evaluates the water levels in the river and wind-waves generated over the fetch area around the Site.



Figure 1 Northern Impoundment Vicinity Map

This Technical Memorandum is provided as an interim output under our agreement with IPC and MIMC. It is provided to foster discussion in relation to technical matters associated with the project and should not be relied upon in any way.

## 2. Water Levels

The Site is subject to tidal fluctuations, as well as increases in river level from rainfall and tropical storms. To evaluate these influences, the history of the water levels was hindcasted from an upriver USGS<sup>1</sup> gage near Sheldon, Texas. The details of the hindcast model and the determination of maximum water levels during the year are provided in the 100% Remedial Design (RD) report. The month-wise daily maximum water elevation from the hindcast model is reproduced in Figure 2. The maximum typical water levels on Site are lower than 3.75 ft and there are five (5) instances of water level higher than 10-ft that are outside the planned excavation period.

The sheet pile walls surrounding the excavation area at the Site are designed for different loading scenarios –

**Usual:** Service level loading experience frequently such as static earth pressures, hydrostatic pressures after installation of the BMP and during excavation.

**Unusual:** Loads larger than those considered Usual and experienced less frequently such as 100-year probability storm events and atypical water levels in the river.

**Extreme:** Worst case scenario loads, rarely experienced during the design life of the structure, such as hurricane level winds, flood levels in the river and barge impacts.

With an added factor of safety, the Usual loading scenarios are evaluated at water level of +5 ft (NAVD88) and the Unusual and Extreme loading scenarios are evaluated at water level of +10 ft (NAVD88) on Site. The interior side of the BMP is assumed to be dry i.e., free of standing water for all loading scenarios. As noted in Attachment 3.3 (Appendix I), it will take less than 2 hours to fill the excavation area in any of the excavation season. The water inside the excavation area will reduce the effective loading on the BMP walls as it will oppose the forces from the water in the river.

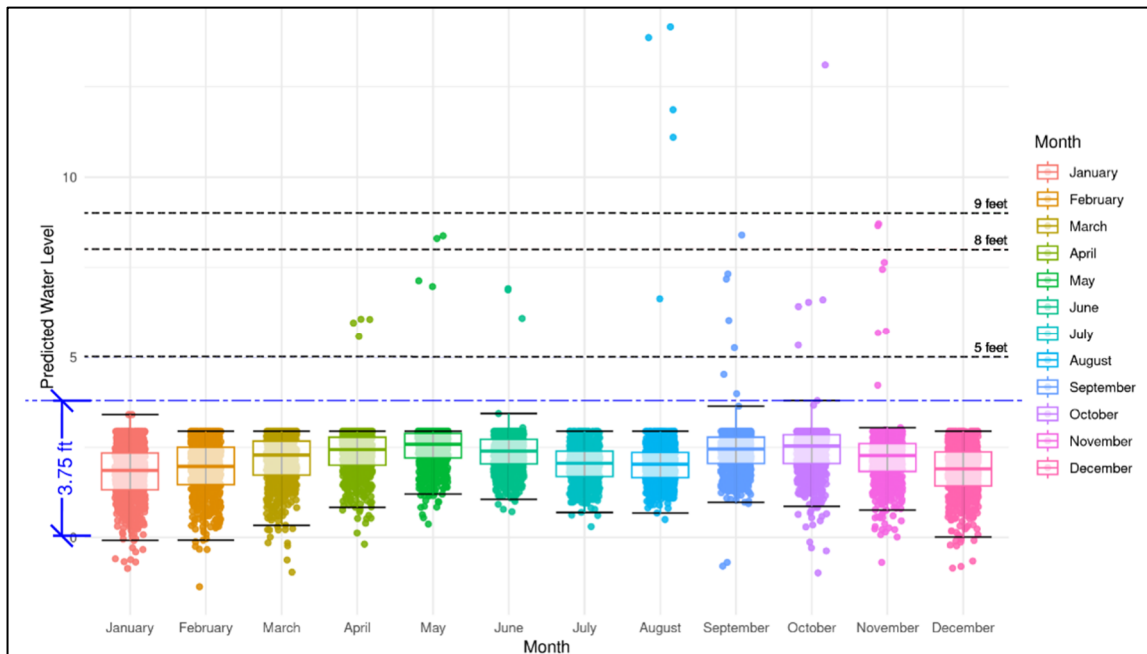

Figure 2 Month-wise Box Plots for Daily Maximum Elevations from Hindcast Model

<sup>1</sup> United States Geological Survey

This Technical Memorandum is provided as an interim output under our agreement with IPC and MIMC. It is provided to foster discussion in relation to technical matters associated with the project and should not be relied upon in any way other than the stated purpose.

### 3. Waves

Waves are generated by sustained winds over unobstructed open waters i.e., fetch area. The Site is sheltered by land on all sides within the 0.2 miles except the north and northwest directions as shown in Figure 3. There are barges moored on the north side within 0.3 miles interrupting the open waters and beyond that, the nearest land is 0.5 miles away. The unobstructed fetch distance to the northwest is less than 1.5 mile. For the waves to impact the sheet pile walls, winds have to blow toward the Site from approximately 300° to 60° direction relative to North).



Figure 3 Fetch Distance near Northern Impoundment

The wind data (3 sec gust) was obtained from Morgans Point, Texas (Station Number 8770613), located approximately 9 miles to southeast of the Site (Figure 4). The instrumentation on site is owned and operated by the Texas Coastal Ocean Observing Network. The anemometer is located approximately 25 feet above the mean sea level. Although wind data may be sensitive to local obstructions, the location provides the longest record of wind speed, direction, and water levels near the Site. Data record is available from January 1, 2001, to June 30, 2023, at 6-minute intervals. There are some interruptions in data continuity likely due to routine maintenance.

The distribution of the available wind speed and direction data is presented in the wind-rose diagram (Figure 5As shown in Figure 5 and Figure 6, there are only a few occurrences of significant wind speed events approaching from the north side of the Site. ). It shows that high winds typically approach the site from the south and southeast as expected for the tropical storm events. Less than 5% of the winds approach from the 300° to 60° direction.



**Figure 4** Location of Morgans Point, Texas (Station Number 8770613)

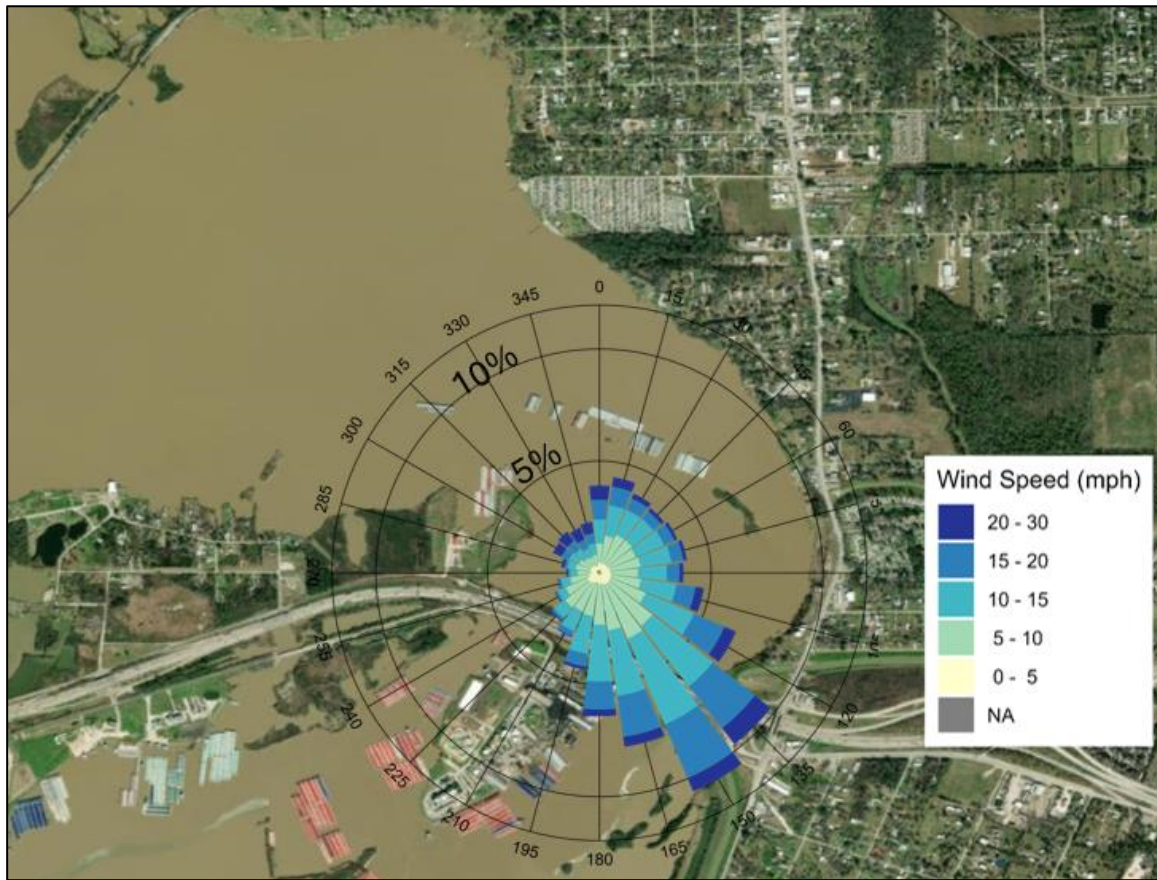

**Figure 5** Morgan's Point Wind Rose overlaid on Northern Impoundment

This Technical Memorandum is provided as an interim output under our agreement with IPC and MIMC. It is provided to foster discussion in relation to technical matters associated with the project and should not be relied upon in any way other than the stated purpose.

The data from Morgan's Point was filtered to include all instances where wind direction was recorded from 300° to 60° relative to North as shown in Figure 6. The maximum wind speed (3 sec gust) is approximately 79 mph with typical winds in the range of 25 to 35 mph. Although the station reported wind coming from the North, this instance coincided with Hurricane Ike, a category II event that made landfall to the South near Galveston, Texas on September 13, 2008. As the anemometer went offline after this date, it is inferred that the winds were a result of the hurricane passing through the site.

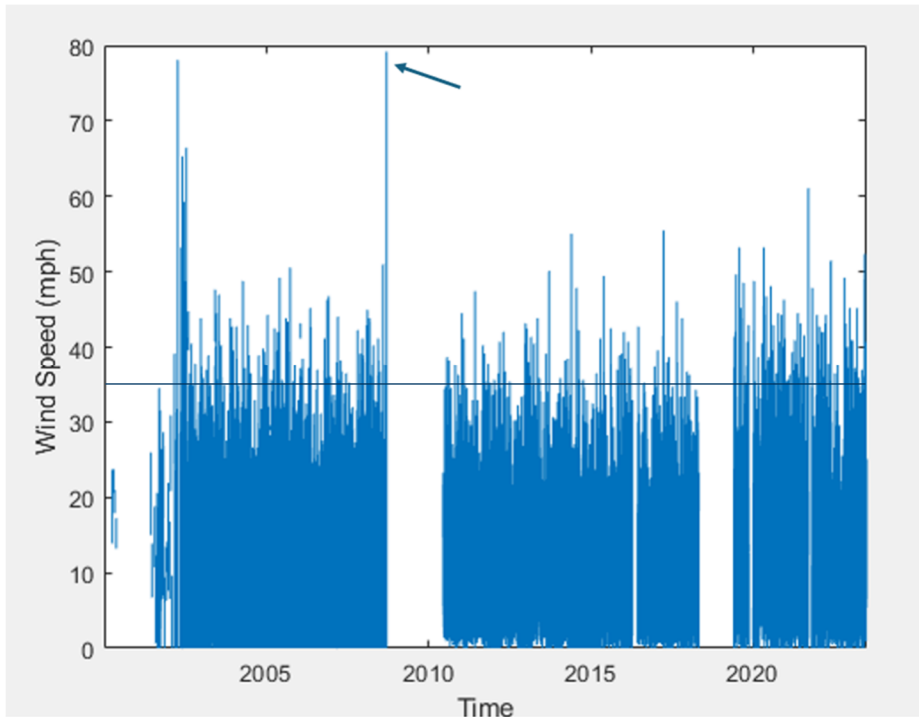

Figure 6 Morgan's Point Record for Wind (3 sec Gust) from 300° to 60°

The NOAA<sup>2</sup> navigation chart tool was used to estimate the average depth to mudline along the fetch. Approximately 50% of the length along the maximum fetch distance has depth less than 1 ft at normal river flow, with a narrow passage of deeper waters in the navigational channel as shown in Figure 7. The representative water depth is estimated as 10 ft at normal water levels (+2 ft) in the river for the purpose of the wave height calculation.

An estimate for wind wave heights was generated using the equations for fetch limited wave growth detailed in the CEM<sup>3</sup> assuming the winds are sustained for at least 1 hour over the fetch distance. The 3 sec gust of 79 mph equates to a 1-hour duration wind of 52.5 mph wind. Table 1 includes the wave heights calculated using the maximum wind speed in the direction of the maximum fetch distance of 1.3 miles. The wave heights were calculated for the normal water levels (+2 ft to +5 ft) in the river.

<sup>2</sup> National Oceanic and Atmospheric Administration

<sup>3</sup> Coastal Engineering Manual

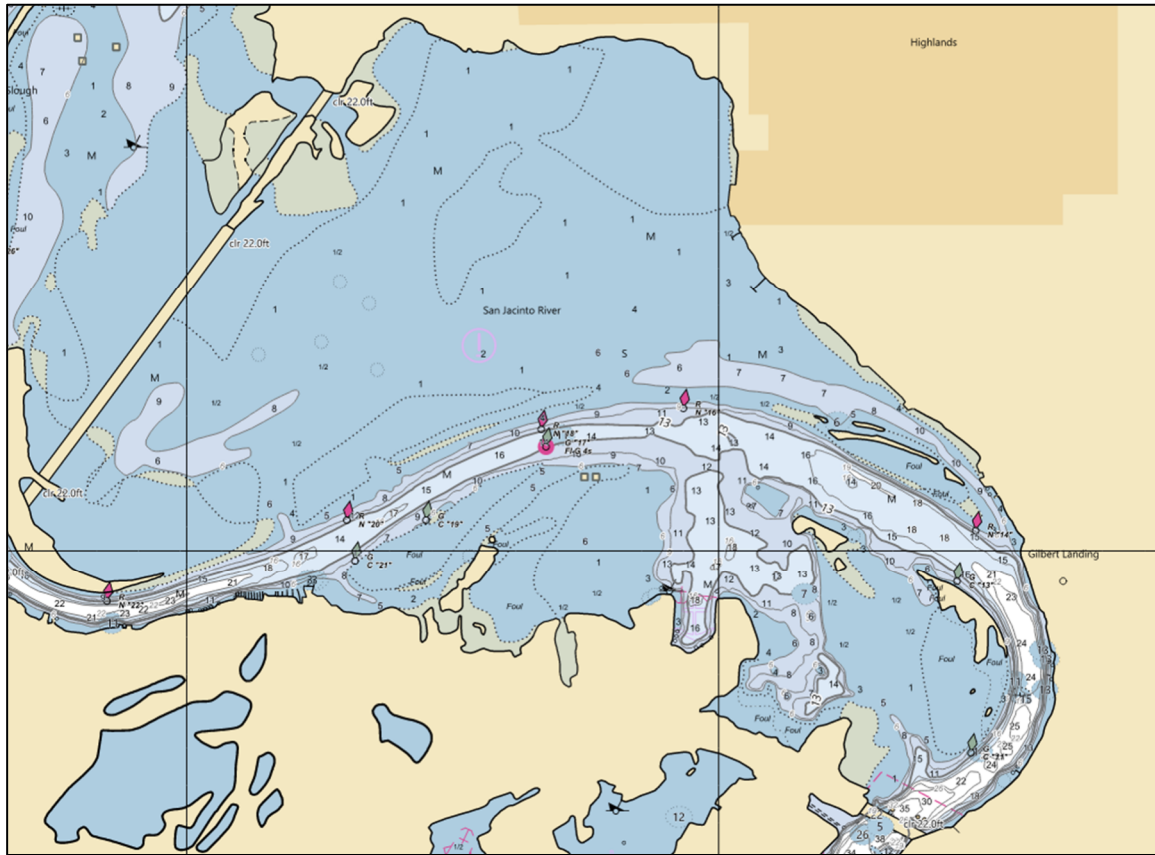

Figure 7 San Jacinto Riverbed Elevation – NOAA Navigation Chart

Table 1 Wave Height for Maximum Winds (1 hour) from North

Water Level (ft NAVD88)	Average Water Depth (ft)	Wind Wave Height (ft)	Peak Period (s)	Effective Water Surface Elevation (ft NAVD88)
2	10	0.85	2.63	2.85
3	11	0.85	2.64	3.85
4	12	0.85	2.65	4.85
5	13	0.86	2.65	5.85

The CEM also provides a threshold for breaking waves as the ratio between the water depth and the wave height. The waves break if this ratio is less than 1.28. This ratio is greater than 1.28 in each of the scenarios (water level and river depth) modeled therefore breaking waves are not expected near Site. As the nonbreaking waves do not trap an air pocket against the wall, the pressure at the wall has a gentle variation in time and is almost in phase with the wave elevation. Consequently, the wave load can be treated as a static load i.e., the effective water surface elevation can be considered as the sum of river water level and wave height for BMP wall design.

This Technical Memorandum is provided as an interim output under our agreement with IPC and MIMC. It is provided to foster discussion in relation to technical matters associated with the project and should not be relied upon in any way other than the stated purpose.

## 4. Wind and Water Levels

The time series for the maximum wind event used to calculate the wave heights is shown in Figure 8. The maximum value observed was a peak of 79 mph before the recording stopped on September 13<sup>th</sup>, 2008, as shown in the first plot. The corresponding water levels and wind directions are shown in the second and third plot respectively. There is some lag between the measured wind speed and the increase in the water levels at Morgan's Point. As the wind speed increased from 30 mph to 60 mph, between 2100 hrs (September 12) to 0300 (September 13), no increase in water level was measured at Morgan's Point for six (6) hours. The winds continued to increase and reached the peak measured value of 79 mph in the next 3 hours and the water levels increased the most in this duration (3 ft).

*It should be noted that these wind and water levels are specific to Morgan's Point station. The water levels are affected by the width of the channel, proximity to the ocean or tidal waters pushed upstream by the storm, and the surface runoff captured in the channel. The Northern Impoundment is likely more influenced by the surface runoff than the tidal waters influenced by the storm events. Also, as Lake Houston fills from the watershed, it can be expected that the increase in water levels near the Northern Impoundment will be related to the release of excess water from Lake Houston Dam.*

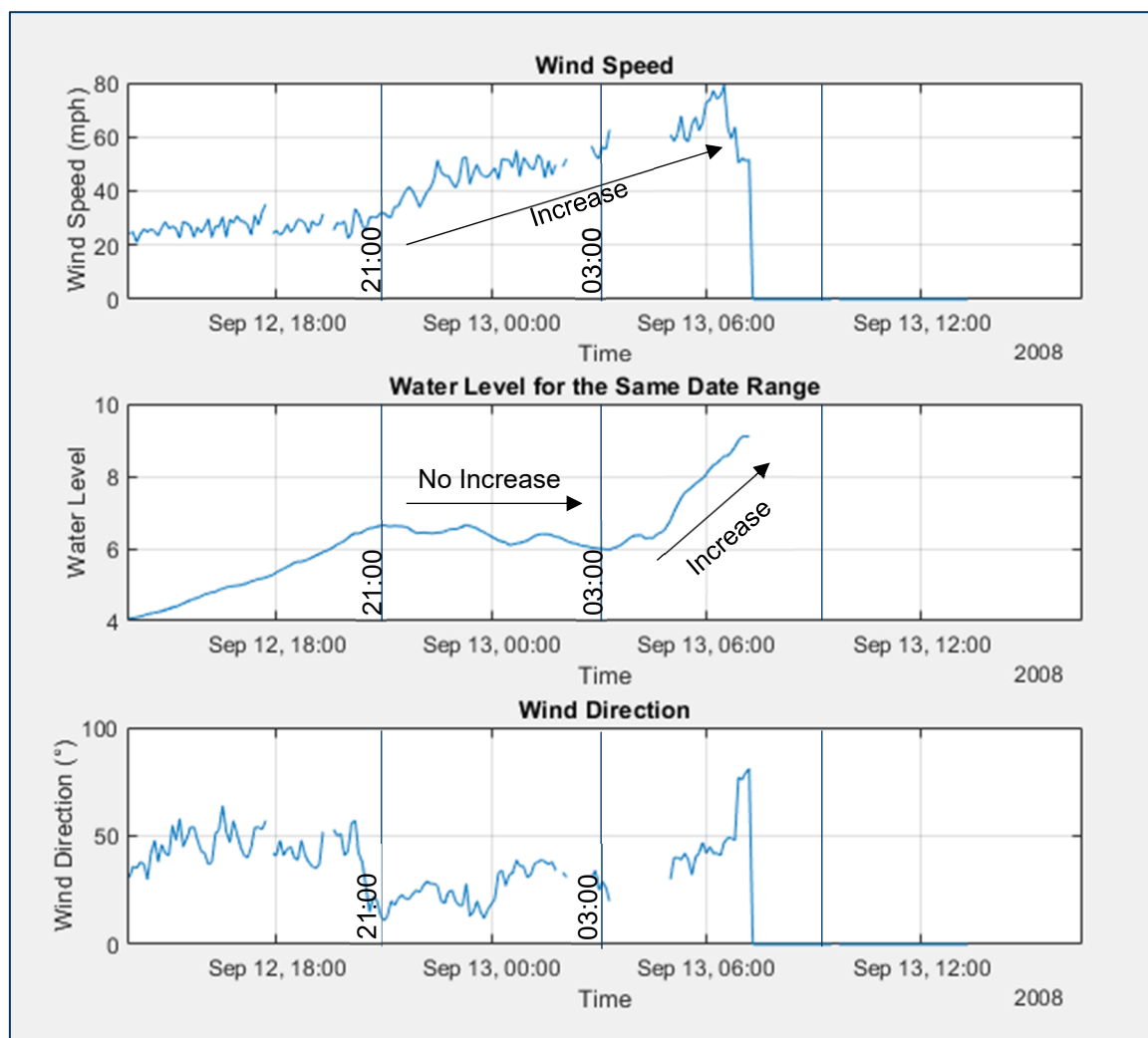

Figure 8 Time Series of Wind and Water on September 12-13, 2008.

This Technical Memorandum is provided as an interim output under our agreement with IPC and MIMC. It is provided to foster discussion in relation to technical matters associated with the project and should not be relied upon in any way other than the stated purpose.

## 5. Summary

As shown in Figure 5 and Figure 6, there are only a few occurrences of significant wind speed events approaching from the north side of the Site.

The maximum water surface elevation is +5.85 ft when significant winds approach over the maximum fetch distance near Site. The wave heights presented in Table 1 are calculated using a conservative approach by assuming the hurricane level wind (Extreme condition) is sustained over the maximum fetch available in a specific direction approaching the Site. Thus, it is noted that the waves will not affect the design or require a reevaluation for Usual load conditions.

For Unusual or Extreme load conditions, the BMP is designed with water level at top of the walls. Thus, a separate evaluation of wave loads on the BMP is not required.

The BMP walls are adequately designed to accommodate the effects of wind generated waves in the vicinity of the Northern Impoundment.





























































































































































































































































































































































































































































Date & Time	Water Level (ft)	Date & Time	Water Level (ft)	Date & Time	Water Level (ft)	Date & Time	Water Level (ft)	Date & Time	Water Level (ft)	Date & Time	Water Level (ft)	Date & Time	Water Level (ft)
11/1/2023 21:45	0.53	11/2/2023 10:45	1.72	11/2/2023 23:45	1.15	11/3/2023 12:45	1.01	11/4/2023 1:45	1.42	11/4/2023 14:45	1.07	11/5/2023 3:45	1.57
11/1/2023 22:00	0.61	11/2/2023 11:00	1.67	11/3/2023 0:00	1.23	11/3/2023 13:00	0.96	11/4/2023 2:00	1.49	11/4/2023 15:00	0.96	11/5/2023 4:00	1.61
11/1/2023 22:15	0.71	11/2/2023 11:15	1.62	11/3/2023 0:15	1.28	11/3/2023 13:15	0.91	11/4/2023 2:15	1.54	11/4/2023 15:15	0.98	11/5/2023 4:15	1.62
11/1/2023 22:30	0.79	11/2/2023 11:30	1.58	11/3/2023 0:30	1.35	11/3/2023 13:30	0.84	11/4/2023 2:30	1.61	11/4/2023 15:30	0.96	11/5/2023 4:30	1.64
11/1/2023 22:45	0.88	11/2/2023 11:45	1.49	11/3/2023 0:45	1.43	11/3/2023 13:45	0.83	11/4/2023 2:45	1.65	11/4/2023 15:45	0.86	11/5/2023 4:45	1.66
11/1/2023 23:00	0.96	11/2/2023 12:00	1.44	11/3/2023 1:00	1.48	11/3/2023 14:00	0.79	11/4/2023 3:00	1.69	11/4/2023 16:00	0.95	11/5/2023 5:00	1.69
11/1/2023 23:15	1.05	11/2/2023 12:15	1.38	11/3/2023 1:15	1.53	11/3/2023 14:15	0.75	11/4/2023 3:15	1.73	11/4/2023 16:15	0.86	11/5/2023 5:15	1.71
11/1/2023 23:30	1.14	11/2/2023 12:30	1.31	11/3/2023 1:30	1.57	11/3/2023 14:30	0.68	11/4/2023 3:30	1.75	11/4/2023 16:30	0.81	11/5/2023 5:30	1.68
11/1/2023 23:45	1.21	11/2/2023 12:45	1.25	11/3/2023 1:45	1.62	11/3/2023 14:45	0.66	11/4/2023 3:45	1.81	11/4/2023 16:45	0.75	11/5/2023 5:45	1.80
11/2/2023 0:00	1.28	11/2/2023 13:00	1.18	11/3/2023 2:00	1.64	11/3/2023 15:00	0.62	11/4/2023 4:00	1.84	11/4/2023 17:00	0.72	11/5/2023 6:00	1.72
11/2/2023 0:15	1.34	11/2/2023 13:15	1.11	11/3/2023 2:15	1.67	11/3/2023 15:15	0.65	11/4/2023 4:15	1.89	11/4/2023 17:15	0.69	11/5/2023 6:15	1.74
11/2/2023 0:30	1.40	11/2/2023 13:30	1.03	11/3/2023 2:30	1.70	11/3/2023 15:30	0.58	11/4/2023 4:30	1.90	11/4/2023 17:30	0.57	11/5/2023 6:30	1.75
11/2/2023 0:45	1.46	11/2/2023 13:45	0.97	11/3/2023 2:45	1.72	11/3/2023 15:45	0.51	11/4/2023 4:45	1.94	11/4/2023 17:45	0.57	11/5/2023 6:45	1.74
11/2/2023 1:00	1.49	11/2/2023 14:00	0.88	11/3/2023 3:00	1.74	11/3/2023 16:00	0.53	11/4/2023 5:00	1.95	11/4/2023 18:00	0.57	11/5/2023 7:00	1.76
11/2/2023 1:15	1.54	11/2/2023 14:15	0.82	11/3/2023 3:15	1.76	11/3/2023 16:15	0.48	11/4/2023 5:15	1.97	11/4/2023 18:15	0.56	11/5/2023 7:15	1.75
11/2/2023 1:30	1.58	11/2/2023 14:30	0.76	11/3/2023 3:30	1.79	11/3/2023 16:30	0.42	11/4/2023 5:30	1.99	11/4/2023 18:30	0.48	11/5/2023 7:30	1.74
11/2/2023 1:45	1.62	11/2/2023 14:45	0.73	11/3/2023 3:45	1.80	11/3/2023 16:45	0.46	11/4/2023 5:45	2.00	11/4/2023 18:45	0.44	11/5/2023 7:45	1.74
11/2/2023 2:00	1.64	11/2/2023 15:00	0.68	11/3/2023 4:00	1.81	11/3/2023 17:00	0.45	11/4/2023 6:00	2.01	11/4/2023 19:00	0.39	11/5/2023 8:00	1.75
11/2/2023 2:15	1.68	11/2/2023 15:15	0.58	11/3/2023 4:15	1.84	11/3/2023 17:15	0.38	11/4/2023 6:15	2.00	11/4/2023 19:15	0.38	11/5/2023 8:15	1.73
11/2/2023 2:30	1.72	11/2/2023 15:30	0.53	11/3/2023 4:30	1.86	11/3/2023 17:30	0.36	11/4/2023 6:30	2.06	11/4/2023 19:30	0.39	11/5/2023 8:30	1.67
11/2/2023 2:45	1.75	11/2/2023 15:45	0.45	11/3/2023 4:45	1.88	11/3/2023 17:45	0.36	11/4/2023 6:45	2.02	11/4/2023 19:45	0.31	11/5/2023 8:45	1.76
11/2/2023 3:00	1.74	11/2/2023 16:00	0.43	11/3/2023 5:00	1.89	11/3/2023 18:00	0.32	11/4/2023 7:00	2.05	11/4/2023 20:00	0.23	11/5/2023 9:00	1.73
11/2/2023 3:15	1.76	11/2/2023 16:15	0.38	11/3/2023 5:15	1.90	11/3/2023 18:15	0.23	11/4/2023 7:15	2.05	11/4/2023 20:15	0.25	11/5/2023 9:15	1.70
11/2/2023 3:30	1.77	11/2/2023 16:30	0.32	11/3/2023 5:30	1.91	11/3/2023 18:30	0.23	11/4/2023 7:30	2.05	11/4/2023 20:30	0.23	11/5/2023 9:30	1.66
11/2/2023 3:45	1.78	11/2/2023 16:45	0.31	11/3/2023 5:45	1.92	11/3/2023 18:45	0.20	11/4/2023 7:45	2.07	11/4/2023 20:45	0.19	11/5/2023 9:45	1.64
11/2/2023 4:00	1.82	11/2/2023 17:00	0.27	11/3/2023 6:00	1.91	11/3/2023 19:00	0.16	11/4/2023 8:00	2.03	11/4/2023 21:00	0.20	11/5/2023 10:00	1.63
11/2/2023 4:15	1.83	11/2/2023 17:15	0.26	11/3/2023 6:15	1.92	11/3/2023 19:15	0.11	11/4/2023 8:15	2.06	11/4/2023 21:15	0.20	11/5/2023 10:15	1.64
11/2/2023 4:30	1.83	11/2/2023 17:30	0.23	11/3/2023 6:30	1.92	11/3/2023 19:30	0.10	11/4/2023 8:30	2.03	11/4/2023 21:30	0.18	11/5/2023 10:30	1.60
11/2/2023 4:45	1.85	11/2/2023 17:45	0.21	11/3/2023 6:45	1.90	11/3/2023 19:45	0.09	11/4/2023 8:45	2.02	11/4/2023 21:45	0.17	11/5/2023 10:45	1.54
11/2/2023 5:00	1.84	11/2/2023 18:00	0.18	11/3/2023 7:00	1.90	11/3/2023 20:00	0.11	11/4/2023 9:00	2.00	11/4/2023 22:00	0.21	11/5/2023 11:00	1.56
11/2/2023 5:15	1.87	11/2/2023 18:15	0.17	11/3/2023 7:15	1.89	11/3/2023 20:15	0.08	11/4/2023 9:15	1.96	11/4/2023 22:15	0.25	11/5/2023 11:15	1.51
11/2/2023 5:30	1.87	11/2/2023 18:30	0.15	11/3/2023 7:30	1.88	11/3/2023 20:30	0.08	11/4/2023 9:30	1.95	11/4/2023 22:30	0.29	11/5/2023 11:30	1.49
11/2/2023 5:45	1.87	11/2/2023 18:45	0.16	11/3/2023 7:45	1.86	11/3/2023 20:45	0.09	11/4/2023 9:45	1.90	11/4/2023 22:45	0.33	11/5/2023 11:45	1.42
11/2/2023 6:00	1.88	11/2/2023 19:00	0.19	11/3/2023 8:00	1.86	11/3/2023 21:00	0.10	11/4/2023 10:00	1.85	11/4/2023 23:00	0.37	11/5/2023 12:00	1.41
11/2/2023 6:15	1.86	11/2/2023 19:15	0.18	11/3/2023 8:15	1.80	11/3/2023 21:15	0.13	11/4/2023 10:15	1.82	11/4/2023 23:15	0.41	11/5/2023 12:15	1.35
11/2/2023 6:30	1.85	11/2/2023 19:30	0.17	11/3/2023 8:30	1.77	11/3/2023 21:30	0.14	11/4/2023 10:30	1.78	11/4/2023 23:30	0.46	11/5/2023 12:30	1.36
11/2/2023 6:45	1.87	11/2/2023 19:45	0.20	11/3/2023 8:45	1.75	11/3/2023 21:45	0.19	11/4/2023 10:45	1.74	11/4/2023 23:45	0.56	11/5/2023 12:45	1.30
11/2/2023 7:00	1.90	11/2/2023 20:00	0.23	11/3/2023 9:00	1.72	11/3/2023 22:00	0.24	11/4/2023 11:00	1.75	11/5/2023 0:00	0.62	11/5/2023 13:00	1.26
11/2/2023 7:15	1.91	11/2/2023 20:15	0.26	11/3/2023 9:15	1.70	11/3/2023 22:15	0.31	11/4/2023 11:15	1.67	11/5/2023 0:15	0.71	11/5/2023 13:15	1.23
11/2/2023 7:30	1.92	11/2/2023 20:30	0.30	11/3/2023 9:30	1.64	11/3/2023 22:30	0.38	11/4/2023 11:30	1.66	11/5/2023 0:30	0.77	11/5/2023 13:30	1.14
11/2/2023 7:45	1.94	11/2/2023 20:45	0.35	11/3/2023 9:45	1.65	11/3/2023 22:45	0.46	11/4/2023 11:45	1.62	11/5/2023 0:45	0.83	11/5/2023 13:45	1.11
11/2/2023 8:00	1.90	11/2/2023 21:00	0.42	11/3/2023 10:00	1.58	11/3/2023 23:00	0.53	11/4/2023 12:00	1.54	11/5/2023 1:00	0.90	11/5/2023 14:00	1.10
11/2/2023 8:15	1.92	11/2/2023 21:15	0.47	11/3/2023 10:15	1.54	11/3/2023 23:15	0.62	11/4/2023 12:15	1.53	11/5/2023 1:15	0.99	11/5/2023 14:15	1.09
11/2/2023 8:30	1.88	11/2/2023 21:30	0.54	11/3/2023 10:30	1.49	11/3/2023 23:30	0.67	11/4/2023 12:30	1.44	11/5/2023 1:30	1.09	11/5/2023 14:30	1.02
11/2/2023 8:45	1.90	11/2/2023 21:45	0.60	11/3/2023 10:45	1.45	11/3/2023 23:45	0.75	11/4/2023 12:45	1.41	11/5/2023 1:45	1.14	11/5/2023 14:45	1.00
11/2/2023 9:00	1.90	11/2/2023 22:00	0.67	11/3/2023 11:00	1.41	11/4/2023 0:00	0.83	11/4/2023 13:00	1.35	11/5/2023 2:00	1.19	11/5/2023 15:00	0.98
11/2/2023 9:15	1.88	11/2/2023 22:15	0.74	11/3/2023 11:15	1.36	11/4/2023 0:15	0.92	11/4/2023 13:15	1.33	11/5/2023 2:15	1.28	11/5/2023 15:15	0.95
11/2/2023 9:30	1.87	11/2/2023 22:30	0.82	11/3/2023 11:30	1.29	11/4/2023 0:30	1.01	11/4/2023 13:30	1.32	11/5/2023 2:30	1.35	11/5/2023 15:30	0.92
11/2/2023 9:45	1.82	11/2/2023 22:45	0.88	11/3/2023 11:45	1.23	11/4/2023 0:45	1.10	11/4/2023 13:45	1.29	11/5/2023 2:45	1.42	11/5/2023 15:45	0.86
11/2/2023 10:00	1.85	11/2/2023 23:00	0.95	11/3/2023 12:00	1.18	11/4/2023 1:00	1.19	11/4/2023 14:00	1.17	11/5/2023 3:00	1.48	11/5/2023 16:00	0.85
11/2/2023 10:15	1.80	11/2/2023 23:15	1.02	11/3/2023 12:15	1.14	11/4/2023 1:15	1.27	11/4/2023 14:15	1.18	11/5/2023 3:15	1.50	11/5/2023 16:15	0.81
11/2/2023 10:30	1.76	11/2/2023 23:30	1.09	11/3/2023 12:30	1.07	11/4/2023 1:30	1.35	11/4/2023 14:30	1.10	11/5/2023 3:30	1.55	11/5/2023 16:30	0.88

Date & Time	Water Level (ft)	Date & Time	Water Level (ft)	Date & Time	Water Level (ft)	Date & Time	Water Level (ft)	Date & Time	Water Level (ft)	Date & Time	Water Level (ft)	Date & Time	Water Level (ft)
11/5/2023 16:45	0.81	11/6/2023 5:45	1.84	11/6/2023 18:45	0.84	11/7/2023 7:45	1.67	11/7/2023 20:45	0.86	11/8/2023 9:45	1.30	11/8/2023 22:45	1.00
11/5/2023 17:00	0.84	11/6/2023 6:00	1.82	11/6/2023 19:00	0.84	11/7/2023 8:00	1.67	11/7/2023 21:00	0.82	11/8/2023 10:00	1.29	11/8/2023 23:00	0.95
11/5/2023 17:15	0.74	11/6/2023 6:15	1.84	11/6/2023 19:15	0.79	11/7/2023 8:15	1.64	11/7/2023 21:15	0.69	11/8/2023 10:15	1.21	11/8/2023 23:15	0.92
11/5/2023 17:30	0.81	11/6/2023 6:30	1.84	11/6/2023 19:30	0.75	11/7/2023 8:30	1.63	11/7/2023 21:30	0.71	11/8/2023 10:30	1.20	11/8/2023 23:30	0.92
11/5/2023 17:45	0.68	11/6/2023 6:45	1.84	11/6/2023 19:45	0.73	11/7/2023 8:45	1.60	11/7/2023 21:45	0.69	11/8/2023 10:45	1.19	11/8/2023 23:45	0.87
11/5/2023 18:00	0.71	11/6/2023 7:00	1.85	11/6/2023 20:00	0.70	11/7/2023 9:00	1.58	11/7/2023 22:00	0.68	11/8/2023 11:00	1.17	11/9/2023 0:00	0.90
11/5/2023 18:15	0.72	11/6/2023 7:15	1.84	11/6/2023 20:15	0.65	11/7/2023 9:15	1.55	11/7/2023 22:15	0.66	11/8/2023 11:15	1.12	11/9/2023 0:15	0.85
11/5/2023 18:30	0.69	11/6/2023 7:30	1.82	11/6/2023 20:30	0.63	11/7/2023 9:30	1.45	11/7/2023 22:30	0.62	11/8/2023 11:30	1.12	11/9/2023 0:30	0.84
11/5/2023 18:45	0.64	11/6/2023 7:45	1.83	11/6/2023 20:45	0.56	11/7/2023 9:45	1.47	11/7/2023 22:45	0.59	11/8/2023 11:45	1.06	11/9/2023 0:45	0.85
11/5/2023 19:00	0.61	11/6/2023 8:00	1.81	11/6/2023 21:00	0.55	11/7/2023 10:00	1.42	11/7/2023 23:00	0.58	11/8/2023 12:00	1.06	11/9/2023 1:00	0.83
11/5/2023 19:15	0.58	11/6/2023 8:15	1.77	11/6/2023 21:15	0.51	11/7/2023 10:15	1.43	11/7/2023 23:15	0.52	11/8/2023 12:15	1.01	11/9/2023 1:15	0.84
11/5/2023 19:30	0.57	11/6/2023 8:30	1.78	11/6/2023 21:30	0.49	11/7/2023 10:30	1.37	11/7/2023 23:30	0.52	11/8/2023 12:30	0.97	11/9/2023 1:30	0.85
11/5/2023 19:45	0.56	11/6/2023 8:45	1.69	11/6/2023 21:45	0.50	11/7/2023 10:45	1.37	11/7/2023 23:45	0.46	11/8/2023 12:45	0.96	11/9/2023 1:45	0.86
11/5/2023 20:00	0.49	11/6/2023 9:00	1.69	11/6/2023 22:00	0.45	11/7/2023 11:00	1.27	11/8/2023 0:00	0.55	11/8/2023 13:00	0.95	11/9/2023 2:00	0.93
11/5/2023 20:15	0.51	11/6/2023 9:15	1.65	11/6/2023 22:15	0.49	11/7/2023 11:15	1.29	11/8/2023 0:15	0.49	11/8/2023 13:15	0.95	11/9/2023 2:15	0.95
11/5/2023 20:30	0.49	11/6/2023 9:30	1.65	11/6/2023 22:30	0.40	11/7/2023 11:30	1.27	11/8/2023 0:30	0.50	11/8/2023 13:30	0.91	11/9/2023 2:30	0.96
11/5/2023 20:45	0.47	11/6/2023 9:45	1.61	11/6/2023 22:45	0.41	11/7/2023 11:45	1.27	11/8/2023 0:45	0.59	11/8/2023 13:45	0.93	11/9/2023 2:45	1.03
11/5/2023 21:00	0.43	11/6/2023 10:00	1.61	11/6/2023 23:00	0.43	11/7/2023 12:00	1.23	11/8/2023 1:00	0.53	11/8/2023 14:00	0.91	11/9/2023 3:00	1.05
11/5/2023 21:15	0.36	11/6/2023 10:15	1.57	11/6/2023 23:15	0.40	11/7/2023 12:15	1.19	11/8/2023 1:15	0.55	11/8/2023 14:15	0.89	11/9/2023 3:15	1.10
11/5/2023 21:30	0.39	11/6/2023 10:30	1.50	11/6/2023 23:30	0.43	11/7/2023 12:30	1.12	11/8/2023 1:30	0.59	11/8/2023 14:30	0.87	11/9/2023 3:30	1.16
11/5/2023 21:45	0.36	11/6/2023 10:45	1.51	11/6/2023 23:45	0.43	11/7/2023 12:45	1.11	11/8/2023 1:45	0.66	11/8/2023 14:45	0.97	11/9/2023 3:45	1.21
11/5/2023 22:00	0.36	11/6/2023 11:00	1.45	11/7/2023 0:00	0.46	11/7/2023 13:00	1.08	11/8/2023 2:00	0.71	11/8/2023 15:00	0.95	11/9/2023 4:00	1.26
11/5/2023 22:15	0.41	11/6/2023 11:15	1.49	11/7/2023 0:15	0.48	11/7/2023 13:15	1.08	11/8/2023 2:15	0.76	11/8/2023 15:15	1.01	11/9/2023 4:15	1.32
11/5/2023 22:30	0.41	11/6/2023 11:30	1.42	11/7/2023 0:30	0.54	11/7/2023 13:30	1.05	11/8/2023 2:30	0.77	11/8/2023 15:30	1.03	11/9/2023 4:30	1.39
11/5/2023 22:45	0.43	11/6/2023 11:45	1.41	11/7/2023 0:45	0.60	11/7/2023 13:45	1.10	11/8/2023 2:45	0.89	11/8/2023 15:45	1.00	11/9/2023 4:45	1.41
11/5/2023 23:00	0.48	11/6/2023 12:00	1.34	11/7/2023 1:00	0.65	11/7/2023 14:00	1.05	11/8/2023 3:00	0.88	11/8/2023 16:00	1.00	11/9/2023 5:00	1.49
11/5/2023 23:15	0.51	11/6/2023 12:15	1.26	11/7/2023 1:15	0.72	11/7/2023 14:15	1.13	11/8/2023 3:15	0.94	11/8/2023 16:15	1.12	11/9/2023 5:15	1.53
11/5/2023 23:30	0.57	11/6/2023 12:30	1.31	11/7/2023 1:30	0.79	11/7/2023 14:30	1.17	11/8/2023 3:30	0.97	11/8/2023 16:30	1.09	11/9/2023 5:30	1.58
11/5/2023 23:45	0.60	11/6/2023 12:45	1.29	11/7/2023 1:45	0.86	11/7/2023 14:45	1.14	11/8/2023 3:45	1.06	11/8/2023 16:45	1.15	11/9/2023 5:45	1.62
11/6/2023 0:00	0.67	11/6/2023 13:00	1.20	11/7/2023 2:00	0.89	11/7/2023 15:00	1.07	11/8/2023 4:00	1.16	11/8/2023 17:00	1.22	11/9/2023 6:00	1.64
11/6/2023 0:15	0.74	11/6/2023 13:15	1.26	11/7/2023 2:15	0.99	11/7/2023 15:15	1.07	11/8/2023 4:15	1.17	11/8/2023 17:15	1.29	11/9/2023 6:15	1.67
11/6/2023 0:30	0.82	11/6/2023 13:30	1.13	11/7/2023 2:30	1.07	11/7/2023 15:30	1.09	11/8/2023 4:30	1.22	11/8/2023 17:30	1.28	11/9/2023 6:30	1.70
11/6/2023 0:45	0.90	11/6/2023 13:45	1.19	11/7/2023 2:45	1.09	11/7/2023 15:45	1.09	11/8/2023 4:45	1.29	11/8/2023 17:45	1.28	11/9/2023 6:45	1.70
11/6/2023 1:00	0.94	11/6/2023 14:00	1.19	11/7/2023 3:00	1.17	11/7/2023 16:00	1.14	11/8/2023 5:00	1.37	11/8/2023 18:00	1.35	11/9/2023 7:00	1.71
11/6/2023 1:15	1.03	11/6/2023 14:15	1.14	11/7/2023 3:15	1.25	11/7/2023 16:15	1.19	11/8/2023 5:15	1.48	11/8/2023 18:15	1.30	11/9/2023 7:15	1.70
11/6/2023 1:30	1.10	11/6/2023 14:30	1.18	11/7/2023 3:30	1.32	11/7/2023 16:30	1.22	11/8/2023 5:30	1.45	11/8/2023 18:30	1.40	11/9/2023 7:30	1.69
11/6/2023 1:45	1.18	11/6/2023 14:45	1.17	11/7/2023 3:45	1.37	11/7/2023 16:45	1.17	11/8/2023 5:45	1.44	11/8/2023 18:45	1.40	11/9/2023 7:45	1.68
11/6/2023 2:00	1.23	11/6/2023 15:00	1.10	11/7/2023 4:00	1.42	11/7/2023 17:00	1.24	11/8/2023 6:00	1.49	11/8/2023 19:00	1.38	11/9/2023 8:00	1.67
11/6/2023 2:15	1.30	11/6/2023 15:15	1.05	11/7/2023 4:15	1.51	11/7/2023 17:15	1.24	11/8/2023 6:15	1.48	11/8/2023 19:15	1.43	11/9/2023 8:15	1.64
11/6/2023 2:30	1.39	11/6/2023 15:30	1.12	11/7/2023 4:30	1.54	11/7/2023 17:30	1.17	11/8/2023 6:30	1.54	11/8/2023 19:30	1.40	11/9/2023 8:30	1.58
11/6/2023 2:45	1.42	11/6/2023 15:45	1.10	11/7/2023 4:45	1.59	11/7/2023 17:45	1.21	11/8/2023 6:45	1.53	11/8/2023 19:45	1.39	11/9/2023 8:45	1.57
11/6/2023 3:00	1.48	11/6/2023 16:00	1.08	11/7/2023 5:00	1.63	11/7/2023 18:00	1.12	11/8/2023 7:00	1.57	11/8/2023 20:00	1.42	11/9/2023 9:00	1.52
11/6/2023 3:15	1.56	11/6/2023 16:15	1.05	11/7/2023 5:15	1.63	11/7/2023 18:15	1.22	11/8/2023 7:15	1.51	11/8/2023 20:15	1.37	11/9/2023 9:15	1.48
11/6/2023 3:30	1.59	11/6/2023 16:30	1.07	11/7/2023 5:30	1.64	11/7/2023 18:30	1.11	11/8/2023 7:30	1.55	11/8/2023 20:30	1.32	11/9/2023 9:30	1.41
11/6/2023 3:45	1.66	11/6/2023 16:45	1.08	11/7/2023 5:45	1.65	11/7/2023 18:45	1.08	11/8/2023 7:45	1.52	11/8/2023 20:45	1.25	11/9/2023 9:45	1.40
11/6/2023 4:00	1.68	11/6/2023 17:00	1.06	11/7/2023 6:00	1.69	11/7/2023 19:00	1.06	11/8/2023 8:00	1.50	11/8/2023 21:00	1.24	11/9/2023 10:00	1.36
11/6/2023 4:15	1.72	11/6/2023 17:15	1.05	11/7/2023 6:15	1.67	11/7/2023 19:15	1.07	11/8/2023 8:15	1.47	11/8/2023 21:15	1.20	11/9/2023 10:15	1.31
11/6/2023 4:30	1.77	11/6/2023 17:30	1.00	11/7/2023 6:30	1.72	11/7/2023 19:30	1.12	11/8/2023 8:30	1.45	11/8/2023 21:30	1.18	11/9/2023 10:30	1.26
11/6/2023 4:45	1.79	11/6/2023 17:45	0.93	11/7/2023 6:45	1.70	11/7/2023 19:45	0.99	11/8/2023 8:45	1.38	11/8/2023 21:45	1.15	11/9/2023 10:45	1.24
11/6/2023 5:00	1.80	11/6/2023 18:00	0.94	11/7/2023 7:00	1.70	11/7/2023 20:00	0.89	11/8/2023 9:00	1.42	11/8/2023 22:00	1.11	11/9/2023 11:00	1.15
11/6/2023 5:15	1.81	11/6/2023 18:15	0.84	11/7/2023 7:15	1.70	11/7/2023 20:15	0.92	11/8/2023 9:15	1.37	11/8/2023 22:15	1.05	11/9/2023 11:15	1.12
11/6/2023 5:30	1.82	11/6/2023 18:30	0.87	11/7/2023 7:30	1.70	11/7/2023 20:30	0.89	11/8/2023 9:30	1.41	11/8/2023 22:30	0.98	11/9/2023 11:30	1.03











Date & Time	Water Level (ft)	Date & Time	Water Level (ft)	Date & Time	Water Level (ft)	Date & Time	Water Level (ft)	Date & Time	Water Level (ft)	Date & Time	Water Level (ft)	Date & Time	Water Level (ft)
11/28/2023 10:30	0.58	11/28/2023 23:30	1.31	11/29/2023 12:30	0.29	11/30/2023 1:30	1.73	11/30/2023 14:30	1.38	12/1/2023 3:30	2.91	12/1/2023 16:30	0.64
11/28/2023 10:45	0.53	11/28/2023 23:45	1.35	11/29/2023 12:45	0.25	11/30/2023 1:45	1.75	11/30/2023 14:45	1.44	12/1/2023 3:45	2.89	12/1/2023 16:45	0.57
11/28/2023 11:00	0.44	11/29/2023 0:00	1.37	11/29/2023 13:00	0.15	11/30/2023 2:00	1.80	11/30/2023 15:00	1.41	12/1/2023 4:00	2.89	12/1/2023 17:00	0.54
11/28/2023 11:15	0.37	11/29/2023 0:15	1.40	11/29/2023 13:15	0.08	11/30/2023 2:15	1.82	11/30/2023 15:15	1.45	12/1/2023 4:15	2.88	12/1/2023 17:15	0.54
11/28/2023 11:30	0.34	11/29/2023 0:30	1.41	11/29/2023 13:30	0.04	11/30/2023 2:30	1.79	11/30/2023 15:30	1.48	12/1/2023 4:30	2.79	12/1/2023 17:30	0.45
11/28/2023 11:45	0.31	11/29/2023 0:45	1.42	11/29/2023 13:45	0.00	11/30/2023 2:45	1.84	11/30/2023 15:45	1.58	12/1/2023 4:45	2.74	12/1/2023 17:45	0.41
11/28/2023 12:00	0.25	11/29/2023 1:00	1.43	11/29/2023 14:00	-0.05	11/30/2023 3:00	1.81	11/30/2023 16:00	1.66	12/1/2023 5:00	2.72	12/1/2023 18:00	0.40
11/28/2023 12:15	0.19	11/29/2023 1:15	1.42	11/29/2023 14:15	-0.10	11/30/2023 3:15	1.85	11/30/2023 16:15	1.75	12/1/2023 5:15	2.65	12/1/2023 18:15	0.39
11/28/2023 12:30	0.16	11/29/2023 1:30	1.45	11/29/2023 14:30	-0.14	11/30/2023 3:30	1.86	11/30/2023 16:30	1.73	12/1/2023 5:30	2.64	12/1/2023 18:30	0.40
11/28/2023 12:45	0.09	11/29/2023 1:45	1.40	11/29/2023 14:45	-0.15	11/30/2023 3:45	1.83	11/30/2023 16:45	1.80	12/1/2023 5:45	2.61	12/1/2023 18:45	0.33
11/28/2023 13:00	0.11	11/29/2023 2:00	1.43	11/29/2023 15:00	-0.17	11/30/2023 4:00	1.88	11/30/2023 17:00	1.80	12/1/2023 6:00	2.55	12/1/2023 19:00	0.32
11/28/2023 13:15	0.04	11/29/2023 2:15	1.39	11/29/2023 15:15	-0.18	11/30/2023 4:15	1.87	11/30/2023 17:15	1.68	12/1/2023 6:15	2.52	12/1/2023 19:15	0.37
11/28/2023 13:30	0.00	11/29/2023 2:30	1.42	11/29/2023 15:30	-0.19	11/30/2023 4:30	1.92	11/30/2023 17:30	1.71	12/1/2023 6:30	2.49	12/1/2023 19:30	0.32
11/28/2023 13:45	-0.06	11/29/2023 2:45	1.42	11/29/2023 15:45	-0.21	11/30/2023 4:45	1.99	11/30/2023 17:45	1.84	12/1/2023 6:45	2.45	12/1/2023 19:45	0.28
11/28/2023 14:00	-0.17	11/29/2023 3:00	1.41	11/29/2023 16:00	-0.29	11/30/2023 5:00	2.01	11/30/2023 18:00	1.99	12/1/2023 7:00	2.42	12/1/2023 20:00	0.27
11/28/2023 14:15	-0.22	11/29/2023 3:15	1.42	11/29/2023 16:15	-0.26	11/30/2023 5:15	1.98	11/30/2023 18:15	2.08	12/1/2023 7:15	2.40	12/1/2023 20:15	0.43
11/28/2023 14:30	-0.25	11/29/2023 3:30	1.41	11/29/2023 16:30	-0.32	11/30/2023 5:30	1.98	11/30/2023 18:30	2.11	12/1/2023 7:30	2.37	12/1/2023 20:30	0.33
11/28/2023 14:45	-0.29	11/29/2023 3:45	1.37	11/29/2023 16:45	-0.29	11/30/2023 5:45	2.02	11/30/2023 18:45	2.07	12/1/2023 7:45	2.35	12/1/2023 20:45	0.31
11/28/2023 15:00	-0.36	11/29/2023 4:00	1.40	11/29/2023 17:00	-0.31	11/30/2023 6:00	1.98	11/30/2023 19:00	1.91	12/1/2023 8:00	2.34	12/1/2023 21:00	0.38
11/28/2023 15:15	-0.35	11/29/2023 4:15	1.39	11/29/2023 17:15	-0.29	11/30/2023 6:15	2.01	11/30/2023 19:15	1.78	12/1/2023 8:15	2.29	12/1/2023 21:15	0.45
11/28/2023 15:30	-0.42	11/29/2023 4:30	1.38	11/29/2023 17:30	-0.25	11/30/2023 6:30	2.02	11/30/2023 19:30	1.73	12/1/2023 8:30	2.24	12/1/2023 21:30	0.50
11/28/2023 15:45	-0.41	11/29/2023 4:45	1.34	11/29/2023 17:45	-0.23	11/30/2023 6:45	2.12	11/30/2023 19:45	1.73	12/1/2023 8:45	2.18	12/1/2023 21:45	0.47
11/28/2023 16:00	-0.45	11/29/2023 5:00	1.40	11/29/2023 18:00	-0.20	11/30/2023 7:00	2.12	11/30/2023 20:00	1.78	12/1/2023 9:00	2.13	12/1/2023 22:00	0.55
11/28/2023 16:15	-0.45	11/29/2023 5:15	1.38	11/29/2023 18:15	-0.16	11/30/2023 7:15	2.18	11/30/2023 20:15	1.89	12/1/2023 9:15	2.10	12/1/2023 22:15	0.78
11/28/2023 16:30	-0.48	11/29/2023 5:30	1.36	11/29/2023 18:30	-0.09	11/30/2023 7:30	2.20	11/30/2023 20:30	2.01	12/1/2023 9:30	2.07	12/1/2023 22:30	0.81
11/28/2023 16:45	-0.49	11/29/2023 5:45	1.33	11/29/2023 18:45	-0.02	11/30/2023 7:45	2.22	11/30/2023 20:45	2.11	12/1/2023 9:45	2.02	12/1/2023 22:45	0.86
11/28/2023 17:00	-0.49	11/29/2023 6:00	1.35	11/29/2023 19:00	0.03	11/30/2023 8:00	2.25	11/30/2023 21:00	2.18	12/1/2023 10:00	2.01	12/1/2023 23:00	0.99
11/28/2023 17:15	-0.45	11/29/2023 6:15	1.34	11/29/2023 19:15	0.11	11/30/2023 8:15	2.16	11/30/2023 21:15	2.27	12/1/2023 10:15	1.99	12/1/2023 23:15	0.99
11/28/2023 17:30	-0.40	11/29/2023 6:30	1.33	11/29/2023 19:30	0.13	11/30/2023 8:30	2.11	11/30/2023 21:30	2.37	12/1/2023 10:30	1.96	12/1/2023 23:30	1.06
11/28/2023 17:45	-0.33	11/29/2023 6:45	1.31	11/29/2023 19:45	0.18	11/30/2023 8:45	2.10	11/30/2023 21:45	2.49	12/1/2023 10:45	1.92	12/1/2023 23:45	1.14
11/28/2023 18:00	-0.25	11/29/2023 7:00	1.29	11/29/2023 20:00	0.30	11/30/2023 9:00	2.15	11/30/2023 22:00	2.58	12/1/2023 11:00	1.85	12/2/2023 0:00	1.28
11/28/2023 18:15	-0.18	11/29/2023 7:15	1.27	11/29/2023 20:15	0.37	11/30/2023 9:15	2.08	11/30/2023 22:15	2.68	12/1/2023 11:15	1.79	12/2/2023 0:15	1.35
11/28/2023 18:30	-0.09	11/29/2023 7:30	1.24	11/29/2023 20:30	0.47	11/30/2023 9:30	2.10	11/30/2023 22:30	2.78	12/1/2023 11:30	1.74	12/2/2023 0:30	1.38
11/28/2023 18:45	0.00	11/29/2023 7:45	1.20	11/29/2023 20:45	0.59	11/30/2023 9:45	1.99	11/30/2023 22:45	2.85	12/1/2023 11:45	1.69	12/2/2023 0:45	1.51
11/28/2023 19:00	0.06	11/29/2023 8:00	1.15	11/29/2023 21:00	0.67	11/30/2023 10:00	1.94	11/30/2023 23:00	2.92	12/1/2023 12:00	1.62	12/2/2023 1:00	1.55
11/28/2023 19:15	0.15	11/29/2023 8:15	1.16	11/29/2023 21:15	0.74	11/30/2023 10:15	1.97	11/30/2023 23:15	3.00	12/1/2023 12:15	1.57	12/2/2023 1:15	1.62
11/28/2023 19:30	0.28	11/29/2023 8:30	1.08	11/29/2023 21:30	0.84	11/30/2023 10:30	1.89	11/30/2023 23:30	3.09	12/1/2023 12:30	1.49	12/2/2023 1:30	1.67
11/28/2023 19:45	0.32	11/29/2023 8:45	1.08	11/29/2023 21:45	0.93	11/30/2023 10:45	1.73	11/30/2023 23:45	3.10	12/1/2023 12:45	1.45	12/2/2023 1:45	1.68
11/28/2023 20:00	0.41	11/29/2023 9:00	1.02	11/29/2023 22:00	1.01	11/30/2023 11:00	1.79	12/1/2023 0:00	3.13	12/1/2023 13:00	1.41	12/2/2023 2:00	1.68
11/28/2023 20:15	0.52	11/29/2023 9:15	1.00	11/29/2023 22:15	1.13	11/30/2023 11:15	1.75	12/1/2023 0:15	3.16	12/1/2023 13:15	1.33	12/2/2023 2:15	1.71
11/28/2023 20:30	0.58	11/29/2023 9:30	0.94	11/29/2023 22:30	1.14	11/30/2023 11:30	1.78	12/1/2023 0:30	3.14	12/1/2023 13:30	1.28	12/2/2023 2:30	1.79
11/28/2023 20:45	0.70	11/29/2023 9:45	0.91	11/29/2023 22:45	1.27	11/30/2023 11:45	1.69	12/1/2023 0:45	3.14	12/1/2023 13:45	1.24	12/2/2023 2:45	1.75
11/28/2023 21:00	0.76	11/29/2023 10:00	0.81	11/29/2023 23:00	1.31	11/30/2023 12:00	1.62	12/1/2023 1:00	3.13	12/1/2023 14:00	1.20	12/2/2023 3:00	1.84
11/28/2023 21:15	0.85	11/29/2023 10:15	0.77	11/29/2023 23:15	1.36	11/30/2023 12:15	1.63	12/1/2023 1:15	3.15	12/1/2023 14:15	1.09	12/2/2023 3:15	1.85
11/28/2023 21:30	0.95	11/29/2023 10:30	0.76	11/29/2023 23:30	1.41	11/30/2023 12:30	1.49	12/1/2023 1:30	3.11	12/1/2023 14:30	1.05	12/2/2023 3:30	1.80
11/28/2023 21:45	1.02	11/29/2023 10:45	0.67	11/29/2023 23:45	1.47	11/30/2023 12:45	1.41	12/1/2023 1:45	3.11	12/1/2023 14:45	1.04	12/2/2023 3:45	1.81
11/28/2023 22:00	1.10	11/29/2023 11:00	0.63	11/30/2023 0:00	1.50	11/30/2023 13:00	1.42	12/1/2023 2:00	3.09	12/1/2023 15:00	0.87	12/2/2023 4:00	1.86
11/28/2023 22:15	1.15	11/29/2023 11:15	0.59	11/30/2023 0:15	1.54	11/30/2023 13:15	1.41	12/1/2023 2:15	3.04	12/1/2023 15:15	0.94	12/2/2023 4:15	1.88
11/28/2023 22:30	1.20	11/29/2023 11:30	0.51	11/30/2023 0:30	1.61	11/30/2023 13:30	1.41	12/1/2023 2:30	3.06	12/1/2023 15:30	0.79	12/2/2023 4:30	1.85
11/28/2023 22:45	1.23	11/29/2023 11:45	0.44	11/30/2023 0:45	1.62	11/30/2023 13:45	1.37	12/1/2023 2:45	3.06	12/1/2023 15:45	0.74	12/2/2023 4:45	1.80
11/28/2023 23:00	1.26	11/29/2023 12:00	0.41	11/30/2023 1:00	1.65	11/30/2023 14:00	1.36	12/1/2023 3:00	3.02	12/1/2023 16:00	0.76	12/2/2023 5:00	1.77
11/28/2023 23:15	1.30	11/29/2023 12:15	0.39	11/30/2023 1:15	1.71	11/30/2023 14:15	1.30	12/1/2023 3:15	2.91	12/1/2023 16:15	0.67	12/2/2023 5:15	1.66

Date & Time	Water Level (ft)	Date & Time	Water Level (ft)	Date & Time	Water Level (ft)	Date & Time	Water Level (ft)	Date & Time	Water Level (ft)	Date & Time	Water Level (ft)	Date & Time	Water Level (ft)
12/2/2023 5:30	1.63	12/2/2023 18:30	0.07	12/3/2023 7:30	1.39	12/3/2023 20:30	-0.21	12/4/2023 9:30	0.76	12/4/2023 22:30	-0.06	12/5/2023 11:30	0.32
12/2/2023 5:45	1.65	12/2/2023 18:45	0.06	12/3/2023 7:45	1.38	12/3/2023 20:45	-0.20	12/4/2023 9:45	0.70	12/4/2023 22:45	-0.03	12/5/2023 11:45	0.30
12/2/2023 6:00	1.58	12/2/2023 19:00	0.08	12/3/2023 8:00	1.34	12/3/2023 21:00	-0.14	12/4/2023 10:00	0.72	12/4/2023 23:00	0.00	12/5/2023 12:00	0.26
12/2/2023 6:15	1.68	12/2/2023 19:15	0.07	12/3/2023 8:15	1.32	12/3/2023 21:15	-0.12	12/4/2023 10:15	0.59	12/4/2023 23:15	0.10	12/5/2023 12:15	0.25
12/2/2023 6:30	1.59	12/2/2023 19:30	0.07	12/3/2023 8:30	1.28	12/3/2023 21:30	-0.08	12/4/2023 10:30	0.63	12/4/2023 23:30	0.16	12/5/2023 12:30	0.24
12/2/2023 6:45	1.57	12/2/2023 19:45	0.09	12/3/2023 8:45	1.28	12/3/2023 21:45	-0.06	12/4/2023 10:45	0.55	12/4/2023 23:45	0.22	12/5/2023 12:45	0.20
12/2/2023 7:00	1.57	12/2/2023 20:00	0.12	12/3/2023 9:00	1.25	12/3/2023 22:00	0.00	12/4/2023 11:00	0.54	12/5/2023 0:00	0.28	12/5/2023 13:00	0.23
12/2/2023 7:15	1.52	12/2/2023 20:15	0.20	12/3/2023 9:15	1.24	12/3/2023 22:15	0.04	12/4/2023 11:15	0.56	12/5/2023 0:15	0.36	12/5/2023 13:15	0.18
12/2/2023 7:30	1.53	12/2/2023 20:30	0.23	12/3/2023 9:30	1.14	12/3/2023 22:30	0.12	12/4/2023 11:30	0.52	12/5/2023 0:30	0.41	12/5/2023 13:30	0.19
12/2/2023 7:45	1.46	12/2/2023 20:45	0.24	12/3/2023 9:45	1.16	12/3/2023 22:45	0.18	12/4/2023 11:45	0.47	12/5/2023 0:45	0.45	12/5/2023 13:45	0.15
12/2/2023 8:00	1.43	12/2/2023 21:00	0.31	12/3/2023 10:00	0.95	12/3/2023 23:00	0.26	12/4/2023 12:00	0.50	12/5/2023 1:00	0.57	12/5/2023 14:00	0.12
12/2/2023 8:15	1.36	12/2/2023 21:15	0.34	12/3/2023 10:15	0.98	12/3/2023 23:15	0.29	12/4/2023 12:15	0.49	12/5/2023 1:15	0.56	12/5/2023 14:15	0.18
12/2/2023 8:30	1.43	12/2/2023 21:30	0.46	12/3/2023 10:30	0.97	12/3/2023 23:30	0.38	12/4/2023 12:30	0.57	12/5/2023 1:30	0.63	12/5/2023 14:30	0.21
12/2/2023 8:45	1.34	12/2/2023 21:45	0.53	12/3/2023 10:45	0.92	12/3/2023 23:45	0.49	12/4/2023 12:45	0.53	12/5/2023 1:45	0.71	12/5/2023 14:45	0.17
12/2/2023 9:00	1.39	12/2/2023 22:00	0.57	12/3/2023 11:00	0.91	12/4/2023 0:00	0.55	12/4/2023 13:00	0.43	12/5/2023 2:00	0.75	12/5/2023 15:00	0.16
12/2/2023 9:15	1.34	12/2/2023 22:15	0.62	12/3/2023 11:15	0.82	12/4/2023 0:15	0.62	12/4/2023 13:15	0.40	12/5/2023 2:15	0.84	12/5/2023 15:15	0.16
12/2/2023 9:30	1.32	12/2/2023 22:30	0.67	12/3/2023 11:30	0.77	12/4/2023 0:30	0.69	12/4/2023 13:30	0.41	12/5/2023 2:30	0.89	12/5/2023 15:30	0.19
12/2/2023 9:45	1.33	12/2/2023 22:45	0.78	12/3/2023 11:45	0.75	12/4/2023 0:45	0.73	12/4/2023 13:45	0.36	12/5/2023 2:45	0.91	12/5/2023 15:45	0.15
12/2/2023 10:00	1.32	12/2/2023 23:00	0.84	12/3/2023 12:00	0.69	12/4/2023 1:00	0.79	12/4/2023 14:00	0.26	12/5/2023 3:00	0.93	12/5/2023 16:00	0.17
12/2/2023 10:15	1.25	12/2/2023 23:15	0.91	12/3/2023 12:15	0.66	12/4/2023 1:15	0.88	12/4/2023 14:15	0.33	12/5/2023 3:15	0.99	12/5/2023 16:15	0.20
12/2/2023 10:30	1.17	12/2/2023 23:30	1.00	12/3/2023 12:30	0.63	12/4/2023 1:30	0.92	12/4/2023 14:30	0.27	12/5/2023 3:30	0.99	12/5/2023 16:30	0.20
12/2/2023 10:45	1.12	12/2/2023 23:45	1.05	12/3/2023 12:45	0.59	12/4/2023 1:45	1.00	12/4/2023 14:45	0.28	12/5/2023 3:45	1.01	12/5/2023 16:45	0.17
12/2/2023 11:00	1.13	12/3/2023 0:00	1.13	12/3/2023 13:00	0.57	12/4/2023 2:00	1.04	12/4/2023 15:00	0.17	12/5/2023 4:00	1.03	12/5/2023 17:00	0.16
12/2/2023 11:15	1.12	12/3/2023 0:15	1.24	12/3/2023 13:15	0.51	12/4/2023 2:15	1.04	12/4/2023 15:15	0.18	12/5/2023 4:15	1.02	12/5/2023 17:15	0.18
12/2/2023 11:30	1.09	12/3/2023 0:30	1.18	12/3/2023 13:30	0.52	12/4/2023 2:30	1.11	12/4/2023 15:30	0.12	12/5/2023 4:30	1.03	12/5/2023 17:30	0.18
12/2/2023 11:45	1.02	12/3/2023 0:45	1.39	12/3/2023 13:45	0.48	12/4/2023 2:45	1.15	12/4/2023 15:45	0.19	12/5/2023 4:45	1.03	12/5/2023 17:45	0.22
12/2/2023 12:00	1.02	12/3/2023 1:00	1.50	12/3/2023 14:00	0.46	12/4/2023 3:00	1.24	12/4/2023 16:00	0.09	12/5/2023 5:00	1.04	12/5/2023 18:00	0.22
12/2/2023 12:15	1.00	12/3/2023 1:15	1.43	12/3/2023 14:15	0.40	12/4/2023 3:15	1.26	12/4/2023 16:15	0.07	12/5/2023 5:15	1.04	12/5/2023 18:15	0.21
12/2/2023 12:30	0.90	12/3/2023 1:30	1.53	12/3/2023 14:30	0.40	12/4/2023 3:30	1.30	12/4/2023 16:30	0.01	12/5/2023 5:30	1.03	12/5/2023 18:30	0.15
12/2/2023 12:45	0.92	12/3/2023 1:45	1.42	12/3/2023 14:45	0.36	12/4/2023 3:45	1.22	12/4/2023 16:45	-0.02	12/5/2023 5:45	1.01	12/5/2023 18:45	0.14
12/2/2023 13:00	0.81	12/3/2023 2:00	1.50	12/3/2023 15:00	0.40	12/4/2023 4:00	1.23	12/4/2023 17:00	-0.01	12/5/2023 6:00	1.00	12/5/2023 19:00	0.12
12/2/2023 13:15	0.74	12/3/2023 2:15	1.50	12/3/2023 15:15	0.33	12/4/2023 4:15	1.31	12/4/2023 17:15	-0.14	12/5/2023 6:15	0.98	12/5/2023 19:15	0.11
12/2/2023 13:30	0.76	12/3/2023 2:30	1.45	12/3/2023 15:30	0.29	12/4/2023 4:30	1.27	12/4/2023 17:30	-0.14	12/5/2023 6:30	0.95	12/5/2023 19:30	0.10
12/2/2023 13:45	0.75	12/3/2023 2:45	1.42	12/3/2023 15:45	0.26	12/4/2023 4:45	1.33	12/4/2023 17:45	-0.10	12/5/2023 6:45	0.91	12/5/2023 19:45	0.08
12/2/2023 14:00	0.62	12/3/2023 3:00	1.47	12/3/2023 16:00	0.26	12/4/2023 5:00	1.24	12/4/2023 18:00	-0.15	12/5/2023 7:00	0.89	12/5/2023 20:00	0.08
12/2/2023 14:15	0.65	12/3/2023 3:15	1.49	12/3/2023 16:15	0.20	12/4/2023 5:15	1.32	12/4/2023 18:15	-0.18	12/5/2023 7:15	0.86	12/5/2023 20:15	0.09
12/2/2023 14:30	0.57	12/3/2023 3:30	1.55	12/3/2023 16:30	0.20	12/4/2023 5:30	1.23	12/4/2023 18:30	-0.23	12/5/2023 7:30	0.83	12/5/2023 20:30	0.07
12/2/2023 14:45	0.52	12/3/2023 3:45	1.52	12/3/2023 16:45	0.17	12/4/2023 5:45	1.19	12/4/2023 18:45	-0.24	12/5/2023 7:45	0.82	12/5/2023 20:45	0.07
12/2/2023 15:00	0.48	12/3/2023 4:00	1.60	12/3/2023 17:00	0.13	12/4/2023 6:00	1.23	12/4/2023 19:00	-0.25	12/5/2023 8:00	0.76	12/5/2023 21:00	0.06
12/2/2023 15:15	0.44	12/3/2023 4:15	1.54	12/3/2023 17:15	0.12	12/4/2023 6:15	1.15	12/4/2023 19:15	-0.23	12/5/2023 8:15	0.75	12/5/2023 21:15	0.05
12/2/2023 15:30	0.38	12/3/2023 4:30	1.52	12/3/2023 17:30	0.10	12/4/2023 6:30	1.22	12/4/2023 19:30	-0.26	12/5/2023 8:30	0.71	12/5/2023 21:30	0.03
12/2/2023 15:45	0.38	12/3/2023 4:45	1.52	12/3/2023 17:45	0.07	12/4/2023 6:45	1.17	12/4/2023 19:45	-0.26	12/5/2023 8:45	0.67	12/5/2023 21:45	0.02
12/2/2023 16:00	0.32	12/3/2023 5:00	1.51	12/3/2023 18:00	0.03	12/4/2023 7:00	1.14	12/4/2023 20:00	-0.28	12/5/2023 9:00	0.63	12/5/2023 22:00	0.04
12/2/2023 16:15	0.31	12/3/2023 5:15	1.52	12/3/2023 18:15	-0.05	12/4/2023 7:15	1.13	12/4/2023 20:15	-0.27	12/5/2023 9:15	0.59	12/5/2023 22:15	0.05
12/2/2023 16:30	0.26	12/3/2023 5:30	1.52	12/3/2023 18:30	-0.10	12/4/2023 7:30	1.04	12/4/2023 20:30	-0.30	12/5/2023 9:30	0.54	12/5/2023 22:30	0.08
12/2/2023 16:45	0.25	12/3/2023 5:45	1.54	12/3/2023 18:45	-0.08	12/4/2023 7:45	1.04	12/4/2023 20:45	-0.29	12/5/2023 9:45	0.51	12/5/2023 22:45	0.09
12/2/2023 17:00	0.19	12/3/2023 6:00	1.52	12/3/2023 19:00	-0.10	12/4/2023 8:00	1.02	12/4/2023 21:00	-0.28	12/5/2023 10:00	0.48	12/5/2023 23:00	0.13
12/2/2023 17:15	0.16	12/3/2023 6:15	1.51	12/3/2023 19:15	-0.13	12/4/2023 8:15	0.98	12/4/2023 21:15	-0.27	12/5/2023 10:15	0.47	12/5/2023 23:15	0.18
12/2/2023 17:30	0.11	12/3/2023 6:30	1.52	12/3/2023 19:30	-0.14	12/4/2023 8:30	0.89	12/4/2023 21:30	-0.24	12/5/2023 10:30	0.47	12/5/2023 23:30	0.25
12/2/2023 17:45	0.09	12/3/2023 6:45	1.50	12/3/2023 19:45	-0.20	12/4/2023 8:45	0.91	12/4/2023 21:45	-0.19	12/5/2023 10:45	0.42	12/5/2023 23:45	0.26
12/2/2023 18:00	0.13	12/3/2023 7:00	1.49	12/3/2023 20:00	-0.22	12/4/2023 9:00	0.85	12/4/2023 22:00	-0.14	12/5/2023 11:00	0.39	12/6/2023 0:00	0.31
12/2/2023 18:15	0.06	12/3/2023 7:15	1.44	12/3/2023 20:15	-0.23	12/4/2023 9:15	0.81	12/4/2023 22:15	-0.09	12/5/2023 11:15	0.35	12/6/2023 0:15	0.38

Date & Time	Water Level (ft)	Date & Time	Water Level (ft)	Date & Time	Water Level (ft)	Date & Time	Water Level (ft)	Date & Time	Water Level (ft)	Date & Time	Water Level (ft)	Date & Time	Water Level (ft)
12/6/2023 0:30	0.40	12/6/2023 13:30	0.09	12/7/2023 2:30	0.80	12/7/2023 15:30	0.67	12/8/2023 4:30	1.14	12/8/2023 17:30	1.23	12/9/2023 6:30	0.84
12/6/2023 0:45	0.42	12/6/2023 13:45	0.11	12/7/2023 2:45	0.80	12/7/2023 15:45	0.77	12/8/2023 4:45	1.21	12/8/2023 17:45	1.33	12/9/2023 6:45	0.76
12/6/2023 1:00	0.43	12/6/2023 14:00	0.11	12/7/2023 3:00	0.83	12/7/2023 16:00	0.78	12/8/2023 5:00	1.22	12/8/2023 18:00	1.40	12/9/2023 7:00	0.80
12/6/2023 1:15	0.53	12/6/2023 14:15	0.11	12/7/2023 3:15	0.88	12/7/2023 16:15	0.83	12/8/2023 5:15	1.25	12/8/2023 18:15	1.35	12/9/2023 7:15	0.74
12/6/2023 1:30	0.59	12/6/2023 14:30	0.08	12/7/2023 3:30	0.90	12/7/2023 16:30	0.88	12/8/2023 5:30	1.18	12/8/2023 18:30	1.46	12/9/2023 7:30	0.68
12/6/2023 1:45	0.67	12/6/2023 14:45	0.13	12/7/2023 3:45	0.93	12/7/2023 16:45	0.89	12/8/2023 5:45	1.13	12/8/2023 18:45	1.45	12/9/2023 7:45	0.61
12/6/2023 2:00	0.67	12/6/2023 15:00	0.12	12/7/2023 4:00	0.96	12/7/2023 17:00	1.02	12/8/2023 6:00	1.19	12/8/2023 19:00	1.43	12/9/2023 8:00	0.57
12/6/2023 2:15	0.83	12/6/2023 15:15	0.14	12/7/2023 4:15	0.99	12/7/2023 17:15	1.01	12/8/2023 6:15	1.12	12/8/2023 19:15	1.43	12/9/2023 8:15	0.54
12/6/2023 2:30	0.82	12/6/2023 15:30	0.15	12/7/2023 4:30	1.00	12/7/2023 17:30	1.07	12/8/2023 6:30	1.11	12/8/2023 19:30	1.42	12/9/2023 8:30	0.42
12/6/2023 2:45	0.77	12/6/2023 15:45	0.20	12/7/2023 4:45	1.05	12/7/2023 17:45	1.12	12/8/2023 6:45	1.09	12/8/2023 19:45	1.37	12/9/2023 8:45	0.42
12/6/2023 3:00	0.89	12/6/2023 16:00	0.22	12/7/2023 5:00	1.07	12/7/2023 18:00	1.17	12/8/2023 7:00	1.05	12/8/2023 20:00	1.41	12/9/2023 9:00	0.33
12/6/2023 3:15	0.86	12/6/2023 16:15	0.25	12/7/2023 5:15	1.09	12/7/2023 18:15	1.20	12/8/2023 7:15	0.99	12/8/2023 20:15	1.45	12/9/2023 9:15	0.34
12/6/2023 3:30	0.92	12/6/2023 16:30	0.30	12/7/2023 5:30	1.12	12/7/2023 18:30	1.20	12/8/2023 7:30	0.90	12/8/2023 20:30	1.52	12/9/2023 9:30	0.23
12/6/2023 3:45	0.91	12/6/2023 16:45	0.34	12/7/2023 5:45	1.12	12/7/2023 18:45	1.19	12/8/2023 7:45	0.84	12/8/2023 20:45	1.48	12/9/2023 9:45	0.24
12/6/2023 4:00	0.92	12/6/2023 17:00	0.37	12/7/2023 6:00	1.14	12/7/2023 19:00	1.24	12/8/2023 8:00	0.83	12/8/2023 21:00	1.54	12/9/2023 10:00	0.22
12/6/2023 4:15	0.97	12/6/2023 17:15	0.44	12/7/2023 6:15	1.12	12/7/2023 19:15	1.19	12/8/2023 8:15	0.79	12/8/2023 21:15	1.51	12/9/2023 10:15	0.14
12/6/2023 4:30	0.92	12/6/2023 17:30	0.47	12/7/2023 6:30	1.12	12/7/2023 19:30	1.25	12/8/2023 8:30	0.72	12/8/2023 21:30	1.55	12/9/2023 10:30	0.13
12/6/2023 4:45	0.92	12/6/2023 17:45	0.48	12/7/2023 6:45	1.07	12/7/2023 19:45	1.23	12/8/2023 8:45	0.60	12/8/2023 21:45	1.51	12/9/2023 10:45	0.03
12/6/2023 5:00	0.93	12/6/2023 18:00	0.52	12/7/2023 7:00	1.03	12/7/2023 20:00	1.19	12/8/2023 9:00	0.59	12/8/2023 22:00	1.41	12/9/2023 11:00	0.07
12/6/2023 5:15	0.95	12/6/2023 18:15	0.58	12/7/2023 7:15	1.02	12/7/2023 20:15	1.15	12/8/2023 9:15	0.52	12/8/2023 22:15	1.49	12/9/2023 11:15	0.03
12/6/2023 5:30	0.91	12/6/2023 18:30	0.62	12/7/2023 7:30	0.96	12/7/2023 20:30	1.17	12/8/2023 9:30	0.44	12/8/2023 22:30	1.41	12/9/2023 11:30	0.02
12/6/2023 5:45	0.92	12/6/2023 18:45	0.62	12/7/2023 7:45	0.90	12/7/2023 20:45	1.18	12/8/2023 9:45	0.42	12/8/2023 22:45	1.33	12/9/2023 11:45	-0.03
12/6/2023 6:00	0.87	12/6/2023 19:00	0.66	12/7/2023 8:00	0.83	12/7/2023 21:00	1.16	12/8/2023 10:00	0.37	12/8/2023 23:00	1.41	12/9/2023 12:00	-0.03
12/6/2023 6:15	0.90	12/6/2023 19:15	0.70	12/7/2023 8:15	0.82	12/7/2023 21:15	1.14	12/8/2023 10:15	0.34	12/8/2023 23:15	1.34	12/9/2023 12:15	-0.06
12/6/2023 6:30	0.88	12/6/2023 19:30	0.67	12/7/2023 8:30	0.76	12/7/2023 21:30	1.05	12/8/2023 10:30	0.28	12/8/2023 23:30	1.43	12/9/2023 12:30	-0.14
12/6/2023 6:45	0.86	12/6/2023 19:45	0.68	12/7/2023 8:45	0.73	12/7/2023 21:45	1.10	12/8/2023 10:45	0.33	12/8/2023 23:45	1.41	12/9/2023 12:45	-0.18
12/6/2023 7:00	0.82	12/6/2023 20:00	0.71	12/7/2023 9:00	0.70	12/7/2023 22:00	1.01	12/8/2023 11:00	0.22	12/9/2023 0:00	1.38	12/9/2023 13:00	-0.13
12/6/2023 7:15	0.82	12/6/2023 20:15	0.69	12/7/2023 9:15	0.67	12/7/2023 22:15	1.04	12/8/2023 11:15	0.22	12/9/2023 0:15	1.45	12/9/2023 13:15	-0.19
12/6/2023 7:30	0.70	12/6/2023 20:30	0.73	12/7/2023 9:30	0.62	12/7/2023 22:30	1.04	12/8/2023 11:30	0.20	12/9/2023 0:30	1.42	12/9/2023 13:30	-0.24
12/6/2023 7:45	0.66	12/6/2023 20:45	0.72	12/7/2023 9:45	0.60	12/7/2023 22:45	0.94	12/8/2023 11:45	0.17	12/9/2023 0:45	1.39	12/9/2023 13:45	-0.24
12/6/2023 8:00	0.62	12/6/2023 21:00	0.72	12/7/2023 10:00	0.50	12/7/2023 23:00	1.00	12/8/2023 12:00	0.18	12/9/2023 1:00	1.30	12/9/2023 14:00	-0.21
12/6/2023 8:15	0.64	12/6/2023 21:15	0.72	12/7/2023 10:15	0.50	12/7/2023 23:15	0.95	12/8/2023 12:15	0.26	12/9/2023 1:15	1.31	12/9/2023 14:15	-0.21
12/6/2023 8:30	0.59	12/6/2023 21:30	0.67	12/7/2023 10:30	0.43	12/7/2023 23:30	1.00	12/8/2023 12:30	0.27	12/9/2023 1:30	1.24	12/9/2023 14:30	-0.16
12/6/2023 8:45	0.56	12/6/2023 21:45	0.69	12/7/2023 10:45	0.42	12/7/2023 23:45	0.98	12/8/2023 12:45	0.34	12/9/2023 1:45	1.29	12/9/2023 14:45	-0.22
12/6/2023 9:00	0.54	12/6/2023 22:00	0.71	12/7/2023 11:00	0.36	12/8/2023 0:00	0.92	12/8/2023 13:00	0.31	12/9/2023 2:00	1.31	12/9/2023 15:00	-0.15
12/6/2023 9:15	0.48	12/6/2023 22:15	0.64	12/7/2023 11:15	0.32	12/8/2023 0:15	0.96	12/8/2023 13:15	0.25	12/9/2023 2:15	1.23	12/9/2023 15:15	-0.08
12/6/2023 9:30	0.38	12/6/2023 22:30	0.62	12/7/2023 11:30	0.33	12/8/2023 0:30	1.00	12/8/2023 13:30	0.32	12/9/2023 2:30	1.25	12/9/2023 15:30	0.00
12/6/2023 9:45	0.41	12/6/2023 22:45	0.64	12/7/2023 11:45	0.28	12/8/2023 0:45	0.99	12/8/2023 13:45	0.41	12/9/2023 2:45	1.23	12/9/2023 15:45	0.05
12/6/2023 10:00	0.41	12/6/2023 23:00	0.63	12/7/2023 12:00	0.31	12/8/2023 1:00	0.97	12/8/2023 14:00	0.38	12/9/2023 3:00	1.19	12/9/2023 16:00	0.03
12/6/2023 10:15	0.37	12/6/2023 23:15	0.62	12/7/2023 12:15	0.25	12/8/2023 1:15	0.96	12/8/2023 14:15	0.33	12/9/2023 3:15	1.26	12/9/2023 16:15	0.10
12/6/2023 10:30	0.36	12/6/2023 23:30	0.64	12/7/2023 12:30	0.28	12/8/2023 1:30	0.96	12/8/2023 14:30	0.43	12/9/2023 3:30	1.19	12/9/2023 16:30	0.27
12/6/2023 10:45	0.36	12/6/2023 23:45	0.64	12/7/2023 12:45	0.26	12/8/2023 1:45	0.99	12/8/2023 14:45	0.59	12/9/2023 3:45	1.14	12/9/2023 16:45	0.37
12/6/2023 11:00	0.30	12/7/2023 0:00	0.65	12/7/2023 13:00	0.27	12/8/2023 2:00	1.04	12/8/2023 15:00	0.71	12/9/2023 4:00	1.16	12/9/2023 17:00	0.40
12/6/2023 11:15	0.29	12/7/2023 0:15	0.65	12/7/2023 13:15	0.27	12/8/2023 2:15	1.05	12/8/2023 15:15	0.71	12/9/2023 4:15	1.14	12/9/2023 17:15	0.47
12/6/2023 11:30	0.27	12/7/2023 0:30	0.63	12/7/2023 13:30	0.35	12/8/2023 2:30	1.04	12/8/2023 15:30	0.66	12/9/2023 4:30	1.09	12/9/2023 17:30	0.56
12/6/2023 11:45	0.30	12/7/2023 0:45	0.64	12/7/2023 13:45	0.36	12/8/2023 2:45	1.02	12/8/2023 15:45	0.91	12/9/2023 4:45	1.12	12/9/2023 17:45	0.68
12/6/2023 12:00	0.22	12/7/2023 1:00	0.62	12/7/2023 14:00	0.42	12/8/2023 3:00	1.10	12/8/2023 16:00	0.96	12/9/2023 5:00	1.07	12/9/2023 18:00	0.70
12/6/2023 12:15	0.20	12/7/2023 1:15	0.65	12/7/2023 14:15	0.43	12/8/2023 3:15	1.07	12/8/2023 16:15	0.95	12/9/2023 5:15	0.98	12/9/2023 18:15	0.83
12/6/2023 12:30	0.16	12/7/2023 1:30	0.66	12/7/2023 14:30	0.43	12/8/2023 3:30	1.04	12/8/2023 16:30	0.99	12/9/2023 5:30	0.97	12/9/2023 18:30	0.87
12/6/2023 12:45	0.16	12/7/2023 1:45	0.68	12/7/2023 14:45	0.46	12/8/2023 3:45	1.14	12/8/2023 16:45	1.13	12/9/2023 5:45	0.93	12/9/2023 18:45	0.93
12/6/2023 13:00	0.17	12/7/2023 2:00	0.68	12/7/2023 15:00	0.54	12/8/2023 4:00	1.15	12/8/2023 17:00	1.17	12/9/2023 6:00	0.90	12/9/2023 19:00	0.99
12/6/2023 13:15	0.12	12/7/2023 2:15	0.73	12/7/2023 15:15	0.62	12/8/2023 4:15	1.09	12/8/2023 17:15	1.21	12/9/2023 6:15	0.91	12/9/2023 19:15	1.19

Date & Time	Water Level (ft)	Date & Time	Water Level (ft)	Date & Time	Water Level (ft)	Date & Time	Water Level (ft)	Date & Time	Water Level (ft)	Date & Time	Water Level (ft)	Date & Time	Water Level (ft)
12/9/2023 19:30	1.21	12/10/2023 8:30	-1.02	12/10/2023 21:30	-0.16	12/11/2023 10:30	-0.25	12/11/2023 23:30	1.20	12/12/2023 12:30	0.03	12/13/2023 1:30	1.66
12/9/2023 19:45	1.24	12/10/2023 8:45	-1.06	12/10/2023 21:45	-0.09	12/11/2023 10:45	-0.27	12/11/2023 23:45	1.18	12/12/2023 12:45	0.04	12/13/2023 1:45	1.74
12/9/2023 20:00	1.16	12/10/2023 9:00	-1.23	12/10/2023 22:00	-0.01	12/11/2023 11:00	-0.31	12/12/2023 0:00	1.13	12/12/2023 13:00	-0.03	12/13/2023 2:00	1.82
12/9/2023 20:15	1.16	12/10/2023 9:15	-1.20	12/10/2023 22:15	0.05	12/11/2023 11:15	-0.38	12/12/2023 0:15	1.15	12/12/2023 13:15	-0.10	12/13/2023 2:15	1.87
12/9/2023 20:30	1.36	12/10/2023 9:30	-1.22	12/10/2023 22:30	0.09	12/11/2023 11:30	-0.44	12/12/2023 0:30	1.26	12/12/2023 13:30	-0.11	12/13/2023 2:30	1.86
12/9/2023 20:45	1.14	12/10/2023 9:45	-1.36	12/10/2023 22:45	0.15	12/11/2023 11:45	-0.53	12/12/2023 0:45	1.13	12/12/2023 13:45	-0.13	12/13/2023 2:45	1.85
12/9/2023 21:00	1.31	12/10/2023 10:00	-1.32	12/10/2023 23:00	0.19	12/11/2023 12:00	-0.57	12/12/2023 1:00	1.15	12/12/2023 14:00	-0.26	12/13/2023 3:00	1.76
12/9/2023 21:15	1.18	12/10/2023 10:15	-1.45	12/10/2023 23:15	0.21	12/11/2023 12:15	-0.61	12/12/2023 1:15	1.15	12/12/2023 14:15	-0.27	12/13/2023 3:15	1.81
12/9/2023 21:30	1.22	12/10/2023 10:30	-1.49	12/10/2023 23:30	0.25	12/11/2023 12:30	-0.69	12/12/2023 1:30	1.14	12/12/2023 14:30	-0.30	12/13/2023 3:30	1.86
12/9/2023 21:45	1.25	12/10/2023 10:45	-1.55	12/10/2023 23:45	0.23	12/11/2023 12:45	-0.74	12/12/2023 1:45	1.15	12/12/2023 14:45	-0.32	12/13/2023 3:45	1.85
12/9/2023 22:00	1.20	12/10/2023 11:00	-1.66	12/11/2023 0:00	0.26	12/11/2023 13:00	-0.78	12/12/2023 2:00	1.10	12/12/2023 15:00	-0.34	12/13/2023 4:00	1.88
12/9/2023 22:15	1.08	12/10/2023 11:15	-1.66	12/11/2023 0:15	0.30	12/11/2023 13:15	-0.86	12/12/2023 2:15	1.16	12/12/2023 15:15	-0.32	12/13/2023 4:15	1.89
12/9/2023 22:30	1.01	12/10/2023 11:30	-1.72	12/11/2023 0:30	0.24	12/11/2023 13:30	-0.90	12/12/2023 2:30	1.13	12/12/2023 15:30	-0.36	12/13/2023 4:30	1.89
12/9/2023 22:45	1.00	12/10/2023 11:45	-1.79	12/11/2023 0:45	0.35	12/11/2023 13:45	-0.97	12/12/2023 2:45	1.21	12/12/2023 15:45	-0.27	12/13/2023 4:45	1.83
12/9/2023 23:00	0.94	12/10/2023 12:00	-1.74	12/11/2023 1:00	0.30	12/11/2023 14:00	-0.93	12/12/2023 3:00	1.15	12/12/2023 16:00	-0.23	12/13/2023 5:00	1.78
12/9/2023 23:15	0.84	12/10/2023 12:15	-1.87	12/11/2023 1:15	0.30	12/11/2023 14:15	-0.99	12/12/2023 3:15	1.15	12/12/2023 16:15	-0.20	12/13/2023 5:15	1.92
12/9/2023 23:30	0.77	12/10/2023 12:30	-1.94	12/11/2023 1:30	0.35	12/11/2023 14:30	-1.00	12/12/2023 3:30	1.21	12/12/2023 16:30	-0.13	12/13/2023 5:30	1.81
12/9/2023 23:45	0.76	12/10/2023 12:45	-1.96	12/11/2023 1:45	0.36	12/11/2023 14:45	-0.99	12/12/2023 3:45	1.20	12/12/2023 16:45	-0.10	12/13/2023 5:45	1.88
12/10/2023 0:00	0.67	12/10/2023 13:00	-1.93	12/11/2023 2:00	0.31	12/11/2023 15:00	-1.02	12/12/2023 4:00	1.25	12/12/2023 17:00	-0.01	12/13/2023 6:00	1.85
12/10/2023 0:15	0.69	12/10/2023 13:15	-2.03	12/11/2023 2:15	0.29	12/11/2023 15:15	-0.98	12/12/2023 4:15	1.30	12/12/2023 17:15	-0.03	12/13/2023 6:15	1.80
12/10/2023 0:30	0.59	12/10/2023 13:30	-2.02	12/11/2023 2:30	0.29	12/11/2023 15:30	-0.93	12/12/2023 4:30	1.33	12/12/2023 17:30	0.09	12/13/2023 6:30	1.79
12/10/2023 0:45	0.73	12/10/2023 13:45	-2.15	12/11/2023 2:45	0.35	12/11/2023 15:45	-0.92	12/12/2023 4:45	1.33	12/12/2023 17:45	0.20	12/13/2023 6:45	1.76
12/10/2023 1:00	0.81	12/10/2023 14:00	-2.10	12/11/2023 3:00	0.34	12/11/2023 16:00	-0.84	12/12/2023 5:00	1.29	12/12/2023 18:00	0.35	12/13/2023 7:00	1.62
12/10/2023 1:15	0.69	12/10/2023 14:15	-2.18	12/11/2023 3:15	0.26	12/11/2023 16:15	-0.76	12/12/2023 5:15	1.31	12/12/2023 18:15	0.40	12/13/2023 7:15	1.58
12/10/2023 1:30	0.71	12/10/2023 14:30	-2.14	12/11/2023 3:30	0.27	12/11/2023 16:30	-0.65	12/12/2023 5:30	1.26	12/12/2023 18:30	0.57	12/13/2023 7:30	1.52
12/10/2023 1:45	0.62	12/10/2023 14:45	-2.26	12/11/2023 3:45	0.25	12/11/2023 16:45	-0.62	12/12/2023 5:45	1.29	12/12/2023 18:45	0.66	12/13/2023 7:45	1.56
12/10/2023 2:00	0.80	12/10/2023 15:00	-2.26	12/11/2023 4:00	0.28	12/11/2023 17:00	-0.47	12/12/2023 6:00	1.40	12/12/2023 19:00	0.78	12/13/2023 8:00	1.41
12/10/2023 2:15	0.57	12/10/2023 15:15	-2.32	12/11/2023 4:15	0.23	12/11/2023 17:15	-0.38	12/12/2023 6:15	1.31	12/12/2023 19:15	0.92	12/13/2023 8:15	1.40
12/10/2023 2:30	0.43	12/10/2023 15:30	-2.28	12/11/2023 4:30	0.25	12/11/2023 17:30	-0.24	12/12/2023 6:30	1.30	12/12/2023 19:30	0.97	12/13/2023 8:30	1.33
12/10/2023 2:45	0.40	12/10/2023 15:45	-2.29	12/11/2023 4:45	0.32	12/11/2023 17:45	-0.18	12/12/2023 6:45	1.36	12/12/2023 19:45	1.03	12/13/2023 8:45	1.35
12/10/2023 3:00	0.30	12/10/2023 16:00	-2.15	12/11/2023 5:00	0.33	12/11/2023 18:00	-0.09	12/12/2023 7:00	1.37	12/12/2023 20:00	1.17	12/13/2023 9:00	1.34
12/10/2023 3:15	0.31	12/10/2023 16:15	-2.09	12/11/2023 5:15	0.27	12/11/2023 18:15	0.02	12/12/2023 7:15	1.26	12/12/2023 20:15	1.19	12/13/2023 9:15	1.27
12/10/2023 3:30	0.10	12/10/2023 16:30	-2.04	12/11/2023 5:30	0.29	12/11/2023 18:30	0.13	12/12/2023 7:30	1.23	12/12/2023 20:30	1.27	12/13/2023 9:30	1.19
12/10/2023 3:45	0.13	12/10/2023 16:45	-1.95	12/11/2023 5:45	0.35	12/11/2023 18:45	0.26	12/12/2023 7:45	1.17	12/12/2023 20:45	1.31	12/13/2023 9:45	1.22
12/10/2023 4:00	0.14	12/10/2023 17:00	-1.83	12/11/2023 6:00	0.31	12/11/2023 19:00	0.35	12/12/2023 8:00	1.15	12/12/2023 21:00	1.29	12/13/2023 10:00	1.07
12/10/2023 4:15	0.05	12/10/2023 17:15	-1.75	12/11/2023 6:15	0.33	12/11/2023 19:15	0.45	12/12/2023 8:15	1.15	12/12/2023 21:15	1.39	12/13/2023 10:15	1.06
12/10/2023 4:30	-0.09	12/10/2023 17:30	-1.70	12/11/2023 6:30	0.31	12/11/2023 19:30	0.55	12/12/2023 8:30	1.02	12/12/2023 21:30	1.37	12/13/2023 10:30	0.84
12/10/2023 4:45	-0.03	12/10/2023 17:45	-1.62	12/11/2023 6:45	0.33	12/11/2023 19:45	0.67	12/12/2023 8:45	1.02	12/12/2023 21:45	1.40	12/13/2023 10:45	0.80
12/10/2023 5:00	-0.14	12/10/2023 18:00	-1.47	12/11/2023 7:00	0.32	12/11/2023 20:00	0.72	12/12/2023 9:00	0.96	12/12/2023 22:00	1.42	12/13/2023 11:00	0.85
12/10/2023 5:15	-0.21	12/10/2023 18:15	-1.39	12/11/2023 7:15	0.29	12/11/2023 20:15	0.81	12/12/2023 9:15	0.79	12/12/2023 22:15	1.41	12/13/2023 11:15	0.77
12/10/2023 5:30	-0.23	12/10/2023 18:30	-1.32	12/11/2023 7:30	0.28	12/11/2023 20:30	0.88	12/12/2023 9:30	0.84	12/12/2023 22:30	1.46	12/13/2023 11:30	0.63
12/10/2023 5:45	-0.30	12/10/2023 18:45	-1.22	12/11/2023 7:45	0.29	12/11/2023 20:45	0.93	12/12/2023 9:45	0.76	12/12/2023 22:45	1.53	12/13/2023 11:45	0.51
12/10/2023 6:00	-0.26	12/10/2023 19:00	-1.11	12/11/2023 8:00	0.23	12/11/2023 21:00	1.03	12/12/2023 10:00	0.57	12/12/2023 23:00	1.48	12/13/2023 12:00	0.51
12/10/2023 6:15	-0.42	12/10/2023 19:15	-0.99	12/11/2023 8:15	0.21	12/11/2023 21:15	0.98	12/12/2023 10:15	0.57	12/12/2023 23:15	1.44	12/13/2023 12:15	0.40
12/10/2023 6:30	-0.41	12/10/2023 19:30	-0.89	12/11/2023 8:30	0.18	12/11/2023 21:30	1.11	12/12/2023 10:30	0.53	12/12/2023 23:30	1.50	12/13/2023 12:30	0.48
12/10/2023 6:45	-0.58	12/10/2023 19:45	-0.80	12/11/2023 8:45	0.13	12/11/2023 21:45	1.07	12/12/2023 10:45	0.43	12/12/2023 23:45	1.61	12/13/2023 12:45	0.46
12/10/2023 7:00	-0.80	12/10/2023 20:00	-0.70	12/11/2023 9:00	0.02	12/11/2023 22:00	1.10	12/12/2023 11:00	0.40	12/13/2023 0:00	1.58	12/13/2023 13:00	0.50
12/10/2023 7:15	-0.64	12/10/2023 20:15	-0.59	12/11/2023 9:15	-0.02	12/11/2023 22:15	1.14	12/12/2023 11:15	0.25	12/13/2023 0:15	1.67	12/13/2023 13:15	0.31
12/10/2023 7:30	-0.78	12/10/2023 20:30	-0.49	12/11/2023 9:30	0.02	12/11/2023 22:30	1.12	12/12/2023 11:30	0.23	12/13/2023 0:30	1.64	12/13/2023 13:30	0.27
12/10/2023 7:45	-0.85	12/10/2023 20:45	-0.40	12/11/2023 9:45	-0.06	12/11/2023 22:45	1.12	12/12/2023 11:45	0.25	12/13/2023 0:45	1.71	12/13/2023 13:45	0.26
12/10/2023 8:00	-0.92	12/10/2023 21:00	-0.29	12/11/2023 10:00	-0.14	12/11/2023 23:00	1.19	12/12/2023 12:00	0.18	12/13/2023 1:00	1.69	12/13/2023 14:00	0.23
12/10/2023 8:15	-0.93	12/10/2023 21:15	-0.22	12/11/2023 10:15	-0.18	12/11/2023 23:15	1.10	12/12/2023 12:15	0.12	12/13/2023 1:15	1.70	12/13/2023 14:15	0.16

Date & Time	Water Level (ft)	Date & Time	Water Level (ft)	Date & Time	Water Level (ft)	Date & Time	Water Level (ft)	Date & Time	Water Level (ft)	Date & Time	Water Level (ft)	Date & Time	Water Level (ft)
12/13/2023 14:30	0.03	12/14/2023 3:30	1.82	12/14/2023 16:30	0.12	12/15/2023 5:30	2.59	12/15/2023 18:30	1.09	12/16/2023 7:30	2.47	12/16/2023 20:30	0.08
12/13/2023 14:45	0.10	12/14/2023 3:45	1.79	12/14/2023 16:45	0.22	12/15/2023 5:45	2.61	12/15/2023 18:45	1.08	12/16/2023 7:45	2.54	12/16/2023 20:45	0.17
12/13/2023 15:00	0.02	12/14/2023 4:00	1.76	12/14/2023 17:00	0.28	12/15/2023 6:00	2.72	12/15/2023 19:00	1.20	12/16/2023 8:00	2.26	12/16/2023 21:00	0.15
12/13/2023 15:15	-0.10	12/14/2023 4:15	1.84	12/14/2023 17:15	0.23	12/15/2023 6:15	2.61	12/15/2023 19:15	1.22	12/16/2023 8:15	1.89	12/16/2023 21:15	0.14
12/13/2023 15:30	-0.02	12/14/2023 4:30	1.87	12/14/2023 17:30	0.27	12/15/2023 6:30	2.74	12/15/2023 19:30	1.24	12/16/2023 8:30	2.24	12/16/2023 21:30	0.28
12/13/2023 15:45	-0.03	12/14/2023 4:45	1.81	12/14/2023 17:45	0.31	12/15/2023 6:45	2.75	12/15/2023 19:45	1.50	12/16/2023 8:45	2.08	12/16/2023 21:45	0.20
12/13/2023 16:00	-0.04	12/14/2023 5:00	1.92	12/14/2023 18:00	0.33	12/15/2023 7:00	2.77	12/15/2023 20:00	1.53	12/16/2023 9:00	2.18	12/16/2023 22:00	0.32
12/13/2023 16:15	-0.16	12/14/2023 5:15	1.87	12/14/2023 18:15	0.41	12/15/2023 7:15	2.78	12/15/2023 20:15	1.50	12/16/2023 9:15	2.31	12/16/2023 22:15	0.49
12/13/2023 16:30	-0.22	12/14/2023 5:30	1.92	12/14/2023 18:30	0.57	12/15/2023 7:30	2.75	12/15/2023 20:30	1.68	12/16/2023 9:30	2.37	12/16/2023 22:30	0.54
12/13/2023 16:45	-0.20	12/14/2023 5:45	1.99	12/14/2023 18:45	0.63	12/15/2023 7:45	2.75	12/15/2023 20:45	1.67	12/16/2023 9:45	2.19	12/16/2023 22:45	0.65
12/13/2023 17:00	-0.20	12/14/2023 6:00	1.93	12/14/2023 19:00	0.65	12/15/2023 8:00	2.83	12/15/2023 21:00	1.85	12/16/2023 10:00	2.08	12/16/2023 23:00	0.74
12/13/2023 17:15	-0.17	12/14/2023 6:15	1.99	12/14/2023 19:15	0.76	12/15/2023 8:15	2.80	12/15/2023 21:15	1.84	12/16/2023 10:15	1.71	12/16/2023 23:15	0.78
12/13/2023 17:30	-0.12	12/14/2023 6:30	2.03	12/14/2023 19:30	0.87	12/15/2023 8:30	2.84	12/15/2023 21:30	1.97	12/16/2023 10:30	1.86	12/16/2023 23:30	0.93
12/13/2023 17:45	-0.17	12/14/2023 6:45	1.90	12/14/2023 19:45	0.97	12/15/2023 8:45	2.86	12/15/2023 21:45	2.01	12/16/2023 10:45	1.87	12/16/2023 23:45	0.92
12/13/2023 18:00	-0.06	12/14/2023 7:00	1.94	12/14/2023 20:00	1.10	12/15/2023 9:00	2.72	12/15/2023 22:00	2.16	12/16/2023 11:00	1.55	12/17/2023 0:00	1.10
12/13/2023 18:15	-0.01	12/14/2023 7:15	1.97	12/14/2023 20:15	1.12	12/15/2023 9:15	2.72	12/15/2023 22:15	2.23	12/16/2023 11:15	1.53	12/17/2023 0:15	1.13
12/13/2023 18:30	-0.01	12/14/2023 7:30	2.05	12/14/2023 20:30	1.17	12/15/2023 9:30	2.67	12/15/2023 22:30	2.36	12/16/2023 11:30	1.34	12/17/2023 0:30	1.20
12/13/2023 18:45	0.11	12/14/2023 7:45	2.02	12/14/2023 20:45	1.24	12/15/2023 9:45	2.69	12/15/2023 22:45	2.42	12/16/2023 11:45	1.51	12/17/2023 0:45	1.26
12/13/2023 19:00	0.19	12/14/2023 8:00	1.93	12/14/2023 21:00	1.32	12/15/2023 10:00	2.55	12/15/2023 23:00	2.49	12/16/2023 12:00	1.60	12/17/2023 1:00	1.37
12/13/2023 19:15	0.25	12/14/2023 8:15	1.95	12/14/2023 21:15	1.40	12/15/2023 10:15	2.41	12/15/2023 23:15	2.56	12/16/2023 12:15	1.22	12/17/2023 1:15	1.39
12/13/2023 19:30	0.38	12/14/2023 8:30	1.87	12/14/2023 21:30	1.40	12/15/2023 10:30	2.50	12/15/2023 23:30	2.64	12/16/2023 12:30	1.49	12/17/2023 1:30	1.37
12/13/2023 19:45	0.44	12/14/2023 8:45	1.79	12/14/2023 21:45	1.52	12/15/2023 10:45	2.34	12/15/2023 23:45	2.69	12/16/2023 12:45	1.39	12/17/2023 1:45	1.47
12/13/2023 20:00	0.55	12/14/2023 9:00	1.74	12/14/2023 22:00	1.69	12/15/2023 11:00	2.23	12/16/2023 0:00	2.70	12/16/2023 13:00	1.34	12/17/2023 2:00	1.49
12/13/2023 20:15	0.67	12/14/2023 9:15	1.75	12/14/2023 22:15	1.73	12/15/2023 11:15	2.36	12/16/2023 0:15	2.75	12/16/2023 13:15	1.23	12/17/2023 2:15	1.51
12/13/2023 20:30	0.66	12/14/2023 9:30	1.63	12/14/2023 22:30	1.74	12/15/2023 11:30	2.16	12/16/2023 0:30	2.73	12/16/2023 13:30	1.43	12/17/2023 2:30	1.52
12/13/2023 20:45	0.85	12/14/2023 9:45	1.59	12/14/2023 22:45	1.93	12/15/2023 11:45	2.09	12/16/2023 0:45	2.79	12/16/2023 13:45	1.09	12/17/2023 2:45	1.51
12/13/2023 21:00	0.90	12/14/2023 10:00	1.57	12/14/2023 23:00	1.99	12/15/2023 12:00	2.05	12/16/2023 1:00	2.77	12/16/2023 14:00	0.83	12/17/2023 3:00	1.48
12/13/2023 21:15	1.05	12/14/2023 10:15	1.46	12/14/2023 23:15	2.12	12/15/2023 12:15	2.02	12/16/2023 1:15	2.78	12/16/2023 14:15	0.61	12/17/2023 3:15	1.53
12/13/2023 21:30	1.05	12/14/2023 10:30	1.29	12/14/2023 23:30	1.99	12/15/2023 12:30	1.87	12/16/2023 1:30	2.81	12/16/2023 14:30	0.74	12/17/2023 3:30	1.49
12/13/2023 21:45	1.15	12/14/2023 10:45	1.41	12/14/2023 23:45	2.04	12/15/2023 12:45	1.91	12/16/2023 1:45	2.78	12/16/2023 14:45	0.82	12/17/2023 3:45	1.56
12/13/2023 22:00	1.25	12/14/2023 11:00	1.28	12/15/2023 0:00	2.18	12/15/2023 13:00	1.88	12/16/2023 2:00	2.78	12/16/2023 15:00	0.75	12/17/2023 4:00	1.46
12/13/2023 22:15	1.37	12/14/2023 11:15	1.16	12/15/2023 0:15	2.28	12/15/2023 13:15	1.76	12/16/2023 2:15	2.70	12/16/2023 15:15	0.70	12/17/2023 4:15	1.47
12/13/2023 22:30	1.39	12/14/2023 11:30	1.18	12/15/2023 0:30	2.25	12/15/2023 13:30	1.63	12/16/2023 2:30	2.76	12/16/2023 15:30	0.64	12/17/2023 4:30	1.46
12/13/2023 22:45	1.47	12/14/2023 11:45	1.13	12/15/2023 0:45	2.33	12/15/2023 13:45	1.63	12/16/2023 2:45	2.83	12/16/2023 15:45	0.50	12/17/2023 4:45	1.44
12/13/2023 23:00	1.50	12/14/2023 12:00	1.06	12/15/2023 1:00	2.39	12/15/2023 14:00	1.58	12/16/2023 3:00	2.84	12/16/2023 16:00	0.51	12/17/2023 5:00	1.45
12/13/2023 23:15	1.42	12/14/2023 12:15	1.10	12/15/2023 1:15	2.44	12/15/2023 14:15	1.58	12/16/2023 3:15	2.79	12/16/2023 16:15	0.41	12/17/2023 5:15	1.40
12/13/2023 23:30	1.65	12/14/2023 12:30	0.87	12/15/2023 1:30	2.45	12/15/2023 14:30	1.54	12/16/2023 3:30	2.79	12/16/2023 16:30	0.33	12/17/2023 5:30	1.38
12/13/2023 23:45	1.59	12/14/2023 12:45	0.86	12/15/2023 1:45	2.47	12/15/2023 14:45	1.44	12/16/2023 3:45	2.84	12/16/2023 16:45	0.39	12/17/2023 5:45	1.35
12/14/2023 0:00	1.52	12/14/2023 13:00	0.82	12/15/2023 2:00	2.50	12/15/2023 15:00	1.45	12/16/2023 4:00	3.25	12/16/2023 17:00	0.18	12/17/2023 6:00	1.29
12/14/2023 0:15	1.57	12/14/2023 13:15	0.85	12/15/2023 2:15	2.60	12/15/2023 15:15	1.35	12/16/2023 4:15	3.16	12/16/2023 17:15	0.23	12/17/2023 6:15	1.30
12/14/2023 0:30	1.71	12/14/2023 13:30	0.68	12/15/2023 2:30	2.51	12/15/2023 15:30	1.32	12/16/2023 4:30	2.89	12/16/2023 17:30	0.07	12/17/2023 6:30	1.34
12/14/2023 0:45	1.60	12/14/2023 13:45	0.61	12/15/2023 2:45	2.55	12/15/2023 15:45	1.26	12/16/2023 4:45	2.80	12/16/2023 17:45	0.09	12/17/2023 6:45	1.37
12/14/2023 1:00	1.70	12/14/2023 14:00	0.58	12/15/2023 3:00	2.53	12/15/2023 16:00	1.29	12/16/2023 5:00	2.90	12/16/2023 18:00	0.13	12/17/2023 7:00	1.36
12/14/2023 1:15	1.72	12/14/2023 14:15	0.54	12/15/2023 3:15	2.55	12/15/2023 16:15	1.26	12/16/2023 5:15	3.07	12/16/2023 18:15	0.09	12/17/2023 7:15	1.31
12/14/2023 1:30	1.73	12/14/2023 14:30	0.46	12/15/2023 3:30	2.47	12/15/2023 16:30	1.14	12/16/2023 5:30	2.90	12/16/2023 18:30	-0.06	12/17/2023 7:30	1.35
12/14/2023 1:45	1.75	12/14/2023 14:45	0.34	12/15/2023 3:45	2.57	12/15/2023 16:45	1.16	12/16/2023 5:45	2.85	12/16/2023 18:45	0.07	12/17/2023 7:45	1.35
12/14/2023 2:00	1.76	12/14/2023 15:00	0.24	12/15/2023 4:00	2.42	12/15/2023 17:00	1.22	12/16/2023 6:00	2.79	12/16/2023 19:00	0.06	12/17/2023 8:00	1.28
12/14/2023 2:15	1.75	12/14/2023 15:15	0.42	12/15/2023 4:15	2.52	12/15/2023 17:15	1.22	12/16/2023 6:15	2.98	12/16/2023 19:15	-0.11	12/17/2023 8:15	1.33
12/14/2023 2:30	1.78	12/14/2023 15:30	0.30	12/15/2023 4:30	2.60	12/15/2023 17:30	1.29	12/16/2023 6:30	2.92	12/16/2023 19:30	0.02	12/17/2023 8:30	1.41
12/14/2023 2:45	1.78	12/14/2023 15:45	0.35	12/15/2023 4:45	2.63	12/15/2023 17:45	1.03	12/16/2023 6:45	2.51	12/16/2023 19:45	-0.08	12/17/2023 8:45	1.37
12/14/2023 3:00	1.83	12/14/2023 16:00	0.26	12/15/2023 5:00	2.60	12/15/2023 18:00	1.24	12/16/2023 7:00	2.55	12/16/2023 20:00	-0.07	12/17/2023 9:00	1.33
12/14/2023 3:15	1.83	12/14/2023 16:15	0.26	12/15/2023 5:15	2.56	12/15/2023 18:15	1.16	12/16/2023 7:15	2.61	12/16/2023 20:15	0.15	12/17/2023 9:15	1.36

Date & Time	Water Level (ft)	Date & Time	Water Level (ft)	Date & Time	Water Level (ft)	Date & Time	Water Level (ft)	Date & Time	Water Level (ft)	Date & Time	Water Level (ft)	Date & Time	Water Level (ft)
12/17/2023 9:30	1.37	12/17/2023 22:30	0.44	12/18/2023 11:30	0.52	12/19/2023 0:30	0.56	12/19/2023 13:30	1.08	12/20/2023 2:30	1.52	12/20/2023 15:30	1.52
12/17/2023 9:45	1.35	12/17/2023 22:45	0.51	12/18/2023 11:45	0.52	12/19/2023 0:45	0.69	12/19/2023 13:45	1.14	12/20/2023 2:45	1.52	12/20/2023 15:45	1.53
12/17/2023 10:00	1.33	12/17/2023 23:00	0.55	12/18/2023 12:00	0.43	12/19/2023 1:00	0.72	12/19/2023 14:00	1.17	12/20/2023 3:00	1.62	12/20/2023 16:00	1.54
12/17/2023 10:15	1.27	12/17/2023 23:15	0.62	12/18/2023 12:15	0.39	12/19/2023 1:15	0.74	12/19/2023 14:15	1.24	12/20/2023 3:15	1.59	12/20/2023 16:15	1.65
12/17/2023 10:30	1.25	12/17/2023 23:30	0.68	12/18/2023 12:30	0.40	12/19/2023 1:30	0.82	12/19/2023 14:30	1.23	12/20/2023 3:30	1.68	12/20/2023 16:30	1.67
12/17/2023 10:45	1.27	12/17/2023 23:45	0.71	12/18/2023 12:45	0.38	12/19/2023 1:45	0.94	12/19/2023 14:45	1.37	12/20/2023 3:45	1.64	12/20/2023 16:45	1.67
12/17/2023 11:00	1.22	12/18/2023 0:00	0.77	12/18/2023 13:00	0.35	12/19/2023 2:00	0.92	12/19/2023 15:00	1.29	12/20/2023 4:00	1.61	12/20/2023 17:00	1.64
12/17/2023 11:15	1.21	12/18/2023 0:15	0.84	12/18/2023 13:15	0.38	12/19/2023 2:15	0.99	12/19/2023 15:15	1.42	12/20/2023 4:15	1.62	12/20/2023 17:15	1.65
12/17/2023 11:30	1.18	12/18/2023 0:30	0.91	12/18/2023 13:30	0.37	12/19/2023 2:30	1.02	12/19/2023 15:30	1.29	12/20/2023 4:30	1.63	12/20/2023 17:30	1.72
12/17/2023 11:45	1.16	12/18/2023 0:45	0.91	12/18/2023 13:45	0.34	12/19/2023 2:45	1.13	12/19/2023 15:45	1.30	12/20/2023 4:45	1.66	12/20/2023 17:45	1.67
12/17/2023 12:00	1.13	12/18/2023 1:00	0.98	12/18/2023 14:00	0.27	12/19/2023 3:00	1.14	12/19/2023 16:00	1.28	12/20/2023 5:00	1.63	12/20/2023 18:00	1.65
12/17/2023 12:15	1.06	12/18/2023 1:15	1.05	12/18/2023 14:15	0.26	12/19/2023 3:15	1.17	12/19/2023 16:15	1.34	12/20/2023 5:15	1.63	12/20/2023 18:15	1.55
12/17/2023 12:30	0.99	12/18/2023 1:30	1.09	12/18/2023 14:30	0.16	12/19/2023 3:30	1.14	12/19/2023 16:30	1.24	12/20/2023 5:30	1.59	12/20/2023 18:30	1.44
12/17/2023 12:45	0.95	12/18/2023 1:45	1.09	12/18/2023 14:45	0.12	12/19/2023 3:45	1.20	12/19/2023 16:45	1.29	12/20/2023 5:45	1.63	12/20/2023 18:45	1.45
12/17/2023 13:00	0.90	12/18/2023 2:00	1.14	12/18/2023 15:00	0.09	12/19/2023 4:00	1.20	12/19/2023 17:00	1.25	12/20/2023 6:00	1.62	12/20/2023 19:00	1.50
12/17/2023 13:15	0.84	12/18/2023 2:15	1.11	12/18/2023 15:15	0.10	12/19/2023 4:15	1.16	12/19/2023 17:15	1.18	12/20/2023 6:15	1.60	12/20/2023 19:15	1.43
12/17/2023 13:30	0.82	12/18/2023 2:30	1.19	12/18/2023 15:30	0.11	12/19/2023 4:30	1.11	12/19/2023 17:30	1.22	12/20/2023 6:30	1.52	12/20/2023 19:30	1.33
12/17/2023 13:45	0.73	12/18/2023 2:45	1.19	12/18/2023 15:45	0.07	12/19/2023 4:45	1.10	12/19/2023 17:45	1.06	12/20/2023 6:45	1.54	12/20/2023 19:45	1.32
12/17/2023 14:00	0.68	12/18/2023 3:00	1.22	12/18/2023 16:00	0.03	12/19/2023 5:00	1.03	12/19/2023 18:00	1.10	12/20/2023 7:00	1.50	12/20/2023 20:00	1.29
12/17/2023 14:15	0.61	12/18/2023 3:15	1.23	12/18/2023 16:15	-0.11	12/19/2023 5:15	1.04	12/19/2023 18:15	1.01	12/20/2023 7:15	1.45	12/20/2023 20:15	1.22
12/17/2023 14:30	0.56	12/18/2023 3:30	1.21	12/18/2023 16:30	-0.16	12/19/2023 5:30	1.07	12/19/2023 18:30	0.93	12/20/2023 7:30	1.39	12/20/2023 20:30	1.17
12/17/2023 14:45	0.51	12/18/2023 3:45	1.24	12/18/2023 16:45	-0.06	12/19/2023 5:45	0.99	12/19/2023 18:45	0.94	12/20/2023 7:45	1.39	12/20/2023 20:45	1.12
12/17/2023 15:00	0.45	12/18/2023 4:00	1.21	12/18/2023 17:00	-0.12	12/19/2023 6:00	0.90	12/19/2023 19:00	0.84	12/20/2023 8:00	1.43	12/20/2023 21:00	1.00
12/17/2023 15:15	0.38	12/18/2023 4:15	1.24	12/18/2023 17:15	-0.24	12/19/2023 6:15	0.93	12/19/2023 19:15	0.86	12/20/2023 8:15	1.44	12/20/2023 21:15	1.03
12/17/2023 15:30	0.34	12/18/2023 4:30	1.15	12/18/2023 17:30	-0.27	12/19/2023 6:30	0.92	12/19/2023 19:30	0.73	12/20/2023 8:30	1.26	12/20/2023 21:30	1.02
12/17/2023 15:45	0.27	12/18/2023 4:45	1.15	12/18/2023 17:45	-0.33	12/19/2023 6:45	0.89	12/19/2023 19:45	0.71	12/20/2023 8:45	1.24	12/20/2023 21:45	0.96
12/17/2023 16:00	0.24	12/18/2023 5:00	1.20	12/18/2023 18:00	-0.36	12/19/2023 7:00	0.82	12/19/2023 20:00	0.67	12/20/2023 9:00	1.27	12/20/2023 22:00	0.86
12/17/2023 16:15	0.19	12/18/2023 5:15	1.17	12/18/2023 18:15	-0.41	12/19/2023 7:15	0.76	12/19/2023 20:15	0.67	12/20/2023 9:15	1.24	12/20/2023 22:15	0.88
12/17/2023 16:30	0.16	12/18/2023 5:30	1.14	12/18/2023 18:30	-0.42	12/19/2023 7:30	0.75	12/19/2023 20:30	0.59	12/20/2023 9:30	1.27	12/20/2023 22:30	0.80
12/17/2023 16:45	0.11	12/18/2023 5:45	1.08	12/18/2023 18:45	-0.39	12/19/2023 7:45	0.73	12/19/2023 20:45	0.56	12/20/2023 9:45	1.20	12/20/2023 22:45	0.90
12/17/2023 17:00	0.06	12/18/2023 6:00	1.08	12/18/2023 19:00	-0.42	12/19/2023 8:00	0.70	12/19/2023 21:00	0.62	12/20/2023 10:00	1.16	12/20/2023 23:00	0.91
12/17/2023 17:15	0.02	12/18/2023 6:15	0.96	12/18/2023 19:15	-0.43	12/19/2023 8:15	0.68	12/19/2023 21:15	0.61	12/20/2023 10:15	1.12	12/20/2023 23:15	0.82
12/17/2023 17:30	-0.01	12/18/2023 6:30	1.01	12/18/2023 19:30	-0.44	12/19/2023 8:30	0.67	12/19/2023 21:30	0.54	12/20/2023 10:30	1.09	12/20/2023 23:30	0.86
12/17/2023 17:45	-0.04	12/18/2023 6:45	0.99	12/18/2023 19:45	-0.44	12/19/2023 8:45	0.67	12/19/2023 21:45	0.50	12/20/2023 10:45	0.96	12/20/2023 23:45	0.93
12/17/2023 18:00	-0.05	12/18/2023 7:00	0.98	12/18/2023 20:00	-0.48	12/19/2023 9:00	0.64	12/19/2023 22:00	0.58	12/20/2023 11:00	0.94	12/21/2023 0:00	0.85
12/17/2023 18:15	-0.01	12/18/2023 7:15	0.89	12/18/2023 20:15	-0.48	12/19/2023 9:15	0.69	12/19/2023 22:15	0.62	12/20/2023 11:15	0.95	12/21/2023 0:15	0.96
12/17/2023 18:30	-0.04	12/18/2023 7:30	0.90	12/18/2023 20:30	-0.50	12/19/2023 9:30	0.67	12/19/2023 22:30	0.68	12/20/2023 11:30	0.96	12/21/2023 0:30	0.97
12/17/2023 18:45	-0.10	12/18/2023 7:45	0.83	12/18/2023 20:45	-0.46	12/19/2023 9:45	0.66	12/19/2023 22:45	0.67	12/20/2023 11:45	0.93	12/21/2023 0:45	0.98
12/17/2023 19:00	-0.07	12/18/2023 8:00	0.80	12/18/2023 21:00	-0.42	12/19/2023 10:00	0.53	12/19/2023 23:00	0.77	12/20/2023 12:00	0.88	12/21/2023 1:00	1.04
12/17/2023 19:15	-0.05	12/18/2023 8:15	0.80	12/18/2023 21:15	-0.38	12/19/2023 10:15	0.62	12/19/2023 23:15	0.82	12/20/2023 12:15	0.92	12/21/2023 1:15	1.07
12/17/2023 19:30	-0.09	12/18/2023 8:30	0.75	12/18/2023 21:30	-0.34	12/19/2023 10:30	0.61	12/19/2023 23:30	0.87	12/20/2023 12:30	0.97	12/21/2023 1:30	1.14
12/17/2023 19:45	-0.10	12/18/2023 8:45	0.75	12/18/2023 21:45	-0.25	12/19/2023 10:45	0.62	12/19/2023 23:45	0.91	12/20/2023 12:45	1.01	12/21/2023 1:45	1.12
12/17/2023 20:00	-0.03	12/18/2023 9:00	0.73	12/18/2023 22:00	-0.18	12/19/2023 11:00	0.73	12/20/2023 0:00	0.95	12/20/2023 13:00	0.97	12/21/2023 2:00	1.13
12/17/2023 20:15	-0.04	12/18/2023 9:15	0.74	12/18/2023 22:15	-0.10	12/19/2023 11:15	0.76	12/20/2023 0:15	1.07	12/20/2023 13:15	1.02	12/21/2023 2:15	1.12
12/17/2023 20:30	-0.02	12/18/2023 9:30	0.70	12/18/2023 22:30	-0.03	12/19/2023 11:30	0.76	12/20/2023 0:30	1.05	12/20/2023 13:30	1.06	12/21/2023 2:30	1.15
12/17/2023 20:45	0.02	12/18/2023 9:45	0.65	12/18/2023 22:45	0.04	12/19/2023 11:45	0.83	12/20/2023 0:45	1.17	12/20/2023 13:45	1.08	12/21/2023 2:45	1.22
12/17/2023 21:00	0.08	12/18/2023 10:00	0.66	12/18/2023 23:00	0.11	12/19/2023 12:00	0.84	12/20/2023 1:00	1.25	12/20/2023 14:00	1.21	12/21/2023 3:00	1.29
12/17/2023 21:15	0.13	12/18/2023 10:15	0.64	12/18/2023 23:15	0.22	12/19/2023 12:15	0.89	12/20/2023 1:15	1.26	12/20/2023 14:15	1.19	12/21/2023 3:15	1.25
12/17/2023 21:30	0.19	12/18/2023 10:30	0.58	12/18/2023 23:30	0.28	12/19/2023 12:30	0.88	12/20/2023 1:30	1.34	12/20/2023 14:30	1.18	12/21/2023 3:30	1.22
12/17/2023 21:45	0.26	12/18/2023 10:45	0.57	12/18/2023 23:45	0.38	12/19/2023 12:45	0.99	12/20/2023 1:45	1.37	12/20/2023 14:45	1.32	12/21/2023 3:45	1.28
12/17/2023 22:00	0.32	12/18/2023 11:00	0.59	12/19/2023 0:00	0.48	12/19/2023 13:00	0.92	12/20/2023 2:00	1.38	12/20/2023 15:00	1.41	12/21/2023 4:00	1.33
12/17/2023 22:15	0.38	12/18/2023 11:15	0.55	12/19/2023 0:15	0.57	12/19/2023 13:15	1.01	12/20/2023 2:15	1.41	12/20/2023 15:15	1.40	12/21/2023 4:15	1.40

Date & Time	Water Level (ft)	Date & Time	Water Level (ft)	Date & Time	Water Level (ft)	Date & Time	Water Level (ft)	Date & Time	Water Level (ft)	Date & Time	Water Level (ft)	Date & Time	Water Level (ft)
12/21/2023 4:30	1.36	12/21/2023 17:30	1.33	12/22/2023 6:30	1.50	12/22/2023 19:30	1.67	12/23/2023 8:30	0.49	12/23/2023 21:30	1.93	12/24/2023 10:30	1.44
12/21/2023 4:45	1.33	12/21/2023 17:45	1.39	12/22/2023 6:45	1.44	12/22/2023 19:45	1.71	12/23/2023 8:45	0.44	12/23/2023 21:45	1.92	12/24/2023 10:45	1.46
12/21/2023 5:00	1.22	12/21/2023 18:00	1.42	12/22/2023 7:00	1.39	12/22/2023 20:00	1.69	12/23/2023 9:00	0.46	12/23/2023 22:00	2.00	12/24/2023 11:00	1.38
12/21/2023 5:15	1.20	12/21/2023 18:15	1.46	12/22/2023 7:15	1.27	12/22/2023 20:15	1.71	12/23/2023 9:15	0.36	12/23/2023 22:15	1.88	12/24/2023 11:15	1.34
12/21/2023 5:30	1.25	12/21/2023 18:30	1.51	12/22/2023 7:30	1.22	12/22/2023 20:30	1.69	12/23/2023 9:30	0.28	12/23/2023 22:30	2.03	12/24/2023 11:30	1.27
12/21/2023 5:45	1.22	12/21/2023 18:45	1.50	12/22/2023 7:45	1.21	12/22/2023 20:45	1.60	12/23/2023 9:45	0.24	12/23/2023 22:45	1.93	12/24/2023 11:45	1.27
12/21/2023 6:00	1.18	12/21/2023 19:00	1.51	12/22/2023 8:00	1.13	12/22/2023 21:00	1.71	12/23/2023 10:00	0.24	12/23/2023 23:00	1.86	12/24/2023 12:00	1.22
12/21/2023 6:15	1.16	12/21/2023 19:15	1.51	12/22/2023 8:15	1.01	12/22/2023 21:15	1.60	12/23/2023 10:15	0.14	12/23/2023 23:15	1.83	12/24/2023 12:15	1.20
12/21/2023 6:30	1.09	12/21/2023 19:30	1.50	12/22/2023 8:30	1.04	12/22/2023 21:30	1.62	12/23/2023 10:30	0.08	12/23/2023 23:30	1.92	12/24/2023 12:30	1.18
12/21/2023 6:45	1.10	12/21/2023 19:45	1.51	12/22/2023 8:45	0.90	12/22/2023 21:45	1.56	12/23/2023 10:45	0.10	12/23/2023 23:45	1.84	12/24/2023 12:45	1.22
12/21/2023 7:00	0.99	12/21/2023 20:00	1.49	12/22/2023 9:00	0.91	12/22/2023 22:00	1.56	12/23/2023 11:00	0.04	12/24/2023 0:00	1.92	12/24/2023 13:00	1.07
12/21/2023 7:15	1.01	12/21/2023 20:15	1.50	12/22/2023 9:15	0.85	12/22/2023 22:15	1.55	12/23/2023 11:15	0.04	12/24/2023 0:15	1.98	12/24/2023 13:15	1.36
12/21/2023 7:30	0.94	12/21/2023 20:30	1.56	12/22/2023 9:30	0.73	12/22/2023 22:30	1.50	12/23/2023 11:30	0.01	12/24/2023 0:30	2.03	12/24/2023 13:30	1.00
12/21/2023 7:45	0.80	12/21/2023 20:45	1.40	12/22/2023 9:45	0.79	12/22/2023 22:45	1.47	12/23/2023 11:45	-0.08	12/24/2023 0:45	2.04	12/24/2023 13:45	1.01
12/21/2023 8:00	0.74	12/21/2023 21:00	1.45	12/22/2023 10:00	0.68	12/22/2023 23:00	1.48	12/23/2023 12:00	-0.03	12/24/2023 1:00	2.05	12/24/2023 14:00	0.98
12/21/2023 8:15	0.78	12/21/2023 21:15	1.37	12/22/2023 10:15	0.64	12/22/2023 23:15	1.45	12/23/2023 12:15	-0.10	12/24/2023 1:15	2.13	12/24/2023 14:15	1.01
12/21/2023 8:30	0.66	12/21/2023 21:30	1.45	12/22/2023 10:30	0.59	12/22/2023 23:30	1.39	12/23/2023 12:30	-0.10	12/24/2023 1:30	2.18	12/24/2023 14:30	0.97
12/21/2023 8:45	0.62	12/21/2023 21:45	1.40	12/22/2023 10:45	0.60	12/22/2023 23:45	1.35	12/23/2023 12:45	-0.06	12/24/2023 1:45	2.30	12/24/2023 14:45	0.90
12/21/2023 9:00	0.57	12/21/2023 22:00	1.42	12/22/2023 11:00	0.49	12/23/2023 0:00	1.29	12/23/2023 13:00	-0.12	12/24/2023 2:00	2.36	12/24/2023 15:00	1.03
12/21/2023 9:15	0.54	12/21/2023 22:15	1.37	12/22/2023 11:15	0.50	12/23/2023 0:15	1.27	12/23/2023 13:15	-0.09	12/24/2023 2:15	2.41	12/24/2023 15:15	1.01
12/21/2023 9:30	0.54	12/21/2023 22:30	1.40	12/22/2023 11:30	0.52	12/23/2023 0:30	1.24	12/23/2023 13:30	-0.10	12/24/2023 2:30	2.47	12/24/2023 15:30	1.11
12/21/2023 9:45	0.43	12/21/2023 22:45	1.34	12/22/2023 11:45	0.48	12/23/2023 0:45	1.22	12/23/2023 13:45	-0.06	12/24/2023 2:45	2.49	12/24/2023 15:45	1.15
12/21/2023 10:00	0.42	12/21/2023 23:00	1.39	12/22/2023 12:00	0.45	12/23/2023 1:00	1.21	12/23/2023 14:00	-0.02	12/24/2023 3:00	2.51	12/24/2023 16:00	1.30
12/21/2023 10:15	0.39	12/21/2023 23:15	1.41	12/22/2023 12:15	0.35	12/23/2023 1:15	1.25	12/23/2023 14:15	-0.01	12/24/2023 3:15	2.36	12/24/2023 16:15	1.42
12/21/2023 10:30	0.32	12/21/2023 23:30	1.39	12/22/2023 12:30	0.37	12/23/2023 1:30	1.25	12/23/2023 14:30	0.00	12/24/2023 3:30	2.49	12/24/2023 16:30	1.54
12/21/2023 10:45	0.32	12/21/2023 23:45	1.40	12/22/2023 12:45	0.35	12/23/2023 1:45	1.25	12/23/2023 14:45	0.14	12/24/2023 3:45	2.53	12/24/2023 16:45	1.68
12/21/2023 11:00	0.31	12/22/2023 0:00	1.40	12/22/2023 13:00	0.34	12/23/2023 2:00	1.23	12/23/2023 15:00	0.27	12/24/2023 4:00	2.49	12/24/2023 17:00	1.79
12/21/2023 11:15	0.33	12/22/2023 0:15	1.43	12/22/2023 13:15	0.33	12/23/2023 2:15	1.20	12/23/2023 15:15	0.25	12/24/2023 4:15	2.49	12/24/2023 17:15	1.90
12/21/2023 11:30	0.23	12/22/2023 0:30	1.42	12/22/2023 13:30	0.39	12/23/2023 2:30	1.19	12/23/2023 15:30	0.37	12/24/2023 4:30	2.54	12/24/2023 17:30	1.94
12/21/2023 11:45	0.25	12/22/2023 0:45	1.46	12/22/2023 13:45	0.42	12/23/2023 2:45	1.18	12/23/2023 15:45	0.42	12/24/2023 4:45	2.48	12/24/2023 17:45	2.00
12/21/2023 12:00	0.28	12/22/2023 1:00	1.53	12/22/2023 14:00	0.42	12/23/2023 3:00	1.17	12/23/2023 16:00	0.46	12/24/2023 5:00	2.55	12/24/2023 18:00	2.04
12/21/2023 12:15	0.18	12/22/2023 1:15	1.53	12/22/2023 14:15	0.43	12/23/2023 3:15	1.14	12/23/2023 16:15	0.59	12/24/2023 5:15	2.58	12/24/2023 18:15	2.14
12/21/2023 12:30	0.27	12/22/2023 1:30	1.59	12/22/2023 14:30	0.48	12/23/2023 3:30	1.13	12/23/2023 16:30	0.66	12/24/2023 5:30	2.50	12/24/2023 18:30	2.17
12/21/2023 12:45	0.22	12/22/2023 1:45	1.57	12/22/2023 14:45	0.48	12/23/2023 3:45	1.15	12/23/2023 16:45	0.82	12/24/2023 5:45	2.39	12/24/2023 18:45	2.26
12/21/2023 13:00	0.23	12/22/2023 2:00	1.66	12/22/2023 15:00	0.53	12/23/2023 4:00	1.17	12/23/2023 17:00	0.88	12/24/2023 6:00	2.30	12/24/2023 19:00	2.33
12/21/2023 13:15	0.32	12/22/2023 2:15	1.60	12/22/2023 15:15	0.64	12/23/2023 4:15	1.14	12/23/2023 17:15	0.96	12/24/2023 6:15	2.29	12/24/2023 19:15	2.44
12/21/2023 13:30	0.35	12/22/2023 2:30	1.68	12/22/2023 15:30	0.74	12/23/2023 4:30	1.16	12/23/2023 17:30	1.09	12/24/2023 6:30	2.22	12/24/2023 19:30	2.52
12/21/2023 13:45	0.33	12/22/2023 2:45	1.69	12/22/2023 15:45	0.80	12/23/2023 4:45	1.14	12/23/2023 17:45	1.17	12/24/2023 6:45	2.26	12/24/2023 19:45	2.60
12/21/2023 14:00	0.48	12/22/2023 3:00	1.71	12/22/2023 16:00	0.82	12/23/2023 5:00	1.11	12/23/2023 18:00	1.26	12/24/2023 7:00	2.11	12/24/2023 20:00	2.63
12/21/2023 14:15	0.55	12/22/2023 3:15	1.70	12/22/2023 16:15	0.90	12/23/2023 5:15	1.09	12/23/2023 18:15	1.35	12/24/2023 7:15	2.15	12/24/2023 20:15	2.61
12/21/2023 14:30	0.60	12/22/2023 3:30	1.76	12/22/2023 16:30	1.09	12/23/2023 5:30	1.05	12/23/2023 18:30	1.43	12/24/2023 7:30	2.11	12/24/2023 20:30	2.64
12/21/2023 14:45	0.66	12/22/2023 3:45	1.74	12/22/2023 16:45	1.16	12/23/2023 5:45	1.01	12/23/2023 18:45	1.47	12/24/2023 7:45	2.00	12/24/2023 20:45	2.56
12/21/2023 15:00	0.72	12/22/2023 4:00	1.76	12/22/2023 17:00	1.19	12/23/2023 6:00	1.01	12/23/2023 19:00	1.57	12/24/2023 8:00	2.02	12/24/2023 21:00	2.56
12/21/2023 15:15	0.76	12/22/2023 4:15	1.79	12/22/2023 17:15	1.26	12/23/2023 6:15	0.93	12/23/2023 19:15	1.59	12/24/2023 8:15	2.01	12/24/2023 21:15	2.56
12/21/2023 15:30	0.86	12/22/2023 4:30	1.74	12/22/2023 17:30	1.37	12/23/2023 6:30	0.94	12/23/2023 19:30	1.69	12/24/2023 8:30	1.89	12/24/2023 21:30	2.55
12/21/2023 15:45	0.96	12/22/2023 4:45	1.73	12/22/2023 17:45	1.39	12/23/2023 6:45	0.86	12/23/2023 19:45	1.74	12/24/2023 8:45	1.90	12/24/2023 21:45	2.56
12/21/2023 16:00	0.97	12/22/2023 5:00	1.67	12/22/2023 18:00	1.52	12/23/2023 7:00	0.79	12/23/2023 20:00	1.78	12/24/2023 9:00	1.82	12/24/2023 22:00	2.55
12/21/2023 16:15	1.04	12/22/2023 5:15	1.73	12/22/2023 18:15	1.55	12/23/2023 7:15	0.82	12/23/2023 20:15	1.80	12/24/2023 9:15	1.82	12/24/2023 22:15	2.54
12/21/2023 16:30	1.14	12/22/2023 5:30	1.59	12/22/2023 18:30	1.57	12/23/2023 7:30	0.74	12/23/2023 20:30	1.81	12/24/2023 9:30	1.63	12/24/2023 22:30	2.48
12/21/2023 16:45	1.23	12/22/2023 5:45	1.59	12/22/2023 18:45	1.63	12/23/2023 7:45	0.67	12/23/2023 20:45	1.86	12/24/2023 9:45	1.65	12/24/2023 22:45	2.51
12/21/2023 17:00	1.24	12/22/2023 6:00	1.54	12/22/2023 19:00	1.64	12/23/2023 8:00	0.59	12/23/2023 21:00	1.93	12/24/2023 10:00	1.61	12/24/2023 23:00	2.44
12/21/2023 17:15	1.32	12/22/2023 6:15	1.49	12/22/2023 19:15	1.75	12/23/2023 8:15	0.58	12/23/2023 21:15	1.90	12/24/2023 10:15	1.54	12/24/2023 23:15	2.43

Date & Time	Water Level (ft)	Date & Time	Water Level (ft)	Date & Time	Water Level (ft)	Date & Time	Water Level (ft)	Date & Time	Water Level (ft)	Date & Time	Water Level (ft)	Date & Time	Water Level (ft)
12/24/2023 23:30	2.39	12/25/2023 12:30	0.08	12/26/2023 1:30	0.68	12/26/2023 14:30	-0.56	12/27/2023 3:30	1.66	12/27/2023 16:30	-0.42	12/28/2023 5:30	0.91
12/24/2023 23:45	2.38	12/25/2023 12:45	0.01	12/26/2023 1:45	0.73	12/26/2023 14:45	-0.54	12/27/2023 3:45	1.70	12/27/2023 16:45	-0.37	12/28/2023 5:45	0.87
12/25/2023 0:00	2.33	12/25/2023 13:00	-0.09	12/26/2023 2:00	0.69	12/26/2023 15:00	-0.56	12/27/2023 4:00	1.69	12/27/2023 17:00	-0.37	12/28/2023 6:00	0.77
12/25/2023 0:15	2.33	12/25/2023 13:15	-0.30	12/26/2023 2:15	0.73	12/26/2023 15:15	-0.49	12/27/2023 4:15	1.69	12/27/2023 17:15	-0.41	12/28/2023 6:15	0.78
12/25/2023 0:30	2.31	12/25/2023 13:30	-0.37	12/26/2023 2:30	0.70	12/26/2023 15:30	-0.47	12/27/2023 4:30	1.67	12/27/2023 17:30	-0.35	12/28/2023 6:30	0.74
12/25/2023 0:45	2.31	12/25/2023 13:45	-0.25	12/26/2023 2:45	0.74	12/26/2023 15:45	-0.45	12/27/2023 4:45	1.66	12/27/2023 17:45	-0.35	12/28/2023 6:45	0.73
12/25/2023 1:00	2.21	12/25/2023 14:00	-0.36	12/26/2023 3:00	0.67	12/26/2023 16:00	-0.40	12/27/2023 5:00	1.66	12/27/2023 18:00	-0.22	12/28/2023 7:00	0.75
12/25/2023 1:15	2.23	12/25/2023 14:15	-0.37	12/26/2023 3:15	0.64	12/26/2023 16:15	-0.30	12/27/2023 5:15	1.63	12/27/2023 18:15	-0.23	12/28/2023 7:15	0.71
12/25/2023 1:30	2.21	12/25/2023 14:30	-0.50	12/26/2023 3:30	0.65	12/26/2023 16:30	-0.23	12/27/2023 5:30	1.62	12/27/2023 18:30	-0.21	12/28/2023 7:30	0.67
12/25/2023 1:45	2.19	12/25/2023 14:45	-0.51	12/26/2023 3:45	0.63	12/26/2023 16:45	-0.16	12/27/2023 5:45	1.61	12/27/2023 18:45	-0.12	12/28/2023 7:45	0.65
12/25/2023 2:00	2.25	12/25/2023 15:00	-0.44	12/26/2023 4:00	0.62	12/26/2023 17:00	-0.12	12/27/2023 6:00	1.59	12/27/2023 19:00	0.09	12/28/2023 8:00	0.62
12/25/2023 2:15	2.29	12/25/2023 15:15	-0.43	12/26/2023 4:15	0.60	12/26/2023 17:15	-0.03	12/27/2023 6:15	1.59	12/27/2023 19:15	0.12	12/28/2023 8:15	0.49
12/25/2023 2:30	2.39	12/25/2023 15:30	-0.52	12/26/2023 4:30	0.62	12/26/2023 17:30	0.11	12/27/2023 6:30	1.54	12/27/2023 19:30	0.21	12/28/2023 8:30	0.55
12/25/2023 2:45	1.75	12/25/2023 15:45	-0.54	12/26/2023 4:45	0.61	12/26/2023 17:45	0.16	12/27/2023 6:45	1.49	12/27/2023 19:45	0.20	12/28/2023 8:45	0.52
12/25/2023 3:00	1.96	12/25/2023 16:00	-0.58	12/26/2023 5:00	0.62	12/26/2023 18:00	0.22	12/27/2023 7:00	1.47	12/27/2023 20:00	0.31	12/28/2023 9:00	0.37
12/25/2023 3:15	2.14	12/25/2023 16:15	-0.56	12/26/2023 5:15	0.57	12/26/2023 18:15	0.29	12/27/2023 7:15	1.42	12/27/2023 20:15	0.41	12/28/2023 9:15	0.32
12/25/2023 3:30	2.11	12/25/2023 16:30	-0.63	12/26/2023 5:30	0.56	12/26/2023 18:30	0.40	12/27/2023 7:30	1.34	12/27/2023 20:30	0.52	12/28/2023 9:30	0.35
12/25/2023 3:45	2.06	12/25/2023 16:45	-0.51	12/26/2023 5:45	0.59	12/26/2023 18:45	0.55	12/27/2023 7:45	1.37	12/27/2023 20:45	0.57	12/28/2023 9:45	0.26
12/25/2023 4:00	2.09	12/25/2023 17:00	-0.34	12/26/2023 6:00	0.58	12/26/2023 19:00	0.64	12/27/2023 8:00	1.31	12/27/2023 21:00	0.67	12/28/2023 10:00	0.20
12/25/2023 4:15	1.84	12/25/2023 17:15	-0.25	12/26/2023 6:15	0.55	12/26/2023 19:15	0.73	12/27/2023 8:15	1.23	12/27/2023 21:15	0.73	12/28/2023 10:15	0.26
12/25/2023 4:30	1.62	12/25/2023 17:30	-0.27	12/26/2023 6:30	0.57	12/26/2023 19:30	0.78	12/27/2023 8:30	1.22	12/27/2023 21:30	0.81	12/28/2023 10:30	0.22
12/25/2023 4:45	1.53	12/25/2023 17:45	-0.26	12/26/2023 6:45	0.55	12/26/2023 19:45	0.88	12/27/2023 8:45	1.03	12/27/2023 21:45	0.90	12/28/2023 10:45	0.19
12/25/2023 5:00	1.77	12/25/2023 18:00	-0.13	12/26/2023 7:00	0.54	12/26/2023 20:00	0.97	12/27/2023 9:00	1.12	12/27/2023 22:00	1.03	12/28/2023 11:00	0.05
12/25/2023 5:15	1.67	12/25/2023 18:15	0.01	12/26/2023 7:15	0.58	12/26/2023 20:15	1.03	12/27/2023 9:15	0.95	12/27/2023 22:15	1.04	12/28/2023 11:15	-0.03
12/25/2023 5:30	1.69	12/25/2023 18:30	0.11	12/26/2023 7:30	0.53	12/26/2023 20:30	1.09	12/27/2023 9:30	0.87	12/27/2023 22:30	1.11	12/28/2023 11:30	-0.08
12/25/2023 5:45	1.68	12/25/2023 18:45	0.16	12/26/2023 7:45	0.46	12/26/2023 20:45	1.20	12/27/2023 9:45	0.97	12/27/2023 22:45	1.17	12/28/2023 11:45	-0.04
12/25/2023 6:00	1.57	12/25/2023 19:00	0.13	12/26/2023 8:00	0.47	12/26/2023 21:00	1.24	12/27/2023 10:00	0.81	12/27/2023 23:00	1.13	12/28/2023 12:00	-0.09
12/25/2023 6:15	1.48	12/25/2023 19:15	0.26	12/26/2023 8:15	0.41	12/26/2023 21:15	1.32	12/27/2023 10:15	0.79	12/27/2023 23:15	0.89	12/28/2023 12:15	-0.13
12/25/2023 6:30	1.32	12/25/2023 19:30	0.40	12/26/2023 8:30	0.41	12/26/2023 21:30	1.37	12/27/2023 10:30	0.72	12/27/2023 23:30	1.17	12/28/2023 12:30	-0.23
12/25/2023 6:45	1.43	12/25/2023 19:45	0.45	12/26/2023 8:45	0.38	12/26/2023 21:45	1.36	12/27/2023 10:45	0.60	12/27/2023 23:45	1.22	12/28/2023 12:45	-0.25
12/25/2023 7:00	1.29	12/25/2023 20:00	0.50	12/26/2023 9:00	0.32	12/26/2023 22:00	1.46	12/27/2023 11:00	0.54	12/28/2023 0:00	1.07	12/28/2023 13:00	-0.26
12/25/2023 7:15	1.32	12/25/2023 20:15	0.67	12/26/2023 9:15	0.29	12/26/2023 22:15	1.47	12/27/2023 11:15	0.51	12/28/2023 0:15	1.21	12/28/2023 13:15	-0.31
12/25/2023 7:30	1.07	12/25/2023 20:30	0.60	12/26/2023 9:30	0.28	12/26/2023 22:30	1.50	12/27/2023 11:30	0.41	12/28/2023 0:30	1.30	12/28/2023 13:30	-0.47
12/25/2023 7:45	1.13	12/25/2023 20:45	0.72	12/26/2023 9:45	0.27	12/26/2023 22:45	1.56	12/27/2023 11:45	0.38	12/28/2023 0:45	1.37	12/28/2023 13:45	-0.40
12/25/2023 8:00	1.01	12/25/2023 21:00	0.70	12/26/2023 10:00	0.21	12/26/2023 23:00	1.60	12/27/2023 12:00	0.26	12/28/2023 1:00	1.26	12/28/2023 14:00	-0.41
12/25/2023 8:15	1.05	12/25/2023 21:15	0.84	12/26/2023 10:15	0.11	12/26/2023 23:15	1.57	12/27/2023 12:15	0.28	12/28/2023 1:15	1.27	12/28/2023 14:15	-0.46
12/25/2023 8:30	1.00	12/25/2023 21:30	0.90	12/26/2023 10:30	0.10	12/26/2023 23:30	1.57	12/27/2023 12:30	0.15	12/28/2023 1:30	1.22	12/28/2023 14:30	-0.51
12/25/2023 8:45	0.81	12/25/2023 21:45	0.96	12/26/2023 10:45	0.06	12/26/2023 23:45	1.62	12/27/2023 12:45	0.28	12/28/2023 1:45	1.26	12/28/2023 14:45	-0.56
12/25/2023 9:00	0.76	12/25/2023 22:00	1.00	12/26/2023 11:00	-0.04	12/27/2023 0:00	1.62	12/27/2023 13:00	0.16	12/28/2023 2:00	1.19	12/28/2023 15:00	-0.56
12/25/2023 9:15	0.87	12/25/2023 22:15	0.98	12/26/2023 11:15	-0.11	12/27/2023 0:15	1.67	12/27/2023 13:15	0.10	12/28/2023 2:15	1.13	12/28/2023 15:15	-0.72
12/25/2023 9:30	0.86	12/25/2023 22:30	1.05	12/26/2023 11:30	-0.10	12/27/2023 0:30	1.68	12/27/2023 13:30	0.06	12/28/2023 2:30	1.18	12/28/2023 15:30	-0.78
12/25/2023 9:45	0.80	12/25/2023 22:45	0.96	12/26/2023 11:45	-0.22	12/27/2023 0:45	1.68	12/27/2023 13:45	0.04	12/28/2023 2:45	1.16	12/28/2023 15:45	-0.85
12/25/2023 10:00	0.68	12/25/2023 23:00	1.05	12/26/2023 12:00	-0.17	12/27/2023 1:00	1.68	12/27/2023 14:00	0.08	12/28/2023 3:00	1.14	12/28/2023 16:00	-0.84
12/25/2023 10:15	0.54	12/25/2023 23:15	0.92	12/26/2023 12:15	-0.25	12/27/2023 1:15	1.67	12/27/2023 14:15	0.02	12/28/2023 3:15	1.15	12/28/2023 16:15	-0.95
12/25/2023 10:30	0.42	12/25/2023 23:30	1.08	12/26/2023 12:30	-0.26	12/27/2023 1:30	1.72	12/27/2023 14:30	-0.10	12/28/2023 3:30	1.09	12/28/2023 16:30	-0.93
12/25/2023 10:45	0.50	12/25/2023 23:45	1.07	12/26/2023 12:45	-0.31	12/27/2023 1:45	1.73	12/27/2023 14:45	-0.23	12/28/2023 3:45	1.08	12/28/2023 16:45	-1.02
12/25/2023 11:00	0.34	12/26/2023 0:00	0.94	12/26/2023 13:00	-0.34	12/27/2023 2:00	1.71	12/27/2023 15:00	-0.14	12/28/2023 4:00	1.07	12/28/2023 17:00	-1.05
12/25/2023 11:15	0.30	12/26/2023 0:15	1.04	12/26/2023 13:15	-0.36	12/27/2023 2:15	1.71	12/27/2023 15:15	-0.24	12/28/2023 4:15	1.06	12/28/2023 17:15	-1.04
12/25/2023 11:30	0.25	12/26/2023 0:30	0.97	12/26/2023 13:30	-0.45	12/27/2023 2:30	1.69	12/27/2023 15:30	-0.25	12/28/2023 4:30	1.03	12/28/2023 17:30	-1.13
12/25/2023 11:45	0.11	12/26/2023 0:45	0.82	12/26/2023 13:45	-0.41	12/27/2023 2:45	1.68	12/27/2023 15:45	-0.27	12/28/2023 4:45	1.00	12/28/2023 17:45	-1.10
12/25/2023 12:00	0.18	12/26/2023 1:00	0.95	12/26/2023 14:00	-0.47	12/27/2023 3:00	1.67	12/27/2023 16:00	-0.32	12/28/2023 5:00	1.00	12/28/2023 18:00	-1.06
12/25/2023 12:15	-0.03	12/26/2023 1:15	0.85	12/26/2023 14:15	-0.52	12/27/2023 3:15	1.68	12/27/2023 16:15	-0.35	12/28/2023 5:15	0.90	12/28/2023 18:15	-1.05

Date & Time	Water Level (ft)	Date & Time	Water Level (ft)	Date & Time	Water Level (ft)	Date & Time	Water Level (ft)	Date & Time	Water Level (ft)	Date & Time	Water Level (ft)	Date & Time	Water Level (ft)
12/28/2023 18:30	-1.06	12/29/2023 7:30	0.06	12/29/2023 20:30	-1.01	12/30/2023 9:30	-0.40	12/30/2023 22:30	-0.22	12/31/2023 11:30	0.05	1/10/2024 22:15	0.58
12/28/2023 18:45	-1.04	12/29/2023 7:45	-0.02	12/29/2023 20:45	-0.94	12/30/2023 9:45	-0.42	12/30/2023 22:45	-0.15	12/31/2023 11:45	0.04	1/10/2024 22:30	0.61
12/28/2023 19:00	-0.92	12/29/2023 8:00	-0.06	12/29/2023 21:00	-0.87	12/30/2023 10:00	-0.42	12/30/2023 23:00	-0.07	12/31/2023 12:00	-0.02	1/10/2024 22:45	0.68
12/28/2023 19:15	-0.86	12/29/2023 8:15	-0.05	12/29/2023 21:15	-0.77	12/30/2023 10:15	-0.45	12/30/2023 23:15	0.00	12/31/2023 12:15	-0.08	1/10/2024 23:00	0.71
12/28/2023 19:30	-0.81	12/29/2023 8:30	-0.18	12/29/2023 21:30	-0.68	12/30/2023 10:30	-0.48	12/30/2023 23:30	0.04	12/31/2023 12:30	-0.11	1/10/2024 23:15	0.75
12/28/2023 19:45	-0.73	12/29/2023 8:45	-0.20	12/29/2023 21:45	-0.59	12/30/2023 10:45	-0.48	12/30/2023 23:45	0.08	12/31/2023 12:45	-0.12	1/10/2024 23:30	0.79
12/28/2023 20:00	-0.68	12/29/2023 9:00	-0.26	12/29/2023 22:00	-0.55	12/30/2023 11:00	-0.52	12/31/2023 0:00	0.11	12/31/2023 13:00	-0.18	1/10/2024 23:45	0.83
12/28/2023 20:15	-0.64	12/29/2023 9:15	-0.26	12/29/2023 22:15	-0.43	12/30/2023 11:15	-0.53	12/31/2023 0:15	0.15	12/31/2023 13:15	-0.19	1/11/2024 0:00	0.85
12/28/2023 20:30	-0.54	12/29/2023 9:30	-0.32	12/29/2023 22:30	-0.33	12/30/2023 11:30	-0.53	12/31/2023 0:30	0.20	12/31/2023 13:30	-0.28	1/11/2024 0:15	0.85
12/28/2023 20:45	-0.45	12/29/2023 9:45	-0.29	12/29/2023 22:45	-0.25	12/30/2023 11:45	-0.57	12/31/2023 0:45	0.24	12/31/2023 13:45	-0.30	1/11/2024 0:30	0.87
12/28/2023 21:00	-0.38	12/29/2023 10:00	-0.38	12/29/2023 23:00	-0.23	12/30/2023 12:00	-0.62	12/31/2023 1:00	0.26	12/31/2023 14:00	-0.36	1/11/2024 0:45	0.87
12/28/2023 21:15	-0.27	12/29/2023 10:15	-0.38	12/29/2023 23:15	-0.13	12/30/2023 12:15	-0.65	12/31/2023 1:15	0.30	12/31/2023 14:15	-0.37	1/11/2024 1:00	0.87
12/28/2023 21:30	-0.15	12/29/2023 10:30	-0.49	12/29/2023 23:30	-0.04	12/30/2023 12:30	-0.67	12/31/2023 1:30	0.33	12/31/2023 14:30	-0.42	1/11/2024 1:15	0.87
12/28/2023 21:45	-0.07	12/29/2023 10:45	-0.47	12/29/2023 23:45	0.00	12/30/2023 12:45	-0.70	12/31/2023 1:45	0.36	12/31/2023 14:45	-0.50	1/11/2024 1:30	0.88
12/28/2023 22:00	0.00	12/29/2023 11:00	-0.48	12/30/2023 0:00	0.05	12/30/2023 13:00	-0.77	12/31/2023 2:00	0.36	12/31/2023 15:00	-0.53	1/11/2024 1:45	0.92
12/28/2023 22:15	0.05	12/29/2023 11:15	-0.53	12/30/2023 0:15	0.10	12/30/2023 13:15	-0.79	12/31/2023 2:15	0.37	12/31/2023 15:15	-0.51	1/11/2024 2:00	0.92
12/28/2023 22:30	0.23	12/29/2023 11:30	-0.58	12/30/2023 0:30	0.14	12/30/2023 13:30	-0.83	12/31/2023 2:30	0.41	12/31/2023 15:30	-0.54	1/11/2024 2:15	0.94
12/28/2023 22:45	0.27	12/29/2023 11:45	-0.60	12/30/2023 0:45	0.17	12/30/2023 13:45	-0.85	12/31/2023 2:45	0.39	12/31/2023 15:45	-0.58	1/11/2024 2:30	0.95
12/28/2023 23:00	0.32	12/29/2023 12:00	-0.70	12/30/2023 1:00	0.18	12/30/2023 14:00	-0.93	12/31/2023 3:00	0.40	12/31/2023 16:00	-0.65	1/11/2024 2:45	0.97
12/28/2023 23:15	0.32	12/29/2023 12:15	-0.73	12/30/2023 1:15	0.19	12/30/2023 14:15	-0.99	12/31/2023 3:15	0.42	12/31/2023 16:15	-0.67	1/11/2024 3:00	0.99
12/28/2023 23:30	0.31	12/29/2023 12:30	-0.75	12/30/2023 1:30	0.19	12/30/2023 14:30	-1.02	12/31/2023 3:30	0.44	12/31/2023 16:30	-0.70	1/11/2024 3:15	1.00
12/28/2023 23:45	0.37	12/29/2023 12:45	-0.73	12/30/2023 1:45	0.19	12/30/2023 14:45	-1.07	12/31/2023 3:45	0.42	12/31/2023 16:45	-0.72	1/11/2024 3:30	1.03
12/29/2023 0:00	0.42	12/29/2023 13:00	-0.88	12/30/2023 2:00	0.26	12/30/2023 15:00	-1.13	12/31/2023 4:00	0.44	12/31/2023 17:00	-0.75	1/11/2024 3:45	1.07
12/29/2023 0:15	0.44	12/29/2023 13:15	-0.89	12/30/2023 2:15	0.23	12/30/2023 15:15	-1.14	12/31/2023 4:15	0.43	12/31/2023 17:15	-0.78	1/11/2024 4:00	1.08
12/29/2023 0:30	0.48	12/29/2023 13:30	-1.03	12/30/2023 2:30	0.29	12/30/2023 15:30	-1.15	12/31/2023 4:30	0.49	12/31/2023 17:30	-0.78	1/11/2024 4:15	1.10
12/29/2023 0:45	0.59	12/29/2023 13:45	-0.86	12/30/2023 2:45	0.21	12/30/2023 15:45	-1.19	12/31/2023 4:45	0.48	12/31/2023 17:45	-0.81	1/11/2024 4:30	1.12
12/29/2023 1:00	0.62	12/29/2023 14:00	-0.99	12/30/2023 3:00	0.15	12/30/2023 16:00	-1.28	12/31/2023 5:00	0.49	12/31/2023 18:00	-0.83	1/11/2024 4:45	1.13
12/29/2023 1:15	0.59	12/29/2023 14:15	-1.02	12/30/2023 3:15	0.14	12/30/2023 16:15	-1.26	12/31/2023 5:15	0.49	12/31/2023 18:15	-0.85	1/11/2024 5:00	1.14
12/29/2023 1:30	0.59	12/29/2023 14:30	-1.15	12/30/2023 3:30	0.12	12/30/2023 16:30	-1.27	12/31/2023 5:30	0.49	12/31/2023 18:30	-0.82	1/11/2024 5:15	1.17
12/29/2023 1:45	0.63	12/29/2023 14:45	-1.14	12/30/2023 3:45	0.13	12/30/2023 16:45	-1.30	12/31/2023 5:45	0.49	12/31/2023 18:45	-0.81	1/11/2024 5:30	1.17
12/29/2023 2:00	0.65	12/29/2023 15:00	-1.19	12/30/2023 4:00	0.12	12/30/2023 17:00	-1.35	12/31/2023 6:00	0.49	1/10/2024 17:06	-0.33	1/11/2024 5:45	1.20
12/29/2023 2:15	0.63	12/29/2023 15:15	-1.26	12/30/2023 4:15	0.08	12/30/2023 17:15	-1.35	12/31/2023 6:15	0.48	1/10/2024 17:15	-0.59	1/11/2024 6:00	1.22
12/29/2023 2:30	0.58	12/29/2023 15:30	-1.30	12/30/2023 4:30	0.05	12/30/2023 17:30	-1.34	12/31/2023 6:30	0.49	1/10/2024 17:24	-0.69	1/11/2024 6:15	1.23
12/29/2023 2:45	0.58	12/29/2023 15:45	-1.30	12/30/2023 4:45	0.01	12/30/2023 17:45	-1.35	12/31/2023 6:45	0.47	1/10/2024 17:30	-0.73	1/11/2024 6:30	1.24
12/29/2023 3:00	0.48	12/29/2023 16:00	-1.34	12/30/2023 5:00	0.01	12/30/2023 18:00	-1.33	12/31/2023 7:00	0.47	1/10/2024 17:45	-0.77	1/11/2024 6:45	1.25
12/29/2023 3:15	0.47	12/29/2023 16:15	-1.37	12/30/2023 5:15	0.00	12/30/2023 18:15	-1.31	12/31/2023 7:15	0.44	1/10/2024 18:00	-0.74	1/11/2024 7:00	1.22
12/29/2023 3:30	0.49	12/29/2023 16:30	-1.43	12/30/2023 5:30	-0.04	12/30/2023 18:30	-1.31	12/31/2023 7:30	0.44	1/10/2024 18:15	-0.69	1/11/2024 7:15	1.22
12/29/2023 3:45	0.46	12/29/2023 16:45	-1.44	12/30/2023 5:45	-0.09	12/30/2023 18:45	-1.27	12/31/2023 7:45	0.44	1/10/2024 18:30	-0.63	1/11/2024 7:30	1.18
12/29/2023 4:00	0.37	12/29/2023 17:00	-1.47	12/30/2023 6:00	-0.11	12/30/2023 19:00	-1.20	12/31/2023 8:00	0.41	1/10/2024 18:45	-0.52	1/11/2024 7:45	1.15
12/29/2023 4:15	0.36	12/29/2023 17:15	-1.50	12/30/2023 6:15	-0.14	12/30/2023 19:15	-1.16	12/31/2023 8:15	0.39	1/10/2024 19:00	-0.41	1/11/2024 8:00	1.11
12/29/2023 4:30	0.44	12/29/2023 17:30	-1.52	12/30/2023 6:30	-0.16	12/30/2023 19:30	-1.11	12/31/2023 8:30	0.38	1/10/2024 19:15	-0.36	1/11/2024 8:15	1.07
12/29/2023 4:45	0.42	12/29/2023 17:45	-1.51	12/30/2023 6:45	-0.17	12/30/2023 19:45	-1.06	12/31/2023 8:45	0.37	1/10/2024 19:30	-0.26	1/11/2024 8:30	1.02
12/29/2023 5:00	0.22	12/29/2023 18:00	-1.53	12/30/2023 7:00	-0.19	12/30/2023 20:00	-0.96	12/31/2023 9:00	0.35	1/10/2024 19:45	-0.18	1/11/2024 8:45	0.95
12/29/2023 5:15	0.28	12/29/2023 18:15	-1.52	12/30/2023 7:15	-0.23	12/30/2023 20:15	-0.92	12/31/2023 9:15	0.33	1/10/2024 20:00	-0.07	1/11/2024 9:00	0.94
12/29/2023 5:30	0.25	12/29/2023 18:30	-1.49	12/30/2023 7:30	-0.27	12/30/2023 20:30	-0.84	12/31/2023 9:30	0.31	1/10/2024 20:15	0.04	1/11/2024 9:15	0.86
12/29/2023 5:45	0.29	12/29/2023 18:45	-1.47	12/30/2023 7:45	-0.28	12/30/2023 20:45	-0.76	12/31/2023 9:45	0.29	1/10/2024 20:30	0.11	1/11/2024 9:30	0.77
12/29/2023 6:00	0.21	12/29/2023 19:00	-1.46	12/30/2023 8:00	-0.30	12/30/2023 21:00	-0.68	12/31/2023 10:00	0.25	1/10/2024 20:45	0.20	1/11/2024 9:45	0.73
12/29/2023 6:15	0.20	12/29/2023 19:15	-1.44	12/30/2023 8:15	-0.30	12/30/2023 21:15	-0.59	12/31/2023 10:15	0.22	1/10/2024 21:00	0.28	1/11/2024 10:00	0.66
12/29/2023 6:30	0.15	12/29/2023 19:30	-1.35	12/30/2023 8:30	-0.33	12/30/2023 21:30	-0.52	12/31/2023 10:30	0.20	1/10/2024 21:15	0.34	1/11/2024 10:15	0.59
12/29/2023 6:45	0.11	12/29/2023 19:45	-1.26	12/30/2023 8:45	-0.35	12/30/2023 21:45	-0.42	12/31/2023 10:45	0.16	1/10/2024 21:30	0.41	1/11/2024 10:30	0.52
12/29/2023 7:00	0.05	12/29/2023 20:00	-1.20	12/30/2023 9:00	-0.41	12/30/2023 22:00	-0.35	12/31/2023 11:00	0.14	1/10/2024 21:45	0.48	1/11/2024 10:45	0.46
12/29/2023 7:15	0.08	12/29/2023 20:15	-1.11	12/30/2023 9:15	-0.43	12/30/2023 22:15	-0.29	12/31/2023 11:15	0.09	1/10/2024 22:00	0.53	1/11/2024 11:00	0.38

Date & Time	Water Level (ft)	Date & Time	Water Level (ft)	Date & Time	Water Level (ft)	Date & Time	Water Level (ft)	Date & Time	Water Level (ft)	Date & Time	Water Level (ft)	Date & Time	Water Level (ft)
1/11/2024 11:15	0.30	1/12/2024 0:15	1.64	1/12/2024 13:15	-0.48	1/13/2024 2:15	-0.23	1/13/2024 15:15	-0.83	1/14/2024 4:15	1.12	1/14/2024 17:15	-0.52
1/11/2024 11:30	0.23	1/12/2024 0:30	1.64	1/12/2024 13:30	-0.70	1/13/2024 2:30	-0.23	1/13/2024 15:30	-0.90	1/14/2024 4:30	1.16	1/14/2024 17:30	-0.61
1/11/2024 11:45	0.16	1/12/2024 0:45	1.69	1/12/2024 13:45	-0.76	1/13/2024 2:45	-0.22	1/13/2024 15:45	-0.92	1/14/2024 4:45	1.12	1/14/2024 17:45	-0.65
1/11/2024 12:00	0.07	1/12/2024 1:00	1.65	1/12/2024 14:00	-0.77	1/13/2024 3:00	-0.23	1/13/2024 16:00	-0.96	1/14/2024 5:00	1.13	1/14/2024 18:00	-0.68
1/11/2024 12:15	0.03	1/12/2024 1:15	1.65	1/12/2024 14:15	-0.85	1/13/2024 3:15	-0.22	1/13/2024 16:15	-0.99	1/14/2024 5:15	1.13	1/14/2024 18:15	-0.71
1/11/2024 12:30	-0.03	1/12/2024 1:30	1.69	1/12/2024 14:30	-0.93	1/13/2024 3:30	-0.22	1/13/2024 16:30	-1.01	1/14/2024 5:30	1.13	1/14/2024 18:30	-0.75
1/11/2024 12:45	-0.10	1/12/2024 1:45	1.68	1/12/2024 14:45	-0.94	1/13/2024 3:45	-0.20	1/13/2024 16:45	-1.03	1/14/2024 5:45	1.13	1/14/2024 18:45	-0.75
1/11/2024 13:00	-0.18	1/12/2024 2:00	1.71	1/12/2024 15:00	-0.97	1/13/2024 4:00	-0.21	1/13/2024 17:00	-1.04	1/14/2024 6:00	1.16	1/14/2024 19:00	-0.79
1/11/2024 13:15	-0.25	1/12/2024 2:15	1.75	1/12/2024 15:15	-1.02	1/13/2024 4:15	-0.19	1/13/2024 17:15	-1.04	1/14/2024 6:15	1.17	1/14/2024 19:15	-0.84
1/11/2024 13:30	-0.26	1/12/2024 2:30	1.76	1/12/2024 15:30	-1.02	1/13/2024 4:30	-0.18	1/13/2024 17:30	-1.05	1/14/2024 6:30	1.15	1/14/2024 19:30	-0.83
1/11/2024 13:45	-0.31	1/12/2024 2:45	1.79	1/12/2024 15:45	-1.09	1/13/2024 4:45	-0.20	1/13/2024 17:45	-1.02	1/14/2024 6:45	1.17	1/14/2024 19:45	-0.78
1/11/2024 14:00	-0.31	1/12/2024 3:00	1.81	1/12/2024 16:00	-1.14	1/13/2024 5:00	-0.18	1/13/2024 18:00	-0.98	1/14/2024 7:00	1.20	1/14/2024 20:00	-0.77
1/11/2024 14:15	-0.36	1/12/2024 3:15	1.85	1/12/2024 16:15	-1.20	1/13/2024 5:15	-0.17	1/13/2024 18:15	-0.97	1/14/2024 7:15	1.19	1/14/2024 20:15	-0.75
1/11/2024 14:30	-0.41	1/12/2024 3:30	1.88	1/12/2024 16:30	-1.24	1/13/2024 5:30	-0.18	1/13/2024 18:30	-0.91	1/14/2024 7:30	1.16	1/14/2024 20:30	-0.71
1/11/2024 14:45	-0.44	1/12/2024 3:45	1.87	1/12/2024 16:45	-1.22	1/13/2024 5:45	-0.18	1/13/2024 18:45	-0.85	1/14/2024 7:45	1.24	1/14/2024 20:45	-0.69
1/11/2024 15:00	-0.41	1/12/2024 4:00	1.86	1/12/2024 17:00	-1.27	1/13/2024 6:00	-0.15	1/13/2024 19:00	-0.80	1/14/2024 8:00	1.11	1/14/2024 21:00	-0.63
1/11/2024 15:15	-0.48	1/12/2024 4:15	1.92	1/12/2024 17:15	-1.33	1/13/2024 6:15	-0.14	1/13/2024 19:15	-0.74	1/14/2024 8:15	1.13	1/14/2024 21:15	-0.62
1/11/2024 15:30	-0.52	1/12/2024 4:30	2.00	1/12/2024 17:30	-1.38	1/13/2024 6:30	-0.13	1/13/2024 19:30	-0.68	1/14/2024 8:30	1.24	1/14/2024 21:30	-0.58
1/11/2024 15:45	-0.54	1/12/2024 4:45	2.06	1/12/2024 17:45	-1.40	1/13/2024 6:45	-0.11	1/13/2024 19:45	-0.60	1/14/2024 8:45	1.25	1/14/2024 21:45	-0.49
1/11/2024 16:00	-0.53	1/12/2024 5:00	2.15	1/12/2024 18:00	-1.43	1/13/2024 7:00	-0.07	1/13/2024 20:00	-0.52	1/14/2024 9:00	1.27	1/14/2024 22:00	-0.45
1/11/2024 16:15	-0.55	1/12/2024 5:15	2.09	1/12/2024 18:15	-1.47	1/13/2024 7:15	-0.02	1/13/2024 20:15	-0.44	1/14/2024 9:15	1.18	1/14/2024 22:15	-0.40
1/11/2024 16:30	-0.56	1/12/2024 5:30	2.15	1/12/2024 18:30	-1.52	1/13/2024 7:30	0.00	1/13/2024 20:30	-0.35	1/14/2024 9:30	1.21	1/14/2024 22:30	-0.32
1/11/2024 16:45	-0.51	1/12/2024 5:45	2.20	1/12/2024 18:45	-1.52	1/13/2024 7:45	0.06	1/13/2024 20:45	-0.26	1/14/2024 9:45	1.17	1/14/2024 22:45	-0.28
1/11/2024 17:00	-0.51	1/12/2024 6:00	2.05	1/12/2024 19:00	-1.53	1/13/2024 8:00	0.07	1/13/2024 21:00	-0.16	1/14/2024 10:00	1.14	1/14/2024 23:00	-0.19
1/11/2024 17:15	-0.42	1/12/2024 6:15	2.59	1/12/2024 19:15	-1.53	1/13/2024 8:15	0.08	1/13/2024 21:15	-0.05	1/14/2024 10:15	1.10	1/14/2024 23:15	-0.09
1/11/2024 17:30	-0.34	1/12/2024 6:30	2.28	1/12/2024 19:30	-1.54	1/13/2024 8:30	0.11	1/13/2024 21:30	0.05	1/14/2024 10:30	1.08	1/14/2024 23:30	-0.02
1/11/2024 17:45	-0.26	1/12/2024 6:45	2.13	1/12/2024 19:45	-1.52	1/13/2024 8:45	0.13	1/13/2024 21:45	0.17	1/14/2024 10:45	1.05	1/14/2024 23:45	0.06
1/11/2024 18:00	-0.18	1/12/2024 7:00	1.96	1/12/2024 20:00	-1.51	1/13/2024 9:00	0.13	1/13/2024 22:00	0.28	1/14/2024 11:00	1.00	1/15/2024 0:00	0.09
1/11/2024 18:15	-0.09	1/12/2024 7:15	1.96	1/12/2024 20:15	-1.52	1/13/2024 9:15	0.10	1/13/2024 22:15	0.37	1/14/2024 11:15	0.99	1/15/2024 0:15	0.17
1/11/2024 18:30	-0.03	1/12/2024 7:30	1.76	1/12/2024 20:30	-1.52	1/13/2024 9:30	0.12	1/13/2024 22:30	0.46	1/14/2024 11:30	0.92	1/15/2024 0:30	0.24
1/11/2024 18:45	0.09	1/12/2024 7:45	1.85	1/12/2024 20:45	-1.51	1/13/2024 9:45	0.17	1/13/2024 22:45	0.53	1/14/2024 11:45	0.89	1/15/2024 0:45	0.26
1/11/2024 19:00	0.18	1/12/2024 8:00	1.63	1/12/2024 21:00	-1.47	1/13/2024 10:00	0.16	1/13/2024 23:00	0.60	1/14/2024 12:00	0.76	1/15/2024 1:00	0.38
1/11/2024 19:15	0.24	1/12/2024 8:15	1.64	1/12/2024 21:15	-1.42	1/13/2024 10:15	0.16	1/13/2024 23:15	0.68	1/14/2024 12:15	0.75	1/15/2024 1:15	0.40
1/11/2024 19:30	0.38	1/12/2024 8:30	1.48	1/12/2024 21:30	-1.37	1/13/2024 10:30	0.11	1/13/2024 23:30	0.75	1/14/2024 12:30	0.67	1/15/2024 1:30	0.35
1/11/2024 19:45	0.46	1/12/2024 8:45	1.52	1/12/2024 21:45	-1.31	1/13/2024 10:45	0.05	1/13/2024 23:45	0.80	1/14/2024 12:45	0.65	1/15/2024 1:45	0.34
1/11/2024 20:00	0.55	1/12/2024 9:00	1.44	1/12/2024 22:00	-1.20	1/13/2024 11:00	0.01	1/14/2024 0:00	0.85	1/14/2024 13:00	0.59	1/15/2024 2:00	0.37
1/11/2024 20:15	0.69	1/12/2024 9:15	1.09	1/12/2024 22:15	-1.13	1/13/2024 11:15	-0.03	1/14/2024 0:15	0.89	1/14/2024 13:15	0.51	1/15/2024 2:15	0.22
1/11/2024 20:30	0.78	1/12/2024 9:30	1.26	1/12/2024 22:30	-1.09	1/13/2024 11:30	-0.06	1/14/2024 0:30	0.95	1/14/2024 13:30	0.36	1/15/2024 2:30	0.32
1/11/2024 20:45	0.87	1/12/2024 9:45	1.13	1/12/2024 22:45	-1.01	1/13/2024 11:45	-0.10	1/14/2024 0:45	0.97	1/14/2024 13:45	0.30	1/15/2024 2:45	0.32
1/11/2024 21:00	1.00	1/12/2024 10:00	1.04	1/12/2024 23:00	-0.94	1/13/2024 12:00	-0.14	1/14/2024 1:00	1.01	1/14/2024 14:00	0.21	1/15/2024 3:00	0.35
1/11/2024 21:15	1.09	1/12/2024 10:15	0.84	1/12/2024 23:15	-0.90	1/13/2024 12:15	-0.20	1/14/2024 1:15	1.04	1/14/2024 14:15	0.12	1/15/2024 3:15	0.23
1/11/2024 21:30	1.17	1/12/2024 10:30	0.86	1/12/2024 23:30	-0.82	1/13/2024 12:30	-0.29	1/14/2024 1:30	1.05	1/14/2024 14:30	0.09	1/15/2024 3:30	0.13
1/11/2024 21:45	1.26	1/12/2024 10:45	0.78	1/12/2024 23:45	-0.74	1/13/2024 12:45	-0.31	1/14/2024 1:45	1.09	1/14/2024 14:45	-0.02	1/15/2024 3:45	0.21
1/11/2024 22:00	1.29	1/12/2024 11:00	0.53	1/13/2024 0:00	-0.66	1/13/2024 13:00	-0.38	1/14/2024 2:00	1.12	1/14/2024 15:00	-0.09	1/15/2024 4:00	0.12
1/11/2024 22:15	1.32	1/12/2024 11:15	0.53	1/13/2024 0:15	-0.60	1/13/2024 13:15	-0.45	1/14/2024 2:15	1.14	1/14/2024 15:15	-0.10	1/15/2024 4:15	0.15
1/11/2024 22:30	1.38	1/12/2024 11:30	0.42	1/13/2024 0:30	-0.52	1/13/2024 13:30	-0.49	1/14/2024 2:30	1.15	1/14/2024 15:30	-0.22	1/15/2024 4:30	0.05
1/11/2024 22:45	1.41	1/12/2024 11:45	0.43	1/13/2024 0:45	-0.48	1/13/2024 13:45	-0.56	1/14/2024 2:45	1.13	1/14/2024 15:45	-0.26	1/15/2024 4:45	0.00
1/11/2024 23:00	1.48	1/12/2024 12:00	0.27	1/13/2024 1:00	-0.42	1/13/2024 14:00	-0.60	1/14/2024 3:00	1.14	1/14/2024 16:00	-0.30	1/15/2024 5:00	0.01
1/11/2024 23:15	1.51	1/12/2024 12:15	0.09	1/13/2024 1:15	-0.36	1/13/2024 14:15	-0.64	1/14/2024 3:15	1.14	1/14/2024 16:15	-0.35	1/15/2024 5:15	-0.06
1/11/2024 23:30	1.55	1/12/2024 12:30	-0.02	1/13/2024 1:30	-0.31	1/13/2024 14:30	-0.71	1/14/2024 3:30	1.13	1/14/2024 16:30	-0.39	1/15/2024 5:30	-0.02
1/11/2024 23:45	1.57	1/12/2024 12:45	-0.12	1/13/2024 1:45	-0.27	1/13/2024 14:45	-0.74	1/14/2024 3:45	1.13	1/14/2024 16:45	-0.43	1/15/2024 5:45	-0.07
1/12/2024 0:00	1.61	1/12/2024 13:00	-0.35	1/13/2024 2:00	-0.25	1/13/2024 15:00	-0.80	1/14/2024 4:00	1.14	1/14/2024 17:00	-0.49	1/15/2024 6:00	-0.08

Date & Time	Water Level (ft)	Date & Time	Water Level (ft)	Date & Time	Water Level (ft)	Date & Time	Water Level (ft)	Date & Time	Water Level (ft)	Date & Time	Water Level (ft)	Date & Time	Water Level (ft)
1/15/2024 6:15	-0.20	1/15/2024 19:15	-1.22	1/16/2024 8:15	-0.28	1/16/2024 21:15	-1.21	1/17/2024 10:15	-0.46	1/17/2024 23:15	0.62	1/18/2024 12:15	0.06
1/15/2024 6:30	-0.08	1/15/2024 19:30	-1.24	1/16/2024 8:30	-0.03	1/16/2024 21:30	-1.24	1/17/2024 10:30	-0.41	1/17/2024 23:30	0.68	1/18/2024 12:30	0.08
1/15/2024 6:45	-0.26	1/15/2024 19:45	-1.25	1/16/2024 8:45	-0.43	1/16/2024 21:45	-1.12	1/17/2024 10:45	-0.33	1/17/2024 23:45	0.67	1/18/2024 12:45	0.15
1/15/2024 7:00	-0.17	1/15/2024 20:00	-1.23	1/16/2024 9:00	-0.36	1/16/2024 22:00	-1.12	1/17/2024 11:00	-0.23	1/18/2024 0:00	0.74	1/18/2024 13:00	0.21
1/15/2024 7:15	-0.17	1/15/2024 20:15	-1.17	1/16/2024 9:15	-0.51	1/16/2024 22:15	-1.02	1/17/2024 11:15	-0.19	1/18/2024 0:15	0.82	1/18/2024 13:15	0.29
1/15/2024 7:30	-0.19	1/15/2024 20:30	-1.15	1/16/2024 9:30	-0.58	1/16/2024 22:30	-0.87	1/17/2024 11:30	-0.14	1/18/2024 0:30	0.85	1/18/2024 13:30	0.34
1/15/2024 7:45	-0.12	1/15/2024 20:45	-1.05	1/16/2024 9:45	-0.73	1/16/2024 22:45	-0.76	1/17/2024 11:45	-0.07	1/18/2024 0:45	0.87	1/18/2024 13:45	0.39
1/15/2024 8:00	-0.10	1/15/2024 21:00	-1.11	1/16/2024 10:00	-0.77	1/16/2024 23:00	-0.64	1/17/2024 12:00	0.00	1/18/2024 1:00	0.92	1/18/2024 14:00	0.47
1/15/2024 8:15	-0.22	1/15/2024 21:15	-1.13	1/16/2024 10:15	-1.05	1/16/2024 23:15	-0.51	1/17/2024 12:15	0.06	1/18/2024 1:15	0.97	1/18/2024 14:15	0.52
1/15/2024 8:30	-0.19	1/15/2024 21:30	-1.19	1/16/2024 10:30	-1.38	1/16/2024 23:30	-0.54	1/17/2024 12:30	0.15	1/18/2024 1:30	0.99	1/18/2024 14:30	0.57
1/15/2024 8:45	-0.15	1/15/2024 21:45	-1.04	1/16/2024 10:45	-1.36	1/16/2024 23:45	-0.24	1/17/2024 12:45	0.18	1/18/2024 1:45	1.01	1/18/2024 14:45	0.61
1/15/2024 9:00	-0.15	1/15/2024 22:00	-1.10	1/16/2024 11:00	-1.54	1/17/2024 0:00	-0.27	1/17/2024 13:00	0.23	1/18/2024 2:00	1.03	1/18/2024 15:00	0.69
1/15/2024 9:15	-0.13	1/15/2024 22:15	-1.04	1/16/2024 11:15	-1.64	1/17/2024 0:15	0.32	1/17/2024 13:15	0.27	1/18/2024 2:15	1.07	1/18/2024 15:15	0.74
1/15/2024 9:30	-0.12	1/15/2024 22:30	-1.02	1/16/2024 11:30	-1.65	1/17/2024 0:30	0.20	1/17/2024 13:30	0.31	1/18/2024 2:30	1.08	1/18/2024 15:30	0.81
1/15/2024 9:45	-0.05	1/15/2024 22:45	-1.09	1/16/2024 11:45	-1.44	1/17/2024 0:45	0.36	1/17/2024 13:45	0.37	1/18/2024 2:45	1.11	1/18/2024 15:45	0.87
1/15/2024 10:00	-0.15	1/15/2024 23:00	-0.94	1/16/2024 12:00	-1.71	1/17/2024 1:00	0.22	1/17/2024 14:00	0.39	1/18/2024 3:00	1.10	1/18/2024 16:00	0.93
1/15/2024 10:15	-0.13	1/15/2024 23:15	-1.04	1/16/2024 12:15	-1.65	1/17/2024 1:15	0.41	1/17/2024 14:15	0.44	1/18/2024 3:15	1.05	1/18/2024 16:15	1.00
1/15/2024 10:30	-0.08	1/15/2024 23:30	-0.84	1/16/2024 12:30	-1.56	1/17/2024 1:30	0.74	1/17/2024 14:30	0.52	1/18/2024 3:30	1.05	1/18/2024 16:30	1.00
1/15/2024 10:45	0.04	1/15/2024 23:45	-0.95	1/16/2024 12:45	-1.58	1/17/2024 1:45	0.42	1/17/2024 14:45	0.57	1/18/2024 3:45	1.03	1/18/2024 16:45	1.07
1/15/2024 11:00	0.00	1/16/2024 0:00	-0.90	1/16/2024 13:00	-1.59	1/17/2024 2:00	0.82	1/17/2024 15:00	0.63	1/18/2024 4:00	0.97	1/18/2024 17:00	1.07
1/15/2024 11:15	-0.03	1/16/2024 0:15	-0.80	1/16/2024 13:15	-1.58	1/17/2024 2:15	0.29	1/17/2024 15:15	0.63	1/18/2024 4:15	0.94	1/18/2024 17:15	1.05
1/15/2024 11:30	-0.02	1/16/2024 0:30	-0.93	1/16/2024 13:30	-1.59	1/17/2024 2:30	0.46	1/17/2024 15:30	0.59	1/18/2024 4:30	0.91	1/18/2024 17:30	1.11
1/15/2024 11:45	0.03	1/16/2024 0:45	-0.82	1/16/2024 13:45	-1.52	1/17/2024 2:45	0.53	1/17/2024 15:45	0.61	1/18/2024 4:45	0.85	1/18/2024 17:45	1.12
1/15/2024 12:00	-0.02	1/16/2024 1:00	-0.89	1/16/2024 14:00	-1.51	1/17/2024 3:00	0.93	1/17/2024 16:00	0.57	1/18/2024 5:00	0.83	1/18/2024 18:00	1.16
1/15/2024 12:15	0.05	1/16/2024 1:15	-0.79	1/16/2024 14:15	-1.54	1/17/2024 3:15	0.87	1/17/2024 16:15	0.68	1/18/2024 5:15	0.78	1/18/2024 18:15	1.17
1/15/2024 12:30	0.03	1/16/2024 1:30	-0.57	1/16/2024 14:30	-1.42	1/17/2024 3:30	1.05	1/17/2024 16:30	0.70	1/18/2024 5:30	0.73	1/18/2024 18:30	1.17
1/15/2024 12:45	0.06	1/16/2024 1:45	-0.70	1/16/2024 14:45	-1.46	1/17/2024 3:45	0.72	1/17/2024 16:45	0.71	1/18/2024 5:45	0.66	1/18/2024 18:45	1.12
1/15/2024 13:00	-0.05	1/16/2024 2:00	-0.73	1/16/2024 15:00	-1.51	1/17/2024 4:00	0.69	1/17/2024 17:00	0.67	1/18/2024 6:00	0.59	1/18/2024 19:00	1.11
1/15/2024 13:15	-0.16	1/16/2024 2:15	-0.77	1/16/2024 15:15	-1.49	1/17/2024 4:15	0.74	1/17/2024 17:15	0.72	1/18/2024 6:15	0.53	1/18/2024 19:15	1.12
1/15/2024 13:30	-0.27	1/16/2024 2:30	-0.65	1/16/2024 15:30	-1.44	1/17/2024 4:30	0.87	1/17/2024 17:30	0.64	1/18/2024 6:30	0.47	1/18/2024 19:30	1.05
1/15/2024 13:45	-0.13	1/16/2024 2:45	-0.90	1/16/2024 15:45	-1.48	1/17/2024 4:45	0.57	1/17/2024 17:45	0.67	1/18/2024 6:45	0.36	1/18/2024 19:45	1.06
1/15/2024 14:00	-0.21	1/16/2024 3:00	-0.64	1/16/2024 16:00	-1.45	1/17/2024 5:00	0.94	1/17/2024 18:00	0.64	1/18/2024 7:00	0.34	1/18/2024 20:00	1.03
1/15/2024 14:15	-0.23	1/16/2024 3:15	-0.73	1/16/2024 16:15	-1.49	1/17/2024 5:15	0.88	1/17/2024 18:15	0.67	1/18/2024 7:15	0.32	1/18/2024 20:15	0.98
1/15/2024 14:30	-0.34	1/16/2024 3:30	-0.89	1/16/2024 16:30	-1.52	1/17/2024 5:30	0.80	1/17/2024 18:30	0.68	1/18/2024 7:30	0.24	1/18/2024 20:30	0.98
1/15/2024 14:45	-0.35	1/16/2024 3:45	-0.69	1/16/2024 16:45	-1.49	1/17/2024 5:45	1.33	1/17/2024 18:45	0.70	1/18/2024 7:45	0.17	1/18/2024 20:45	0.97
1/15/2024 15:00	-0.39	1/16/2024 4:00	-0.77	1/16/2024 17:00	-1.41	1/17/2024 6:00	0.80	1/17/2024 19:00	0.69	1/18/2024 8:00	0.14	1/18/2024 21:00	0.89
1/15/2024 15:15	-0.50	1/16/2024 4:15	-0.85	1/16/2024 17:15	-1.45	1/17/2024 6:15	0.82	1/17/2024 19:15	0.74	1/18/2024 8:15	0.09	1/18/2024 21:15	0.91
1/15/2024 15:30	-0.52	1/16/2024 4:30	-0.67	1/16/2024 17:30	-1.41	1/17/2024 6:30	0.94	1/17/2024 19:30	0.67	1/18/2024 8:30	0.06	1/18/2024 21:30	0.85
1/15/2024 15:45	-0.59	1/16/2024 4:45	-0.68	1/16/2024 17:45	-1.40	1/17/2024 6:45	0.95	1/17/2024 19:45	0.66	1/18/2024 8:45	0.01	1/18/2024 21:45	0.82
1/15/2024 16:00	-0.67	1/16/2024 5:00	-0.48	1/16/2024 18:00	-1.44	1/17/2024 7:00	0.95	1/17/2024 20:00	0.60	1/18/2024 9:00	0.00	1/18/2024 22:00	0.76
1/15/2024 16:15	-0.68	1/16/2024 5:15	-0.61	1/16/2024 18:15	-1.46	1/17/2024 7:15	1.07	1/17/2024 20:15	0.62	1/18/2024 9:15	-0.02	1/18/2024 22:15	0.72
1/15/2024 16:30	-0.73	1/16/2024 5:30	-0.40	1/16/2024 18:30	-1.44	1/17/2024 7:30	1.26	1/17/2024 20:30	0.54	1/18/2024 9:30	-0.03	1/18/2024 22:30	0.70
1/15/2024 16:45	-0.83	1/16/2024 5:45	-0.86	1/16/2024 18:45	-1.45	1/17/2024 7:45	1.45	1/17/2024 20:45	0.53	1/18/2024 9:45	-0.06	1/18/2024 22:45	0.66
1/15/2024 17:00	-0.90	1/16/2024 6:00	-0.58	1/16/2024 19:00	-1.53	1/17/2024 8:00	1.28	1/17/2024 21:00	0.54	1/18/2024 10:00	-0.10	1/18/2024 23:00	0.63
1/15/2024 17:15	-0.94	1/16/2024 6:15	-0.65	1/16/2024 19:15	-1.50	1/17/2024 8:15	1.18	1/17/2024 21:15	0.51	1/18/2024 10:15	-0.11	1/18/2024 23:15	0.60
1/15/2024 17:30	-0.98	1/16/2024 6:30	-0.77	1/16/2024 19:30	-1.47	1/17/2024 8:30	1.33	1/17/2024 21:30	0.55	1/18/2024 10:30	-0.11	1/18/2024 23:30	0.59
1/15/2024 17:45	-0.93	1/16/2024 6:45	-0.48	1/16/2024 19:45	-1.41	1/17/2024 8:45	1.06	1/17/2024 21:45	0.50	1/18/2024 10:45	-0.08	1/18/2024 23:45	0.55
1/15/2024 18:00	-0.97	1/16/2024 7:00	-0.50	1/16/2024 20:00	-1.37	1/17/2024 9:00	0.40	1/17/2024 22:00	0.56	1/18/2024 11:00	-0.11	1/19/2024 0:00	0.54
1/15/2024 18:15	-1.00	1/16/2024 7:15	-0.49	1/16/2024 20:15	-1.33	1/17/2024 9:15	-0.02	1/17/2024 22:15	0.51	1/18/2024 11:15	-0.07	1/19/2024 0:15	0.52
1/15/2024 18:30	-1.12	1/16/2024 7:30	-0.49	1/16/2024 20:30	-1.35	1/17/2024 9:30	-0.08	1/17/2024 22:30	0.58	1/18/2024 11:30	-0.07	1/19/2024 0:30	0.49
1/15/2024 18:45	-1.07	1/16/2024 7:45	-0.19	1/16/2024 20:45	-1.34	1/17/2024 9:45	-0.41	1/17/2024 22:45	0.64	1/18/2024 11:45	-0.05	1/19/2024 0:45	0.46
1/15/2024 19:00	-1.14	1/16/2024 8:00	-0.56	1/16/2024 21:00	-1.26	1/17/2024 10:00	-0.40	1/17/2024 23:00	0.61	1/18/2024 12:00	0.00	1/19/2024 1:00	0.45

Date & Time	Water Level (ft)	Date & Time	Water Level (ft)	Date & Time	Water Level (ft)	Date & Time	Water Level (ft)	Date & Time	Water Level (ft)	Date & Time	Water Level (ft)	Date & Time	Water Level (ft)
1/19/2024 1:15	0.44	1/19/2024 14:15	-0.96	1/20/2024 3:15	-0.37	1/20/2024 16:15	-0.57	1/21/2024 5:15	0.54	1/21/2024 18:15	0.98	1/22/2024 7:15	1.92
1/19/2024 1:30	0.43	1/19/2024 14:30	-0.97	1/20/2024 3:30	-0.42	1/20/2024 16:30	-0.48	1/21/2024 5:30	0.63	1/21/2024 18:30	1.11	1/22/2024 7:30	1.83
1/19/2024 1:45	0.43	1/19/2024 14:45	-0.90	1/20/2024 3:45	-0.52	1/20/2024 16:45	-0.43	1/21/2024 5:45	0.58	1/21/2024 18:45	1.20	1/22/2024 7:45	1.77
1/19/2024 2:00	0.43	1/19/2024 15:00	-0.96	1/20/2024 4:00	-0.51	1/20/2024 17:00	-0.24	1/21/2024 6:00	0.62	1/21/2024 19:00	1.26	1/22/2024 8:00	1.60
1/19/2024 2:15	0.42	1/19/2024 15:15	-0.86	1/20/2024 4:15	-0.57	1/20/2024 17:15	-0.20	1/21/2024 6:15	0.56	1/21/2024 19:15	1.27	1/22/2024 8:15	1.55
1/19/2024 2:30	0.41	1/19/2024 15:30	-0.86	1/20/2024 4:30	-0.61	1/20/2024 17:30	-0.14	1/21/2024 6:30	0.55	1/21/2024 19:30	1.32	1/22/2024 8:30	1.44
1/19/2024 2:45	0.42	1/19/2024 15:45	-0.79	1/20/2024 4:45	-0.65	1/20/2024 17:45	-0.04	1/21/2024 6:45	0.53	1/21/2024 19:45	1.35	1/22/2024 8:45	1.36
1/19/2024 3:00	0.36	1/19/2024 16:00	-0.71	1/20/2024 5:00	-0.68	1/20/2024 18:00	-0.02	1/21/2024 7:00	0.50	1/21/2024 20:00	1.46	1/22/2024 9:00	1.25
1/19/2024 3:15	0.39	1/19/2024 16:15	-0.70	1/20/2024 5:15	-0.75	1/20/2024 18:15	0.06	1/21/2024 7:15	0.36	1/21/2024 20:15	1.44	1/22/2024 9:15	1.11
1/19/2024 3:30	0.36	1/19/2024 16:30	-0.69	1/20/2024 5:30	-0.76	1/20/2024 18:30	0.06	1/21/2024 7:30	0.40	1/21/2024 20:30	1.42	1/22/2024 9:30	1.10
1/19/2024 3:45	0.32	1/19/2024 16:45	-0.49	1/20/2024 5:45	-0.85	1/20/2024 18:45	0.17	1/21/2024 7:45	0.35	1/21/2024 20:45	1.54	1/22/2024 9:45	0.97
1/19/2024 4:00	0.25	1/19/2024 17:00	-0.41	1/20/2024 6:00	-0.86	1/20/2024 19:00	0.23	1/21/2024 8:00	0.33	1/21/2024 21:00	1.53	1/22/2024 10:00	0.97
1/19/2024 4:15	0.26	1/19/2024 17:15	-0.43	1/20/2024 6:15	-0.97	1/20/2024 19:15	0.29	1/21/2024 8:15	0.35	1/21/2024 21:15	1.53	1/22/2024 10:15	1.00
1/19/2024 4:30	0.19	1/19/2024 17:30	-0.42	1/20/2024 6:30	-0.98	1/20/2024 19:30	0.34	1/21/2024 8:30	0.21	1/21/2024 21:30	1.51	1/22/2024 10:30	0.90
1/19/2024 4:45	0.16	1/19/2024 17:45	-0.26	1/20/2024 6:45	-1.05	1/20/2024 19:45	0.38	1/21/2024 8:45	0.14	1/21/2024 21:45	1.56	1/22/2024 10:45	0.89
1/19/2024 5:00	0.15	1/19/2024 18:00	-0.31	1/20/2024 7:00	-0.98	1/20/2024 20:00	0.47	1/21/2024 9:00	0.10	1/21/2024 22:00	1.59	1/22/2024 11:00	0.82
1/19/2024 5:15	0.07	1/19/2024 18:15	-0.19	1/20/2024 7:15	-1.03	1/20/2024 20:15	0.50	1/21/2024 9:15	-0.01	1/21/2024 22:15	1.53	1/22/2024 11:15	0.75
1/19/2024 5:30	0.03	1/19/2024 18:30	-0.27	1/20/2024 7:30	-1.10	1/20/2024 20:30	0.53	1/21/2024 9:30	0.01	1/21/2024 22:30	1.55	1/22/2024 11:30	0.79
1/19/2024 5:45	-0.05	1/19/2024 18:45	-0.09	1/20/2024 7:45	-1.12	1/20/2024 20:45	0.56	1/21/2024 9:45	-0.12	1/21/2024 22:45	1.59	1/22/2024 11:45	0.80
1/19/2024 6:00	-0.10	1/19/2024 19:00	-0.17	1/20/2024 8:00	-1.13	1/20/2024 21:00	0.61	1/21/2024 10:00	-0.17	1/21/2024 23:00	1.61	1/22/2024 12:00	0.65
1/19/2024 6:15	-0.09	1/19/2024 19:15	-0.11	1/20/2024 8:15	-1.15	1/20/2024 21:15	0.60	1/21/2024 10:15	-0.17	1/21/2024 23:15	1.66	1/22/2024 12:15	0.88
1/19/2024 6:30	-0.19	1/19/2024 19:30	-0.16	1/20/2024 8:30	-1.16	1/20/2024 21:30	0.64	1/21/2024 10:30	-0.17	1/21/2024 23:30	1.68	1/22/2024 12:30	0.72
1/19/2024 6:45	-0.21	1/19/2024 19:45	-0.06	1/20/2024 8:45	-1.22	1/20/2024 21:45	0.69	1/21/2024 10:45	-0.20	1/21/2024 23:45	1.70	1/22/2024 12:45	0.76
1/19/2024 7:00	-0.31	1/19/2024 20:00	-0.04	1/20/2024 9:00	-1.25	1/20/2024 22:00	0.60	1/21/2024 11:00	-0.27	1/22/2024 0:00	1.73	1/22/2024 13:00	0.76
1/19/2024 7:15	-0.32	1/19/2024 20:15	0.03	1/20/2024 9:15	-1.28	1/20/2024 22:15	0.70	1/21/2024 11:15	-0.26	1/22/2024 0:15	1.72	1/22/2024 13:15	0.74
1/19/2024 7:30	-0.36	1/19/2024 20:30	-0.03	1/20/2024 9:30	-1.32	1/20/2024 22:30	0.72	1/21/2024 11:30	-0.23	1/22/2024 0:30	1.73	1/22/2024 13:30	0.68
1/19/2024 7:45	-0.44	1/19/2024 20:45	-0.01	1/20/2024 9:45	-1.31	1/20/2024 22:45	0.68	1/21/2024 11:45	-0.25	1/22/2024 0:45	1.64	1/22/2024 13:45	0.60
1/19/2024 8:00	-0.53	1/19/2024 21:00	0.10	1/20/2024 10:00	-1.34	1/20/2024 23:00	0.80	1/21/2024 12:00	-0.32	1/22/2024 1:00	1.74	1/22/2024 14:00	0.63
1/19/2024 8:15	-0.61	1/19/2024 21:15	0.13	1/20/2024 10:15	-1.35	1/20/2024 23:15	0.71	1/21/2024 12:15	-0.33	1/22/2024 1:15	1.76	1/22/2024 14:15	0.64
1/19/2024 8:30	-0.68	1/19/2024 21:30	0.06	1/20/2024 10:30	-1.39	1/20/2024 23:30	0.70	1/21/2024 12:30	-0.20	1/22/2024 1:30	1.77	1/22/2024 14:30	0.58
1/19/2024 8:45	-0.69	1/19/2024 21:45	0.04	1/20/2024 10:45	-1.47	1/20/2024 23:45	0.82	1/21/2024 12:45	-0.26	1/22/2024 1:45	1.81	1/22/2024 14:45	0.61
1/19/2024 9:00	-0.72	1/19/2024 22:00	0.03	1/20/2024 11:00	-1.42	1/21/2024 0:00	0.79	1/21/2024 13:00	-0.30	1/22/2024 2:00	1.79	1/22/2024 15:00	0.56
1/19/2024 9:15	-0.83	1/19/2024 22:15	0.18	1/20/2024 11:15	-1.48	1/21/2024 0:15	0.73	1/21/2024 13:15	-0.25	1/22/2024 2:15	1.74	1/22/2024 15:15	0.59
1/19/2024 9:30	-0.82	1/19/2024 22:30	0.07	1/20/2024 11:30	-1.47	1/21/2024 0:30	0.72	1/21/2024 13:30	-0.18	1/22/2024 2:30	1.84	1/22/2024 15:30	0.67
1/19/2024 9:45	-0.95	1/19/2024 22:45	0.04	1/20/2024 11:45	-1.49	1/21/2024 0:45	0.68	1/21/2024 13:45	-0.22	1/22/2024 2:45	1.90	1/22/2024 15:45	0.71
1/19/2024 10:00	-1.04	1/19/2024 23:00	0.03	1/20/2024 12:00	-1.45	1/21/2024 1:00	0.69	1/21/2024 14:00	-0.15	1/22/2024 3:00	1.94	1/22/2024 16:00	0.84
1/19/2024 10:15	-1.07	1/19/2024 23:15	0.10	1/20/2024 12:15	-1.43	1/21/2024 1:15	0.75	1/21/2024 14:15	-0.16	1/22/2024 3:15	2.01	1/22/2024 16:15	0.88
1/19/2024 10:30	-1.09	1/19/2024 23:30	0.08	1/20/2024 12:30	-1.41	1/21/2024 1:30	0.58	1/21/2024 14:30	-0.11	1/22/2024 3:30	1.97	1/22/2024 16:30	0.97
1/19/2024 10:45	-1.10	1/19/2024 23:45	0.04	1/20/2024 12:45	-1.36	1/21/2024 1:45	0.66	1/21/2024 14:45	0.01	1/22/2024 3:45	2.02	1/22/2024 16:45	1.05
1/19/2024 11:00	-1.12	1/20/2024 0:00	0.12	1/20/2024 13:00	-1.37	1/21/2024 2:00	0.75	1/21/2024 15:00	-0.02	1/22/2024 4:00	2.10	1/22/2024 17:00	1.10
1/19/2024 11:15	-1.16	1/20/2024 0:15	0.03	1/20/2024 13:15	-1.29	1/21/2024 2:15	0.77	1/21/2024 15:15	0.13	1/22/2024 4:15	2.10	1/22/2024 17:15	1.20
1/19/2024 11:30	-1.22	1/20/2024 0:30	0.10	1/20/2024 13:30	-1.26	1/21/2024 2:30	0.77	1/21/2024 15:30	0.09	1/22/2024 4:30	2.16	1/22/2024 17:30	1.29
1/19/2024 11:45	-1.21	1/20/2024 0:45	0.06	1/20/2024 13:45	-1.23	1/21/2024 2:45	0.69	1/21/2024 15:45	0.15	1/22/2024 4:45	2.14	1/22/2024 17:45	1.36
1/19/2024 12:00	-1.18	1/20/2024 1:00	0.06	1/20/2024 14:00	-1.23	1/21/2024 3:00	0.72	1/21/2024 16:00	0.29	1/22/2024 5:00	2.20	1/22/2024 18:00	1.45
1/19/2024 12:15	-1.25	1/20/2024 1:15	-0.03	1/20/2024 14:15	-1.13	1/21/2024 3:15	0.74	1/21/2024 16:15	0.38	1/22/2024 5:15	2.19	1/22/2024 18:15	1.54
1/19/2024 12:30	-1.25	1/20/2024 1:30	-0.08	1/20/2024 14:30	-1.08	1/21/2024 3:30	0.74	1/21/2024 16:30	0.41	1/22/2024 5:30	2.22	1/22/2024 18:30	1.65
1/19/2024 12:45	-1.21	1/20/2024 1:45	-0.11	1/20/2024 14:45	-1.01	1/21/2024 3:45	0.65	1/21/2024 16:45	0.48	1/22/2024 5:45	2.18	1/22/2024 18:45	1.74
1/19/2024 13:00	-1.10	1/20/2024 2:00	-0.08	1/20/2024 15:00	-0.94	1/21/2024 4:00	0.70	1/21/2024 17:00	0.64	1/22/2024 6:00	2.11	1/22/2024 19:00	1.83
1/19/2024 13:15	-1.10	1/20/2024 2:15	-0.26	1/20/2024 15:15	-0.85	1/21/2024 4:15	0.68	1/21/2024 17:15	0.69	1/22/2024 6:15	2.09	1/22/2024 19:15	1.90
1/19/2024 13:30	-1.04	1/20/2024 2:30	-0.25	1/20/2024 15:30	-0.77	1/21/2024 4:30	0.68	1/21/2024 17:30	0.77	1/22/2024 6:30	2.09	1/22/2024 19:30	1.95
1/19/2024 13:45	-1.04	1/20/2024 2:45	-0.32	1/20/2024 15:45	-0.70	1/21/2024 4:45	0.68	1/21/2024 17:45	0.88	1/22/2024 6:45	2.01	1/22/2024 19:45	2.00
1/19/2024 14:00	-1.00	1/20/2024 3:00	-0.28	1/20/2024 16:00	-0.63	1/21/2024 5:00	0.66	1/21/2024 18:00	1.00	1/22/2024 7:00	1.99	1/22/2024 20:00	2.01

Date & Time	Water Level (ft)	Date & Time	Water Level (ft)	Date & Time	Water Level (ft)	Date & Time	Water Level (ft)	Date & Time	Water Level (ft)	Date & Time	Water Level (ft)	Date & Time	Water Level (ft)
1/22/2024 20:15	2.03	1/23/2024 9:15	0.70	1/23/2024 22:15	1.49	1/24/2024 11:15	0.79	1/25/2024 0:15	2.28	1/25/2024 13:15	1.05	1/26/2024 2:15	1.82
1/22/2024 20:30	2.07	1/23/2024 9:30	0.61	1/23/2024 22:30	1.50	1/24/2024 11:30	0.81	1/25/2024 0:30	2.24	1/25/2024 13:30	1.04	1/26/2024 2:30	1.81
1/22/2024 20:45	2.11	1/23/2024 9:45	0.56	1/23/2024 22:45	1.53	1/24/2024 11:45	0.71	1/25/2024 0:45	2.28	1/25/2024 13:45	1.00	1/26/2024 2:45	1.79
1/22/2024 21:00	2.12	1/23/2024 10:00	0.49	1/23/2024 23:00	1.55	1/24/2024 12:00	0.67	1/25/2024 1:00	2.27	1/25/2024 14:00	0.96	1/26/2024 3:00	1.76
1/22/2024 21:15	2.10	1/23/2024 10:15	0.43	1/23/2024 23:15	1.56	1/24/2024 12:15	0.67	1/25/2024 1:15	2.22	1/25/2024 14:15	0.92	1/26/2024 3:15	1.74
1/22/2024 21:30	2.08	1/23/2024 10:30	0.36	1/23/2024 23:30	1.56	1/24/2024 12:30	0.58	1/25/2024 1:30	2.24	1/25/2024 14:30	0.86	1/26/2024 3:30	1.71
1/22/2024 21:45	2.07	1/23/2024 10:45	0.31	1/23/2024 23:45	1.56	1/24/2024 12:45	0.53	1/25/2024 1:45	2.25	1/25/2024 14:45	0.82	1/26/2024 3:45	1.71
1/22/2024 22:00	2.02	1/23/2024 11:00	0.24	1/24/2024 0:00	1.56	1/24/2024 13:00	0.48	1/25/2024 2:00	2.21	1/25/2024 15:00	0.79	1/26/2024 4:00	1.70
1/22/2024 22:15	1.98	1/23/2024 11:15	0.23	1/24/2024 0:15	1.56	1/24/2024 13:15	0.41	1/25/2024 2:15	2.19	1/25/2024 15:15	0.76	1/26/2024 4:15	1.66
1/22/2024 22:30	1.94	1/23/2024 11:30	0.17	1/24/2024 0:30	1.57	1/24/2024 13:30	0.43	1/25/2024 2:30	2.16	1/25/2024 15:30	0.74	1/26/2024 4:30	1.67
1/22/2024 22:45	1.89	1/23/2024 11:45	0.12	1/24/2024 0:45	1.56	1/24/2024 13:45	0.33	1/25/2024 2:45	2.14	1/25/2024 15:45	0.71	1/26/2024 4:45	1.67
1/22/2024 23:00	1.88	1/23/2024 12:00	0.08	1/24/2024 1:00	1.58	1/24/2024 14:00	0.29	1/25/2024 3:00	2.11	1/25/2024 16:00	0.69	1/26/2024 5:00	1.66
1/22/2024 23:15	1.87	1/23/2024 12:15	0.04	1/24/2024 1:15	1.59	1/24/2024 14:15	0.24	1/25/2024 3:15	2.13	1/25/2024 16:15	0.66	1/26/2024 5:15	1.64
1/22/2024 23:30	1.84	1/23/2024 12:30	-0.01	1/24/2024 1:30	1.59	1/24/2024 14:30	0.24	1/25/2024 3:30	2.12	1/25/2024 16:30	0.65	1/26/2024 5:30	1.65
1/22/2024 23:45	1.81	1/23/2024 12:45	-0.09	1/24/2024 1:45	1.60	1/24/2024 14:45	0.16	1/25/2024 3:45	2.05	1/25/2024 16:45	0.62	1/26/2024 5:45	1.65
1/23/2024 0:00	1.83	1/23/2024 13:00	-0.11	1/24/2024 2:00	1.60	1/24/2024 15:00	0.11	1/25/2024 4:00	2.09	1/25/2024 17:00	0.65	1/26/2024 6:00	1.65
1/23/2024 0:15	1.79	1/23/2024 13:15	-0.19	1/24/2024 2:15	1.60	1/24/2024 15:15	0.12	1/25/2024 4:15	2.13	1/25/2024 17:15	0.64	1/26/2024 6:15	1.65
1/23/2024 0:30	1.82	1/23/2024 13:30	-0.21	1/24/2024 2:30	1.60	1/24/2024 15:30	0.17	1/25/2024 4:30	1.87	1/25/2024 17:30	0.63	1/26/2024 6:30	1.63
1/23/2024 0:45	1.78	1/23/2024 13:45	-0.24	1/24/2024 2:45	1.58	1/24/2024 15:45	0.17	1/25/2024 4:45	2.11	1/25/2024 17:45	0.64	1/26/2024 6:45	1.64
1/23/2024 1:00	1.74	1/23/2024 14:00	-0.27	1/24/2024 3:00	1.55	1/24/2024 16:00	0.09	1/25/2024 5:00	2.10	1/25/2024 18:00	0.65	1/26/2024 7:00	1.64
1/23/2024 1:15	1.72	1/23/2024 14:15	-0.30	1/24/2024 3:15	1.54	1/24/2024 16:15	0.16	1/25/2024 5:15	1.80	1/25/2024 18:15	0.70	1/26/2024 7:15	1.65
1/23/2024 1:30	1.69	1/23/2024 14:30	-0.29	1/24/2024 3:30	1.54	1/24/2024 16:30	0.14	1/25/2024 5:30	1.98	1/25/2024 18:30	0.73	1/26/2024 7:30	1.65
1/23/2024 1:45	1.64	1/23/2024 14:45	-0.29	1/24/2024 3:45	1.50	1/24/2024 16:45	0.18	1/25/2024 5:45	1.97	1/25/2024 18:45	0.75	1/26/2024 7:45	1.66
1/23/2024 2:00	1.60	1/23/2024 15:00	-0.28	1/24/2024 4:00	1.56	1/24/2024 17:00	0.21	1/25/2024 6:00	1.86	1/25/2024 19:00	0.79	1/26/2024 8:00	1.66
1/23/2024 2:15	1.59	1/23/2024 15:15	-0.28	1/24/2024 4:15	1.45	1/24/2024 17:15	0.16	1/25/2024 6:15	1.85	1/25/2024 19:15	0.85	1/26/2024 8:15	1.68
1/23/2024 2:30	1.58	1/23/2024 15:30	-0.20	1/24/2024 4:30	1.50	1/24/2024 17:30	0.32	1/25/2024 6:30	1.79	1/25/2024 19:30	0.92	1/26/2024 8:30	1.66
1/23/2024 2:45	1.54	1/23/2024 15:45	-0.16	1/24/2024 4:45	1.48	1/24/2024 17:45	0.38	1/25/2024 6:45	1.74	1/25/2024 19:45	1.02	1/26/2024 8:45	1.65
1/23/2024 3:00	1.52	1/23/2024 16:00	-0.09	1/24/2024 5:00	1.49	1/24/2024 18:00	0.50	1/25/2024 7:00	1.79	1/25/2024 20:00	1.07	1/26/2024 9:00	1.62
1/23/2024 3:15	1.51	1/23/2024 16:15	0.00	1/24/2024 5:15	1.45	1/24/2024 18:15	0.56	1/25/2024 7:15	1.86	1/25/2024 20:15	1.14	1/26/2024 9:15	1.62
1/23/2024 3:30	1.45	1/23/2024 16:30	0.07	1/24/2024 5:30	1.48	1/24/2024 18:30	0.71	1/25/2024 7:30	1.90	1/25/2024 20:30	1.19	1/26/2024 9:30	1.59
1/23/2024 3:45	1.46	1/23/2024 16:45	0.16	1/24/2024 5:45	1.46	1/24/2024 18:45	0.77	1/25/2024 7:45	1.93	1/25/2024 20:45	1.26	1/26/2024 9:45	1.57
1/23/2024 4:00	1.41	1/23/2024 17:00	0.31	1/24/2024 6:00	1.40	1/24/2024 19:00	0.86	1/25/2024 8:00	1.90	1/25/2024 21:00	1.30	1/26/2024 10:00	1.53
1/23/2024 4:15	1.42	1/23/2024 17:15	0.37	1/24/2024 6:15	1.32	1/24/2024 19:15	0.99	1/25/2024 8:15	1.91	1/25/2024 21:15	1.37	1/26/2024 10:15	1.51
1/23/2024 4:30	1.39	1/23/2024 17:30	0.49	1/24/2024 6:30	1.37	1/24/2024 19:30	1.05	1/25/2024 8:30	1.88	1/25/2024 21:30	1.47	1/26/2024 10:30	1.47
1/23/2024 4:45	1.34	1/23/2024 17:45	0.56	1/24/2024 6:45	1.33	1/24/2024 19:45	1.15	1/25/2024 8:45	1.91	1/25/2024 21:45	1.54	1/26/2024 10:45	1.43
1/23/2024 5:00	1.29	1/23/2024 18:00	0.69	1/24/2024 7:00	1.27	1/24/2024 20:00	1.23	1/25/2024 9:00	1.89	1/25/2024 22:00	1.61	1/26/2024 11:00	1.42
1/23/2024 5:15	1.27	1/23/2024 18:15	0.76	1/24/2024 7:15	1.32	1/24/2024 20:15	1.32	1/25/2024 9:15	1.90	1/25/2024 22:15	1.69	1/26/2024 11:15	1.39
1/23/2024 5:30	1.27	1/23/2024 18:30	0.87	1/24/2024 7:30	1.32	1/24/2024 20:30	1.41	1/25/2024 9:30	1.86	1/25/2024 22:30	1.70	1/26/2024 11:30	1.35
1/23/2024 5:45	1.22	1/23/2024 18:45	0.94	1/24/2024 7:45	1.33	1/24/2024 20:45	1.52	1/25/2024 9:45	1.80	1/25/2024 22:45	1.76	1/26/2024 11:45	1.28
1/23/2024 6:00	1.20	1/23/2024 19:00	1.02	1/24/2024 8:00	1.39	1/24/2024 21:00	1.56	1/25/2024 10:00	1.77	1/25/2024 23:00	1.79	1/26/2024 12:00	1.29
1/23/2024 6:15	1.20	1/23/2024 19:15	1.08	1/24/2024 8:15	1.42	1/24/2024 21:15	1.66	1/25/2024 10:15	1.71	1/25/2024 23:15	1.82	1/26/2024 12:15	2.66
1/23/2024 6:30	1.17	1/23/2024 19:30	1.15	1/24/2024 8:30	1.36	1/24/2024 21:30	1.74	1/25/2024 10:30	1.70	1/25/2024 23:30	1.81	1/26/2024 12:30	1.81
1/23/2024 6:45	1.09	1/23/2024 19:45	1.26	1/24/2024 8:45	1.31	1/24/2024 21:45	1.76	1/25/2024 10:45	1.64	1/25/2024 23:45	1.83	1/26/2024 12:45	1.59
1/23/2024 7:00	1.05	1/23/2024 20:00	1.27	1/24/2024 9:00	1.25	1/24/2024 22:00	1.76	1/25/2024 11:00	1.59	1/26/2024 0:00	1.88	1/26/2024 13:00	1.40
1/23/2024 7:15	1.02	1/23/2024 20:15	1.33	1/24/2024 9:15	1.23	1/24/2024 22:15	1.87	1/25/2024 11:15	1.52	1/26/2024 0:15	1.89	1/26/2024 13:15	1.35
1/23/2024 7:30	1.00	1/23/2024 20:30	1.36	1/24/2024 9:30	1.17	1/24/2024 22:30	1.88	1/25/2024 11:30	1.48	1/26/2024 0:30	1.89	1/26/2024 13:30	1.28
1/23/2024 7:45	0.90	1/23/2024 20:45	1.39	1/24/2024 9:45	1.16	1/24/2024 22:45	2.00	1/25/2024 11:45	1.42	1/26/2024 0:45	1.91	1/26/2024 13:45	1.19
1/23/2024 8:00	0.89	1/23/2024 21:00	1.41	1/24/2024 10:00	1.10	1/24/2024 23:00	2.03	1/25/2024 12:00	1.35	1/26/2024 1:00	1.89	1/26/2024 14:00	1.16
1/23/2024 8:15	0.84	1/23/2024 21:15	1.44	1/24/2024 10:15	1.06	1/24/2024 23:15	2.09	1/25/2024 12:15	1.31	1/26/2024 1:15	1.92	1/26/2024 14:15	1.09
1/23/2024 8:30	0.78	1/23/2024 21:30	1.43	1/24/2024 10:30	0.96	1/24/2024 23:30	2.13	1/25/2024 12:30	1.23	1/26/2024 1:30	1.92	1/26/2024 14:30	1.06
1/23/2024 8:45	0.77	1/23/2024 21:45	1.46	1/24/2024 10:45	0.89	1/24/2024 23:45	2.21	1/25/2024 12:45	1.17	1/26/2024 1:45	1.88	1/26/2024 14:45	0.97
1/23/2024 9:00	0.67	1/23/2024 22:00	1.45	1/24/2024 11:00	0.85	1/25/2024 0:00	2.25	1/25/2024 13:00	1.11	1/26/2024 2:00	1.86	1/26/2024 15:00	0.96

Date & Time	Water Level (ft)	Date & Time	Water Level (ft)	Date & Time	Water Level (ft)	Date & Time	Water Level (ft)	Date & Time	Water Level (ft)	Date & Time	Water Level (ft)	Date & Time	Water Level (ft)
1/26/2024 15:15	0.92	1/27/2024 4:15	2.61	1/27/2024 17:15	1.15	1/28/2024 6:15	0.79	1/28/2024 19:15	-0.29	1/29/2024 8:15	0.30	1/29/2024 21:15	-0.04
1/26/2024 15:30	0.87	1/27/2024 4:30	2.58	1/27/2024 17:30	1.12	1/28/2024 6:30	0.82	1/28/2024 19:30	-0.26	1/29/2024 8:30	0.30	1/29/2024 21:30	0.04
1/26/2024 15:45	0.86	1/27/2024 4:45	2.54	1/27/2024 17:45	1.14	1/28/2024 6:45	0.81	1/28/2024 19:45	-0.25	1/29/2024 8:45	0.32	1/29/2024 21:45	0.09
1/26/2024 16:00	0.83	1/27/2024 5:00	2.55	1/27/2024 18:00	1.14	1/28/2024 7:00	0.74	1/28/2024 20:00	-0.21	1/29/2024 9:00	0.32	1/29/2024 22:00	0.15
1/26/2024 16:15	0.89	1/27/2024 5:15	2.53	1/27/2024 18:15	1.11	1/28/2024 7:15	0.74	1/28/2024 20:15	-0.17	1/29/2024 9:15	0.32	1/29/2024 22:15	0.22
1/26/2024 16:30	0.82	1/27/2024 5:30	2.54	1/27/2024 18:30	1.11	1/28/2024 7:30	0.70	1/28/2024 20:30	-0.13	1/29/2024 9:30	0.31	1/29/2024 22:30	0.31
1/26/2024 16:45	0.82	1/27/2024 5:45	2.48	1/27/2024 18:45	1.08	1/28/2024 7:45	0.71	1/28/2024 20:45	-0.09	1/29/2024 9:45	0.31	1/29/2024 22:45	0.38
1/26/2024 17:00	0.85	1/27/2024 6:00	2.58	1/27/2024 19:00	0.98	1/28/2024 8:00	0.67	1/28/2024 21:00	-0.05	1/29/2024 10:00	0.30	1/29/2024 23:00	0.42
1/26/2024 17:15	0.87	1/27/2024 6:15	2.53	1/27/2024 19:15	1.01	1/28/2024 8:15	0.65	1/28/2024 21:15	0.01	1/29/2024 10:15	0.31	1/29/2024 23:15	0.42
1/26/2024 17:30	0.92	1/27/2024 6:30	2.45	1/27/2024 19:30	0.96	1/28/2024 8:30	0.63	1/28/2024 21:30	0.06	1/29/2024 10:30	0.30	1/29/2024 23:30	0.46
1/26/2024 17:45	0.96	1/27/2024 6:45	2.08	1/27/2024 19:45	0.98	1/28/2024 8:45	0.57	1/28/2024 21:45	0.10	1/29/2024 10:45	0.30	1/29/2024 23:45	0.51
1/26/2024 18:00	0.97	1/27/2024 7:00	2.36	1/27/2024 20:00	0.97	1/28/2024 9:00	0.62	1/28/2024 22:00	0.15	1/29/2024 11:00	0.28	1/30/2024 0:00	0.56
1/26/2024 18:15	1.06	1/27/2024 7:15	2.48	1/27/2024 20:15	0.96	1/28/2024 9:15	0.63	1/28/2024 22:15	0.19	1/29/2024 11:15	0.28	1/30/2024 0:15	0.59
1/26/2024 18:30	1.24	1/27/2024 7:30	2.41	1/27/2024 20:30	0.97	1/28/2024 9:30	0.61	1/28/2024 22:30	0.25	1/29/2024 11:30	0.27	1/30/2024 0:30	0.62
1/26/2024 18:45	1.31	1/27/2024 7:45	2.40	1/27/2024 20:45	0.99	1/28/2024 9:45	0.60	1/28/2024 22:45	0.30	1/29/2024 11:45	0.25	1/30/2024 0:45	0.64
1/26/2024 19:00	1.39	1/27/2024 8:00	2.34	1/27/2024 21:00	0.97	1/28/2024 10:00	0.55	1/28/2024 23:00	0.34	1/29/2024 12:00	0.22	1/30/2024 1:00	0.67
1/26/2024 19:15	1.44	1/27/2024 8:15	2.24	1/27/2024 21:15	0.99	1/28/2024 10:15	0.52	1/28/2024 23:15	0.39	1/29/2024 12:15	0.20	1/30/2024 1:15	0.66
1/26/2024 19:30	1.47	1/27/2024 8:30	2.26	1/27/2024 21:30	1.03	1/28/2024 10:30	0.53	1/28/2024 23:30	0.44	1/29/2024 12:30	0.18	1/30/2024 1:30	0.66
1/26/2024 19:45	1.55	1/27/2024 8:45	1.98	1/27/2024 21:45	1.04	1/28/2024 10:45	0.49	1/28/2024 23:45	0.49	1/29/2024 12:45	0.16	1/30/2024 1:45	0.68
1/26/2024 20:00	1.60	1/27/2024 9:00	2.17	1/27/2024 22:00	1.06	1/28/2024 11:00	0.53	1/29/2024 0:00	0.53	1/29/2024 13:00	0.13	1/30/2024 2:00	0.64
1/26/2024 20:15	1.68	1/27/2024 9:15	2.12	1/27/2024 22:15	1.09	1/28/2024 11:15	0.47	1/29/2024 0:15	0.57	1/29/2024 13:15	0.10	1/30/2024 2:15	0.63
1/26/2024 20:30	1.75	1/27/2024 9:30	2.06	1/27/2024 22:30	1.10	1/28/2024 11:30	0.43	1/29/2024 0:30	0.60	1/29/2024 13:30	0.05	1/30/2024 2:30	0.61
1/26/2024 20:45	1.81	1/27/2024 9:45	2.09	1/27/2024 22:45	1.14	1/28/2024 11:45	0.46	1/29/2024 0:45	0.63	1/29/2024 13:45	0.01	1/30/2024 2:45	0.59
1/26/2024 21:00	1.90	1/27/2024 10:00	2.05	1/27/2024 23:00	1.17	1/28/2024 12:00	0.43	1/29/2024 1:00	0.65	1/29/2024 14:00	-0.02	1/30/2024 3:00	0.58
1/26/2024 21:15	1.94	1/27/2024 10:15	2.02	1/27/2024 23:15	1.19	1/28/2024 12:15	0.41	1/29/2024 1:15	0.65	1/29/2024 14:15	-0.07	1/30/2024 3:15	0.54
1/26/2024 21:30	1.98	1/27/2024 10:30	1.94	1/27/2024 23:30	1.24	1/28/2024 12:30	0.36	1/29/2024 1:30	0.66	1/29/2024 14:30	-0.12	1/30/2024 3:30	0.53
1/26/2024 21:45	2.04	1/27/2024 10:45	1.76	1/27/2024 23:45	1.25	1/28/2024 12:45	0.33	1/29/2024 1:45	0.67	1/29/2024 14:45	-0.16	1/30/2024 3:45	0.49
1/26/2024 22:00	2.09	1/27/2024 11:00	1.83	1/28/2024 0:00	1.29	1/28/2024 13:00	0.28	1/29/2024 2:00	0.67	1/29/2024 15:00	-0.22	1/30/2024 4:00	0.46
1/26/2024 22:15	2.13	1/27/2024 11:15	1.81	1/28/2024 0:15	1.31	1/28/2024 13:15	0.27	1/29/2024 2:15	0.66	1/29/2024 15:15	-0.26	1/30/2024 4:15	0.43
1/26/2024 22:30	2.17	1/27/2024 11:30	1.84	1/28/2024 0:30	1.32	1/28/2024 13:30	0.23	1/29/2024 2:30	0.65	1/29/2024 15:30	-0.29	1/30/2024 4:30	0.40
1/26/2024 22:45	2.23	1/27/2024 11:45	1.84	1/28/2024 0:45	1.35	1/28/2024 13:45	0.19	1/29/2024 2:45	0.64	1/29/2024 15:45	-0.34	1/30/2024 4:45	0.36
1/26/2024 23:00	2.31	1/27/2024 12:00	1.77	1/28/2024 1:00	1.34	1/28/2024 14:00	0.14	1/29/2024 3:00	0.64	1/29/2024 16:00	-0.37	1/30/2024 5:00	0.35
1/26/2024 23:15	2.33	1/27/2024 12:15	1.75	1/28/2024 1:15	1.36	1/28/2024 14:15	0.12	1/29/2024 3:15	0.61	1/29/2024 16:15	-0.40	1/30/2024 5:15	0.33
1/26/2024 23:30	2.35	1/27/2024 12:30	1.64	1/28/2024 1:30	1.35	1/28/2024 14:30	0.07	1/29/2024 3:30	0.59	1/29/2024 16:30	-0.46	1/30/2024 5:30	0.30
1/26/2024 23:45	2.33	1/27/2024 12:45	1.66	1/28/2024 1:45	1.35	1/28/2024 14:45	0.07	1/29/2024 3:45	0.58	1/29/2024 16:45	-0.49	1/30/2024 5:45	0.28
1/27/2024 0:00	2.40	1/27/2024 13:00	1.70	1/28/2024 2:00	1.34	1/28/2024 15:00	0.03	1/29/2024 4:00	0.55	1/29/2024 17:00	-0.52	1/30/2024 6:00	0.25
1/27/2024 0:15	2.41	1/27/2024 13:15	1.59	1/28/2024 2:15	1.31	1/28/2024 15:15	0.00	1/29/2024 4:15	0.52	1/29/2024 17:15	-0.55	1/30/2024 6:15	0.22
1/27/2024 0:30	2.47	1/27/2024 13:30	1.70	1/28/2024 2:30	1.29	1/28/2024 15:30	-0.06	1/29/2024 4:30	0.50	1/29/2024 17:30	-0.56	1/30/2024 6:30	0.19
1/27/2024 0:45	2.44	1/27/2024 13:45	1.53	1/28/2024 2:45	1.28	1/28/2024 15:45	-0.07	1/29/2024 4:45	0.48	1/29/2024 17:45	-0.57	1/30/2024 6:45	0.16
1/27/2024 1:00	2.47	1/27/2024 14:00	1.54	1/28/2024 3:00	1.25	1/28/2024 16:00	-0.10	1/29/2024 5:00	0.46	1/29/2024 18:00	-0.58	1/30/2024 7:00	0.13
1/27/2024 1:15	2.52	1/27/2024 14:15	1.59	1/28/2024 3:15	1.25	1/28/2024 16:15	-0.14	1/29/2024 5:15	0.43	1/29/2024 18:15	-0.55	1/30/2024 7:15	0.11
1/27/2024 1:30	2.52	1/27/2024 14:30	1.50	1/28/2024 3:30	1.21	1/28/2024 16:30	-0.17	1/29/2024 5:30	0.41	1/29/2024 18:30	-0.58	1/30/2024 7:30	0.08
1/27/2024 1:45	2.56	1/27/2024 14:45	1.48	1/28/2024 3:45	1.20	1/28/2024 16:45	-0.19	1/29/2024 5:45	0.39	1/29/2024 18:45	-0.56	1/30/2024 7:45	0.06
1/27/2024 2:00	2.53	1/27/2024 15:00	1.35	1/28/2024 4:00	1.13	1/28/2024 17:00	-0.23	1/29/2024 6:00	0.38	1/29/2024 19:00	-0.55	1/30/2024 8:00	0.03
1/27/2024 2:15	2.60	1/27/2024 15:15	1.50	1/28/2024 4:15	1.13	1/28/2024 17:15	-0.24	1/29/2024 6:15	0.37	1/29/2024 19:15	-0.51	1/30/2024 8:15	0.02
1/27/2024 2:30	2.60	1/27/2024 15:30	1.39	1/28/2024 4:30	1.11	1/28/2024 17:30	-0.27	1/29/2024 6:30	0.35	1/29/2024 19:30	-0.47	1/30/2024 8:30	0.01
1/27/2024 2:45	2.60	1/27/2024 15:45	1.34	1/28/2024 4:45	1.09	1/28/2024 17:45	-0.31	1/29/2024 6:45	0.34	1/29/2024 19:45	-0.42	1/30/2024 8:45	-0.01
1/27/2024 3:00	2.60	1/27/2024 16:00	1.34	1/28/2024 5:00	1.00	1/28/2024 18:00	-0.32	1/29/2024 7:00	0.34	1/29/2024 20:00	-0.37	1/30/2024 9:00	-0.02
1/27/2024 3:15	2.58	1/27/2024 16:15	1.29	1/28/2024 5:15	1.02	1/28/2024 18:15	-0.32	1/29/2024 7:15	0.32	1/29/2024 20:15	-0.32	1/30/2024 9:15	-0.02
1/27/2024 3:30	2.62	1/27/2024 16:30	1.26	1/28/2024 5:30	0.99	1/28/2024 18:30	-0.33	1/29/2024 7:30	0.31	1/29/2024 20:30	-0.25	1/30/2024 9:30	-0.06
1/27/2024 3:45	2.69	1/27/2024 16:45	1.22	1/28/2024 5:45	0.95	1/28/2024 18:45	-0.32	1/29/2024 7:45	0.30	1/29/2024 20:45	-0.21	1/30/2024 9:45	-0.06
1/27/2024 4:00	2.60	1/27/2024 17:00	1.22	1/28/2024 6:00	0.89	1/28/2024 19:00	-0.30	1/29/2024 8:00	0.29	1/29/2024 21:00	-0.11	1/30/2024 10:00	-0.07

Date & Time	Water Level (ft)	Date & Time	Water Level (ft)	Date & Time	Water Level (ft)	Date & Time	Water Level (ft)	Date & Time	Water Level (ft)	Date & Time	Water Level (ft)
1/30/2024 10:15	-0.07	1/30/2024 23:15	0.08	1/31/2024 12:15	-0.41	2/1/2024 1:15	-0.02	2/1/2024 14:15	0.32	2/2/2024 3:15	0.61
1/30/2024 10:30	-0.08	1/30/2024 23:30	0.15	1/31/2024 12:30	-0.40	2/1/2024 1:30	-0.04	2/1/2024 14:30	0.37	2/2/2024 3:30	0.54
1/30/2024 10:45	-0.08	1/30/2024 23:45	0.23	1/31/2024 12:45	-0.37	2/1/2024 1:45	-0.04	2/1/2024 14:45	0.37	2/2/2024 3:45	0.52
1/30/2024 11:00	-0.05	1/31/2024 0:00	0.26	1/31/2024 13:00	-0.33	2/1/2024 2:00	-0.01	2/1/2024 15:00	0.41	2/2/2024 4:00	0.49
1/30/2024 11:15	-0.03	1/31/2024 0:15	0.29	1/31/2024 13:15	-0.30	2/1/2024 2:15	0.00	2/1/2024 15:15	0.40	2/2/2024 4:15	0.44
1/30/2024 11:30	-0.05	1/31/2024 0:30	0.32	1/31/2024 13:30	-0.27	2/1/2024 2:30	-0.04	2/1/2024 15:30	0.41	2/2/2024 4:30	0.40
1/30/2024 11:45	-0.04	1/31/2024 0:45	0.33	1/31/2024 13:45	-0.27	2/1/2024 2:45	-0.06	2/1/2024 15:45	0.44	2/2/2024 4:45	0.34
1/30/2024 12:00	-0.06	1/31/2024 1:00	0.34	1/31/2024 14:00	-0.25	2/1/2024 3:00	-0.07	2/1/2024 16:00	0.43	2/2/2024 5:00	0.30
1/30/2024 12:15	-0.08	1/31/2024 1:15	0.35	1/31/2024 14:15	-0.23	2/1/2024 3:15	-0.09	2/1/2024 16:15	0.46	2/2/2024 5:15	0.26
1/30/2024 12:30	-0.02	1/31/2024 1:30	0.34	1/31/2024 14:30	-0.24	2/1/2024 3:30	-0.11	2/1/2024 16:30	0.46	2/2/2024 5:30	0.21
1/30/2024 12:45	-0.08	1/31/2024 1:45	0.34	1/31/2024 14:45	-0.26	2/1/2024 3:45	-0.15	2/1/2024 16:45	0.49	2/2/2024 5:45	0.15
1/30/2024 13:00	-0.09	1/31/2024 2:00	0.33	1/31/2024 15:00	-0.26	2/1/2024 4:00	-0.17	2/1/2024 17:00	0.50	2/2/2024 6:00	0.07
1/30/2024 13:15	-0.12	1/31/2024 2:15	0.31	1/31/2024 15:15	-0.28	2/1/2024 4:15	-0.20	2/1/2024 17:15	0.53	2/2/2024 6:15	0.04
1/30/2024 13:30	-0.13	1/31/2024 2:30	0.28	1/31/2024 15:30	-0.28	2/1/2024 4:30	-0.24	2/1/2024 17:30	0.55	2/2/2024 6:30	0.00
1/30/2024 13:45	-0.11	1/31/2024 2:45	0.24	1/31/2024 15:45	-0.30	2/1/2024 4:45	-0.29	2/1/2024 17:45	0.55	2/2/2024 6:45	-0.04
1/30/2024 14:00	-0.12	1/31/2024 3:00	0.20	1/31/2024 16:00	-0.33	2/1/2024 5:00	-0.34	2/1/2024 18:00	0.52		
1/30/2024 14:15	-0.14	1/31/2024 3:15	0.15	1/31/2024 16:15	-0.35	2/1/2024 5:15	-0.38	2/1/2024 18:15	0.52		
1/30/2024 14:30	-0.17	1/31/2024 3:30	0.11	1/31/2024 16:30	-0.38	2/1/2024 5:30	-0.43	2/1/2024 18:30	0.51		
1/30/2024 14:45	-0.23	1/31/2024 3:45	0.05	1/31/2024 16:45	-0.42	2/1/2024 5:45	-0.46	2/1/2024 18:45	0.49		
1/30/2024 15:00	-0.28	1/31/2024 4:00	-0.01	1/31/2024 17:00	-0.45	2/1/2024 6:00	-0.49	2/1/2024 19:00	0.48		
1/30/2024 15:15	-0.32	1/31/2024 4:15	-0.05	1/31/2024 17:15	-0.50	2/1/2024 6:15	-0.54	2/1/2024 19:15	0.46		
1/30/2024 15:30	-0.35	1/31/2024 4:30	-0.10	1/31/2024 17:30	-0.51	2/1/2024 6:30	-0.56	2/1/2024 19:30	0.45		
1/30/2024 15:45	-0.36	1/31/2024 4:45	-0.14	1/31/2024 17:45	-0.52	2/1/2024 6:45	-0.61	2/1/2024 19:45	0.46		
1/30/2024 16:00	-0.39	1/31/2024 5:00	-0.20	1/31/2024 18:00	-0.54	2/1/2024 7:00	-0.63	2/1/2024 20:00	0.47		
1/30/2024 16:15	-0.44	1/31/2024 5:15	-0.24	1/31/2024 18:15	-0.55	2/1/2024 7:15	-0.67	2/1/2024 20:15	0.49		
1/30/2024 16:30	-0.47	1/31/2024 5:30	-0.29	1/31/2024 18:30	-0.60	2/1/2024 7:30	-0.69	2/1/2024 20:30	0.51		
1/30/2024 16:45	-0.49	1/31/2024 5:45	-0.33	1/31/2024 18:45	-0.64	2/1/2024 7:45	-0.72	2/1/2024 20:45	0.47		
1/30/2024 17:00	-0.47	1/31/2024 6:00	-0.37	1/31/2024 19:00	-0.62	2/1/2024 8:00	-0.75	2/1/2024 21:00	0.45		
1/30/2024 17:15	-0.48	1/31/2024 6:15	-0.41	1/31/2024 19:15	-0.60	2/1/2024 8:15	-0.77	2/1/2024 21:15	0.46		
1/30/2024 17:30	-0.52	1/31/2024 6:30	-0.45	1/31/2024 19:30	-0.58	2/1/2024 8:30	-0.77	2/1/2024 21:30	0.52		
1/30/2024 17:45	-0.56	1/31/2024 6:45	-0.49	1/31/2024 19:45	-0.56	2/1/2024 8:45	-0.75	2/1/2024 21:45	0.54		
1/30/2024 18:00	-0.59	1/31/2024 7:00	-0.50	1/31/2024 20:00	-0.57	2/1/2024 9:00	-0.73	2/1/2024 22:00	0.55		
1/30/2024 18:15	-0.60	1/31/2024 7:15	-0.55	1/31/2024 20:15	-0.55	2/1/2024 9:15	-0.73	2/1/2024 22:15	0.56		
1/30/2024 18:30	-0.59	1/31/2024 7:30	-0.55	1/31/2024 20:30	-0.54	2/1/2024 9:30	-0.70	2/1/2024 22:30	0.58		
1/30/2024 18:45	-0.59	1/31/2024 7:45	-0.58	1/31/2024 20:45	-0.50	2/1/2024 9:45	-0.67	2/1/2024 22:45	0.64		
1/30/2024 19:00	-0.57	1/31/2024 8:00	-0.59	1/31/2024 21:00	-0.46	2/1/2024 10:00	-0.63	2/1/2024 23:00	0.64		
1/30/2024 19:15	-0.56	1/31/2024 8:15	-0.60	1/31/2024 21:15	-0.45	2/1/2024 10:15	-0.60	2/1/2024 23:15	0.67		
1/30/2024 19:30	-0.54	1/31/2024 8:30	-0.61	1/31/2024 21:30	-0.42	2/1/2024 10:30	-0.55	2/1/2024 23:30	0.72		
1/30/2024 19:45	-0.52	1/31/2024 8:45	-0.66	1/31/2024 21:45	-0.39	2/1/2024 10:45	-0.50	2/1/2024 23:45	0.73		
1/30/2024 20:00	-0.50	1/31/2024 9:00	-0.64	1/31/2024 22:00	-0.35	2/1/2024 11:00	-0.41	2/2/2024 0:00	0.73		
1/30/2024 20:15	-0.47	1/31/2024 9:15	-0.65	1/31/2024 22:15	-0.34	2/1/2024 11:15	-0.36	2/2/2024 0:15	0.75		
1/30/2024 20:30	-0.44	1/31/2024 9:30	-0.63	1/31/2024 22:30	-0.30	2/1/2024 11:30	-0.29	2/2/2024 0:30	0.77		
1/30/2024 20:45	-0.42	1/31/2024 9:45	-0.60	1/31/2024 22:45	-0.25	2/1/2024 11:45	-0.25	2/2/2024 0:45	0.77		
1/30/2024 21:00	-0.38	1/31/2024 10:00	-0.62	1/31/2024 23:00	-0.23	2/1/2024 12:00	-0.17	2/2/2024 1:00	0.78		
1/30/2024 21:15	-0.34	1/31/2024 10:15	-0.63	1/31/2024 23:15	-0.23	2/1/2024 12:15	-0.09	2/2/2024 1:15	0.78		
1/30/2024 21:30	-0.28	1/31/2024 10:30	-0.61	1/31/2024 23:30	-0.21	2/1/2024 12:30	-0.05	2/2/2024 1:30	0.77		
1/30/2024 21:45	-0.23	1/31/2024 10:45	-0.56	1/31/2024 23:45	-0.16	2/1/2024 12:45	0.00	2/2/2024 1:45	0.75		
1/30/2024 22:00	-0.22	1/31/2024 11:00	-0.52	2/1/2024 0:00	-0.10	2/1/2024 13:00	0.06	2/2/2024 2:00	0.73		
1/30/2024 22:15	-0.16	1/31/2024 11:15	-0.49	2/1/2024 0:15	-0.08	2/1/2024 13:15	0.10	2/2/2024 2:15	0.70		
1/30/2024 22:30	-0.07	1/31/2024 11:30	-0.46	2/1/2024 0:30	-0.07	2/1/2024 13:30	0.16	2/2/2024 2:30	0.69		
1/30/2024 22:45	0.01	1/31/2024 11:45	-0.45	2/1/2024 0:45	-0.06	2/1/2024 13:45	0.20	2/2/2024 2:45	0.65		
1/30/2024 23:00	0.05	1/31/2024 12:00	-0.41	2/1/2024 1:00	-0.05	2/1/2024 14:00	0.26	2/2/2024 3:00	0.63		

# **Attachment 4**

**Slope Stability - Excavation**



Client IPC and MIMC Job Number 11215702 Sheet \_\_\_\_\_  
Project San Jacinto River Waste Pits Site Sheets By S.Chilka Date 07-17-2024  
Subject BMP Design - Geotechnical Parameters Checked By \_\_\_\_\_ Date \_\_\_\_\_

APPENDIX I - BMP STRUCTURAL DESIGN REPORT  
**ATTACHMENT 4**  
**SLOPE STABILITY - EXCAVATION**

Method: Spencer  
 Slip Surface Option: Block  
 Factor of Safety: 2.29

SJSB058-G  
 &  
 SJSB057-G

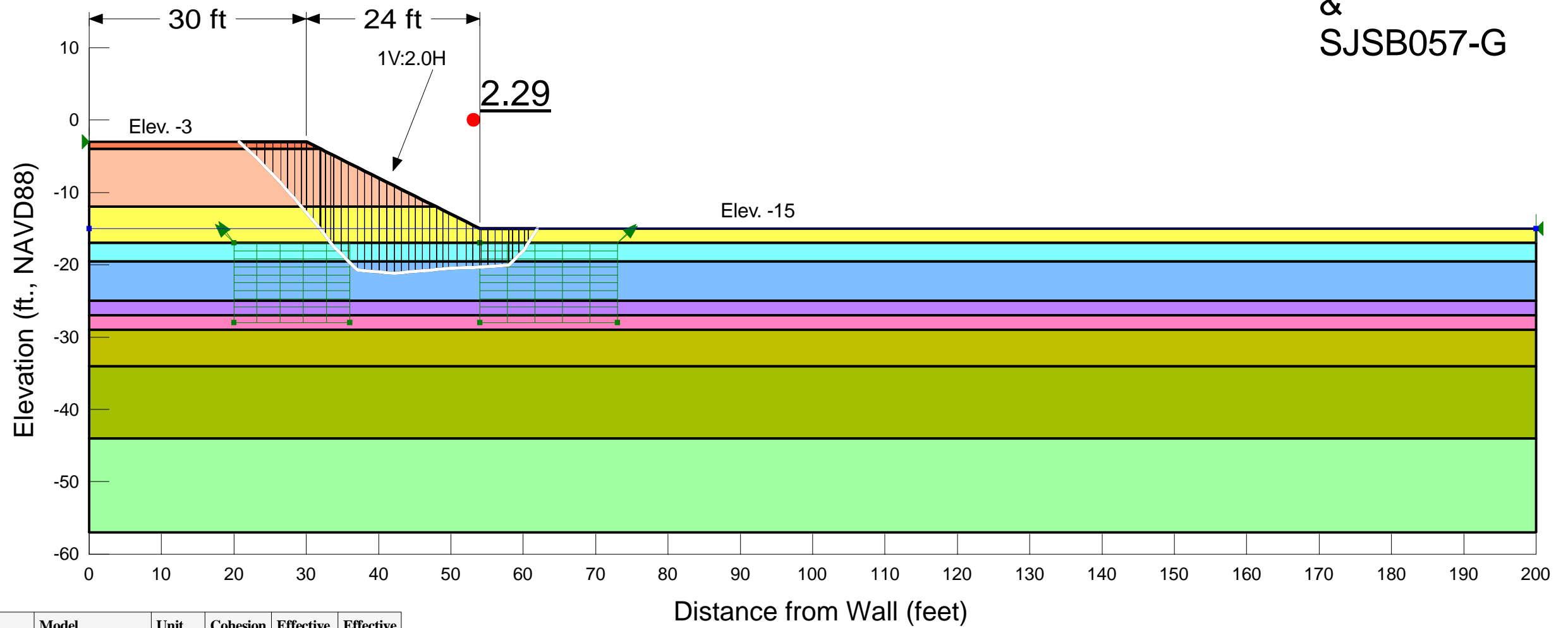

Color	Name	Model	Unit Weight (pcf)	Cohesion (psf)	Effective Cohesion (psf)	Effective Friction Angle (°)
Blue	SJSB057-G 06 - SC (-19.5 to -25)	Mohr-Coulomb	122		0	30
Purple	SJSB057-G 07 - SC (-25 to -27)	Mohr-Coulomb	122		0	30
Pink	SJSB057-G 08 - SC (-27 to -29)	Mohr-Coulomb	122		0	30
Olive	SJSB057-G 09 - CH (-29 to -34)	Undrained (Phi=0)	130	2,250		
Green	SJSB057-G 10 - CLS (-34 to -44)	Undrained (Phi=0)	135	2,250		
Light Green	SJSB057-G 11 - CH (-44 to -57)	Undrained (Phi=0)	125	2,300		
Orange	SJSB058-G 02 - CLS (-2 to -4)	Undrained (Phi=0)	110	200		
Light Orange	SJSB058-G 03 - CL (-4 to -12)	Undrained (Phi=0)	115	950		
Yellow	SJSB058-G 04 - SM (-12 to -17)	Mohr-Coulomb	120		0	30
Cyan	SJSB058-G 05 - SM (-17 to -19.5)	Mohr-Coulomb	122		0	30

Notes:  
 - Piezometric line maintained at bottom of excavation  
 - Soil properties taken from individual soil boring

Analysis Name: 1V:2.0H - Spencer Block

File Name: SJSB058-G (Excavation to -15).gsz

Date: 11/30/2020

Scale: 1:200

Method: Spencer  
 Slip Surface Option: Entry and Exit  
 Factor of Safety: 2.25

SJSB058-G  
 &  
 SJSB057-G

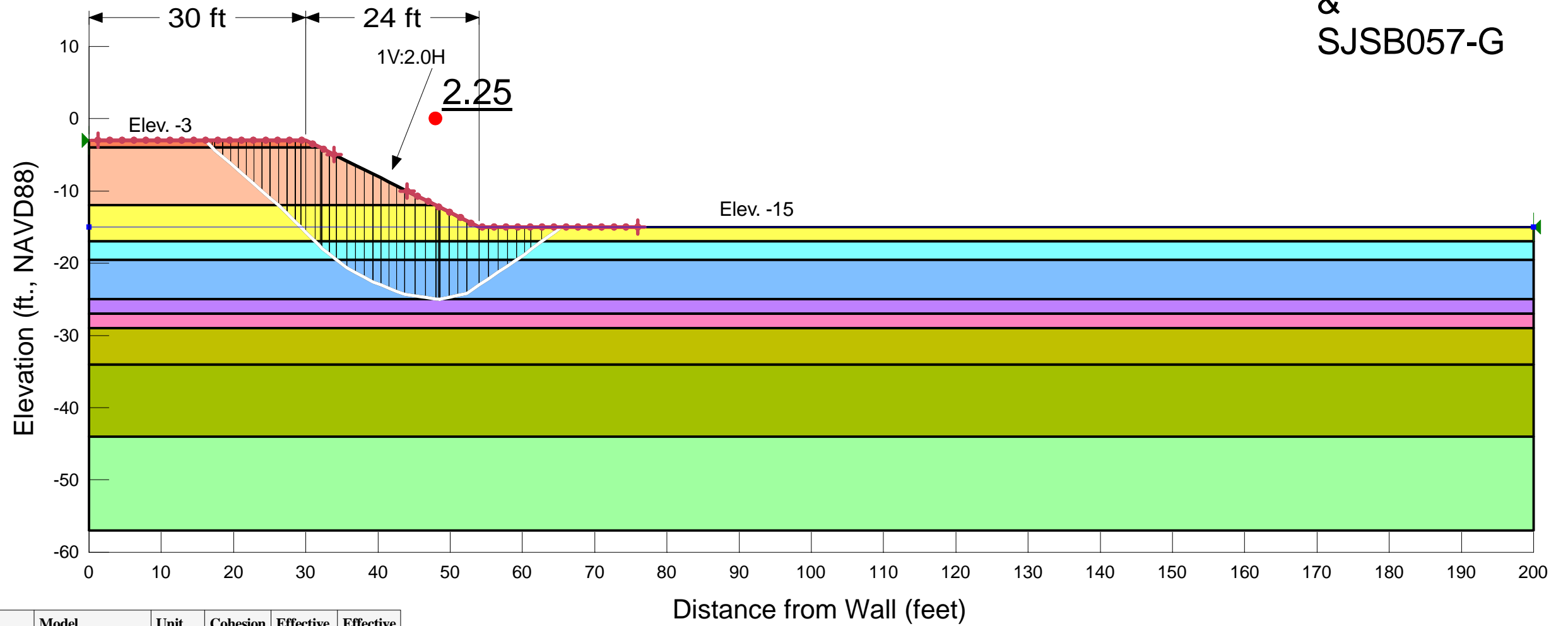

Color	Name	Model	Unit Weight (pcf)	Cohesion (psf)	Effective Cohesion (psf)	Effective Friction Angle (°)
Blue	SJSB057-G 06 - SC (-19.5 to -25)	Mohr-Coulomb	122		0	30
Purple	SJSB057-G 07 - SC (-25 to -27)	Mohr-Coulomb	122		0	30
Pink	SJSB057-G 08 - SC (-27 to -29)	Mohr-Coulomb	122		0	30
Olive	SJSB057-G 09 - CH (-29 to -34)	Undrained (Phi=0)	130	2,250		
Green	SJSB057-G 10 - CLS (-34 to -44)	Undrained (Phi=0)	135	2,250		
Light Green	SJSB057-G 11 - CH (-44 to -57)	Undrained (Phi=0)	125	2,300		
Orange	SJSB058-G 02 - CLS (-2 to -4)	Undrained (Phi=0)	110	200		
Light Orange	SJSB058-G 03 - CL (-4 to -12)	Undrained (Phi=0)	115	950		
Yellow	SJSB058-G 04 - SM (-12 to -17)	Mohr-Coulomb	120		0	30
Cyan	SJSB058-G 05 - SM (-17 to -19.5)	Mohr-Coulomb	122		0	30

Notes:  
 - Piezometric line maintained at bottom of excavation  
 - Soil properties taken from individual soil boring

Analysis Name: 1V:2.0H - Spencer EE

File Name: SJSB058-G (Excavation to -15).gsz

Date: 11/30/2020

Scale: 1:200

Method: Spencer  
 Slip Surface Option: Entry and Exit  
 Factor of Safety: 2.15

SJSB058-G  
 &  
 SJSB057-G

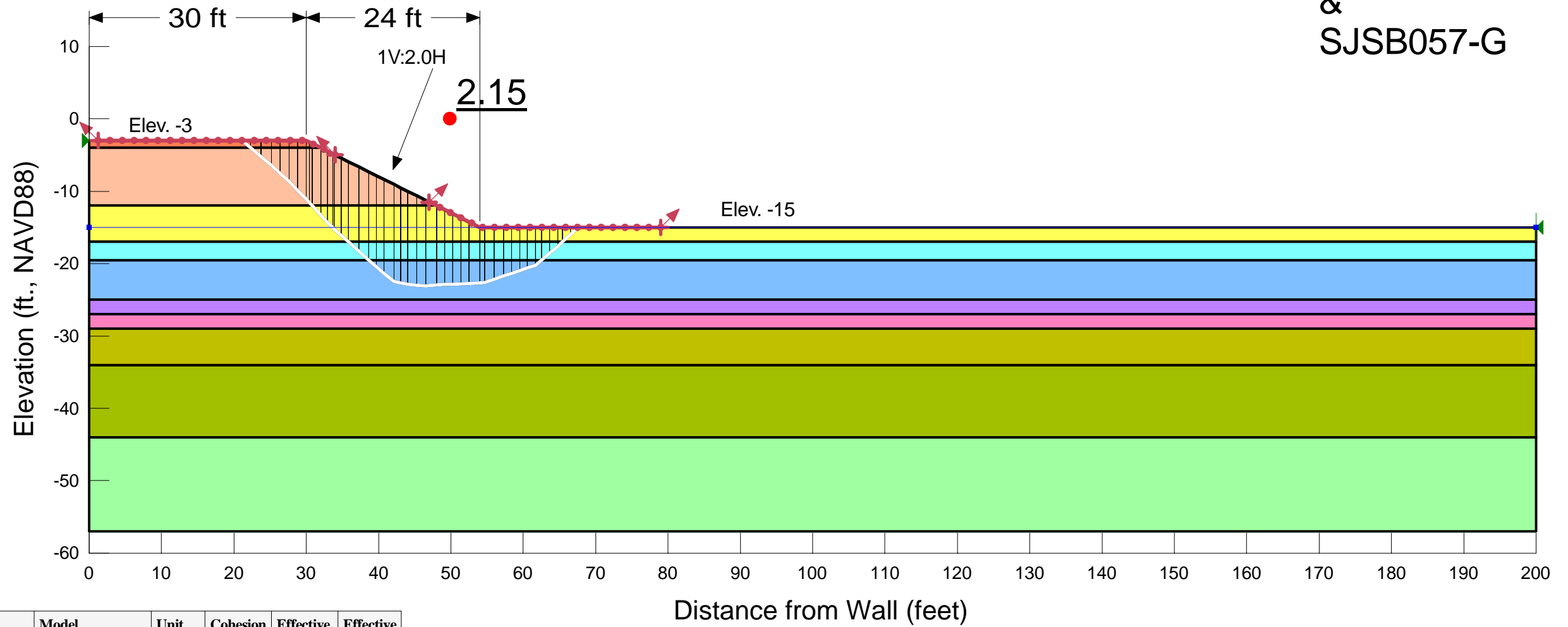

Color	Name	Model	Unit Weight (pcf)	Cohesion (psf)	Effective Cohesion (psf)	Effective Friction Angle (°)
Blue	SJSB057-G 06 - SC (-19.5 to -25)	Mohr-Coulomb	122		0	30
Purple	SJSB057-G 07 - SC (-25 to -27)	Mohr-Coulomb	122		0	30
Pink	SJSB057-G 08 - SC (-27 to -29)	Mohr-Coulomb	122		0	30
Olive	SJSB057-G 09 - CH (-29 to -34)	Undrained (Phi=0)	130	2,250		
Green	SJSB057-G 10 - CLS (-34 to -44)	Undrained (Phi=0)	135	2,250		
Light Green	SJSB057-G 11 - CH (-44 to -57)	Undrained (Phi=0)	125	2,300		
Orange	SJSB058-G 02 - CLS (-2 to -4)	Undrained (Phi=0)	110	200		
Light Orange	SJSB058-G 03 - CL (-4 to -12)	Undrained (Phi=0)	115	950		
Yellow	SJSB058-G 04 - SM (-12 to -17)	Mohr-Coulomb	120		0	30
Cyan	SJSB058-G 05 - SM (-17 to -19.5)	Mohr-Coulomb	122		0	30

Notes:  
 - Piezometric line maintained at bottom of excavation  
 - Soil properties taken from individual soil boring

Analysis Name: 1V:2.0H - Spencer EE (45-deg)

File Name: SJSB058-G (Excavation to -15).gsz

Date: 11/30/2020

Scale: 1:200



Method: Spencer  
 Slip Surface Option: Block  
 Factor of Safety: 1.77

SJSB058-G  
 &  
 SJSB057-G

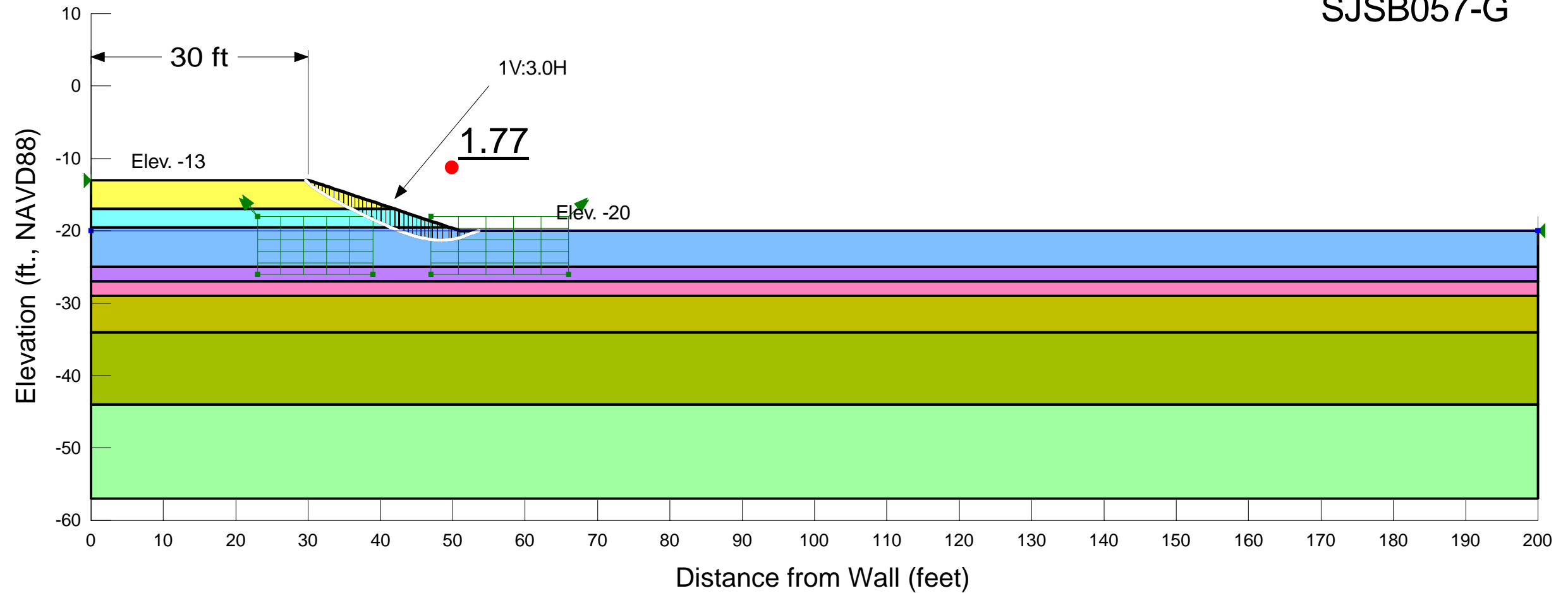

Color	Name	Model	Unit Weight (pcf)	Cohesion (psf)	Effective Cohesion (psf)	Effective Friction Angle (°)
Blue	SJSB057-G 06 - SC (-19.5 to -25)	Mohr-Coulomb	122		0	30
Purple	SJSB057-G 07 - SC (-25 to -27)	Mohr-Coulomb	122		0	30
Pink	SJSB057-G 08 - SC (-27 to -29)	Mohr-Coulomb	122		0	30
Olive	SJSB057-G 09 - CH (-29 to -34)	Undrained (Phi=0)	130	2,250		
Green	SJSB057-G 10 - CLS (-34 to -44)	Undrained (Phi=0)	135	2,250		
Light Green	SJSB057-G 11 - CH (-44 to -57)	Undrained (Phi=0)	125	2,300		
Yellow	SJSB058-G 04 - SM (-12 to -17)	Mohr-Coulomb	120		0	30
Cyan	SJSB058-G 05 - SM (-17 to -19.5)	Mohr-Coulomb	122		0	30

Notes:  
 - Piezometric line maintained at bottom of excavation  
 - Soil properties taken from individual soil boring

Analysis Name: 1V:3.0H - Spencer Block

File Name: SJSB058-G (Excavation to -20).gsz

Date: 11/30/2020

Scale: 1:200



Directory: G:\Projects\2018\18-2876 (San Jacinto Waste Pits)\Analyses\Slope\Northern Impoundment\Double Wall Offset slope stability

Method: Spencer  
 Slip Surface Option: Entry and Exit  
 Factor of Safety: 1.60

SJSB058-G  
 &  
 SJSB057-G

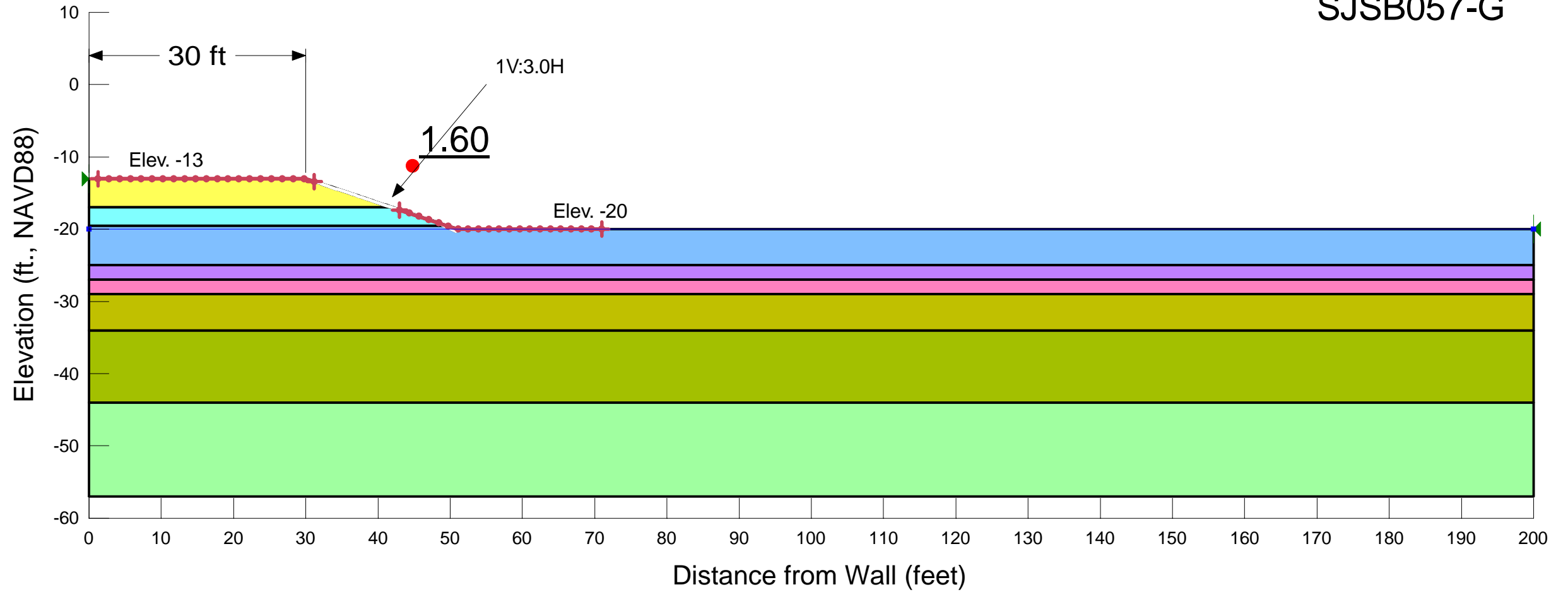

Color	Name	Model	Unit Weight (pcf)	Cohesion (psf)	Effective Cohesion (psf)	Effective Friction Angle (°)
Blue	SJSB057-G 06 - SC (-19.5 to -25)	Mohr-Coulomb	122		0	30
Purple	SJSB057-G 07 - SC (-25 to -27)	Mohr-Coulomb	122		0	30
Pink	SJSB057-G 08 - SC (-27 to -29)	Mohr-Coulomb	122		0	30
Olive	SJSB057-G 09 - CH (-29 to -34)	Undrained (Phi=0)	130	2,250		
Green	SJSB057-G 10 - CLS (-34 to -44)	Undrained (Phi=0)	135	2,250		
Light Green	SJSB057-G 11 - CH (-44 to -57)	Undrained (Phi=0)	125	2,300		
Yellow	SJSB058-G 04 - SM (-12 to -17)	Mohr-Coulomb	120		0	30
Cyan	SJSB058-G 05 - SM (-17 to -19.5)	Mohr-Coulomb	122		0	30

Notes:  
 - Piezometric line maintained at bottom of excavation  
 - Soil properties taken from individual soil boring

Analysis Name: 1V:3.0H - Spencer EE

File Name: SJSB058-G (Excavation to -20).gsz

Date: 11/30/2020

Scale: 1:200



Method: Spencer  
 Slip Surface Option: Entry and Exit  
 Factor of Safety: 1.64

SJSB058-G  
 &  
 SJSB057-G

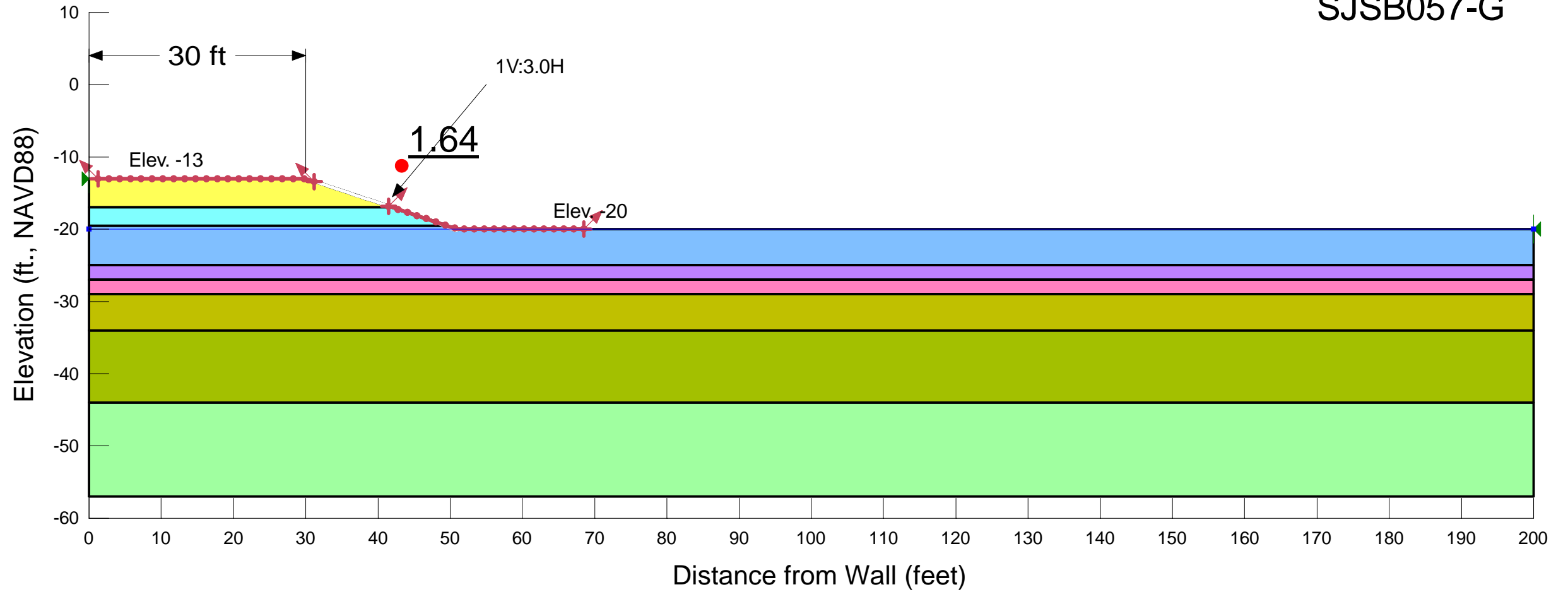

Color	Name	Model	Unit Weight (pcf)	Cohesion (psf)	Effective Cohesion (psf)	Effective Friction Angle (°)
Blue	SJSB057-G 06 - SC (-19.5 to -25)	Mohr-Coulomb	122		0	30
Purple	SJSB057-G 07 - SC (-25 to -27)	Mohr-Coulomb	122		0	30
Pink	SJSB057-G 08 - SC (-27 to -29)	Mohr-Coulomb	122		0	30
Olive Green	SJSB057-G 09 - CH (-29 to -34)	Undrained (Phi=0)	130	2,250		
Dark Olive Green	SJSB057-G 10 - CLS (-34 to -44)	Undrained (Phi=0)	135	2,250		
Light Green	SJSB057-G 11 - CH (-44 to -57)	Undrained (Phi=0)	125	2,300		
Yellow	SJSB058-G 04 - SM (-12 to -17)	Mohr-Coulomb	120		0	30
Cyan	SJSB058-G 05 - SM (-17 to -19.5)	Mohr-Coulomb	122		0	30

Notes:  
 - Piezometric line maintained at bottom of excavation  
 - Soil properties taken from individual soil boring

Analysis Name: 1V:3.0H - Spencer EE (45-deg)

File Name: SJSB058-G (Excavation to -20).gsz

Date: 11/30/2020

Scale: 1:200

Directory: G:\Projects\2018\18-2876 (San Jacinto Waste Pits)\Analyses\Slope\Northern Impoundment\Double Wall Offset slope stability





[GHD.com](http://GHD.com)

→ **The Power of Commitment**



[GHD.com](http://GHD.com)

→ **The Power of Commitment**