



EVALUATION OF GROUNDWATER TREATMENT AND WATER SUPPLY ALTERNATIVES FOR ST. LOUIS PARK, MINNESOTA

Prepared for



Minnesota Pollution Control Agency

VOLUME 1 OF 2 - SUMMARY REPORT

By

CH2M HILL
Milwaukee, Wisconsin

BARR ENGINEERING CO.
Minneapolis, Minnesota

NOVEMBER, 1983

EPA Region 5 Records Ctr.



234538



November 23, 1983

L16334.B0

Mr. Michael J. Hansel
Minnesota Pollution Control Agency
Division of Solid and Hazardous Waste
1935 West County Road B-2
Roseville, Minnesota 55113-2785

Dear Mr. Hansel:

CH2M HILL and Barr Engineering Company are pleased to submit this final report describing our evaluation of groundwater treatment alternatives at St. Louis Park, Minnesota.

Respectfully submitted,

Michael R. Harris
Project Manager

mkc/GLT345/20

RECEIVED

NOV 23 1983

MINN. POLLUTION
CONTROL AGENCY

TABLE OF CONTENTS

VOLUME 1 OF 2

| <u>Section</u> | | <u>Page</u> |
|----------------|---|-------------|
| 1 | INTRODUCTION | |
| | Background | 1-1 |
| | Purpose of Study | 1-3 |
| | Summary and Conclusions | 1-5 |
| 2 | LITERATURE SEARCH AND TECHNOLOGY ASSESSMENT | |
| | Literature Search | 2-1 |
| | Technology Assessment | 2-1 |
| | Selection of Technologies for Bench-scale Testing | 2-8 |
| | References | 2-10 |
| 3 | WELL SAMPLING AND ANALYSIS PROGRAM | |
| | Analytical Methodology | 3-1 |
| | Well Sampling and Analysis | 3-2 |
| | References | 3-7 |
| 4 | EVALUATION OF EXISTING WATER TREATMENT SYSTEM AT SLP-15 | |
| | Background | 4-1 |
| | First Round Onsite Treatment Investigation | 4-1 |
| | Bench-scale Tests | 4-1 |
| | Second Round Onsite Treatment Investigation | 4-4 |
| | Summary | 4-7 |
| | References | 4-8 |
| 5 | WATER QUALITY IN NEARBY WATER SUPPLIES | |
| | Water Supplies | 5-1 |
| | Surface Waters | 5-3 |
| | Stormwater Runoff | 5-9 |
| 6 | BENCH-SCALE TESTING PROGRAM | |
| | Introduction | 6-1 |
| | Bench-Scale Testing Results | 6-1 |
| | Comparison of Viable Technologies | 6-2 |
| | Selection of Technology for Pilot Testing | 6-13 |
| | References | 6-14 |

Handwritten notes:
Page 1-1
Page 1-3
Page 1-5
Page 2-1
Page 2-8
Page 2-10
Page 3-1
Page 3-2
Page 3-7
Page 4-1
Page 4-4
Page 4-7
Page 4-8
Page 5-1
Page 5-3
Page 5-9
Page 6-1
Page 6-2
Page 6-13
Page 6-14

Handwritten notes:
Page 1-1
Page 1-3
Page 1-5
Page 2-1
Page 2-8
Page 2-10
Page 3-1
Page 3-2
Page 3-7
Page 4-1
Page 4-4
Page 4-7
Page 4-8
Page 5-1
Page 5-3
Page 5-9
Page 6-1
Page 6-2
Page 6-13
Page 6-14

Handwritten notes:
 7
 Pilot Plant Operations
 Pilot Testing Results
 Design Criteria for Full-Scale Treatment System
 References

PILOT-SCALE TESTING PROGRAM

| | |
|---|-----|
| Pilot Plant Operations | 7-1 |
| Pilot Testing Results | 7-1 |
| Design Criteria for Full-Scale Treatment System | 7-2 |
| References | 7-4 |

EVALUATION OF ALTERNATIVE WATER SUPPLIES

| | |
|--|-----|
| Basis for Evaluation | 8-1 |
| Alternative 1 - Treat SLP-15 for Potable Water Supply and Start Up SLP-7 and -9 | 8-1 |
| Alternative 2 - Install Interconnection with City of Minneapolis Water Distribution System | 8-3 |
| Alternative 3 - Install New Wells in Mt. Simon/Hinkley Aquifer | 8-4 |
| Financial Analysis of Alternatives | 8-5 |
| References | 8-6 |

Handwritten notes:
 Basis for Evaluation
 Alternative 1 - Treat SLP-15 for Potable Water Supply and Start Up SLP-7 and -9
 Alternative 2 - Install Interconnection with City of Minneapolis Water Distribution System
 Alternative 3 - Install New Wells in Mt. Simon/Hinkley Aquifer
 Financial Analysis of Alternatives
 References

9

SELECTION OF WATER SUPPLY ALTERNATIVE FOR ST. LOUIS PARK

| | |
|---|-----|
| Introduction | 9-1 |
| Long Range Impacts on Water Supply | 9-1 |
| Recommendation for Implementation | 9-2 |
| Conceptual Design of Selected Alternative | 9-2 |
| References | 9-5 |

Handwritten notes:
 Introduction
 Long Range Impacts on Water Supply
 Recommendation for Implementation
 Conceptual Design of Selected Alternative
 References

VOLUME 2 OF 2

Project Technical Memorandums

| | |
|-----|---|
| A/B | Literature Search and Technology Assessment |
| C | Quality Assurance Project Plan |
| D | Well Sampling and Analysis Program |
| E | Investigation of Existing Treatment at Well SLP-15 |
| F | Bench-Scale Test Plan |
| H | Bench-Scale Test - Summary Report |
| I | Selection of Technology for Pilot-Scale Test Work |
| J | Pilot Testing Program |
| K | Pilot Scale Test - Summary Report |
| L | Cost Estimate for Water Supply Options for St. Louis Park |
| O/P | Evaluation of Alternative Water Supply Options for St. Louis Park, Minnesota |

LIST OF FIGURES

| <u>Figure</u> | | <u>Page</u> |
|---------------|--|-------------|
| 3-1 | Generalized Stratigraphic Sequence in St. Louis Park Area | 3-3 |
| 3-2 | Wells in Sampling and Analysis Program Middle Drift Aquifer | 3-4 |
| 3-3 | Well in Sampling and Analysis Program Platteville Aquifer | 3-5 |
| 3-4 | Wells in Sampling and Analysis Program Prairie DuChien-Jordan Aquifer | 3-6 |
| 4-1 | Flow Schematic Existing Treatment System at Well SLP-15 | 4-2 |
| 5-1 | Surface Water Quality Sampling Stations | 5-8 |
| 5-2 | Storm Water Quality Sampling Stations | 5-10 |
| 6-1 | GAC Flow Diagram | 6-5 |
| 6-2 | Ozone-UV Flow Diagram | 6-8 |
| 6-3 | Peroxide-UV Flow Diagram | 6-11 |
| 9-1 | GAC Flow Diagram | 9-3 |
| 9-2 | GAC Treatment System Site Plan | 9-4 |

LIST OF TABLES

| <u>Table</u> | | <u>Page</u> |
|--------------|--|-------------|
| 2-1 | Comparison of Technologies Potentially Applicable for Removal of PAH and other Coal Tar Derivative Compounds from Groundwater | 2-2 |
| 3-1 | Well Sampling Data Summary | 3-8 |
| 4-1 | First Round Onsite Investigation- Existing Treatment System at SLP-15 | 4-3 |
| 4-2 | St. Louis Park Well 15 - Field Data, December 17, 1982 | 4-5 |
| 4-3 | Second Round Onsite Investigation- Existing Treatment System at SLP-15 | 4-6 |
| 5-1 | Analysis of Surrounding Water Supplies- Samples Taken 11/16/82 | 5-2 |
| 5-2 | Analysis of Surrounding Water Supplies- Samples Taken 1/20/83 | 5-4 |
| 5-3 | Analysis of Surface Water Samples | 5-6 |
| 5-4 | Analysis of Stormwater Runoff Samples | 5-11 |
| 8-1 | Water Supply Alternatives-Summary of Costs | 8-7 |

GLT233/1

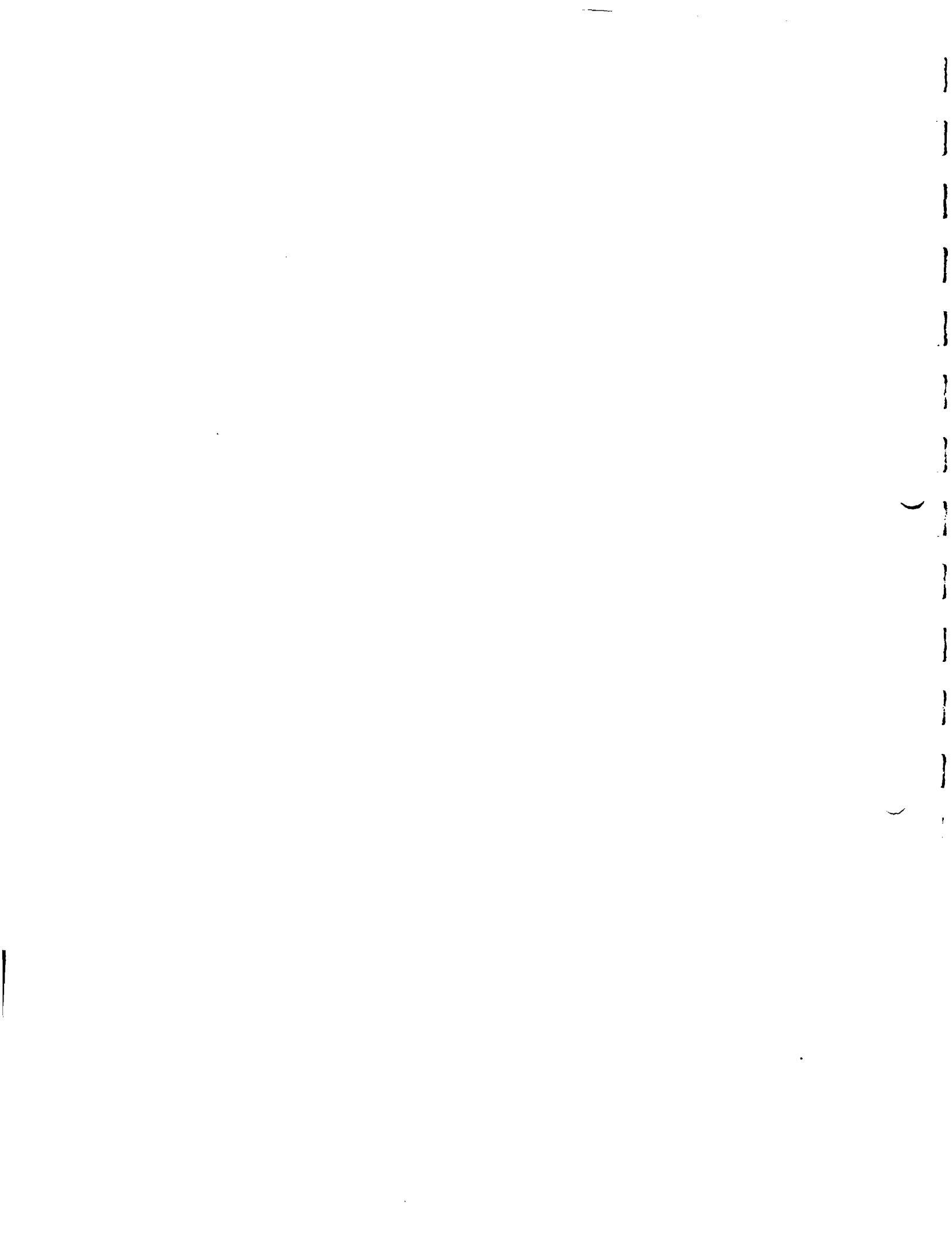

Section 1
INTRODUCTION

BACKGROUND

Early History

Reilly Tar and Chemical operated a coal tar distillation and wood preserving plant in St. Louis Park, Minnesota between 1918 and 1972. Reilly disposed of wastes from the operation in a network of ditches that discharged to a wetland adjacent to the operation. The wastes consisted of a mixture of many compounds, including a class of organic compounds known as Polynuclear Aromatic Hydrocarbons (PAH), some of which are carcinogenic.

In 1932, the first St. Louis Park municipal well was constructed. The well was shut down after several weeks of operation because of complaints about odors in the water. The odor was attributed to phenol in the water.

Throughout the 1960's and through the early 1970's, the Minnesota Department of Health (MDH) and St. Louis Park monitored municipal, commercial, and industrial wells for phenol. Phenols impart a bad taste to water, but are not believed to pose a significant health hazard at low concentrations.

In the mid 1970's, the MDH and Minnesota Pollution Control Agency (MPCA) became concerned about PAH compounds which are found in coal tar.

Groundwater Investigations and Well Closures

In 1974, St. Louis Park contracted with Gerald Sunde, a consulting engineer, to investigate pathways for movement of contaminants in the aquifers under the city. The consultant concluded that wells open to several aquifers provided a significant route for contaminant spread.

In 1975, MPCA contracted with Barr Engineering Company to conduct a study to assess the extent and magnitude of the contamination. The study concluded that the soil and shallow unconsolidated sandy aquifers near the old Reilly site were seriously contaminated and were acting as a source of contaminants to deeper bedrock aquifers. The report recommended a gradient control well network be implemented, heavily contaminated soil be removed, and the hydrology of the area be further defined.

In May 1978, the MDH was able to commence very sensitive analyses of water using High Performance Liquid Chromatography. An investigation in St. Louis Park identified PAH's present

in municipal Well Nos. 7, 9, 10 and 15. These wells, located approximately 1/4 to 1/2 mile north of the site, were subsequently closed down in 1978. (Although Well Nos. 7 and 9 did not exhibit high concentrations of PAH's, they were shut down at the same time as Wells 10 and 15 because of concerns that they would "draw" the contaminant plume toward them after Wells 10 and 15 were shut down). The next well closure occurred in December of 1979 when St. Louis Park municipal Well No. 4 was closed as a result of increasing levels of PAH. This well is located 1-1/2 miles southeast of the former Reilly site. In February of 1981 Hopkins municipal Well No. 3 was closed. This well is located 1 mile to the southwest of the former Reilly site. St. Louis Park Well No. 5 was closed in August 1981, due to increasing levels of PAH compounds. Well No. 5 is located 1/2 mile west of the site. To date, six municipal wells have been closed in St. Louis Park and one in Hopkins. The well closures in St. Louis Park accounted for over 35 percent of the city's water supply capacity. In addition, the MDH has since plugged or safely reconstructed over 29 wells in the vicinity.

All of the closed municipal wells draw from a water-bearing rock layer between 250 and 510 feet below the land surface. The water-bearing rock is known as the Prairie du Chien-Jordan aquifer. Approximately 80 percent of the groundwater utilized in the Twin Cities is from this aquifer. To date, the contamination of the Prairie du Chien-Jordan aquifer has been limited to areas below St. Louis Park and Hopkins.

In July 1978, the MDH contracted with the U.S. Geological Survey (USGS) to better define groundwater flow and organic contaminant movement in the bedrock underlying St. Louis Park. Their interpretation of the rate and mechanism for contaminant movement was then used by E.A. Hickok and Associates in 1980 and 1981 when Hickok was contracted by the State to provide additional definition of a gradient control network and a soil removal program.

Treatment Studies

During the summer of 1979, St. Louis Park conducted several studies evaluating PAH removal using powdered activated carbon (PAC). The PAC was introduced at the well head (St. Louis Park No. 15) and removed on an existing sand filter (part of an iron removal system). The results of these efforts were promising, showing good PAH removal.

In the spring of 1980, the city retained E.A. Hickok and Associates to evaluate and provide some preliminary cost estimates of various treatment alternatives [PAC, granular activated carbon (GAC), hydrogen peroxide, ultraviolet radiation] and alternative water supplies (deeper wells). Again, results with the use of PAC and GAC showed effective PAH removal (up to 95 - 99 percent). The subsequent report indicated that both GAC and PAC were effective at removing PAH. However, these studies were not designed to investigate breakthrough times, optimum carbon doses, optimum carbon medium,

minimal contact times, and effectiveness for removal at various degrees of contamination.

Remedial Action Plans

An investigation and remedial action plan for the St. Louis Park groundwater contamination problem was completed by E.A. Hickok and Associates in November 1981. The remedial action plan included a recommendation for the implementation of a gradient control well network in St. Louis Park. The gradient control network would restrict the impact of contaminant migration by controlling groundwater flow in five aquifers.

The Hickok report proposed several alternatives for gradient control under the site and further proposed three alternative discharge plans for water pumped from the gradient control network. Two of the discharge alternatives proposed by Hickok included treatment of several gradient control wells for distribution in the St. Louis Park water supply system. The remainder of the gradient control wells in the first two alternatives would be discharged to the sanitary sewer system or to the Mississippi River. The final discharge alternative proposed discharge of all gradient control water to the Mississippi River. No costs for potable water supply were included in the third alternative.

The USGS is developing a computer model of the area aquifers to predict the relative effectiveness of the various gradient control options proposed by Hickok. The model will be used to define groundwater flow and contaminant migration under several gradient control pumping schemes. Final definition of a gradient control network cannot be completed until the modelling efforts are finished.

PURPOSE OF STUDY

In August 1982, MPCA contracted with CH2M HILL to complete this evaluation of groundwater treatment and potable water supply alternatives for St. Louis Park.

The scope of this study was designed to fill in data gaps from previous studies and to provide sufficient information for the MPCA to select a groundwater treatment/potable water supply alternative for St. Louis Park. The scope of work was modified as the study progressed to compensate for new information and to effectively mesh this study with other ongoing studies by MPCA.

The objectives of this study are summarized as follows:

- o Conduct a literature search and technology assessment to summarize historical studies on the removal of PAH compounds and other coal tar derivatives

from water. The purpose of this evaluation was to select appropriate technologies for bench-scale testing work.

- o Collect and analyze water samples from several municipal water supply wells and groundwater monitoring wells in St. Louis Park. This sampling and analytical program supplemented historical data on groundwater quality and, in addition, included analysis for some compounds not included in previous test work.
- o Collect and analyze water samples at various points in the existing iron removal treatment system located near SLP-15. The purpose of this task was to determine whether the unit processes used in the treatment system are effective in the removal of PAH compounds and other coal tar derivatives.
- o Collect and analyze water samples from nearby communities to compare water quality goals for St. Louis Park with other water supplies in the area.
- o Based on the results of the above tasks, select promising treatment technologies for bench-scale testing. Collect water samples from SLP-15 and perform bench-scale test work to determine which technologies effectively remove PAH's and other coal tar derivatives. The objective of this testing program was to determine whether potable water quality can be achieved by treating contaminated water from SLP-15. The MDH established the following treatment goals for potable water:
 - 28 ng/l total concentration of carcinogenic PAH's
 - 280 ng/l total concentration of "other" measured PAH's
- o Based on the results of the bench-scale testing work, evaluate the capital and O&M costs of full-scale treatment systems using technologies which were found viable in the bench testing program. Select the most cost-effective technology for pilot-scale testing.
- o Conduct pilot-scale tests of the most cost-effective treatment technology. Scale up pilot testing results and formulate design criteria for a full-scale potable water treatment system.

- o Develop water quality and quantity goals for restoring potable water supply capacity to the city of St. Louis Park. The purpose of this task was to provide a basis for comparison of water supply alternatives.
- o Develop and evaluate water supply alternatives which will restore water supply capacity to the city of St. Louis Park. Prepare capital and O&M costs estimates for each alternative and discuss the relative advantages and disadvantages of each alternative considered.
- o Perform a cost-effective analysis of the water supply alternatives. Prepare a recommendation for implementation based on cost and technical considerations.
- o Prepare a conceptual design and Order-of-Magnitude capital and O&M cost estimates for the full-scale system.

As the study progressed, the results of individual elements of the work scope were summarized in technical memoranda. These technical memoranda were used as working documents throughout the study and are included in Volume 2 of this report.

This report represents a brief synopsis of information contained in the technical memoranda.

SUMMARY AND CONCLUSIONS

The findings of this study are summarized as follows:

1. A literature search and assessment of technologies was conducted to screen potentially applicable technologies for removal of PAH's and other coal tar derivations from groundwater. The following technologies were selected as most appropriate for bench-scale test work:
 - o Oxidation Processes
 - Ozone (O₃)
 - Ozone/Ultraviolet (O₃/UV)
 - Hydrogen Peroxide (H₂O₂)
 - Hydrogen Peroxide/Ultraviolet (H₂O₂/UV)
 - Chlorine (Cl₂)
 - Chlorine Dioxide (ClO₂)
 - o Adsorption Processes
 - Granular Activated Carbon (GAC)

- Macroreticular Resin
- o Membrane Processes
 - Reverse Osmosis (RO)
 - Ultrafiltration (U.F.)
- 2. A number of principal wells and monitoring wells in and around St. Louis Park were sampled and analyzed for PAH and other coal tar derivative compounds. Analytical results are compared to historical test work by other researchers.
- 3. SLP-15 was started up and well water was passed through the existing iron removal treatment system in September 1982. Water samples were obtained at various points in the treatment system and analyzed for PAH's. Eighty percent removal of PAH's was measured across the system, but effluent did not meet MDH's treatment goal of 280 ng/l total "other" PAH's. Based on the results of this first onsite test, additional bench-scale test work was recommended to assess the PAH removal efficiency of aeration, chlorination, filtration, and flocculation.
- 4. Bench-scale tests indicated that the unit operations employed at the existing treatment system were ineffective in removing most PAH compounds. To resolve the discrepancies between the first onsite test and the bench-scale results, a second onsite test was conducted in December 1982. The results of the second onsite test corresponded well with bench-scale results. It was concluded that the unit operations employed at the existing treatment system are not adequate to provide PAH removals for a potable water treatment system at SLP-15.
- 5. Water samples were obtained at various points in the potable water supply and distribution systems in St. Louis Park and three surrounding communities, and analyzed for PAH and other coal tar derivative compounds. St. Louis Park's existing water quality is comparable with that found in surrounding communities.
- 6. A series of bench-scale tests were conducted using water from SLP-15. The purpose of the bench-scale testing program was to identify a cost-effective water treatment technology to achieve acceptable removals of PAH and other coal tar derivative compounds. The bench-scale tests were conducted in two rounds:
 - o Round 1 was conducted under very conservative conditions (high dosages, long retention times, etc.) to quickly determine whether a given technology could achieve compliance with treatment goals.

- o Round 2 was conducted only on technologies which met the treatment goals in the first round tests and was designed to refine probable operating conditions.
7. Only three technologies tested during the bench-scale testing program met the MDH treatment goals:
 - o Granular Activated Carbon (GAC)
 - o Ozone/Ultraviolet (O₃/UV)
 - o Hydrogen Peroxide/Ultraviolet (H₂O₂/UV)
 8. Conceptual designs were prepared for full-scale treatment systems using each of the above technologies. Comparative capital and annual O&M costs were estimated for each system, as well as a discussion of the features of each system. Based on both cost and technological considerations, GAC was selected for pilot-scale testing.
 9. A 42-day pilot-scale test of GAC was conducted at SLP-15. Based on the results of the pilot test, design criteria were developed for a full-scale GAC treatment system at SLP-15. The pilot-scale test was adequate to provide system design criteria, but could not be run long enough to accurately define carbon adsorption capacity in a full-scale system. Based on information gained in bench- and pilot-scale testing, a range for expected carbon adsorption capacity was developed.
 10. To provide a common basis for evaluating water supply alternatives for St. Louis Park, the following objectives were established for each alternative under consideration:
 - o Total supply capacity of 3,400 gpm
 - 1,200 gpm year-round usage
 - 2,200 gpm "peaking" usage, three weeks per year
 - Restore pre-1978 capacity
 - o With respect to iron concentrations, water quality equivalent to pre-1978 water quality in St. Louis Park should be achieved.
 - o Attain compliance with MDH standards for PAHs.
 11. Three water supply alternatives were identified:
 - o Alternative No. 1 - Treat SLP-15 (with GAC) for Potable Supply and Start Up SLP-7 and -9.
 - o Alternative No. 2 - Install Interconnection with City of Minneapolis Water Distribution System.
 - o Alternative No. 3 - Install Wells in Mt. Simon/Hinckley Aquifer.

12. Capital and annual O&M cost estimates were prepared for each alternative. Relative advantages and disadvantages of each system are discussed. The costs of the three alternatives are summarized as follows:

| <u>Alter- native</u> | <u>Capital Cost</u> | <u>Amoritized Capital Cost</u> | <u>Annual O&M Cost</u> | <u>Total Annual Cost</u> |
|--------------------------|-------------------------|--|------------------------------------|----------------------------------|
| 1 | \$ 761,000 | \$ 76,800 | \$152,100 to 225,000 | \$228,900 to 302,500 |
| 2 | 250,000 | 25,200 | 833,000 | 858,200 |
| 3 | 1,870,000 | 188,700 | 122,000 | 310,700 |

13. Alternative No. 1 - Treatment of SLP-15 for Potable Supply and Start Up SLP-7 and -9 is recommended for implementation at St. Louis Park.

In addition to being the most cost-effective alternative for restoration of water supply capacity to St. Louis Park, the recommended alternative:

- o Provides gradient control benefits to prevent migration of the contaminant plume.
- o Provides for treatment and beneficial use of contaminated groundwater.

14. A conceptual design is presented for the recommended GAC treatment system at SLP-15.

GLT345/2

Section 2
LITERATURE SEARCH AND TECHNOLOGY ASSESSMENT

CH2M HILL conducted a search of technical literature for information to assess technologies which are applicable for the removal of PAH compounds and other coal tar derivatives from groundwater.

LITERATURE SEARCH

The literature search was conducted through both CH2M HILL's in-house technical library and two computerized data bases. The in-house literature search produced articles from recent technical journals, as well as selected publications from the U.S. EPA.

The computerized literature search was conducted by specifying key words and/or combinations of key words, e.g., "polynuclear aromatic hydrocarbons," "aromatic amine," "wood preservatives," etc.

This search produced approximately 280 sources. Each source included an abstract which was reviewed to determine if the literature was relevant to the situation at St. Louis Park. After review of the abstracts, 41 sources were reviewed in complete form, either as copies of articles or bound reports. Unless the articles related directly to treatment/removal of PAH's, they were not included in the bibliography prepared as part of the literature review.

In addition to the literature searches, equipment and chemical manufacturers were contacted for information relevant to the St. Louis Park situation.

TECHNOLOGY ASSESSMENT

Information collected during the literature search indicates that numerous types of water treatment technologies have been evaluated for PAH removal/destruction. In addition to technologies tested by others, CH2M HILL evaluated several technologies that have been, or could be, used to remove organics from water. This review was intended to summarize pertinent features of water treatment technologies and to describe the rationale for the selection of technologies for bench-scale testing.

Selected features of the water treatment technologies evaluated for St. Louis Park are summarized in Table 2-1 and described in the following paragraphs.

Table 2-1
 COMPARISON OF TECHNOLOGIES POTENTIALLY APPLICABLE
 FOR REMOVAL OF PAH AND OTHER COAL TAR DERIVATIVE COMPOUNDS FROM GROUNDWATER

| Treatment Process Type and Description | Complexity of Equip- Required | Range of Re-ported Effluent Concentrations of Selected PAH Compounds | Probability of Achievable Low ng/l PAH Concentrations | Relative Capital Cost | Relative O&M Cost | Potential Operating Problems | Types and Relative Volumes of Residues Generated | Comments |
|--|-------------------------------|--|---|-----------------------|-------------------|---|--|---|
| <u>Physical/Chemical Separation</u> | | | | | | | | |
| o Alum or Lime Precipitation | Low | -- | Nil | Low | Low | None | Large Volume of Precipitation Sludge Requiring Disposal | Not Applicable to Trace Organic Removal |
| o Filtration | Moderate | -- | Nil | Moderate | Moderate | None | Large Volume of Backwash water and Solids Requiring Disposal | Not Applicable to Soluble Organic Removal |
| o Air Stripping | Low | -- | Nil | Moderate | Moderate | Release of Vapor Bearing Off Gases | Potential Air Contamination | Not Applicable to Trace Low Volatility Organic Removal |
| o Solvent Extraction | Moderate | -- | Nil | High | High | Solvent Separation and Handling | Dilute Contaminated Solvent Requiring Treatment or Disposal | Applicable only to Gross Separation of Organics; No Known Applications for Drinking Water Treatment |
| <u>Adsorption</u> | | | | | | | | |
| o Granular Activated Carbon (GAC) | Moderate | < 1.0 ug/l to < 1.0 ng/l | High | Moderate | Moderate | Selective Compound Breakthrough | Spent Carbon Requiring Disposal or Regeneration (offsite) | Adsorption/Desorption or "Chromatographic Effect" May Allow Early Breakthrough |
| o Powdered Activated Carbon | Low | (see GAC) | High | Moderate | Moderate | Separation and Disposal of Carbon | Spent Carbon Requiring Disposal | Requires Separation Technology |
| o Nonionic Macroreticular Resin | Moderate | "100% Removal" Reported (see text) | Moderate to High | Moderate | Moderate | Resin Regeneration and Treatment of Regenerant | Dilute Regenerate Solution Requiring Treatment | Never Applied to Full-Scale Treatment System |
| o Ion Exchange | Moderate | -- | Nil | Moderate | Moderate | -- | -- | Not Applicable to Nonpolar Organic Compounds |
| <u>Chemical Oxidation</u> | | | | | | | | |
| o Ozone | High | ±2.0 ug/l | Moderate | High | High | Potential Generation of Toxic Reaction Products | None | Benzo(a)Pyrene Reported Resistant to O ₃ |
| o Hydrogen Peroxide | Low | -- | Moderate | Low | High | Potential Generation of Toxic Reaction Products | None | Reaction Chemistry Similar to Ozone |
| o Chlorine | Moderate | ±1.0 ug/l | Low | Moderate | Moderate | Potential Generation of Toxic Reaction Products | None | Chlorination Generates Chloro-Substituted PAH Compounds |

Table 2-1 (Continued)

| <u>Treatment Process Type and Description</u> | <u>Complexity of Equip- Required</u> | <u>Range of Re- ported Effluent Concentrations of Selected PAH Compounds</u> | <u>Probability of Achievable Low ng/l PAH Concentrations</u> | <u>Relative Capital Cost</u> | <u>Relative O&M Cost</u> | <u>Potential Operating Problems</u> | <u>Types and Relative Volumes of Residues Generated</u> | <u>Comments</u> |
|---|--------------------------------------|--|--|------------------------------|--------------------------------------|--|--|--|
| o Chloride Dioxide | High | < 0.01 ug/l | Moderate | High | Moderate | Gas Reported React- iver and Unstable. Potential Generation of Toxic Reaction Products | None | Chlorination Oxidation Generates Chloro-Substituted PAH Compounds |
| o Ozone with UV | High | ±2.0 ug/l | High | High | High | Potential Generation of Toxic Reaction Products | None | UV Radiation Reportedly Reduces Reaction Time Required Compared to Ozone Alone |
| o Hydrogen Peroxide with UV | High | < 100 ug/l | High | High | High | Potential Generation of Toxic Reaction Products | None | UV Radiation Promotes Hydroxyl Radical Formation |
| <u>Membrane Separation</u> | | | | | | | | |
| o Reverse Osmosis | Moderate | -- | High | High | High | Membrane Fouling | Moderate to High Volume Reject Stream Requiring Separate Treatment | Pretreatment Required to Minimize Membrane Fouling. No Operating Data on PAH Removal Available |
| o Ultrafiltration | High | -- | Low | Moderate | Moderate | Membrane Fouling | Small Volume Reject Stream Requiring Separate Treat- ment | Low Probability of Removing PAH's but Offers Significant Process Advantages |
| o Electrodialysis & Dialysis | High | -- | Nil | High | High | -- | -- | Not Applicable to Nonpolar Organic Compounds |
| <u>Biological Treatment</u> | | | | | | | | |
| o Activated Sludge and Similar Biological Processes | Moderate | 0.28 to 0.04 ug/l Wastewater Treat- ment Applications | N.A. | Moderate | Moderate Low Organic Applicable Only | Cannot Operate on Concentration; to Wastewater | Waste Biological Growth | Not Applicable to Low Organic or Potable Water Treatment |

Physical/Chemical Separation

Chemical precipitation with alum or lime is generally used for the removal of suspended solids and certain ionic chemicals from water. There are several reports of some PAH removal by alum or lime precipitation followed by settling and filtration. In these cases, PAH removal probably occurs by adsorption of the organic molecules to the inorganic precipitate and/or removal of PAH's associated with particulates. Alum or lime precipitation is not considered applicable to the removal of trace organics dissolved in groundwater. However, chemical precipitation could potentially be required as part of a pretreatment process upstream of other unit operations.

Similarly, filtration, alone or following chemical precipitation, is not applicable to the removal of trace soluble organics, but might be considered as a treatment process to remove the fraction of PAH's associated with particulates. Filtration might also be considered in combination with an adsorption process where it might be used to separate adsorbent from the treated water.

Air stripping is used to separate relatively volatile pollutants from dilute water solutions. Air stripping has been used for industrial wastewater treatment on pollutants such as phenols, mercaptans, and chlorinated hydrocarbons. From an examination of the vapor pressure and Henry's constants for PAH's, however, it is clear that the majority of PAH compounds, especially the carcinogenic species, are not easily removed by air stripping. Therefore, air stripping was not considered applicable for the removal of trace, low-volatility organics and was not considered further.

Solvent extraction dissolves organic pollutants from water by mixing the water with an organic solvent into which the pollutant will preferentially dissolve or partition. Solvent extraction is economically feasible in cases where recovery of a valuable product is possible but has never been applied to water supply treatment. This technology was dropped from further consideration.

Adsorption

Activated carbon has found widespread application in the treatment of drinking water for the removal of trace concentrations of organics. Generally, activated carbon is most effective for organic pollutants having high molecular weight, and low water solubility, polarity, and degree of ionization. It has been reported as an effective adsorbent for polynuclear aromatic hydrocarbons.

Numerous studies have reported data on the performance of activated carbon for removal of pure compounds dissolved in clean water. However, the performance of activated carbon for mixtures of organic pollutants is somewhat unpredictable because of preferential or competitive adsorption behavior.

Activated carbon is available in granular or powdered form. The major difference between powdered and granular activated carbon is the equipment required to handle the carbon. Unlike granular activated carbon, which is held within a contacting column, powdered activated carbon (PAC) is mixed into the flowing water stream and requires a separation process such as sedimentation to remove the carbon from the treated water. Furthermore, more powdered carbon is required to achieve the same removals that granular activated carbon achieves. Granular activated carbon has been the subject of a great deal of research for the removal of PAH's and was considered to have a high likelihood of achieving desired effluent goals.

Previous researchers at St. Louis Park experimented with PAC treatment by injecting PAC at the well head of SLP-15 and removing the carbon on the existing sand filters. When the filters were backwashed, spent carbon was flushed to the backwash settling basin, allowed to settle, and then pumped to the sanitary sewer system. Although this arrangement worked fairly well on an experimental basis it would not be appropriate for a long term operation.

Direct application of PAC onto sand filter beds is inadvisable in a permanent installation because:

- o Head loss across the filters would increase, probably requiring more frequent backwashing
- o PAC fines would likely pass through the sand filter beds and end up in the City's potable water distribution system
- o Disposal of spent carbon with filter backwash solids may be inappropriate because:
 - Increased abrasion (and maintenance) on sludge pumping equipment
 - Potential sedimentation/plugging of sewer piping

If a full scale PAC system were to be considered, the system would require:

- o A carbon slurry and feed system
- o A carbon contact tank with mixer

- o A carbon clarifier
- o A flocculant mixing and feed system to enhance carbon sedimentation
- o Spent carbon slurry pumps and a spent carbon storage/disposal system
- o A booster pump station to deliver treated water to the sand filters
- o A building addition to house the above equipment

In comparison, a GAC system would consist of pressurized carbon contact vessels which could be placed in-line using the existing well pump.

CH2M HILL elected to concentrate on GAC rather than PAC because:

- o A properly designed PAC system would be comparable in capital cost to a GAC system.
- o To achieve comparable effluent water quality, a PAC system would require higher carbon dosage (and, therefore, costs)
- o A PAC system would have more operator duties (mixing carbon, mixing flocculant, pump adjustments, etc.)
- o A PAC system would have more pieces of equipment requiring maintenance
- o A PAC system would be more prone to operator error (i.e. forgetting to mix carbon or flocculant)
- o A PAC system depends on constant addition of carbon to effectively remove contaminants. A short term failure of the carbon delivery system could result in untreated water being discharged to the water distribution system. A multiple reactor GAC system would have a tremendous "reserve" of unspent carbon, making it far less susceptible to short term problems.
- o A PAC system would probably require more frequent analysis of influent and effluent water quality to ensure proper product water quality.
- o A PAC system would probably require flocculant, thereby increasing O & M cost.

Synthetic resins are also used to separate organic compounds from water. These resins are typically a hydrophobic

material such as a polystyrene co-polymer which is very porous and adsorbs nonionic and relatively insoluble organic pollutants such as PAH compounds and other aromatic organics. When the resin capacity is exhausted, the resin must be regenerated chemically or discarded. Although these resins are chemically similar to ion exchange resins, they are nonionic.

Ion exchange processes utilize charged resins to preferentially remove ionic species. Removal of specific ions depends on resin chemistry and regeneration methods. Ion exchange, as such, is not applicable because PAH compounds are nonionic and relatively nonpolar.

Chemical Oxidation

Chemical oxidation of organics in water involves a chemical reaction between the organic molecule and an oxidizing chemical. The reaction may oxidize the original organic molecule to a harmless compound, or may generate a different compound, possibly even more toxic than the original material, depending on the original molecule, the type of oxidant used, and reaction conditions.

Ozone (O_3) is the triatomic form of oxygen (O_2). Ozone's chemical structure is inherently unstable and results in powerful oxidizing potential. Ozone has approximately 1.5 times the oxidizing potential of chlorine. Oxidation of organics in water by ozone is normally carried out in a contact tank similar to a chlorine contact basin in which ozone is bubbled through a diffuser system.

Recent developments in ozone-generating equipment have reduced operating costs of ozonation to near that of other chemical oxidants, but capital costs associated with an ozonation system are high. Ozone must be generated at the point of use.

Hydrogen peroxide (H_2O_2) is a strong oxidant frequently used in the chemical industry and in waste treatment. The effectiveness of hydrogen peroxide on organics other than phenol is not well reported.

Chlorine (Cl_2) is perhaps the most commonly used oxidizing agent for wastewater treatment in the United States. The technology of chlorine shipment, handling, measurement, and application is well established and relatively reliable. PAH removals have been reported in a number of full-scale water treatment plants employing chlorination. Available data, however, do not define how much of the removal is attributable to physical removal of solids rather than oxidation of soluble PAH's.

The use of chlorine to oxidize PAH compounds may generate a variety of chlorinated aromatic and aliphatic compounds. These oxidation end-products may also require removal because of their known or suspected toxicity.

Chlorine dioxide has been used experimentally to oxidize PAH and phenolic compounds in water. Chlorine dioxide is an unstable gas which, like ozone, must be generated onsite. Several chlorinated reaction products have been identified from the oxidation reaction of PAH compounds with ClO_2 .

Ozone has been used in combination with ultraviolet (UV) radiation for oxidation of organics in water. The UV radiation enhances the formation of chemical species which have a higher oxidation potential than ozone alone. This technology was judged to have the potential of being superior to ozone in oxidation performance while retaining the advantage over chlorine of no formation of chlorinated reaction products.

Oxidation of organics in wastewater by hydrogen peroxide (H_2O_2) and UV radiation has also been reported. A proprietary process by Enercol, Inc., utilizes cavitation shock, an organic catalyst, and UV radiation to form hydroxyl radicals (OH^\cdot) from hydrogen peroxide. The hydroxyl radicals are a very powerful oxidizing species which react with organic molecules, especially by reaction with single hydrogens on the carbon chain or ring. No specific performance data on the oxidation of PAH compounds with this process are available. Like ozone, hydrogen peroxide with UV radiation was judged to have the potential of being an effective oxidizing system without the problem of chlorinated reaction products.

Other oxidants include permanganate, chromate, bromine, and persulfuric acid. None of these chemicals were considered suitable for further investigation.

Membrane Separation

Several membrane processes were reviewed. Reverse osmosis (RO) involves the application of external pressure to a solution in contact with a semipermeable membrane. The pressure forces water through the membrane while soluble and insoluble constituents such as organic molecules are excluded or "rejected." Reverse osmosis may be thought of as an extremely fine filter which allows water and similar small molecules to pass but retains larger molecules dissolved in the solution.

Reverse osmosis has been reported in the literature to remove a wide variety of soluble organics from water. No data were found to document removal rates for PAH's, but based on the size of PAH molecules, it is likely that removal rates would be high. RO is a proven technology in use for both industrial production and waste treatment.

Ultrafiltration is similar to reverse osmosis except that the membrane pores are larger and the operating pressures are lower. No reports of ultrafiltration applications for the removal of trace organics could be found. Based on pore size, ultrafiltration is not likely to be effective on dissolved PAH molecules, which have an approximate molecular size of 10^{-6} mm. Unless the PAH molecules agglomerate and form micelles, PAH compounds are likely to pass through the ultrafiltration membrane. However, ultrafiltration does offer the process advantage of a small "reject" water flow relative to RO.

Electrodialysis and dialysis are both membrane separation processes. In electrodialysis, the membrane acts as a selective separation barrier or "sieve" while the driving force is electric potential. Electrodialysis is applicable for separation of charged ions but is not applicable for the separation of nonionic organic compounds. In dialysis, the membrane also acts as a selective solute barrier while the driving force is a concentration difference. Dialysis is applied where large concentration differences can be set up to recover relatively small ions or molecules, not for separation of extremely dilute, high molecular weight organic compounds.

Biological Treatment

Activated sludge is a commonly used method of wastewater treatment. It consists of a mass of various microorganisms, clustered in small particles, and suspended in aerated wastewater, which consume organic matter in the wastewater. Activated sludge is not applicable for St. Louis Park because the concentration of organics in the water is far too low to support the quantity of organisms required to operate a treatment system.

SELECTION OF TECHNOLOGIES FOR BENCH-SCALE TESTING

Technologies selected for bench-scale testing were divided into three categories:

- o Category 1. Demonstrated technologies with high probability of success and no known reaction products requiring treatment.
- o Category 2. Demonstrated technologies with good probability of success but yielding reaction products or residue requiring further treatment.
- o Category 3. Attractive technologies, not demonstrated, with a low probability of success but major potential process advantages.

Category 1 Technologies

These technologies include oxidation and adsorption processes.

Oxidation

Ozone and hydrogen peroxide, both alone and with ultraviolet radiation were considered for bench-scale testing. Both oxidation processes have been shown to oxidize organics dissolved in water. Further, neither technology produces chlorinated reaction products which could require further treatment. These oxidation systems may produce other reaction products, of which the toxicity is not presently known or reported.

Adsorption

Granular activated carbon is known to remove PAH's from water. Thermal regeneration of granular activated carbon destroys adsorbed organics and yields a carbon ready for reuse without generating a residue or sludge requiring further treatment.

Category 2 Technologies

These technologies include oxidation, membrane separation and adsorption processes.

Oxidation

Category 2 oxidation processes considered for bench-scale testing were chlorination and chlorine dioxide. Both processes are known to oxidize PAH compounds. However, both reaction processes are also known to produce a variety of chlorinated reaction products which may also be toxic and require further treatment for removal.

Membrane Separation

Reverse osmosis (RO) was considered in Category 2 because it is likely to work but generates a relatively concentrated waste or "reject" stream which contains the organic pollutants and may be as large as 20 percent of the total flow through the treatment system. If conventional oxidation and adsorption technologies achieve adequate PAH removals, RO was judged to be too expensive for further consideration.

Adsorption

The adsorption technology selected in Category 2 was synthetic resin adsorption, which is reported to be effective in removing high concentrations of PAH compounds. However, resins require either disposal or regeneration after their adsorptive capacity is exhausted. Regeneration requires a solvent to

remove adsorbed organics. This regenerant constitutes a contaminated residue requiring final disposal.

Category 3 Technologies

Under Category 3, the only technology considered was ultrafiltration. As discussed previously, ultrafiltration is not likely to be effective on dissolved PAH molecules which have an approximate molecular size of 10^{-6} mm. However, ultrafiltration generates a very small "reject" stream relative to RO. If ultrafiltration at the smallest pore size is effective, it would present the advantage of a smaller "reject" stream than RO.

Since bench testing of ultrafiltration is performed using the same general test apparatus as RO, it appeared prudent to run some tests of ultrafiltration even though the probability of success was judged to be low.

REFERENCES

Material discussed in this section is presented in detail in Technical Memorandum A/B. Specific recommendations for bench-scale testing work are included in Technical Memorandum F.

GLT345/13

Section 3
WELL SAMPLING AND ANALYSIS PROGRAM

ANALYTICAL METHODOLOGY

Groundwater under St. Louis Park contains trace concentrations of Polynuclear Aromatic Hydrocarbons (PAH) and other coal tar derivative compounds. The degree of groundwater contamination in various municipal and/or monitoring wells ranges from a few nanograms per liter (parts per trillion) to several micrograms per liter (parts per billion). One monitoring well located in the bog area south of the former Reilly site contains several thousand milligrams per liter (parts per million) of PAH compounds.

Since 1978, when the MDH began a very sensitive groundwater analysis using High Performance Liquid Chromatography (HPLC), a number of researchers have measured PAH compounds in groundwater samples from the St. Louis Park area. Prior to this study, analytical work was conducted with HPLC and Selective Ion Monitoring (SIM) techniques using Gas Chromatography/Mass Spectroscopy (GC/MS). Both of these techniques yield detection limits of parts per trillion for specific compounds, but analyses were limited to specific compounds "targeted" by the various laboratories. During the course of historical test work, different compounds have been "targeted" by different laboratories.

During the early phases of this study, CH2M HILL developed a modified GC/MS testing protocol which permits identification of all base neutral compounds in the low nanogram per liter range. The method developed is a modification of EPA Method 625 and is described in detail in Technical Memorandum C in Volume 2 of this report.

Before analytical test work was begun on water samples from St. Louis Park, CH2M HILL's laboratory conducted a Method Validation Study under the direction of EPA's Environmental Monitoring and Support Laboratory in Cincinnati, Ohio. This study confirmed the validity of the new test procedures and established Method Detection Limits (MDL) for a number of compounds to be targeted by CH2M HILL during this study. The list of target compounds was established by MPCA and EPA prior to the Method Validation Study and includes six carcinogenic PAH, 14 "other" PAH, five nitrogen heterocycles, one sulfur heterocycle, and three miscellaneous compounds.

Chromatograms from all analyses conducted during this study are permanently filed for recall on CH2M HILL's computer. If quantification of nontarget compounds is desired at some future date, method detection limits can be established for additional compounds and the tapes recalled for analysis.

(On two occasions during this study, tentative identifications were made of all major nontarget peaks in chromatograms. See Technical Memorandum D.)

WELL SAMPLING AND ANALYSIS

St. Louis Park is underlain by a number of aquifers. Figure 3-1 illustrates the stratigraphic sequence in the area. Figures 3-2, 3-3, and 3-4, illustrate the locations of wells sampled and analyzed by CH2M HILL during this study.

During each of two sampling rounds, water samples were drawn from each well (monitoring Well No. W13, located in the bog area south of the Reilly Site was sampled only in the first round) and shipped to CH2M HILL's laboratory in Montgomery, Alabama.

Additional samples were obtained from SLP-15 during analysis of the existing iron removal system and during bench- and pilot-scale test work, as described in Sections 4, 6, and 8.

All well water samples were analyzed for the base neutral compounds listed in Technical Memorandum C. Following the first round of sampling, three aromatic amines (aniline, 1-aminonaphthalene, and 2-aminobiphenyl) and one oxygen heterocycle (dibenzofuran) were added to the list of compounds targeted in analysis. These compounds represented the 3 highest concentration aromatic amines and the single highest concentration oxygen heterocycle found in water drawn from W13 in the first round of sampling.

In addition to PAH analyses, several well water samples were analyzed for acid fraction compounds, total organic carbon, volatile compounds, and selected inorganic compounds. Acid and volatile compounds were generally absent. TOC in well water samples ranged from 4 to 10 mg/l. The concentrations of inorganic compounds were comparable with historical tests in the area. These miscellaneous tests are described in detail in Technical Memorandum D.

MPCA provided CH2M HILL with all available historical PAH analyses on water samples from the same wells sampled during this study. In addition, several analyses were conducted by EPA and/or Monsanto on samples split with CH2M HILL. All analyses were summarized in chronological order to compare CH2M HILL's results with historical test work and to assess trends in water quality. These data summaries are presented in Attachment D-4 in Technical Memorandum D.

Due to differences in testing procedures, it is inappropriate to directly compare CH2M HILL's analytical results with those of other laboratories, especially when comparing total detected concentrations of PAH compounds. Where specific compounds are reported by several laboratories, however, the results can be compared, subject to differences in testing procedures. Available data indicates that the analytical

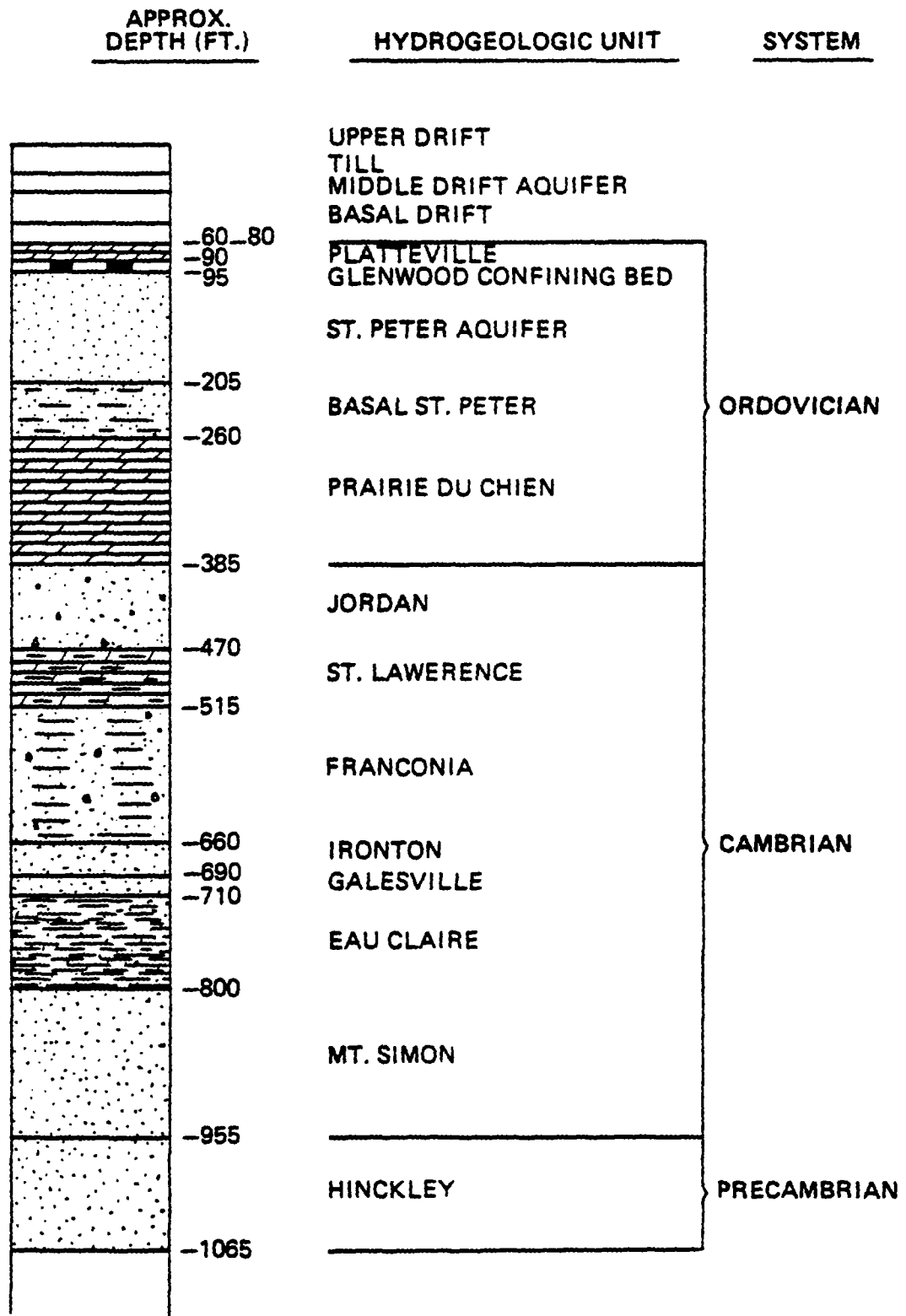

Figure 3-1
Generalized Stratigraphic Sequence
in St. Louis Park Area

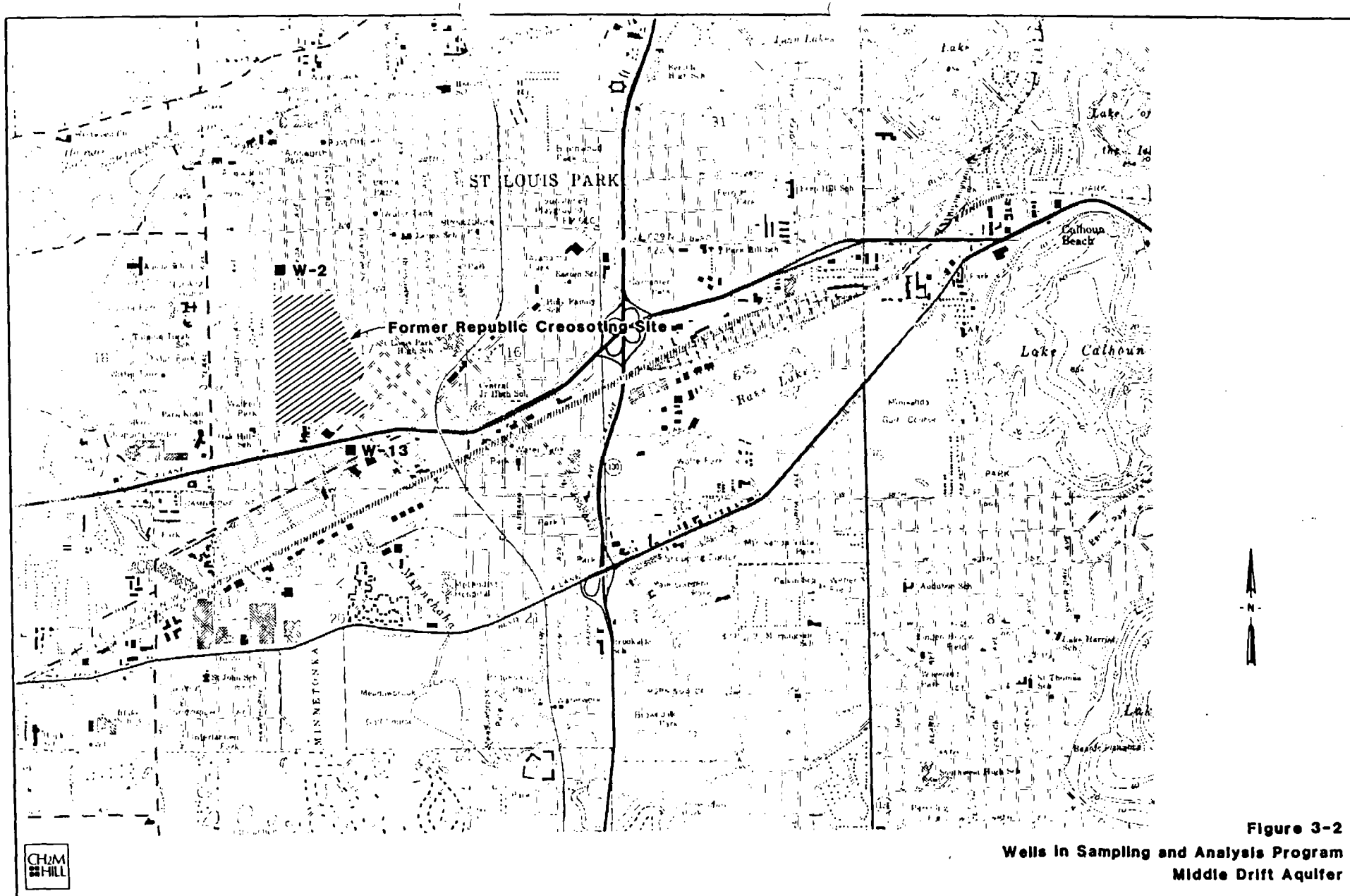

Figure 3-2
Wells in Sampling and Analysis Program
Middle Drift Aquifer

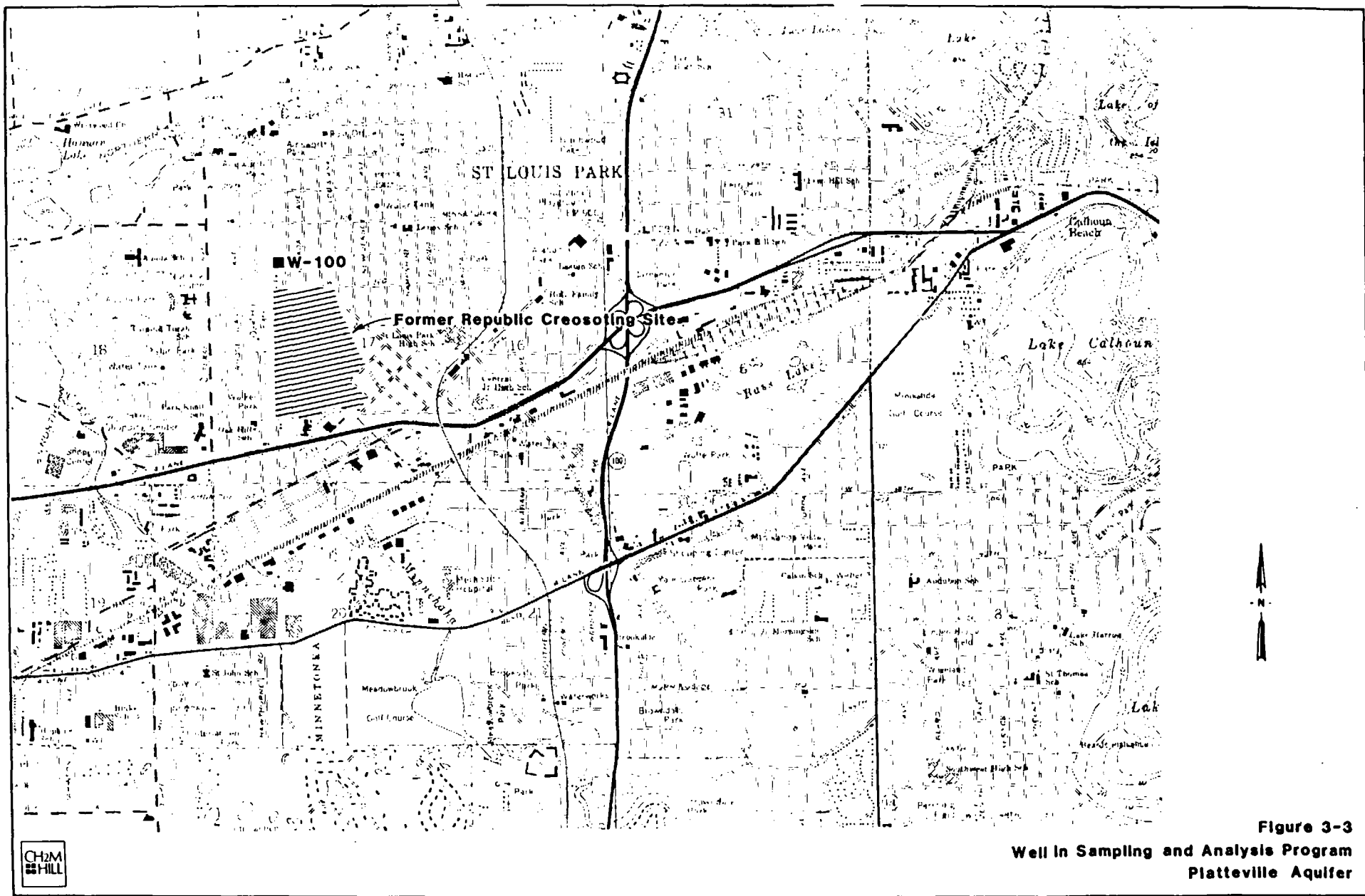

Figure 3-3
 Well in Sampling and Analysis Program
 Platteville Aquifer



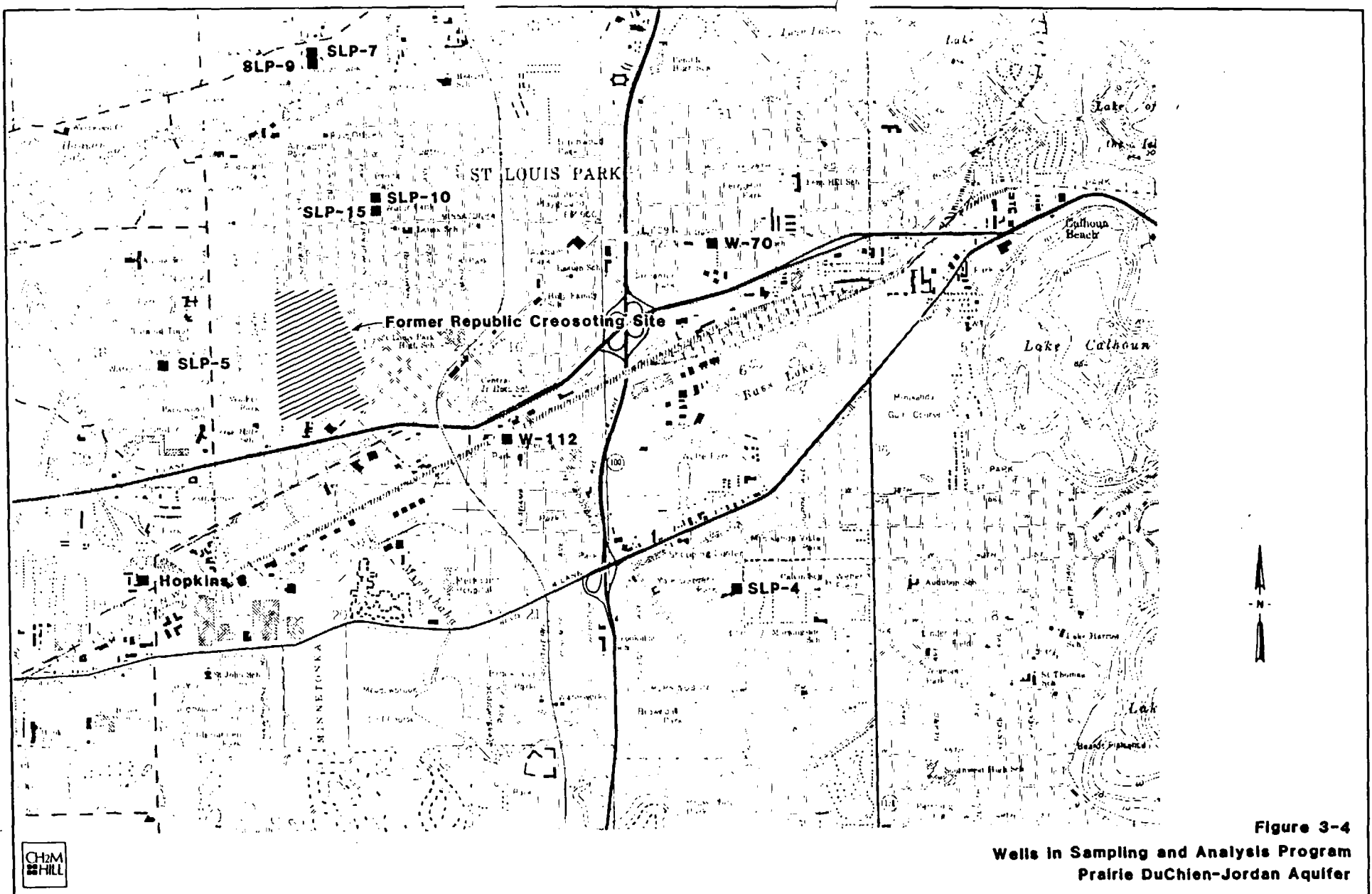

Figure 3-4
Wells in Sampling and Analysis Program
Prairie DuChien-Jordan Aquifer

technique used by CH2M HILL yields similar results to those reported by other laboratories. The data suggest that HPLC techniques are more sensitive to high molecular weight compounds and less sensitive to the low molecular weight compounds. Data from other laboratories using SIM GC/MS techniques are similar to those reported by CH2M HILL, especially if data are corrected for percent recovery of surrogate spiking compounds.

Table 3-1 summarizes well water PAH analyses conducted by CH2M HILL during this study. Whenever data obtained during this study are substantially different than historical data, a discussion of water quality trends is included.

REFERENCES

The material discussed in this section are presented in detail in Technical Memoranda C and D.

GLT345/4

Table 3-1
WELL SAMPLING DATA SUMMARY
(CH2M HILL Data Only)

| Well No. | Aquifer | No. Samples Analyzed by CH2M HILL | CH2M HILL DATA ONLY | | | | | | Comments |
|-----------|-------------------------------|---|--------------------------|------|-------------------|-------------------|-------|-------------------|--|
| | | | Carcinogenic PAH's, ng/l | | | Total Other PAH's | | | |
| | | | Low | High | Average | Low | High | Average | |
| W2 | Middle Drift | 2 | 0 | 0 | 0 | 18 | 32 | 25 | Concentrations are lower than reported by MRI in February 1981. This well is relatively uncontaminated. |
| W13 | Middle Drift | 1 | - | - | 1.6×10^8 | - | - | 2.6×10^9 | Water in this well (located in the bog area south of the Reilley site) is extremely contaminated. Liquid pumped from well is a 2-phase mixture of water and cresote-like material. |
| W100 | Platteville | 2 | 0 | 2.5 | 1.25 | 0 | 19.2 | 9.6 | No contamination is apparent in this well. |
| Hopkins 3 | Prairie du Chien Jordan | 2 | 0 | 0 | 0 | 63.1 | 111.7 | 87.4 | This well appears to be relatively clean with only minor concentrations of PAH's (no carcingens). Concentrations of PAH's are substantially lower than detected in early 1981 when the well was shut down. |
| SLP-4 | Prairie du Chien Jordan | 8 | 0 | 0 | 0 | 222 | 436 | 319 | PAH concentrations were relatively stable from 5/82 through 11/82. The well is contaminated slightly above MDH goal of 280 ng/l total "other" PAH's. This well does not have an iron removal system, but could potentially be started up and meet treatment goals if an iron removal system were installed and excess Cl_2 (or ozone) used as an oxidant. (see tech memos E and H for PAH removal by oxidation.) Startup of this well, however, would not meet water supply goals (see tech memo O/P) without supplemental supplies of water for peaking capacity. |

Table 3-1 (Continued)

| Well No. | Aquifer | No. Samples Analyzed by CH2M HILL | CH2M HILL DATA ONLY | | | | | | Comments |
|----------|-------------------------------|---|--------------------------|------|---------|-------------------|--------|---------|--|
| | | | Carcinogenic PAH's, ng/l | | | Total Other PAH's | | | |
| | | | Low | High | Average | Low | High | Average | |
| SLP-5 | Prairie du Chien Jordan | 2 | 0 | 0 | 0 | 3,253 | 17,416 | 10,335 | CH2M HILL's analyses, as well as historical analyses indicate wide fluctuations in water quality at this well. This could be due to its proximity to the site and varied stresses on the aquifer. Insufficient information is available to draw conclusions. |
| SLP-7 | Prairie du Chien Jordan | 3 | 0 | 0 | 0 | 75.4 | 122.9 | 101 | This well does not appear to be heavily contaminated at this time. Only one historical analysis (7/81) exceeded MDH water quality goals. |
| SLP-9 | Prairie du Chien Jordan | 5 | 0 | 0 | 0 | 50.6 | 91.2 | 73 | This well does not appear to be heavily contaminated. No historical analyses have exceeded MDH water quality goals. |
| SLP-15 | Prairie du Chien Jordan | 15 | 0 | 34 | 21.5 | 5,089 | 8,184 | 7,047 | This well exhibited high and fairly uniform levels of PAH throughout the period of this study. The lowest PAH concentrations were measured on the 2nd day of a pump test by ERT, the highest concentrations during CH2M HILL's pilot studies when pumping rates were very low. |
| W70 | Prairie du Chien Jordan | 2 | 0 | 16.6 | 8.4 | 2,070 | 2,221 | 2,145 | This well exhibited moderate and stable concentrations of PAH contamination. |
| W112 | Prairie du Chien Jordan | 2 | 0 | 0 | 0 | 33 | 79 | 56 | This well is only slightly contaminated with PAH's. |

Section 4
EVALUATION OF EXISTING WATER TREATMENT SYSTEM AT SLP-15

BACKGROUND

Two of the municipal wells in St. Louis Park (SLP-10 and -15) which have been shut down were formerly served by an iron removal water treatment plant.

Figure 4-1 illustrates a simplified schematic treatment process at the water treatment system at SLP-15 (and SLP-10). The iron removal facility is currently operational, serving SLP-3 and SLP-11 which are not contaminated with PAH's.

One of the goals of this study was to determine whether the unit processes employed at the existing treatment plant (chlorination, aeration, flocculation, filtration) are effective in removing PAH compounds.

FIRST ROUND ONSITE TREATMENT INVESTIGATION

On September 15, 1982, SLP-15 was started up and contaminated water was passed through the treatment system (SLP-3 and -11 were shut down for the duration of the test). Grab samples at intermediate points in the treatment system were obtained for analysis.

Table 4-1 illustrates PAH concentrations found during this round of testing.

The laboratory staff reported that two of the samples "contained considerable particulate matter which had the appearance of carbon." (Powdered activated carbon (PAC) has been injected at SLP-15 several times in the past, but had not been added for some time prior to this test. SLP-11 discharges into the same pipeline as SLP-15 and had been run continuously since the last PAC addition.) Although it is possible that the particulates noted by the laboratory staff were carbon, no explanation is readily apparent for why it appeared during this test.

The first round of investigation of the existing iron removal system at SLP-15 was very promising. Although the MDH goal of 280 ng/l total "other" PAH's was not met, approximately 80 percent removal of PAH compounds was measured across the system.

BENCH-SCALE TESTS

After the first round of investigation at the existing treatment system at SLP-15, CH2M HILL recommended additional bench-scale tests to define the mechanism of PAH removal in the

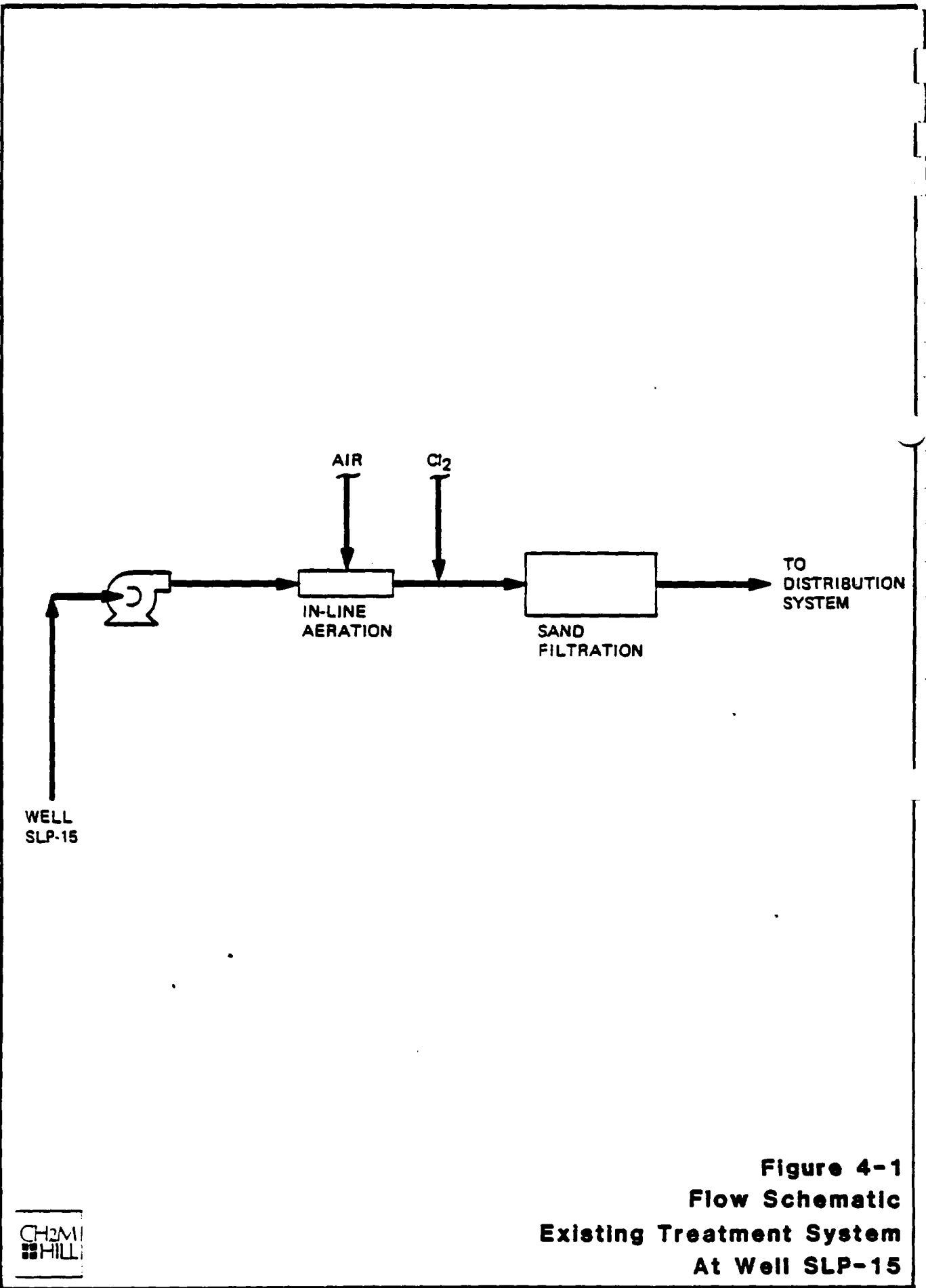

Figure 4-1
Flow Schematic
Existing Treatment System
At Well SLP-15



Table 4-1
FIRST ROUND ONSITE INVESTIGATION
EXISTING TREATMENT SYSTEM AT SLP-15

| <u>Sample Locations</u> | <u>Total "Other" PAH^a, ng/l</u> |
|--|--|
| SLP-15 Wellhead | 6,610 |
| After Aeration | 3,329 |
| After Aeration and Chlorination | 2,698 |
| 2 Days after Aeration, Chlorination, and Filtration | 1,172 |
| 5 Days after Aeration, Chlorination and Filtration | 879 |

^a During this early round of test work, the laboratory did not concentrate the samples to the degree necessary to achieve extremely low PAH detection limits. Because the detection limits were higher than in later tests, no carcinogenic PAH's were detected.

GLT233/10

existing treatment system (see Technical Memorandum F). Although similar knowledge could have been gained from extended test work at the full-scale treatment system, it was believed that closely controlled bench-scale tests would be more appropriate to define removal mechanisms and to gain a better understanding of which unit operations actually achieve PAH removals.

As a part of the bench-scale testing program, aeration, chlorination, flocculation, and filtration were tested (see Section 6). In contrast to the results of the first round of testing at the existing treatment system, PAH removals measured in the laboratory were relatively poor. Only chlorination (at high dosages) resulted in significant PAH removal, but still did not achieve compliance with the MDH goal of 280 ng/l for total "other" PAH compounds.

Because of the discrepancies between the first round of field testing and the results of the bench testing program, a second round of field testing at the existing treatment system was recommended.

SECOND ROUND ONSITE TREATMENT INVESTIGATION

The purpose of the second round onsite investigation (conducted on December 17, 1982) was to resolve the discrepancies between the first round onsite investigation and subsequent bench-scale tests.

During the second round investigation, the following samples were collected:

- o SLP-15 at wellhead
- o Sample immediately upstream from aeration
- o Sample after aeration and chlorination (with standard air and chlorine injection rates)
- o Sample at the sand filter outlet (with standard air and chlorine injection rates)
- o Sample at the sand filter outlet (with air and chlorine gas flows turned off)
- o Sample after chlorination and aeration (with maximum air and chlorine injection rates and with pressure in the system elevated)

Table 4-2 summarizes the conditions for each of the above samples. Table 4-3 summarizes analytical test results from the second round investigation.

Table 4-2

ST. LOUIS PARK WELL 15
 FIELD DATA
 December 7, 1982

| <u>Time</u> | <u>Location</u> | <u>Aeration % of Full Scale Air Flow*</u> | <u>Chlorine Set Point (lbs/day)</u> | <u>Pressure at Filter Inlet (lbs/sq in)</u> | <u>Dissolved Oxygen mg/l</u> | <u>Samples Collected</u> |
|-------------|---------------------|---|---|---|--------------------------------------|------------------------------|
| 0830 | Well Head Sample 1 | -- | -- | -- | -- | 3 2L PAH |
| 1145 | Filter Outlet Bed 3 | 0 | 0.0 | 9.9 | 0.2 | 1 2L PAH |
| 1347 | Air Inlet | -- | -- | -- | -- | 1 2L PAH |
| 1348 | Filter Inlet | 20 | 15 | 10 | -- | 1 2L PAH |
| 1349 | Filter Outlet Bed 1 | 20 | 15 | 10 | 1.5 | 1 2L PAH |
| 1845 | Filter Inlet | 100 | 80 | 18 | 0.8 | 1 2L PAH |

* Full scale air flow = 6.07 SCFM

GLT207/45-2

Table 4-3
 SECOND ROUND ONSITE INVESTIGATION
 EXISTING TREATMENT SYSTEM AT SLP-15

| <u>Sample Location</u> | <u>Total Carcinogenic PAH, ng/l</u> | <u>Total "Other" PAH, ng/l</u> |
|---|---|------------------------------------|
| SLP-15 Wellhead | 20.3 | 5,266 |
| Before Aeration | 20.2 | 5,120 |
| After Aeration & Chlorination (Standard O ₂ & Cl ₂) | 18.5 | 4,568 |
| After Aeration, Chlorination & Filtration (Std. O ₂ & Cl ₂) | -- ^a | 4,697 |
| After Filtration (No O ₂ Cl ₂) | -- ^a | 4,888 |
| After Aeration Chlorination & Filtration (Max. O ₂ , Cl ₂ & Pressure) | -- ^a | 1,930 |

^aAll carcinogenic PAH's were below method detection limits.

GLT233/14

The results of the second round investigation correspond well with the results of the bench-scale laboratory tests. Results of the second round indicate:

- o A slight decrease in total PAH concentration occurred during contact with air and chlorine at standard gas flow rates.
- o Removal of noncarcinogenic PAH's through the sand filters was not significant.
- o Carcinogenic PAH's were removed completely across the sand filters, most probably due to adsorption onto sand particles. Extended test runs and further test work would be required to determine the mechanism for removal of carcinogens across the filters and to determine whether such removals would occur after extended bed contact with high PAH concentrations.
- o At maximum air and gas flow rates, approximately 60-percent oxidation of PAH's was observed. Several specific PAH and heterocycle compounds, however, were virtually unaffected. These results correspond well with results of the bench-scale testing work. Even at maximum gas flow rates, effluent quality did not achieve the MDH goal of 280 ng/l total "other" PAH's.

SUMMARY

Overall conclusions regarding the existing treatment system are summarized as follows:

- o Aeration and chlorination at "standard conditions" achievable at SLP-15 are ineffective for removal of PAH compounds.
- o Aeration and chlorination at the maximum gas flow rates achievable with the existing equipment achieve enhanced PAH removal, but several PAH and other compounds are not effectively removed. Even at maximum gas flow rates, the MDH goal of 280 ng/l total "other" PAH's was not met.
- o Sand filtration does not significantly remove most PAH compounds nor other classes of base neutral compounds.
- o Sand filtration appears to effectively remove carcinogenic PAH's, but extensive test work would be necessary to determine long-term removal rates if

high PAH concentrations were continuously passed through the filters.

- o The high removal of PAH compounds measured in the first round of testing at SLP-15 cannot be explained at this time. Neither bench-scale tests of similar technologies nor repeat tests in the field obtained similar results. It is possible that a) sampling errors, or b) carbon "contamination" in the first round could explain the high observed PAH removals.
- o Observed removal of PAH's during the second round of testing followed bench-scale test observations very closely. Although the carcinogenic PAH standard was met in effluent from the treatment system, the non-carcinogenic PAH concentration exceeded the MDH standard by more than an order of magnitude. This fact supports conclusions drawn from the bench testing program; that is, the unit processes employed at the existing treatment system are not adequate to provide PAH removals for a potable water treatment system.

REFERENCES

The material discussed in this section is presented in detail in Technical Memorandum E.

GLT345/5

Section 5
WATER QUALITY IN NEARBY WATER SUPPLIES
SURFACE WATER BODIES AND STORMWATER RUNOFF

WATER SUPPLIES

At the direction of MPCA, CH2M HILL obtained samples and analyzed potable water supplies in St. Louis Park and in three surrounding communities: Minneapolis, St. Paul, and Plymouth, Minnesota. Two rounds of sampling and analysis were conducted.

On November 16, 1982 grab samples were obtained in the following locations:

- o Influent to St. Paul water treatment system.
- o Effluent from St. Paul water treatment system.
- o Tapwater sample in St. Paul.
- o Influent to Plymouth water treatment system.
- o Effluent from Plymouth water treatment system.
- o Tapwater sample in Plymouth.
- o Influent to Minneapolis water treatment system.
- o Effluent from Minneapolis water treatment system.
- o Tapwater sample in Minneapolis.

Table 5-1 illustrates the analytical results from this sampling round. The results generally indicate low concentrations of PAH and other coal tar derivatives in surrounding water supplies, but two anomalies were noted:

1. The tapwater sample obtained in St. Paul exhibited inordinately high concentrations of phenanthrene and fluoranthene. This sample had far higher total concentrations of PAH's than did other samples.
2. Two of the samples from Minneapolis (treatment plant influent and tapwater) contained a yellow substance which coextracted during sample preparation, resulting in inordinately high detection limits. Sample contamination was suspected.

After consultation with MPCA, a second round of sampling was conducted to further check the results of the first round, and especially to check the high PAH concentrations detected in the St. Paul tapwater sample in the first round.

On January 20, 1983, grab water samples were obtained in the following locations:

- o Effluent from St. Paul water treatment system.
- o Tapwater samples at two locations in St. Paul (both samples in the same neighborhood as the tapwater sample obtained in the first round).

PARAMETER
(All values in ug/l)

Table 5-1
ANALYSIS OF SURROUNDING WATER SUPPLIES
(Samples taken 11/16/82)

Note: All compounds found at less than detection limit have been deleted

| | St. Paul Influent | St. Paul Effluent | St. Paul Tap | Plymouth Influent | Plymouth Effluent | Plymouth Effluent | Plymouth Tap 1 | MPLS Influent | MPLS Effluent | MPLS Tap |
|---|----------------------|----------------------|-----------------|----------------------|----------------------|----------------------|-------------------|------------------|------------------|-------------|
| ANALYSIS BY: | CH2M HILL | CH2M HILL | CH2M HILL | CH2M HILL | CH2M HILL | CH2M HILL | CH2M HILL | CH2M HILL | CH2M HILL | CH2M HILL |
| ANALYTICAL EQUIPMENT: | GC/MS | GC/MS | GC/MS | GC/MS | GC/MS | GC/MS | GC/MS | GC/MS | GC/MS | GC/MS |
| PAH (*INDICATES CARCINOGENIC PAH) | | | | | | | | | | |
| NAPHTHALENE | 16 | 13 | 29 | 7.8 | 5.9 | 5.3 | 9.4 | Note 1 | 9.1 | Note 1 |
| 1-METHYLNAPHTHALENE | | 5.1 | 12 | 1.2 | 1.2 | 1.2 | 6.0 | | 3.8 | |
| 2-METHYLNAPHTHALENE | | 7.4 | 17 | 5.3 | 5.0 | 4.3 | 11 | | 5.4 | |
| ACENAPHTHYLENE | | | 9.0 | | | | | | | |
| ACENAPHTHENE | | | 5.3 | | | | | | | |
| FLUORENE | | | 19 | | | | 9.9 | | | |
| ANTHRACENE | | | 12 | | | | | | | |
| PHENANTHRENE | 5 | 1.0 | 220 | | 1.0 | 1.0 | 37 | | 2.7 | |
| PYRENE | | | 64 | | | | 2.7 | | | |
| FLUORANTHENE | | | 140 | | | | 4.3 | | | |
| PHENYLNAPHTHALENE | | | | | | | | | | |
| 1,2,6,7-TETRAHYDROPYRENE | | | | | | | | | | |
| BENZO(a)ANTHRACENE* | | | 6.0 | | | | | | | |
| 9,10-BENZPHENANTHRENE | | | | | | | | | | |
| CHRYSENE* | | | | | | | | | | |
| BENZO(b,k)FLUORANTHENE* | | | 9.4 | | | | | | | |
| BENZO(a)PYRENE* | | | | | | | | | | |
| BENZO(e)PYRENE | | | | | | | | | | |
| BENZO(j)FLUORANTHENE* | | | | | | | | | | |
| PERYLENE | | | | | | | | | | |
| BENZO(g,h,i)PERYLENE | | | | | | | | | | |
| INDENO(1,2,3-cd)PYRENE* | | | | | | | | | | |
| O-PHENYLENEPYRENE | | | | | | | | | | |
| DIBENZO(a,h)ANTHRACENE* | | | | | | | | | | |
| TOTAL CARCINOGENIC PAH'S | -- | -- | 15.4 | -- | -- | -- | -- | -- | -- | -- |
| TOTAL "OTHER" PAH'S | 21 | 26.5 | 527 | 14.3 | 13.1 | 11.8 | 80.3 | | 21 | |
| NITROGEN HETEROCYCLES | | | | | | | | | | |
| ACRIDINE | | | | | | | | | | |
| CARBAZOLE | | | 28 | | | | 8.4 | | | |
| INDOLE | | | | | | | 5.9 | | | |
| PHENANTHRIDINE | | | | | | | | | | |
| QUINOLINE | | 4.7 | 5.1 | | 1.0 | 1.0 | 1.4 | | 2.4 | |
| SULFUR HETEROCYCLES | | | | | | | | | | |
| BENZO(b)THIOPHENE | | | 1.0 | | | | | | | |
| DIBENZOTHIOPHENE | | | | | | | | | | |
| OXYGEN HETEROCYCLES | | | | | | | | | | |
| DIBENZOFURAN | | | 23 | | | | 7.3 | | | |
| MISCELLANEOUS | | | | | | | | | | |
| BIPHENYL | | | 4.0 | | | | 10 | | | |
| 2,3-DIHYDROINDENE | | | | 3.2 | | | | | | |
| INDENE | | | | | | | | | | |
| 2,3-DIHYDRO-1-INDENE | | 1.4 | 1.4 | | 1.4 | 1.4 | 1.4 | | 1.4 | |
| 1H-INDENE | | | 1.0 | 2.2 | 1.0 | 1.0 | 1.0 | | 2.4 | |
| TOTAL OTHER BASE NEUTRAL COMPOUNDS | | | | | | | | | | |
| AROMATIC AMINES | | | | | | | | | | |
| ANILINE | | | | | | | | | | |
| 1-AMINONAPHTHALENE | | | | | | | | | | |
| 2-AMINOTIPHENYL | | | | | | | | | | |

NOTE 1: Coagulation of a yellow substance caused inordinately high detection limits in these samples.

- o Duplicate samples obtained at the wellhead at St. Louis Park Municipal Well No. 8 (located in the northwest corner of St. Louis Park).
- o Tapwater sample in the northwest corner of St. Louis Park.
- o Effluent from the Minneapolis water treatment plant.
- o Tapwater sample in Minneapolis.

Table 5-2 illustrates the analytical results from the second sampling round. The two tapwater samples obtained in St. Paul showed elevated PAH concentrations, but were well below the MDH guidelines for both carcinogenic and total "other" PAH's. No problems were noted with the second round tapwater sample from Minneapolis, which contained very low concentrations of PAH's and other measured compounds.

The extent of the potable water sampling program was limited, but suggests the following:

- o The existing water supply in St. Louis Park (from wells which have not been shut down by MDH) contains comparable PAH concentrations with treated water supplies in nearby communities.
- o For each community, tapwater samples contained higher PAH concentrations than did water treatment plant effluent (or well water) samples.
- o One tapwater sample in St. Paul (November 1982) had PAH concentrations above the MDH treatment goal of 280 ng/l total "other" PAH. Two confirming tapwater samples (January 1983) had elevated PAH concentrations, but were well below the MDH treatment goal. The confirming samples were obtained in the same neighborhood as the first sample.
- o With the exception of the single tapwater sample from St. Paul, all potable water supply samples obtained from St. Paul, Plymouth, Minneapolis, and St. Louis Park met or exceeded the MDH treatment goals for PAH concentrations.

SURFACE WATERS

At the direction of MPCA, CH2M HILL obtained samples and analyzed surface water bodies in St. Louis Park and surrounding communities.

PAPER: (ALL VALUES IN ug/l)

Table 5-2
ANALYSIS OF SURROUNDING WATER SUPPLIES
(Samples taken 1/20/83)

| | ST. PAUL Effluent | ST. PAUL Tap 1 | ST. PAUL Tap 2 | SLP-8 | SLP-8 | SLP Tap 1 | MPLS Effluent | MPLS Tap 1 |
|---|----------------------|-------------------|-------------------|-----------|-----------|--------------|------------------|---------------|
| ANALYSIS BY: | CH2M HILL | CH2M HILL | CH2M HILL | CH2M HILL | CH2M HILL | CH2M HILL | CH2M HILL | CH2M HILL |
| ANALYTICAL EQUIPMENT | GC/MS | GC/MS | GC/MS | GC/MS | GC/MS | GC/MS | GC/MS | GC/MS |
| PAH (*INDICATES CARCINOGENIC PAH) | | | | | | | | |
| NAPHTHALENE | 13 | 45 | 21 | 7.0 | 7.0 | 5.6 | 8.8 | 20 |
| 1-METHYLNAPHTHALENE | 4.9 | 26 | 6.7 | 2.9 | 2.9 | 2.5 | 2.9 | 4.6 |
| 2-METHYLNAPHTHALENE | 6 | 58 | 12 | 5.9 | 5.9 | 5.2 | 4.7 | 9.3 |
| ACENAPHTHYLENE | | | | | | | | |
| ACENAPHTHENE | | 1.0 | 1.3 | | | 2.6 | | 1.3 |
| FLUORENE | | 1.4 | 6.3 | | | 4.4 | | |
| ANTHRACENE | | | | | | | | |
| PHENANTHRENE | 2.3 | 25 | 95 | 1.0 | 1.0 | 9.3 | 1.0 | 1.0 |
| PYRENE | 1.0 | 3.0 | 12 | | | 1.0 | | |
| FLUORANTHENE | 1.0 | 2.3 | 43 | | | 2.5 | | 1.0 |
| PHENYLNAPHTHALENE | | | | | | | | |
| 1,2,6,7-TETRAHYDROPYRENE | | | | | | | | |
| BENZO(a)ANTHRACENE* | 1.0 | | | | | | | |
| 9,10-BENZPHENANTHRENE | | | | | | | | |
| CHRYSENE* | 2.3 | 1.0 | 3.0 | | | | | |
| BENZO(b,k)FLUORANTHENE* | | | | | | | | |
| BENZO(a)PYRENE* | | | | | | | | |
| BENZO(e)PYRENE* | | | | | | | | |
| BENZO(j)FLUORANTHENE* | | | | | | | | |
| PERYLENE | | | | | | | | |
| BENZO(g,h,i)PERYLENE* | | | | | | | | |
| INDENO(1,2,3-cd)PYRENE* | | | | | | | | |
| O-PHENYLENEPYRENE* | | | | | | | | |
| DIBENZO(a,h)ANTHRACENE* | | | | | | | | |
| TOTAL CARCINOGENIC PAH'S | 3.3 | 1.0 | 3.0 | -- | -- | -- | -- | -- |
| TOTAL "OTHER" PAH'S | 30.2 | 168.7 | 197.3 | 16.8 | 16.8 | 33.1 | 17.4 | 37.2 |
| NITROGEN HETEROCYCLES | | | | | | | | |
| ACRIDINE | | | | | | | | |
| CARBAZOLE | | 1.1 | 5.0 | | | | | |
| INDOLE | | | | | | | | |
| PHENANTHRIDINE | | | | | | | | |
| QUINOLINE | 8.2 | 6.6 | 9.0 | | 1.0 | 1.0 | 2.4 | 3.2 |
| SULFUR HETEROCYCLES | | | | | | | | |
| BENZO(b)THIOPHENE | | 2.0 | 1.0 | | | 1.0 | | 1.0 |
| DIBENZOTHIOPHENE | | | | | | | | |
| OXYGEN HETEROCYCLES | | | | | | | | |
| DIBENZOFURAN | | 2.0 | 6.9 | | | 2.0 | | |
| MISCELLANEOUS | | | | | | | | |
| BIPHENYL | | 2.2 | 1.0 | | | 2.6 | | 1.0 |
| 2,3-DIHYDROINDENE | 3.5 | 19 | 4.2 | 1.4 | 1.4 | 4.9 | 4.1 | 4.1 |
| INDENE | 1.0 | 2.3 | 1.0 | 1.0 | 1.0 | 2.3 | 1.0 | 1.0 |
| TOTAL (OTHER BASE NEUTRAL COMPOUNDS) | | | | | | | | |
| AROMATIC AMINES | | | | | | | | |
| ANILINE | | | | | | | | |
| 1-AMINONAPHTHALENE | | | | | | | | |
| 1-AMINOBIPHENYL | | | | | | | | |

NOTE: All compounds found at less than detection limit have been deleted.

On July 21, 1983, grab samples were obtained in the following locations.

- o Influent to MWCC Pigs Eye wastewater treatment plant.
- o Effluent from MWCC Pigs Eye wastewater treatment Plant (west units).
- o Effluent from MWCC Pigs Eye wastewater treatment plant (east units).
- o Minnehaha Creek - 4 locations
- o Lake Calhoun
- o Lake Harriet
- o Mississippi River - 4 locations

Table 5-3 illustrates the analytical results from this sampling round. Sampling locations are shown in Figure 5-1.

The data is very limited, but suggests the following:

- o PAH removals in excess of 99 percent were measured across the Pigs Eye wastewater treatment plant.
- o PAH concentrations in Minnehaha Creek were below detection limits west of St. Louis Park, but increased as the creek passes through St. Louis Park. Both carcinogenic and total "other" PAH's were found at relatively high concentrations (159 and 211 ng/l, respectively) near the the confluence of Minnehaha Creek and the Mississippi River.
- o Lake Calhoun water contained relatively high concentrations of other PAH's (229 ng/l) but very few carcinogenic PAH's (13.3 ng/l).
- o Lake Harriet water had very low PAH concentrations.
- o Analytical results from samples collected from the Mississippi River are difficult to interpret. At three sampling locations, total PAH concentrations ranged from 0-35 ng/l. The fourth sampling location sampled in duplicate, indicated total PAH concentrations of 230 and 1350 ng/l. The chemist performing the tests believes that particulates in the fourth water samples (UM 847) contributed to the wide spread in analytical results between the two samples.

GLT207/69

Table 5-3
ANALYSIS OF SURFACE WATER SAMPLES
PAGE 1 OF 2

| PARAMETER (ALL VALUES IN ng/l) | Metro Plant Influent | Metro Plant Effluent West | Metro Plant Effluent East | Minnehaha 1 | Minnehaha 2 | Minnehaha 3 | Minnehaha 4 | Lake Calhoun | Lake Harriet |
|--|-------------------------|---------------------------------|---------------------------------|----------------|----------------|----------------|----------------|-----------------|-----------------|
| DATE | 7/21/83 | 7/21/83 | 7/21/83 | 7/21/83 | 7/21/83 | 7/21/83 | 7/21/83 | 7/21/83 | 7/21/83 |
| ANALYSIS BY: | CH2M HILL | CH2M HILL | CH2M HILL | CH2M HILL | CH2M HILL | CH2M HILL | CH2M HILL | CH2M HILL | CH2M HILL |
| ANALYTICAL EQUIPMENT | GC/MS | GC/MS | GC/MS | GC/MS | GC/MS | GC/MS | GC/MS | GC/MS | GC/MS |
| PAH (*INDICATES CARCINOGENIC PAH) | | | | | | | | | |
| NAPHTHALENE | 9,400 | 12 | | | | | | 36 | |
| 1-METHYLNAPHTHALENE | 2,000 | 7 | | | | | | 11 | |
| 2-METHYLNAPHTHALENE | 4,900 | 20 | | | | | | 18 | |
| ACENAPHTHYLENE | | | | | | | | | |
| ACENAPHTHENE | | | | | | 17 | | 110 | |
| FLUORENE | 350 | | | | | 13 | | | |
| ANTHRACENE | | | | | | | | | |
| PHENANTHRENE | 1,000 | 5.8 | | | | 6.4 | 28 | 13 | |
| PYRENE | 350 | 27 | 6.9 | | | 18 | 71 | 27 | 6 |
| FLUORANTHENE | 330 | 7.0 | | | | 26 | 85 | 14 | 11 |
| PHENYLNAPHTHALENE | | | | | | | | | |
| 1,2,6,7-TETRAHYDROPYRENE | | | | | | | | | |
| BENZO(a)ANTHRACENE* | | | | | | | 23 | 6.5 | |
| 9,10-BENZPHENANTHRENE | | | | | | | | | |
| CHRYSENE* | | 8.2 | | | | 7.6 | 32 | 6.8 | |
| BENZO(b,k)FLUORANTHENE* | | | | | | | 51 | | |
| BENZO(a)PYRENE* | | | | | | | 30 | | |
| BENZO(c)PYRENE | | | | | | | | | |
| BENZO(i)FLUORANTHENE* | | | | | | | | | |
| PERYLENE | | | | | | | | | |
| BENZO(a,h,i)PERYLENE | | | | | | | 27 | | |
| INDENO(1,2,3-cd)PYRENE* | | | | | | | 23 | | |
| 0-PHENYLENEPYRENE | | | | | | | | | |
| DIBENZO(a,h)ANTHRACENE* | | | | | | | | | |
| TOTAL CARCINOGENIC PAH'S | - | 8.2 | - | - | - | 7.6 | 159 | 13.3 | - |
| TOTAL "OTHER" PAH'S | 18,330 | 78.8 | 6.9 | - | - | 78.4 | 211 | 229 | 17 |
| NITROGEN HETEROCYCLES | | | | | | | | | |
| ACRIDINE | | | | | | | | | |
| CARBAZOLE | | | | | | | | | |
| INDOLE | | | | | | | | | |
| PHENANTHRIDINE | | | | | | | | | |
| QUINOLINE | | 64 | 19 | | | 6.9 | 9.6 | 8.3 | 6.9 |
| SULFUR HETEROCYCLES | | | | | | | | | |
| BENZO(b)THIOPHENE | | | | | | | | | |
| DIBENZOTHIOPHENE | | | | | | | | | |
| OXYGEN HETEROCYCLES | | | | | | | | | |
| DIBENZOFURAN | | | | | | | | | |
| MISCELLANEOUS | | | | | | | | | |
| BIPHENYL | | | | | | 6.1 | | | |
| 2,3-DIHYDROINDENE | 2,900 | | | | | 19 | | | |
| INDENE | | | | | | | | | |
| AROMATIC AMINES | | | | | | | | | |
| ANILINE | | | | | | | | | |
| 1-AMINONAPHTHALENE | | | | | | | | | |
| 2-AMINOBIPHENYL | | | | | | | | | |

Note: All compounds found at less than detection limit have been deleted.

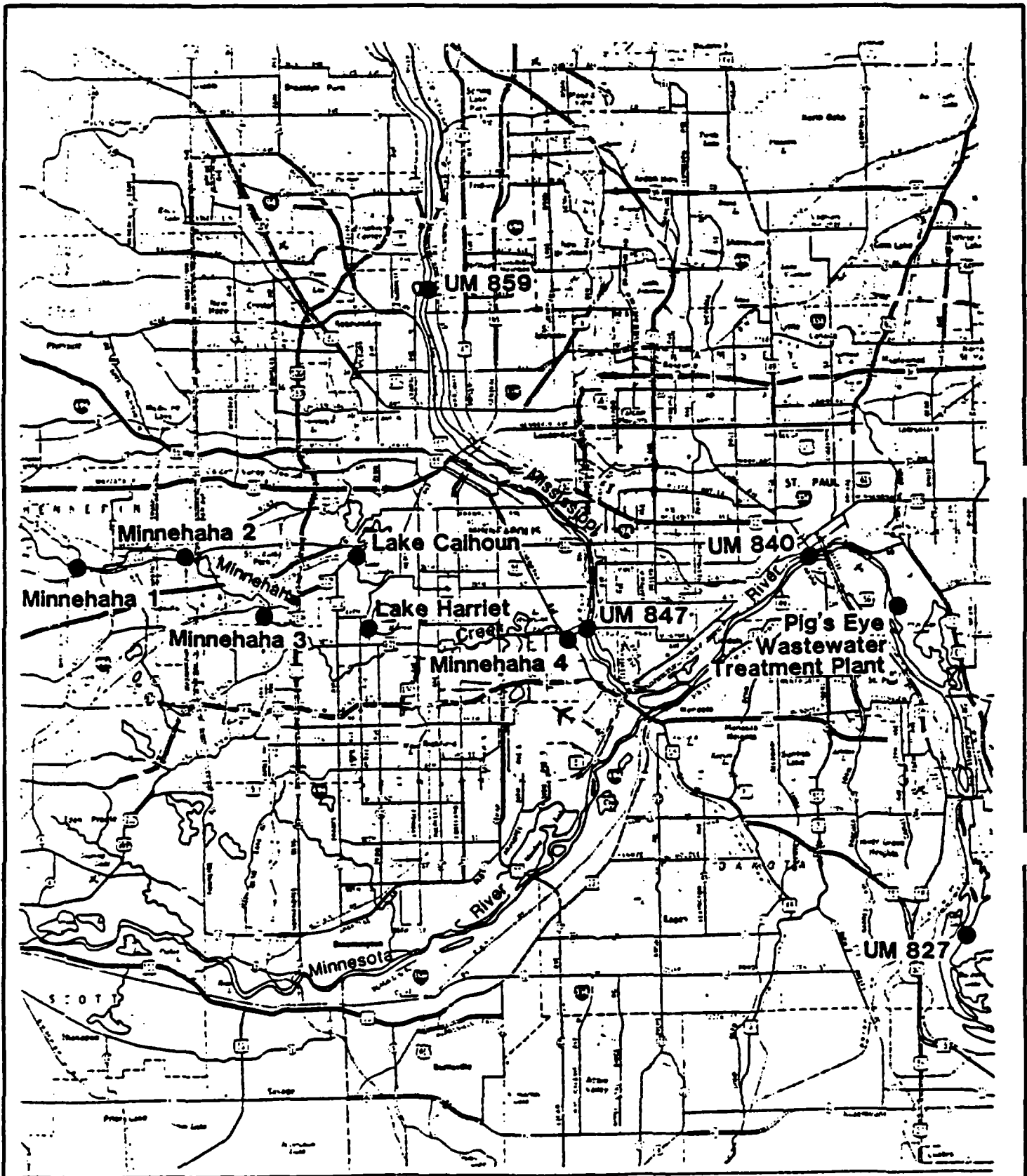

Figure 5-1
 Surface Water Quality
 Sampling Stations

Table 5-3
ANALYSIS OF SURFACE WATER SAMPLES
PAGE 2 OF 2

| PARAMETER (ALL VALUES IN ug/l) | U.M. 827 | U.M. 840 | U.M. 847 | U.M. 847 | U.M. 859 |
|--|-------------|-------------|-------------|-------------|-------------|
| DATE | 7/21/82 | 7/21/83 | 7/21/83 | 7/21/83 | 7/21/83 |
| ANALYSIS BY: | CH2M HILL | CH2M HILL | CH2M HILL | CH2M HILL | CH2M HILL |
| ANALYTICAL EQUIPMENT | GC/MS | GC/MS | GC/MS | GC/MS | GC/MS |
| PAH (*INDICATES CARCINOGENIC PAH) | | | | | |
| NAPHTHALENE | | | | 9.6 | |
| 1-METHYLNAPHTHALENE | | | | | |
| 2-METHYLNAPHTHALENE | | | | | |
| ACENAPHTHYLENE | | | | 20 | |
| ACENAPHTHENE | | | | | |
| FLUORENE | | | | 0.1 | |
| ANTHRACENE | | | | 16 | |
| PHENANTHRENE | | 0.3 | 18 | 95 | |
| PYRENE | | 12 | 48 | 100 | 12 |
| FLUORANTHENE | | 13 | 37 | 220 | 15 |
| PHENYLNAPHTHALENE | | | | | |
| 1,2,6,7-TETRAHYDROPYRENE | | | | | |
| BENZO(a)ANTHRACENE* | | | 16 | 110 | |
| 9,10-BENZOPHENANTHRENE | | | | | |
| CHRYSENE* | | 7.3 | 20 | 130 | 7.5 |
| BENZO(b&k)FLUORANTHENE* | | 9.6 | 31 | 220 | |
| BENZO(a)PYRENE* | | 6.3 | 24 | 140 | |
| BENZO(a)PYRENE | | | | | |
| BENZO(j)FLUORANTHENE* | | | | | |
| PERYLENE | | | | 36 | |
| BENZO(g,h,i)PERYLENE | | | 13 | 81 | |
| INDENO(1,2,3-cd)PYRENE* | | | 11 | 90 | |
| O-PHENYLENEPYRENE | | | | | |
| DIBENZO(a,h)ANTHRACENE* | | | | | |
| TOTAL CARCINOGENIC PAH'S | | 23.2 | 102 | 690 | 7.5 |
| TOTAL "OTHER" PAH'S | | 33.3 | 116 | 643.7 | 27 |
| NITROGEN HETEROCYCLES | | | | | |
| ACRIDINE | | | | | |
| CARBAZOLE | | | | 9.2 | |
| INDOLE | | | | | |
| PHENANTHRIDINE | | | | | |
| QUINOLINE | | 8.3 | 7.0 | | 5.5 |
| SULFUR HETEROCYCLES | | | | | |
| BENZO(b)THIOPHENE | | | | | |
| DIBENZOTHIOPHENE | | | | | |
| OXYGEN HETEROCYCLES | | | | | |
| DIBENZOFURAN | | | | | |
| MISCELLANEOUS | | | | | |
| BIPHENYL | | | | | |
| 2,3-DIHYDROINDENE | | | | | |
| INDENE | | | | | |
| AROMATIC AMINES | | | | | |
| ANILINE | | | | | |
| 1-AMINONAPHTHALENE | | | | | |
| 2-AMINORIPHENYL | | | | | |

Note: All compounds found at less than detection limit have been deleted.

STORMWATER RUNOFF

At the direction of MPCA, CH2M HILL obtained samples and analyzed stormwater runoff at six locations in St. Louis Park and surrounding communities.

Stormwater runoff samples were collected on October 10, 1983. Based on records at the Minneapolis St. Paul weather recording station, the rainfall event on October 10, started at approximately 5:00 a.m. Total rainfall on October 10 was reported by the station to be 1.7 inches. Stormwater samples were collected from 2:30 p.m. to 7:40 p.m. at the six locations shown on Figure 5-2.

Of the six locations sampled, five collected drainage from primarily urban areas. The sixth station (Station No. 5) collected drainage from a local golf course.

Table 5-4 illustrates the analytical results from this sampling round. With the exception of sample number 5, all of the stormwater samples had similar PAH concentrations, with carcinogenic PAH's ranging from 66 to 319 ng/l and total "other" PAH's ranging from 1738 to 2532 ng/l.

GLT207/69

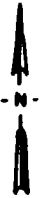
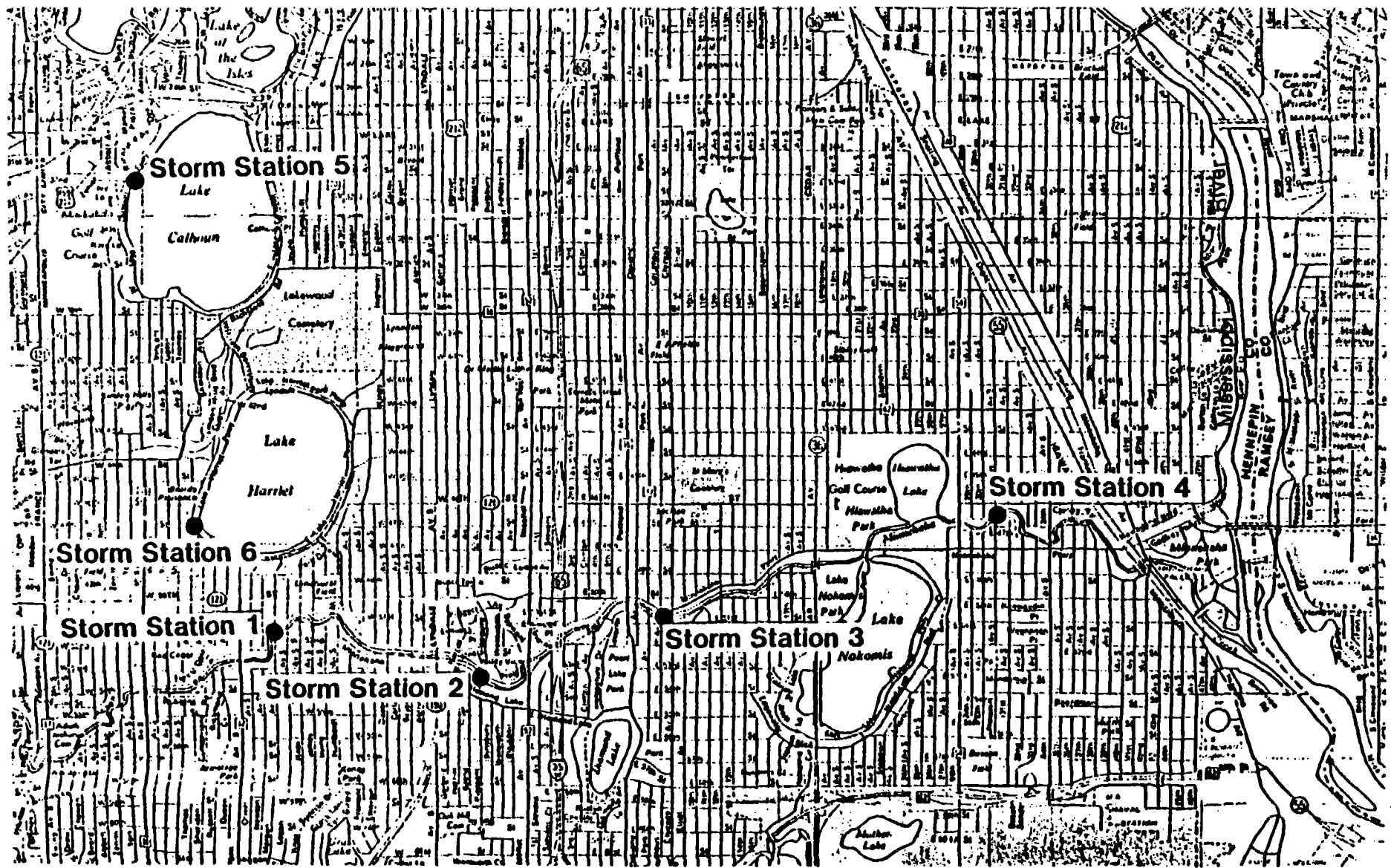

Figure 5-2
Storm Water Quality
Sampling Stations

Table 5-4
ANALYSIS OF STORMWATER RUNOFF SAMPLES

| PARAMETER (ALL VALUES IN ng/l) | Storm | | | | | | | |
|-----------------------------------|-----------|-----------|-----------|-----------|----------------|-----------|-----------|--|
| | 1 | 2 | 3 | 4 | 4 Duplicate | 5 | 6 | |
| DATE: | 10/10/83 | 10/10/83 | 10/10/83 | 10/10/83 | 10/10/83 | 10/10/83 | 10/10/83 | |
| ANALYSIS BY: | CH2H HILL | CH2H HILL | CH2H HILL | CH2H HILL | CH2H HILL | CH2H HILL | CH2H HILL | |
| ANALYTICAL EQUIPMENT: | GC/MS | GC/MS | GC/MS | GC/MS | GC/MS | GC/MS | GC/MS | |
| PAH'S | | | | | | | | |
| NAPHTHALENE | 320 | 250 | 380 | 370 | 420 | 150 | 360 | |
| 1-METHYLNAPHTHALENE | 190 | 260 | 280 | 460 | 580 | 160 | 380 | |
| 2-METHYLNAPHTHALENE | 300 | 540 | 570 | 800 | 1,000 | 260 | 750 | |
| ACENAPHTHYLENE | | | | | | | | |
| ACENAPHTHENE | 54 | 67 | | | | | 60 | |
| FLUORENE | 91 | 61 | 60 | 35 | | | 76 | |
| ANTHRACENE | 67 | 30 | | 25 | 32 | | 66 | |
| PHENANTHRENE | 240 | 220 | 230 | 170 | 220 | 85 | 300 | |
| PYRENE | 190 | 130 | 110 | 108 | 120 | 52 | 120 | |
| FLUORANTHENE | 290 | 170 | 170 | 150 | 160 | 56 | 160 | |
| PHENYLNAPHTHALENE | | | | | | | | |
| 1,2,6,7-TETRAHYDROPYRENE | | | | | | | | |
| BENZO(a)ANTHRACENE* | 59 | 36 | 28 | 36 | 38 | | | |
| 9,10-BENZPHENANTHRENE | | | | | | | | |
| CHRYSENE* | 130 | 66 | 52 | 63 | 86 | | 66 | |
| BENZO(b,k)FLUORANTHENE* | 130 | 62 | | | | | | |
| BENZO(e)PYRENE* | | | | | | | | |
| BENZO(a)PYRENE | | | | | | | | |
| BENZO(j)FLUORANTHENE* | | | | | | | | |
| PERYLENE | | | | | | | | |
| BENZO(g,h,i)PERYLENE | | | | | | | | |
| INDENO(1,2,3-cd)PYRENE* | | | | | | | | |
| O-PHENYLENEPYRENE | | | | | | | | |
| DIBENZO(a,h)ANTHRACENE* | | | | | | | | |
| TOTAL CARCINOGENIC PAH'S | 319 | 162 | 80 | 97 | 124 | - | 66 | |
| TOTAL "OTHER" PAH'S | 1,842 | 1,738 | 1,780 | 2,118 | 2,532 | 741 | 2,210 | |
| NITROGEN HETEROCYCLES | | | | | | | | |
| ACRIDINE | | | | | | | | |
| CARBAZOLE | 400 | 140 | 190 | 100 | 120 | 32 | 260 | |
| INDOLE | 110 | 110 | 130 | | 67 | | | |
| PHENANTHRIDINE | | | | | | | | |
| QUINOLINE | 190 | 110 | 120 | 100 | 99 | 61 | 130 | |
| SULFUR HETEROCYCLES | | | | | | | | |
| BENZO(b)THIOPHENE | | | | | | | | |
| DIBENZOTHIOPHENE | | | | | | | | |
| OXYGEN HETEROCYCLES | | | | | | | | |
| DIBENZOFURAN | | | | | | | | |
| MISCELLANEOUS | | | | | | | | |
| BIPHENYL | 32 | 56 | | | 33 | | | |
| 2,3-DIHYDROINDENE | 72 | | 52 | 66 | 66 | 39 | 65 | |
| INDENE | 34 | 69 | 34 | 28 | 34 | | | |
| AROMATIC AMINES | | | | | | | | |
| ANILINE | | | | | | | | |
| 1-AMINONAPHTHALENE | | | | | | | | |
| 2-AMINOBIPHENYL | | | | | | | | |

Note: All compounds found at less than detection limit have been deleted.

Section 6
BENCH-SCALE TESTING PROGRAM

INTRODUCTION

This section describes a series of bench-scale tests performed on water obtained from SLP-15 (PAH concentration in untreated water of roughly 7,000 ng/l). The ultimate purpose of the bench-scale test program was to identify a cost-effective water treatment technology to achieve acceptable removals of PAH and other coal tar derivative compounds. Bench-scale tests were performed as a first step toward developing: 1) a pilot-scale test program and 2) design criteria for a full-scale treatment system.

BENCH TESTING RESULTS

Prior to testing, technologies had been identified in a literature search and technology assessment (see Section 2). A two-round test program was designed. The first round was conducted under very conservative test conditions (high dosage, long retention, etc.) and was designed to quickly determine which technologies could achieve compliance with the Minnesota Department of Health treatment goals for PAH compounds in potable water, as summarized below:

| <u>PAH Category</u> | <u>MDH Treatment Goal</u> |
|---------------------------|---------------------------|
| Carcinogenic PAH's, total | 28 ng/l |
| All other PAH's, total | 280 ng/l |

Round two testing was conducted only on technologies which met the treatment goals in the first round tests and was designed to identify required dosages, loading rates and detention times in greater detail.

Granular Activated Carbon (GAC)

Activated carbon treatment worked well during round one isotherm testing. Five carbons were tested and all of the carbons removed total PAH's to below 70 ng/l at a 25 mg/l dose. Even though adsorptive capacity of the five carbons was about the same, the Calgon, Westvaco and ICI carbons produced the lowest total PAH concentrations in the effluent.

Calgon and Westvaco granular activated carbon were selected for column testing in round two. Carbon column tests produced effluents with total PAH concentration less than 30 ng/l after 100 bed volumes of water had passed through the column.

Macroreticular Resins

Isotherm tests with three macroreticular resins yielded very poor results in round one with virtually no removal of PAH's.

Oxidation

Ozone-UV and peroxide-UV were the only two oxidation technologies that met treatment goals in the screening round. Ozone-UV at 10 mg/l and 1-hour contact time with UV produced the best quality effluent with total PAH concentrations of less than 10 ng/l. Round two testing showed that ozone-UV produced acceptable results at 1 mg/l and 20-minute contact time. Peroxide-UV met treatment criteria at 2 mg/l and 20-minute contact time, but only by a small margin. Peroxide-UV at 5 mg/l and 60-minute contact time achieved very good results. Both technologies required UV to achieve acceptable results at the retention times tested.

Detailed analysis of GC/MS chromatograms detected numerous oxidation byproducts in effluent from one of the ozone oxidation tests, but virtually no oxidation byproducts were found in effluent from one of the ozone-UV tests. This further confirms the need for UV in combination with ozone or hydrogen peroxide since the health effects of by-products, and especially chlorinated by-products are not well known.

Chlorine and ClO₂ removed only selected compounds, leaving total PAH concentration well above the 280 ng/l level. Various combinations of aeration/chlorination/flocculation/filtration also provided effluents with unacceptably high concentrations of PAH's.

Membrane Technologies

Neither RO nor ultrafiltration was tested, since round one tests demonstrated the viability of three conventional technologies.

COMPARISON OF VIABLE TECHNOLOGIES

As noted, three technologies achieved good PAH removals in the first round of testing and were tested further in the second round. These were:

- o Granular activated carbon adsorption (GAC)
- o Ozone/UV oxidation
- o Hydrogen peroxide/UV oxidation

A conceptual design of a full-scale system was developed for each of these technologies. The following information was developed for each technology:

- o System design criteria, based on the bench-scale test program.
- o System operating philosophy.
- o A flow diagram to illustrate major system components and size.
- o Order-of-Magnitude comparative capital and annual operating and maintenance cost estimates. The estimates prepared at this point in the project were limited to equipment within the treatment system "battery limits" and were intended only to provide an estimate of relative costs among the three systems.
- o The advantages and disadvantages of each system.

It was assumed that the water from SLP-15 would be treated for PAH removal at the wellhead (i.e., upstream from the existing iron removal system). Each technology was evaluated assuming a flow rate of 800 gpm. (Based on information available from Hickok's 1981 study.) Later pump testing at SLP-15 indicated that SLP-15 is capable of delivering a higher flow rate (see Section 9).

Granular Activated Carbon Adsorption

System Design Criteria

Isotherm tests indicated that, at total PAH concentrations of around 7,000 ng/l, GAC has an adsorption capacity of approximately 3,000 ng PAH/mg carbon. Although isotherm results cannot be accurately translated into ultimate adsorption capacity, it was assumed that GAC will have an ultimate adsorption capacity of 2,000 ng/mg carbon.

Bench-scale column studies were conducted at 4 gpm/ft² surface loading rate, with a 35-inch bed depth. These loadings produced effluent PAH concentrations in the range of 25-30 ng/l. For the purpose of this cost comparison, the system was sized at 4 gpm/ft² and with a 30-minute nominal contact time (empty bed basis). The "design" contact time was based on standard design criteria and on vendor recommendations.

Design criteria for the conceptual GAC treatment system is summarized as follows:

| <u>Criteria</u> | <u>Design Value</u> |
|------------------------------------|---------------------|
| Flow Rate, gpm | 800 |
| Carbon Columns | |
| Number | 2 |
| Bed Volume (empty), gal per column | 12,000 |
| Carbon Capacity (per bed), lb | 40,000 |
| Carbon Capacity (total), lb | 80,000 |
| Loading Rate, gpm/ft ² | 4 |
| Load/Unload/Backwash Tank | |
| Number | 1 |
| Volume | 20,000 gal |

Operating Philosophy

Two carbon columns would be used. These columns would be piped in series so that either column could be used as the lead column. When breakthrough occurs, the lead column would be taken out of service and the carbon would be replaced. This column would then become the polishing column. The transfer tank would be used to hold spent carbon while new carbon is placed in the column. The spent carbon would then be transferred to the carbon truck. During normal operation this transfer tank would be used to store backwash supply water. For this system it was assumed that dirty backwash would be disposed of in the existing sand filter dirty backwash basin.

System Flow Sheet

Figure 6-1 illustrates a conceptual flow sheet for the GAC treatment system.

Cost Estimates

The estimated capital cost of this alternative was \$691,500. The estimated annual O & M cost was \$72,700.

Advantages and Disadvantages

The following were considered advantages of GAC adsorption relative to potential application at St. Louis Park:

- o GAC is a state-of-the-art technology for removal of organics from drinking water supplies.
- o A GAC system has few moving mechanical parts. Maintenance of the system is very simple. The system would not be as subject to mechanical failure as other systems under consideration.

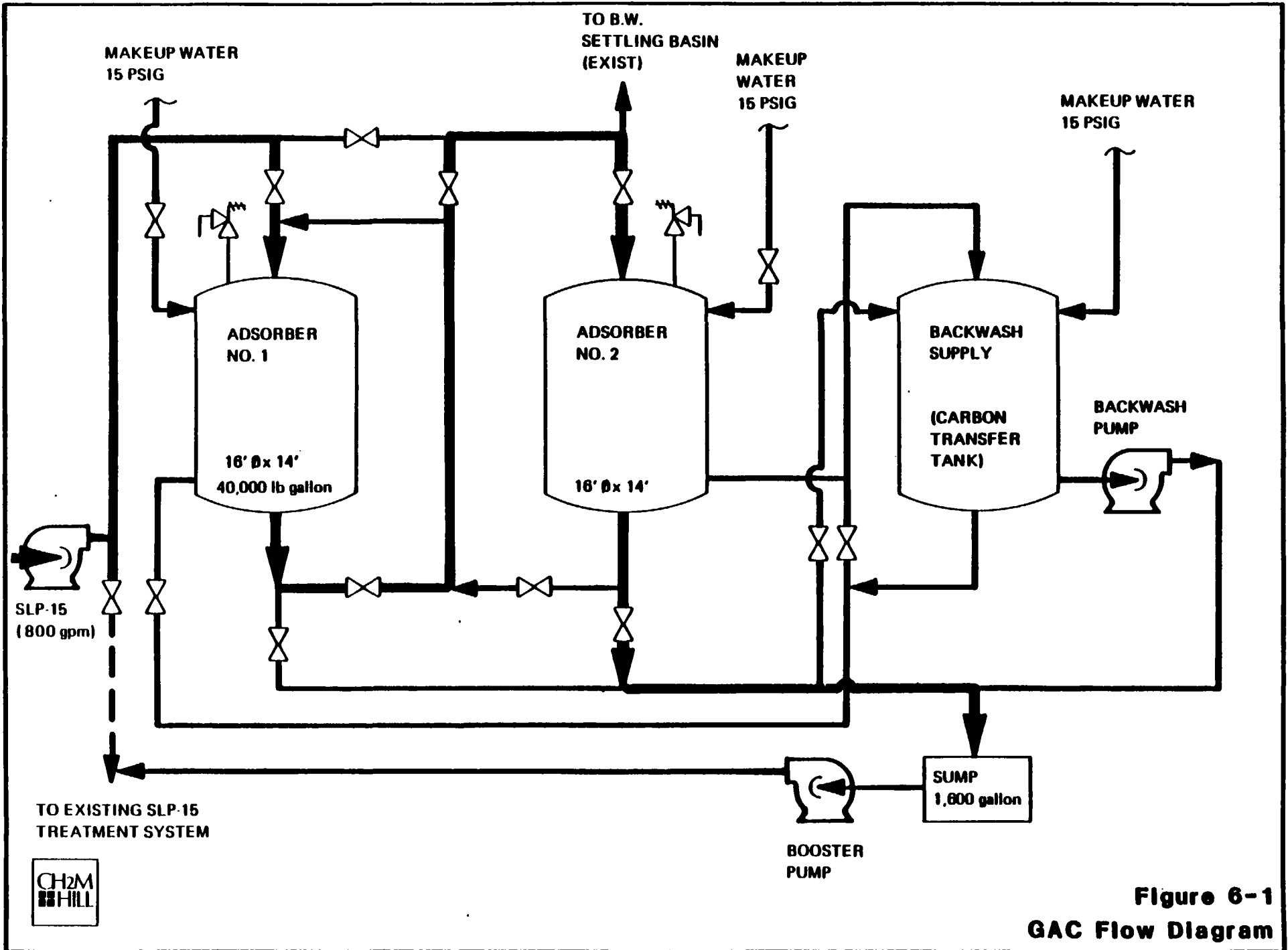

Figure 6-1
GAC Flow Diagram



- o Assuming proper operation and timely replacement of spent carbon, a GAC system should have tremendous reserve capacity to remove any "slug" loadings of PAH's which could be encountered. No operator adjustments would be necessary to accommodate such "slug" loads.
- o In comparison to oxidation technologies, GAC has no potential for generation of oxidation byproducts.
- o Since GAC treatment does not oxidize iron no additional iron removal facilities would be required at wells that currently do not remove iron.

The following were considered disadvantages of GAC adsorption relative to potential application at St. Louis Park:

- o Biological growths in the GAC columns could potentially increase chlorine requirements in the existing treatment system (pre-chlorination before the GAC columns would result in precipitation of iron within the column. The operating plan would, therefore, be to slug dose chlorine for biological growth control only at times backwashing is conducted).
- o If excessive sand concentrations are encountered in raw well water, it could become necessary to a) isolate one bank of the existing sand filters and replumb the system to treat effluent from the filter rather than raw well water or b) install a desander at the well head.
- o GAC produces spent carbon which must be regenerated or disposed.

Ozone/UV Oxidation

System Design Criteria

Bench-scale tests indicated that 1 mg/l ozone at 20-minute retention time with UV gave an effluent of 60 ng/l total PAH. Based on interpretation of bench-scale data, it appeared that the desired effluent quality could be achieved with a 10- to 12-minute retention time. For purposes of this cost comparison, a 10-minute retention time was assumed, at an ozone dose of 1 mg/l. Design criteria for the conceptual ozone UV system is summarized as follows:

| <u>Criteria</u> | <u>Design Value</u> |
|------------------|---------------------|
| Flow Rate, gpm | 800 |
| UV Reactors | |
| Number | 1 |
| Dimensions, ft | 30 x 7½ x 6 |
| Volume, gal | 8,000 |
| No. of Lamps | 900 |
| Watts per Lamp | 65 |
| Ozone Generator | |
| Feed Source | Air |
| Capacity, lb/day | 14 |
| Recycle Pump | |
| Flow, gpm | 100 |

Operating Philosophy

The ozone UV system (based on quotation from Westgate Research Corp.) would consist of a large basin with quartz tubes placed on 6-inch centers. UV bulbs would be placed in the quartz tubes. Ozone generated from air would be fed to the reactor through a header system. The system would be closed and would operate at about 1 psig pressure.

The dose of ozone would be set by controlling air flow and ozone concentration in the feed. The dose would be set and maintained at about 3 grams/minute ozone. The ozone generator would have 50-percent excess capacity so it would be capable of delivering a 1.5 mg/l dose to the 800 gpm waste stream.

System Flow Sheet

Figure 6-2 shows a conceptual flow sheet for the ozone UV system.

Cost Estimates

The estimated capital cost of this alternative was \$659,000. The estimated annual O&M cost was \$183,000.

Advantages and Disadvantages

The following were considered advantages of O₃/UV oxidation relative to potential application at St. Louis Park:

- o This system has the lowest space requirements of any of the treatment systems under consideration.

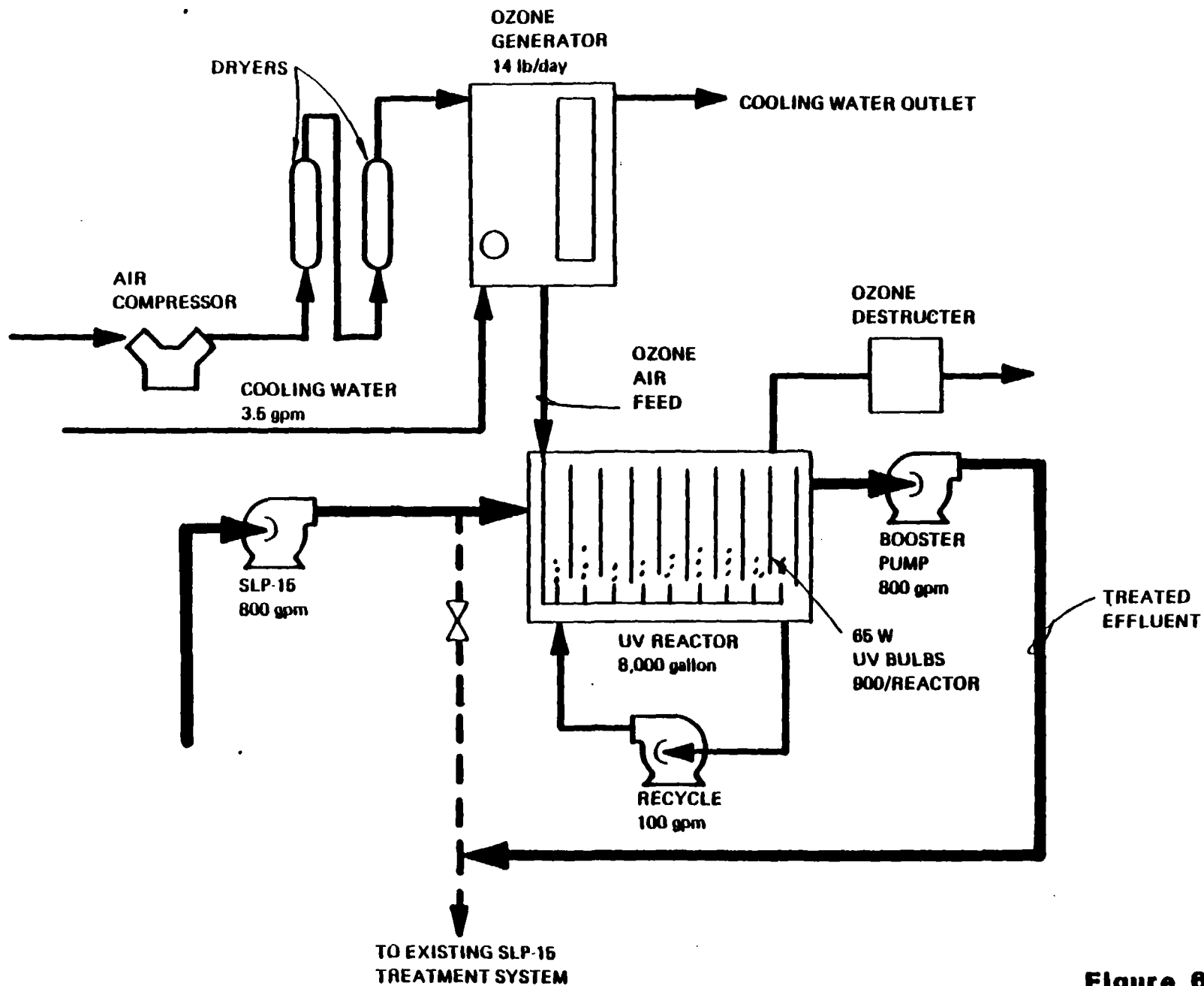

Figure 6-2
Ozone-UV Flow Diagram

- o This technology does not generate any spent waste products requiring offsite treatment (such as spent GAC).
- o Ozone oxidation of Fe^{+2} to Fe^{+3} could reduce chlorine requirements at the existing treatment system.

The following were considered disadvantages of O_3 /UV oxidation relative to potential application at St. Louis Park:

- o Some UV installations treating water with high iron concentrations have experienced chemical fouling of the UV lamps. If this were to occur at St. Louis Park, it could become necessary to isolate one bank of the existing sand filters and replumb the system to treat effluent from the filter rather than raw water.
- o Both the O_3 generator and the UV lamps would require a good deal of maintenance to ensure consistently high performance of the treatment system.
- o It is possible that "slug" loads or short term increases in influent concentrations of PAH's could pass through the treatment system unless operators adjust the dosage of O_3 and/or retention time in the system. Given the turnaround time required for PAH analysis, it would not be possible for operators to deal effectively with short term perturbations.
- o It is possible that future system modifications would be required if influent water quality changes (i.e., if O_3 demand rises with increasing PAH concentrations, a conservatively sized O_3 generator would not be capable of treating worse-than-design water quality).
- o Although both O_3 and UV are state-of-the-art technologies, their use in treating drinking water supplies is somewhat limited.
- o If all or part of the UV lamps fail/foul, bench-scale tests indicate that oxidation byproducts may be left in the water.
- o Since ozone would oxidize ferrous iron to ferric, iron removal facilities would be required at wells that currently do not remove iron. This would approximately double the estimated cost of the system, if required at other wells.

Hydrogen Peroxide/UV Oxidation

System Design Criteria

Bench-scale tests indicated that 2 mg/l H₂O₂ with 20 minutes UV barely met treatment standards. For added safety a 5 mg/l H₂O₂ dose with 20 minutes UV was used for the "design" case.

Conceptual design criteria for the peroxide UV system is as follows:

| <u>Criteria</u> | <u>Design Value</u> |
|------------------------|---------------------|
| Flow rate, gpm | 800 |
| UV Reactors | |
| Number | 2 |
| Dimensions each, ft | 30 x 7½ x 6 |
| Volume each, gal | 8,000 |
| No. of Lamps, ea. unit | 900 |
| Watts per lamp | 65 |
| Peroxide Feed | |
| Tank volume, gal | 1,200 |
| Pump, gph | 0.5 |
| Feed concentration | 50% |
| Recycle Pump | |
| Number | 2 |
| Flow each, gpm | 100 |

Operating Philosophy

The peroxide UV system will be similar to the ozone system except that two reactors would be required to give the 20 minute retention time. Fifty percent peroxide would be fed from a storage tank using a positive displacement chemical metering pump. The peroxide would be added through a static mixer prior to the UV reactors. Recycle pumps would be used to increase turbulence to minimize fouling of the tubes. Peroxide dose could easily be changed by adjusting stroke and/or frequency on the feed pump.

System Flow Sheet

Figure 6-3 illustrates a conceptual flow sheet for a peroxide UV treatment system.

Cost Estimates

The estimated capital cost of this alternative was \$1,158,000. The estimated annual O&M cost was \$281,500.

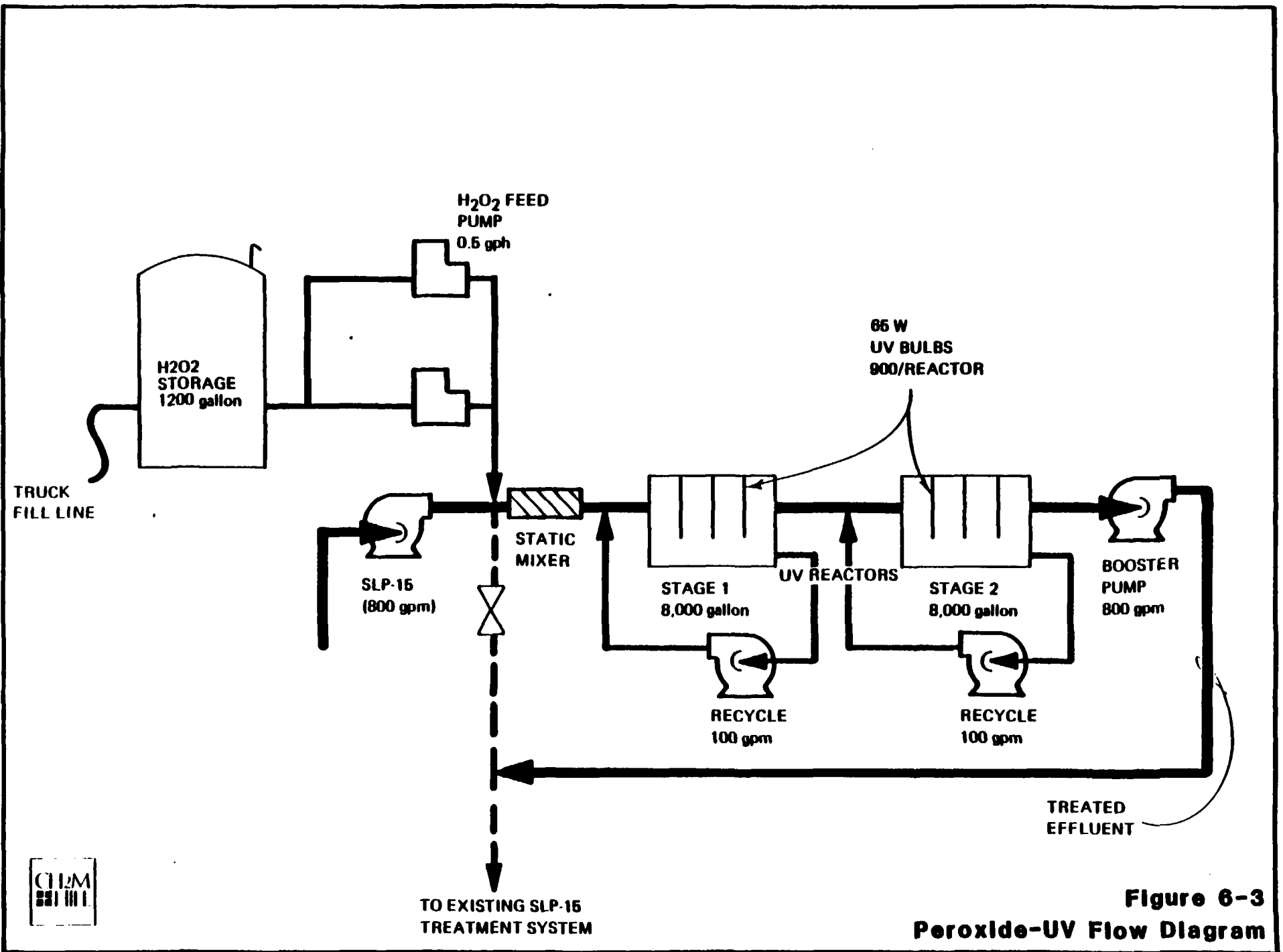

Figure 6-3
Peroxide-UV Flow Diagram



Advantages and Disadvantages

The following were considered advantages of H_2O_2 /UV oxidation relative to potential application at St. Louis Park:

- o This system has moderate space requirements.
- o This technology does not generate any spent waste products required offsite treatment (such as spent GAC).
- o Peroxide oxidation of Fe^{+2} to Fe^{+3} could reduce chlorine requirements at the existing treatment system.
- o Adjustment of oxidant feed rate to accommodate changed water conditions would be very easy, requiring only a pump modification.

The following were considered disadvantages of the H_2O_2 /UV oxidation relative to potential application at St. Louis Park:

- o Iron fouling of UV lamps could occur (see previous discussion).
- o UV lamps will require a good deal of maintenance (see previous discussion).
- o "Slug" loads could pass through the system (see previous discussion).
- o Application of this combination of technologies for drinking water treatment is untried.
- o Although detailed analysis of the GC/MS scan was not conducted, it is likely that H_2O_2 /UV leaves more oxidation byproducts in the final effluent. (The oxidation potential is less than O_3 /UV.)
- o Additional iron removal facilities may be required (see ozone UV discussion).

Cost Comparison

Annualized costs of the three conceptual treatment systems are summarized as follows:

| <u>System</u> | <u>Estimated Capital Cost</u> | <u>Estimated Annual O&M</u> | <u>Annual Cost *</u> |
|-----------------------------------|-------------------------------|---------------------------------|----------------------|
| GAC | \$ 691,500 | \$ 72,700 | \$139,900 |
| O ₃ /UV | 659,000 | 183,800 | 247,800 |
| H ₂ O ₂ /UV | 1,158,000 | 281,500 | 394,000 |

*Annual cost includes estimated annual O&M cost plus amortized capital cost over 20 years with zero assumed salvage value.

SELECTION OF TECHNOLOGY FOR PILOT TESTING

It was recognized that estimated total capital and O&M costs for each of the three systems under consideration could change based on additional data gathered in pilot-scale test work. Selection of a single technology for pilot testing, therefore, needed to be based on a clear advantage of that technology over others under consideration.

Technological Considerations

From a technology standpoint, GAC was clearly the most proven technology under consideration. It has superior flexibility for both short- and long-term fluctuations in water quality, requires less effluent quality monitoring, and is a proven, state-of-the-art technology for treatment of drinking water.

Both oxidation technologies would require more extensive pilot-scale test work than GAC to fully define optimum design criteria. Variables which would have to be tested include:

- o Oxidant dosage
- o Retention time
- o UV time requirements
- o Spacing requirements for UV lamps
- o UV lamp intensity requirements
- o Impact of iron fouling
- o Effect of influent concentration on design requirements

The extensive test work required for oxidation technologies would a) increase time requirements for the pilot work and b) increase pilot testing costs.

Cost Considerations

The conceptual cost comparisons indicated that, on an annual cost basis, GAC was the most cost-effective technology under consideration.

Bench-scale tests of H₂O₂/UV provided a good estimate of required oxidant dosage and retention time requirements. This technology is clearly the most costly of the three.

It is possible that O₃/UV could provide adequate treatment with even less UV retention time than was illustrated in the conceptual design. Even if the retention time could be cut in half, however, the annual cost of the system would be higher than the carbon system estimated. Furthermore, if O₃/UV systems were installed at wells without existing iron removal systems, required capital costs would be increased further.

On the basis of these considerations, GAC was selected for pilot-scale testing at SLP-15.

REFERENCES

The material discussed in this section is presented in detail in Technical Memoranda H and I.

GLT233/9

Section 7
PILOT-SCALE TESTING PROGRAM

A pilot-scale GAC test program was conducted at the well house of St. Louis Park Municipal Well SLP-15 to measure removal of PAH compounds and other coal tar derivatives. For comparative purposes, two pilot trains were used, one with Calgon Filtrasorb 300 and one with Westvaco Nuchar WV-G. The selection of granular activated carbon for pilot-scale test work was based on the results of bench-scale test work and on cost comparisons with other viable technologies (see Section 6). Pilot-scale GAC columns were rented from Westvaco and Calgon Corporations. Each system was equipped with four 4-inch diameter glass columns designed for 36-inch carbon depths.

The objective of the pilot testing program was to produce sufficient operating and performance data for development of design criteria for a full-scale GAC treatment system at SLP-15. The primary goal of the full-scale system would be to reduce PAH's to MDH standards to provide an additional drinking water supply for the city of St. Louis Park.

PILOT PLANT OPERATIONS

CH2M HILL and/or Barr Engineering Company staff monitored pilot plant operation during the day and were responsible for daily testing routines. City of St. Louis Park staff were responsible for monitoring operations in the evening and at night. Inspections were performed three times during the day shift and twice during the remaining shifts. During each inspection, the feed rate to each column train was noted and adjusted to 0.44 gpm (5 gpm/ft²) if necessary. Flow totalizer readings were noted and all pressure indicators were read and recorded.

Once per day, temperature, dissolved oxygen, and conductivity were measured at the inlet and outlet of each column train. Dissolved oxygen samples were drawn in a manner to avoid aeration of the sample. A modified Winkler analysis (full bottle method) was used for DO determination. A YSI conductivity meter was used for conductivity and temperature measurements.

Daily log sheets were prepared documenting all measurements, records and adjustments made during the inspections. The original data sheets are in CH2M HILL's project files.

PILOT TESTING RESULTS

Westvaco Nuchar WV-G

Breakthrough occurred in the Westvaco lead column by the sixth day of operation. Samples drawn on subsequent sampling dates showed increasing concentrations of PAH's, including bleed through of some carcinogenic PAH's. After backwashing (day 21 of operation), PAH concentrations in effluent from the first column dropped to below the 280 ng/l limit, but were still higher than in effluent from the lead Calgon column.

The lead Westvaco column was taken out of service on day 25 of operation and column 2 was placed in the lead position. This step was taken to determine whether the second column would break through in the same period of operation as column 1. PAH's in the effluent from column 2 rose to 200 ng/l as soon as the second column was placed in the lead position.

The data indicate that there was probably an anomaly in the physical setup of column 1 of the Westvaco train, but the performance of the Westvaco carbon was still inferior to that of the Calgon carbon.

Calgon Filtrasorb 300

The Calgon column train displayed consistently low effluent PAH concentrations and no bleed through of carcinogenic compounds.

PAH concentrations in the effluent from columns 2, 3, and 4 remained approximately constant throughout the entire testing period. Naphthalene, 1-methylnaphthalene, 2-methylnaphthalene, and phenanthrene reached apparent equilibrium concentrations in the first column and no further removal occurred in columns 2, 3, and 4.

At the conclusion of the scheduled 30-day test run, PAH concentrations in the effluent from the lead Calgon column were still very low (less than 20 ng/l). The test run of the Calgon system was extended and samples of the effluents from the first two columns were taken on a less frequent basis.

After 42 days of operation, breakthrough of the first column had still not occurred. Although several additional PAH's started to appear in effluent from the column, total PAH concentration was only 21.5 ng/l, with no apparent breakthrough.

The pilot test was terminated after 42 days of operation. Further extension of the testing period would have been desirable to accurately define carbon life, but was not critical to definition of design criteria for a full-scale system.

DESIGN CRITERIA FOR FULL-SCALE TREATMENT SYSTEM

This section discusses the design criteria for a full-scale treatment system. For the details of the conceptual design developed from these criteria see Section 9, "Selection of Water Supply Alternative for St. Louis Park," subsection "Conceptual Design of Selected Alternative."

Initial Carbon Selection for Full-Scale System

Based on the effluent characteristics of the two pilot-scale column trains and the uncertainty regarding the cause for breakthrough in the Westvaco column train, Calgon Filtrasorb 300 is the recommended carbon for initial installation in a full-scale GAC treatment.

Other brands of carbon may be as effective and cost competitive, however. If a full-scale system is installed, it is recommended that small-scale "minicolumns" be installed for testing of other carbons. Other vendors wishing to compete for carbon replacement could provide samples of their carbon in the minicolumns and the city could measure breakthrough characteristics for PAH's. Using this concept, the city of St. Louis Park can develop competitive bidders for long-term carbon replacement.

Carbon Contact Time and Column Arrangement

Data obtained in the pilot-scale tests indicated excellent PAH removals at contact times of less than 5 minutes (empty bed basis).

During conceptual design, both two and three-column systems were evaluated. Because Calgon delivers carbon in standard 20,000 pound truckload quantities it was necessary to evaluate reactor sizes in multiples of 20,000 pound capacity (to reduce carbon replacement costs). After some consideration, a three-column arrangement was selected. When the carbon in the lead position is exhausted, the second column will be placed in the lead position and new carbon will be placed in the "exhausted" column. During the carbon replacement period, the second and third columns would be operated by themselves. Each of the three columns would contain 20,000 lb carbon. The three columns would provide a total contact time of 12.9 minutes. Although pilot-scale data indicate that a slightly lower contact time would probably be sufficient, some conservatism is appropriate to ensure finished water quality during periods when one column is out of service for carbon replacement.

The recommended three-column arrangement further allows greater utilization of carbon adsorption capacity. With two "fresh" columns downstream, the lead column can be run past the

"breakthrough" point and can possibly be run to "exhaustion" before carbon replacement.

Carbon Regeneration

The projected low annual rate of carbon consumption makes on-site regeneration uneconomical. This would dictate that spent carbon be hauled off-site for regeneration at remote facilities. Telephone quotations received from carbon vendors indicated that the cost of regenerated carbon (including two round trips to the site to a) remove spent carbon and the b) return the regenerated carbon) would be approximately the same as replacement with virgin carbon and disposal of the spent carbon. If the offsite regeneration option were selected, there is some concern that carbon shipments could be mixed up and that regenerated carbon shipments could be mixed up and that regenerated carbon returned to St. Louis Park could potentially be from other types of facilities (e.g. tertiary wastewater treatment systems). After reviewing these facts, the MDH ruled that regenerated carbon should not be used for the system at St. Louis Park. When carbon is exhausted, it will be replaced with virgin carbon.

Carbon Capacity

Since the pilot-scale test was terminated before exhaustion of the carbon in Calgon column 1, there is some uncertainty regarding the ultimate adsorption capacity of Calgon Filtrasorb 300. Available data, however, permit reasonable estimates of a minimum anticipated carbon capacity of 0.0004 lb PAH/lb carbon. The actual carbon capacity will probably be higher than this projected minimum. Maximum probable carbon capacity (based on isotherm tests in the bench-scale program) is about 0.002 lb PAH/lb carbon.

Design Flow Rate and Raw Water Quality

A recent pump test indicated that the existing well pump at SLP-15 can provide a flow rate of 1,200 gpm at 30 psig discharge pressure at the wellhead. For the purposes of sizing a full-scale treatment system at SLP-15, a flow rate of 1,200 gpm was assumed.

An analysis of historical measurements of PAH concentrations at SLP-15 indicates that about 7,000 ng/l total PAH's can be expected. Concentrations measured during the pilot-scale program were slightly higher, but this is probably because of the very small pumping rate of the pump used for the pilot plant. For the purpose of conceptual design, a total PAH concentration of 7,000 ng/l was assumed.

Annual Carbon Consumption

At a flow rate of 1,200 gpm and raw water total PAH concentration of 7,000 ng/l, approximately 0.1 lb PAH's will be removed each day the system is in operation. Assuming 24 hours/day, 365 days/year operation, approximately 36.8 lb PAH's will be removed by the system each year.

The range of expected carbon capacity, as described earlier, is 0.002 to 0.0004 lb PAH's/lb carbon.

Annual carbon consumption is, therefore, expected to be in the range of 18,400 to 92,000 lb carbon/year.

REFERENCES

The material discussed in this section is presented in detail in Technical Memoranda J and K.

GLT233/6

4/15/85 Don Gallo Bob Burke John -

4 filter banks - each well goes to its own.

Calgon - single bank (parallel) - only use carbon to breakthrough,
not exhaustion

Main Issues

- 1) Arrangement of columns
- 2) Position relative to sand filters

Other Issues

- 1) Need for booster pumps - head loss thru system.

Alternative bid process

Equipment list first = speed up process, Actual
design to follow

If need Booster pumps - require 6 week ordering time

Weekly reports

Other concerns - Park i. public access, fencing off construction area.



Engineers
Planners
Economists
Scientists

March 21, 1985

L234.32

Mr. Steven Riner
Minnesota Pollution Control Agency
Division of Solid and Hazardous Waste
1935 West County Road B-2
Roseville, Minnesota 55113-2785

RECEIVED

MAR 22 1985

MINN. POLLUTION
CONTROL AGENCY

Dear Mr. Riner:

In accordance with our discussions on March 20, I have revised the cost tables for the upcoming design of a GAC system at St. Louis Park, both of which are described in the attached task listing.

The work has been broken into a preconstruction phase and a construction phase, both of which are described in the attached task listing.

The estimated cost breakdown for the two phases is presented in the attached detailed cost summaries and is further summarized as follows:

| <u>Item</u> | <u>Preconstruction</u> | <u>Construction</u> |
|------------------|------------------------|---------------------|
| Labor | \$61,138 | \$18,001 |
| Expenses | 14,505 | 4,595 |
| Outside Services | 1,500 | 0 |
| Markup | 75 | 0 |
| Fee | <u>7,990</u> | <u>2,340</u> |
| TOTAL | \$85,923 | \$24,936 |

The estimated schedule for the project is as follows:

| <u>Item</u> | <u>Weeks After Notice to Proceed</u> |
|----------------------------|--|
| Kickoff meeting | 1/2 |
| Design Memorandum | 2-1/2 |
| Construction Bid Documents | 7 |
| Contractor Selection | 10 |
| Begin Construction | 11 |
| Construction Complete | 24-28 |

Mr. Steven Riner
Page 2
March 21, 1985
L234.32

We are ready to begin our activities as soon as we receive your authorization to proceed.

If you have any questions, please call either of us at (414) 272-2426.

Sincerely,

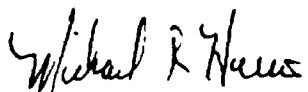

Michael R. Harris
Project Manager



Donald P. Gallo
Lead Project Engineer

jkb/GLT58/1

Enclosures

cc: Paul Bitter, Region V, EPA
Kitty Taimi, U.S. EPA

SCOPE OF WORK
Design and Construction of GAC System
Preconstruction Phase

1. Contractor shall organize and attend a kickoff meeting with MPCA staff and St. Louis Park staff to discuss the design including:
 - A. Architectural aspects of the project.
 - B. Site layout.
 - C. Design, bid and construction schedule.
 - D. Construction sequence & coordination.
 1. St. Louis Park WTP Improvements
 2. Initial Charge of Carbon

2. Contractor shall prepare a predesign memorandum comparing three potential configurations of a GAC system for treating water from SLP-15:
 - A. Two 10-foot diameter columns in parallel located downstream from the sand filters at SLP-15 (with provision to add two additional columns in the future).
 - B. Two gravity carbon filter beds, in series, located downstream from the sand filters (with provision to add a third stage in the future).
 - C. Two 16-foot-diameter columns in series located upstream from the sand filters at SLP-15 (with provision to add a third stage in the future).

For each of these three systems, the following shall be prepared.

- A. Process flow diagram from the well head to the potable water distribution system.
- B. Preliminary site layout illustrating the location of all major new facilities.
- C. Design, bidding and construction schedule.
- D. Order-of-magnitude cost estimate for design and construction of the system, including all construction oversight costs.
- E. Construction drawing sheet count and preliminary contract specifications outline.

- F. For alternatives 1 and 3, an evaluation of insulating and heat tracing the carbon columns versus housing them in a heated brick and block building.
- G. Design standards, criteria, sizing and material selection by process and facility.
- H. Evaluation of changing carbon by using a transfer tank versus two bulk delivery trucks.

When the design memorandum is completed, contractor shall present the memorandum in a progress review meeting with MPCA staff and St. Louis Park staff to discuss the conclusions and results of this preliminary analysis. MPCA will direct the contractor to proceed with design of one of the three systems at the conclusion of the meeting.

3. Final Design Services

The design cost estimated is for the system described in CH2M HILL's 1983 report to MPCA. If a different system is selected in Task 2, the design costs will be adjusted accordingly.

The design will be expedited to be completed in the shortest feasible timeframe. Overtime work schedules and use of staff from other offices will be used to fast-track the design.

- A. Contractor shall prepare bidding documents, construction drawings, and specifications, as customarily made available for this type of project, for the following facilities:
 - 1. (3) carbon columns
 - 2. (1) carbon transfer tank, (if justified in task 2-H)
 - 3. (4) wall mounted minicolumns
 - 4. Building addition to the existing pump station at well Nos. 11 and 15
 - 5. Miscellaneous yard piping including a new carbon column backwash line and a chlorine solution line.
 - 6. Chlorination system modifications to permit periodic Cl_2 dosage of carbon columns
 - 7. New driveway for access to the carbon transfer tank

- 8. Associated electrical and instrumentation equipment
- B. Furnish (30) copies of drawings, specifications and contract documents for required Owner and regulatory agency approvals.
- C. Contractor shall provide assistance in securing bids, including:
 - 1. Interpret drawings and specification during bidding.
 - 2. Prepare and distribute addenda.

4. Other Services

- A. Geotechnical Investigation. Contractor shall furnish personnel and equipment required to perform subsurface exploration necessary for determining geologic foundation and construction conditions.
- B. Contractor shall provide 5 copies of an operations manual describing the operation of the completed GAC water treatment system. This manual shall explain the various modes of operation which may be possible, including, but not limited to, both normal operation and emergency operation procedures. The manual shall be complete with schematic drawings showing possible fluid routes and capacities, and shall explain the purposes and theory of the process. It shall include instructions for each subprocess operation and shall contain instructions for test or laboratory procedures that may be required to monitor the performance. The manual shall be suitable for use as an operational tool and a textbook to facilitate operator training.
- C. Contractor shall provide 5 bound copies of complete manufacturer's maintenance instructions for all mechanical equipment which is installed. The maintenance instructions shall include lubrication schedules, recommended lubricants, recommended inspection or service procedures, and such other information as may be required to facilitate equipment maintenance.

SCOPE OF WORK
Design and Construction of GAC System
Construction Phase

1. Engineering Services - Construction Phase

- A. Contractor shall interpret drawings and specifications during construction and evaluate requests to deviate from designs and/or specifications.
- B. Selected members of the contractor's design team shall make periodic visits to the site of the Project to observe the progress and quality of the work and to determine if the work is proceeding in accordance with the intent of the contract documents.
- C. Contractor shall review shop drawings, diagrams, illustrations, catalog data, schedules, and samples, the results of tests and inspections, and other data which the construction contractors are required to submit for conformance with the design concept of the Project and compliance with the information given in the contract documents.
- D. Contractor shall compare the progress and quality of work performed by the construction contractor to the requests for progress payments. Contractor shall provide assistance to the State in determining the amounts of progress payments due to the construction contractor.
- E. Contractor shall negotiate with the construction contractor the scope and cost of any necessary contract change orders and prepare such change orders as may be required for the State to issue.

2. Operations Services

- A. After completion of the Project and acceptance from the construction contractor by the State, the contractor shall provide assistance to train the City's personnel for operation and maintenance of the new facilities.

Assumptions Used in Development
of the Engineering Fee Estimate

1. The kickoff meeting will be attended by the and Project Manager and Lead Project Engineer.
2. The predesign memorandum will be prepared and submitted within (10) calendar days of the kickoff meeting. Review comments are needed from the State within (5) calendar days of receipt of the pre-design memorandum. The design will be initiated immediately following the kickoff meeting and rapid response to the design team will be of the essence.
3. The State and the City of St. Louis Park will make available to the contractor all project pertinent technical data in their possession, including:
 - a. Site maps, boundary surveys, topographic surveys, record drawings of existing facilities, soil borings and geotechnical reports. All such information will be turned over to contractor at the kickoff meeting.
4. It is assumed that structural and electrical drawings of the existing facilities are adequate and that discipline design staff will have to visit the site only one time.
5. The structural design effort is based on spread footings and no allowance has been made for unusual soil conditions which may require further detailed analysis and design.
6. The electrical design effort is based on the existing electrical service being of adequate capacity to handle the power load and circuit requirements of this project.
7. The design effort is based on preparing one set of completed contract documents. Preliminary sheet counts and a preliminary specification listing are attached. Contractor will also develop the material specifications, conditions of delivery and contract for the initial charge of granular activated carbon. Contractor will assist in contract negotiations with Calgon as needed to support the State in securing a purchase agreement. It is assumed that the State will authorize a sole-source purchase from Calgon.
8. A review of documents by the State and City staff is anticipated at 75 percent completion of the

design effort. Review comments are needed within (3) calendar days of receipt of documents. The design team will continue to proceed with the design and incorporate review comments as they are received.

9. Assistance during the bidding phase assumes that either the City or the State will directly handle advertisements for bidding, distribution of contract documents and addenda, and opening of bids. The Contractor will tabulate and review bids, make a recommendation for selection of construction contractor(s), assist in awarding the contract(s), conduct a preconstruction conference, and issue Notice(s) to Proceed.
10. It has been assumed that the City will provide on-the-job, day-to-day observation of the Project during construction. The design team will be available to answer questions regarding interpretation of drawings and specifications. Monthly onsite visits by the project manager and/or one member of the design team have been assumed. (Total of 5 MD's estimated).
11. Effort required to review the construction contractor's submittals is highly variable and depends upon the quality of the submittal information. It has been estimated that twenty (20) submittal packages will be received from the construction contractors. This estimate includes a second submittal required on 25 percent of the original submittals.
12. The estimate includes providing assistance on five (5) progress payment reviews and two (2) final payment reviews.
13. The estimate includes an allowance for two (2) change orders, with onsite negotiation meetings with the construction contractor. These changes order may consist of more than work order each.
14. The estimate includes 1 manday of operations and maintenance training.
15. The geotechnical services have been estimated using a local drilling contractor and a CH2M HILL engineer onsite for one day. The depth of boring is estimated at 50 lineal feet, no lab testing is estimated. A technical memorandum will be prepared and soil samples will be taken in case soil analyses becomes necessary.

GLT58/2

GLT58/2

ST. LOUIS PARK
PRELIMINARY CONSTRUCTION DRAWING
SHEET LISTING

St. Louis Park WTP Improvements

1. Cover Sheet and Site Plan
2. Site Legend
3. Site Plan and Yard Piping
4. Building Addition Foundation Plan, Floor Plan
5. Building Addition Roof Plan, Wall Sections
6. Carbon Tanks Foundation Plan, Sections and Footing
Details
7. Carbon Tanks - Plan, Sections & Details
8. Carbon Tanks - Mechanical Piping Sections and Details
9. Chlorination System Modifications, Sections and Details
10. Electrical Legend
11. Electrical
12. Structural and Architectural Details
13. Site and Mechanical Details
14. Electrical Details

ST. LOUIS PARK
PRELIMINARY SPECIFICATION LISTING

St. Louis Park GAC System

PART I - Bidding Requirements

| | |
|-------|-------------------------|
| 00125 | Fly Sheet |
| 00200 | Contents |
| 00350 | Invitation to Bid |
| 00405 | Instructions to Bidders |
| 00480 | Proposal |
| 00555 | Bid Bond |

PART II - Contract Forms

| | |
|-------|------------------|
| 00585 | Contract |
| 00670 | Performance Bond |
| 00675 | Payment Bond |

PART III - Conditions of Contract

| | |
|-------|-------------------------|
| 00750 | General Conditions |
| 00790 | Supplemental Conditions |

PART IV - Technical Specifications

Foreword

Division 1 - General Requirements

| | |
|-------|----------------------|
| 01001 | General Requirements |
|-------|----------------------|

Division 2 - Site Work

| | |
|-------|--------------------------------|
| 02015 | Move In & Site Preparation |
| 02050 | Demolition |
| 02102 | Clearing, Grubbing & Stripping |
| 02200 | Earthwork |
| 02500 | Access Road |
| 02590 | Well Disinfection |

Division 3 - Concrete

| | |
|-------|---------------------------------|
| 03210 | Reinforcing Steel |
| 03251 | Expansion & Construction Joints |
| 03300 | Concrete |

Division 4 - Masonry

| | |
|-------|--------------------------------|
| 04230 | Reinforced Hollow Unit Masonry |
| 04252 | Masonry Veneer |

Division 5 - Metals

| | |
|-------|---|
| 05120 | Structural Steel |
| 05300 | Metal Decking and Open-Web Steel Joists |
| 05500 | Fabricated Metalwork and Castings |

Division 6 - Not used

Division 7 - Thermal & Moisture Protection

| | |
|-------|-------------------------|
| 07194 | Underslab Vapor Barrier |
|-------|-------------------------|

| | |
|-------------|---------------------------------------|
| 07210 | Building Insulation |
| 07510 | Builtup Bituminous Roofing |
| 07600 | Flashing & Sheet Metal |
| 07900 | Sealants |
| Division 8 | - Doors & Windows |
| 08100 | Metal Doors and Frames |
| 08520 | Aluminum Windows |
| 08800 | Glazing |
| Division 9 | - Finishes |
| 09900 | Painting |
| Division 10 | - Not used |
| Division 11 | - Equipment |
| 11360 | Chlorine System Modifications |
| 11390 | Granular Activated Carbon |
| | Adsorption Columns & Transfer Tank |
| 11391 | Granular Activated Carbon Minicolumns |
| Division 12 | - Not used |
| Division 13 | - Special Construction |
| 13700 | Process Instrumentation & Controls |
| Division 14 | - Not used |
| Division 15 | - Mechanical |
| 15000 | Piping |
| 15100 | Valves & Appurtenances |
| 15400 | Plumbing |
| Division 16 | Electrical |
| 16010 | Electrical - General Provisions |
| 16050 | Basic Materials and Methods |
| 16110 | Raceways |
| 16120 | Conductors |
| 16450 | Grounding |
| 16500 | Lighting |

GLT58/3

TABLE 1
 CMEN DETAILED COST SUMMARY
 ST LOUIS PARK BAC SYSTEM
 PRE-CONSTRUCTION SERVICES

| TASK NO. TASK | 1 KICKOFF MEETING | 2 DESIGN MEMO | 3 DESIGN SERVICES | | | | 4 OTHER SERVICES | | TOTAL |
|--|-------------------------|---------------------|----------------------|--------------------|-------------------|-------------------|-------------------------------|--------------------|-----------------|
| | | | CONTRACT | CARBON CONTRACT | BID PERIOD | O & M MANUAL | GEOTECHNICAL INVESTIGATION | | |
| SUBTASK NO. SUBTASK | | | | | | | | | |
| LABOR (HOURS) | | | | | | | | | |
| MICHAEL R. HARRIS | 8 | 8 | 40 | 16 | 0 | 4 | 0 | 76 | |
| DONALD P. BALLO | 8 | 32 | 88 | 8 | 16 | 8 | 0 | 160 | |
| JOHN WISKUS/ALAN SCRIVNER | 0 | 80 | 180 | 0 | 0 | 30 | 0 | 290 | |
| ROBERTA D. PERRY | 0 | 16 | 56 | 8 | 0 | 0 | 0 | 80 | |
| ROBERT C. JANKE | 0 | 16 | 96 | 0 | 0 | 0 | 0 | 112 | |
| RICHARD H. SMITH | 0 | 8 | 16 | 0 | 0 | 0 | 0 | 24 | |
| THOMAS C. MONTGOMERY | 0 | 8 | 72 | 0 | 0 | 0 | 0 | 80 | |
| BRUCE L. CUTRIGHT | 0 | 0 | 16 | 0 | 0 | 0 | 0 | 16 | |
| EDWARD F. SHOREY | 0 | 0 | 0 | 0 | 0 | 0 | 24 | 24 | |
| BARRY OHLSSON | 0 | 0 | 12 | 0 | 0 | 0 | 0 | 12 | |
| TECHNICIAN | 0 | 16 | 350 | 0 | 4 | 16 | 4 | 390 | |
| WORD PROCESSING | 0 | 4 | 50 | 8 | 4 | 6 | 4 | 76 | |
| TOTAL LABOR (HOURS) | 16 | 188 | 976 | 40 | 24 | 64 | 32 | 1340 | |
| LABOR DOLLARS @ 2.63 1985 RATES | | | | | | | | | |
| MICHAEL R. HARRIS | \$71.24 | \$569.92 | \$2,049.60 | \$1,139.84 | \$0.00 | \$284.96 | \$0.00 | \$5,414.24 | |
| DONALD P. BALLO | \$57.66 | \$461.28 | \$1,074.08 | \$461.28 | \$922.56 | \$461.28 | \$0.00 | \$5,225.60 | |
| JOHN WISKUS/ALAN SCRIVNER | \$44.24 | \$0.00 | \$7,963.20 | \$0.00 | \$0.00 | \$1,327.20 | \$0.00 | \$12,829.60 | |
| ROBERTA D. PERRY | \$40.67 | \$0.00 | \$2,277.52 | \$325.36 | \$0.00 | \$0.00 | \$0.00 | \$3,253.60 | |
| ROBERT C. JANKE | \$57.13 | \$0.00 | \$5,484.48 | \$0.00 | \$0.00 | \$0.00 | \$0.00 | \$6,398.56 | |
| RICHARD H. SMITH | \$62.36 | \$0.00 | \$997.76 | \$0.00 | \$0.00 | \$0.00 | \$0.00 | \$1,496.64 | |
| THOMAS C. MONTGOMERY | \$61.15 | \$0.00 | \$4,402.80 | \$0.00 | \$0.00 | \$0.00 | \$0.00 | \$4,892.00 | |
| BRUCE L. CUTRIGHT | \$59.78 | \$0.00 | \$956.48 | \$0.00 | \$0.00 | \$0.00 | \$0.00 | \$956.48 | |
| EDWARD F. SHOREY | \$35.46 | \$0.00 | \$0.00 | \$0.00 | \$0.00 | \$0.00 | \$1,331.04 | \$1,331.04 | |
| BARRY OHLSSON | \$52.27 | \$0.00 | \$627.24 | \$0.00 | \$0.00 | \$0.00 | \$0.00 | \$627.24 | |
| TECHNICIAN | \$33.46 | \$0.00 | \$11,711.00 | \$0.00 | \$133.84 | \$535.36 | \$133.84 | \$13,049.40 | |
| WORD PROCESSING | \$26.10 | \$0.00 | \$1,305.00 | \$208.80 | \$104.40 | \$156.60 | \$104.40 | \$1,963.60 | |
| TOTAL LABOR (DOLLARS) | | \$1,031.20 | \$9,649.16 | \$2,135.28 | \$1,160.80 | \$2,765.40 | \$1,569.28 | \$61,458.00 | |
| EXPENSE ITEMS | | | | | | | | | |
| TRANSPORTATION | | \$650 | \$3,970 | \$330 | \$0 | \$0 | \$330 | \$5,880 | |
| SUBSISTENCE | | \$25 | \$1,980 | \$15 | \$0 | \$0 | \$50 | \$2,770 | |
| OTHER DIRECT COSTS (ODC) | | | | | | | | | |
| POSTAGE/FREIGHT | | \$0 | \$100 | \$100 | \$300 | \$100 | \$25 | \$1,225 | |
| SUPPLIES | | \$0 | \$750 | \$20 | \$50 | \$100 | \$0 | \$945 | |
| COMPUTER | | \$0 | \$1,500 | \$50 | \$40 | \$200 | \$30 | \$1,895 | |
| REPRODUCTION | | \$0 | \$600 | \$50 | \$150 | \$100 | \$25 | \$940 | |
| OTHER | | \$25 | \$700 | \$100 | \$200 | \$100 | \$20 | \$1,245 | |
| TOTAL ODC | | \$25 | \$4,150 | \$320 | \$740 | \$600 | \$100 | \$6,550 | |
| TOTAL EXPENSE COST (DOLLARS) | | \$700 | \$10,100 | \$655 | \$740 | \$600 | \$480 | \$14,900 | |
| SUBCONTRACTS | | | | | | | | | |
| DRILLING CONTRACTOR | | \$0 | \$0 | \$0 | \$0 | \$0 | \$1,500 | \$1,500 | |
| FEE | | | | | | | | | |
| LABOR | RATE= | 0.130 | \$134 | \$1,189 | \$5,674 | \$278 | \$151 | \$360 | \$7,990 |
| SUBCONTRACTS | RATE= | 0.050 | \$0 | \$0 | \$0 | \$0 | \$0 | \$75 | \$75 |
| TOTAL FEE (DOLLARS) | | | \$134 | \$1,189 | \$5,674 | \$278 | \$151 | \$435 | \$8,065 |
| TOTAL EST. SUBTASK COST | | | \$1,865 | \$11,951 | \$59,424 | \$3,078 | \$3,725 | \$3,828 | \$85,923 |

TABLE 2
 CHEN DETAILED COST SUMMARY
 ST LOUIS PARK GAC SYSTEM
 CONSTRUCTION SERVICES

| TASK NO. TASK | 1 CONSTRUCTION PHASE | | | | | 2 OPERATIONAL SERVICES | | | TOTAL | |
|---------------------------------|-------------------------|-------------------------|------------------|---------------------|------------------|----------------------------|---------------------|------------|-------------|----------|
| | DOCUMENT INTERP. | PERIODIC SITE VISITS | SHOP DRAWINGS | PROGRESS REVIEWS | CHANGE ORDERS | MAINTENANCE INSTRUCTION | ON-SITE TRAINING | | | |
| LABOR (HOURS) | | | | | | | | | | |
| MICHAEL R. HARRIS | 0 | 8 | 0 | 0 | 0 | 0 | 0 | 0 | 8 | |
| DONALD P. GALLO | 30 | 16 | 44 | 24 | 16 | 0 | 8 | 0 | 138 | |
| JOHN WISKIUS/ALAN SCRIVNER | 0 | 0 | 0 | 0 | 0 | 0 | 0 | 0 | 0 | |
| ROBERTA D. PERRY | 4 | 8 | 40 | 8 | 8 | 8 | 16 | 0 | 92 | |
| ROBERT C. JANKE | 16 | 8 | 12 | 0 | 0 | 0 | 0 | 0 | 36 | |
| RICHARD H. SMITH | 8 | 0 | 0 | 0 | 0 | 0 | 0 | 0 | 8 | |
| THOMAS C. MONTBOMERY | 16 | 0 | 8 | 0 | 0 | 0 | 0 | 0 | 24 | |
| BRUCE L. CUTRIGHT | 0 | 0 | 0 | 0 | 0 | 0 | 0 | 0 | 0 | |
| EDWARD F. SHOREY | 0 | 0 | 0 | 0 | 0 | 0 | 0 | 0 | 0 | |
| BARRY OHLSSON | 4 | 0 | 4 | 0 | 0 | 0 | 0 | 0 | 8 | |
| TECHNICIAN | 0 | 0 | 24 | 0 | 6 | 0 | 0 | 0 | 30 | |
| WORD PROCESSING | 0 | 0 | 0 | 8 | 3 | 0 | 0 | 0 | 11 | |
| TOTAL LABOR (HOURS) | 78 | 40 | 132 | 40 | 33 | 8 | 24 | 0 | 355 | |
| LABOR DOLLARS @ 2.63 1985 RATES | | | | | | | | | | |
| MICHAEL R. HARRIS | \$71.24 | \$0.00 | \$569.92 | \$0.00 | \$0.00 | \$0.00 | \$0.00 | \$0.00 | \$569.92 | |
| DONALD P. GALLO | \$57.66 | \$1,729.80 | \$922.56 | \$2,537.04 | \$1,383.84 | \$922.56 | \$0.00 | \$461.28 | \$7,957.08 | |
| JOHN WISKIUS/ALAN SCRIVNER | \$44.24 | \$0.00 | \$0.00 | \$0.00 | \$0.00 | \$0.00 | \$0.00 | \$0.00 | \$0.00 | |
| ROBERTA D. PERRY | \$40.67 | \$162.68 | \$325.36 | \$1,626.80 | \$325.36 | \$325.36 | \$325.36 | \$650.72 | \$3,741.64 | |
| ROBERT C. JANKE | \$57.13 | \$914.08 | \$457.04 | \$685.56 | \$0.00 | \$0.00 | \$0.00 | \$0.00 | \$2,056.68 | |
| RICHARD H. SMITH | \$62.36 | \$498.88 | \$0.00 | \$0.00 | \$0.00 | \$0.00 | \$0.00 | \$0.00 | \$498.88 | |
| THOMAS C. MONTBOMERY | \$61.15 | \$978.40 | \$0.00 | \$489.20 | \$0.00 | \$0.00 | \$0.00 | \$0.00 | \$1,467.60 | |
| BRUCE L. CUTRIGHT | \$59.78 | \$0.00 | \$0.00 | \$0.00 | \$0.00 | \$0.00 | \$0.00 | \$0.00 | \$0.00 | |
| EDWARD F. SHOREY | \$55.46 | \$0.00 | \$0.00 | \$0.00 | \$0.00 | \$0.00 | \$0.00 | \$0.00 | \$0.00 | |
| BARRY OHLSSON | \$52.27 | \$209.08 | \$0.00 | \$209.08 | \$0.00 | \$0.00 | \$0.00 | \$0.00 | \$418.16 | |
| TECHNICIAN | \$33.46 | \$0.00 | \$0.00 | \$803.04 | \$0.00 | \$200.76 | \$0.00 | \$0.00 | \$1,003.80 | |
| WORD PROCESSING | \$26.10 | \$0.00 | \$0.00 | \$208.80 | \$78.30 | \$0.00 | \$0.00 | \$0.00 | \$287.10 | |
| TOTAL LABOR (DOLLARS) | | \$4,492.92 | \$2,274.88 | \$6,350.72 | \$1,918.00 | \$1,526.98 | \$325.36 | \$1,112.00 | \$18,000.86 | |
| EXPENSE ITEMS | | | | | | | | | | |
| TRANSPORTATION | | \$0 | \$1,500 | \$0 | \$0 | \$0 | \$0 | \$330 | \$1,830 | |
| SUBSISTENCE | | \$0 | \$250 | \$0 | \$0 | \$0 | \$0 | \$120 | \$370 | |
| OTHER DIRECT COSTS (ODC) | | | | | | | | | | |
| POSTAGE/FREIGHT | | \$175 | \$0 | \$250 | \$50 | \$20 | \$50 | \$0 | \$545 | |
| SUPPLIES | | \$0 | \$0 | \$50 | \$50 | \$50 | \$30 | \$0 | \$180 | |
| COMPUTER | | \$40 | \$0 | \$200 | \$125 | \$50 | \$0 | \$0 | \$415 | |
| REPRODUCTION | | \$25 | \$0 | \$150 | \$30 | \$50 | \$50 | \$0 | \$305 | |
| OTHER | | \$250 | \$150 | \$250 | \$100 | \$100 | \$50 | \$50 | \$950 | |
| TOTAL ODC | | \$490 | \$150 | \$900 | \$355 | \$270 | \$180 | \$50 | \$2,395 | |
| TOTAL EXPENSE COST (DOLLARS) | | \$490 | \$1,900 | \$900 | \$355 | \$270 | \$180 | \$500 | \$4,595 | |
| SUBCONTRACTS | | | | | | | | | | |
| DRILLING CONTRACTOR | | \$0 | \$0 | \$0 | \$0 | \$0 | \$0 | \$0 | \$0 | |
| FEE | | | | | | | | | | |
| LABOR | RATE= | 0.130 | \$384 | \$296 | \$826 | \$249 | \$199 | \$42 | \$145 | \$2,340 |
| SUBCONTRACTS | RATE= | 0.050 | \$0 | \$0 | \$0 | \$0 | \$0 | \$0 | \$0 | \$0 |
| TOTAL FEE (DOLLARS) | | | \$384 | \$296 | \$826 | \$249 | \$199 | \$42 | \$145 | \$2,340 |
| TOTAL EST. SUBTASK COST | | | \$5,567 | \$4,471 | \$8,076 | \$2,522 | \$1,995 | \$548 | \$1,757 | \$24,936 |

Table 8-1
 WATER SUPPLY ALTERNATIVES
 SUMMARY OF COSTS

| <u>Alter- native</u> | <u>Capital Cost</u> | <u>Amoritized Capital Cost</u> | <u>Annual O&M Cost</u> | <u>Total Annual Cost</u> |
|--------------------------|-------------------------|--|------------------------------------|----------------------------------|
| 1 | \$ 761,000 | \$ 76,800 | \$152,100 to 225,000 | \$228,900 to 302,500 |
| 2 | 250,000 | 25,200 | 833,000 | 858,200 |
| 3 | 1,870,000 | 188,700 | 122,000 | 310,700 |

GLT233/12

Section 8
EVALUATION OF ALTERNATIVE WATER SUPPLIES

BASIS FOR EVALUATION

To provide a common basis for evaluating water supply, alternatives for the city of St. Louis Park, the following objectives were established.

Capacity

The total instantaneous supply capacity of each alternative must be 3,400 gpm to make up the shortfall between the existing capacity of 9,200 gpm and the pre-1978 capacity of 12,600 gpm. (Note that the existing capacity of 9,200 gpm includes a new municipal well, SLP 17, in the Mt. Simon/Hinckley aquifer and an interconnection with Plymouth, both of which have been installed since the well closures in 1978).

Annual Cost

In computing the annual cost of alternatives, it has been assumed that 1,200 gpm of additional water supplies must be provided year round and that the additional 2,200 gpm peaking capacity would be necessary three weeks per year. This 2,200 gpm would be equivalent to historical uses of SLP-7 and -9 during hot summer days when sprinkling usage is high.

Quality

The alternative must provide a water supply of roughly the same quality as existed prior to PAH contamination of St. Louis Park's wells. If, for example, iron removal facilities would be required to provide an equivalent water supply, the capital and annual O&M cost of such facilities must be included in the alternative.

Three alternatives which fulfill the above objectives were identified. The following sections describe each alternative.

ALTERNATIVE 1 - TREAT SLP-15 FOR POTABLE SUPPLY AND START UP SLP-7 AND -9

Pilot-scale test work completed during this project demonstrated that, if treated in a granular activated carbon treatment system, PAH concentrations in water from SLP-15 can be reduced to well below goals established by the Minnesota Department of Health.

If SLP-15 can be started up, the MPCA and MDH have determined that SLP-7 and -9 could be started up without treatment. The cone of depression created by SLP-15 would "block" the passage of the contaminant plume to SLP-7 and -9.

The basic features of the system are as follows:

- o Water pumped from SLP-15 (1,200 gpm) would be treated in a GAC treatment system for removal of PAH's and other coal tar derivatives.
- o Treated water would be routed to the existing iron removal system located near SLP-15.
- o SLP-10 would be piped into the GAC system to provide a backup water source in the event SLP-15 breaks down. SLP-10 and SLP-15 could be operated individually or together providing the combined flow rate does not exceed 1,200 gpm.
- o SLP-7 and -9 (2,200 gpm) would be turned on as necessary to provide additional water supplies to the City during peak water demand periods.

No capital expenditures will be necessary to start up SLP-7 and -9. MDH has indicated that some sampling and analytical work will be necessary prior to startup of these wells, but it has been assumed that the cost of such testing will be charged against the gradient control system. Some additional annual O&M costs will be incurred to operate these wells during peak water demand periods. MDH has also indicated that weekly testing for PAH's will be required for each well when the wells are in operation (i.e., six tests per year).

The total estimated capital cost for this alternative is \$655,000. The estimated annual O&M cost is from \$152,100 to \$225,700 (annual O&M costs are presented as a range because of uncertainties regarding carbon life).

Advantages of this system include:

- o Operation of SLP-15 will provide a barrier to further migration of the contaminated groundwater plume. Since SLP-15 would have to be operated (and potentially treated) regardless of the water supply alternative selected, operation of this pump serves a dual purpose:
- o Responsibility for operation lies entirely with city of St. Louis Park staff.
- o Assuming proper operation of the system, the water supply is completely dependable.
- o The cost to operate the system would be relatively stable, subject only to fluctuations in labor rates, electrical rates, and carbon prices.

Disadvantages of the system include:

- o If the treatment system at SLP-10 and -15 is out of service for an extended period of time during peak water demand periods, SLP-7 and -9 will not be available for use. Since SLP-10 provides a backup water supply at the treatment system and the GAC system is relatively simple, this should not be a major problem.

ALTERNATIVE 2 - INSTALL INTERCONNECTION WITH CITY OF MINNEAPOLIS WATER DISTRIBUTION SYSTEM

The city of St. Louis Park is preparing an evaluation of the feasibility and costs associated with installing an interconnection with the potable water distribution system in Minneapolis.

The basic features of the system are as follows:

- o An interconnection between the two distribution systems would be made near Cedar Lake Road and France Avenue in the northeast corner of St. Louis Park.
- o Since St. Louis Park's distribution system operates at a higher pressure than Minneapolis's distribution system, a booster pump station would be required.
- o The Minneapolis water system would serve as the sole source of water for the portion of St. Louis Park located east of Highway 100, a population of approximately 11,000 people.
- o The city of St. Louis Park would pay Minneapolis for water consumption at a rate of \$0.94/100 ft³.

The total estimated capital cost for this alternative is \$250,000. The estimated annual O&M cost is \$833,000. The bulk of annual O&M costs are water charges from Minneapolis.

Advantages of this system include:

- o This system could be designed and started up quickly.
- o This system has the lowest capital cost of any of the alternatives.
- o The Minneapolis water is softened, whereas St. Louis Park's water is not. Not all citizens, however, may want softened water, and those who do probably already have home softeners.

Disadvantages of this system include:

- o Total annual costs are more than for any other alternative.
- o Some areas of reduced water pressure or stagnation may occur west of Highway 100.
- o Some concern has been expressed that the Minneapolis water system does not have a backup water supply if low Mississippi River flows occur. In addition, Minneapolis has a limited storage capacity, similar to most mature cities with surface water supplies.
- o The Minneapolis intake structure is downriver from a hazardous waste site in Fridley, Minnesota. Although the potential is very low, there is a remote possibility of future problems with water quality in the Minneapolis supply system. It should be noted, however, that the system has the capability to add powdered activated carbon, reducing concerns over potential organic contaminants released from the upriver site.
- o Even if this alternative were implemented, SLP-15 would have to be started up and, potentially, treated as a part of the gradient control network now under evaluation by MPCA. The costs of starting up and operating SLP-15 are not included in the cost of this alternative.

ALTERNATIVE 3 - INSTALL WELLS IN MT. SIMON/HINCKLEY AQUIFER

The city of St. Louis Park has already installed one new, deep well in the Mt. Simon/Hinckley aquifer. This new well is scheduled for startup in June 1983. Installation of more wells in the deeper aquifer is a feasible alternative to provide additional potable water for St. Louis Park.

The basic features of the system are as follows:

- o Three Mt. Simon/Hinckley wells would be required to provide the 3,400 gpm capacity requirement (1,200 gpm continuous flow plus 2,200 gpm peaking capacity). Well construction requirements would be similar to the most recent city well. It has been assumed that two completely new wells would be constructed and that one existing, abandoned, well (SLP-7) would be drilled deeper to the Mt. Simon/Hinckley aquifer. Since drilling of very deep wells involves a number of unknowns, this represents a minimum number of deep wells.
- o One of the new wells would be routed through the existing iron removal treatment system near SLP-15,

utilizing capacity which was formerly allocated to SLP-10 and -15.

- o Since the remaining wells would be used only for brief periods in the summer, it has been assumed that iron removal facilities would not be required for the additional wells.

The total estimated capital cost for this alternative is \$1,870,000. The estimated annual O&M cost is \$122,000.

Advantages of this system include:

- o No new water treatment facilities would be required.
- o Responsibility for operation lies entirely with city of St. Louis Park staff.
- o The cost to operate and maintain the system should be relatively stable, subject only to fluctuations in labor and electrical rates.
- o Water in the Mt. Simon/Hinckley is somewhat softer than water in the upper aquifers (but iron concentrations are similar).

Disadvantages of this system include:

- o Three new wells will have to be drilled through the confining layer between the Prairie du Chein-Jordan aquifer and the Mt. Simon/Hinckley aquifer. Regardless of the precautions taken in well installation, these new wells will represent potential long-term pathways for cross contamination between aquifers.
- o Construction of the new wells would probably not be permitted until after extensive modeling of the lower aquifer. This modeling would be necessary to ensure that the long term yield of other wells in the aquifer would not be adversely affected by the new wells.
- o Even if this alternative were implemented, SLP-15 would have to be started up and, potentially, treated as a part of the gradient control network now under evaluation by MPCA. The costs of starting up and operating SLP-15 are not included in the cost of this alternative.

FINANCIAL ANALYSIS OF ALTERNATIVES

The following assumptions were made to compare the costs of the alternatives.

- o Capital costs will be amortized at 7-7/8 percent over 20 years with zero assumed salvage value.
- o No costs of using SLP-15 for gradient control will be added to Alternatives 2 and 3. Such costs would, however, be necessary to compensate for the gradient control benefits which are implicit with Alternative 1.

Table 8-1 presents a financial comparison of the three alternatives.

REFERENCES

The material discussed in this section is presented in detail in Technical Memoranda L and O/P.

GLT233/7

Section 9
SELECTION OF WATER SUPPLY ALTERNATIVE FOR
ST. LOUIS PARK

INTRODUCTION

Three viable water supply alternatives were identified in Section 8:

1. Treat SLP-15 for potable supply and start up SLP-7 and -9.
2. Install interconnection with City of Minneapolis water distribution system.
3. Install wells in Mt. Simon/Hinckley aquifer.

Each alternative would restore St. Louis Park's potable water supply capacity to pre-1978 levels, when municipal wells were first shut down because of PAH contamination. Alternative 2 has excessive annual costs and was rejected for financial reasons. Alternative 1 is far less capital intensive than Alternative 3, but would be more expensive to operate each year. However, when both amortized capital and annual O&M costs are considered, Alternative 1 is the most cost-effective alternative, regardless of carbon consumption.

LONG RANGE IMPACTS OF SELECTED ALTERNATIVE ON WATER SUPPLY

Analysis of water supply alternatives has centered on restoring St. Louis Park's water supply capacity to 1978 levels. Before making a final recommendation for implementation, however, it is appropriate to evaluate whether the most cost-effective alternative is compatible with future growth of the potable water supply system at St. Louis Park, if this should ever become necessary.

If Alternative 1 is implemented, there are a number of options available for future increases in water supply capacity:

- o Install GAC systems at other wells (SLP-4, -5) which have been shut down. (At current levels of contamination, it is possible that SLP-4 could be started up with only the addition of an iron removal system equipped with ozonation.)
- o Install new Mt. Simon/Hinckley wells.
- o Tie gradient control wells (if free of PAH's) into potable supply system.

It is concluded that Alternative 1 is compatible with future increases to the city's water supply capacity.

RECOMMENDATION FOR IMPLEMENTATION

Alternative No. 1 - Treatment of SLP-15 for Potable Supply and Start Up SLP-7 and -9 - is recommended for implementation at St. Louis Park, Minnesota.

In addition to being the most cost-effective alternative for restoration of water supply capacity to St. Louis Park, Alternative 1 provides additional benefits to MPCA's overall efforts at the Reilly Tar site:

- o Operation of SLP-15 will be an integral part of the gradient control network to be installed in St. Louis Park. Use of this well for potable water supply provides dual benefits.
- o MPCA has indicated that treatment of contaminated water from the gradient control system may be necessary to meet surface water discharge standards. A GAC system or other type of treatment system at SLP-15 could possibly be required even for surface water discharge. Installation of the system to provide a potable water supply for St. Louis Park is highly practical because the treated water will be beneficially used rather than discharged to surface waters.

CONCEPTUAL DESIGN OF SELECTED ALTERNATIVE





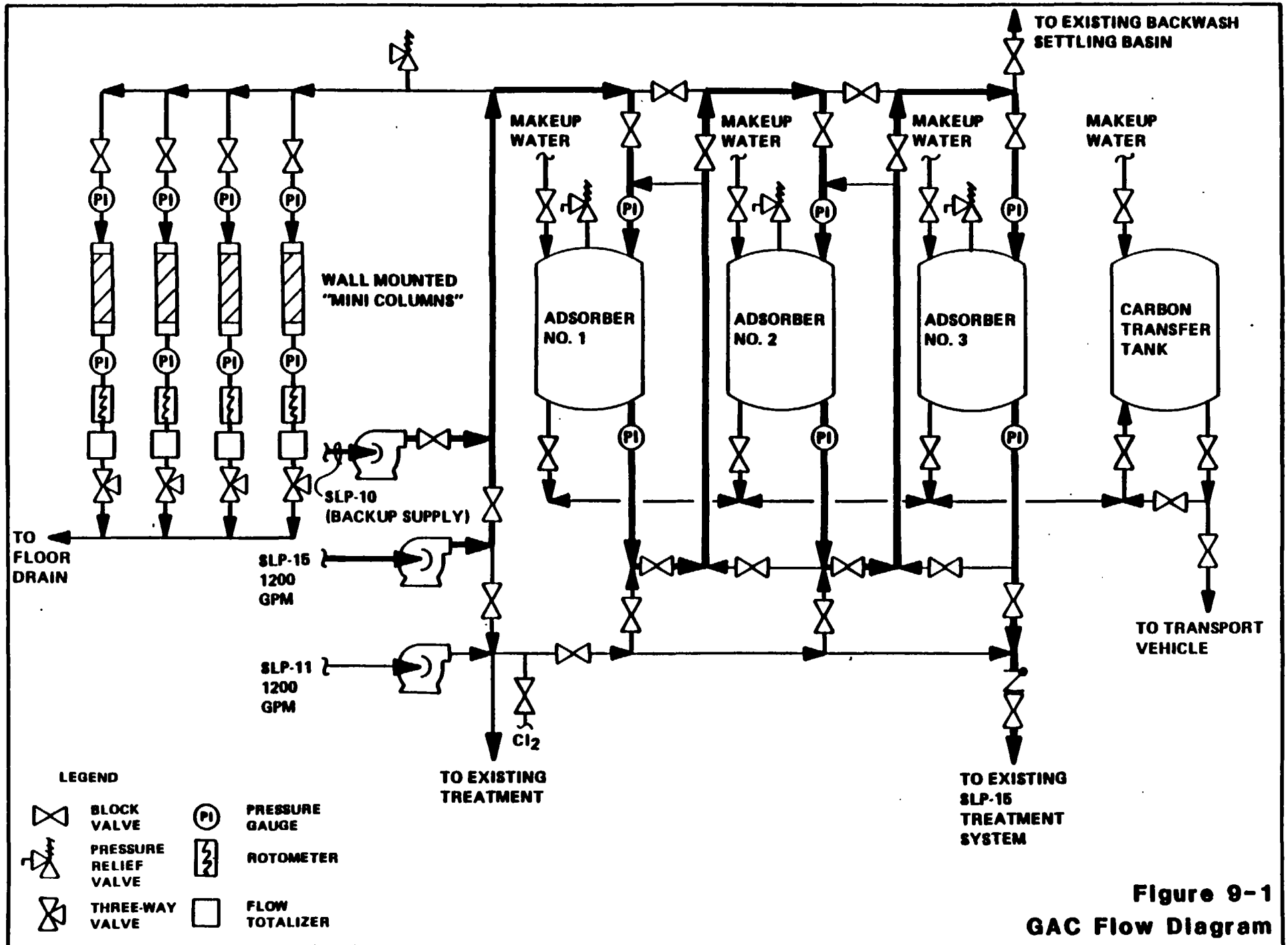

Flowsheet

Figure 9-1 is a preliminary flowsheet for a GAC treatment system at SLP-15. Basic features of the system shown are:

- o Design flow rate of 1,200 gpm
- o Three adsorption columns
- o Minicolumns for testing alternative carbons for future carbon replacement
- o Backwash provided by the combined flow of SLP-11 and -15
- o Pipe from SLP-10 to the new system to serve as a backup water supply
- o Provisions for slug dosages of chlorine (during backwash) to control biological growths in the columns.



LEGEND

- | | | | |
|---|-----------------------|---|----------------|
|  | BLOCK VALVE |  | PRESSURE GAUGE |
|  | PRESSURE RELIEF VALVE |  | ROTOMETER |
|  | THREE-WAY VALVE |  | FLOW TOTALIZER |

**Figure 9-1
GAC Flow Diagram**

Site Plan

Figure 9-2 presents a preliminary site plan for a full-scale GAC treatment system. The system has been located adjacent to the existing pump station which houses SLP-11 and -15. Basic features of the system are as follows:

- o The carbon columns and carbon transfer tanks will be heat traced and insulated and will be located outside the existing pump station building.
- o A small building addition will be necessary to house the system valving manifold, system control panel, and the wall mounted minicolumns.
- o Carbon column backwash piping will be tied in with the existing sand filter backwash system.
- o A new driveway will be necessary to provide access to the carbon transfer tank.

REFERENCES

The material discussed in this section is presented in detail in Technical Memoranda K and O/P.

GLT233/8

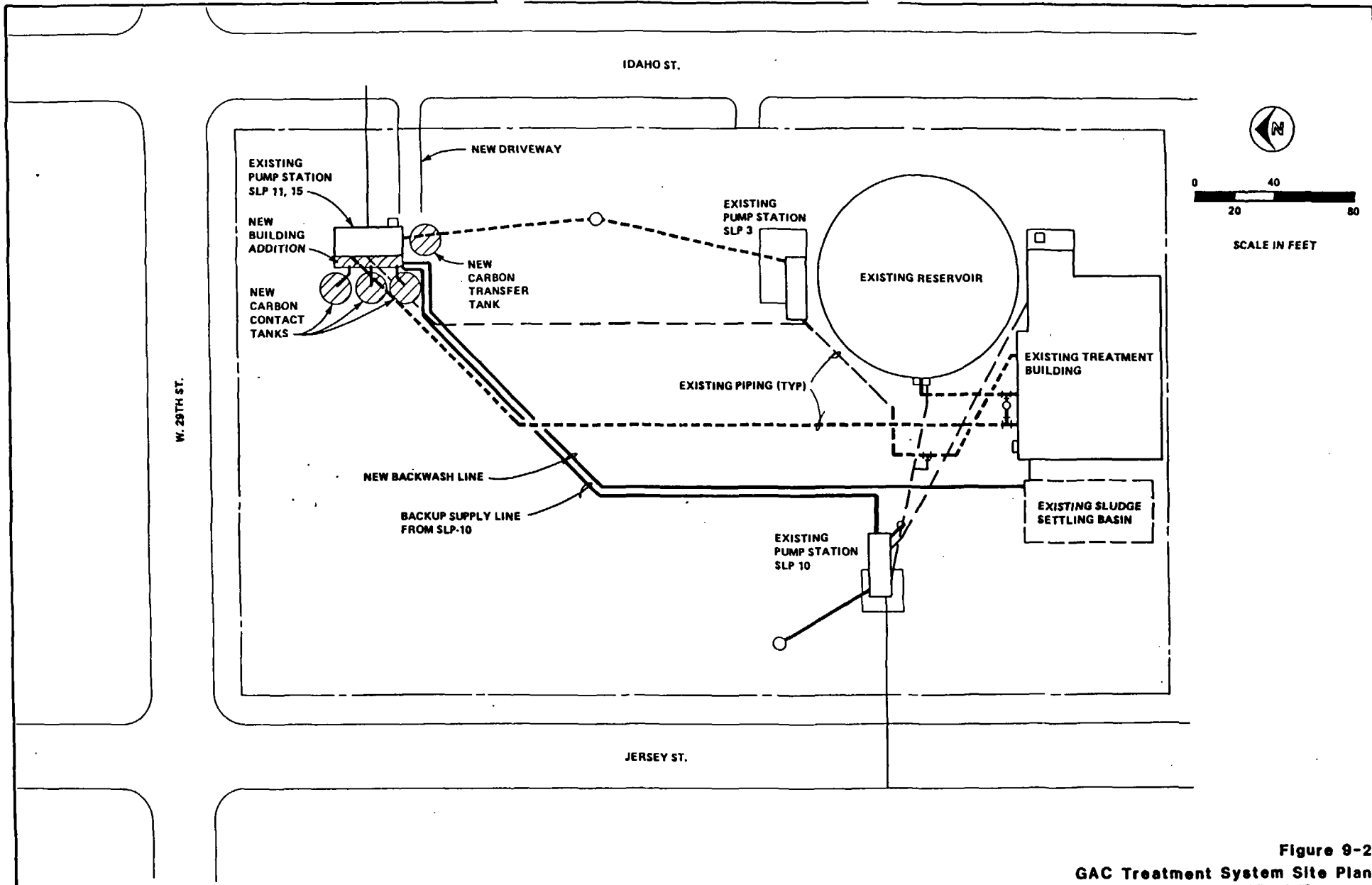

Figure 9-2
GAC Treatment System Site Plan