

Superfund

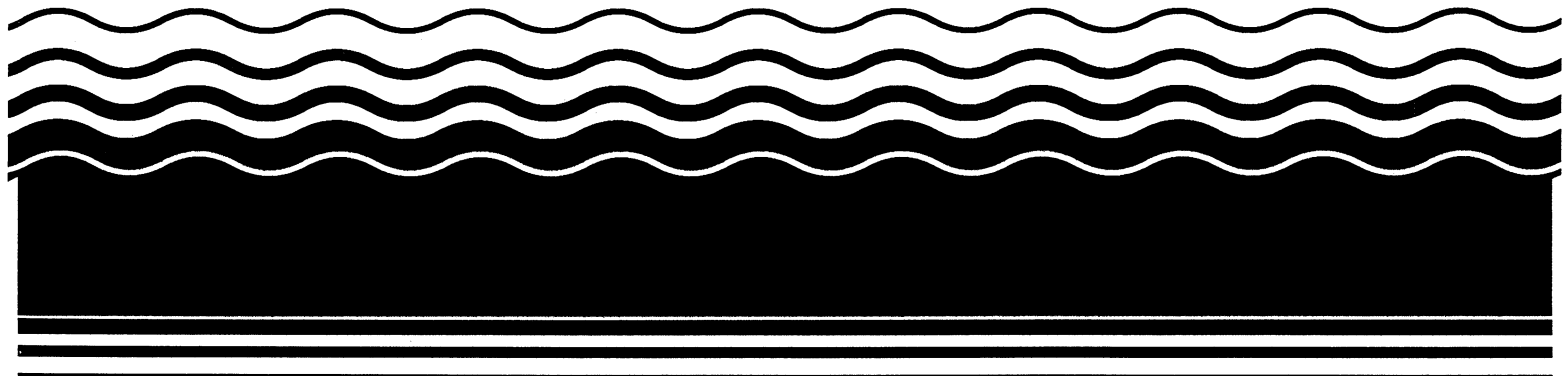

Ecological Risk Assessment Guidance for Superfund:

Process for Designing and Conducting Ecological Risk Assessments

Interim Final



**ECOLOGICAL RISK ASSESSMENT
GUIDANCE FOR SUPERFUND:
PROCESS FOR DESIGNING AND CONDUCTING
ECOLOGICAL RISK ASSESSMENTS**

INTERIM FINAL

**U.S. Environmental Protection Agency
Environmental Response Team
Edison, NJ**

June 5, 1997

DISCLAIMER

The policies and procedures set forth here are intended as guidance to Agency and other government employees. They do not constitute rulemaking by the Agency, and may not be relied on to create a substantive or procedural right enforceable by any other person. The Government may take action that is at variance with the policies and procedures in this manual.

ACKNOWLEDGEMENTS

The authors wish to acknowledge all the reviewers that have assisted the authors with insightful comments and assistance. We also wish to acknowledge the assistance of the Response Engineering and Analytic Contract Task Leader, Mark Huston and the editorial assistance of the ICF Consulting Group, primary editor Dr. Margaret McVey and Charles Chappell and Kimberly Osborn.

Mark D. Sprenger, Ph.D.
Environmental Response Team Center
Office of Emergency & Remedial Response

David W. Charters, Ph.D.
Environmental Response Team Center
Office of Emergency & Remedial Response

Primary Reviewers:

Region I Susan Svirsky
Patti Tyler

Region VI Susan Roddy
Jon Rauscher, Ph.D.

Region II Shari Stevens

Region VII Steve Wharton
Robert Koke

Region III Barbara O'Korn Root
Robert Davis

Region VIII Gerry Henningsen, Ph.D., D.V.M.
Dale Hoff, Ph.D.
Mark Wickstrom, D.V.M.

Region IV Lynn Wellman

Region IX Clarence Callahan, Ph.D.
Ned Black, Ph.D.

Region V Brenda Jones
James Chapman, Ph.D.

Region X P. Bruce Duncan, Ph.D.
Julius Nwosu
Joe Goulet, Ph.D.

Headquarters: Steve Ells

State of Texas: Larry Champagne

U.S. Fish & Wildlife Service: Nancy Finley

Peer Review Committee:

David Anderson, Ecology & Environment, Taylor, MI
John Bascietto, DOE
Tom Campbell, Woodward Clyde, Denver, CO
Cherri Bassinger-Daniel, State of MO, Department of Health

Tom Dillon, U.S. Corps of Engineers
Alyce Fritz, NOAA
Duncan Gilroy, State of Oregon DEQ, Portland, OR
Joe Greene, U.S. EPA
Mark Harkins, Science & Space Technical Committee, Washington, DC
Chris Ingersoll, U.S. DOI/NBS, Columbia, MO
Mark Johnson, U.S. Army, Aberdeen, MD
Lawrence Kapustka, EPT, Seattle, WA
Alan McIntosh, University of Vermont
Gary Mangels, American Cyanamid
Mary Matta, NOAA
Jennifer Roberts, DOEC, State of Alaska, Department of Environmental Conservation
Glen W. Suter, II, Martin Marietta Energy Systems, Inc., Oak Ridge National
Laboratory
Randy Wentsel, U.S. Army
Janet Whaley, U.S. Army, Aberdeen, MD

Stakeholder Meeting Attendees:

Jeff Foran, Meeting Facilitator
Judith Bland, Merck
Jim Clark, Exxon Biomedical Sciences
David Cragin, Elf Atochem
Steve Geiger, Remediation Technology
Simeon Hahn, U.S. Navy
David Hohreiter, Blasland, Bouck, and Lee
Kenneth Jenkins, consultant (Jenkins, Sanders, & Associates) representing General
Electric
Lorraine Keller, Rohm and Haas
Bryce Landenberger, Dow Chemical
Dale Marino, Eastman Kodak
Ellen Mihaich, Rhone-Poulenc
Ron Porter, U.S. Air Force
Mark Powell, Center for Risk Management at Resources for the Future
Lee Salamone, Chemical Manufacturers Association
Anne Sergeant, U.S. EPA
Jean Snider, NOAA
Ralph Stahl, DuPont
Randy Wentsel, U.S. Army

Observers at the Stakeholder Meeting:

Adam Ayers, Geraghty and Miller
Steve Ells, U.S. EPA

Paul Hirsh, Chemical Manufacturers Association
Teresa Larson, National Association of Manufacturers
Reo Menning, American Industrial Health Council
Kevin Reinert, Rohm and Haas
Phil Sandine, Environmental Liability Management
Wendy Sherman, Chemical Manufacturers Association
Todd Slater, Elf Atochem

CONTENTS

DISCLAIMER	i
ACKNOWLEDGEMENTS	iii
LISTS OF EXHIBITS, EXAMPLES, AND HIGHLIGHTS	xi
LIST OF ACRONYMS AND ABBREVIATIONS	xiii
PREFACE	xv
INTRODUCTION: ECOLOGICAL RISK ASSESSMENT FOR SUPERFUND	I-1
PURPOSE	I-1
SCOPE	I-1
BACKGROUND	I-1
DEFINITION OF ECOLOGICAL RISK ASSESSMENT	I-3
THE ECOLOGICAL RISK ASSESSMENT PROCESS	I-3
STEP 1: SCREENING-LEVEL PROBLEM FORMULATION AND ECOLOGICAL EFFECTS EVALUATION	1-1
1.1 INTRODUCTION	1-1
1.2 SCREENING-LEVEL PROBLEM FORMULATION	1-1
1.2.1 Environmental Setting and Contaminants at the Site	1-2
1.2.2 Contaminant Fate and Transport	1-4
1.2.3 Ecotoxicity and Potential Receptors	1-4
1.2.4 Complete Exposure Pathways	1-5
1.2.5 Assessment and Measurement Endpoints	1-7
1.3 SCREENING-LEVEL ECOLOGICAL EFFECTS EVALUATION	1-8
1.3.1 Preferred Toxicity Data	1-9
1.3.2 Dose Conversions	1-12
1.3.3 Uncertainty Assessment	1-12
1.4 SUMMARY	1-12
STEP 2: SCREENING-LEVEL EXPOSURE ESTIMATE AND RISK CALCULATION	2-1
2.1 INTRODUCTION	2-1
2.2 SCREENING-LEVEL EXPOSURE ESTIMATES	2-1
2.2.1 Exposure Parameters	2-2
2.2.2 Uncertainty Assessment	2-3
2.3 SCREENING-LEVEL RISK CALCULATION	2-4
2.4 SCIENTIFIC/MANAGEMENT DECISION POINT (SMDP)	2-5
2.5 SUMMARY	2-6

STEP 3: BASELINE RISK ASSESSMENT PROBLEM FORMULATION	3-1
3.1 THE PROBLEM-FORMULATION PROCESS	3-1
3.2 REFINEMENT OF PRELIMINARY CONTAMINANTS OF CONCERN	3-3
3.3 LITERATURE SEARCH ON KNOWN ECOLOGICAL EFFECTS	3-4
3.4 CONTAMINANT FATE AND TRANSPORT, ECOSYSTEMS POTENTIALLY AT RISK, AND COMPLETE EXPOSURE PATHWAYS	3-4
3.4.1 Contaminant Fate and Transport	3-5
3.4.2 Ecosystems Potentially at Risk	3-6
3.4.3 Complete Exposure Pathways	3-7
3.5 SELECTION OF ASSESSMENT ENDPOINTS	3-8
3.6 THE CONCEPTUAL MODEL AND RISK QUESTIONS	3-10
3.6.1 Conceptual Model	3-10
3.6.2 Risk Questions	3-14
3.7 SCIENTIFIC/MANAGEMENT DECISION POINT (SMDP)	3-15
3.8 SUMMARY	3-15
 STEP 4: STUDY DESIGN AND DATA QUALITY OBJECTIVE PROCESS	 4-1
4.1 ESTABLISHING MEASUREMENT ENDPOINTS	4-2
4.1.1 Species/Community/Habitat Considerations	4-5
4.1.2 Relationship of the Measurement Endpoints to the Contaminant of Concern	4-5
4.1.3 Mechanisms of Ecotoxicity	4-7
4.2 STUDY DESIGN	4-7
4.2.1 Bioaccumulation and Field Tissue Residue Studies	4-8
4.2.2 Population/Community Evaluations	4-12
4.2.3 Toxicity Testing	4-13
4.3 DATA QUALITY OBJECTIVES AND STATISTICAL CONSIDERATIONS	4-14
4.3.1 Data Quality Objectives	4-14
4.3.2 Statistical Considerations	4-15
4.4 CONTENTS OF WORK PLAN AND SAMPLING AND ANALYSIS PLAN	4-15
4.4.1 Work Plan	4-16
4.4.2 Sampling and Analysis Plan	4-16
4.4.3 Field Verification of Sampling Plan and Contingency Plans	4-18
4.5 SCIENTIFIC/MANAGEMENT DECISION POINT (SMDP)	4-18
4.6 SUMMARY	4-18
 STEP 5: FIELD VERIFICATION OF SAMPLING DESIGN	 5-1
5.1 PURPOSE	5-1
5.2 DETERMINING SAMPLING FEASIBILITY	5-2
5.3 SCIENTIFIC/MANAGEMENT DECISION POINT (SMDP)	5-3

5.4	SUMMARY	5-4
STEP 6:	SITE INVESTIGATION	6-1
6.1	INTRODUCTION	6-1
6.2	SITE INVESTIGATION	6-1
	6.2.1 Changing Field Conditions	6-2
	6.2.2 Unexpected Nature or Extent of Contamination	6-2
6.3	ANALYSIS OF ECOLOGICAL EXPOSURES AND EFFECTS	6-3
	6.3.1 Characterizing Exposures	6-3
	6.3.2 Characterizing Ecological Effects	6-5
6.4	SCIENTIFIC/MANAGEMENT DECISION POINT (SMDP)	6-6
6.5	SUMMARY	6-7
STEP 7:	RISK CHARACTERIZATION	7-1
7.1	INTRODUCTION	7-1
7.2	RISK ESTIMATION	7-1
7.3	RISK DESCRIPTION	7-4
	7.3.1 Threshold for Effects on Assessment Endpoints	7-4
	7.3.2 Likelihood of Risk	7-5
	7.3.3 Additional Risk Information	7-5
7.4	UNCERTAINTY ANALYSIS	7-5
	7.4.1 Categories of Uncertainty	7-6
	7.4.2 Tracking Uncertainties	7-7
7.5	SUMMARY	7-7
STEP 8:	RISK MANAGEMENT	8-1
8.1	INTRODUCTION	8-1
8.2	ECOLOGICAL RISK MANAGEMENT IN SUPERFUND	8-1
	8.2.1 Other Risk Management Considerations	8-2
	8.2.2 Ecological Impacts of Remedial Options	8-3
	8.2.3 Monitoring	8-3
8.3	SCIENTIFIC/MANAGEMENT DECISION POINT (SMDP)	8-4
8.4	SUMMARY	8-4
BIBLIOGRAPHY		Bibliography-1
GLOSSARY		Glossary-1
APPENDIX A: EXAMPLE ECOLOGICAL RISK ASSESSMENTS FOR HYPOTHETICAL SITES		
Example 1:	Copper Site	A-1
Example 2:	Stream DDT Site	A-8
Example 3:	PCB Site	A-14

**APPENDIX B: REPRESENTATIVE SAMPLING GUIDANCE DOCUMENT,
VOLUME 3: ECOLOGICAL, DRAFT**

U.S. Environmental Protection Agency (U.S. EPA). 1997. *Representative Sampling Guidance Document, Volume 3: Ecological, Draft*. Edison, NJ: Environmental Response Team, Office of Emergency and Remedial Response.

APPENDIX C: SUPPLEMENTAL GUIDANCE ON LITERATURE SEARCH

APPENDIX D: STATISTICAL CONSIDERATIONS

LISTS OF EXHIBITS, EXAMPLES, AND HIGHLIGHTS

List of Exhibits

EXHIBIT I-1: Ecological Risk Assessment Framework	I-5
EXHIBIT I-2: Eight-step Ecological Risk Assessment Process for Superfund	I-9
EXHIBIT I-3: Steps in the Ecological Risk Assessment Process and Corresponding Decision Points in the Superfund Process	I-10
EXHIBIT I-4: Ecological Risk Assessment Deliverables for the Risk Manager	I-11
EXHIBIT I-5: Ecological Risk Assessment in the Remedial Investigation/Feasibility Study (RI/FS) Process	I-13
EXHIBIT 1-1: List of Sensitive Environments in the Hazard Ranking System	1-6
EXHIBIT 6-1: Analysis Phase	6-4
EXHIBIT 7-1: Risk Characterization	7-2
EXHIBIT A-1: Conceptual Model for the Copper Site	A-5
EXHIBIT A-2: Conceptual Model for the Stream DDT Site	A-11
EXHIBIT A-3: Conceptual Model for the Terrestrial PCB Site	A-17

List of Examples

EXAMPLE 1-1: Ecotoxicity-PCB Site	1-5
EXAMPLE 1-2: Complete Exposure Pathways for Mammals-PCB Site	1-8
EXAMPLE 3-1: Exposure Pathway Model-DDT Site	3-7
EXAMPLE 3-2: Potential for Food Chain Transfer-Copper and DDT Sites	3-8
EXAMPLE 3-3: Assessment Endpoint Selection-DDT, Copper, and PCB Sites	3-11
EXAMPLE 3-4: Description of the Conceptual Model-DDT Site	3-12
EXAMPLE 3-5: Conceptual Model Diagram-DDT Site	3-13
EXAMPLE 4-1: Lines of Evidence-Copper Site	4-4
EXAMPLE 4-2: Selecting Measurement Endpoints-DDT Site	4-6
EXAMPLE 4-3: Tissue Residue Studies-DDT Site	4-9
EXAMPLE 5-1: Field Verification of Sampling Design-Copper Site	5-4
EXAMPLE 5-2: Field Verification of Sampling Design-DDT Site	5-5
EXAMPLE 6-1: Fish Sampling Contingency Plan-DDT Site	6-2

List of Highlights

HIGHLIGHT I-1: The RI/FS Process	I-2
HIGHLIGHT I-2: Example Assessment Endpoints	I-6
HIGHLIGHT I-3: Example Measurement Endpoints	I-6
HIGHLIGHT I-4: Ecological Impact and Risk Assessment	I-8
HIGHLIGHT 1-1: Screening-level Risk Assessments	1-2
HIGHLIGHT 1-2: Industrial or Urban Settings	1-4
HIGHLIGHT 1-3: Exposure Pathway and Exposure Route	1-7
HIGHLIGHT 1-4: Non-Chemical Stressors	1-9
HIGHLIGHT 1-5: Data Hierarchy for Deriving Screening Ecotoxicity Values	1-10
HIGHLIGHT 1-6: NOAEL Preferred to LOAEL	1-11
HIGHLIGHT 2-1: Area Use Factor	2-2
HIGHLIGHT 2-2: Hazard Index (HI) Calculation	2-5
HIGHLIGHT 3-1: Tiering an Ecological Risk Assessment	3-3
HIGHLIGHT 3-2: Environmental Fate and Exposure	3-5
HIGHLIGHT 3-3: Definitions: Null and Test Hypotheses	3-14
HIGHLIGHT 4-1: Importance of Distinguishing Measurement from Assessment Endpoints	4-3
HIGHLIGHT 4-2: Terminology and Definitions	4-6
HIGHLIGHT 4-3: Elements of a QAPP	4-17
HIGHLIGHT 6-1: Uncertainty in Exposure Models	6-5

LIST OF ACRONYMS AND ABBREVIATIONS

AQUIRE:	U.S. EPA's AQUatic Information REtrieval database
ARAR:	Applicable or Relevant and Appropriate Requirements
ASTM:	American Society of Testing and Materials
BAF:	Bioaccumulation Factor
BCF:	Bioconcentration Factor
BIOSIS:	Biosciences Information Services
BTAG:	Biological Technical Assistance Group
CERCLA:	Comprehensive Environmental Response, Compensation, and Liability Act
CLP:	Contract Laboratory Program
DDT:	Dichlorodiphenyltrichloroethane
DQO:	Data Quality Objective
EC ₅₀ :	Effective Concentration for producing a specified effect in 50 percent of the test organisms
EEC:	Estimated Environmental Concentration
EPA:	Environmental Protection Agency
FS:	Feasibility Study
FSP:	Field Sampling Plan
FWS:	Fish and Wildlife Service
HEAST:	National Center for Environmental Assessment's Health Effects Assessment Summary Tables
HI:	Hazard Index
HQ:	Hazard Quotient
HSDB:	National Library of Medicine's Hazardous Substances Data Bank
IRIS:	EPA's Integrated Risk Information System
LC ₅₀ :	Concentration Lethal to 50 percent of the test organisms
Li	Liter
LOAEL:	Lowest-Observed-Adverse-Effect Level
NCP:	National Oil and Hazardous Substances Pollution Contingency Plan
NOAA:	National Oceanic and Atmospheric Administration
NOAEL:	No-Observed-Adverse-Effect Level
NRC:	National Research Council
NRDA:	Natural Resource Damage Assessment
OERR:	U.S. EPA Office of Emergency and Remedial Response
OSC:	On-Scene Coordinator
OSWER:	U.S. EPA Office of Solid Waste and Emergency Response
PA	Preliminary Assessment
PAH:	Polycyclic Aromatic Hydrocarbons
PCB:	Polychlorinated Biphenyl compound
PRP:	Potentially Responsible Party
QAPP:	Quality Assurance Project Plan
QA/QC:	Quality Assurance and Quality Control

RBP: Rapid Bioassessment Protocol
RI: Remedial Investigation
ROD: Record of Decision
RPM: Remedial Project Manager
SAP: Sampling and Analysis Plan
SARA: Superfund Amendments and Reauthorization Act of 1986
SI: Site Investigation
SMDP: Scientific/Management Decision Point
TOC: Total Organic Carbon
WP: Work Plan

PREFACE

This document provides guidance on the process of designing and conducting technically defensible ecological risk assessments for the Superfund Program. It is intended to promote consistency and a science-based approach within the Program and is based on the *Proposed Guidelines for Ecological Risk Assessment* (1996a) and the *Framework for Ecological Risk Assessment* (1992a) developed by the Risk Assessment Forum of the U.S. Environmental Protection Agency. When the Agency publishes its final *Guidelines for Ecological Risk Assessment*, this guidance will be reviewed and revised if necessary to ensure consistency with the Agency guidelines.

This document is directed to the site managers (i.e., On-Scene Coordinators [OSCs] and Remedial Project Managers [RPMs]) who are legally responsible for the management of a site. However, it is anticipated that ecological risk assessors, as well as other individuals with input to the ecological risk assessment, will use this document.

Ecological risk assessment is an integral part of the Remedial Investigation and Feasibility Study (RI/FS) process, which is designed to support risk management decision-making for Superfund sites. The RI component of the process characterizes the nature and extent of contamination at a hazardous waste site and estimates risks to human health and the environment posed by contaminants at the site. The FS component of the process develops and evaluates remedial options. Thus, ecological risk assessment is fundamental to the RI and ecological considerations are also part of the FS process.

This document is intended to facilitate defensible site-specific ecological risk assessments. It is not intended to determine the appropriate scale or complexity of an ecological risk assessment or to direct the user in the selection of specific protocols or investigation methods. Professional judgment is essential in designing and determining the data needs for any ecological risk assessment. However, when the process outlined in this document is followed, a technically defensible and appropriately scaled site-specific ecological risk assessment should result.

Ecological risk assessment is an interdisciplinary field drawing upon environmental toxicology, ecology, and environmental chemistry, as well as other areas of science and mathematics. It is important that users of this document understand that ecological risk assessment is a complex, non-linear process, with many parallel activities. The user should have a basic understanding of ecotoxicology and ecological risk assessment and read through this document in its entirety prior to engaging in the ecological risk assessment process. Without the basic understanding of the field and of this guidance, the reader might not recognize the relationships among different components of the risk assessment process.

To assist the user in interpreting this guidance document, three illustrations of planning an ecological risk assessment for a hazardous waste site are provided in

Appendix A. These are simplified, hypothetical examples that demonstrate and highlight specific points in the ecological risk assessment process. These examples are incomplete and not intended to present a thorough discussion of the ecological or ecotoxicological issues that would exist at an actual site. Instead, they are intended to illustrate the first five steps of the process, which precede a full ecological field investigation. Excerpts from the three examples are included in the guidance document as "Example" boxes to illustrate specific points. The user is encouraged to read the three examples in Appendix A in addition to the Example boxes within the guidance document itself.

Ecological risk assessment is a dynamic field, and this document represents a process framework into which changes in ecological risk assessment approaches can readily be incorporated. Four appendices are included with this document; additional appendices may be developed to address specific issues.

This document supersedes the U.S. EPA's (1989b) *Risk Assessment Guidance for Superfund, Volume 2: Environmental Evaluation Manual* as guidance on how to design and conduct an ecological risk assessment for the Superfund Program. The *Environmental Evaluation Manual* contains useful information on the statutory and regulatory basis of ecological assessment, basic ecological concepts, and other background information that is not repeated in this document.

INTRODUCTION: ECOLOGICAL RISK ASSESSMENT FOR SUPERFUND

PURPOSE

This document provides guidance on how to design and conduct consistent and technically defensible ecological risk assessments for the Superfund Program. It is based on the *Proposed Guidelines for Ecological Risk Assessment* (1996a) and the *Framework for Ecological Risk Assessment* (1992a) developed by the Risk Assessment Forum of the U.S. Environmental Protection Agency (U.S. EPA or the Agency). When the Agency finalizes its (1996a) *Proposed Guidelines for Ecological Risk Assessment*, this guidance will be reviewed and revised if necessary to ensure consistency with the Agency guidelines.

This document is directed to the site managers (i.e., On-Scene Coordinators [OSCs] and Remedial Project Managers [RPMs]) who are legally responsible for managing site activities. However, it is anticipated that the ecological risk assessors, as well as all other individuals involved with ecological risk assessments, will use this document.

SCOPE

This document is intended to facilitate defensible and appropriately-scaled site-specific ecological risk assessments. It is not intended to dictate the scale, complexity, protocols, data needs, or investigation methods for such assessments. Professional judgment is required to apply the process outlined in this document to ecological risk assessments at specific sites.

BACKGROUND

Superfund Program

The Comprehensive Environmental Response, Compensation, and Liability Act of 1980 (CERCLA or Superfund), as amended by the Superfund Amendments and Reauthorization Act of 1986 (SARA), authorizes the U.S. EPA to protect public health and welfare and the environment from the release or potential release of any hazardous substance, pollutant, or contaminant. U.S. EPA's Superfund Program carries out the Agency's mandate under CERCLA/SARA.

The primary regulation issued by U.S. EPA's Superfund Program is the National Oil and Hazardous Substances Pollution Contingency Plan (NCP). The NCP calls for the identification and mitigation of environmental impacts (such as toxicity, bioaccumulation, death, reproductive impairment, growth impairment, and loss of critical habitat) at hazardous waste sites, and for the selection of remedial actions to protect the environment. In addition,

numerous other federal and state laws and regulations concerning environmental protection can be designated under Superfund as "applicable" or "relevant and appropriate" requirements (ARARs) for particular sites. Compliance with these other laws and regulations generally requires an evaluation of site-related ecological effects and the measures necessary to mitigate those effects.

Risk Assessment in Superfund

An important part of the NCP is the requirement for a Remedial Investigation and Feasibility Study (RI/FS) (see Highlight I-1). The RI/FS is an analytical process designed to support risk management decision-making for Superfund sites. The RI component of the process characterizes the nature and extent of contamination at a hazardous waste site and estimates risks to human health and the environment posed by contaminants at the site. The FS component of the process develops and evaluates remedial options.

Although U.S. EPA has established detailed guidelines for human health risk assessment in the Superfund program (U.S. EPA, 1989a, 1991a,b), similarly detailed guidelines for site-specific ecological risk assessment do not exist for the Superfund program. *Risk Assessment Guidance for Superfund, Volume 2: Environmental Evaluation Manual* (U.S. EPA, 1989b) provides conceptual guidance in planning studies to evaluate a hazardous waste site's "environmental resources" (as used in the manual, the phrase "environmental resources" is largely synonymous with "ecological resources"). U.S. EPA also is publishing supplemental information on specific ecological risk assessment topics for Superfund in the *ECO Update* series (U.S. EPA, 1995b, 1994b,c,d,e, 1992b,c,d, 1991c,d). However, those documents do not describe an overall, step-by-step process by which an ecological risk assessment is designed and executed. The Agency's *Framework for Ecological Risk Assessment* (U.S. EPA, 1992a) provides a basic structure and a consistent approach for conducting ecological risk assessments, but is not intended to provide program-specific guidance. The *Guidelines for Ecological Risk Assessment*, currently being developed by the Agency's Risk Assessment Forum (1996a), will expand on the *Framework*, but again, will not provide program-specific guidance.

This document outlines a step-by-step ecological risk assessment process that is both specific to the Superfund Program and consistent with the more general U.S. EPA *Framework* and guidelines under development. While the Agency's *Framework* and future Agency-wide ecological risk assessment guidelines are not enforceable regulations, the concepts in those

HIGHLIGHT I-1 The RI/FS Process

Risk assessment is an integral part of the RI/FS. The three parts of the RI are: (1) characterization of the nature and extent of contamination; (2) ecological risk assessment; and (3) human health risk assessment. The investigation of the nature and extent of contamination determines the chemicals present on site as well as their distribution and concentrations. The ecological risk and human health risk assessments determine the potential for adverse effects to the environment and human health, respectively.

documents are appropriate to Superfund. The concepts in the published *Framework* have been incorporated into this document with minimal modification. The definitions of terms used in this ecological risk assessment guidance for Superfund (and listed in the Glossary) are consistent with the definitions in the U.S. EPA *Framework* document unless noted otherwise.

DEFINITION OF ECOLOGICAL RISK ASSESSMENT

U.S. EPA "Framework" Document

Ecological risk assessment is defined in the *Framework* as a process that evaluates the likelihood that adverse ecological effects are occurring or may occur as a result of exposure to one or more stressors (U.S. EPA, 1992a). The *Framework* defines a stressor as any physical, chemical, or biological entity that can induce an adverse ecological response. Adverse responses can range from sublethal chronic effects in individual organisms to a loss of ecosystem function. Although stressors can be biological (e.g., introduced species), only chemical or physical stressors will be addressed in this document, because these are the stressors subject to risk management decisions at Superfund sites.

Superfund Program

The phrase "ecological risk assessment," as used specifically for the Superfund Program in this document, refers to a qualitative and/or quantitative appraisal of the actual or potential impacts of contaminants from a hazardous waste site on plants and animals other than humans and domesticated species. A risk does not exist unless: (1) the stressor has the ability to cause one or more adverse effects, and (2) it co-occurs with or contacts an ecological component long enough and at a sufficient intensity to elicit the identified adverse effect.

THE ECOLOGICAL RISK ASSESSMENT PROCESS

U.S. EPA "Framework" Document

The *Framework* describes the basic elements of a process for scientifically evaluating the adverse effects of stressors on ecosystems and components of ecosystems. The document describes the basic process and principles to be used in ecological risk assessments conducted for the U.S. EPA, provides operational definitions for terms used in ecological risk assessments, and outlines basic principles around which program-specific guidelines for ecological risk assessment should be organized.

The *Framework* is similar to the National Research Council's (NRC) paradigm for human health risk assessments (NRC, 1983) and the more recent NRC ecological risk paradigm (NRC, 1993). The 1983 NRC paradigm consists of four fundamental phases:

hazard identification, dose-response assessment, exposure assessment, and risk characterization. The *Framework* differs from the 1983 NRC paradigm in a few ways:

- Problem formulation is incorporated into the beginning of the process to determine the focus and scope of the assessment;
- Hazard identification and dose-response assessment are combined in an ecological effects assessment phase; and
- The phrase "dose-response" is replaced by "stressor-response" to emphasize the possibility that physical changes (which are not measured in "doses") as well as chemical contamination can stress ecosystems.

Moreover, the *Framework* emphasizes the parallel nature of the ecological effects and exposure assessments by joining the two assessments in an analysis phase between problem formulation and risk characterization, as shown in Exhibit I-1.

During problem formulation, the risk assessor establishes the goals, breadth, and focus of the assessment (U.S. EPA, 1992a). As indicated in the *Framework*, problem formulation is a systematic planning step that identifies the major factors to be considered and is linked to the regulatory and policy contexts of the assessment. Problem formulation includes discussions between the risk assessor and risk manager, and other involved parties, to identify the stressor characteristics, ecosystems potentially at risk, and ecological effects to be evaluated. During problem formulation, assessment and measurement endpoints for the ecological risk assessment are identified, as described below.

The Agency defines assessment endpoints as explicit expressions of the actual environmental values (e.g., ecological resources) that are to be protected (U.S. EPA, 1992a). Valuable ecological resources include those without which ecosystem function would be significantly impaired, those providing critical resources (e.g., habitat, fisheries), and those perceived as valuable by humans (e.g., endangered species and other issues addressed by legislation). Because assessment endpoints focus the risk assessment design and analysis, appropriate selection and definition of these endpoints are critical to the utility of a risk assessment.

Assessment endpoints should relate to statutory mandates (e.g., protection of the environment), but must be specific enough to guide the development of the risk assessment study design at a particular site. Useful assessment endpoints define both the valued ecological entity at the site (e.g., a species, ecological resource, or habitat type) and a characteristic(s) of the entity to protect (e.g., reproductive success, production per unit area, areal extent). Highlight I-2 provides some examples of specific assessment endpoints related to the general goal of protecting aquatic ecosystems.

EXHIBIT I-1
Ecological Risk Assessment Framework (U.S. EPA, 1992a)

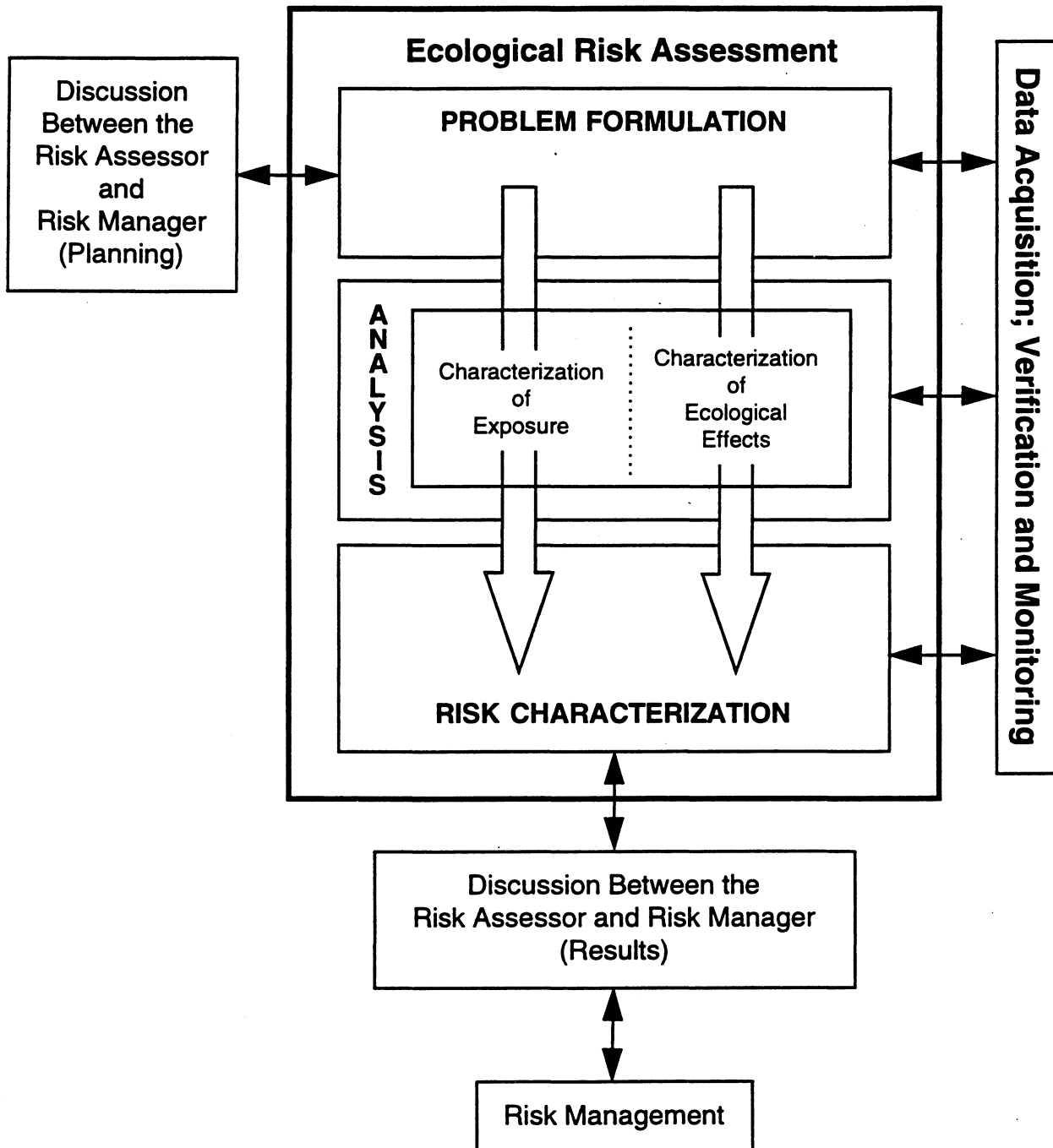

A measurement endpoint is a measurable biological response to a stressor that can be related to the valued characteristic chosen as the assessment endpoint (U.S. EPA, 1992a; although this definition may change—see U.S. EPA, 1996a). Sometimes, the assessment endpoint can be measured directly; usually, however, an assessment endpoint encompasses too many species or species that are difficult to evaluate (e.g., top-level predators). In these cases, the measurement endpoints are different from the assessment endpoint, but can be used to make inferences about risks to the assessment endpoints. For example, measures of responses in particularly sensitive species and life stages might be used to infer responses in the remaining species and life stages in a specific community. Such inferences must be clearly described to demonstrate the link between measurement and assessment endpoints. Highlight I-3 provides examples of measurement endpoints.

HIGHLIGHT I-2
Example Assessment Endpoints

- Sustained aquatic community structure, including species composition and relative abundance and trophic structure.
- Sufficient rates of survival, growth, and reproduction to sustain populations of carnivores typical for the area.
- Sustained fishery diversity and abundance.

Measures of exposure also can be used to make inferences about risks to assessment endpoints at Superfund sites. For example, measures of water concentrations of a contaminant can be compared with concentrations known from the literature to be lethal to sensitive aquatic organisms to infer something about risks to aquatic community structure. As a consequence, for purposes of this guidance, measurement endpoints include both measures of effect and measures of exposure.

A product of problem formulation is a conceptual model for the ecological risk assessment that describes how a given stressor might affect ecological components of the environment. The conceptual model also describes questions about how stressors affect the assessment endpoints, the relationships among the assessment and measurement endpoints, the data required to answer the questions, and the methods that will be used to analyze the data (U.S. EPA, 1992a).

HIGHLIGHT I-3
Example Measurement Endpoints

- Community analysis of benthic macroinvertebrates.
- Survival and growth of fish fry in response to exposure to copper.
- Community structure of fishery in proximity to the site.

Superfund Program

The goal of the ecological risk assessment process in the Superfund Program is to provide the risk information necessary to assist risk managers at Superfund sites (OSCs and RPMs) in making informed decisions regarding substances designated as hazardous under CERCLA (see 40 CFR 302.4). The specific objectives of the process, as stated in OSWER Directive 9285.7-17, are: (1) to identify and characterize the current and potential threats to the environment from a hazardous substance release; and (2) to identify cleanup levels that would protect those natural resources from risk. Threats to the environment include existing adverse ecological impacts and the risk of such impacts in the future. Highlight I-4 provides an overview of ecological risk assessment in the Superfund Program.

Problem formulation is the most critical step of an ecological risk assessment and must precede any attempt to design a site investigation and analysis plan. To ensure that the risk manager can use the results of an ecological risk assessment to inform risk management decisions for a Superfund site, it is important that all involved parties contribute to the problem formulation phase and that the risk manager is clearly identified to all parties. These parties include the remedial project manager (RPM), who is the risk manager with ultimate responsibility for the site, the ecological risk assessment team, the Regional Superfund Biological Technical Assistance Group (BTAG), potentially responsible parties (PRPs), Natural Resource Trustees, and stakeholders in the natural resources at issue (e.g., local communities, state agencies) (U.S. EPA, 1994a, 1995b). The U.S. EPA's (1994a) *Edgewater Consensus on an EPA Strategy for Ecosystem Protection* in particular calls for the Agency to develop a "place-driven" orientation, that is, to focus on the environmental needs of specific communities and ecosystems, rather than on piecemeal program mandates. Participation in problem formulation by all involved parties helps to achieve the place-driven focus.

Issues such as restoration, mitigation, and replacement are important to the Superfund Program, but are reserved for investigations that might or might not be included in the RI phase. During the risk management process of selecting the preferred remedial option leading to the Record of Decision (ROD), issues of mitigation and restoration should be addressed. In selecting a remedy, the risk manager must also consider the degree to which the remedial alternatives reduce risk and thereby also reduce the need for restoration or mitigation.

A natural resource damage assessment (NRDA) may be conducted at a Superfund site at the discretion of Natural Resource Trustees for specific resources associated with a site. An ecological risk assessment is a necessary step for an NRDA, because it establishes the causal link between site contaminants and specific adverse ecological effects. The risk assessment also can provide information on what residual risks are likely for different remediation options. However, the ecological risk assessment does not constitute an NRDA. The NRDA is the sole responsibility of the Natural Resource Trustees, not of the U.S. EPA; therefore, NRDA's will not be addressed in this guidance. For additional information on the role of Natural Resource Trustees in the Superfund process, see *ECO Update Volume 1, Number 3* (U.S. EPA, 1992c).

HIGHLIGHT I-4

Ecological Impact and Risk Assessment

Ecological risk assessment within the Superfund Program can be a risk evaluation (potentially predictive), impact evaluation, or a combination of those approaches. The functions of the ecological risk assessment are to:

- (1) Document whether actual or potential ecological risks exist at a site;
- (2) Identify which contaminants present at a site pose an ecological risk; and
- (3) Generate data to be used in evaluating cleanup options.

Ecological risk assessments can have their greatest influence on risk management at a site in the evaluation and selection of site remedies. The ecological risk assessment should identify contamination levels that bound a threshold for adverse effects on the assessment endpoint. The threshold values provide a yardstick for evaluating the effectiveness of remedial options and can be used to set cleanup goals if appropriate.

To justify a site action based upon ecological concerns, the ecological risk assessment must establish that an actual or potential ecological threat exists at a site. The potential for (i.e., risk of) impacts can be the threat of impacts from a future release or redistribution of contaminants, which could be avoided by taking actions on "hot spots" or source areas. Risk also can be viewed as the likelihood that current impacts are occurring (e.g., diminished population size), although this can be difficult to demonstrate. For example, it may not be practical or technically possible to document existing ecological impacts, either due to limited technique resolution, the localized nature of the actual impact, or limitations resulting from the biological or ecological constraints of the field measurements (e.g., measurement endpoints, exposure point evaluation). Actually demonstrating existing impacts confirms that a "risk" exists. Evaluating a gradient of existing impacts along a gradient of contamination can provide an stressor-response assessment that helps to identify cleanup levels.

As noted above, the ecological risk assessment should provide the information needed to make risk management decisions (e.g., to select the appropriate site remedy). A management option should not be selected first, and then the risk assessment tailored to justify the option.

This Guidance Document

This ecological risk assessment guidance for Superfund is composed of eight steps (see Exhibit I-2) and several scientific/management decision points (SMDPs) (see Exhibit I-3). An SMDP requires a meeting between the risk manager and risk assessment team to evaluate and approve or redirect the work up to that point. (Consultation with the Regional BTAG is recommended for SMDPs (a) through (d) in Exhibit I-3.) The group decides

EXHIBIT I-2
Eight-step Ecological Risk Assessment Process for Superfund

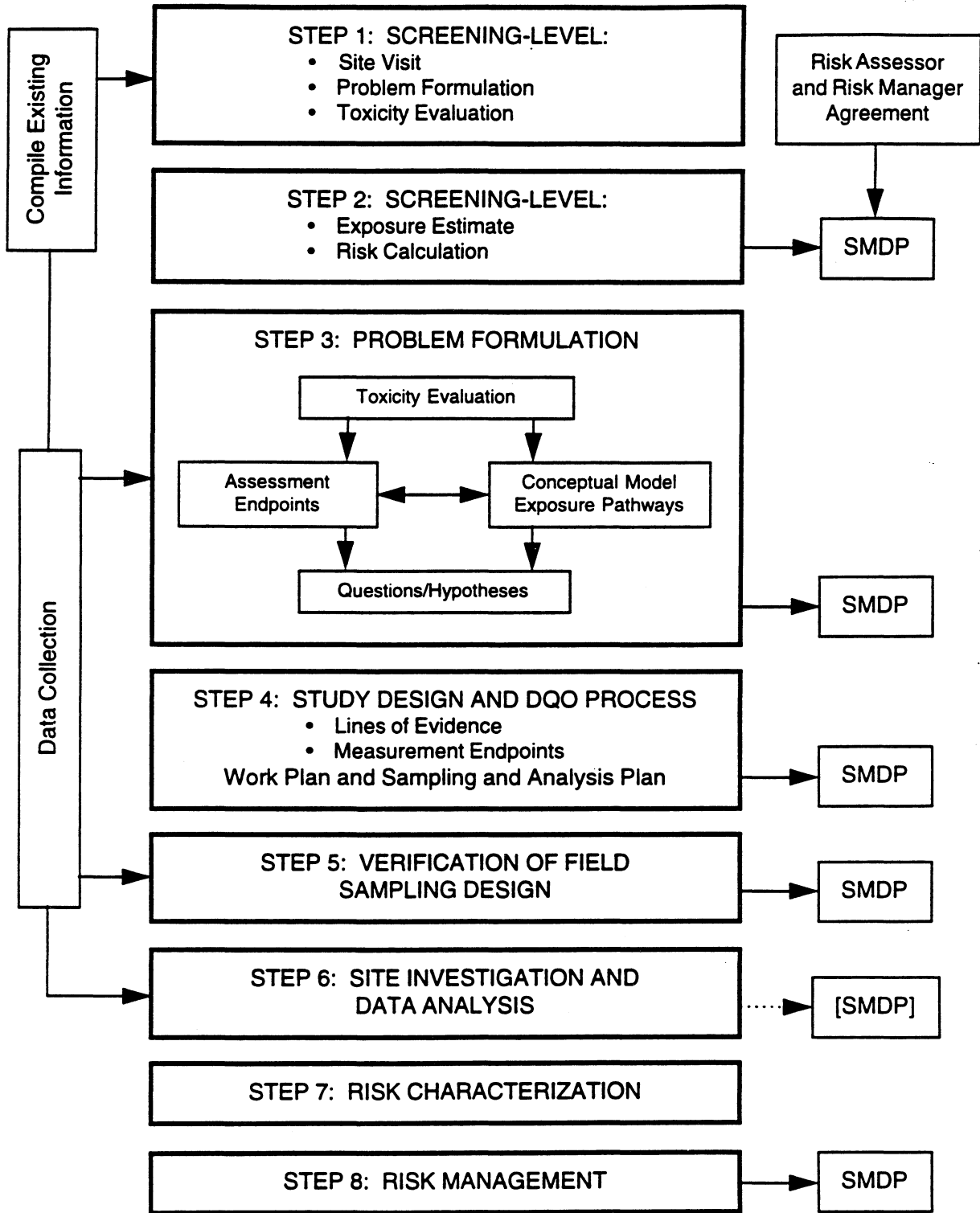

EXHIBIT I-3
Steps in the Ecological Risk Assessment Process
and Corresponding Decision Points in the Superfund Process

Steps and Scientific/Management Decision Points (SMDPs):

- | | | |
|----|---|----------|
| 1. | Screening-Level Problem Formulation and Ecological Effects Evaluation | |
| 2. | Screening-Level Preliminary Exposure Estimate and Risk Calculation | SMDP (a) |
| 3. | Baseline Risk Assessment Problem Formulation | SMDP (b) |
| 4. | Study Design and Data Quality Objectives | SMDP (c) |
| 5. | Field Verification of Sampling Design | SMDP (d) |
| 6. | Site Investigation and Analysis of Exposure and Effects | [SMDP] |
| 7. | Risk Characterization | |
| 8. | Risk Management | SMDP (e) |

Corresponding Decision Points in the Superfund Process:

- (a) Decision about whether a full ecological risk assessment is necessary.
- (b) Agreement among the risk assessors, risk manager, and other involved parties on the conceptual model, including assessment endpoints, exposure pathways, and questions or risk hypotheses.
- (c) Agreement among the risk assessors and risk manager on the measurement endpoints, study design, and data interpretation and analysis.
- (d) Signing approval of the work plan and sampling and analysis plan for the ecological risk assessment.
- (e) Signing the Record of Decision.

[SMDP] only if change to the sampling and analysis plan is necessary.

whether or not the risk assessment is proceeding in a direction that is acceptable to the risk assessors and manager. The SMDPs include a discussion of the uncertainty associated with the risk assessment, that might be reduced, if necessary, with increased effort. SMDPs are significant communication points which should be passed with the consensus of all involved parties. The risk manager should expect deliverables that document specific SMDPs as outlined in Exhibit I-4. This approach is intended to minimize both the cost of and time required for the Superfund risk assessment process.

This guidance provides a technically valid approach for ecological risk assessments at hazardous waste sites, although other approaches also can be valid. The discipline of ecological risk assessment is dynamic and continually evolving; the assessments rely on data that are complex and sometimes ambiguous. Thus, if an approach other than the one described in this guidance document is used, there must be clear documentation of the process, including process design and interpretation of the results, to ensure a technically defensible assessment. Clear documentation, consistency, and objectivity in the assessment process are necessary for the Superfund Program.

An interdisciplinary team including, but not limited to, biologists, ecologists, and environmental toxicologists, is needed to design and implement a successful risk assessment and to evaluate the weight of the evidence obtained to reach conclusions about ecological risks. Some of the many points at which the Superfund ecological risk assessment process requires professional judgment include:

EXHIBIT I-4
Ecological Risk Assessment Deliverables
for the Risk Manager

If the process stops at the end of Step 2:

- (1) Full documentation of the screening-level assessment and SMDP not to continue the assessment.

If the process continues to Step 3:

- (1) Documentation of the conceptual model, including assessment endpoints, exposure pathways, risk hypotheses, and SMDP at the end of Step 3.
- (2) The approved and signed work plan and sampling and analysis plan, documenting the SMDPs at the end of Steps 4 and 5.
- (3) The baseline risk assessment documentation (including documentation of the screening-level assessment used in the baseline assessment) developed in Step 7.

- Determining the level of effort needed to assess ecological risk at a particular site;
- Determining the relevance of available data to the risk assessment;
- Designing a conceptual model of the ecological threats at a site and measures to assess those threats;
- Selecting methods and models to be used in the various components of the risk assessment;
- Developing assumptions to fill data gaps for toxicity and exposure assessments based on logic and scientific principles; and
- Interpreting the ecological significance of observed or predicted effects.

The lead risk assessor should coordinate with appropriate professionals to make many of these decisions. Specialists are needed for the more technical questions concerning the risk assessment (e.g., which model, which assumptions).

This guidance document focuses on the risk assessment process in Superfund and does not address all of the issues that a risk manager will need to consider. After the risk assessment is complete, the risk manager might require additional professional assistance in interpreting the implications of the baseline ecological risk assessment and selecting a remedial option.

The risk assessment process must be structured to ensure that site management decisions can be made without the need for repeated studies or delays. The first two steps in the assessment process are a streamlined version of the complete *Framework* process and are intended to allow a rapid determination by the risk assessment team and risk manager that the site poses no or negligible ecological risk, or to identify which contaminants and exposure pathways require further evaluation. Steps 3 through 7 are a more detailed version of the complete *Framework* process.

The ecological risk assessment process should be coordinated with the overall RI/FS process to the extent possible. Overall site-assessment costs are minimized when the needs of the ecological and human health risk assessments are incorporated into the chemical sampling program to determine the nature and extent of contamination during the RI. For sites at which an RI has not yet been planned or conducted, Exhibit I-5 illustrates the relationship between the eight ecological risk assessment steps and the overall Superfund process and decision points. For older sites at which an RI was conducted before an ecological risk assessment was considered, the ecological risk assessment process should build on the information already developed for the site.

EXHIBIT I-5
Ecological Risk Assessment in the RI/FS Process

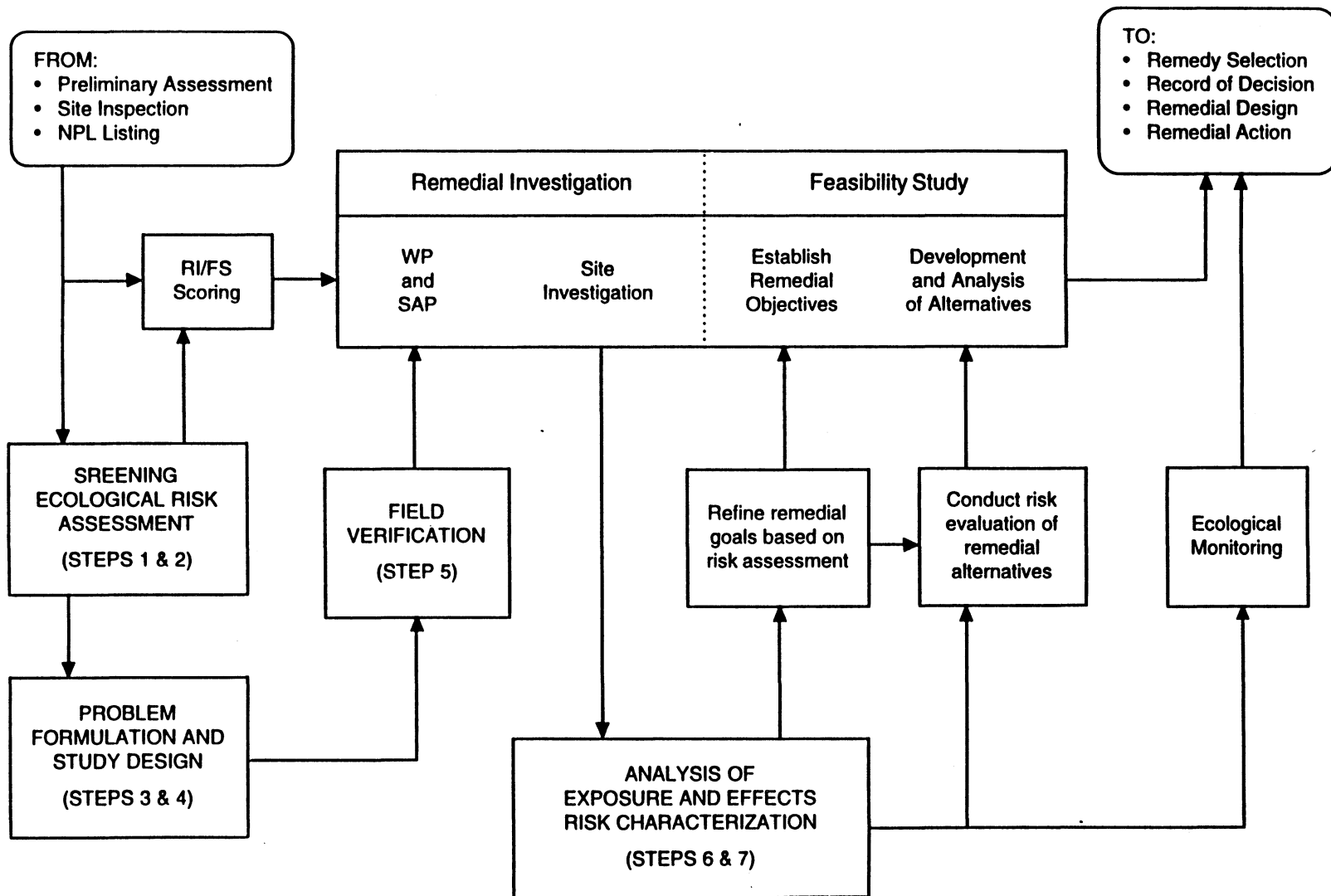

It is important to realize that this eight-step approach is not a simple linear or sequential process. The order of actions taken will depend upon the stage of the RI/FS at which the site is currently, the amount and types of site information available, as well as other factors. The process can be iterative, and in some iterations, certain individual steps might not be needed. In many cases, it might be appropriate and desirable to conduct several steps concurrently.

Tasks that should be accomplished in each of the eight steps in Exhibits I-2 and I-3 are described in the eight following sections. The eight sections include example boxes based on the three hypothetical Superfund sites in Appendix A as well as exhibits and highlight boxes.

STEP 1: SCREENING-LEVEL PROBLEM FORMULATION AND ECOLOGICAL EFFECTS EVALUATION

OVERVIEW

The screening-level problem formulation and ecological effects evaluation is part of the initial ecological risk screening assessment. For this initial step, it is likely that site-specific information for determining the nature and extent of contamination and for characterizing ecological receptors at the site is limited. This step includes all the functions of problem formulation (more fully described in Steps 3 and 4) and ecological effects analysis, but on a screening level. The results of this step will be used in conjunction with exposure estimates in the preliminary risk calculation in Step 2.

1.1 INTRODUCTION

Step 1 is the screening-level problem formulation process and ecological effects evaluation (Highlight 1-1 defines screening-level risk assessments). Consultation with the BTAG is recommended at this stage. How to brief the BTAG on the setting, history, and ecology of a site is described in *ECO Update Volume 1, Number 5* (U.S. EPA, 1992d). Section 1.2 describes the screening-level problem formulation, and Section 1.3 describes the screening-level ecological effects evaluation. Section 1.4 summarizes this step.

1.2 SCREENING-LEVEL PROBLEM FORMULATION

For the screening-level problem formulation, the risk assessor develops a conceptual model for the site that addresses five issues:

- (1) Environmental setting and contaminants known or suspected to exist at the site (Section 1.2.1);
- (2) Contaminant fate and transport mechanisms that might exist at the site (Section 1.2.2);
- (3) The mechanisms of ecotoxicity associated with contaminants and likely categories of receptors that could be affected (Section 1.2.3);

- (4) What complete exposure pathways might exist at the site (a complete exposure pathway is one in which the chemical can be traced or expected to travel from the source to a receptor that can be affected by the chemical) (Section 1.2.4); and
- (5) Selection of endpoints to screen for ecological risk (Section 1.2.5).

1.2.1 Environmental Setting and Contaminants at the Site

To begin the screening-level problem formulation, there must be at least a rudimentary knowledge of the potential environmental setting and chemical contamination at the site. The first step is to compile information from the site history and from reports related to the site, including the Preliminary Assessment (PA) or Site Investigation (SI). The second step is to use the environmental checklist presented in *Representative Sampling Guidance Document, Volume 3: Ecological* (U.S. EPA, 1997; see Appendix B) to begin characterizing the site for problem formulation. Key questions addressed by the checklist include:

- What are the on- and off-site land uses (e.g., industrial, residential, or undeveloped; current and future)?
- What type of facility existed or exists at the site?
- What are the suspected contaminants at the site?
- What is the environmental setting, including natural areas (e.g., upland forest, on-site stream, nearby wildlife refuge) as well as disturbed/man-made areas (e.g., waste lagoons)?
- Which habitats present on site are potentially contaminated or otherwise disturbed?

HIGHLIGHT 1-1 Screening-level Risk Assessments

Screening-level risk assessments are simplified risk assessments that can be conducted with limited data by assuming values for parameters for which data are lacking. At the screening level, it is important to minimize the chances of concluding that there is no risk when in fact a risk exists. Thus, for exposure and toxicity parameters for which site-specific information is lacking, assumed values should consistently be biased in the direction of overestimating risk. This ensures that sites that might pose an ecological risk are studied further. Without this bias, a screening evaluation could not provide a defensible conclusion that negligible ecological risk exists or that certain contaminants and exposure pathways can be eliminated from consideration.

- Has contamination migrated from source areas and resulted in "off-site" impacts or the threat of impacts in addition to on-site threats or impacts?

These questions should be answered using the site reports, maps (e.g., U.S. Geological Survey, National Wetlands Inventory), available aerial photographs, communication with appropriate agencies (e.g., U.S. Fish and Wildlife Service, National Oceanic and Atmospheric Administration, State Natural Heritage Programs), and a site visit. Activities that should be conducted during the site visit include:

- Note the layout and topography of the site;
- Note and describe any water bodies and wetlands;
- Identify and map evidence indicating contamination or potential contamination (e.g., areas of no vegetation, runoff gullies to surface waters);
- Describe existing aquatic, terrestrial, and wetland ecological habitat types (e.g., forest, old field), and estimate the area covered by those habitats;
- Note any potentially sensitive environments (see Section 1.2.3 for examples of sensitive environments);
- Describe and, if possible, map soil and water types, land uses, and the dominant vegetation species present; and
- Record any observations of animal species or sign of a species.

Mapping can be useful in establishing a "picture" of the site to assist in problem formulation. The completed checklist (U.S. EPA, 1997) will provide information regarding habitats and species potentially or actually present on site, potential contaminant migration pathways, exposure pathways, and the potential for non-chemical stresses at the site.

After finishing the checklist, it might be possible to determine that present or future ecological impacts are negligible because complete exposure pathways do not exist and could not exist in the future. Many Superfund sites are located in highly industrialized areas where there could be few if any ecological receptors or where site-related impacts might be indistinguishable from non-site-related impacts (see Highlight 1-2). For such sites, remediation to reduce ecological risks might not be needed. However, all sites should be evaluated by qualified personnel to determine whether this conclusion is appropriate.

Other Superfund sites are located in less disturbed areas with protected or sensitive environments that could be at risk of adverse effects from contaminants from the site. State and federal laws (e.g., the Clean Water Act, the Endangered Species Act) designate certain types of environments as requiring protection. Other types of habitats unique to certain areas

also could need special consideration in the risk assessment (see Section 1.2.3).

1.2.2 Contaminant Fate and Transport

During problem formulation, pathways for migration of a contaminant (e.g., windblown dust, surface water runoff, erosion) should be identified. These pathways can exhibit a decreasing gradient of contamination with increasing distance from a site. There are exceptions, however, because physical and chemical characteristics of the media also influence contaminant distribution (e.g., the pattern of sediment deposition in streams varies depending on stream flow and bottom characteristics). For the screening-level risk assessment, the highest contaminant concentrations measured on the site should be documented for each medium.

HIGHLIGHT 1-2 Industrial or Urban Settings

Many hazardous waste sites exist in currently or historically industrialized or urbanized areas. In these instances, it can be difficult to distinguish between impacts related to contaminants from a particular site and impacts related to non-contaminant stressors or to contaminants from other sites. However, even in these cases, it could be appropriate to take some remedial actions based on ecological risks. These actions might be limited to source removal or might be more extensive. An ecological risk assessment can assist the risk manager in determining what action, if any, is appropriate.

1.2.3 Ecotoxicity and Potential Receptors

Understanding the toxic mechanism of a contaminant helps to evaluate the importance of potential exposure pathways (see Section 1.2.4) and to focus the selection of assessment endpoints (see Section 1.2.5). Some contaminants, for example, affect primarily vertebrate animals by interfering with organ systems not found in invertebrates or plants (e.g., distal tubules of vertebrate kidneys, vertebrate hormone systems). Other substances might affect primarily certain insect groups (e.g., by interfering with hormones needed for metamorphosis), plants (e.g., herbicides), or other groups of organisms. For substances that affect, for example, reproduction of mammals at much lower environmental exposure levels than they affect other groups of organisms, the screening-level risk assessment can initially focus on exposure pathways and risks to mammals. Example 1-1 illustrates this point using the PCB site example provided in Appendix A. A review of some of the more recent ecological risk and toxicity assessment literature can help identify likely effects of the more common contaminants at Superfund sites.

An experienced biologist or ecologist can determine what plants, animals, and habitats exist or can be expected to exist in the area of the Superfund site. Exhibit 1-1, adapted from the Superfund Hazard Ranking System, is a partial list of types of sensitive environments that could require protection or special consideration. Information obtained for the environmental checklist (Section 1.2.1), existing information and maps, and aerial photographs should be used to identify the presence of sensitive environments on or near a site that might be threatened by contaminants from the site.

EXAMPLE 1-1 Ecotoxicity-PCB Site

Some PCBs are reproductive toxins in mammals (Ringer et al., 1972; Aulerich et al., 1985; Wren et al., 1991; Kamrin and Ringer, 1996). When ingested, they induce (i.e., increase concentrations and activity of) enzymes in the liver, which might affect the metabolism of some steroid hormones (Rice and O'Keefe, 1995). Whatever the mechanism of action, several physiological functions that are controlled by steroid hormones can be altered by the exposure of mammals to certain PCBs, and reproduction appears to be the most sensitive endpoint for PCB toxicity in mammals (Rice and O'Keefe, 1995). Given this information, the screening ecological risk assessment should include potential exposure pathways for mammals to PCBs that are reproductive toxins (see Example 1-2).

1.2.4 Complete Exposure Pathways

Evaluating potential exposure pathways is one of the primary tasks of the screening-level ecological characterization of the site. For an exposure pathway to be complete, a contaminant must be able to travel from the source to ecological receptors and to be taken up by the receptors via one or more exposure routes. (Highlight 1-3 defines exposure pathway and exposure route.) Identifying complete exposure pathways prior to a quantitative evaluation of toxicity allows the assessment to focus on only those contaminants that can reach ecological receptors.

Different exposure routes are important for different groups of organisms. For terrestrial animals, three basic exposure routes need to be evaluated: inhalation, ingestion, and dermal absorption. For terrestrial plants, root absorption of contaminants in soils and leaf absorption of contaminants evaporating from the soil or deposited on the leaves are of concern at Superfund sites. For aquatic animals, direct contact (of water or sediment with the gills or integument) and ingestion of food (and sometimes sediments) should be considered. For aquatic plants, direct contact with water, and sometimes with air or sediments, is of primary concern.

The most likely exposure pathways and exposure routes also are related to the physical and chemical properties of the contaminant (e.g., whether or not the contaminant is bound to a matrix, such as organic carbon). Of the basic exposure routes identified above, more information generally is available to quantify exposure levels for ingestion by terrestrial animals and for direct contact with water or sediments by aquatic organisms than for other exposure routes and receptors. Although other exposure routes can be important, more

EXHIBIT 1-1
List of Sensitive Environments in the Hazard Ranking System^a

Critical habitat for Federal designated endangered or threatened species
Marine Sanctuary
National Park
Designated Federal Wilderness Area
Areas identified under the Coastal Zone Management Act
Sensitive areas identified under the National Estuary Program or Near Coastal Waters Program
Critical areas identified under the Clean Lakes Program
National Monument
National Seashore Recreational Area
National Lakeshore Recreational Area
Habitat known to be used by Federal designated or proposed endangered or threatened species
National Preserve
National or State Wildlife Refuge
Unit of Coastal Barrier Resources System
Coastal Barrier (undeveloped)
Federal land designated for protection of natural ecosystems
Administratively Proposed Federal Wilderness Area
Spawning areas critical for the maintenance of fish/shellfish species within river, lake, or coastal tidal waters
Migratory pathways and feeding areas critical for maintenance of anadromous fish species within river reaches or areas in lakes or coastal tidal waters in which the fish spend extended periods of time
Terrestrial areas utilized for breeding by large or dense aggregations of animals
National river reach designated as Recreational
Habitat known to be used by state designated endangered or threatened species
Habitat known to be used by species under review as to its Federal endangered or threatened status
Coastal Barrier (partially developed)
Federally-designated Scenic or Wild River
State land designated for wildlife or game management
State-designated Scenic or Wild River
State-designated Natural Areas
Particular areas, relatively small in size, important to maintenance of unique biotic communities
State-designated areas for protection or maintenance of aquatic life
Wetlands^b

^a The categories are listed in groups from those assigned higher factor values to those assigned lower factor values in the Hazard Ranking System (HRS) for listing hazardous waste sites on the National Priorities List (U.S. EPA, 1990b). See *Federal Register*, Vol. 55, pp. 51624 and 51648 for additional information regarding definitions.

^b Under the HRS, wetlands are rated on the basis of size. See *Federal Register*, Vol. 55, pp. 51625 and 51662 for additional information.

assumptions are needed to estimate exposure levels for those routes, and the results are less certain. Professional judgment is needed to determine if evaluating those routes sufficiently improves a risk assessment to warrant the effort.

If an exposure pathway is not complete for a specific contaminant (i.e., ecological receptors cannot be exposed to the contaminant), that exposure pathway does not need to be evaluated further. For example, suppose a contaminant that impairs reproduction in mammals occurs only in soils that are well below the root zone of plants that occur or are expected to occur on a site. Herbivorous mammals would not be exposed to the contaminant through their diets because plants would not be contaminated. Assuming that most soil macroinvertebrates available for ingestion live in the root zone, insectivorous mammals also would be unlikely to be exposed. In this case, a complete exposure pathway for this contaminant for ground-dwelling mammals would not exist, and the contaminant would not pose a significant risk to this group of organisms. Secondary questions might include whether the contaminant is leaching from the soil to ground water that discharges to surface water, thereby posing a risk to the aquatic environment or to terrestrial mammals that drink the water or consume aquatic prey. Example 1-2 illustrates the process of identifying complete exposure pathways based on the hypothetical PCB site described in Appendix A.

HIGHLIGHT 1-3 Exposure Pathway and Exposure Route

Exposure Pathway: The pathway by which a contaminant travels from a source (e.g., drums, contaminated soils) to receptors. A pathway can involve multiple media (e.g., soil runoff to surface waters and sedimentation, or volatilization to the atmosphere).

Exposure Route: A point of contact/entry of a contaminant from the environment into an organism (e.g., inhalation, ingestion, dermal absorption).

1.2.5 Assessment and Measurement Endpoints

For the screening-level ecological risk assessment, assessment endpoints are any adverse effects on ecological receptors, where receptors are plant and animal populations and communities, habitats, and sensitive environments. Adverse effects on populations can be inferred from measures related to impaired reproduction, growth, and survival. Adverse effects on communities can be inferred from changes in community structure or function. Adverse effects on habitats can be inferred from changes in composition and characteristics that reduce the habitats' ability to support plant and animal populations and communities.

Many of the screening ecotoxicity values now available or likely to be available in the future for the Superfund program (see Section 1.3) are based on generic assessment endpoints (e.g., protection of aquatic communities from changes in structure or function) and are assumed to be widely applicable to sites around the United States.

EXAMPLE 1-2

Complete Exposure Pathways for Mammals-PCB Site

Three possible exposure pathways for mammals were evaluated at the PCB Site: inhalation, ingestion through the food chain, and incidental soil/sediment ingestion.

Inhalation. PCBs are not highly volatile, so the inhalation of PCB vapors by mammals would be an essentially incomplete exposure pathway. Inhalation of PCBs adsorbed to soil particles might need consideration in areas with exposed soils, but this site is well vegetated.

Ingestion through the food chain. PCBs tend to bioaccumulate and biomagnify in food chains. PCBs in soils are not taken up by most plants, but are accumulated by soil macroinvertebrates. Thus, in areas without significant soil deposition on the surfaces of plants, mammalian herbivores would not be exposed to PCBs in most of their diet. In contrast, mammalian insectivores, such as shrews, could be exposed to PCBs in most of their diet. For PCBs, the ingestion route for mammals would be essentially incomplete for herbivores but complete for insectivores. For the PCB site, therefore, the ingestion exposure route for a mammalian insectivore (e.g., shrew) would be a complete exposure pathway that should be evaluated.

Incidental soil/sediment ingestion. Mammals can ingest some quantity of soils or sediments incidentally, as they groom their fur or consume plants or animals from the soil. Burrowing mammals are likely to ingest greater quantities of soils during grooming than non-burrowing mammals, and mammals that consume plant roots or soil-dwelling macroinvertebrates are likely to ingest greater quantities of soils attached to the surface of their foods than mammals that consume other foods. The intake of PCBs from incidental ingestion of PCB-contaminated soils is difficult to estimate, but for insectivores that forage at ground level, it is likely to be far less than the intake of PCBs in the diet. For herbivores, the incidental intake of PCBs in soils might be higher than the intake of PCBs in their diet, but still less than the intake of PCBs by mammals feeding on soil macroinvertebrates. Thus, the exposure pathway for ground-dwelling mammalian insectivores remains the exposure pathway that should be evaluated.

1.3 SCREENING-LEVEL ECOLOGICAL EFFECTS EVALUATION

The next step in the screening-level risk assessment is the preliminary ecological effects evaluation and the establishment of contaminant exposure levels that represent conservative thresholds for adverse ecological effects. In this guidance, those conservative thresholds are called screening ecotoxicity values. Physical stresses unrelated to contaminants at the site are not the focus of the risk assessment (see Highlight 1-4), although they can be considered later when evaluating effects of remedial alternatives.

A literature search for studies that quantify toxicity (i.e., exposure-response) is necessary to evaluate the likelihood of toxic effects in different groups of organisms. Appendix C provides a basic introduction to conducting a literature search, but an expert should be consulted to minimize time and costs. The toxicity profile should describe the toxic mechanisms of action for the exposure routes being evaluated and the dose or environmental concentration that causes a specified adverse effect.

For each complete exposure pathway, route, and contaminant, a screening ecotoxicity value should be developed.¹ The U.S. EPA Office of Emergency and Remedial Response has developed screening ecotoxicity values [called ecotox threshold values (U.S. EPA, 1996c)]. The values are for surface waters and sediments, and are based on direct exposures routes only; bioaccumulation and biomagnification in food chains have not been accounted for. The following subsections describe preferred data (Section 1.3.1), dose conversions (Section 1.3.2), and analyzing uncertainty in the values (Section 1.3.3).

1.3.1 Preferred Toxicity Data

Screening ecotoxicity values should represent a no-observed-adverse-effect-level (NOAEL) for long-term (chronic) exposures to a contaminant. Ecological effects of most concern are those that can impact populations (or higher levels of biological organization). Those include adverse effects on development, reproduction, and survivorship. Community-level effects also can be of concern, but toxicity data on community-level endpoints are limited and might be difficult to extrapolate from one community to another.

¹ It is possible to conduct a screening risk assessment with limited information and conservative assumptions. If site-specific information is too limited, however, the risk assessment is almost certain to move into Steps 3 through 7, which require field-collected data. The more complete the initial information, the better the decision that can be made at this preliminary stage.

HIGHLIGHT 1-4 Non-Chemical Stressors

Ecosystems can be stressed by physical, as well as by chemical, alterations of their environment. For this reason, EPA's (1992a) *Framework for Ecological Risk Assessment* addresses "stressor-response" evaluation to include all types of stress instead of "dose-response" or "exposure-response" evaluation, which implies that the stressor must be a toxic substance.

For Superfund sites, however, the baseline risk assessment addresses risks from hazardous substances released to the environment, not risks from physical alterations of the environment, unless caused indirectly by a hazardous substances (e.g., loss of vegetation from a chemical release leading to serious erosion). This guidance document, therefore, focuses on exposure-response evaluations for toxic substances. Physical destruction of habitat that might be associated with a particular remedy is considered in the Feasibility Study.

When reviewing the literature, one should be aware of the limitations of published information in characterizing actual or probable hazards at a specific site. U.S. EPA discourages reliance on secondary references because study details relevant for determining the applicability of findings to a given site usually are not reported in secondary sources. Only primary literature that has been carefully reviewed by an ecotoxicologist should be used to support a decision. Several considerations and data preferences are summarized in Highlight 1-5 and described more fully below.

NOAELS and LOAELS. For each contaminant for which a complete exposure pathway/route exists, the literature should be reviewed for the lowest exposure level (e.g., concentration in water or in the diet, ingested dose) shown to produce adverse effects (e.g., reduced growth, impaired reproduction, increased mortality) in a potential receptor species. This value is called a lowest-observed-adverse-effect-level or LOAEL. For those contaminants with documented adverse effects, one also should identify the highest exposure level that is a NOAEL. A NOAEL is more appropriate than a LOAEL to use as an screening ecotoxicity value to ensure that risk is not underestimated (see Highlight 1-6). However, NOAELs currently are not available for many groups of organisms and many chemicals. When a LOAEL value, but not a NOAEL value, is available from the literature, a standard practice is to multiply the LOAEL by 0.1 and to use the product as the screening ecotoxicity value. Support for this practice comes from a data review indicating that 96 percent of chemicals included in the review had LOAEL/NOAEL ratios of five or less, and that all were ten or less (Dourson and Stara, 1983).

Exposure duration. Data from studies of chronic exposure are preferable to data from medium-term (subchronic), short-term (acute), or single-exposure studies because exposures at Superfund remedial sites usually are long-term. Literature reviews by McNamara (1976) and Weil and McCollister (1963) indicate that chronic NOAELs can be

HIGHLIGHT 1-5 Data Hierarchy for Deriving Screening Ecotoxicity Values

To develop a chronic NOAEL for a screening ecotoxicity value from existing literature, the following data hierarchy minimizes extrapolations and uncertainties in the value:

- A NOAEL is preferred to a LOAEL, which is preferred to an LC₅₀ or an EC₅₀.
- Long-term (chronic) studies are preferred to medium-term (subchronic) studies, which are preferred to short-term (acute) studies.
- If exposure at the site is by ingestion, dietary studies are preferred to gavage studies, which are preferred to non-ingestion routes of exposure. Similarly, if exposure at the site is dermal, dermal studies are preferred to studies using other exposure routes.

lower than subchronic (90-day duration for rats) NOAELs by up to a factor of ten.²

Exposure route. The exposure route and medium used in the toxicity study should be comparable to the exposure route in the risk assessment. For example, data from studies where exposure is by gavage generally are not preferred for estimating dietary concentrations that could produce adverse effects, because the rate at which the substance is absorbed from the gastrointestinal tract usually is greater following gavage than following dietary administration. Similarly, intravenous injection of a substance results in "instantaneous absorption" and does not allow the substance to first pass through the liver, as it would following dietary exposure. If it is necessary to attempt to extrapolate toxicity test results from one route of exposure to another, the extrapolation should be performed or reviewed by a toxicologist experienced in route-to-route extrapolations for the class of animals at issue.

HIGHLIGHT 1-6 NOAEL Preferred to LOAEL

Because the NOAEL and LOAEL are estimated by hypothesis testing (i.e., by comparing the response level of a test group to the response level of a control group for a statistically significant difference), the actual proportion of the test animals showing the adverse response at an identified LOAEL depends on sample size, variability of the response, and the dose interval. LOAELs, and even NOAELs, can represent a 30 percent or higher effect level for the minimum sample sizes recommended for standard test protocols. For this reason, U.S. EPA recommends that the more conservative NOAELs, instead of LOAELs, are used to determine a screening exposure level that is unlikely to adversely impact populations. If dose-response data are available, a site-specific low-effect level may be determined.

Field versus laboratory. Most toxicity studies evaluate effects of a single contaminant on a single species under controlled laboratory conditions. Results from these studies might not be directly applicable to the field, where organisms typically are exposed to more than one contaminant in environmental situations that are not comparable to a laboratory setting and where genetic composition of the population can be more heterogeneous than that of organisms bred for laboratory use. In addition, the bioavailability of a contaminant might be different at a site than in a laboratory toxicity test. In a field situation, organisms also will be subject to other environmental variables, such as unusual weather conditions, infectious diseases, and food shortages. These variables can have either positive or negative effects on

² The literature reviews of McNamara (1976) and Weil and McCollister (1963) included both rodent and non-rodent species. The duration of the subchronic exposure usually was 90 days, but ranged from 30 to 210 days. A wide variety of endpoints and criteria for adverse effects were included in these reviews. Despite this variation in the original studies, their findings provide a general indication of the ratio between subchronic to chronic NOAELs for effects other than cancer and reproductive effects. For some chemicals, chronic dosing resulted in increased chemical tolerance. For over 50 percent of the compounds tested, the chronic NOAEL was less than the 90-day NOAEL by a factor of 2 or less. However, in a few cases, the chronic NOAEL was up to a factor of 10 less than the subchronic NOAEL (U.S. EPA, 1993e).

the organism's response to a toxic contaminant that only a site-specific field study would be able to evaluate. Moreover, single-species toxicity tests seldom provide information regarding toxicant-related changes in community interactions (e.g., behavioral changes in prey species that make them more susceptible to predation).

1.3.2 Dose Conversions

For some data reported in the literature, conversions are necessary to allow the data to be used for species other than those tested or for measures of exposure other than those reported. Many doses in laboratory studies are reported in terms of concentration in the diet (e.g., mg contaminant/kg diet or ppm in the diet). Dietary concentrations can be converted to dose (e.g., mg contaminant/kg body weight/day) for comparison with estimated contaminant intake levels in the receptor species.

When converting doses, it is important to identify whether weights are measured as wet or dry weights. Usually, body weights are reported on a wet-weight, not dry-weight basis. Concentration of the contaminant in the diet might be reported on a wet- or dry-weight basis.

Ingestion rates and body weights for a test species often are reported in a toxicity study or can be obtained from other literature sources (e.g., U.S. EPA, 1993a,b). For extrapolations between animal species with different metabolic rates as well as dietary composition, consult U.S. EPA 1992e and 1996b.

1.3.3 Uncertainty Assessment

Professional judgment is needed to determine the uncertainty associated with information taken from the literature and any extrapolations used in developing a screening ecotoxicity value. The risk assessor should be consistently conservative in selecting literature values and describe the limitations of using those values in the context of a particular site. Consideration of the study design, endpoints, and other factors are important in determining the utility of toxicity data in the screening-level risk assessment. All of those factors should be addressed in a brief evaluation of uncertainties prior to the screening-level risk calculation.

1.4 SUMMARY

At the conclusion of the screening-level problem formulation and ecological effects evaluation, the following information should have been compiled:

- Environmental setting and contaminants known or suspected to exist at the site and the maximum concentrations present (for each medium);
- Contaminant fate and transport mechanisms that might exist at the site;

- The mechanisms of ecotoxicity associated with contaminants and likely categories of receptors that could be affected;
- The complete exposure pathways that might exist at the site from contaminant sources to receptors that could be affected; and
- Screening ecotoxicity values equivalent to chronic NOAELs based on conservative assumptions.

For the screening-level ecological risk assessment, assessment endpoints will include any likely adverse ecological effects on receptors for which exposure pathways are complete, as determined from the information listed above. Measurement endpoints will be based on the available literature regarding mechanisms of toxicity and will be used to establish the screening ecotoxicity values. Those values will be used with estimated exposure levels to screen for ecological risks, as described in Step 2.

STEP 2: SCREENING-LEVEL EXPOSURE ESTIMATE AND RISK CALCULATION

OVERVIEW

The screening-level exposure estimate and risk calculation comprise the second step in the ecological risk screening for a site. Risk is estimated by comparing maximum documented exposure concentrations with the ecotoxicity screening values from Step 1. At the conclusion of Step 2, the risk manager and risk assessment team will decide that either the screening-level ecological risk assessment is adequate to determine that ecological threats are negligible, or the process should continue to a more detailed ecological risk assessment (Steps 3 through 7). If the process continues, the screening-level assessment serves to identify exposure pathways and preliminary contaminants of concern for the baseline risk assessment by eliminating those contaminants and exposure pathways that pose negligible risks.

2.1 INTRODUCTION

This step includes estimating exposure levels and screening for ecological risks as the last two phases of the screening-level ecological risk assessment. The process concludes with a SMDP at which it is determined that: (1) ecological threats are negligible; (2) the ecological risk assessment should continue to determine whether a risk exists; or (3) there is a potential for adverse ecological effects, and a more detailed ecological risk assessment, incorporating more site-specific information, is needed.

Section 2.2 describes the screening-level exposure assessment, focusing on the complete exposure pathways identified in Step 1. Section 2.3 describes the risk calculation process, including estimating a hazard quotient, documenting the uncertainties in the quotient, and summarizing the overall confidence in the screening-level ecological risk assessment. Section 2.4 describes the SMDP that concludes Step 2.

2.2 SCREENING-LEVEL EXPOSURE ESTIMATES

To estimate exposures for the screening-level ecological risk calculation, on-site contaminant levels and general information on the types of biological receptors that might be exposed should be known from Step 1. Only complete exposure pathways should be evaluated. For these, the highest measured or estimated on-site contaminant concentration for

each environmental medium should be used to estimate exposures. This should ensure that potential ecological threats are not missed.

2.2.1 Exposure Parameters

For parameters needed to estimate exposures for which sound site-specific information is lacking or difficult to develop, conservative assumptions should be used at this screening level. Examples of conservative assumptions are listed below and described in the following paragraphs:

- Area-use factor – 100 percent (factor related to home range and population density; see Highlight 2-1);
- Bioavailability – 100 percent;
- Life stage – most sensitive life stage;
- Body weight and food ingestion rate – minimum body weight to maximum ingestion rate; and
- Dietary composition – 100 percent of diet consists of the most contaminated dietary component.

Area-use factor. For the screening-level exposure estimate for terrestrial animals, assume that the home range of one or more animals is entirely within the contaminated area, and thus the animals are exposed 100 percent of the time. This is a conservative assumption and, as an assumption, is only applicable to the screening-level phase of the risk assessment. Species- and site-specific home range information would be needed later, in Step 6, to estimate more accurately the percentage of time an animal would use a contaminated area. Also evaluate the possibility that some species might actually focus their activities in contaminated areas of the site. For example, if contamination has reduced emergent vegetation in a pond, the pond might be more heavily used for feeding by waterfowl than uncontaminated ponds with little open water.

Bioavailability. For the screening-level exposure estimate, in the absence of site-specific information, assume that the bioavailability of contaminants at the site is 100 percent. For example, at the screening-level, lead would be assumed to be 100 percent bioavailable to mammals. While some literature indicates that mammals absorb approximately 10 percent of ingested lead, absorption efficiency can be higher, up to about 60 percent, because dietary

HIGHLIGHT 2-1 Area-use Factor

An animal's area-use factor can be defined as the ratio of the area of contamination (or the site area under investigation) to the area used by the animal, e.g., its home range, breeding range, or feeding/foraging range. To ensure that ecological risks are not underestimated, the highest density and smallest area used by each animal should be assumed. This allows the maximum number of animals to be exposed to site contaminants and makes it more likely that "hot spots" (i.e., areas of unusually high contamination levels) will be significant proportions of an individual animal's home range.

factors such as fasting, and calcium and phosphate content of the diet, can affect the absorption rate (Kenzaburo, 1986). Because few species have been tested for bioavailability, and because Steps 3 through 6 provide an opportunity for this issue to be addressed specifically, the most conservative assumption is appropriate for this step.

Life stage. For the screening-level assessment, assume that the most sensitive life stages are present. If an early life stage is the most sensitive, the population should be assumed to include or to be in that life stage. For vertebrate populations, it is likely that most of the population is not in the most sensitive life stage most of the time. However, for many invertebrate species, the entire population can be at an early stage of development during certain seasons.

Body weight and food ingestion rates. Estimates of body weight and food ingestion rates of the receptor animals also should be made conservatively to maximize the dose (intake of contaminants) on a body-weight basis and to avoid understating risk, although uncertainties in these factors are far less than the uncertainties associated with the environmental contaminant concentrations. U.S. EPA's *Wildlife Exposure Factors Handbook* (U.S. EPA, 1993a,b) is a good source or reference to sources of this information.

Bioaccumulation. Bioaccumulation values obtained from a literature search can be used to estimate contaminant accumulation and food-chain transfer at a Superfund site at the screening stage. Because many environmental factors influence the degree of bioaccumulation, sometimes by several orders of magnitude, the most conservative (i.e., highest) bioaccumulation factor (BAF) reported in the literature should be used in the absence of site-specific information.

Dietary composition. For species that feed on more than one type of food, the screening-level assumption should be that the diet is composed entirely of whichever type of food is most contaminated. For example, if some foods (e.g., insects) are likely to be more contaminated than other foods (e.g., seeds and fruits) typical in the diet of a receptor species, assume that the receptor species feeds exclusively on the more contaminated type of food. Again, EPA's *Wildlife Exposure Factors Handbook* (U.S. EPA, 1993a,b) is a good source or reference to sources of this information.

2.2.2 Uncertainty Assessment

Professional judgment is needed to determine the uncertainty associated with information taken from the literature and any extrapolations used in developing a parameter to estimate exposures. All assumptions used to estimate exposures should be stated, including some description of the degree of bias possible in each. Where literature values are used, an indication of the range of values that could be considered appropriate also should be indicated.

2.3 SCREENING-LEVEL RISK CALCULATION

A quantitative screening-level risk can be estimated using the exposure estimates developed according to Section 2.2 and the screening ecotoxicity values developed according to Section 1.3. For the screening-level risk calculation, the hazard quotient approach, which compares point estimates of screening ecotoxicity values and exposure values, is adequate to estimate risk. As described in Section 1.3, a screening ecotoxicity value should be equivalent to a documented and/or best conservatively estimated chronic NOAEL. Thus, for each contaminant and environmental medium, the hazard quotient can be expressed as the ratio of a potential exposure level to the NOAEL:

$$HQ = \frac{Dose}{NOAEL} \quad or \quad HQ = \frac{EEC}{NOAEL}$$

where:

HQ = hazard quotient;

Dose = estimated contaminant intake at the site (e.g., mg contaminant/kg body weight per day);

EEC = estimated environmental concentration at the site (e.g., mg contaminant/L water, mg contaminant/kg soil, mg contaminant/kg food);
and

NOAEL = no-observed-adverse-effects-level (in units that match the dose or EEC).

An HQ less than one (unity) indicates that the contaminant alone is unlikely to cause adverse ecological effects. If multiple contaminants of potential ecological concern exist at the site, it might be appropriate to sum the HQs for receptors that could be simultaneously exposed to the contaminants that produce effects by the same toxic mechanism (U.S. EPA, 1986a). The sum of the HQs is called a hazard index (HI); (see Highlight 2-2). An HI less than one indicates that the group of contaminants is unlikely to cause adverse ecological effects. An HQ or HI less than one does not indicate the absence of ecological risk; rather, it should be interpreted based on the severity of the effect reported and the magnitude of the calculated quotient. As certainty in the exposure concentrations and the NOAEL increase, there is greater confidence in the predictive value of the hazard quotient model, and unity (HQ = 1) becomes a more certain pass/fail decision point.

The screening-level risk calculation is a conservative estimate to ensure that potential ecological threats are not overlooked. The calculation is used to document a decision about whether or not there is a negligible potential for ecological impacts, based on the information available at this stage. If the potential for ecological impacts exists, this calculation can be

used to eliminate the negligible-risk combinations of contaminants and exposure pathways from further consideration.

If the screening-level risk assessment indicates that adverse ecological effects are possible at environmental concentrations below standard quantitation limits, a "non detect" based on those limits cannot be used to support a "no risk" decision. Instead, the risk assessment team and risk manager should request appropriate detection limits or agree to continue to Steps 3 through 7, where exposure concentrations will be estimated from other information (e.g., fate-and-transport modeling, assumed or estimated values for non-detects).

2.4 SCIENTIFIC/MANAGEMENT DECISION POINT (SMDP)

At the end of Step 2, the lead risk assessor communicates the results of the preliminary ecological risk assessment to the risk manager. The risk manager needs to decide whether the information available is adequate to make a risk management decision and might require technical advice from the ecological risk assessment team to reach a decision. There are only three possible decisions at this point:

- (1) There is adequate information to conclude that ecological risks are negligible and therefore no need for remediation on the basis of ecological risk;
- (2) The information is not adequate to make a decision at this point, and the ecological risk assessment process will continue to Step 3; or
- (3) The information indicates a potential for adverse ecological effects, and a more thorough assessment is warranted.

Note that the SMDP made at the end of the screening-level risk calculation will not set a preliminary cleanup goal. Screening ecotoxicity values are derived to avoid underestimating risk. Requiring a cleanup based solely on those values would not be technically defensible.

HIGHLIGHT 2-2 Hazard Index (HI) Calculation

For contaminants that produce adverse effects by the same toxic mechanism:

$$\text{Hazard Index} = \frac{EEC_1}{NOAEL_1} + \frac{EEC_2}{NOAEL_2} + \dots + \frac{EEC_i}{NOAEL_i}$$

where:

EEC_i = estimated environmental concentration for the i^{th} contaminant; and

$NOAEL_i$ = NOAEL for the i^{th} contaminant (expressed either as a dose or environmental concentration).

The EEC and the NOAEL are expressed in the same units and represent the same exposure period (e.g., chronic). Dose could be substituted for EEC throughout provided the NOAEL is expressed as a dose.

The risk manager should document both the decision and the basis for it. If the risk characterization supports the first decision (i.e., negligible risk), the ecological risk assessment process ends here with appropriate documentation to support the decision. The documentation should include all analyses and references used in the assessment, including a discussion of the uncertainties associated with the HQ and HI estimates.

For assessments that proceed to Step 3, the screening-level analysis in Step 2 can indicate and justify which contaminants and exposure pathways can be eliminated from further assessment because they are unlikely to pose a substantive risk. (If new contaminants are discovered or contaminants are found at higher concentrations later in the site investigation, those contaminants might need to be added to the ecological risk assessment at that time.)

U.S. EPA must be confident that the SMDP made after completion of this calculation will protect the ecological components of the environment. The decision to continue beyond the screening-level risk calculation does not indicate whether remediation is necessary at the site. That decision will be made in Step 8 of the process.

2.5 SUMMARY

At the conclusion of the exposure estimate and screening-level risk calculation step, the following information should have been compiled:

- (1) Exposure estimates based on conservative assumptions and maximum concentrations present; and
- (2) Hazard quotients (or hazard indices) indicating which, if any, contaminants and exposure pathways might pose ecological threats.

Based on the results of the screening-level ecological risk calculation, the risk manager and lead risk assessor will determine whether or not contaminants from the site pose an ecological threat. If there are sufficient data to determine that ecological threats are negligible, the ecological risk assessment will be complete at this step with a finding of negligible ecological risk. If the data indicate that there is (or might be) a risk of adverse ecological effects, the ecological risk assessment process will continue.

Conservative assumptions have been used for each step of the screening-level ecological risk assessment. Therefore, requiring a cleanup based solely on this information would not be technically defensible. To end the assessment at this stage, the conclusion of negligible ecological risk must be adequately documented and technically defensible. A lack of information on the toxicity of a contaminant or on complete exposure pathways will result in a decision to continue with the ecological risk assessment process (Steps 3 through 7)—not

a decision to delay the ecological risk assessment until a later date when more information might be available.

STEP 3: BASELINE RISK ASSESSMENT PROBLEM FORMULATION

OVERVIEW

Step 3 of the eight-step process initiates the problem-formulation phase of the baseline ecological risk assessment. Step 3 refines the screening-level problem formulation and, with input from stakeholders and other involved parties, expands on the ecological issues that are of concern at the particular site. In the screening-level assessment, conservative assumptions were used where site-specific information was lacking. In Step 3, the results of the screening assessment and additional site-specific information are used to determine the scope and goals of the baseline ecological risk assessment. Steps 3 through 7 are required only for sites for which the screening-level assessment indicated a need for further ecological risk evaluation.

Problem formulation at Step 3 includes several activities:

- Refining preliminary contaminants of ecological concern;
- Further characterizing ecological effects of contaminants;
- Reviewing and refining information on contaminant fate and transport, complete exposure pathways, and ecosystems potentially at risk;
- Selecting assessment endpoints; and
- Developing a conceptual model with working hypotheses or questions that the site investigation will address.

At the conclusion of Step 3, there is a SMDP, which consists of agreement on four items: the assessment endpoints, the exposure pathways, the risk questions, and conceptual model integrating these components. The products of Step 3 are used to select measurement endpoints and to develop the ecological risk assessment work plan (WP) and sampling and analysis plan (SAP) for the site in Step 4. Steps 3 and 4 are, effectively, the data quality objective (DQO) process for the baseline ecological risk assessment.

3.1 THE PROBLEM-FORMULATION PROCESS

In Step 3, problem formulation establishes the goals, breadth, and focus of the baseline ecological risk assessment. It also establishes the assessment endpoints, or specific ecological values to be protected (U.S. EPA, 1992a). Through Step 3, the questions and issues that need to be addressed in the baseline ecological risk assessment are defined based on potentially complete exposure pathways and ecological effects. A conceptual model of the site is

developed that includes questions about the assessment endpoints and the relationship between exposure and effects. Step 3 culminates in an SMDP, which is agreement between the risk manager and risk assessor on the assessment endpoints, exposure pathways, and questions as portrayed in the conceptual model of the site.

The conceptual model, which is completed in Step 4, also will describe the approach, types of data, and analytical tools to be used for the analysis phase of the ecological risk assessment (Step 6). Those components of the conceptual model are formally described in the ecological risk WP and SAP in Step 4 of this eight-step process. If there is not agreement among the risk manager, lead risk assessor, and the other professionals involved with the ecological risk assessment on the initial conceptual model developed in Step 3, the final conceptual model and field study design developed in Step 4 might not resolve the issues that must be considered to manage risks effectively.

The complexity of questions developed during problem formulation does not depend on the size of a site or the magnitude of its contamination. Large areas of contamination can provoke simple questions and, conversely, small sites with numerous contaminants can require a complex series of questions and assessment endpoints. There is no rule that can be applied to gauge the effort needed for an ecological risk assessment based on site size or number of contaminants; each site should be evaluated individually.

At the beginning of Step 3, some basic information should exist for the site. At a minimum, information should be available from the site history, PA, SI, and Steps 1 and 2 of this eight-step process. For large or complex sites, information might be available from earlier site investigations.

It is important to be as complete as possible early in the process so that Steps 3 through 8 need not be repeated. Repeating the selection of assessment endpoints and/or the questions and hypotheses concerning those endpoints is appropriate only if new information indicating new threats becomes available. The SMDP process should prevent having to return to the problem formulation step because of changing opinions on the questions being asked. Repetition of Step 3 should not be confused with the intentional tiering (or phasing) of ecological site investigations at large or complex sites (see Highlight 3-1). The process of problem formulation at complex sites is the same as at more simple sites, but the number, complexity, and/or level of resolution of the questions and hypotheses can be greater at complex sites.

While problem formulation is conceptually simple, in practice it can be a complex and interactive process. Defining the ecological problems to be addressed during the baseline risk assessment involves identifying toxic mechanisms of the contaminants, characterizing potential receptors, and estimating exposure and potential ecological effects. Problem formulation also constitutes the DQO process for the baseline ecological risk assessment (U.S. EPA, 1993c,d).

The remainder of this section describes six activities to be conducted prior to the SMDP for this step: refining preliminary contaminants of ecological concern (Section 3.2); a literature search on the potential ecological effects of the contaminants (Section 3.3); qualitative evaluation of complete exposure pathways and ecosystems potentially at risk (Section 3.4); selecting assessment endpoints (Section 3.5); and developing the conceptual model and establishing risk questions (Section 3.6).

3.2 REFINEMENT OF PRELIMINARY CONTAMINANTS OF CONCERN

The results of the screening-level risk assessment (Steps 1 and 2) should have indicated which contaminants found at the site can be eliminated from further consideration and which should be evaluated further. It is important to realize that contaminants that might pose an ecological risk can be different from those that might pose a human health risk because of differing exposure pathways, sensitivities, and responses to contaminants.

The initial list of contaminants investigated in Steps 1 and 2 included all contaminants identified or suspected to be at the site. During Steps 1 and 2, it is likely that several of the contaminants found at the site were eliminated from further assessment because the risk screen indicated that they posed a negligible ecological risk. Because of the conservative assumptions used during the risk screen, some of the contaminants retained for Step 3 might also pose negligible risk. At this stage, the risk assessor should review the assumptions used (e.g., 100 percent bioavailability) against values reported in the literature (e.g., only up to 60 percent for a particular contaminant), and consider how the HQs would change if more realistic conservative assumptions were used instead (see Section 3.4.1). For those contaminants for which the HQs drop to near or below unity, the lead risk assessor and risk manager should discuss and agree on which can be eliminated from further consideration at

HIGHLIGHT 3-1 Tiering an Ecological Risk Assessment

Most ecological risk assessments at Superfund sites are at least a two-tier process. Steps 1 and 2 of this guidance serve as a first, or screening, tier prior to expending a larger effort for a detailed, site-specific ecological risk assessment. The baseline risk assessment may serve as the second tier. Additional tiers could be needed in the baseline risk assessment for large or complex sites where there is a need to sequentially test interdependent hypotheses developed during problem formulation (i.e., evaluating the results of one field assessment before designing a subsequent field study).

While tiering can be an effective way to manage site investigations, multiple sampling phases typically require some resampling of matrices sampled during earlier tiers and increased field-mobilization costs. Thus, in some cases, a multi-tiered ecological risk assessment might cost more than a two-tiered assessment. The benefits of tiering should be weighed against the costs.

this time. The reasons for dropping any contaminants from consideration at this step must be documented in the baseline risk assessment.

Sometimes, new information becomes available that indicates the initial assumptions that screened some contaminants out in Step 2 are no longer valid (e.g., site contaminant levels are higher than originally reported). In this case, contaminants can be placed back on the list of contaminants to be investigated with that justification.

Note that a contaminant should not be eliminated from the list of contaminants to be investigated only because toxicity information is lacking; instead, limited or missing toxicity information must be addressed using best professional judgment and discussed as an uncertainty.

3.3 LITERATURE SEARCH ON KNOWN ECOLOGICAL EFFECTS

The literature search conducted in Step 1 for the screening-level risk assessment might need to be expanded to obtain the information needed for the more detailed problem formulation phase of the baseline ecological risk assessment. The literature search should identify NOAELs, LOAELs, exposure-response functions, and the mechanisms of toxic responses for contaminants for which those data were not collected in Step 1. Appendix C presents a discussion of some of the factors important in conducting a literature search. Several U.S. EPA publications (e.g., U.S. EPA, 1995a,e,g,h) provide a window to original toxicity literature for contaminants often found at Superfund sites. For all retained contaminants, it is important to obtain and review the primary literature.

3.4 CONTAMINANT FATE AND TRANSPORT, ECOSYSTEMS POTENTIALLY AT RISK, AND COMPLETE EXPOSURE PATHWAYS

A preliminary identification of contaminant fate and transport, ecosystems potentially at risk, and complete exposure pathways was conducted in the screening ecological risk assessment. In Step 3, the exposure pathways and the ecosystems associated with the assessment endpoints that were retained by the screening risk assessment are evaluated in more detail. This effort typically involves compiling additional information on:

- (1) The environmental fate and transport of the contaminants;
- (2) The ecological setting and general flora and fauna of the site (including habitat, potential receptors, etc.); and
- (3) The magnitude and extent of contamination, including its spatial and temporal variability relative to the assessment endpoints.

For individual contaminants, it is frequently possible to reduce the number of exposure pathways that need to be evaluated to one or a few "critical exposure pathways" which (1) reflect maximum exposures of receptors within the ecosystem, or (2) constitute exposure pathways to ecological receptors sensitive to the contaminant. The critical exposure pathways influence the selection of assessment endpoints for a particular site. If multiple critical exposure pathways exist, they each should be evaluated, because it is often difficult to predict which pathways could be responsible for the greatest ecological risk.

3.4.1 Contaminant Fate and Transport

Information on how the contaminants will or could be transported or transformed in the environment physically, chemically, and biologically is used to identify the exposure pathways that might lead to significant ecological effects (see Highlight 3-2). Chemically, contaminants can undergo several processes in the environment:

- Degradation,³
- Complexation,
- Ionization,
- Precipitation, and/or
- Adsorption.

Physically, contaminants might move through the environment by one or more means:

- Volatilization,
- Erosion,
- Deposition (contaminant sinks),
- Weathering of parent material with subsequent transport, and/or
- Water transport:
 - in solution,
 - as suspended material in the water, and
 - bulk transport of solid material.

HIGHLIGHT 3-2 Environmental Fate and Exposure

If a contaminant in an aquatic ecosystem is highly lipophilic (i.e., essentially insoluble in water), it is likely to partition primarily into sediments and not into the water column. Factors such as sediment particle size and organic carbon influence contaminant partitioning; therefore, these attributes should be characterized when sampling sediments. Similar considerations regarding partitioning should be applied to contaminants in soils.

Several biological processes also affect contaminant fate and transport in the environment:

- Bioaccumulation,
- Biodegradation,

³ The product might be more or less toxic than the parent compound.

- Biological transformation,⁴
- Food chain transfers, and/or
- Excretion.

Additional information should be gathered on past as well as current mechanisms of contaminant release from source areas at the site. The mechanisms of release along with the chemical and physical form of a contaminant can affect its fate, transport, and potential for reaching ecological receptors.

A contaminant flow diagram (or exposure pathway diagram) comprises a large part of the conceptual model, as illustrated in Section 3.6. A contaminant flow diagram originates at the primary contaminant source(s) and identifies primary release mechanisms and contaminant transport pathways. The release and movement of the contaminants can create secondary sources (e.g., contaminated sediments in a river; see Example 3-1), and even tertiary sources.

The above information is used to evaluate where the contaminants are likely to partition in the environment, and the bioavailability of the contaminant (historically, currently, or in the future). As indicated in Section 3.2, it might be possible for the risk assessment team and the risk manager to use this information to replace some of the conservative assumptions used in the screening-level risk assessment and to eliminate additional chemicals from further evaluation at this point. Any such negotiations must be documented in the baseline risk assessment.

3.4.2 Ecosystems Potentially at Risk

The ecosystems or habitats potentially at risk depend on the ecological setting of a site. An initial source of information on the ecological setting of a site is the data collected during the preliminary site visit and characterization (Step 1), including the site ecological checklist (Appendix B). The site description should provide answers to several questions including:

- What habitats (e.g., maple-beech hardwood forest, early-successional fields) are present?
- What types of water bodies are present, if any?
- Do any other habitats listed in Exhibit 1-1 exist on or adjacent to the site?

While adequately documented information should be used, it is not critical that complete site setting information be collected during this phase of the risk assessment. However, it is important that habitats at the site are not overlooked; hence, a site visit might be needed to supplement the one conducted during the screening risk assessment. If a habitat

⁴ The product might be more or less toxic than the parent compound.

EXAMPLE 3-1

Exposure Pathway Model- DDT Site

An abandoned pesticide production facility had released DDT to soils through poor handling practices during its operation. Due to erosion of contaminated soils, DDT migrated to stream sediments. The contaminated sediments represent a secondary source that might affect benthic organisms through direct contact or ingestion. Benthic organisms that have accumulated DDT can be consumed by fish, and fish that have accumulated DDT can be consumed by piscivorous birds, which are considered a valuable component of the local ecosystem. This example illustrates how contaminant transport is traced from a primary source to a secondary source and from there through a food chain to an exposure point that can affect an assessment endpoint.

actually present on the site is omitted during the problem formulation phase, this step might need to be repeated later when the habitat is found, resulting in delays and additional costs for the risk assessment.

Available information on ecological effects of contaminants (see Section 3.3) can help focus the assessment on specific ecological resources that should be evaluated more thoroughly, because some groups of organisms can be more sensitive than others to a particular contaminant. For example, a species or group of species could be physiologically sensitive to a particular contaminant (e.g., the contaminant might interfere with its vascular system); or, the species might not be able to metabolize and detoxify the particular contaminant(s) (e.g., honey bees and grass shrimp cannot effectively biodegrade PAHs, whereas fish generally can). Alternatively, an already-stressed population (e.g., due to habitat degradation) could be particularly sensitive to any added stresses.

Variation in sensitivity should not be confused with variation in exposure, which can result from behavioral and dietary differences among species. For example, predators can be exposed to higher levels of contaminants that biomagnify in food chains than herbivores. A specialist predator could feed primarily on one prey type that is a primary receptor of the contaminant. Some species might preferentially feed in a habitat where the contaminant tends to accumulate. On the other hand, a species might change its behavior to avoid contaminated areas. Both sensitivity to toxic effects of a contaminant and behaviors that affect exposure levels can influence risks for particular groups of organisms.

3.4.3 Complete Exposure Pathways

The potentially complete exposure pathways identified in Steps 1 and 2 are described in more detail in Step 3 on the basis of the refined contaminant fate and transport evaluations (Section 3.4.1) and evaluation of potential ecological receptors (Section 3.4.2).

Some of the potentially complete exposure pathways identified in Steps 1 and 2 might be ruled out from further consideration at this time. Sometimes, additional exposure pathways might be identified, particularly those originating from secondary sources. Any data gaps that result in questions about whether an exposure pathway is complete should be identified, and the type of data needed to answer those questions should be described to assist in developing the WP and SAP in Step 4.

During Step 3, the potential for food-chain exposures deserves particular attention. Some contaminants are effectively transferred through food chains, while others are not. To illustrate this point, copper and DDT are compared in Example 3-2.

EXAMPLE 3-2
Potential for Food Chain Transfer—Copper and DDT Sites

Copper can be toxic in aquatic ecosystems and to terrestrial plants. However, it is an essential nutrient for both plants and animals, and organisms can regulate internal copper concentrations within limits. For this reason, copper tends not to accumulate in most organisms or to biomagnify in food chains, and thus tends not to reach levels high enough to cause adverse responses through food chain transfer to upper-trophic-level organisms. (Copper is known to accumulate by several orders of magnitude in phytoplankton and in filter-feeding mollusks, however, and thus can pose a threat to organisms that feed on those components of aquatic ecosystems; U.S. EPA, 1985a.) In contrast, DDT, a contaminant that accumulates in fatty tissues, can biomagnify in many different types of food chains. Upper-trophic-level species (such as predatory birds), therefore, are likely to be exposed to higher levels of DDT through their prey than are lower-trophic-level species in the ecosystem.

3.5 SELECTION OF ASSESSMENT ENDPOINTS

As noted in the introduction to this guidance, an assessment endpoint is "an explicit expression of the environmental value that is to be protected" (U.S. EPA, 1992a). In human health risk assessment, only one species is evaluated, and cancer and noncancer effects are the usual assessment endpoints. Ecological risk assessment, on the other hand, involves multiple species that are likely to be exposed to differing degrees and to respond differently to the same contaminant. Nonetheless, it is not practical or possible to directly evaluate risks to all of the individual components of the ecosystem at a site. Instead, assessment endpoints focus the risk assessment on particular components of the ecosystem that could be adversely affected by contaminants from the site.

The selection of assessment endpoints includes discussion between the lead risk assessor and the risk manager concerning management policy goals and ecological values. The lead risk assessor and risk manager should seek input from the regional BTAG, PRPs, and other stakeholders associated with a site when identifying assessment endpoints for a site.

Stakeholder input at this stage will help ensure that the risk manager can readily defend the assessment endpoints when making decisions for the site. *ECO Update Volume 3, Number 1*, briefly summarizes the process of selecting assessment endpoints (U.S. EPA, 1995b).

Individual assessment endpoints usually encompass a group of species or populations with some common characteristics, such as a specific exposure route or contaminant sensitivity. Sometimes, individual assessment endpoints are limited to one species (e.g., a species known to be particularly sensitive to a site contaminant). Assessment endpoints can also encompass the typical structure and function of biological communities or ecosystems associated with a site.

Assessment endpoints for the baseline ecological risk assessment must be selected based on the ecosystems, communities, and/or species potentially present at the site. The selection of assessment endpoints depends on:

- (1) The contaminants present and their concentrations;
- (2) Mechanisms of toxicity of the contaminants to different groups of organisms;
- (3) Ecologically relevant receptor groups that are potentially sensitive or highly exposed to the contaminant and attributes of their natural history; and
- (4) Potentially complete exposure pathways.

Thus, the process of selecting assessment endpoints can be intertwined with other phases of problem formulation.

The risk assessment team must think through the contaminant mechanism(s) of ecotoxicity to determine what receptors will or could be at risk. This understanding must include how the adverse effects of the contaminants might be expressed (e.g., eggshell thinning in birds), as well as how the chemical and physical form of the contaminants influence bioavailability and the type and magnitude of adverse response (e.g., inorganic versus organic mercury).

The risk assessment team also should determine if the contaminants can adversely affect organisms in direct contact with the contaminated media (e.g., direct exposure to water, sediment, soil) or if the contaminants accumulate in food chains, resulting in adverse effects in organisms that are not directly exposed or are minimally exposed to the original contaminated media (indirect exposure). The team should decide if the risk assessment should focus on toxicity resulting from direct or indirect exposures, or if both must be evaluated.

Broad assessment endpoints (e.g., protecting aquatic communities) are generally of less value in problem formulation than specific assessment endpoints (e.g., maintaining aquatic

community composition and structure downstream of a site similar to that upstream of the site). Specific assessment endpoints define the ecological value in sufficient detail to identify the measures needed to answer specific questions or to test specific hypotheses. Example 3-3 provides three examples of assessment endpoint selection based on the hypothetical sites in Appendix A.

The formal identification of assessment endpoints is part of the SMDP for this step. Regardless of the level of effort to be expended on the subsequent phases of the risk assessment, the assessment endpoints identified are critical elements in the design of the ecological risk assessment and must be agreed upon as the focus of the risk assessment. Once assessment endpoints have been selected, testable hypotheses and measurement endpoints can be developed to determine whether or not a potential threat to the assessment endpoints exists. Testable hypotheses and measurement endpoints cannot be developed without agreement on the assessment endpoints among the risk manager, risk assessors, and other involved professionals.

3.6 THE CONCEPTUAL MODEL AND RISK QUESTIONS

The site conceptual model establishes the complete exposure pathways that will be evaluated in the ecological risk assessment and the relationship of the measurement endpoints to the assessment endpoints. In the conceptual model, the possible exposure pathways are depicted in an exposure pathway diagram and must be linked directly to the assessment endpoints identified in Section 3.5. Developing the conceptual model and risk questions are described in Sections 3.6.1 and 3.6.2, respectively. Selection of measurement endpoints, completing the conceptual model, is described in Step 4.

3.6.1 Conceptual Model

Based on the information obtained from Steps 1 and 2, knowledge of the contaminants present, the exposure pathway diagram, and the assessment endpoints, an integrated conceptual model is developed (see Example 3-4). The conceptual model includes a contaminant fate-and-transport diagram that traces the contaminants' movement from sources through the ecosystem to receptors that include the assessment endpoints (see Example 3-5). Contaminant exposure pathways that do not lead to a species or group of species associated with the proposed assessment endpoint indicate that either:

- (1) There is an incomplete exposure pathway to the receptor(s) associated with the proposed assessment endpoint; or
- (2) There are missing components or data necessary to demonstrate a complete exposure pathway.

EXAMPLE 3-3

Assessment Endpoint Selection—DDT, Copper, and PCB Sites

DDT Site

An assessment endpoint such as "protection of the ecosystem from the effects of DDT" would give little direction to the risk assessment. However, "protection of piscivorous birds from eggshell thinning due to DDT exposure" directs the risk assessment toward the food-chain transfer of DDT that results in eggshell thinning in a specific group of birds. This assessment endpoint provides the foundation for identifying appropriate measures of effect and exposure and ultimately the design of the site investigation. It is not necessary that a specific species of bird be identified on site. It is necessary that the exposure pathway exists and that the presence of a piscivorous bird could be expected.

Copper Site

Copper can be acutely or chronically toxic to organisms in an aquatic community through direct exposure of the organisms to copper in the water and sediments. Threats of copper toxicity to higher-trophic-level organisms are unlikely to exceed threats to organisms at the base of the food chain, because copper is an essential nutrient which is effectively regulated by most organisms if the exposure is below immediately toxic levels. Aquatic plants (particularly phytoplankton) and mollusks, however, are poor at regulating copper and might be sensitive receptors or effective in transferring copper to the next trophic level. In addition, fish fry can be very sensitive to copper in water. Based on these receptors and the potential for both acute and chronic toxicity, an appropriate general assessment endpoint for the system could be the maintenance of aquatic community composition. An operational definition of the assessment endpoint for this site would be pond fish and invertebrate community composition similar to that of other ponds of similar size and characteristics in the area.

PCB Site

The primary ecological threat of PCBs in ecosystems is not through direct exposure and acute toxicity. Instead, PCBs bioaccumulate in food chains and can diminish reproductive success in some vertebrate species. PCBs have been implicated as a cause of reduced reproductive success of piscivorous birds (e.g., cormorants, terns) in the Great Lakes (Kubiak et al., 1989; Fox et al., 1991) and of mink along several waterways (Aulerich and Ringer, 1977; Foley et al., 1988). Therefore, reduced reproductive success in high-trophic-level species exposed via their diet is a more appropriate assessment endpoint than either toxicity to organisms via direct exposure to PCBs in water, sediments, or soils, or reproductive impairment in lower-trophic-level species.

EXAMPLE 3-4

Description of the Conceptual Model—DDT Site

One of the assessment endpoints selected for the DDT site (Appendix A) is the protection of piscivorous birds. The site conceptual model includes the release of DDT from the spill areas to the adjacent stream, followed by food chain accumulation of DDT from the sediments and water through the lower trophic levels to forage fish in the stream. The forage fish are the exposure point for piscivorous birds. Eggshell thinning was selected as the measure of effect. During the literature review of the ecological effects of DDT, toxicity studies were found that reported reduced reproductive success (i.e., number of young fledged) in birds that experienced eggshell thinning of 20 percent or more (Anderson and Hickey, 1972; Dilworth et al., 1972). Based on those data, the lead risk assessor and risk manager agreed that eggshell thinning of 20 percent or more would be considered an adverse effect for piscivorous birds.

Chronic DDT exposure can also reduce some animals' ability to escape predation. Thus, DDT can indirectly increase the mortality rate of these organisms by making them more susceptible to predators (Cooke, 1971; Krebs et al., 1974). That effect of DDT on prey also can have an indirect consequence for the predators. If predators are more likely to capture the more contaminated prey, the predators could be exposed to DDT at levels higher than represented in the average prey population.

If case (1) is true, the proposed assessment endpoint should be reevaluated to determine if it is an appropriate endpoint for the site. If case (2) is true, then additional field data could be needed to evaluate contaminant fate and transport at the site. Failure to identify a complete exposure pathway that does exist at the site can result in incorrect conclusions or in extra time and effort being expended on a supplementary investigation.

As indicated in Section 3.5, appropriate assessment endpoints differ from site to site, and can be at one or more levels of biological organization. At any particular site, the appropriate assessment endpoints might involve local populations of a particular species, community-level integrity, and/or habitat preservation. The site conceptual model must encompass the level of biological organization appropriate for the assessment endpoints for the site. The conceptual model can use assumptions that generally represent a group of organisms or ecosystem components.

The intent of the conceptual model is not to describe a particular species or site exactly as much as it is to be systematic, representative, and conservative where information is lacking (with assumptions biased to be more likely to overestimate than to underestimate risk). For example, it is not necessary or even recommended to develop new test protocols to use species that exist at a site to test the toxicity of site media (See Step 4). Species used in standardized laboratory toxicity tests (e.g., fathead minnows, *Hyallela* amphipods) usually are adequate surrogates for species in their general taxa and habitat at the site.

EXAMPLE 3-5
Conceptual Model Diagram- DDT Site

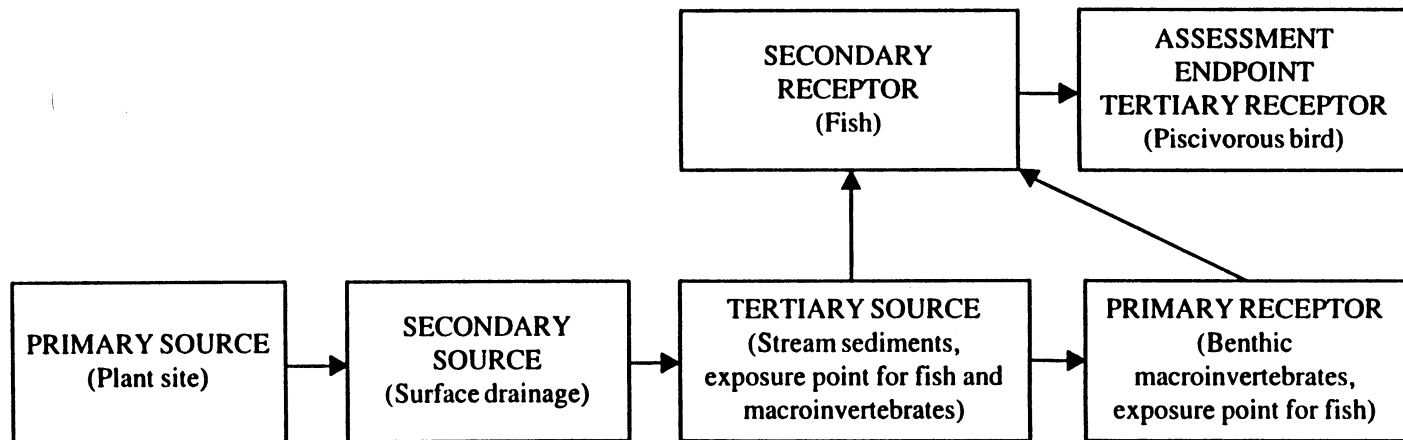

3.6.2 Risk Questions

Ecological risk questions for the baseline risk assessment at Superfund sites are basically questions about the relationships among assessment endpoints and their predicted responses when exposed to contaminants. The risk questions should be based on the assessment endpoints and provide a basis for developing the study design (Step 4) and for evaluating the results of the site investigation in the analysis phase (Step 6) and during risk characterization (Step 7).

The most basic question applicable to virtually all Superfund sites is whether site-related contaminants are causing or have the potential to cause adverse effects on the assessment endpoint(s). To use the baseline ecological risk assessment in the FS to evaluate remedial alternatives, it is helpful if the specific contaminant(s) responsible can be identified. Thus refined, the question becomes "does (or could) chemical X cause adverse effects on the assessment endpoint?" In general, there are four lines of evidence that can be used to answer this question:

- (1) Comparing estimated or measured exposure levels to chemical X with levels that are known from the literature to be toxic to receptors associated with the assessment endpoints;
- (2) Comparing laboratory bioassays with media from the site and bioassays with media from a reference site;
- (3) Comparing *in situ* toxicity tests at the site with *in situ* toxicity tests in a reference body of water; and
- (4) Comparing observed effects in the receptors associated with the site with similar receptors at a reference site.

These lines of evidence are considered further in Step 4, as measurement endpoints are selected to complete the conceptual model and the site-specific study is designed.

HIGHLIGHT 3-3

Definitions: Null and Test Hypotheses

Null hypothesis: Usually a hypothesis of no differences between two populations formulated for the express purpose of being rejected.

Test (or alternative) hypothesis: An operational statement of the investigator's research hypothesis.

When appropriate, formal hypothesis testing is preferred to make explicit what error rates are acceptable and what magnitude of effect is considered biologically important. However, it might not be practical for many assessment endpoints or be the only acceptable way to state questions about those endpoints. See Example 4-1 in the next chapter.

3.7 SCIENTIFIC/MANAGEMENT DECISION POINT (SMDP)

At the conclusion of Step 3, there is a SMDP. The SMDP consists of agreement on four items: contaminants of concern, assessment endpoints, exposure pathways, and risk questions. Those items can be summarized with the assistance of the diagram of the conceptual model. Without agreement between the risk manager, risk assessors, and other involved professionals on the conceptual model to this point, measurement endpoints cannot be selected, and a site study cannot be developed effectively. Example 3-5 shows the conceptual model for the DDT site example in Appendix A.

3.8 SUMMARY

By combining information on: (1) the potential contaminants present; (2) the ecotoxicity of the contaminants; (3) environmental fate and transport; (4) the ecological setting; and (5) complete exposure pathways, an evaluation is made of what aspects of the ecosystem at the site could be at risk and what the adverse ecological response could be. "Critical exposure pathways" are based on: (1) exposure pathways to sensitive species' populations or communities; and (2) exposure levels associated with predominant fate and transport mechanisms at a site.

Based on that information, the risk assessors and risk manager agree on assessment endpoints and specific questions or testable hypotheses that, together with the rest of the conceptual model, form the basis for the site investigation. At this stage, site-specific information on exposure pathways and/or the presence of specific species is likely to be incomplete. By using the conceptual model developed thus far, measurement endpoints can be selected, and a plan for filling information gaps can be developed and written into the ecological WP and SAP as described in Step 4.

STEP 4: STUDY DESIGN AND DATA QUALITY OBJECTIVE PROCESS

OVERVIEW

The site conceptual model begun in Step 3, which includes assessment endpoints, exposure pathways, and risk questions or hypotheses, is completed in Step 4 with the development of measurement endpoints. The conceptual model then is used to develop the study design and data quality objectives. The products of Step 4 are the ecological risk assessment WP and SAP, which describe the details of the site investigation as well as the data analysis methods and data quality objectives (DQOs). As part of the DQO process, the SAP specifies acceptable levels of decision errors that will be used as the basis for establishing the quantity and quality of data needed to support ecological risk management decisions.

The lead risk assessor and the risk manager should agree that the WP and SAP describe a study that will provide the risk manager with the information needed to fulfill the requirements of the baseline risk assessment and to incorporate ecological considerations into the site remedial process. Once this step is completed, most of the professional judgment needed for the ecological risk assessment will have been incorporated into the design and details of the WP and SAP. This does not limit the need for qualified professionals in the implementation of the investigation, data acquisition, or data interpretation. However, there should be no fundamental changes in goals or approach to the ecological risk assessment once the WP and SAP are finalized.

It is important to coordinate this step with the WP and SAP for the site investigation, which is used to document the nature and extent of contamination and to evaluate human health risks.

Step 4 of the ecological risk assessment establishes the measurement endpoints (Section 4.1), completing the conceptual model begun in Step 3. Step 4 also establishes the study design (Section 4.2) and data quality objectives based on statistical considerations (Section 4.3) for the site assessment that will accompany site-specific studies for the remedial investigation. The site conceptual model is used to identify which points or assumptions in the risk assessment include the greatest degree of conservatism or uncertainty. The field sampling then can be designed to address the risk model parameters that have important effects on the risk estimates (e.g., bioavailability and toxicity of contaminants in the field, contaminant concentrations at exposure points).

The products of Step 4 are the WP and SAP for the ecological component of the field investigations (Section 4.4). Involvement of the BTAG in the preparation, review, and approval of WPs and SAPs can help ensure that the ecological risk assessment is well focused, performed efficiently, and technically correct.

The WP and SAP should specify the site conceptual model developed in Step 3, and the measurement endpoints developed in the beginning of Step 4. The WP describes:

- Assessment endpoints;
- Exposure pathways;
- Questions and testable hypotheses;
- Measurement endpoints and their relation to assessment endpoints; and
- Uncertainties and assumptions.

The SAP should describe:

- Data needs;
- Scientifically valid and sufficient study design and data analysis procedures;
- Study methodology and protocols, including sampling techniques;
- Data reduction and interpretation techniques, including statistical analyses; and
- Quality assurance procedures and quality control techniques.

The SAP must include the data reduction and interpretation techniques, because it is necessary to know how the data will be interpreted to specify the number of samples needed.

Prior to formal agreement on the WP and SAP, the proposed field sampling plan is verified in Step 5.

4.1 ESTABLISHING MEASUREMENT ENDPOINTS

As indicated in the Introduction, a measurement endpoint is defined as "a measurable ecological characteristic that is related to the valued characteristic chosen as the assessment endpoint" and is a measure of biological effects (e.g., mortality, reproduction, growth) (U.S. EPA, 1992a; although this definition may change—see U.S. EPA 1996a). Measurement endpoints are frequently numerical expressions of observations (e.g., toxicity test results, community diversity measures) that can be compared statistically to a control or reference site to detect adverse responses to a site contaminant. As used in this guidance, measurement endpoints can include measures of exposure (e.g., contaminant concentrations in water) as well as measures of effect. The relationship between measurement and assessment endpoints must be clearly described within the conceptual model and must be based on scientific evidence. This is critical because the assessment and measurement endpoints usually are different endpoints (see the Introduction and Highlight 4-1).

Typically, the number of measurement endpoints that are potentially appropriate for any given assessment endpoint and circumstance is limited. The most appropriate measurement endpoints for an assessment endpoint depend on several considerations, a primary one being how many and which lines of evidence are needed to support risk-management decisions at the site (see Section 3.6.2). Given the potential ramifications of site actions, the site risk manager might want to use more than one line of evidence to identify site-specific thresholds for effects. The risk manager and risk assessors must consider the utility of each type of data given the cost of collecting those data and the likely sensitivity of the risk estimates to the data.

HIGHLIGHT 4-1 Importance of Distinguishing Measurement from Assessment Endpoints

If a measurement endpoint is mistaken for an assessment endpoint, the misperception can arise that Superfund is basing a remediation on an arbitrary or esoteric justification. For example, protection of a few invertebrate and algal species could be mistaken as the basis for a remedial decision, when the actual basis for the decision is the protection of the aquatic community as a whole (including higher-trophic-level game fish that depend on lower trophic levels in the community), as indicated by a few sensitive invertebrate and algal species.

There are some situations in which it might only be necessary or possible to compare estimated or measured contaminant exposure levels at a site to ecotoxicity values derived from the literature. For example, for contaminants in surface waters for which there are state water-quality standards, exceedance of the standards indicates that remediation to reduce contaminant concentrations in surface waters to below these levels could be needed whether impacts are occurring or not. For assessment endpoints for which impacts are difficult to demonstrate in the field (e.g., because of high natural variability), and toxicity tests are not possible (e.g., food-chain accumulation is involved), comparing environmental concentrations with a well-supported ecotoxicity value might have to suffice.

A bioassay using contaminated media from the site can suffice if the risk manager and risk assessor agree that laboratory tests with surrogate species will be taken as indicative of likely effects on the assessment endpoint. For sites with complex mixtures of contaminants without robust ecotoxicity values and high natural variability in potential measures for the assessment endpoint, either laboratory or *in situ* toxicity testing might be the best technique for evaluating risks to the assessment endpoint. For inorganic substances in soils or sediments, bioassays often are needed to determine the degree to which a contaminant is bioavailable at a particular site. Laboratory toxicity tests can indicate the potential for adverse impacts in the field, while *in situ* toxicity testing with resident organisms can provide evidence of actual impacts occurring in the field.

Sometimes more than one line of evidence is needed to reasonably demonstrate that contaminants from a site are likely to cause adverse effects on the assessment endpoint. For

example, total recoverable copper in a surface water body to which a water quality standard did not apply could exceed aquatic ecotoxicity values, but not cause adverse effects because the copper is only partially bioavailable or because the ecotoxicity value is too conservative for the particular ecosystem. Additional evidence from bioassays or community surveys could help resolve whether the copper is actually causing adverse effects (See Example 4-1). Alternatively, if stream community surveys indicate impairment of community structure downstream of a site, comparing contaminant concentrations with aquatic toxicity values can help identify which contaminants are most likely to be causing the effect. When some lines of evidence conflict with others, professional judgment is needed to determine which data should be considered more reliable or relevant to the questions.

EXAMPLE 4-1 **Lines of Evidence—Copper Site**

Primary question: Are ambient copper levels in sediments causing adverse effects in benthic organisms in the pond?

Possible lines of evidence phrased as test hypotheses:

- (1) Mortality in early life stages of benthic aquatic insects in contact with sediments from the site significantly exceeds mortality in the same kinds of organisms in contact with sediments from a reference site (e.g., $p \leq 0.1$).
- (2) Mortality in *in situ* toxicity tests in sediments at the pond significantly exceeds mortality in *in situ* toxicity tests in sediments at a reference pond (e.g., $p \leq 0.1$).
- (3) There are significantly fewer numbers of benthic aquatic insect species present per m^2 of sediment at the pond near the seep than at the opposite side of the pond (e.g., $p \leq 0.1$).

Statistical and biological significance: Differences in the incidence of adverse effects between groups of organisms exposed to contaminants from the site and groups not exposed might be statistically significant, but not biologically important, depending on the endpoint and the power of the statistical test. Natural systems can sustain some level of perturbation without changing in structure or function. The risk assessor needs to evaluate what level of effect will be considered biologically important. Given the limited power of small sample sizes to detect an effect, the risk assessor might decide that any difference that is statistically detectable at a p level of 0.1 or less is important biologically.

Once there is agreement on which lines of evidence are required to answer questions concerning the assessment endpoint, the measurement endpoints by which the questions or test hypotheses will be examined can be selected.

Each measurement endpoint should represent the same exposure pathway and toxic mechanism of action as the assessment endpoint it represents; otherwise, irrelevant exposure pathways or toxic mechanisms might be evaluated. For example, if a contaminant primarily causes damage to vertebrate kidneys, the use of daphnids (which do not have kidneys) would be inappropriate.

Potential measurement endpoints in toxicity tests or in field studies should be evaluated according to how well they can answer questions about the assessment endpoint or support or refute the hypotheses developed for the conceptual model. Statistical considerations, including sample size and statistical power described in Section 4.3, also must be considered in selecting the measurement endpoints. The following subsections describe additional considerations for selecting measurement endpoints, including species/community/habitat (Section 4.1.1), relationship to the contaminant(s) of concern (Section 4.1.2), and mechanisms of ecotoxicity (Section 4.1.3).

4.1.1 Species/Community/Habitat Considerations

The function of a measurement endpoint is to represent an assessment endpoint for the site. The measurement endpoint must allow clear inferences about potential changes in the assessment endpoint. Whenever assessment and measurement endpoints are not the same (which usually is the case), measurement endpoints should be selected to be inclusive of risks to all of the species, populations, or groups included in the assessment endpoint that are not directly measured. In other words, the measurement endpoint should be representative of the assessment endpoint for the site and not lead to an underestimate of risk to the assessment endpoint. Example 4-2 illustrates this point for the DDT site in Appendix A.

In selecting a measurement endpoint, the species and life stage, population, or community chosen should be the one(s) most susceptible to the contaminant for the assessment endpoint in question. For species and populations, this selection is based on a review of the species: (1) life history; (2) habitat utilization; (3) behavioral characteristics; and (4) physiological parameters. Selection of measurement endpoints also should be based on which routes of exposure are likely. For communities, careful evaluation of the contaminant fate and transport in the environment is essential.

4.1.2 Relationship of the Measurement Endpoints to the Contaminant of Concern

Additional criteria to consider when selecting measurement endpoints are inherent properties (such as the physiology or behavioral characteristics of the species) or life history parameters that make a species useful in evaluating the effects of site-specific contaminants.

HIGHLIGHT 4-2 Terminology and Definitions

In the field of ecotoxicology, there historically have been multiple definitions for some terms, including definitions for direct effects, indirect effects, acute effects, chronic effects, acute tests, and chronic tests. This multiplicity of definitions has resulted in misunderstandings and inaccurate communication of study designs. Definitions of these and other terms, as they are used in this document, are provided in the glossary. When consulting other reference materials, the user should evaluate how the authors defined terms.

For example, *Chironomus tentans* (a species of midge that is used as a standard sediment toxicity testing species in the larval stage) is considered more tolerant of metals contamination than is *C. riparius*, a similar species (Klemm et al., 1990; Nebeker et al., 1984; Pascoe et al., 1989). To assess the effects of exposure of benthic communities to metal-contaminated sediment, *C. riparius* might be the better species to use as a test organism for many aquatic systems to ensure that risks are not underestimated. In general, the most sensitive of the measurement endpoints appropriate for inferring risks to the assessment endpoint should be used. If

all else is equal, however, species that are commonly used in the laboratory are preferred over non-standard laboratory species to improve test precision.

Some species have been identified as being particularly sensitive to certain contaminants. For example, numerous studies have demonstrated that mink are among the most sensitive of the tested mammalian species to the toxic effects of PCBs (U.S. EPA, 1995a). Species that rely on quick reactions or behavioral responses to avoid predators can be particularly sensitive to contaminants affecting the central nervous system, such as mercury. Thus, the sensitivity of the measurement endpoint relative to the assessment endpoint should be considered for each contaminant of concern.

EXAMPLE 4-2 Selecting Measurement Endpoints- DDT Site

As described in Example 3-1, one of the assessment endpoints selected for the DDT site is the protection of piscivorous birds from egg-shell thinning due to DDT exposure. The belted kingfisher was selected as a piscivorous bird with the smallest home range that could utilize the area of the site, thereby maximizing the calculated dose to a receptor. In this illustration, the kingfishers are used as the most highly exposed of the piscivorous birds potentially present. Thus, one can conclude that, if the risk assessment shows no threat of eggshell thinning to the kingfisher, there should be minimal or no threat to other piscivorous birds that might utilize the site. Thus, eggshell thinning in belted kingfishers is an appropriate measurement endpoint for this site.

4.1.3 Mechanisms of Ecotoxicity

A contaminant can exert adverse ecological effects in many ways. First, a contaminant might affect an organism after exposure for a short period of time (acute) or after exposure over an extended period of time (chronic). Second, the effect of a contaminant could be lethal (killing the organism) or sublethal (causing adverse effects other than death, such as reduced growth, behavioral changes, etc.). Sublethal effects can reduce an organism's lifespan or reproductive success. For example, if a contaminant reduces the reaction speed of a prey species, the prey can become more susceptible to predation. Third, a contaminant might act directly or indirectly on an organism. Direct effects include lethal or sublethal effects of the chemical on the organism. Indirect effects occur when the contaminant damages the food, habitat, predator-prey relationships, or competition of the organism in its community.

Mechanisms of ecotoxicity and exposure pathways have already been considered during problem formulation and identification of the assessment endpoints. However, toxicity issues are revisited when selecting appropriate measurement endpoints to ensure that they measure the assessment endpoint's toxic response of concern.

4.2 STUDY DESIGN

In Section 4.1, one or more lines of evidence that could be used to answer questions or to test hypotheses concerning the assessment endpoint(s) were identified. This section provides recommendations on how to design a field study for: bioaccumulation and field tissue residue studies (Section 4.2.1); population/community evaluations (Section 4.2.2); and toxicity testing (Section 4.2.3). A thorough understanding of the strengths and limitations of these types of field studies is necessary to properly design any investigation.

Typically, no one line of evidence can stand on its own. Analytic chemistry on co-located samples and other lines of evidence are needed to support a conclusion. When population/community evaluations are coupled with toxicity testing and media chemistry, the procedure often is referred to as a triad approach (Chapman et al., 1992; Long and Chapman, 1985). This method has proven effective in defining the area affected by contaminants in sediments of several large bays and estuaries.

The development of exposure-response relationships is critical for evaluating risk management options; thus, for all three types of studies, sampling is applied to a contamination gradient when possible as well as compared to reference data. Reference data are baseline values or characteristics that should represent the site in the absence of contaminants released from the site. Reference data might be data collected from the site before contamination occurred or new data collected from a reference site. The reference site can be the least impacted (or unimpacted) area of the Superfund site or a nearby site that is

ecologically similar, but not affected by the site's contaminants. For additional information on selecting and using reference information in Superfund ecological risk assessments, see *ECO Update Volume 2, Number 1* (U.S. EPA, 1994e).

The following subsections present a starting point for selecting an appropriate study design for the different types of biological sampling that might apply to the site investigation.

4.2.1 Bioaccumulation and Field Tissue Residue Studies

Bioaccumulation and field tissue residue studies typically are conducted at sites where contaminants are likely to accumulate in food chains. The studies help to evaluate contaminant exposure levels associated with measures of effect for assessment endpoint species.

The degree to which a contaminant is transferred through a food chain can be evaluated in several ways. The most common type of study reported in the literature is a contaminant bioaccumulation (uptake) study. As indicated in Section 2.2.1, the most conservative BAF values identified in the literature generally are used to estimate bioaccumulation in Step 2 of the screening-level risk assessment. Where the potential for overestimating bioaccumulation by using conservative literature values to represent the site is substantial, additional evaluation of the literature for values more likely to apply to the site or a site-specific tissue residue study might be advisable.

A tissue residue study generally is conducted on organisms that are in the exposure pathway (i.e., food chain) associated with the assessment endpoint. Data seldom are available to link tissue residue levels in the sampled organisms to adverse effects in those organisms. Literature toxicity studies usually associate effects with an administered dose (or data that can be converted to an administered dose), not a tissue residue level. Thus, the purpose of a field tissue residue study usually is to measure contaminant concentrations in foods consumed by the species associated with the assessment endpoint. This measurement minimizes the uncertainty associated with estimating a dose (or intake) to that species, particularly in situations in which several media and trophic levels are in the exposure pathway.

The concentration of a contaminant in the primary prey/food also should be linked to an exposure concentration from a contaminated medium (e.g., soil, sediment, water), because it is the medium, not the food chain, that will be remediated. Thus, contaminant concentrations must be measured in environmental media at the same locations at which the organisms are collected along contaminant gradients and at reference locations. Co-located samples of the contaminated medium and organisms are needed to establish a correlation between the tissue residue levels and contamination levels in the medium under evaluation; these studies are most effective if conducted over a gradient of contaminant concentrations. In addition, tissue residues from sessile organisms (e.g., rooted plants, clams) are easier to attribute to specific contaminated areas than are tissue residues from mobile organisms (e.g.,

large fish). Example 4-3 illustrates these concepts using the DDT site example in Appendix A.

EXAMPLE 4-3
Tissue Residue Studies—DDT Site

In the DDT site example, a forage fish (e.g., creek chub) will be collected at several locations with known DDT concentrations in sediments. The forage fish will be analyzed for body burdens of DDT, and the relationship between the DDT levels in the sediments and the levels in the forage fish will be established. The forage fish DDT concentrations can be used to evaluate the DDT threat to piscivorous birds feeding on the forage fish at each location. Using the DDT concentrations measured in fish that correspond to a LOAEL and NOAEL for adverse effects in birds and the relationship between the DDT levels in the sediments and in the forage fish, the corresponding sediment contamination levels can be estimated. Those sediment DDT concentrations can then be used to estimate a cleanup level that would reduce threats of eggshell thinning to piscivorous birds.

Although it might seem obvious, it is important to confirm that the organisms examined for tissue residue levels are in the exposure pathways of concern established by the conceptual model. Food items targeted for collection should be those that are likely to constitute a large portion of the diet of the species of concern (e.g., new growth on maple trees, rather than cattails, as a food source for deer) and/or represent pathways of maximum exposure. If not, erroneous conclusions or study delays and added costs can result. Because specific organisms often can only be captured in one season, the timing of the study can be critical, and failure to plan accordingly can result in serious site management difficulties.

There are numerous factors that must be considered when selecting a species in which to measure contaminant residue levels. Several investigators have discussed the "ideal" characteristics of the species to be collected and analyzed. The recommendations of Phillips (1977, 1978) include that the species selected should be:

- (1) Able to accumulate the chemical of concern without being adversely affected by the levels encountered at the site;
- (2) Sedentary (small home range) in order to be representative of the area of collection;
- (3) Abundant in the study area; and

- (4) Of reasonable size to give adequate tissue for analysis (e.g., 10 grams for organic analysis and 0.5 gram for metal analysis for many laboratories (Roy F. Weston, Inc., 1994)).

Additional considerations for some situations would be that the species is:

- (5) Sufficiently long-lived to allow for sampling more than one age class; and
- (6) Easy to sample and hardy enough to survive in the laboratory (allowing for the organisms to eliminate contaminants from their gastrointestinal tract prior to analysis, if desired, and allowing for laboratory studies on the uptake of the contaminant).

It is usually not possible or necessary to find an organism that fulfills all of the above requirements. The selection of an organism for tissue analysis should balance these characteristics with the hypotheses being tested, knowledge of the contaminants' fate and transport, and the practicality of using the particular species. In the following sections, several of the factors mentioned above are described in greater detail.

Ability to accumulate the contaminant. The objectives of a tissue residue study are (1) to measure bioavailability directly; (2) to provide site-specific estimates of exposure to higher-trophic-level organisms; and (3) to relate tissue residue levels to concentrations in environmental media (e.g., in soil, sediment, or water). Sometimes these studies also can be used to link tissue residue levels with observed effects in the organisms sampled. However, in a "pure" accumulation study, the species selected for collection and tissue analysis should be ones that can accumulate a contaminant(s) without being adversely affected by the levels encountered in the environment. While it is difficult to evaluate whether or not a population in the field is affected by accumulation of a contaminant, it is important to try. Exposure that results in adverse responses might alter the animal's feeding rates or efficiency, diet, degree of activity, or metabolic rate, and thereby influence the animal's daily intake or accumulation of the contaminant and the estimated BAF. For example, if the rate of bioaccumulation of a contaminant in an organism decreases with increasing environmental concentrations (e.g., its toxic effects reduce food consumption rates), using a BAF determined at low environmental concentrations to estimate bioaccumulation at high environmental concentrations would overestimate risk. Conversely, if bioaccumulation increased with increasing environmental concentrations (e.g., its toxic effects impair the organisms' ability to excrete the contaminant), using a BAF determined at low environmental concentrations would underestimate risks at higher environmental concentrations.

Consideration of the physiology and biochemistry of the species selected for residue analysis also is important. Some species can metabolize certain organic contaminant(s) (e.g., fish can metabolize PAHs). If several different types of prey are consumed by a species of concern, it would be more appropriate to analyze prey species that do not metabolize the contaminant.

Home range. When selecting species for residue analyses, one should be confident that the contaminant levels found in the organism depend on the contaminant levels in the environmental media under evaluation. Otherwise, valid conclusions cannot be drawn about ecological risks posed by contaminants at the site. The home range, particularly the foraging areas within the home range, and movement patterns of a species are important in making this determination. Organisms do not utilize the environment uniformly. For species that have large home ranges or are migratory, it can be difficult to evaluate potential exposure to contaminants at the site. Attribution of contaminant levels in an organism to contaminant levels in the surrounding environment is easiest for animals with small home and foraging ranges and limited movement patterns. Examples of organisms with small home ranges include young-of-the-year fish, burrowing crustacea (such as fiddler crabs or some crayfish), and small mammals.

Species also should be selected for residue analysis to maximize the overlap between the area of contamination and the species' home range or feeding range. This provides a conservative evaluation of potential exposure levels. The possibility that a species' preferred foraging areas within a home range overlap the areas of maximum contamination also should be considered.

Population size. A species selected for tissue residue analysis should be sufficiently abundant at the site that adequate numbers (and sizes) of individuals can be collected to support the tissue mass requirements for chemical analysis and to achieve the sample size needed for statistical comparisons. The organisms actually collected should be not only of the same species, but also of similar age or size to reduce data variability when BAFs are being evaluated. The practicality of using a particular species is evaluated in Step 5.

Size/composites. When selecting species in which to measure tissue residue levels, it is best to have individual animals large enough for chemical analysis, without having to pool (combine) individuals prior to chemical analysis. However, composite samples will be needed if individuals from the species selected cannot yield sufficient tissue for the required analytical methods. Linking contaminant levels in organisms to concentrations in environmental media is easier if composites are made up of members of the same species, sex, size, and age, and therefore exhibit similar accumulation characteristics. When deciding whether or not to pool samples, it is important to consider what impact the loss of information on variability of contaminant levels along these dimensions will have on data interpretation. The size, age, and sex of the species collected should be representative of the range of prey consumed by the species of concern.

Summary. Although it can be difficult to meet all of the suggested criteria for selecting a species for tissue residue studies, an attempt should be made to meet as many criteria as possible. No formula is available for ranking the factors in order of importance within a particular site investigation because the ranking depends on the study objectives. However, a key criterion is that the organism be sedentary or have a limited home range. It is difficult to connect site contamination to organisms that migrate over great distances or that

have extremely large home ranges. Further information on factors that can influence bioaccumulation is available from the literature (e.g., Phillips, 1977, 1978; U.S. EPA, 1995d).

4.2.2 Population/Community Evaluations

Population/community evaluations, or biological field surveys, are potentially useful for both contaminants that are toxic to organisms through direct exposure to the contaminated medium and contaminants that bioaccumulate in food chains. In either case, careful consideration must be given to the mechanism of contaminant effects. Since population/community evaluations are "impact" evaluations, they typically are not predictive. The release of the contaminant must already have occurred and exerted an effect in order for the population/community evaluation to be an effective tool for a risk assessment.

Population and community surveys evaluate the current status of an ecosystem, often using several measures of population or community structure (e.g., standing biomass, species richness) or function (e.g., feeding group analysis). The most commonly used measures include number of species and abundance of organisms in an ecosystem, although some species are difficult to evaluate. It is difficult to detect changes in top predator populations affected by bioaccumulation of substances in their food chain due to the mobility of top predators. Some species, most notably insects, can develop a tolerance to contaminants (particularly pesticides); in these cases, a population/community survey would be ineffective for evaluating existing impacts. While population/community evaluations can be useful, the risk assessors should consider the level of effort required as well as the difficulty in accounting for natural variability.

A variety of population/community evaluations have been used at Superfund sites. Benthic macroinvertebrate surveys are the most commonly conducted population/community evaluations. There are methods manuals (e.g., U.S. EPA 1989c, 1990a) and publications that describe the technical procedures for conducting these studies. In certain instances, fish community evaluations have proven useful at Superfund sites. However, these investigations typically are more labor-intensive and costly than a comparable macroinvertebrate study. In addition, fish generally are not sensitive measures of the effects of sediment contamination, because they usually are more mobile than benthic macroinvertebrates. Terrestrial plant community evaluations have been used to a limited extent at Superfund sites. For those surveys, it is important to include information about historical land use and physical habitat disruption in the uncertainty analysis.

Additional information on designing field studies and on field study methods can be found in *ECO Update Volume 2, Number 3* (U.S. EPA, 1994d).

Although population- and community-level studies can be valuable, several factors can confound the interpretation of the results. For example, many fish and small mammal populations normally cycle in relation to population density, food availability, and other factors. Vole populations have been known to reach thousands of individuals per acre and

then to decline to as low as tens of individuals per acre the following years without an identifiable external stressor (Geller, 1979). It is important that the "noise of the system" be evaluated so that the impacts attributed to chemical contamination at the site are not actually the result of different, "natural" factors. Populations located relatively close to each other can be affected independently: one might undergo a crash, while another is peaking. Physical characteristics of a site can isolate populations so that one population level is not a good indicator of another; for example, a paved highway can be as effective a barrier as a river, and populations on either side can fluctuate independently. Failure to evaluate such issues can result in erroneous conclusions. The level of effort required to resolve some of these issues can make population/community evaluations impractical in some circumstances.

4.2.3 Toxicity Testing

The bioavailability and toxicity of site contaminants can be tested directly with toxicity tests. As with other methods, it is critical that the media tested are in exposure pathways relevant to the assessment endpoint. If the site conceptual model involves exposure of benthic invertebrates to contaminated sediments, then a solid-phase toxicity test using contaminated sediments (as opposed to a water-column exposure test) and an infaunal species would be appropriate. As indicated earlier, the species tested and the responses measured must be compatible with the mechanism of toxicity. Some common site contaminants are not toxic to most organisms at the same environmental concentrations that threaten top predators because the contaminant biomagnifies in food chains (e.g., PCBs); toxicity tests using contaminated media from the site would not be appropriate for evaluating this type of ecological threat.

There are numerous U.S. EPA methods manuals and ASTM guides and procedures for conducting toxicity tests (see references in the Bibliography). While documented methods exist for a wide variety of toxicity tests, particularly laboratory tests, the risk assessor must evaluate what a particular toxicity test measures and, just as importantly, what it does not measure. Questions to consider when selecting an appropriate toxicity test include:

- (1) What is the mechanism of toxicity of the contaminant(s)?
- (2) What contaminated media are being evaluated (water, soil, sediment)?
- (3) What toxicity test species are available to test the media being evaluated?
- (4) What life stage of the species should be tested?
- (5) What should the duration of the toxicity test be?
- (6) Should the test organisms be fed during the test?
- (7) What endpoints should be measured?

There are a limited number of toxicity tests that are readily available for testing environmental media. Many of the aquatic toxicity tests were developed for the regulation of aqueous discharges to surface waters. These tests are useful, but one must consider the original purpose of the test.

New toxicity tests are being developed continually and can be of value in designing a Superfund site ecological risk assessment. However, when non-standard tests are used, complete documentation of the specific test procedures is necessary to support use of the data.

In situ toxicity tests involve placing organisms in locations that might be affected by site contaminants and in reference locations. Non-native species should not be used, because of the risk of their release into the environment in which they could adversely affect (e.g., prey on or outcompete) resident species. *In situ* tests might provide more realistic evidence of existing adverse effects than laboratory toxicity tests; however, the investigator has little control over many environmental parameters and the experimental organisms can be lost to adverse weather or other events (e.g., human interference) at the site or reference location.

For additional information on using toxicity tests in ecological risk assessments, see *ECO Update Volume 2, Numbers 1 and 2* (U.S. EPA, 1994b,c).

4.3 DATA QUALITY OBJECTIVES AND STATISTICAL CONSIDERATIONS

The SAP indicates the number and location of samples to be taken, the number of replicates for each sampling location, and the method for determining sampling locations. In specifying those parameters, the investigator needs to consider, among other things, the DQOs and statistical methods that will be used to analyze the data.

4.3.1 Data Quality Objectives

The DQO process represents a series of planning steps that can be employed throughout the development of the WP and SAP to ensure that the type, quantity, and quality of environmental data to be collected during the ecological investigation are adequate to support the intended application. Problem formulation in Steps 3 and 4 is essentially the DQO process. By employing problem formulation and the DQO process, the investigator is able to define data requirements and error levels that are acceptable for the investigation prior to the collection of data. This approach helps ensure that results are appropriate and defensible for decision making. The specific goals of the general DQO process are to:

- Clarify the study objective and define the most appropriate types of data to collect;
- Determine the most appropriate field conditions under which to collect the data; and

- Specify acceptable levels of decision errors that will be used as the basis for establishing the quantity and quality of data needed to support risk management decisions.

As the discussion of Steps 3 and 4 indicates, those goals are subsumed in the problem formulation phase of an ecological risk assessment. Several U.S. EPA publications provide detailed descriptions of the DQO process (U.S. EPA, 1993c,d,f, 1994f). Because many of the steps of the DQO process are already covered during problem formulation, the DQO process should be reviewed by the investigator and applied as needed.

4.3.2 Statistical Considerations

Sampling locations can be selected "randomly" to characterize an area or non-randomly, as along a contaminant concentration gradient. The way in which sampling locations are selected determines which statistical tests, if any, are appropriate for evaluating test hypotheses.

If a toxicity test is to be used to identify contaminant concentrations in the environment associated with a threshold for adverse effects, the statistical power of the test is important. The threshold for effects is assumed to be between the NOAEL and LOAEL of a toxicity test (see Section 7.3.1). For toxicity tests that use a small number of test and control organisms or for which the toxic response is highly variable, the increase in response rate of the test animals compared with controls often must be relatively high (e.g., 30 to 50 percent increase) for the response to be considered a LOAEL (i.e., statistically increased level of an adverse response compared with control levels). If a NOAEL-to-LOAEL range that might represent a 20 to 50 percent increase in adverse effect is unacceptable (e.g., a population is unlikely to sustain itself with an additional 40 percent mortality), then the power of the study design must be increased, usually by increasing sample size, but sometimes by taking full advantage of all available information to improve the power of the design (e.g., stratified sampling, special tests for trends, etc.). A limitation on the use of toxicity values from the literature is that often, the investigator does not discuss the statistical power of the study design, and hence does not indicate the minimum statistically detectable effect level. Appendix D describes additional statistical considerations, including a description of Type I and Type II error, statistical power, statistical models, and power efficiency.

In evaluating the results of statistical analyses, one should remember that a statistically significant difference relative to a control or reference population does not necessarily imply a biologically important or ecologically significant difference (see Example 4-1).

4.4 CONTENTS OF WORK PLAN AND SAMPLING AND ANALYSIS PLAN

The WP and SAP for the ecological investigation should be developed as part of the initial RI sampling event if possible. If not, the WP and SAP can be developed as an

additional phase of the site investigation. In either case, the format of the WP and SAP should be similar to that described by U.S. EPA (1988a, 1989b). Accordingly, those documents should be consulted when developing the ecological investigation WP and SAP.

The WP and SAP are typically written as separate documents. In that case, the WP can be submitted for the risk manager's review so that any concerns with the approach can be resolved prior to the development of the SAP. For some smaller sites, it might be more practical to combine the two documents, in which case, the investigators should discuss the overall objectives and approach with the risk manager to ensure that all parties agree.

The WP and SAP are briefly described in Sections 4.4.1 and 4.4.2, respectively. A plan for testing the SAP before the site WP and SAP are signed and the investigation begins is described in Section 4.4.3.

4.4.1 Work Plan

The purpose of the WP is to document the decisions and evaluations made during problem formulation and to identify additional investigative tasks needed to complete the evaluation of risks to ecological resources. As presented in U.S. EPA (1988a), the WP generally includes the following:

- A general overview and background of the site including the site's physical setting, ecology, and previous uses;
- A summary and analysis of previous site investigations and conclusions;
- A site conceptual model, including an identification of the potential exposure pathways selected for analysis, the assessment endpoints and questions or testable hypotheses, and the measurement endpoints selected for analysis;
- The identification of additional site investigations needed to conduct the ecological risk assessment; and
- A description of assumptions used and the major sources of uncertainty in the site conceptual model and existing information.

The general scope of the additional sampling activities also is presented in the WP. A detailed description of the additional sampling activities is presented in the SAP along with an anticipated schedule of the site activities.

4.4.2 Sampling and Analysis Plan

The SAP typically consists of two components: a field sampling plan (FSP) and a quality assurance project plan (QAPP). The FSP provides guidance for all field work by

providing a detailed description of the sampling and data-gathering procedures to be used for the project. The QAPP provides a description of the steps required to achieve the objectives dictated by the intended use of the data.

Field sampling plan. The FSP provides a detailed description of the samples needed to meet the objectives and scope of the investigation outlined in the WP. The FSP for the ecological assessment should be detailed enough that a sampling team unfamiliar with the site would be able to gather all the samples and/or required field data based on the guidelines presented in the document. The FSP for the ecological investigation should include a description of the following elements:

- Sampling type and objectives;
- Sampling location, timing, and frequency;
- Sample designation;
- Sampling equipment and procedures; and
- Sample handling and analysis.

A detailed description of those elements for chemical analyses is provided in Appendix B of U.S. EPA (1988a). Similar specifications should be developed for the biological sampling.

Quality assurance project plan. The objective of the QAPP is to provide a description of the policy, organization, functional activities, and quality control protocols necessary for achieving the study objectives. Highlight 4-3 presents the elements typically contained in a QAPP.

U.S. EPA has prepared guidance on the contents of a QAPP (U.S. EPA, 1987a, 1988a, 1989a). Formal quality assurance and quality control (QA/QC) procedures exist for some types of ecological assessments, for example, for laboratory toxicity tests on aquatic species. For standardized laboratory tests, there are formal QA/QC procedures that specify (1) sampling and handling of hazardous wastes; (2) sources and culturing of test organisms; (3) use of reference toxicants, controls, and exposure replicates; (4) instrument calibration; (5) record keeping; and (6) data evaluation. For other types of ecological assessments, however, QA/QC procedures are less well defined (e.g., for biosurveys of vegetation, terrestrial vertebrates). BTAG

HIGHLIGHT 4-3 Elements of a QAPP

- (1) Project description
- (2) Designation of QA/QC responsibilities
- (3) Statistical tests and data quality objectives
- (4) Sample collection and chain of custody
- (5) Sample analysis
- (6) System controls and preventive maintenance
- (7) Record keeping
- (8) Audits
- (9) Corrective actions
- (10) Quality control reports

members can provide input on appropriate QA/QC procedures based on their experience with Superfund sites.

4.4.3 Field Verification of Sampling Plan and Contingency Plans

For biological sampling, uncontrolled variables can influence the availability of species to be sampled, the efficiency of different types of sampling techniques, and the level of effort required to achieve the sample sizes specified in the SAP. As a consequence, the risk assessor should develop a plan to test the sampling design before the WP and SAP are signed and the site investigation begins. Otherwise, field sampling during the site investigation could fail to meet the DQOs specified in the SAP, and the study could fail to meet its objectives. Step 5 provides a description of the field verification of the sampling design.

To the extent that potential field problems can be anticipated, contingency plans also should be specified in the SAP. An example of a contingency plan is provided in Steps 5 and 6 (Examples 5-2 and 6-1).

4.5 SCIENTIFIC/MANAGEMENT DECISION POINT (SMDP)

The completion of the ecological risk assessment WP and SAP should coincide with an SMDP. Within this SMDP, the ecological risk assessor and the ecological risk manager agree on: (1) selection of measurement endpoints; (2) selection of the site investigation methods; and (3) selection of data reduction and interpretation techniques. The WP or SAP also should specify how inferences will be drawn from the measurement to the assessment endpoints.

4.6 SUMMARY

At the conclusion of Step 4, there will be an agreement on the contents of the WP and SAP. As noted earlier, these plans can be parts of a larger WP and SAP that are developed to meet other remedial investigation needs, or they can be separate documents. When possible, any field sampling efforts for the ecological risk assessment should overlap with other site data collection efforts to reduce sampling costs and to prevent redundant sampling.

The WP and/or the SAP should specify the methods by which the collected data will be analyzed. The plan(s) should include all food-chain-exposure-model parameters, data reduction techniques, data interpretation methods, and statistical analyses that will be used.

STEP 5: FIELD VERIFICATION OF SAMPLING DESIGN

OVERVIEW

Before the WP and SAP are signed, it is important to verify that the field sampling plan they specify is appropriate and implementable at the site. If this has not already been done, it should be done now. During field verification of the sampling design, the testable hypotheses, exposure pathway models, and measurement endpoints are evaluated for their appropriateness and implementability. The assessment endpoint(s), however, should not be under evaluation in this step; the appropriateness of the assessment endpoint should have been resolved in Step 3. If an assessment endpoint is changed at this step, the risk assessor must return to Step 3, because the entire process leading to the actual site investigation in Step 6 assumes the selection of appropriate assessment endpoints.

5.1 PURPOSE

The primary purpose of field verification of the sampling plan is to ensure that the samples specified by the SAP actually can be collected. A species that will be associated with a measurement endpoint and/or exposure point concentration should have been observed at the preliminary site characterization or noted during previous site visits. During this step, previously obtained information should be verified and the feasibility of sampling will need to be checked by a site visit. Preliminary sampling will determine if the targeted species is present and—equally important—collectable in sufficient numbers or total biomass to meet data quality objectives. This preliminary field assessment also allows for final confirmation of the habitats that exist on or near the site. Habitat maps are verified a final time, and interpretations of aerial photographs can be checked.

Final decisions on reference areas also should be made in this step. The reference areas should be chosen to be as similar as possible to the site in all aspects except contamination. Parameters to be evaluated for similarity include, but are not limited to: slope, habitat, species potentially present, soil and sediment characteristics, and for surface waters, flow rates, substrate type, water depth, temperature, turbidity, oxygen levels, water hardness, pH, and other standard water quality parameters. If several on-site habitats or habitat variables are being investigated, then several reference areas could be required. Reference areas should be as free of site-related contaminants above background levels as practical.

5.2 DETERMINING SAMPLING FEASIBILITY

When sampling biota, it is difficult to predict what level of effort will be necessary to obtain an adequate number of individuals of the required size. Some preliminary field measurements often can help determine adequate sampling efforts to attain the sample sizes specified in the SAP for statistical analyses. The WP and SAP should be signed and the site investigation should be implemented immediately after verification of the sampling design to limit effects of uncontrolled field variables. For example, evaluation of current small mammal population density might indicate to the investigator that 400 trap-nights instead of 50 are necessary to collect the required number of small mammals. If there is a time lag between the field sampling verification and the actual site investigation, it could be necessary to reverify the field sampling to determine if conditions have changed.

Sampling methods for abiotic media also should be tested. There is a wide variety of sampling devices and methods, and it is important to use the most appropriate, as the following examples illustrate:

- When sampling a stream's surface water, if the stream is only three inches deep, collecting the water directly into 32-ounce bottles would not be practical.
- Sampling the substrate in a stream might be desirable, but if the substrate is bedrock, it might not be feasible or the intent of the sampling design.

An exposure-response relationship between contamination and biological effects is a key component of establishing causality during the analysis phase of the baseline risk assessment (Step 6). If extent-of-contamination sampling is conducted in phases, abiotic exposure media and biotic samples must be collected simultaneously because the interactions (both temporal and spatial) between the matrix to be remediated and the biota are crucial to the development of a field exposure-response relationship. Failure to collect one sample properly or to coordinate samples temporally can significantly impact the interpretation of the data.

Sampling locations need to be checked to make sure that they are appropriately described and placed within the context of the sampling plan. Directions for a sediment sample "to be taken 5 feet from the north side of stream A," could cause confusion if the stream is only 4 feet wide, or if the sampler doesn't know if the sample should be taken in the stream, or 5 feet away from the edge of the stream. All samples should be checked against the intended use of the data to be obtained.

All pathways for the migration of contaminants off site should be evaluated, such as windblown dust, surface water runoff, and erosion. Along these pathways, a gradient of decreasing contamination with increasing distance from the site might exist. Site-specific ecological evaluations and risk assessments can be more useful to risk managers if gradients of contamination can be located and evaluated.

Contaminant migration pathways might have changed, either due to natural causes (e.g., storms) or site remediation activities (e.g., erosion channels might have been filled or dug up to prevent further migration of contaminants). Channels of small or large streams, brooks, or rivers might have moved; sites might have been flooded. All of the assumptions of the migration and exposure pathways need to be verified prior to the full site investigation. If a contaminant gradient is necessary for the sampling plan, it is important to verify that the gradient exists and that the range of contaminant concentrations is appropriate. A gradient of contamination that causes no impacts at the highest concentration measured has as little value as a gradient that kills everything at the lowest concentration measured; in either case, the gradient would not provide useful exposure-response information. A gradient verification requires chemical sampling, but field screening-level analyses might be effective.

These and other problems associated with the practical implementation of sampling should be resolved prior to finalizing the SAP to the extent practicable. Assessing the feasibility of the sampling plan before the site investigation begins saves costs in the long term because it minimizes the chances of failing to meet DQOs during the site investigation.

Examples 5-1 and 5-2 describe the field verification of the sampling plan for the hypothetical copper and DDT sites illustrated in Appendix A. Note that the scope of the field verification differs for the copper and DDT sites. For the DDT site, a modification to the study design was necessary. For both sites, the issues were resolved and a sign-off was obtained at the SMDP for this step.

Any change in measurement endpoints will require that exposure pathways to the new measurement endpoint be checked. The new measurement endpoint must fit into the established conceptual model. Changes to measurement endpoints might require revision of the conceptual model and agreement to the changes at the SMDP. It is highly desirable that the agreed-upon conceptual model should be modified and approved by the same basic group of individuals who developed it.

5.3 SCIENTIFIC/MANAGEMENT DECISION POINT (SMDP)

The SMDP for the field verification of the sampling design is the signing of the finalized WP and SAP. Any changes to the investigation proposed in Step 4 must be made with agreement from the risk manager and risk assessment team. The risk manager must understand what changes have been made and why, and must ensure that the risk management decisions can be made from the information that the new study design can provide. The risk assessors must be involved to ensure that the assessment endpoints and testable hypotheses are still being addressed.

In the worst cases, changes in the measurement endpoints could be necessary, with corresponding changes to the risk hypotheses and sampling design. Any new measurement endpoints must be evaluated according to their utility for inferring changes in the assessment

EXAMPLE 5-1

Field Verification of Sampling Design—Copper Site

Copper was released from a seep area of a landfill adjacent to a small pond; the release and resulting elevated copper levels in the pond are of concern. The problem formulation and conceptual model stated that the assessment endpoint was the maintenance of a typical pond community for the area, including the benthic invertebrates and fish. Toxicity testing was selected to evaluate the potential toxicity of copper to aquatic organisms. Three toxicity tests were selected: a 10-day solid-phase sediment toxicity test (with the amphipod *Hyaella azteca*), and two water column tests (i.e., the 7-day growth test with the green alga *Selenastrum capricornutum* and the fathead minnow, *Pimephales promelas*, 7-day larval growth test). The study design specified that sediment and water for the toxicity tests would be collected at the leachate seeps known to be at the pond edge, and at three additional equidistant locations transecting the pond (including the point of maximum pond depth). The pond contains water year-round; however, the seep flow depends on rainfall. Therefore, it is only necessary to verify that the leachate seep is active at the time of sampling.

endpoints and their compatibility with the site conceptual model (from Steps 3 and 4). Loss of the relationship between measurement endpoints and the assessment endpoints, the risk questions or testable hypothesis, and the site conceptual model will result in a failure to meet study objectives.

Despite one's best efforts to conduct a sound site assessment, unexpected circumstances might still make it necessary for the sampling plan to be changed in the field. Any changes should be agreed to and documented by the lead risk assessor in consultation with the risk manager.

Once the finalized WP and SAP are approved and signed, Step 6 should begin.

5.4 SUMMARY

In summary, field verification of the sampling plan is very important to ensuring that the DQOs of the site investigation can be met. This step verifies that the selected assessment endpoints, testable hypotheses, exposure pathway model, measurement endpoints, and study design from Steps 3 and 4 are appropriate and implementable at the site. By verifying the field sampling plan prior to conducting the full site investigation, well-considered alterations can be made to the study design and/or implementation if necessary. These changes will ensure that the ecological risk assessment meets the study objectives.

If changing conditions force changes to the sampling plan in the field (e.g., selection of a different reference site), the changes should be agreed to and documented by the lead risk assessor in consultation with the risk manager.

EXAMPLE 5-2 **Field Verification of Sampling Design- DDT Site**

For the stream DDT site, the assessment endpoint was protection of piscivorous birds from adverse reproductive effects. The conceptual model included the exposure pathway of sediment to forage fish to the kingfisher. The measurement endpoint selected was tissue residue levels in creek chub (*Semotilus atromaculatus*), which could be associated with contaminant levels in sediments. Existing information on the stream contamination indicates that a gradient of contamination exists and that five specific sampling locations should be sufficient to characterize the gradient to the point where concentrations are unlikely to have adverse effects. The study design specified that 10 creek chub of the same size and sex be collected at each location. Each chub should be approximately 20 grams, so that minimum sample mass requirements could be met without using composite samples for analysis. In addition, QA/QC protocol requires that 10 more fish be collected at one of the locations.

In this example, a site assessment was necessary to verify that a sufficient number of creek chub of the specified size would be present to meet the sampling requirements. Stream conditions were evaluated to determine what fish sampling technique would work at the targeted locations. A field assessment was conducted, and several fish collection techniques were used to determine which was the most effective for the site. Collected creek chub and other fish were examined to determine the size range available and whether the sex of the individuals could be determined.

The site assessment indicated that the creek chub might not be present in sufficient numbers to provide the necessary biomass for chemical analyses. Based upon those findings, a contingency plan was agreed to, which stated that both the creek chub and the longnosed dace (*Rhinichthys cataractae*) would be collected. If the creek chub were collected at all locations in sufficient numbers, then those samples would be analyzed and the dace would be released. If sufficient creek chub could not be collected but sufficient longnosed dace could, the longnosed dace would be analyzed and the creek chub released. If neither species could be collected at all locations in sufficient numbers, then a mix of the two species would be used; however, for any given sampling location only one species would be used to make the sample. In addition, at one location, which preferably had high DDT levels in the sediment, sufficient numbers (20 grams) of both species would be collected to allow comparison (and calibration) of the accumulation between the two species.

STEP 6: SITE INVESTIGATION AND ANALYSIS PHASE

OVERVIEW

Information collected during the site investigation is used to characterize exposures and ecological effects. The site investigation includes all of the field sampling and surveys that are conducted as part of the ecological risk assessment. The site investigation and analysis of exposure and effects should be straightforward, following the WP and SAP developed in Step 4 and tested in Step 5.

Exposure characterization relies heavily on data from the site investigation and can involve fate-and-transport modeling. Much of the information for characterizing potential ecological effects was gathered from the literature review during problem formulation, but the site investigation might provide evidence of existing ecological impacts and additional exposure-response information.

6.1 INTRODUCTION

The site investigation (Section 6.2) and analysis phase (Section 6.3) of the ecological risk assessment should be straightforward. In Step 4, all issues related to the study design, sample collection, DQOs, and procedures for data reduction and interpretation should have been identified and resolved. However, as described in Step 5, there are circumstances that can arise during a site investigation that could require modifications to the original study design. If any unforeseen events do require a change to the WP or SAP, all changes must be agreed upon at the SMDP (Section 6.4). The results of Step 6 are used to characterize ecological risks in Step 7.

6.2 SITE INVESTIGATION

The WP for the site investigation is based on the site conceptual model and should specify the assessment endpoints, risk questions, and testable hypotheses. The SAP for the site investigation should specify the relationship between measurement and assessment endpoints, the necessary number, volume, and types of samples to be collected, and the sampling techniques to be used. The SAP also should specify the data reduction and interpretation techniques and the DQOs. The feasibility of the sampling design was tested in Step 5. Therefore, the site investigation should be a direct implementation of the previously designed study.

During the site investigation, it is important to adhere to the DQOs and to any requirements for co-located sampling. Failure to collect one sample properly or to coordinate samples temporally can significantly affect interpretation of the data. Changing field conditions (Section 6.2.1) and new information on the nature and extent of contamination (Section 6.2.2) can require a change in the SAP.

6.2.1 Changing Field Conditions

In instances where unexpected conditions arise in the field that make the collection of specified samples impractical or not ideal, the ecological risk assessor should reevaluate the feasibility of the sampling design as described in Step 5. Field efforts should not necessarily be halted, but decisions to change sampling procedures or design must be agreed to by the risk manager and lead risk assessor or project-delegated equivalents.

Field modifications to study designs are not uncommon during field investigations. When the WP and SAP provide a precise conceptual model and study design with specified data analyses, informed modifications to the SAP can be made to comply with the objectives of the study. As indicated in Step 4, contingency plans can be included in the original SAP in anticipation of situations that might arise during the site investigation (see Example 6-1). Any modifications, and the reasons for the modifications, must be documented in the baseline risk assessment.

EXAMPLE 6-1 Fish Sampling Contingency Plan—DDT Site

At the DDT site where creek chub are to be collected for DDT tissue residue analyses, a contingency plan for the site investigation was developed. An alternate species, the longnosed dace, was specified with the expectation that, at one or all locations, the creek chub might be absent at the time of the site investigation. Such contingency plans are prudent even when the verification of the field sampling design described in Step 5 indicates that the samples are obtainable.

6.2.2 Unexpected Nature or Extent of Contamination

It is not uncommon for an initial sampling phase of the RI to reveal that contamination at levels of concern extend beyond areas initially established for characterizing contamination and ecological effects at the site or that contaminant gradients are much steeper than anticipated. If this contingency changes the opportunity for evaluating biological effects along a contamination gradient, the ecological risk assessors and risk manager need to determine whether additional sampling (e.g., further downstream from the site) is needed.

Thus, it is important for the ecological risk assessors to track information on the nature and extent of contamination as RI sampling is conducted.

On occasion, new contaminants are identified during an RI. In this case, the risk assessors and site manager will need to return to Step 1 to screen the new contaminants for ecological risk.

Immediate analysis of the data for each type of sampling and communication between the risk assessors and risk managers can help ensure that the site investigation is adequate to achieve the study goals and objectives when field modifications are necessary. If a change to the WP or SAP is needed, the lead risk assessor and risk manager must agree on all changes (the SMDP in Section 6.4).

6.3 ANALYSIS OF ECOLOGICAL EXPOSURES AND EFFECTS

The analysis phase of the ecological risk assessment consists of the technical evaluation of data on existing and potential exposures (Section 6.3.1) and ecological effects (Section 6.3.2) at the site. The analysis is based on the information collected during Steps 1 through 5 and often includes additional assumptions or models to interpret the data in the context of the site conceptual model. As illustrated in Exhibit 6-1, analysis of exposure and effects is performed interactively, with the analysis of one informing the analysis of the other. This step follows the data interpretation and analysis methods specified in the WP and SAP, and therefore should be a straightforward process.

In the analysis phase, the site-specific data obtained during the site investigation replace many of the assumptions that were made for the screening-level analysis in Steps 1 and 2. For the exposure and ecological effects characterizations, the uncertainties associated with the field measurements and with assumptions where site-specific data are not available must be documented.

6.3.1 Characterizing Exposures

Exposure can be expressed as the co-occurrence or contact of the stressor with the ecological components, both in time and space (U.S. EPA, 1992a). Thus, both the stressor and the ecosystem must be characterized on similar temporal and spatial scales. The result of the exposure analysis is an exposure profile that quantifies the magnitude and spatial and temporal patterns of exposure as they relate to the assessment endpoints and risk questions developed during problem formulation. The exposure profile and a description of associated uncertainties and assumptions serve as input to the risk characterization in Step 7.

Stressor characterization involves determining the stressor's distribution and pattern of change. The analytic approach for characterizing ecological exposures should have been established in the WP and SAP on the basis of the site conceptual model. For chemical

**EXHIBIT 6-1
Analysis Phase (U.S. EPA, 1992a)**

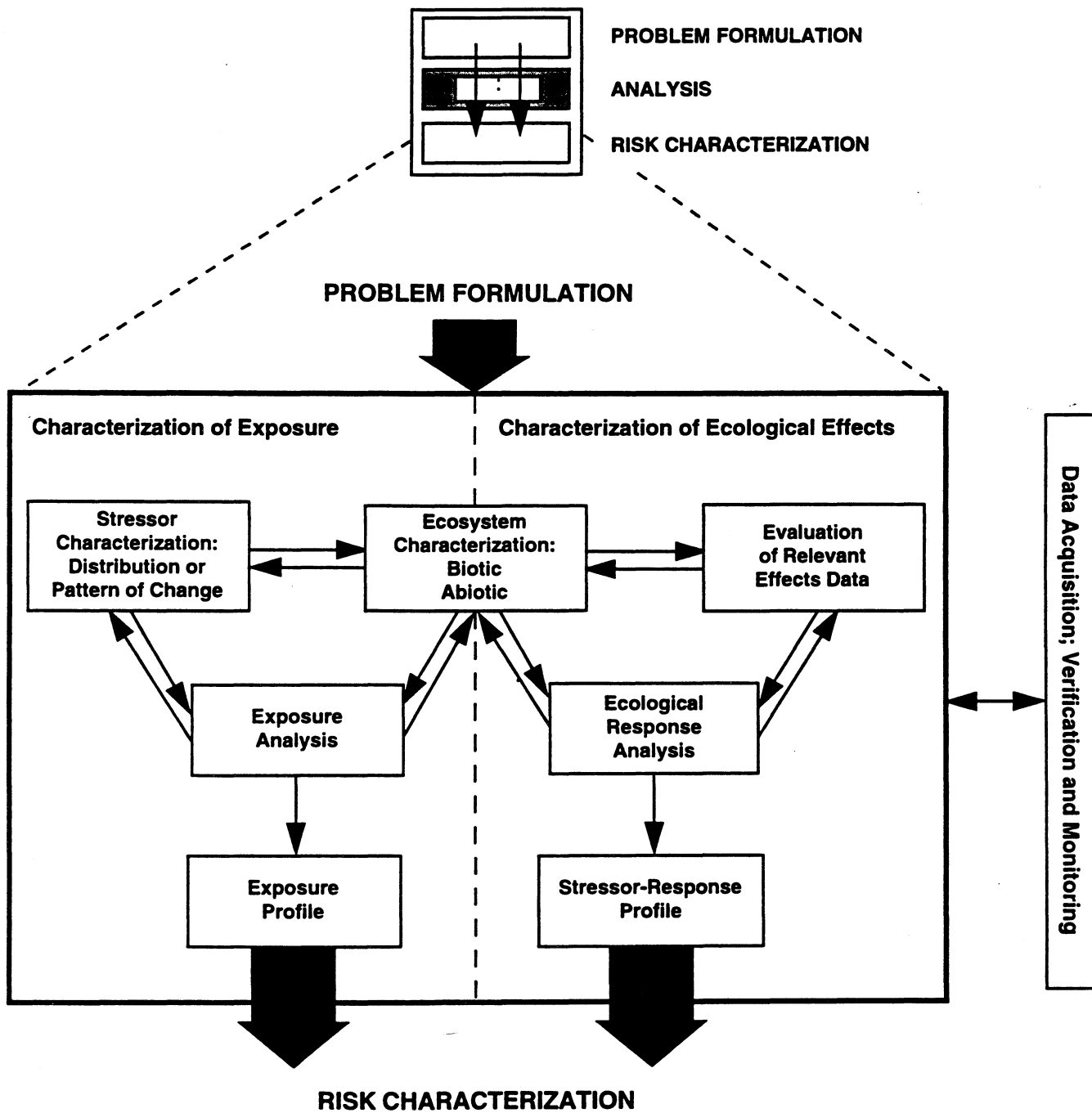

stressors at Superfund sites, usually a combination of fate-and-transport modeling and sampling data from the site are used to predict the current and likely future nature and extent of contamination at a site.

When characterizing exposures, the ecological context of the site established during problem formulation is analyzed further, both to understand potential effects of the ecosystem on fate and transport of chemicals in the environment and to evaluate site-specific characteristics of species or communities of concern. Any site-specific information that can be used to replace assumptions based on information from the literature or from other sites is incorporated into the description of the ecological components of the site. Remaining assumptions and uncertainties in the exposure model (Highlight 6-1) should be documented.

HIGHLIGHT 6-1 **Uncertainty in Exposure Models**

The accuracy of an exposure model depends on the accuracy of the input parameter values and the validity of the model's structure (i.e., the degree to which it represents the actual relationships among parameters at the site). Field measurements can be used to calibrate model outputs or intermediate calculations. Such field measurements should be specified in the WP and SAP. For example, studies of tissue residue levels often are used to calibrate exposure and food-chain models.

6.3.2 Characterizing Ecological Effects

At this point, all evidence for existing and potential adverse effects on the assessment endpoints is analyzed. The information from the literature review on ecological effects is integrated with any evidence of existing impacts based on the site investigation (e.g., toxicity testing). The methods for analyzing site-specific data should have been specified in the WP and SAP, and thus should be straightforward. Both exposure-response information and evidence that site contaminants are causing or can cause adverse effects are evaluated.

Exposure-response analysis. The exposure-response analysis for a Superfund site describes the relationship between the magnitude, frequency, or duration of a contaminant stressor in an experimental or observational setting and the magnitude of response. In this phase of the analysis, measurement endpoints are related to the assessment endpoints using the logical structure provided by the conceptual model. Any extrapolations that are required to relate measurement to assessment endpoints (e.g., between species, between response levels, from laboratory to field) are explained. Finally, an exposure-response relationship is described to the extent possible (e.g., by a regression equation), including the confidence limits (quantitative or qualitative) associated with the relationship.

Under some circumstances, site-specific exposure-response information can be obtained by evaluating existing ecological impacts along a contamination gradient at the site. Statistical techniques to identify or describe the relationship between exposure and response from the field data should have been specified in the WP and SAP. The potential for

confounding stressors that might correlate with the contamination gradient should be documented (e.g., decreasing water temperature downstream of a site; reduced soil erosion further from a site).

An exposure-response analysis is of particular importance to risk managers who must balance human health and ecological concerns against the feasibility and effectiveness of remedial options. An exposure-response function can help a risk manager to specify the trade-off between the degree of cleanup and likely benefits of the cleanup and to balance ecological and financial costs and benefits of different remedial options, as discussed in Step 8.

When exposure-response data are not available or cannot be developed, a threshold for adverse effects can be developed instead, as in Step 2. For the baseline risk assessment, however, site-specific information should be used instead of conservative assumptions whenever possible.

Evidence of causality. At Superfund sites, evidence of causality is key to the risk assessment. Thus, it is important to evaluate the strength of the causal association between site-related contaminants and effects on the measurement and assessment endpoints. Demonstrating a correlation between a contaminant gradient and ecological impacts at a site is a key component of establishing causality, but other evidence can be used in the absence of such a demonstration. Moreover, an exposure-response correlation at a site is not sufficient to demonstrate causality, but requires one or more types of supporting evidence and analysis of potential confounding factors. Hill's (1965) criteria for evaluating causal associations are outlined in the *Framework* (U.S. EPA, 1992a).

6.4 SCIENTIFIC/MANAGEMENT DECISION POINT (SMDP)

An SMDP during the site investigation and analysis phase is needed only if alterations to the WP or SAP become necessary. In the worst case, changes in measurement endpoints could be required, with corresponding changes to the testable hypotheses and sampling design. Any new measurement endpoints must be evaluated according to their utility for inferring changes in the assessment endpoints and their compatibility with the site conceptual model; otherwise, the study could fail to meet its objectives.

Proposed changes to the SAP must be made in consultation with the risk manager and the risk assessors. The risk manager must understand what changes have been made and why, and must ensure that the risk management decisions can be made from the information that the new study design can provide. The risk assessors must be involved to ensure that the assessment endpoints and study questions or testable hypotheses are still being addressed.

6.5 SUMMARY

The site investigation step of the ecological risk assessment should be a straightforward implementation of the study designed in Step 4 and verified in Step 5. In instances where unexpected conditions arise in the field that indicate a need to change the study design, the ecological risk assessors should reevaluate the feasibility or adequacy of the sampling design. Any proposed changes to the WP or SAP must be agreed upon by both the risk assessment team and the risk manager and must be documented in the baseline risk assessment.

The analysis phase of the ecological risk assessment consists of the technical evaluation of data on existing and potential exposures and ecological effects and is based on the information collected during Steps 1 through 5 and the site investigation in Step 6. Analyses of exposure and effects are performed interactively, and follow the data interpretation and analysis methods specified in the WP and SAP. Site-specific data obtained during Step 6 replace many of the assumptions that were made for the screening-level analysis in Steps 1 and 2. Evidence of an exposure-response relationship between contamination and ecological responses at a site helps to establish causality. The results of Step 6 are used to characterize ecological risks in Step 7.

STEP 7: RISK CHARACTERIZATION

OVERVIEW

In risk characterization, data on exposure and effects are integrated into a statement about risk to the assessment endpoints established during problem formulation. A weight-of-evidence approach is used to interpret the implications of different studies or tests for the assessment endpoints. In a well-designed study, risk characterization should be straightforward, because the procedures were established in the WP and SAP. The risk characterization section of the baseline ecological risk assessment should include a qualitative and quantitative presentation of the risk results and associated uncertainties.

7.1 INTRODUCTION

Risk characterization is the final phase of the risk assessment process and includes two major components: risk estimation and risk description (U.S. EPA, 1992a; Exhibit 7-1). Risk estimation (Section 7.2) consists of integrating the exposure profiles with the exposure-effects information and summarizing the associated uncertainties. The risk description (Section 7.3) provides information important for interpreting the risk results and, in the Superfund Program, identifies a threshold for adverse effects on the assessment endpoints (Section 7.4).

It is U.S. EPA policy that risk characterization should be consistent with the values of "transparency, clarity, consistency, and reasonableness" (U.S. EPA, 1995f). "Well-balanced risk characterizations present risk conclusions and information regarding the strengths and limitations of the assessment for other risk assessors, EPA decision-makers, and the public" (U.S. EPA, 1995f). Thus, when preparing the risk characterization, the risk assessment team should make sure that the documentation of risks is easy to follow and understand, with all assumptions, defaults, uncertainties, professional judgments, and any other inputs to the risk estimate clearly identified and easy to find.

7.2 RISK ESTIMATION

Documentation of the risk estimates should describe how inferences are made from the measurement endpoints to the assessment endpoints established in problem formulation. As stated earlier, it is not the purpose of this document to provide a detailed guidance on the selection and utilization of risk models. The risk assessment team should have developed and the risk manager should have agreed upon the conceptual model used to characterize risk, its

**EXHIBIT 7-1
Risk Characterization (U.S. EPA, 1992a)**

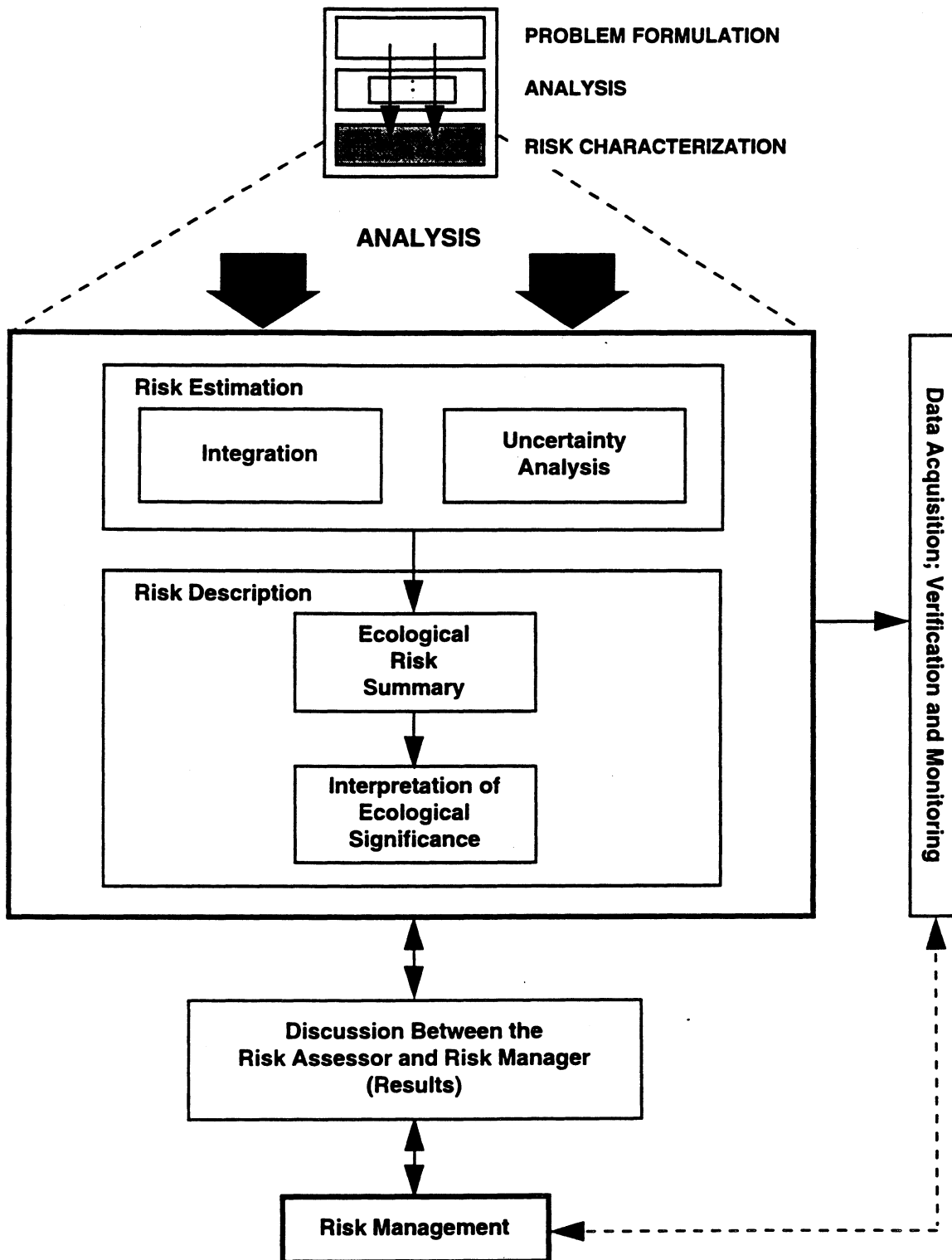

assumptions, uncertainties, and interpretation in Steps 3 through 5. This agreement is specified in the site WP and SAP and is the purpose of the SMDPs in Steps 3 through 5.

Unless the site investigation during Step 6 discovers unexpected information, the risk assessment should move smoothly through the risk characterization phase, because the data interpretation procedures were specified in the WP and SAP. While it might be informative to investigate a data set for trends, outliers, or other statistical indicators, these investigations should be secondary to the data interpretations specified in the SAP. Analysis of the data beyond the purposes for which it was collected might be informative, but could lead to biased, conflicting, or superfluous conclusions. Those outcomes can divert or confound the risk characterization process.

For ecological risk assessments that entail more than one type of study (or line of evidence), a strength-of-evidence approach is used to integrate different types of data to support a conclusion. The data might include toxicity test results, assessments of existing impacts at a site, or risk calculations comparing exposures estimated for the site with toxicity values from the literature. Balancing and interpreting the different types of data can be a major task and require professional judgment. As indicated above, the strength of evidence provided by different types of tests and the precedence that one type of study might have over another should already have been established during Step 4. Taking this approach will ensure that data interpretation is objective and not biased to support a preconceived answer. Additional strength-of-evidence considerations at this stage include the degree to which DQOs were met and whether confounding factors became evident during the site investigation and analysis phase.

For some biological tests (e.g., toxicity tests, benthic macroinvertebrate studies), all or some of the data interpretation process is outlined in existing documents, such as in toxicity testing manuals. However, in most cases, the SAP must provide the details on how the data are to be interpreted for a site. The data interpretation methods also should be presented in the risk characterization documentation. For example, if the triad approach was used to evaluate contaminated sediments, the risk estimation section should describe how the three types of studies (i.e., toxicity test, benthic invertebrate survey, and sediment chemistry) are integrated to draw conclusions about risk.

Where exposure-response functions are not available or developed, the quotient method of comparing an estimated exposure concentration to a threshold for response can be used, as in Step 2. Whenever possible, however, presentation of full exposure-response functions provides the risk manager with more information on which to base site decisions. This guidance has recommended the use of on-site contamination gradients to demonstrate on-site exposure-response functions. Where such data have been collected, they should be presented along with the risk estimates. Hazard quotients, hazard indices (for contaminants with the same mechanism of toxicity), the results of *in situ* toxicity testing, or community survey data can be mapped along with analytic chemistry data to provide a clear picture of the relationship between areas of contamination and effects.

In addition to developing point estimates of exposure concentrations, as for the hazard quotient approach, it might be possible to develop a distribution of exposure levels based on the potential variability in various exposure parameters (see Section 7.3.2). Probabilities of exceeding a threshold for adverse effects might then be estimated. Again, the risk assessment team and risk manager should have already agreed to what analyses will be used to characterize risks.

7.3 RISK DESCRIPTION

A key to risk description for Superfund sites is documentation of environmental contamination levels that bound the threshold for adverse effects on the assessment endpoints (Section 7.3.1). The risk description can also provide information to help the risk manager judge the likelihood and ecological significance of the estimated risks (Sections 7.3.2 and 7.3.3, respectively).

7.3.1 Threshold for Effects on Assessment Endpoints

Key outputs of the risk characterization step are contaminant concentrations in each environmental medium that bound the threshold for estimated adverse ecological effects given the uncertainty inherent in the data and models used. The lower bound of the threshold would be based on consistent conservative assumptions and NOAEL toxicity values. The upper bound would be based on observed impacts or predictions that ecological impacts could occur. This upper bound would be developed using consistent assumptions, site-specific data, LOAEL toxicity values, or an impact evaluation.

The approach to estimating environmental contaminant concentrations that represent thresholds for adverse ecological effects should have been specified in the study design (Step 4). When higher-trophic-level organisms are associated with assessment endpoints, the study design should have described how monitoring data and contaminant-transfer models would be used to back-calculate an environmental concentration representing a threshold for effect. If the site investigation demonstrated a gradient of ecological effects along a contamination gradient, the risk assessment team can identify and document the levels of contamination below which no further improvements in the assessment endpoints are discernable or expected. If departures from the original analysis plan are necessary based on information obtained during the site investigation or data analysis phase, the reasons for change should be documented.

When assessment endpoints include populations of animals that can travel moderate distances, different ways of presenting a threshold for adverse effects are possible. Various combinations of level of contamination and areal extent of contamination relative to the foraging range of the animals can result in similar contaminant intake levels by the animals. In that case, a point of departure for identifying a threshold for effect would be to identify that level of contamination, which if uniformly distributed both at the site and beyond, would

not pose a threat. The assumption of uniform contamination has been used to back-calculate water-quality criteria to protect piscivorous wildlife in the Great Lakes (U.S. EPA, 1995a). Again, use of this approach should have been specified in the study design.

7.3.2 Likelihood of Risk

In addition to identifying one or more thresholds for effects, the risk assessment team might develop estimates of the probability that exposure levels would exceed the ecotoxicity thresholds given the distribution of values likely for various exposure parameters (e.g., home range size, population density). A distributional analysis might be used to estimate the range of likely exposure levels associated with a given exposure model based on ranges for the input variables.

7.3.3 Additional Risk Information

In addition to developing numerical estimates of existing impacts, risks, and thresholds for effect, the risk assessor should put the estimates in context with a description of their extent, magnitude, and potential ecological significance. Additional ecological risk descriptors are listed below:

- The location and areal extent of existing contamination above a threshold for adverse effects;
- The degree to which the threshold for contamination is exceeded or is likely to be exceeded in the future, particularly if exposure-response functions are available; and
- The expected half-life (qualitative or quantitative) of contaminants in the environment (e.g., sediments, food chain) and the potential for natural recovery once the sources of contamination are removed.

To interpret the information in light of remedial options, the risk manager might need to solicit input from specific experts.

At this stage, it is important for the risk assessors to consider carefully several principles of risk communication, as described in U.S. EPA's (1996a) *Proposed Guidelines for Ecological Risk Assessment*.

7.4 UNCERTAINTY ANALYSIS

There are several sources of uncertainties associated with Superfund ecological risk estimates. One is the initial selection of substances of concern based on the sampling data and available toxicity information. Other sources of uncertainty include estimates of toxicity

to ecological receptors at the site based on limited data from the laboratory (usually on other species), from other ecosystems, or from the site over a limited period of time. Additional uncertainties result from the exposure assessment, as a consequence of the uncertainty in chemical monitoring data and models used to estimate exposure concentrations or doses. Finally, further uncertainties are included in risk estimates when simultaneous exposures to multiple substances occur.

Uncertainty should be distinguished from variability, which arises from true heterogeneity or variation in characteristics of the environment and receptors. Uncertainty, on the other hand, represents lack of knowledge about certain factors which can sometimes be reduced by additional study.

This section briefly notes several categories of uncertainty (Section 7.4.1) and techniques for tracking uncertainty through a risk assessment (Section 7.4.2). Additional guidance on discussing uncertainty and variability in risk characterization is provided in U.S. EPA's (1992f) *Guidance on Risk Characterization for Risk Managers and Risk Assessors*.

7.4.1 Categories of Uncertainty

There are three basic categories of uncertainties that apply to Superfund site risk assessments: (1) conceptual model uncertainties; (2) natural variation and parameter error; and (3) model error. Each of these is described below.

There will be uncertainties associated with the conceptual model used as the basis to investigate the site. The initial characterization of the ecological problems at a Superfund site, likely exposure pathways, chemicals of concern, and exposed ecological components, requires professional judgments and assumptions. To the extent possible, the risk assessment team should describe what judgments and assumptions were included in the conceptual model that formed the basis of the WP and SAP.

Parameter values (e.g., water concentrations, tissue residue levels, food ingestion rates) usually can be characterized as a distribution of values, described by central tendencies, ranges, and percentiles, among other descriptors. When evaluating uncertainty in parameter values, it is important to distinguish uncertainty from variability. Ecosystems include highly variable abiotic (e.g., weather, soils) and biotic (e.g., population density) components. If all instances of a parameter (e.g., all members of a population) could be sampled, the "true" parameter value distribution could be described. In practical terms, however, only a fraction of the instances (e.g., a few of the members of the population) can be sampled, leaving uncertainty concerning the true parameter value distribution. The risk assessor should provide either quantitative or qualitative descriptions of uncertainties in parameter value distributions.

Finally, there is uncertainty associated with how well a model (e.g., fate and transport model) approximates true relationships between site-specific environmental conditions. Models available at present tend to be fairly simple and at best, only partially validated with

field tests. As a consequence, it is important to identify key model assumptions and their potential impacts on the risk estimates.

7.4.2 Tracking Uncertainties

In general, there are two approaches to tracking uncertainties through a risk assessment: (1) using various point estimates of exposure and response to develop one or more point estimates of risk; and (2) conducting a distributional analysis to predict a distribution of risks based on a distribution of exposure levels and exposure-response information. Whether one or the other or both approaches are taken should have been agreed to during Step 4, and the specific type of analyses to be conducted should have been specified in the SAP.

7.5 SUMMARY

Risk characterization integrates the results of the exposure profile and exposure-response analyses, and is the final phase of the risk assessment process. It consists of risk estimation and risk description, which together provide information to help judge the ecological significance of risk estimates in the absence of remedial activities. The risk description also identifies a threshold for effects on the assessment endpoint as a range between contamination levels identified as posing no ecological risk and the lowest contamination levels identified as likely to produce adverse ecological effects. To ensure that the risk characterization is transparent, clear, and reasonable, information regarding the strengths and limitations of the assessment must be identified and described.

STEP 8: RISK MANAGEMENT

OVERVIEW

Risk management at a Superfund site is ultimately the responsibility of the site risk manager, who must balance risk reductions associated with cleanup of contaminants with potential impacts of the remedial actions themselves. The risk manager considers inputs from the risk assessors, BTAGs, stakeholders, and other involved parties. In Step 7, the risk assessment team identified a threshold for effects on the assessment endpoint as a range between contamination levels identified as posing no ecological risk and the lowest contamination levels identified as likely to produce adverse ecological effects. In Step 8, the risk manager evaluates several factors in deciding whether or not to clean up to within that range.

8.1 INTRODUCTION

Risk management is a distinctly different process from risk assessment (NRC, 1983, 1994; U.S. EPA, 1984a, 1995f). The risk assessment establishes whether a risk is present and defines a range or magnitude of the risk. In risk management, the results of the risk assessment are integrated with other considerations to make and justify risk management decisions. Additional risk management considerations can include the implications of existing background levels of contamination, available technologies, tradeoffs between human and ecological concerns, costs of alternative actions, and remedy selection. For further information on management of ecological risks Agency-wide, see U.S. EPA 1994h. Some Superfund-specific considerations are described below.

8.2 ECOLOGICAL RISK MANAGEMENT IN SUPERFUND

According to section 300.40 of the NCP, the purpose of the remedy selection process is to eliminate, reduce, or control risks to human health and the environment. The NCP indicates further that the results of the baseline risk assessment will help to establish acceptable exposure levels for use in developing remedial alternatives during the FS. Based on the criteria for selecting the preferred remedy and, using information from the human health and ecological risk assessments and the evaluation of remedial options in the FS, the risk manager then selects a preferred remedy.

The risk manager must consider several types of information in addition to the baseline ecological risk assessment when evaluating remedial options (Section 8.2.1). Of

particular concern for ecological risk management at Superfund sites is the potential for remedial actions themselves to cause adverse ecological impacts (Section 8.2.2). There also exists the opportunity to monitor ecological components at the site to gauge the effectiveness (or impacts) of the selected remedy (Section 8.2.3).

8.2.1 Other Risk Management Considerations

The baseline ecological risk assessment is not the only set of information that the risk manager must consider when evaluating remedial options during the FS phase of the Superfund process. The NCP (40 CFR 300.430(f)(1)(i)) specifies that each remedial alternative should be evaluated according to nine criteria. Two are considered threshold criteria, and take precedence over the others:

- (1) Overall protection of human health and the environment; and
- (2) Compliance with applicable or relevant and appropriate requirements (ARARs) (unless waiver applicable).

As described in Section 8.2.2 below, a particularly important consideration for the first criterion are the ecological impacts of the remedial options.

Five of the nine criteria are considered primary balancing criteria to be considered after the threshold criteria:

- (3) Long-term effectiveness and permanence;
- (4) Reduction of toxicity, mobility, or volume of hazardous wastes through the use of treatment;
- (5) Short-term effectiveness;
- (6) Implementability; and
- (7) Cost.

Finally, two additional criteria are referred to as modifying criteria that must be considered:

- (8) State acceptance, and
- (9) Community acceptance.

Effective risk communication is particularly important to help ensure that a remedial option that best satisfies the other criteria can be implemented at a site. U.S. EPA's (1996a)

Proposed Guidelines for Ecological Risk Assessment provides an overview of this topic and identifies some of the relevant literature.

Additional factors that the site risk manager takes into consideration include existing background levels (see U.S. EPA, 1994g); current and likely future land uses (see U.S. EPA, 1995c); current and likely future resource uses in the area; and local, regional, and national ecological significance of the site. Consideration of the ecological impacts of remedial options and residual risks associated with leaving contaminants in place are very important considerations, as described in the next section.

8.2.2 Ecological Impacts of Remedial Options

Management of ecological risks must take into account the potential for impacts to the ecological assessment endpoints from implementation of various remedial options. The risk manager must balance: (1) residual risks posed by site contaminants before and after implementation of the selected remedy with (2) the potential impacts of the selected remedy on the environment independent of contaminant effects. The selection of a remedial alternative could require tradeoffs between long-term and short-term risk.

The ecological risks posed by the "no action" alternative are the risks estimated by the baseline ecological risk assessment. In addition, each remedial option is likely to have its own ecological impact. This impact could be anything from a short-term loss to complete and permanent loss of the present habitat and ecological communities. In instances where substantial ecological impacts will result from the remedy (e.g., dredging a wetland), the risk manager will need to consider ways to mitigate the impacts of the remedy and compare the mitigated impacts to the threats posed by the site contamination.

During the FS, the boundaries of potential risk under the no-action alternative (i.e., baseline conditions) can be compared with the evaluation of potential impacts of the remedial options to help justify the preferred remedy. As indicated above, the preferred remedy should minimize the risk of long-term impacts that could result from the remedy and any residual contamination. When the selected remedial option leaves some site contaminants presumed to pose an ecological risk in place, the justification for the selected remedy must be clearly documented.

In short, consideration of the environmental effects of the remedy itself might result in a decision to allow contaminants to remain on site at levels higher than the threshold for effects on the assessment endpoint. Thus, selection of the most appropriate ecologically based remedy can result in residual contamination that presents some risk.

8.2.3 Monitoring

Ecological risk assessment is a relatively new field with limited data available to validate its predictions. At sites where remedial actions are taken to reduce ecological

impacts and risks, the results of the remediation efforts should be compared with the predictions made during the ecological risk assessment.

While it often is difficult to demonstrate the effectiveness of remedial actions in reducing human health risks, it often is possible to demonstrate the effectiveness of remediations to reduce ecological risks, particularly if a several-year monitoring program is established. The site conceptual model provides the conceptual basis for monitoring options, and the site investigation should have indicated which options might be most practical for the site. Monitoring also is important to assess the effectiveness of a no-action alternative. For example, monitoring sediment contamination and benthic communities at intervals following removal of a contaminant source allows one to test predictions of the potential for the ecosystem to recover naturally over time.

8.3 SCIENTIFIC/MANAGEMENT DECISION POINT (SMDP)

The risk management decision is finalized in the Record of Decision (ROD). The decision should minimize the risk of long-term impacts that could result from the remedy and any residual contamination. When the selected remedy leaves residual contamination at levels higher than the upper-bound estimate of the threshold for adverse effects on the assessment endpoint, the risk manager should justify the decision (e.g., describe how a more complete physical remedy could jeopardize an ecological community more than the residual contamination).

8.4 SUMMARY

Risk-management decisions are the responsibility of the risk manager (the site manager), not the risk assessor. The risk manager should have been involved in planning the risk assessment; knowing the options available for reducing risks, the risk manager can help to frame questions during the problem-formulation phase of the risk assessment.

The risk manager must understand the risk assessment, including its uncertainties, assumptions, and level of resolution. With an understanding of potential adverse effects posed by residual levels of site contaminants and posed by the remedial actions themselves, the risk manager can balance the ecological costs and benefits of the available remedial options. Understanding the uncertainties associated with the risk assessment also is critical to evaluating the overall protectiveness of any remedy.

BIBLIOGRAPHY

This combined reference list and bibliography is intended to provide a broad, but not all inclusive, list of other materials that may provide useful information for ecological risk assessments at Superfund sites. These documents include other Superfund Program guidance documents, standard guides for toxicity testing, other EPA program office references with potential applications at Superfund sites, and other ecological risk assessment reference materials. References cited in the text are marked with an asterisk (*).

- American Public Health Association (APHA). 1989. *Standard Methods for Examination of Water and Wastewater. 17th edition.* Washington, DC: APHA.
- American Society for Testing and Materials (ASTM). 1994a. *Annual Book of ASTM Standards.* Philadelphia, PA: ASTM.
- American Society for Testing and Materials (ASTM). 1994b. Standard guide for conducting sediment toxicity tests with freshwater invertebrates: ASTM Standard E 1383-94.
- American Society for Testing and Materials (ASTM). 1993a. Standard terminology relating to biological effects and environmental fate: ASTM Standard E 943-93.
- American Society for Testing and Materials (ASTM). 1993b. Standard guide for designing biological tests with sediments: ASTM Standard E 1525-93.
- American Society for Testing and Materials (ASTM). 1993. *ASTM Standards of Aquatic Toxicology and Hazard Evaluation.* Philadelphia, PA: ASTM.
- American Society for Testing and Materials (ASTM). 1992. Standard guide for conducting sediment toxicity tests with freshwater invertebrates: ASTM Standard E 1383-92.
- American Society for Testing and Materials (ASTM). 1992. Standard guide for conducting 10-day static sediment toxicity tests with marine and estuarine amphipods: ASTM Standard E 1367-92.
- American Society for Testing and Materials (ASTM). 1990. Standard guide for collection, storage, characterization, and manipulation of sediments for toxicological testing: ASTM Standard E 1391-90.
- American Society for Testing and Materials (ASTM). 1988. Standard guide for conducting early life-stage toxicity tests with fishes: ASTM Standard E 1241-88.

- American Society for Testing and Materials (ASTM). 1984. Standard Practice for conducting bioconcentration tests with fishes and saltwater bivalve mollusks: ASTM Standard E 1022-84.
- American Society for Testing and Materials (ASTM). 1980. Practice for conducting acute toxicity tests with fishes, macroinvertebrates, and amphibians: ASTM Standard E 729-80.
- American Society for Testing and Materials (ASTM). 1980. Practice for conducting static acute toxicity tests with larvae of four species of bivalve mollusks: ASTM Standard E 724-80.
- *Anderson and Hickey. 1972. Eggshell changes in certain North American birds. *Proc. Int. Ornithol. Congr.* 15: 514-540.
- Ankley, G.T.; Thomas, N.A.; Di Toro, D.M.; et al. 1994. Assessing potential bioavailability of metals in sediments: a proposed approach. *Environ. Manage.* 18: 331-337.
- *Aulerich, R.J.; Ringer, R.K. 1977. Current status of PCB toxicity to mink and effect on their young. *Arch. Environ. Contam. Toxicol.* 6: 279-292.
- *Aulerich, R.J.; Bursian, S.J.; Breslin, W.J.; et al. 1985. Toxicological manifestations of 2,4,5-,2',4',5'-, 2,3,6,2',3',6'-, and 3,4,5,3',4',5'-hexachlorobiphenyl and Aroclor 1254 in mink. *J. Toxicol. Environ. Health* 15: 63-79.
- Barnhouse, L.W.; Suter, G.W.; Bartell, S.M.; et al. 1986. *User's Manual for Ecological Risk Assessment*. Oak Ridge, TN: Oak Ridge National Laboratory, Environmental Sciences Division Publication No. 2679.
- Bartell, S.M.; Gardner, R.H.; O'Neill, R.V. 1992. *Ecological Risk Estimation*. New York, NY: Lewis Publishers.
- Baudo, R.; Giesy, J.P.; Muntau, H. 1990. *Sediments: Chemistry and Toxicity of In-place Pollutants*. Ann Arbor, MI: Lewis Publishers.
- Burton, G.A., Jr. (ed.). 1992. *Sediment Toxicity Assessment*. Ann Arbor, MI: Lewis Publishers.
- Cairns, J. Jr.; Niederlehner, B.R. 1995. *Ecological Toxicity Testing: Scale, Complexity, and Relevance*. Boca Raton, FL: CRC Press, Inc., Lewis Publishers.
- Calabrese, E.J.; Baldwin, L.A. 1993. *Performing Ecological Risk Assessments*. New York, NY: Lewis Publishers.

- Carter, M.R. (ed.). 1993. *Soil Sampling and Methods of Analysis*. Boca Raton, FL: CRC Press, Inc., Lewis Publishers.
- *Chapman, P.M.; Power, E.A.; Burton, G.A., Jr. 1992. Integrative assessments in aquatic ecosystems. In: Burton, G.A., Jr., (ed.) *Sediment Toxicity Assessment*. Boca Raton, FL: Lewis Publishers.
- Calow, P. (ed.). 1993. *Handbook of Ecotoxicology, Volume 1*. Boston, MA: Blackwell Publishers.
- Cochran, W.G. 1977. *Sampling Techniques. Third edition*. New York, NY: John Wiley and Sons, Inc.
- Cochran, W.G.; Cox, G.M. 1957. *Experimental Design*. New York, NY: Wiley.
- Cockerham, L.G.; Shane, B.S. (eds.). 1994. *Basic Environmental Toxicology*. Boca Raton, FL: CRC Press, Inc., Lewis Publishers.
- *Cooke, A.S. 1971. Selective predation by newts on frog tadpoles treated with DDT. *Nature* 229: 275-276.
- Cowardin, L.M.; Carter, V.; Golet, F.C.; LaRoe, E.T. 1979. *Classification of Wetlands and Deepwater Habitats of the United States*. Washington, DC: U.S. Fish and Wildlife Service; FWS/OBS-79/31.
- Crawley, M.J. 1993. *GLIM for Ecologists*. Oxford, UK: Blackwell Scientific Publications.
- Curtis, H. 1983. *Biology. Fourth Edition*. New York, NY: Worth.
- Daniel, W.W. 1990. *Applied Nonparametric Statistics*. Boston, MA: PWS-KENT Publishing Company.
- Davis, W.S.; Simon, T.P. 1995. *Biological Assessment and Criteria: Tools for Water Resource Planning and Decision Making*. Boca Raton, FL: CRC Press, Inc., Lewis Publishers.
- Diggle, P.J. 1990. *Time Series: A Biosatistical Introduction*. Oxford Statistical Science Series No. 5. Oxford, UK: Clarendon Press.
- *Dilworth, T.G., Keith, J.A.; Pearce, P.A.; Reynolds, L.M. 1972. DDE and eggshell thickness in New Brunswick woodcock. *J. Wildl. Manage.* 36: 1186-1193.
- *Dourson, M.L.; Stara, J.F. 1983. Regulatory history and experimental support of uncertainty (safety) factors. *Reg. Toxicol. Pharmacol.* 3: 224-238.

- Finney, D.J. 1964. *Statistical Method in Biological Assay*. London, UK: Charles Griffin and Company.
- Finney, D.J. 1970. *Probit Analysis: A Statistical Treatment of the Sigmoid Response Curve*. Cambridge, UK: Cambridge University Press.
- *Foley, R.E.; Jackling, S.J.; Sloan, R.J. et al. 1988. Organochlorine and mercury residues in wild mink and otter: comparison with fish. *Environ. Toxicol. Chem.* 7: 363-374.
- *Fox, G.A.; Collins, B.; Hayaskawa, E.; et al. 1991. Reproductive outcomes in colonial fish-eating birds: a biomarker for developmental toxicants in Great Lakes food chains. II. Spatial variation in the occurrence and prevalence of bill defects in young double-crested cormorants in the Great Lakes. *J. Great Lakes Res.* 17:158-167.
- Freedman, B. 1989. *Environmental Ecology. The Impacts of Pollution and Other Stresses on Ecosystem Structure and Function*. New York, NY: Academic Press.
- *Geller, M.D. 1979. Dynamics of three populations of *Microtus pennsylvanicus* in the Northwestern United States. PhD Thesis. Binghamton, NY: State University of New York.
- Gilbert, R.O. 1987. *Statistical Methods for Environmental Pollution Monitoring*. New York, NY: Reinhold.
- Green, R.H. 1979. *Sampling Design and Statistical Methods for Environmental Biologists*. New York, NY: Wiley.
- Hamelink, J.L.; Landrum, P.F.; Bergman, H.L.; Benson, W.H. (eds). 1994. *Bioavailability: Physical, Chemical, and Biological Interactions*. Boca Raton, FL: CRC Press, Inc., Lewis Publishers.
- Hill, I.R.; Matthiessen, P.; Heimbach, F. (eds.). 1993. *Guidance Document on Sediment Toxicity Tests and Bioassays for Freshwater and Marine Environments*. From the Workshop on Sediment Toxicity Assessment, Renesse, The Netherlands, November 8-10, 1993. Amsterdam, The Netherlands: Society of Environmental Toxicology and Chemistry - Europe.
- *Hill, A.B. 1965. The environment and disease: Association or causation? *Proceed. Royal Soc. Med.* 58: 285-300.
- *Hoffman, D.J.; Rice, C.P.; Kubiak, T.J. 1996. PCBs and dioxins in birds. In: Beyer, W.N.; Heinz, G.H.; Redmon-Norwood, A.R. (eds.). *Environmental Contaminants in Wildlife: Interpreting Tissue Concentrations*. A Special Publication of the Society of

Environmental Toxicology and Chemistry (SETAC), La Point, T.W. (series ed.). Boca Raton, FL: CRC Press, Inc., Lewis Publishers. pp. 165-208.

- Howard, P.H.; Jarvis, W.F.; Meyland, W.M.; Michalenko, E.M. 1991. *Handbook of Environmental Degradation Rates*. Boca Raton, FL: CRC Press, Inc., Lewis Publishers.
- Hugget, R.J.; Kimerle, R.A.; Mehrle, P.M., Jr.; Bergman, H.L. 1992. *Biomarkers: Biochemical, Physiological, and Histological Markers of Anthropogenic Stress*. A Special Publication of the Society of Environmental Toxicology and Chemistry (SETAC), Ward, C.H.; Walton, B.T; La Point, T.W. (series eds.). Boca Raton, FL: CRC Press, Inc., Lewis Publishers.
- Kabata-Pendias, A.; Pendias, H. 1984. *Trace Elements in Soils and Plants*. Boca Raton, FL: CRC Press, Inc.
- *Kamrin, M.A.; Ringer, R.K. 1996. Toxicological implications of PCB residues in mammals. In: Beyer, W.N.; Heinz, G.H.; Redmon-Norwood, A.R. (eds.). *Environmental Contaminants in Wildlife: Interpreting Tissue Concentrations*. A Special Publication of the Society of Environmental Toxicology and Chemistry (SETAC), La Point, T.W. (series ed.). Boca Raton, FL: CRC Press, Inc., Lewis Publishers. pp 153-164.
- Keith, L.H. (ed.). 1996. *EPA's Sampling and Analysis Methods Database; Version 2.0*. Boca Raton, FL: CRC Press, Inc., Lewis Publishers.
- Keith, L.H. (ed.). 1988. *Principles of Environmental Sampling*. American Chemical Society.
- Kendall, R.J.; Lacher, T.E. (eds.). 1994. *Wildlife Toxicology and Population Modeling: Integrated Studies of Agroecosystems*. A Special Publication of the Society of Environmental Toxicology and Chemistry (SETAC), La Point, T.W. (series ed.). Boca Raton, FL: CRC Press, Inc., Lewis Publishers.
- *Kenzaburo, T. 1986. Lead. In: Friberg, L.; Norberg, G.F.; Vouk, V.B (eds.). *Handbook on the Toxicology of Metals*. New York, NY: Elsevier.
- *Klemm, D.J.; Lewis, P.A.; Fulk, F.; Lazorchak, J.M. 1990. *Macroinvertebrate Field and Laboratory Methods for Evaluating the Biological Integrity of Surface Waters*. Washington, DC: U.S. Environmental Protection Agency. EPA/600/4-90/030.
- Kraus, M.L. 1989. Bioaccumulation of heavy metals in pre-fledgling tree swallows, *Tachycineta bicolor*. Environ. Contam. Toxicol. 43: 407-414.

- Krebs, C.J. 1978. *Ecology: The Experimental Analysis of Distribution and Abundance*; Second Edition. New York, NY: Harper & Row.
- *Krebs, C.J.; Valiela, I.; Harvey, G.R.; Teal, J.M. 1974. Reduction of field populations of fiddler crabs by uptake of chlorinated hydrocarbons. *Mar. Pollut. Bull.* 5: 140-142.
- *Kubiak, T.J.; Harris, H.J.; Smith, L.M.; et al. 1989. Microcontaminants and reproductive impairment of the Forster's tern on Green Bay, Lake Michigan—1983. *Arch. Environ. Contam. Toxicol.* 18: 706-727.
- Landis, W.G.; Yu, M. 1995. *Introduction to Environmental Toxicology: Impacts of Chemicals upon Ecological Systems*. Boca Raton, FL: CRC Press, Inc., Lewis Publishers.
- Landis, W.G.; Hughes, J.S.; Lewis, M.A. (eds.). 1993. *Environmental Toxicity and Risk Assessment*. Philadelphia, PA: American Society for Testing and Materials.
- *Long, E.R.; Chapman, P.M. 1985. A sediment quality triad: measures of sediment contamination, toxicity, and infaunal community composition in Puget Sound. *Mar. Pollut. Bull.* 16: 405-415.
- Lyon, J.G. 1993. *Practical Handbook for Wetland Identification and Delineation*. Boca Raton, FL: CRC Press, Inc., Lewis Publishers.
- Manahan, S. 1994. *Environmental Chemistry*; Sixth Edition. Boca Raton, FL: CRC Press, Inc., Lewis Publishers.
- Maughan, J.T. 1993. *Ecological Assessment of Hazardous Waste Sites*. New York, NY: Van Nostrand Reinhold.
- *McNamara, B.P. 1976. Concepts in health evaluation of commercial and industrial chemicals. In: Mehlman, M.A.; Shapiro, R.E., and Blumenthal, H. (eds.), *Advances in Modern Toxicology, Volume 1, Part 1: New Concepts in Safety Evaluation*. pp. 61-140. Washington, DC: Hemisphere Publishing Corporation.
- Mead, R. 1988. *The Design of Experiments*. Cambridge, UK: Cambridge University Press.
- Moltmann, J.F.; Römbke, J. 1996. *Applied Ecotoxicology*. Boca Raton, FL: CRC Press, Inc., Lewis Publishers.
- Morgan, B.J. 1993. *Analysis of Quantal Response Data*. London, UK: Chapman and Hall.
- Mudroch, A.; Azcue, J.M. 1995. *Manual of Aquatic Sediment Sampling*. Boca Raton, FL: CRC Press, Inc., Lewis Publishers.

- Mudroch, A; MacKnight, S.D. (eds.). 1994. *Handbook of Techniques for Aquatic Sediment Sampling*; Second Edition. Boca Raton, FL: CRC Press, Inc., Lewis Publishers.
- Murdoch, A.; MacKnight, S.D. (eds.). 1991. *CRC Handbook of Techniques for Aquatic Sediments Sampling*. Boca Raton, FL: CRC Press.
- National Oceanic and Atmospheric Administration (NOAA). 1987. *Guidelines and Recommendations for Using Bioassessment in the Superfund Remedial Process*. Seattle, WA: Ocean Assessments Division. Prepared by Christopherson, S., and Field, L.J., National Oceanic and Atmospheric Administration, and Dexter, R.N., E.V.S. Consultants.
- *National Research Council (NRC). 1994. *Science and Judgment in Risk Assessment*. Washington, DC: National Academy Press.
- *National Research Council (NRC). 1993. *Issues in Risk Assessment*. Washington, DC: National Academy Press.
- *National Research Council (NRC). 1983. *Risk Assessment in the Federal Government: Managing the Process*. Washington, DC: National Academy Press.
- *Nebeker, A.V.; Cairns, M.A.; Wise, C.M. 1984. Relative sensitivity of *Chironomus tentans* life stages to copper. *Environ. Toxicology and Chemistry* 3: 151-158.
- Neilson, A.H. 1994. *Organic Chemicals in the Aquatic Environment: Distribution, Persistence, and Toxicity*. Boca Raton, FL: CRC Press, Inc., Lewis Publishers.
- Newman, M.C. 1995. *Quantitative Methods in Aquatic Ecotoxicology*. Boca Raton, FL: CRC Press, Inc., Lewis Publishers.
- Newman, M.C.; McIntosh, A.W. (eds.). 1991. *Metal Ecotoxicology: Concepts and Applications*. Boca Raton, FL: CRC Press, Inc., Lewis Publishers.
- Oak Ridge National Laboratory (ORNL). 1994. *Manual for PC-Data Base Screening Benchmarks for Ecological Risk Assessment*. Environmental Sciences Division, Health Sciences Research Division. Prepared by Martín Marietta Energy Systems, Inc., for the U.S. Department of Energy. ORNL/TM-12898.
- Oak Ridge National Laboratory (ORNL). 1994. *Toxicological Benchmarks for Screening Contaminants of Potential Concern for Effects on Sediment-Associated Biota: 1994 Revision*. Prepared by Hull, R.N.; Suter, G.W., II; Energy Systems Environmental Restoration Program, ORNL Environmental Restoration Program (managed by Martin Marietta Energy Systems, Inc., for the U.S. Department of Energy). ES/ER/TM-95/R1.

- Oak Ridge National Laboratory (ORNL). 1994. *Toxicological Benchmarks for Screening Potential Contaminants of Concern for Effects on Aquatic Biota: 1994 Revision*. Prepared by Suter, G.W., II; Mabrey, J.B.; ORNL Environmental Sciences Division, for the U.S. Department of Energy. ES/ER/TM-96/R1.
- Oak Ridge National Laboratory (ORNL). 1994. *Toxicological Benchmarks for Wildlife: 1994 Revision*. Prepared by Opresko, D. M., Sample, B., E., and Suter, G. W. II, ORNL Environmental Sciences Division, for the U.S. Department of Energy. ES/ER/TM-86/R1.
- Oak Ridge National Laboratory (ORNL). 1994. *Toxicological Benchmarks for Screening Potential Contaminants of Concern for Effects on Terrestrial Plants: 1994 Revision*. Prepared by Will, M. E., and Suter, G. W. II, ORNL Environmental Sciences Division, for the U.S. Department of Energy. ES/ER/TM-85/R1.
- Ostrander, G. (ed.). 1996. *Handbook of Aquatic Toxicology Methods*. Boca Raton, FL: CRC Press, Inc., Lewis Publishers.
- Ott, W.R. 1995. *Environmental Statistics and Data Analysis*. Boca Raton, FL: CRC Press, Inc., Lewis Publishers.
- Pacific Northwest National Laboratory (PNNL). 1997. *Using the Data Quality Objectives Process During the Design and Conduct of Ecological Risk Assessments*. Prepared by Bilyard, G.R.; Beckert, H.; Bascietto, J.J.; Abrams, C.W.; Dyer, S.A.; Haselow, L.A.; PNNL for the U.S. Department of Energy, Office of Environmental Policy and Health. DOE/EH-0544.
- Pain, D.J. 1995. Lead in the environment. In: *Handbook of Ecotoxicology*. pp 356-391.
- Parker, S.P. (ed.). 1994. *Dictionary of Scientific and Technical Terms*; Fifth Edition. New York, NY: McGraw-Hill.
- *Pascoe, D.; Williams, K.A.; Green, D.W.J. 1989. Chronic toxicity of cadmium to *Chironomus riparius* Meigen - effects upon larval development and adult emergence. *Hydrobiologia* 175: 109-115.
- *Phillips, D.H. 1978. The use of biological indicator organisms to quantitate organochlorine pollutants in aquatic environments – a review. *Environ. Pollut.* 16: 167-227.
- *Phillips, D.H. 1977. The use of biological indicator organisms to monitor trace metal pollution in marine and estuarine environments – a review. *Environ. Pollut.* 13: 281-317.

- Ramamoorthy, S.; Baddaloo, E.G. 1995. *Handbook of Chemical Toxicity Profiles of Biological Species; Volume 1: Aquatic Species*. Boca Raton, FL: CRC Press, Inc., Lewis Publishers.
- Rand, G.M.; Petrocelli, S.R. 1985. *Fundamentals of Aquatic Toxicology. Methods and Applications*. New York, NY: McGraw Hill.
- Renzoni, A.; Fossi, M.C.; Lari, L.; Mattei, N. (eds.). 1994. *Contaminants in the Environment. A Multidisciplinary Assessment of Risks to Man and Other Organisms*. Boca Raton, FL: CRC Press, Inc., Lewis Publishers.
- *Rice, C.P.; O'Keefe, P. 1995. Sources, pathways, and effects of PCBs, dioxins, and dibenzofurans. In: Hoffman, D.J.; Rattner, B.A.; Burton, G.A. Jr.; Cairns, J., Jr. (eds.). *Handbook of Ecotoxicology*. Ann Arbor, MI: CRC Press, Inc., Lewis Publishers.
- Ricklefs, R.E. 1990. *Ecology. Second Edition*. New York, NY: W.H. Freeman.
- *Ringer, R.K.; Aulerich, R.J.; Zabik, M. 1972. Effect of dietary polychlorinated biphenyls on growth and reproduction of mink. Extended abstract. ACS (American Chemical Society) 164th Annu. Meet. 12: 149-154.
- *Roy F. Weston, Inc. 1994. Analytical methods/standard operating procedures for tissue analysis. Prepared for U.S. EPA Environmental Response Team, Edison, NJ.
- Siegel, S. 1956. *Non-parametric Statistics*. New York, NY: McGraw-Hill.
- Sokal, R.R.; Rohlf, F.J. 1981. *Biometry. Second Edition*. New York, NY: W.H. Freeman.
- Sullivan, T.F. 1993. *Environmental Regulatory Glossary*. Government Institutes, Inc.
- Suter, G.W., II. 1993. *Ecological Risk Assessment*. Ann Arbor, MI: Lewis Publishers.
- Talmage, S.S.; Walton, B.T. 1991. Small mammals as monitors of environmental contaminants. *Reviews of Environmental Contamination and Toxicology* 119: 95.
- Trapp, S.; McFarlane, J.C. (eds.). 1995. *Plant Contamination: Modeling and Simulation of Organic Chemical Processes*. Boca Raton, FL: CRC Press, Inc., Lewis Publishers.
- U.S. Department of the Interior (U.S. DOI). 1991. Plant toxicity testing with sediment and marsh soils. Technical Report NPS/NRWRD/NRTR-91/03.

- U.S. Department of the Interior (U.S. DOI). 1987. *Guidance on Use of Habitat Evaluation Procedures and Suitability Index Models for CERCLA Application*. Washington, DC: U.S. Fish and Wildlife Service, National Ecology Center; PB86-100151.
- *U.S. Environmental Protection Agency (U.S. EPA). 1997. *Representative Sampling Guidance Document, Volume 3: Ecological, Draft*. Edison, NJ: Environmental Response Team Center, Office of Emergency and Remedial Response.
- *U.S. Environmental Protection Agency (U.S. EPA). 1996a. *Proposed Guidelines for Ecological Risk Assessment*. Cincinnati, OH: Office of Research and Development Publications, Technology Transfer and Support Division, August. EPA/630/R-95/002B.
- *U.S. Environmental Protection Agency (U.S. EPA). 1996b. *Proposed Guidelines for Carcinogen Risk Assessment*. Washington, DC: Office of Research and Development, April. EPA/600/P-92/003C.
- *U.S. Environmental Protection Agency (U.S. EPA). 1996c. *Ecotox Thresholds. ECO Update, Interim Bulletin, Volume 3, Number 2*. Washington, DC: Office of Emergency and Remedial Response, Hazardous Site Evaluation Division; Publication 9345.0-12FSI; EPA/540/F-95/038; NTIS PB95-963324.
- *U.S. Environmental Protection Agency (U.S. EPA). 1995a. *Great Lakes Water Quality Initiative Criteria Documents for the Protection of Wildlife*. Washington, DC: Office of Water. EPA/820/B-95/008.
- *U.S. Environmental Protection Agency (U.S. EPA). 1995b. *Ecological Significance and Selection of Candidate Assessment Endpoints. ECO Update, Intermittent Bulletin, Volume 3, Number 1*. Washington, DC: Office of Emergency and Remedial Response, Hazardous Site Evaluation Division; Publication 9345.0-11FSI; EPA/540/F-95/037; NTIS PB95-963323.
- *U.S. Environmental Protection Agency (U.S. EPA). 1995c. *Land Use in the CERCLA Remedy Selection Process*. May 25 Memorandum from Elliot P. Laws, Assistant Administrator, to EPA Regional staff. OSWER Directive No. 9355:7-04.
- *U.S. Environmental Protection Agency (U.S. EPA). 1995d. *Great Lakes Water Quality Initiative Technical Support Document for the Procedure to Determine Bioaccumulation Factors*. Washington, DC: Office of Water; EPA/820/B-95/005.
- *U.S. Environmental Protection Agency (U.S. EPA). 1995e. *Great Lakes Water Quality Initiative Criteria Documents for the Protection of Aquatic Life in Ambient Water*. Washington, DC: Office of Water; EPA/820/B-95/004.

- *U.S. Environmental Protection Agency (U.S. EPA). 1995f. *EPA Risk Characterization Policy*. March 21 Memorandum from Carol Browner, Administrator, to EPA staff. Washington, DC: Office of the Administrator.
- *U.S. Environmental Protection Agency (U.S. EPA). 1995g. *Technical Support Document for the Hazardous Waste Identification Rule: Risk Assessment for Human and Ecological Receptors, Volume I*. Washington, DC: Prepared for the Office of Solid Waste under Contract No. 68-D2-0065, 68-W3-0028; August.
- *U.S. Environmental Protection Agency (U.S. EPA). 1995h. *Technical Support Document for the Hazardous Waste Identification Rule: Risk Assessment for Human and Ecological Receptors, Volume II*. Washington, DC: Prepared for the Office of Solid Waste under Contract No. 68-D2-0065, 68-W3-0028; August.
- U.S. Environmental Protection Agency (U.S. EPA). 1995. *Ecological Risk: A Primer for Risk Managers*. Washington, DC: EPA/734/R-95/001.
- U.S. Environmental Protection Agency (U.S. EPA). 1995. *Draft Science Policy Council Statement on EPA Policy: Cumulative Risk Framework, With a Focus on Improved Characterization of Risks for Multiple Endpoints, Pathways, Sources, and Stressors*. Washington, DC: Science Policy Council.
- *U.S. Environmental Protection Agency (U.S. EPA). 1994a. Memorandum from Carol Browner, Administrator, to Assistant Administrators concerning "Toward a Place-Driven Approach: The Edgewater Consensus on an EPA Strategy for Ecosystem Protection. May 24.
- *U.S. Environmental Protection Agency (U.S. EPA). 1994b. *Using Toxicity Tests in Ecological Risk Assessment. ECO Update, Intermittent Bulletin, Volume 2, Number 1*. Washington, DC: Office of Emergency and Remedial Response, Hazardous Site Evaluation Division; Publication 9345.0-05I; EPA/540/F-94/012; NTIS PB94-963303.
- *U.S. Environmental Protection Agency (U.S. EPA). 1994c. *Catalogue of Standard Toxicity Tests for Ecological Risk Assessment. ECO Update, Intermittent Bulletin, Volume 2, Number 2*. Washington, DC: Office of Emergency and Remedial Response, Hazardous Site Evaluation Division; Publication 8345.0-05I; EPA/540/F-94/013; NTIS PB94-963304.
- *U.S. Environmental Protection Agency (U.S. EPA). 1994d. *Field Studies for Ecological Risk Assessment. ECO Update, Intermittent Bulletin, Volume 2, Number 3*. Washington, DC: Office of Emergency and Remedial Response, Hazardous Site Evaluation Division; Publ. 9345.0-05I; EPA/540/F-94/014; NTIS PB94-963305.

- *U.S. Environmental Protection Agency (U.S. EPA). 1994e. *Selecting and Using Reference Information in Superfund Ecological Risk Assessments. ECO Update, Intermittent Bulletin, Volume 2, Number 4.* Washington, DC: Office of Emergency and Remedial Response, Hazardous Site Evaluation Division; Publication 9345.10I; EPA/540/F-94/050; NTIS PB94-963319.
- *U.S. Environmental Protection Agency (U.S. EPA). 1994f. *Guidance for the Data Quality Objectives Process*; EPA QA/G-4. Washington, DC: Quality Assurance Management Staff; Final, September.
- *U.S. Environmental Protection Agency (U.S. EPA). 1994g. *Establishing Background Levels.* Quick Reference Fact Sheet. Washington, DC: Office of Solid Waste and Emergency Response. OSWER Directive 9285.7-19FS. Publication PB94-963313; EPA/540/F-94/030.
- *U.S. Environmental Protection Agency (U.S. EPA). 1994h. *Methods for Measuring the Toxicity and Bioaccumulation of Sediment-associated Contaminants with Freshwater Invertebrates.* Washington, DC: Office of Research and Development. EPA 600/R-94/024.
- U.S. Environmental Protection Agency (U.S. EPA). 1994. *Peer Review Workshop Report on Ecological Risk Assessment Issue Papers.* Washington, DC: Office of Research and Development, Risk Assessment Forum; EPA/630/R-94/008.
- U.S. Environmental Protection Agency (U.S. EPA). 1994. *A Review of Ecological Assessment Case Studies from a Risk Assessment Perspective, Volume II.* Washington, DC: Office of Research and Development, Risk Assessment Forum; EPA/630/R-94/003.
- U.S. Environmental Protection Agency (U.S. EPA). 1994. *Ecological Risk Assessment Issue Papers.* Washington, DC: Office of Research and Development, Risk Assessment Forum; EPA/630/R-94/009.
- U.S. Environmental Protection Agency (U.S. EPA). 1994. *Managing Ecological Risks at EPA: Issues and Recommendations for Progress.* Washington, DC: Office of Research and Development, Office of Policy, Planning, and Evaluation; EPA/600/R-94/183.
- U.S. Environmental Protection Agency (U.S. EPA). 1994. *Methods for Measuring the Toxicity of Sediment-associated Contaminants with Estuarine and Marine Amphipods.* Washington, DC: Office of Research and Development. EPA 600/R-94/025.

- *U.S. Environmental Protection Agency (U.S. EPA). 1993a. *Wildlife Exposure Factors Handbook Volume I*. Washington, DC: Office of Research and Development; EPA/600/R-93/187a.
- *U.S. Environmental Protection Agency (U.S. EPA). 1993b. *Wildlife Exposure Factors Handbook Volume II: Appendix*. Washington, DC: Office of Research and Development; EPA/600/R-93/187b.
- *U.S. Environmental Protection Agency (U.S. EPA). 1993c. *Data Quality Objectives Process for Superfund*. Washington, DC: Office of Emergency and Remedial Response; Interim Final Guidance; EPA/540/G-93/071.
- *U.S. Environmental Protection Agency (U.S. EPA). 1993d. *Data Quality Objectives Process for Superfund. Workbook*. Washington, DC: Office of Emergency and Remedial Response; EPA/540/R-93/078.
- *U.S. Environmental Protection Agency (U.S. EPA). 1993e. *Wildlife Criteria Portions of the Proposed Water Quality Guidance for the Great Lakes System*. Washington, DC: Office of Water; EPA/822/R-93/006.
- *U.S. Environmental Protection Agency (U.S. EPA). 1993f. *Guidance for Planning for Data Collection in Support of Environmental Decision Making Using the Data Quality Objectives Process*. Interim Final. Quality Assurance Management Staff; EPA QA/G-4.
- U.S. Environmental Protection Agency (U.S. EPA). 1993. *A Review of Ecological Assessment Case Studies from a Risk Assessment Perspective*. Washington, DC: Risk Assessment Forum; EPA/630/R-92/005.
- U.S. Environmental Protection Agency (U.S. EPA). 1993. *Technical Basis for Deriving Sediment Quality Criteria for Nonionic Organic Contaminants for the Protection of Benthic Organisms by Using Equilibrium Partitioning*. Washington, DC: Office of Water; EPA/822/R-93/011.
- U.S. Environmental Protection Agency (U.S. EPA). 1993. *Guidelines for Deriving Site-Specific Sediment Quality Criteria for the Protection of Benthic Organisms*. Washington, DC: Office of Water; EPA/822/R-93/017.
- *U.S. Environmental Protection Agency (U.S. EPA). 1992a. *Framework for Ecological Risk Assessment*. Washington, DC: Risk Assessment Forum; EPA/630/R-92/001.

- *U.S. Environmental Protection Agency (U.S. EPA). 1992b. *Developing a Work Scope for Ecological Assessments. ECO Update, Intermittent Bulletin, Volume 1, Number 4.* Washington, DC: Office of Emergency and Remedial Response, Hazardous Site Evaluation Division; Publ. 9345.0-05I.
- *U.S. Environmental Protection Agency (U.S. EPA). 1992c. *The Role of Natural Resource Trustees in the Superfund Process. ECO Update, Intermittent Bulletin, Volume 1, Number 3.* Washington, DC: Office of Emergency and Remedial Response, Hazardous Site Evaluation Division; Publ. 9345.0-05I.
- *U.S. Environmental Protection Agency (U.S. EPA). 1992d. *Briefing the BTAG: Initial Description of Setting, History, and Ecology of a Site. ECO Update, Intermittent Bulletin, Volume 1, Number 5.* Washington, DC: Office of Emergency and Remedial Response, Hazardous Site Evaluation Division; Publ. 9345.0-05I.
- *U.S. Environmental Protection Agency (U.S. EPA). 1992e. *Draft Report: A Cross-species Scaling Factor for Carcinogen Risk Assessment Based on Equivalence of mg/kg^{3/4} per day; Notice. Federal Register.* 57(109): 24152-24173 (June 5).
- *U.S. Environmental Protection Agency (U.S. EPA). 1992f. *Guidance on Risk Characterization for Risk Managers and Risk Assessors.* February 26 Memorandum from F. Henry Habicht II, Deputy Administrator, to EPA Assistant Administrators and Regional Administrators. Washington, DC: Office of the Deputy Administrator.
- U.S. Environmental Protection Agency (U.S. EPA). 1992. *Sediment Classification Methods Compendium.* Washington, DC: Office of Water; EPA/823/R-092/006.
- U.S. Environmental Protection Agency (U.S. EPA). 1992. *Superfund Ecological Assessment Process Case Studies.* Washington, DC: Office of Emergency and Remedial Response, Hazardous Site Evaluation Division, Toxics Integration Branch. Prepared by The Cadmus Group, Incorporated.
- U.S. Environmental Protection Agency (U.S. EPA). 1992. *Peer Review Workshop Report on a Framework for Ecological Risk Assessment.* Washington, DC: Risk Assessment Forum; EPA/625/3-91/022.
- U.S. Environmental Protection Agency (U.S. EPA). 1992. *Report on the Ecological Risk Assessment Guidelines Strategic Planning Workshop.* Washington, DC: Risk Assessment Forum; EPA/630/R-92/002.
- U.S. Environmental Protection Agency (U.S. EPA). 1992. *Guidelines for Exposure Assessment. Federal Register.* 57: 22888-22938 (May 29).

- U.S. Environmental Protection Agency (U.S. EPA). 1992. *Dermal Exposure - Principles and Applications*; Final; Washington, DC: Office of Health and Environmental Assessment; EPA/600/8-91/011B.
- U.S. Environmental Protection Agency (U.S. EPA). 1992. *Science Advisory Board's Review of the Draft Final Exposure Assessment Guidelines* (SAB Final Review Draft, August 1991). Washington, DC: Science Advisory Board; EPA/SAB/IAQC-92/015.
- U.S. Environmental Protection Agency (U.S. EPA). 1992. *Interim Guidance on the Interpretation and Implementation of Aquatic Life Criteria for Metals*. Washington, DC: Office of Water, Office of Science and Technology, Health and Ecological Criteria Division.
- *U.S. Environmental Protection Agency (U.S. EPA). 1991a. *Risk Assessment Guidance for Superfund: Volume I - Human Health Evaluation Manual (Part B, Development of Risk-Based Preliminary Remediation Goals), Interim*. Washington, DC: Office of Emergency and Remedial Response; 9285.7-01B.
- *U.S. Environmental Protection Agency (U.S. EPA). 1991b. *Risk Assessment Guidance for Superfund: Volume I - Human Health Evaluation Manual (Part C, Risk Evaluation of Remedial Alternatives), Interim*. Washington, DC: Office of Emergency and Remedial Response; 9285.7-01C.
- *U.S. Environmental Protection Agency (U.S. EPA). 1991c. *Ecological Assessment of Superfund Sites: An Overview. ECO Update, Intermittent Bulletin, Volume 1, Number 2*. Washington, DC: Office of Emergency and Remedial Response, Hazardous Site Evaluation Division; Publ. 9345.0-05I.
- *U.S. Environmental Protection Agency (U.S. EPA). 1991d. *The Role of BTAGs in Ecological Assessment. ECO Update, Intermittent Bulletin, Volume 1, Number 1*. Washington, DC: Office of Emergency and Remedial Response, Hazardous Site Evaluation Division; Publ. 9345.0-05I.
- U.S. Environmental Protection Agency (U.S. EPA). 1991. *Guidance on Oversight of Potentially Responsible Party Remedial Investigations and Feasibility Studies, Volume 1*. Office of Solid Waste and Emergency Response, Washington, DC. OSWER Directive 9835.1(c). EPA/540/G-91/010a.
- U.S. Environmental Protection Agency (U.S. EPA). 1991. *Guidance on Oversight of Potentially Responsible Party Remedial Investigations and Feasibility Studies, Volume 2, Appendices*. Office of Solid Waste and Emergency Response, Washington, DC. OSWER Directive 9835.1(c). EPA/540/G-91/010b.

- U.S. Environmental Protection Agency (U.S. EPA). 1991. *Methods for Measuring the Acute Toxicity of Effluents and Receiving Waters to Freshwater and Marine Organisms*; Fourth Edition; Washington, DC: Office of Research and Development; EPA/600/4-90/027.
- U.S. Environmental Protection Agency (U.S. EPA). 1991. *Technical Support Document for Water Quality-based Toxics Control*. Washington, DC: Office of Water; EPA/505/2-90/001.
- U.S. Environmental Protection Agency (U.S. EPA). 1991. *Short-term Methods for Estimating the Chronic Toxicity of Effluents and Receiving Waters to Freshwater Organisms; Third Edition*. Washington, DC: Office of Research and Development; EPA/600/4-91/002.
- U.S. Environmental Protection Agency (U.S. EPA). 1991. *Short-term Methods for Estimating the Chronic Toxicity of Effluents and Receiving Waters to Marine and Estuarine Organisms*; Second Edition. Washington, DC: Office of Research and Development; EPA/600/4-91/003.
- U.S. Environmental Protection Agency (U.S. EPA). 1991. *Methods for Aquatic Toxicity Identification Evaluations: Phase I, Toxicity Characterization Procedures*. Duluth, MN: Office of Research and Development: Environmental Research Laboratory; EPA/600/6-91/003.
- U.S. Environmental Protection Agency (U.S. EPA). 1991. *Supplemental Methods and Status Reports for Short-term Saltwater Toxicity Tests*. G. Morrison and G. Chapman. ERL contribution No. 1199. Narragansett, RI: Environmental Research Laboratory.
- U.S. Environmental Protection Agency (U.S. EPA). 1991. *Assessment and Control of Bioconcentratable Contaminants in Surface Waters*. June 1989 Draft prepared by EPA's National Effluent Toxicity Assessment Center, Environmental Research Laboratory - Duluth, MN. Washington, DC: Office of Water Regulations and Standards; and Cincinnati, OH: Office of Health Effects Assessment.
- U.S. Environmental Protection Agency (U.S. EPA). 1991. *Role of the Baseline Risk Assessment in Superfund Remedy Selection Decisions*. Don R. Clay, Assistant Administrator, Office of Solid Waste and Emergency Response. Washington, DC: Office of Solid Waste and Emergency Response Directive 9355.0-30.
- U.S. Environmental Protection Agency (U.S. EPA). 1991. *Summary Report on Issues in Ecological Risk Assessment*. Washington, DC: Risk Assessment Forum; EPA/625/3-91/018.

- U.S. Environmental Protection Agency (U.S. EPA). 1991. *Ecological Exposure and Effects of Airborne Toxic Chemicals: An Overview*. Corvallis, OR: Office of Research and Development, Environmental Research Laboratory; EPA/600/3-91/001.
- U.S. Environmental Protection Agency (U.S. EPA). 1991. *Technical Support Document for Water Quality-based Toxics Control*. Washington, DC: Office of Water Regulations and Standards; EPA/440/4-85/032.
- *U.S. Environmental Protection Agency (U.S. EPA). 1990a. *Macroinvertebrate Field and Laboratory Methods for Evaluating the Biological Integrity of Surface Waters*. Washington, DC: Office of Water; EPA/600/4-90/030.
- *U.S. Environmental Protection Agency (U.S. EPA). 1990b. *Hazard Ranking System; Final Rule*. Federal Register. 55: 51532-51662 (December 14).
- U.S. Environmental Protection Agency (U.S. EPA). 1990. *Guidance for Data Useability in Risk Assessment*. Washington, DC: Office of Solid Waste and Emergency Response; EPA/540/G-90/008.
- U.S. Environmental Protection Agency (U.S. EPA). 1990. *EPA Oversight of Remedial Designs and Remedial Actions Performed by PRPs*. Quick Reference Fact Sheet. Washington, DC: Office of Emergency and Remedial Response, Hazardous Site Control Division; Publication 9355.5-01/FS.
- U.S. Environmental Protection Agency (U.S. EPA). 1990. *Guidance Manual for Evaluation of Laboratories Performing Aquatic Toxicity Tests*. Washington, DC: Office of Research and Development; EPA/600/4-90/031.
- U.S. Environmental Protection Agency (U.S. EPA). 1990. *Biological Criteria, National Program Guidance for Surface Waters*. Washington, DC: Office of Water Regulations and Standards; EPA/440/5-90/004.
- U.S. Environmental Protection Agency (U.S. EPA). 1990. *Managing Contaminated Sediments: EPA Decision-Making Processes*. Washington, DC: Sediment Oversight Technical Committee; EPA/506/6-90/002.
- U.S. Environmental Protection Agency (U.S. EPA). 1990. National guidance: wetlands and nonpoint source control programs. Memorandum from Martha G. Prothro, Director, Office of Water Regulations and Standards; Washington, DC: Office of Water (June 18).
- U.S. Environmental Protection Agency (U.S. EPA). 1990. *Water Quality Standards for Wetlands--National Guidance*. Washington, DC: Office of Water Regulations and Standards; EPA/440/S-90/011.

- *U.S. Environmental Protection Agency (U.S. EPA). 1989a. *Risk Assessment Guidance for Superfund: Volume 1 - Human Health Evaluation Manual, Interim Final*. Washington, DC: Office of Solid Waste, Office of Emergency and Remedial Response; EPA/540/1-89/002.
- *U.S. Environmental Protection Agency (U.S. EPA). 1989b. *Risk Assessment Guidance for Superfund: Volume 2 - Environmental Evaluation Manual, Interim Final*. Washington, DC: Office of Solid Waste and Emergency Response; EPA/540/1-89/001A.
- *U.S. Environmental Protection Agency (U.S. EPA). 1989c. *Rapid Bioassessment Protocols for Use in Streams and Rivers: Benthic Macroinvertebrates and Fish*. Washington, DC: Office of Water; EPA/444/4-89/001 (Prepared by Plafkin, J.L.; Barbour, M.T.; Porter, K.D.; Gross, S.K.; Hughes, R.M.).
- U.S. Environmental Protection Agency (U.S. EPA). 1989. *Exposure Factors Handbook*. Washington, DC: Office of Research and Development, Office of Health and Environmental Assessment. EPA/600/8-89/049.
- U.S. Environmental Protection Agency (U.S. EPA). 1989. *Briefing Report to the EPA Science Advisory Board on the Equilibrium Partitioning Approach to Generating Sediment Quality Criteria*. Washington, DC: Office of Water Regulations and Standards; EPA/440/5-89/002.
- U.S. Environmental Protection Agency (U.S. EPA). 1989. *Survey of State Water Quality Standards for Wetlands*. Washington, DC: Office of Wetlands Protection.
- U.S. Environmental Protection Agency (U.S. EPA). 1989. *Report to the Sediment Criteria Subcommittee: Evaluation of the Apparent Effects Threshold (AET) Approach for Assessing Sediment Quality*. Washington, DC: Office of the Administrator, Science Advisory Board; SAB-EETFC-89-027.
- U.S. Environmental Protection Agency (U.S. EPA). 1989. *Sediment Classification Methods Compendium; Final Draft*. Washington, DC: Office of Water, Watershed Protection Division (June).
- U.S. Environmental Protection Agency (U.S. EPA). 1989. *Water Quality Criteria to Protect Wildlife Resources*. Corvallis, OR: Office of Research and Development, Environmental Research Laboratory; EPA/600/3-89/067.
- U.S. Environmental Protection Agency (U.S. EPA). 1989. *Ecological Assessment of Hazardous Waste Sites: A Field and Laboratory Reference*. Corvallis, OR: Office of Research and Development, Environmental Research Laboratory; EPA/600/3-89/013.

- U.S. Environmental Protection Agency (U.S. EPA). 1989. *Superfund Exposure Assessment Manual—Technical Appendix: Exposure Analysis of Ecological Receptors*. Athens, GA: Office of Research and Development, Environmental Research Laboratory (December).
- U.S. Environmental Protection Agency (U.S. EPA). 1989. *Protocols for Short-Term Toxicity Screening of Hazardous Waste Sites*. Office of Research and Development, Environmental Research Laboratory; EPA/600/3-88/029.
- U.S. Environmental Protection Agency (U.S. EPA). 1989. *Scoping Study of the Effects of Soil Contamination on Terrestrial Biota*. Washington, DC: Office of Toxic Substances.
- *U.S. Environmental Protection Agency (U.S. EPA). 1988a. *Guidance for Conducting Remedial Investigations and Feasibility Studies Under CERCLA*. Washington, DC: Office of Emergency and Remedial Response; OSWER Directive No. 9355.3-01.
- U.S. Environmental Protection Agency (U.S. EPA). 1988. *Estimating Toxicity of Industrial Chemicals to Aquatic Organisms Using Structure Activity Relationships*. Office of Toxic Substances, Washington, DC: EPA/560/6-88/001.
- U.S. Environmental Protection Agency (U.S. EPA). 1988. *CERCLA Compliance with Other Laws Manual, Part 1*. Washington, DC: Office of Emergency and Remedial Response; OSWER Directive 9234.1-01.
- U.S. Environmental Protection Agency (U.S. EPA). 1988. *Short-term Methods for Estimating the Chronic Toxicity of Effluents in Receiving Waters to Marine and Estuarine Organisms*. Cincinnati, OH: Office of Research and Development, Office of Environmental Monitoring and Support Laboratory; EPA/600/4-87/0928.
- U.S. Environmental Protection Agency (U.S. EPA). 1988. *Estimating Toxicity of Industrial Chemicals to Aquatic Organisms Using Structure Activity Relationships*. Washington, DC: Office of Toxic Substances; EPA/560/6-88/001.
- U.S. Environmental Protection Agency (U.S. EPA). 1988. *Short-term Methods for Estimating the Chronic Toxicity of Effluents in Receiving Waters to Marine and Estuarine Organisms*. Cincinnati, OH: Office of Research and Development, Environmental Monitoring and Support Laboratory; EPA/600/4-87/0928.
- U.S. Environmental Protection Agency (U.S. EPA). 1988. *Methods for Aquatic Toxicity Identification Evaluations: Phase II, Toxicity Identification Procedures*. Duluth, MN: Environmental Research Laboratory; EPA/600/3-88/035.

- U.S. Environmental Protection Agency (U.S. EPA). 1988. *Methods for Aquatic Toxicity Identification Evaluations: Phase III, Toxicity Confirmation Procedures*. Duluth, MN: Office of Research and Development, Environmental Research Laboratory; EPA/600/3-88/036.
- U.S. Environmental Protection Agency (U.S. EPA). 1988. *Superfund Exposure Assessment Manual*. Washington, DC: Office of Solid Waste and Emergency Response Directive 9285.5-1; EPA/540/1-88/001.
- *U.S. Environmental Protection Agency (U.S. EPA). 1987a. *Data Quality Objectives for Remedial Response Activities: Development Process*. Washington, DC: Office of Solid Waste and Emergency Response, Office of Emergency and Remedial Response and Office of Waste Programs Enforcement, OSWER Directive 9355.0-7B; EPA/540/G-87/003.
- U.S. Environmental Protection Agency (U.S. EPA). 1987. *Data Quality Objectives for Remedial Response Activities: Example Scenario: RI/FS Activities at a Site with Contaminated Soils and Ground Water*. Washington, DC: Office of Solid Waste and Emergency Response, Office of Emergency and Remedial Response and Office of Waste Programs Enforcement, OSWER Directive 9355.0-7B; EPA/540/G-87/004.
- U.S. Environmental Protection Agency (U.S. EPA). 1987. *Permit Writer's Guide to Water Quality-Based Permitting for Toxic Pollutants*. Washington, DC: Office of Water Regulations and Standards; EPA/440/4-87/005.
- U.S. Environmental Protection Agency (U.S. EPA). 1987. *Guidelines for Deriving Ambient Aquatic Life Advisory Concentrations*. Washington, DC: Office of Water Regulations and Standards (unpublished).
- U.S. Environmental Protection Agency (U.S. EPA). 1987. *A Compendium of Superfund Field Operations Methods*. Washington DC: Office of Solid Waste and Emergency Response, Office of Environmental and Remedial Response; EPA/540/P-87/001.
- U.S. Environmental Protection Agency (U.S. EPA). 1987. *Role of Acute Toxicity Bioassays in the Remedial Action Process at Hazardous Waste Sites*. Corvallis, OR: Office of Research and Development, Environmental Research Laboratory; EPA/600/8-87/044.
- U.S. Environmental Protection Agency (U.S. EPA). 1987. *Ecological Risk Assessment in the Office of Toxic Substances: Problems and Progress 1984-1987*. Washington, DC: Office of Toxic Substances, Health and Environmental Review Division (Author: Rodier, D.)

- *U.S. Environmental Protection Agency (U.S. EPA). 1986a. *Guidelines for the Health Risk Assessment of Chemical Mixtures*. Washington, DC: Office of Health and Environmental Assessment; EPA/600/8-87/045.
- U.S. Environmental Protection Agency (U.S. EPA). 1986. *Engineering Support Branch, Standard Operating Procedures and Quality Assurance Manual*. Region IV, Environmental Services Division.
- U.S. Environmental Protection Agency (U.S. EPA). 1986. *Guidelines for Deriving Numerical Criteria for the Protection of Aquatic Organisms and Their Uses*. Washington, DC: Office of Water Regulations and Standards.
- U.S. Environmental Protection Agency (U.S. EPA). 1986. *Quality Criteria for Water 1986*. Washington, DC: Office of Water Regulations and Standards; EPA/440/5-86/001.
- *U.S. Environmental Protection Agency (U.S. EPA). 1985a. *Ambient Water Quality Criteria for Copper-1984*. Washington, DC: Office of Water, Regulations and Standards, Criteria and Standards Division. EPA/440/5-84-031. PB85-227023.
- U.S. Environmental Protection Agency (U.S. EPA). 1985. *Development of Statistical Distributions of Ranges of Standard Factors Used in Exposure Assessments*. Washington, DC: Office of Health and Environmental Assessment, OHEA-E-161; EPA/600/8-85/010.
- U.S. Environmental Protection Agency (U.S. EPA). 1985. *Guide for Identifying Cleanup Alternatives at Hazardous Waste Sites and Spills*. Washington, DC: Office of Solid Waste and Emergency Response; EPA/600/3-83/063, NTIS PB86-144664.
- U.S. Environmental Protection Agency (U.S. EPA). 1985. *Methods for Measuring the Acute Toxicity of Effluents to Freshwater and Marine Organisms*. Cincinnati, OH: Office of Research and Development, Environmental Monitoring and Support Laboratory; EPA/600/4-85/013.
- U.S. Environmental Protection Agency (U.S. EPA). 1985. *Short-term Methods for Estimating the Chronic Toxicity of Effluents in Receiving Waters to Freshwater Organisms*. Cincinnati, OH: Office of Research and Development, Environmental Monitoring and Support Laboratory; EPA/600/4-85/014.
- *U.S. Environmental Protection Agency (U.S. EPA). 1984a. *Risk Assessment and Management: Framework for Decision Making*. Washington, DC: Office of Policy, Planning, and Evaluation; EPA/600/9-85/002.

- U.S. Environmental Protection Agency (U.S. EPA). 1984. *Estimating "Concern Levels" for Concentrations of Chemical Substances in the Environment*. Washington, DC: Office of Toxic Substances, Environmental Effects Branch.
- U.S. Environmental Protection Agency (U.S. EPA). 1984. *Technical Support Manual: Waterbody Surveys and Assessments for Conducting Use Attainability Analyses: Volume II: Estuarine Systems*. Washington, DC: Office of Water Regulations and Standards.
- U.S. Environmental Protection Agency (U.S. EPA). 1984. *Technical Support Manual: Waterbody Surveys and Assessments for Conducting Use Attainability Analyses: Volume III: Lake Systems*. Washington, DC: Office of Water Regulations and Standards.
- U.S. Environmental Protection Agency (U.S. EPA). 1983. *Technical Support Manual: Waterbody Surveys and Assessments for Conducting Use Attainability Analyses*. Washington, DC: Office of Water Regulations and Standards (November).
- U.S. Environmental Protection Agency (U.S. EPA). 1983. *Environmental Effects of Regulatory Concern Under TSCA: A Position Paper*. Washington, DC: Office of Toxic Substances, Health and Environmental Review Division (Author: Clements, R.G.)
- U.S. Environmental Protection Agency (U.S. EPA) and Department of the Army, U.S. Army Corps of Engineers (USACE). 1994. *Evaluation of Dredged Material Proposed for Discharge in Waters of the U.S.—Testing Manual (Draft); Inland Testing Manual*. Washington, DC: EPA Office of Water. EPA/823/B-94/002.
- Watras, C.J.; Huckabee, J.W. (eds.). 1995. *Mercury Pollution: Integration and Synthesis*. Boca Raton, FL: CRC Press, Inc., Lewis Publishers.
- *Weil, C.S.; McCollister, D.D. 1963. Relationship between short- and long-term feeding studies in designing an effective toxicity test. *Agr. Food Chem.* 11: 486-491.
- Wentsel, R.S.; LaPoint, T.W.; Simini, M.; Checkai, R.T.; Ludwig, D.; Brewer, L. 1994. *Procedural Guidelines for Ecological Risk Assessments at U.S. Army Sites, Volume I*. Aberdeen Proving Ground, MD: Edgewood Research, Development, and Engineering Center, U.S. Army Chemical and Biological Defense Command. Rept. No. ERDEC-TR-221.
- *Wren, C.D. 1991. Cause-effect linkages between chemicals and populations of mink (*Mustela vison*) and otter (*Lutra canadensis*) in the Great Lakes basin. *J. Toxicol. Environ. Health* 33: 549-585.

GLOSSARY

This glossary includes definitions from several sources. A superscript number next to a word identifies the reference from which the definition was adapted (listed at the end of the Glossary).

Abiotic.¹ Characterized by absence of life; abiotic materials include non-living environmental media (e.g., water, soils, sediments); abiotic characteristics include such factors as light, temperature, pH, humidity, and other physical and chemical influences.

Absorption Efficiency. A measure of the proportion of a substance that a living organism absorbs across exchange boundaries (e.g., gastrointestinal tract).

Absorbed Dose.² The amount of a substance penetrating the exchange boundaries of an organism after contact. Absorbed dose for the inhalation and ingestion routes of exposure is calculated from the intake and the absorption efficiency. Absorbed dose for dermal contact depends on the surface area exposed and absorption efficiency.

Accuracy.⁴ The degree to which a measurement reflects the true value of a variable.

Acute.⁵ Having a sudden onset or lasting a short time. An acute stimulus is severe enough to induce a response rapidly. The word acute can be used to define either the exposure or the response to an exposure (effect). The duration of an acute aquatic toxicity test is generally 4 days or less and mortality is the response usually measured.

Acute Response. The response of (effect on) an organisms which has a rapid onset. A commonly measured rapid-onset response in toxicity tests is mortality.

Acute Tests. A toxicity test of short duration, typically 4 days or less (i.e., of short duration relative to the lifespan of the test organism).

Administered Dose.² The mass of a substance given to an organism and in contact with an exchange boundary (i.e., gastrointestinal tract) per unit wet body weight (BW) per unit time (e.g., mg/kgBW/day).

Adsorption.¹⁴ Surface retention of molecules, atoms, or ions by a solid or liquid, as opposed to absorption, which is penetration of substances into the bulk of a solid or liquid.

Area Use Factor. The ratio of an organism's home range, breeding range, or feeding/foraging range to the area of contamination of the site under investigation.

Assessment Endpoint.⁶ An explicit expression of the environmental value that is to be protected.

Benthic Community.⁷ The community of organisms dwelling at the bottom of a pond, river, lake, or ocean.

Bioaccumulation.⁵ General term describing a process by which chemicals are taken up by an organism either directly from exposure to a contaminated medium or by consumption of food containing the chemical.

Biocumulation Factor (BAF).³ The ratio of the concentration of a contaminant in an organism to the concentration in the ambient environment at steady state, where the organism can take in the contaminant through ingestion with its food as well as through direct contact.

Bioassay.⁵ Test used to evaluate the relative potency of a chemical by comparing its effect on living organisms with the effect of a standard preparation on the same type of organism. Bioassay and toxicity tests are not the same—see toxicity test. Bioassays often are run on a series of dilutions of whole effluents.

Bioassessment. A general term referring to environmental evaluations involving living organisms; can include bioassays, community analyses, etc.

Bioavailability.⁴ The degree to which a material in environmental media can be assimilated by an organism.

Bioconcentration.⁵ A process by which there is a net accumulation of a chemical directly from an exposure medium into an organism.

Biodegrade.¹⁵ Decompose into more elementary compounds by the action of living organisms, usually referring to microorganisms such as bacteria.

Biomagnification.⁵ Result of the process of bioaccumulation and biotransfer by which tissue concentrations of chemicals in organisms at one trophic level exceed tissue concentrations in organisms at the next lower trophic level in a food chain.

Biomarker.²¹ Biochemical, physiological, and histological changes in organisms that can be used to estimate either exposure to chemicals or the effects of exposure to chemicals.

Biomonitoring.⁵ Use of living organisms as "sensors" in environmental quality surveillance to detect changes in environmental conditions that might threaten living organisms in the environment.

Body Burden. The concentration or total amount of a substance in a living organism; implies accumulation of a substance above background levels in exposed organisms.

Breeding Range. The area utilized by an organism during the reproductive phase of its life cycle and during the time that young are reared.

Bulk Sediment.⁸ Field collected sediments used to conduct toxicity tests; can contain multiple contaminants and/or unknown concentrations of contaminants.

Characterization of Ecological Effects.⁶ A portion of the analysis phase of ecological risk assessment that evaluates the ability of a stressor to cause adverse effects under a particular set of circumstances.

Characterization of Exposure.⁶ A portion of the analysis phase of ecological risk assessment that evaluates the interaction of the stressor with one or more ecological components. Exposure can be expressed as co-occurrence, or contact depending on the stressor and ecological component involved.

Chemicals of Potential Concern.² Chemicals that are potentially site-related and whose data are of sufficient quality for use in a quantitative risk assessment.

Chronic.⁵ Involving a stimulus that is lingering or continues for a long time; often signifies periods from several weeks to years, depending on the reproductive life cycle of the species. Can be used to define either the exposure or the response to an exposure (effect). Chronic exposures typically induce a biological response of relatively slow progress and long duration.

Chronic Response. The response of (or effect on) an organism to a chemical that is not immediately or directly lethal to the organism.

Chronic Tests.⁹ A toxicity test used to study the effects of continuous, long-term exposure of a chemical or other potentially toxic material on an organism.

Community.⁶ An assemblage of populations of different species within a specified location and time.

Complexation.¹⁴ Formation of a group of compounds in which a part of the molecular bonding between compounds is of the coordinate type.

Concentration. The relative amount of a substance in an environmental medium, expressed by relative mass (e.g., mg/kg), volume (ml/L), or number of units (e.g., parts per million).

Concentration-Response Curve.⁵ A curve describing the relationship between exposure concentration and percent of the test population responding.

Conceptual Model.⁶ Describes a series of working hypotheses of how the stressor might affect ecological components. Describes ecosystem or ecosystem components potentially at

risk, and the relationships between measurement and assessment endpoints and exposure scenarios.

Contaminant of (Ecological) Concern. A substance detected at a hazardous waste site that has the potential to affect ecological receptors adversely due to its concentration, distribution, and mode of toxicity.

Control.⁵ A treatment in a toxicity test that duplicates all the conditions of the exposure treatments but contains no test material. The control is used to determine the response rate expected in the test organisms in the absence of the test material.

Coordinate Bond.¹⁴ A chemical bond between two atoms in which a shared pair of electrons forms the bond and the pair of electrons has been supplied by one of the two atoms. Also known as a coordinate valence.

Correlation.¹⁰ An estimate of the degree to which two sets of variables vary together, with no distinction between dependent and independent variables.

Critical Exposure Pathway. An exposure pathway which either provides the highest exposure levels or is the primary pathway of exposure to an identified receptor of concern.

Degradation.¹⁴ Conversion of an organic compound to one containing a smaller number of carbon atoms.

Deposition.¹⁴ The lying, placing, or throwing down of any material.

Depuration.⁵ A process that results in elimination of toxic substances from an organism.

Depuration Rate. The rate at which a substance is depurated from an organism.

Dietary Accumulation.⁹ The net accumulation of a substance by an organism as a result of ingestion in the diet.

Direct Effect (toxin).⁶ An effect where the stressor itself acts directly on the ecological component of interest, not through other components of the ecosystem.

Dose.¹¹ A measure of exposure. Examples include (1) the amount of a chemical ingested, (2) the amount of a chemical absorbed, and (3) the product of ambient exposure concentration and the duration of exposure.

Dose-Response Curve.⁵ Similar to concentration-response curve except that the dose (i.e. the quantity) of the chemical administered to the organism is known. The curve is plotted as Dose versus Response.

Duplicate.⁸ A sample taken from and representative of the same population as another sample. Both samples are carried through the steps of sampling, storage, and analysis in an identical manner.

Ecological Component.⁶ Any part of an ecosystem, including individuals, populations, communities, and the ecosystem itself.

Ecological Risk Assessment.⁶ The process that evaluates the likelihood that adverse ecological effects may occur or are occurring as a result of exposure to one or more stressors.

Ecosystem.⁶ The biotic community and abiotic environment within a specified location and time, including the chemical, physical, and biological relationships among the biotic and abiotic components.

Ecotoxicity.¹¹ The study of toxic effects on nonhuman organisms, populations, or communities.

Estimated or Expected Environmental Concentration.⁵ The concentration of a material estimated as being likely to occur in environmental media to which organisms are exposed.

Exposure.⁶ Co-occurrence of or contact between a stressor and an ecological component. The contact reaction between a chemical and a biological system, or organism.

Exposure Assessment.² The determination or estimation (qualitative or quantitative) of the magnitude, frequency, duration, and route of exposure.

Exposure Pathway.² The course a chemical or physical agent takes from a source to an exposed organism. Each exposure pathway includes a source or release from a source, an exposure point, and an exposure route. If the exposure point differs from the source, transport/exposure media (i.e., air, water) also are included.

Exposure Pathway Model. A model in which potential pathways of exposure are identified for the selected receptor species.

Exposure Point.² A location of potential contact between an organism and a chemical or physical agent.

Exposure Point Concentration. The concentration of a contaminant occurring at an exposure point.

Exposure Profile.⁶ The product of characterizing exposure in the analysis phase of ecological risk assessment. The exposure profile summarizes the magnitude and spatial and temporal patterns of exposure for the scenarios described in the conceptual model.

Exposure Route.² The way a chemical or physical agent comes in contact with an organism (i.e., by ingestion, inhalation, or dermal contact).

Exposure Scenario.⁶ A set of assumptions concerning how an exposure takes place, including assumptions about the exposure setting, stressor characteristics, and activities of an organism that can lead to exposure.

False Negative. The conclusion that an event (e.g., response to a chemical) is negative when it is in fact positive (see Appendix D).

False Positive. The conclusion that an event is positive when it is in fact negative (see Appendix D).

Fate.⁵ Disposition of a material in various environmental compartments (e.g. soil or sediment, water, air, biota) as a result of transport, transformation, and degradation.

Food-Chain Transfer. A process by which substances in the tissues of lower-trophic-level organisms are transferred to the higher-trophic-level organisms that feed on them.

Forage (feeding) Area. The area utilized by an organism for hunting or gathering food.

Habitat.¹ Place where a plant or animal lives, often characterized by a dominant plant form and physical characteristics.

Hazard. The likelihood that a substance will cause an injury or adverse effect under specified conditions.

Hazard Identification.² The process of determining whether exposure to a stressor can cause an increase in the incidence of a particular adverse effect, and whether an adverse effect is likely to occur.

Hazard Index.³ The sum of more than one hazard quotient for multiple substances and/or multiple exposure pathways. The HI is calculated separately for chronic, subchronic, and shorter-duration exposures.

Hazard Quotient.² The ratio of an exposure level to a substance to a toxicity value selected for the risk assessment for that substance (e.g., LOAEL or NOAEL).

Home Range.¹² The area to which an animal confines its activities.

Hydrophilic.²² Denoting the property of attracting or associating with water molecules; characteristic of polar or charged molecules.

Hydrophobic.¹² With regard to a molecule or side group, tending to dissolve readily in organic solvents, but not in water, resisting wetting, not containing polar groups or sub-groups.

Hypothesis.¹² A proposition set forth as an explanation for a specified phenomenon or group of phenomena.

Indirect Effect.⁶ An effect where the stressor acts on supporting components of the ecosystem, which in turn have an effect on the ecological component of interest.

Ingestion Rate. The rate at which an organism consumes food, water, or other materials (e.g., soil, sediment). Ingestion rate usually is expressed in terms of unit of mass or volume per unit of time (e.g., kg/day, L/day).

Ionization.¹⁴ The process by which a neutral atom loses or gains electrons, thereby acquiring a net charge and becoming an ion.

Lethal.⁵ Causing death by direct action.

Lipid.¹³ One of a variety of organic substances that are insoluble in polar solvents, such as water, but that dissolve readily in non-polar organic solvents. Includes fats, oils, waxes, steroids, phospholipids, and carotenes.

Lowest-Observable-Adverse-Effect Level (LOAEL). The lowest level of a stressor evaluated in a toxicity test or biological field survey that has a statistically significant adverse effect on the exposed organisms compared with unexposed organisms in a control or reference site.

Matrix.¹⁴ The substance in which an analyte is embedded or contained; the properties of a matrix depend on its constituents and form.

Measurement Endpoint.⁶ A measurable ecological characteristic that is related to the valued characteristic chosen as the assessment endpoint. Measurement endpoints often are expressed as the statistical or arithmetic summaries of the observations that make up the measurement. As used in this guidance document, measurement endpoints can include measures of effect and measures of exposure, which is a departure from U.S. EPA's (1992a) definition which includes only measures of effect.

Media.¹⁵ Specific environmental compartments—air, water, soil—which are the subject of regulatory concern and activities.

Median Effective Concentration (EC₅₀).⁵ The concentration of a substance to which test organisms are exposed that is estimated to be effective in producing some sublethal response in 50 percent of the test population. The EC₅₀ usually is expressed as a time-dependent value

(e.g., 24-hour EC₅₀). The sublethal response elicited from the test organisms as a result of exposure must be clearly defined.

Median Lethal Concentration (LC₅₀).⁵ A statistically or graphically estimated concentration that is expected to be lethal to 50 percent of a group of organisms under specified conditions.

Metric.¹⁶ Relating to measurement; a type of measurement—for example a measurement of one of various components of community structure (e.g., species richness, % similarity).

Mortality. Death rate or proportion of deaths in a population.

No-Observed-Adverse-Effect Level (NOAEL).⁵ The highest level of a stressor evaluated in a toxicity test or biological field survey that causes no statistically significant difference in effect compared with the controls or a reference site.

Nonparametric.¹⁷ Statistical methods that make no assumptions regarding the distribution of the data.

Parameter.¹⁸ Constants applied to a model that are obtained by theoretical calculation or measurements taken at another time and/or place, and are assumed to be appropriate for the place and time being studied.

Parametric.¹⁴ Statistical methods used when the distribution of the data is known.

Population.⁶ An aggregate of individuals of a species within a specified location in space and time.

Power.¹⁰ The power of a statistical test indicates the probability of rejecting the null hypothesis when it should be rejected (i.e., the null hypothesis is false). Can be considered the sensitivity of a statistical test. (See also Appendix D.)

Precipitation.¹⁴ In analytic chemistry, the process of producing a separable solid phase within a liquid medium.

Precision.¹⁹ A measure of the closeness of agreement among individual measurements.

Reference Site.¹¹ A relatively uncontaminated site used for comparison to contaminated sites in environmental monitoring studies, often incorrectly referred to as a control.

Regression Analysis.¹⁰ Analysis of the functional relationship between two variables; the independent variable is described on the X axis and the dependent variable is described on the Y axis (i.e, the change in Y is a function of a change in X).

Replicate. Duplicate analysis of an individual sample. Replicate analyses are used for quality control.

Representative Samples.¹⁸ Serving as a typical or characteristic sample; should provide analytical results that correspond with actual environmental quality or the condition experienced by the contaminant receptor.

Risk.⁵ The expected frequency or probability of undesirable effects resulting from exposure to known or expected stressors.

Risk Characterization.⁶ A phase of ecological risk assessment that integrates the results of the exposure and ecological effects analyses to evaluate the likelihood of adverse ecological effects associated with exposure to the stressor. The ecological significance of the adverse effects is discussed, including consideration of the types and magnitudes of the effects, their spatial and temporal patterns, and the likelihood of recovery.

Sample.¹⁴ Fraction of a material tested or analyzed; a selection or collection from a larger collection.

Scientific/Management Decision Point (SMDP). A point during the risk assessment process when the risk assessor communicates results of the assessment at that stage to a risk manager. At this point the risk manager determines whether the information is sufficient to arrive at a decision regarding risk management strategies and/or the need for additional information to characterize risk.

Sediment.²⁰ Particulate material lying below water.

Sensitivity. In relation to toxic substances, organisms that are more sensitive exhibit adverse (toxic) effects at lower exposure levels than organisms that are less sensitive.

Sensitive Life Stage. The life stage (i.e., juvenile, adult, etc.) that exhibits the highest degree of sensitivity (i.e., effects are evident at a lower exposure concentration) to a contaminant in toxicity tests.

Species.¹³ A group of organisms that actually or potentially interbreed and are reproductively isolated from all other such groups; a taxonomic grouping of morphologically similar individuals; the category below genus.

Statistic.¹⁰ A computed or estimated statistical quantity such as the mean, the standard deviation, or the correlation coefficient.

Stressor.⁶ Any physical, chemical, or biological entity that can induce an adverse response.

Sublethal.⁵ Below the concentration that directly causes death. Exposure to sublethal concentrations of a substance can produce less obvious effects on behavior, biochemical and/or physiological functions, and the structure of cells and tissues in organisms.

Threshold Concentration.⁵ A concentration above which some effect (or response) will be produced and below which it will not.

Toxic Mechanism of Action.²³ The mechanism by which chemicals produce their toxic effects, i.e., the mechanism by which a chemical alters normal cellular biochemistry and physiology. Mechanisms can include; interference with normal receptor-ligand interactions, interference with membrane functions, interference with cellular energy production, and binding to biomolecules.

Toxicity Assessment. Review of literature, results in toxicity tests, and data from field surveys regarding the toxicity of any given material to an appropriate receptor.

Toxicity Test.⁵ The means by which the toxicity of a chemical or other test material is determined. A toxicity test is used to measure the degree of response produced by exposure to a specific level of stimulus (or concentration of chemical) compared with an unexposed control.

Toxicity Value.² A numerical expression of a substance's exposure-response relationship that is used in risk assessments.

Toxicant. A poisonous substance.

Trophic Level.⁶ A functional classification of taxa within a community that is based on feeding relationships (e.g., aquatic and terrestrial plants make up the first trophic level, and herbivores make up the second).

Type I Error.¹⁰ Rejection of a true null hypothesis (see also Appendix D).

Type II Error.¹⁰ Acceptance of a false null hypothesis (see also Appendix D).

Uptake.⁵ A process by which materials are transferred into or onto an organism.

Uncertainty.¹¹ Imperfect knowledge concerning the present or future state of the system under consideration; a component of risk resulting from imperfect knowledge of the degree of hazard or of its spatial and temporal distribution.

Volatilization.¹⁴ The conversion of a chemical substance from a liquid or solid state to a gaseous vapor state.

Xenobiotic.⁶ A chemical or other stressor that does not occur naturally in the environment. Xenobiotics occur as a result of anthropogenic activities such as the application of pesticides and the discharge of industrial chemicals to air, land, or water.

ENDNOTES

¹ Krebs 1978, ² U.S. EPA 1989, ³ Calow 1993, ⁴ Freedman 1989, ⁵ Rand and Petrocelli 1985, ⁶ U.S. EPA 1992a, ⁷ Ricklefs 1990, ⁸ U.S. EPA 1992b, ⁹ ASTM 1993a, ¹⁰ Sokal and Rohlf 1981, ¹¹ Suter 1993, ¹² Wallace et al. 1981, ¹³ Curtis 1983, ¹⁴ Parker 1994, ¹⁵ Sullivan 1993, ¹⁶ U.S. EPA 1990, ¹⁷ Zar 1984, ¹⁸ Keith 1988, ¹⁹ Gilbert 1987, ²⁰ ASTM 1993b, ²¹ Huggett et al. 1992, ²² Stedman 1995, ²³ Amdur et al. 1991.

GLOSSARY REFERENCES

- Amdur, M.O.; Doull J.; Klaassen, C.D. 1991. *Casarett and Doull's Toxicology. Fourth Edition*. New York, NY: McGraw-Hill.
- American Society for Testing and Materials (ASTM). 1993a. ASTM Standard E 943. Standard terminology relating to biological effects and environmental fate.
- American Society for Testing and Materials (ASTM). 1993b. ASTM Standard E 1525. Standard guide for designing biological tests with sediments.
- Calow, P. (ed.). 1993. *Handbook of Ecotoxicology. Volume 1*. Boston, MA: Blackwell Publishing.
- Curtis, H. 1983. *Biology. Fourth Edition*. New York, NY: Worth.
- Freedman, B. 1989. *Environmental Ecology. The Impacts of Pollution and Other Stresses on Ecosystem Structure and Function*. New York, NY: Academic Press.
- Gilbert, R.O. 1987. *Statistical Methods for Environmental Pollution Monitoring*. New York, NY: Reinhold.
- Keith, L.H. (ed.). 1988. *Principles of Environmental Sampling*. American Chemical Society.
- Krebs, C.J. 1978. *Ecology: The experimental analysis of distribution and abundance*. Second edition. New York, NY: Harper & Row.
- Huggett, R.J.; Kimerle, R.A.; Nehrlé, P.M. Jr.; Bergman, H.L. (eds.). 1992. *Biomarkers: Biochemical, Physiological, and Histological Markers of Anthropogenic Stress*. A Special Publication of SETAC. Chelsea, MI: Lewis Publishers.

- Parker, S.P. (ed.). 1994. *Dictionary of Scientific and Technical Terms*. Fifth Edition. New York, NY: McGraw-Hill.
- Rand, G.M.; Petrocelli, S.R. 1985. *Fundamentals of Aquatic Toxicology. Methods and Applications*. New York, NY: McGraw Hill.
- Ricklefs, R.E. 1990. *Ecology. Second Edition*. New York, NY: W.H. Freeman.
- Sokal, R.R.; Rohlf, F.J. 1981. *Biometry. Second Edition*. New York, NY: W.H. Freeman.
- Stedman, T.L. 1995. *Stedman's Medical Dictionary. 26th Edition*. Baltimore, MD: Williams and Wilkins.
- Sullivan, T.F.P. 1993. *Environmental Regulatory Glossary*. Government Institutes, Inc.
- Suter, G.W. II. 1993. *Ecological Risk Assessment*. Ann Arbor, MI: Lewis.
- U. S. Environmental Protection Agency (U.S. EPA). 1989. *Risk Assessment Guidance for Superfund: Volume 1 - Human Health*. Washington, DC: Office of Emergency and Remedial Response; EPA/540/1-89/002.
- U. S. Environmental Protection Agency (U.S. EPA). 1990. *Macroinvertebrate Field and Laboratory Methods for Evaluating the Biological Integrity of Surface Waters*. Washington, DC: Office of Water; EPA/600/4-90/030.
- U. S. Environmental Protection Agency (U.S. EPA). 1992a. *Framework for Ecological Risk Assessment*. Washington, DC: Risk Assessment Forum; EPA/630/R-02/011.
- U.S. Environmental Protection Agency (U.S. EPA). 1992b. *Sediment Classification Methods Compendium*. Washington, DC: Office of Water; EPA/823/R-092/006.
- Wallace, R.A.; King, J.L.; Sanders, G.P. 1981. *Biology. The Science of Life. Second Edition*. IL: Scott, Foresman & Co.
- Zar, J.H. 1984. *Biostatistical Analysis*. Princeton, NJ: Prentice-Hall.

APPENDIX A

EXAMPLE ECOLOGICAL RISK ASSESSMENTS FOR HYPOTHETICAL SITES

INTRODUCTION

Appendix A provides examples of Steps 1 through 5 of the ecological risk assessment process for three hypothetical sites:

- (1) A former municipal landfill from which copper is leaching into a large pond down-gradient of the site (the copper site);
- (2) A former chemical production facility that spilled DDT, which has been transported into a nearby stream by surface water runoff (the DDT site); and
- (3) A former waste-oil recycling facility that disposed of PCBs in a lagoon from which extensive soil contamination has resulted (the PCB site).

These examples are intended to illustrate key points in Steps 1 through 5 of the ecological risk assessment process. No actual site is the basis for the examples.

The examples stop with Step 5 because the remaining steps (6 through 8) of the ecological risk assessment process and the risk management decisions depend on site-specific data collected during a site investigation. We have not attempted to develop hypothetical data for analysis or the full range of information that a site risk manager would consider when evaluating remedial options.

EXAMPLE 1: COPPER SITE

STEP 1: SCREENING-LEVEL PROBLEM FORMULATION AND ECOLOGICAL EFFECTS EVALUATION

Site history. This is a former municipal landfill located in an upland area of the mid-Atlantic plain. Residential, commercial, and industrial refuse was disposed of at this site in the 1960s and 1970s. Large amounts of copper wire also were disposed at this site over several years. Currently, minimal cover has been placed over the fill and planted with grasses. Terrestrial ecosystems in the vicinity of the landfill include upland forest and successional fields. Nearby land uses include agriculture and residential and commercial uses. The landfill cover has deteriorated in several locations. Leachate seeps have been noted on the slope of the landfill, and several seeps discharge to a five-acre pond down-gradient of the site.

Site visit. A preliminary site visit was conducted and the ecological checklist was completed. The checklist indicated that the pond has an organic substrate; emergent vegetation, including cattail and rushes, occurs along the shore near the leachate seeps; and the pond reaches a depth of five feet toward the middle. Fathead minnows, carp, and several species of sunfish were observed, and the benthic macroinvertebrate community appeared to be diverse. The pond water was clear, indicating an absence of phytoplankton. The pond appears to function as a valuable habitat for fish and other wildlife using this area. Preliminary sampling indicated elevated copper levels in the seep as well as elevated base cations, total organic carbon (TOC), and depressed pH levels (pH 5.7).

Problem formulation. Copper is leaching from the landfill into the pond from a seep area. EPA's ambient water quality criteria document for copper (U.S. EPA, 1985) indicates that it can cause toxic effects in aquatic plants, aquatic invertebrates, and young fish at relatively low water concentrations. Thus, the seep might threaten the ability of the pond to support macroinvertebrate and fish communities and the wildlife that feed on them. Terrestrial ecosystems do not need to be evaluated because the overland flow of the seeps is limited to short gullies, a few inches wide. Thus, the area of concern has been identified as the five-acre pond and the associated leachate seeps. Copper in surface water and sediments of the pond might be of ecological concern.

Ecological effects evaluation. Copper is toxic to both aquatic plants and aquatic animals. Therefore, aquatic toxicity-based data will be used to screen for ecological risk in the preliminary risk calculation. The screening ecotoxicity value selected for water-column exposure is the U.S. EPA chronic ambient water quality criterion (12 µg/L at a water hardness of 100 mg/L as CaCO₃). A screening ecotoxicity value for copper in sediments was identified as 34 mg/kg (U.S. EPA, 1996).

STEP 2: SCREENING-LEVEL EXPOSURE ESTIMATE AND RISK CALCULATION

Exposure estimate. Preliminary sampling data indicate that the leachate contains 53 µg/L copper as well as elevated base cations, elevated TOC, and depressed pH (pH 5.7). Sediment concentrations range from 300 mg/kg to below detection (2 mg/kg), decreasing with distance from the leachate seeps.

Risk calculation. The copper concentration in the seep water (53 µg/L) exceeds the chronic water quality criterion for copper (12 µg/L). The maximum sediment copper concentration of 300 mg/kg exceeds the screening ecotoxicity value for copper in sediments (34 mg/kg). Therefore, the screening-level hazard quotients for both sediment and water exceed one. The decision at the Scientific/Management Decision Point (SMDP) is to continue the ecological risk assessment.

Similar screening for the levels of base cations generated hazard quotients below one in the seep water. Although TOC and pH are not regulated under CERCLA, the possibility that those parameters might affect the biota of the pond should be kept in mind if surveys of the pond biota are conducted. Sediment concentrations of chemicals other than copper generated hazard quotients (HQs) of less than one at the maximum concentrations found.

STEP 3: BASELINE RISK ASSESSMENT PROBLEM FORMULATION

Based on the screening-level risk assessment, copper is known to be the only contaminant of ecological concern at the site.

Ecotoxicity literature review. A review of the literature on the ecotoxicity of copper to aquatic biota was conducted and revealed several types of information. Young aquatic organisms are more sensitive to copper than adults (Demayo et al., 1982; Kaplan and Yoh, 1961; Hubschman, 1965). Fish larvae usually are more sensitive than embryos (McKim et al., 1978; Weis and Weis, 1991), and fish become less sensitive to copper as body weight increases (Demayo et al., 1982). Although the exact mechanism of toxicity to fish is unknown, a loss of osmotic control has been noted in some studies (Demayo et al. 1982; Cheng and Sullivan, 1977).

Flowthrough toxicity studies in which copper concentrations were measured revealed LC₅₀ values ranging from 75 to 790 µg/L for fathead minnows and 63 to 800 µg/L for common carp (U.S. EPA, 1985). Coldwater fish species, such as rainbow trout, can be more sensitive, and species like pumpkinseeds (a sunfish) and bluegills are less sensitive (U.S. EPA, 1985). Although fish fry usually are the most sensitive life stage, this is not always the case; Pickering et al. (1977) determined an LC₅₀ of 460 µg/L to 6-month-old juveniles and an LC₅₀ of 490 µg/L to 6-week-old fry for fathead minnows. A copper concentration in water of 37 µg/l has been shown to cause a significant reduction in fish egg production (Pickering et al., 1977).

Elevated levels of copper in sediments have been associated with changes in benthic community structure, notably reduced numbers of species (Winner et al., 1975; Kraft and Sypniewski, 1981). Studies also have been conducted with adult *Hyaella azteca* (an amphipod) exposed to copper in sediments. One of these studies indicated an LC₅₀ of 1,078 mg/kg in the sediment (Cairns et al., 1984); however, a no-observed-adverse-effect level (NOAEL) for copper in sediments was not identified for an early life stage of a benthic invertebrate.

A literature review of the ecotoxicity of copper to aquatic plants, both algae and vascular plants, did not reveal information on the toxic mechanism by which copper affects plants. The review did indicate that exposure of plants to high copper levels inhibits photosynthesis and growth (U.S. EPA, 1985), and cell separation after cell division (Hatch, 1978). Several studies conducted using *Selenastrum capricornutum* indicated that concentrations at 300 µg/L kill algae after 7 days, and a value of 90 µg/l causes complete growth inhibition after 7 days (Bartlett et al., 1974).

The literature indicates that copper does not biomagnify in food chains and does not bioaccumulate in most animals because it is a biologically regulated essential element. Accumulation in phytoplankton and filter-feeding mollusks, however, does occur. The toxicity of copper in water is influenced by water hardness, alkalinity, and pH (U.S. EPA, 1985).

Exposure pathways. A flow diagram was developed to depict the environmental pathways that could result in impacts of copper to the pond's biota (see Exhibit A-1). Direct exposure to copper in the pond water and sediments could cause acute or chronic toxicity in early life stages of fish and/or benthic invertebrates, and in aquatic plants. Risks to filter-feeding mollusks and phytoplankton as well as animals that feed on them are not considered because the mollusks and phytoplankton are unlikely to occur in significant quantities in the pond. The exposure pathways that will be evaluated, therefore, are direct contact with contaminated sediments and water.

Assessment endpoints and conceptual model. Based on the screening-level risk assessment, the ecotoxicity literature review, and the complete exposure pathways, development of a conceptual model for the site is initiated. Copper can be acutely or chronically toxic to organisms in an aquatic community through direct exposure of the organisms to copper in the water and sediments. Threats of copper to higher trophic level organisms are unlikely to exceed threats to organisms at the base of the food chain, because copper is an essential nutrient which is effectively regulated by most organisms if the exposure is below toxic levels. Fish fry in particular can be very sensitive to copper in water.

Based on these receptors and the potential for both acute and chronic toxicity, an appropriate general assessment endpoint for the ecosystem would be the maintenance of the community composition of the pond. A more operational definition of the assessment endpoint would be the maintenance of pond community structure typical for the locality and

for the physical attributes of the pond, with no loss of species or community alteration due to copper toxicity.

Risk questions. One question is whether the concentrations of copper present in the sediments and water over at least part of the pond are toxic to aquatic plants or animals. A further question is what concentration of copper in sediments represents a threshold for adverse effects. That level could be used as a preliminary cleanup goal.

STEP 4: MEASUREMENT ENDPOINTS AND STUDY DESIGN

To answer the hypothesis identified in Step 3, three lines of evidence were considered when selecting measurement endpoints: (1) whether the ambient copper levels are higher than levels known to be directly toxic to aquatic organisms likely or known to be present in the pond; (2) whether water and sediments taken from the pond are more toxic to aquatic organisms than water and sediments from a reference pond; and (3) whether the aquatic community structure in the site pond is simplified relative to a reference pond.

Measurement endpoints. Since the identified assessment endpoint is maintaining a typical pond community structure, the possibility of directly measuring the condition of the plant, fish, and macroinvertebrate communities in the pond was considered. Consultation with experts on benthic macroinvertebrates suggested that standard measures of the pond benthic invertebrate community probably would be insensitive measures of existing effects at this particular site because of the high spatial variation in benthic communities within and among ponds of this size. Measuring the fish community also would be unsuitable, due to the limited size of the pond and low diversity of fish species anticipated. Since copper is not expected to bioaccumulate or biomagnify in this pond, direct toxicity testing was selected as appropriate. Because early life stages tend to be more sensitive to the toxic effects of copper than older life stages, chronic toxicity would be measured on early life stages. For animals, toxicity is defined as a statistically significant decrease in survival or juvenile growth rates (measurement endpoints) of a test group exposed to water or sediments from the site compared with a test group exposed to water or sediments from a reference site. For plants, toxicity is defined as a statistically significant decrease in growth rate (measurement endpoint) with the same comparison.

One toxicity test selected is a 10-day (i.e., chronic) solid-phase sediment toxicity test using an early life stage of *Hyalella azteca*. The measures of effects for the test are mortality rates and growth rates (measured as length and weight increases). Two water-column toxicity tests will be used: (1) a 7-day test using the alga *Selenastrum capricornutum* (growth test) and (2) a 7-day larval fish test using *Pimephales promelas* (mortality and growth endpoints). The *H. azteca* and *P. promelas* toxicity tests will be used to determine the effects of copper on early life stages of invertebrates and fish in sediment and the water column, respectively. The test on *S. capricornutum* will be used to determine the phytotoxicity of copper in the water column.

EXHIBIT A-1
Conceptual Model for the Copper Site

A-5

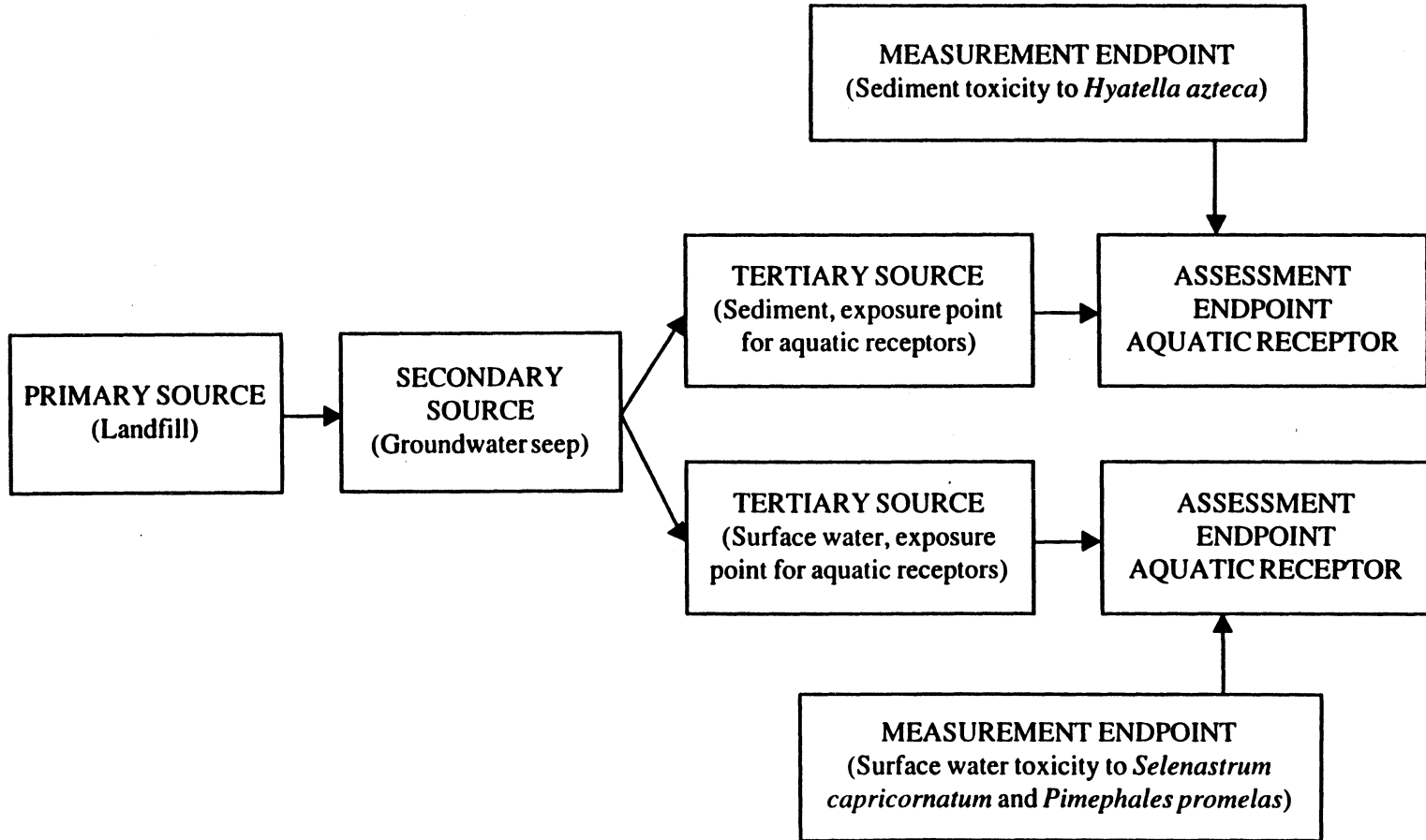

Study design. To answer the questions stated in the problem formulation step, the study design specified in the following. The water column tests will be run on 100 percent seep water, 100 percent pond water near the seep, 100 percent reference-site water, and the laboratory control. U.S. EPA test protocols will be followed. Five sediment samples will be collected from the pond bottom at intervals along the observed concentration gradient, from a copper concentration of 300 mg/kg at the leachate seeps down to approximately 5 mg/kg near the other end of the pond. The sediment sampling locations will transect the pond at equidistant locations and include the point of maximum pond depth. All sediment samples will be split so that copper concentrations can be measured in sediments from each sampling location. A reference sediment will be collected and a laboratory control will be run. Test organisms will not be fed during the test; sediments will be sieved to remove native organisms and debris. Laboratory procedures will follow established protocols and will be documented and reviewed prior to initiation of the test. For the water-column test, statistical comparisons will be made between responses to each of the two pond samples and the reference site, as well as the laboratory control. Statistical comparisons also will be made of responses to sediments taken from each sampling location and responses to the reference sediment sample.

Because leachate seeps can be intermittent (depending on rainfall), the study design specifies that a pre-sampling visit is required to confirm that the seep is flowing and can be sampled. The study design also specifies that both sediments and water will be sampled at the same time at each sampling location.

As the work plan (WP) and sampling and analysis plan (SAP) were finished, the ecological risk assessor and the risk manager agreed on the site conceptual model, assessment endpoints, and study design (SMDP).

STEP 5: FIELD VERIFICATION OF STUDY DESIGN

A site assessment was conducted two days prior to the scheduled initiation of the site investigation to confirm that the seep was active. It was determined that the seep was active and that the site investigation could be initiated.

REFERENCES

- Bartlett, L.; Rabe, F.W.; Funk, W.H. 1974. Effects of copper, zinc, and cadmium on *Selenastrum capricornutum*. *Water Res.* 8: 179-185.
- Cairns, M.A.; Nebeker, A.V.; Gakstatter, J.H.; Griffis, W.L. 1984. Toxicity of copper-spiked sediments to freshwater invertebrates. *Environ. Toxicol. Chem.* 3: 345-445.
- Cheng, T.C.; Sullivan, J.T. 1977. Alterations in the osmoregulation of the pulmonate gastropod *Biomphalaria glabrata* due to copper. *J. Invert. Path.* 28: 101.

- Demayo, A., et al. 1982. Effects of copper on humans, laboratory and farm animals, terrestrial plants, and aquatic life. *CRC Crit. Rev. Environ. Control.* 12: 183.
- Hatch, R.C. 1978. Poisons causing respiratory insufficiency. In: L.M. Jones, N.H. Booth and L.E. McDonald (eds.), *Veterinary Pharmacology and Therapeutics*. Iowa State University, IA: Ames Press.
- Hubschman, J.H. 1965. Effects of copper on the crayfish *Orconectes rusticus* (Girard). I. Acute toxicity. *Crustaceana* 12: 33-42.
- Kaplan, H.M.; Yoh, L. 1961. Toxicity of copper to frogs. *Herpetologia* 17: 131-135.
- Kraft, K.J.; Sypniewski, R.H. 1981. Effect of sediment copper on the distribution of benthic macroinvertebrates in the Keweenaw Waterway. *J. Great Lakes Res.* 7: 258-263.
- McKim, J.M.; Eaton, J.G.; Holcombe, G.W. 1978. Metal toxicity to embryos and larvae of eight species of freshwater fish. II. Copper. *Bull. Environ. Contam. Toxicol.* 19: 608-616.
- Pickering, Q.; Brungs, W.; Gast, M. 1977. Effect of exposure time and copper concentration of fathead minnows, *Pimephales promelas* (Rafinesque). *Aquatic Toxicol.* 12: 107.
- U.S. Environmental Protection Agency (U.S. EPA). 1996. *Ecotox Thresholds. ECO Update, Intermittent Bulletin, Volume 3, Number 2*. Washington, DC: Office of Emergency and Remedial Response, Hazardous Site Evaluation Division; Publication 9345.0-12FSI; EPA/540/F-95/038; NTIS PB95-963324.
- U.S. Environmental Protection Agency (U.S. EPA). 1985. *Ambient Water Quality Criteria for Copper*. Washington, DC: Office of Water; EPA/440/5-84/031.
- Weis, P.; Weis, J.S. 1991. The developmental toxicity of metals and metalloids in fish. In: Newman, M.C.; McIntosh, A.W. (eds.), *Metal Ecotoxicology: Concepts and Applications*. Boca Raton, FL: CRC Press, Inc., Lewis Publishers.
- Winner, R.W.; Kelling, T.; Yeager, R.; et al. 1975. Response of a macroinvertebrate fauna to a copper gradient in an experimentally-polluted stream. *Verh. Int. Ver. Limnol.* 19: 2121-2127.

EXAMPLE 2: DDT SITE

STEP 1: SCREENING-LEVEL PROBLEM FORMULATION AND ECOLOGICAL EFFECTS EVALUATION

Site history. This is the site of a former chemical production facility located adjacent to a stream. The facility manufactured and packaged dichlorodiphenyltrichloroethane (DDT). Due to poor storage practices, several DDT spills have occurred.

Site visit. A preliminary site visit was conducted and the ecological checklist was completed. Information gathered indicates that surface water drainage from the site flows through several drainage swales toward an unnamed creek. This creek is a second-order stream containing riffle-run areas and small pools. The stream substrate is composed of sand and gravel in the pools with some depositional areas in the backwaters and primarily cobble in the riffles.

Problem formulation. Previous sampling efforts indicated the presence of DDT and its metabolites in the stream's sediments over several miles at concentrations up to 230 mg/kg. A variety of wildlife, especially piscivorous birds, use this area for feeding. Many species of minnow have been noted in this stream. DDT is well known for its tendency to bioaccumulate and biomagnify in food chains, and available evidence indicates that it can cause reproductive failure in birds due to eggshell thinning.

The risk assessment team and risk manager agreed that the assessment endpoint is adverse effects on reproduction of high-trophic-level wildlife, particularly piscivorous birds.

Ecological effects evaluation. Because DDT is well studied, a dietary concentration above which eggshell thinning might occur was identified in existing U.S. EPA documents on the ecotoxicity of DDT. Moreover, a no-observed-adverse-effect-level (NOAEL) for the ingestion route for birds also was identified.

STEP 2: SCREENING-LEVEL EXPOSURE ESTIMATE AND RISK CALCULATION

Exposure estimate. For the screening-level exposure estimate, maximum concentrations of DDT identified in the sediments were used. To estimate the concentration of DDT in forage fish, the maximum concentration in sediments was multiplied by the highest DDT bioaccumulation factor relating forage fish tissue concentrations to sediment concentrations reported in the literature. Moreover, it was assumed that the piscivorous birds obtain 100 percent of their diet from the contaminated area.

Risk calculation. The predicted concentrations of DDT in forage fish were compared with the dietary NOAEL for DDT in birds. This risk screen indicated that DDT concentrations measured at this site might be high enough to cause adverse reproductive

effects in birds. Thus, transfer of DDT from the sediments to the stream and biota are of concern at this site.

STEP 3: BASELINE RISK ASSESSMENT PROBLEM FORMULATION

Based on the screening-level risk assessment, potential bioaccumulation of DDT in aquatic food chains and effects of DDT on reproduction in piscivorous birds are known concerns. During refinement of the problem, the potential for additional ecological effects of DDT was examined.

Ecotoxicity literature review. In freshwater systems, DDT can have direct effects on animals, particularly aquatic insects. A literature review of the aquatic toxicity of DDT was conducted, and a NOAEL and LOAEL identified for the toxicity of DDT to aquatic insects. Aquatic plants are not affected by DDT. Additional quantitative information on effects of DDT on birds was reviewed, particularly to identify what level of eggshell thinning is likely to reduce reproductive success. A number of studies have correlated DDT residues measured in eggs of birds to increased eggshell thinning and egg loss due to breakage. Eggshell thinning of more than 20 percent appears to result in decreased hatching success due to eggshell breakage (Anderson and Hickey, 1972; Dilworth et al., 1972). Information was not available for any piscivorous species of bird. Lincer (1975) conducted a laboratory feeding study using American kestrels. Females fed a diet of 6 mg/kg DDE¹ (1.1 mg/kgBW-day) produced eggs with shells which were 25.5 percent thinner than archived eggshells collected prior to widespread use of DDT. Based on this information, a LOAEL of 1.1 mg/kgBW-day was selected to evaluate the effects of DDT on piscivorous birds.

Exposure pathways, assessment endpoints, and conceptual model. Based on knowledge of the fate and transport of DDT in aquatic systems and the ecotoxicity of DDT to aquatic organisms and birds, a conceptual model was initiated. DDT buried in the sediments can be released to the water column during resuspension and redistribution of the sediments. Some diffusion of DDT to the water column from the sediment surface also will occur. The benthic community would be an initial receptor for the DDT in sediments, which could result in reduced benthic species abundance and DDT accumulation in species that remain. Fish that feed on benthic organisms might be exposed to DDT both in the water column and in their food. Piscivorous birds would be exposed to the DDT that has accumulated in the fish, and could be exposed at levels sufficiently high to cause more than 20 percent eggshell thinning. Based on this information, two assessment endpoints were identified: (1) maintaining stream community structure typical for the stream order and location, and (2) protecting piscivorous birds from eggshell thinning that could result in reduced reproductive success.

¹ DDE is a degradation product of DDT; typically, field measures of DDT are reported as the sum of the concentrations of DDT, DDE, and DDD (another degradation product).

A flow diagram of the exposure pathways for DDT was added to the conceptual model (Exhibit A-2). The diagram identifies the primary, secondary, and tertiary sources of DDT at the site, as well as the primary, secondary, and tertiary types of receptors that could be exposed.

Risk questions. Two questions were developed: (1) has the stream community been affected by the DDT, and (2) have food-chain accumulation and transfer of DDT occurred to the extent that 20 percent or more eggshell thinning would be expected in piscivorous birds that use the area.

STEP 4: MEASUREMENT ENDPOINTS AND STUDY DESIGN

Measurement endpoints. For the assessment endpoint of protecting piscivorous birds from eggshell thinning, the conceptual model indicated that DDT in sediments could reach piscivorous birds through forage fish. Belted kingfishers are known to feed in the stream. They also have the smallest home range of the piscivorous birds in the area, which means that more kingfishers can forage entirely from the contaminated stream area than can other species of piscivorous birds. Thus, one can conclude that, if the risk assessment shows no threat of eggshell thinning to the kingfisher, there should be minimal or no threat to other piscivorous birds that might utilize the site. Eggshell thinning in the belted kingfisher therefore was selected as the measure of effect.

Data from the literature suggest that DDT can have a bioaccumulation factor in surface water systems as high as six orders of magnitude (10^6); however, in most aquatic ecosystems, the actual bioaccumulation of DDT from the environment is lower, often substantially lower. Many factors influence the actual accumulation of DDT in the environment. There is considerable debate over the parameters of any proposed theoretical bioaccumulation model; therefore, it was decided to measure tissue residue levels in the forage fish at the site instead of estimating the tissue residue levels in forage fish using a bioaccumulation factor (BAF).

Existing information on the distribution of DDT in the stream indicates that a general gradient of DDT concentrations exists in the sediments, and five locations could be identified that corresponded to a range of DDT concentrations in sediments. Based on information available on fish communities in streams similar to the one in the site area, creek chub (*Semotilus atromaculatus*) were selected to measure exposure levels for kingfishers. Creek chub feed on benthic invertebrates, which are in direct contact with the contaminated sediments. Adult creek chub average 10 inches and about 20 grams, allowing for analysis of individual fish. Creek chub also have small home ranges during the spring and summer, and thus it should be possible to relate DDT levels in the chub to DDT levels in the sediments.

EXHIBIT A-2
Conceptual Model for the Stream DDT Site

A-11

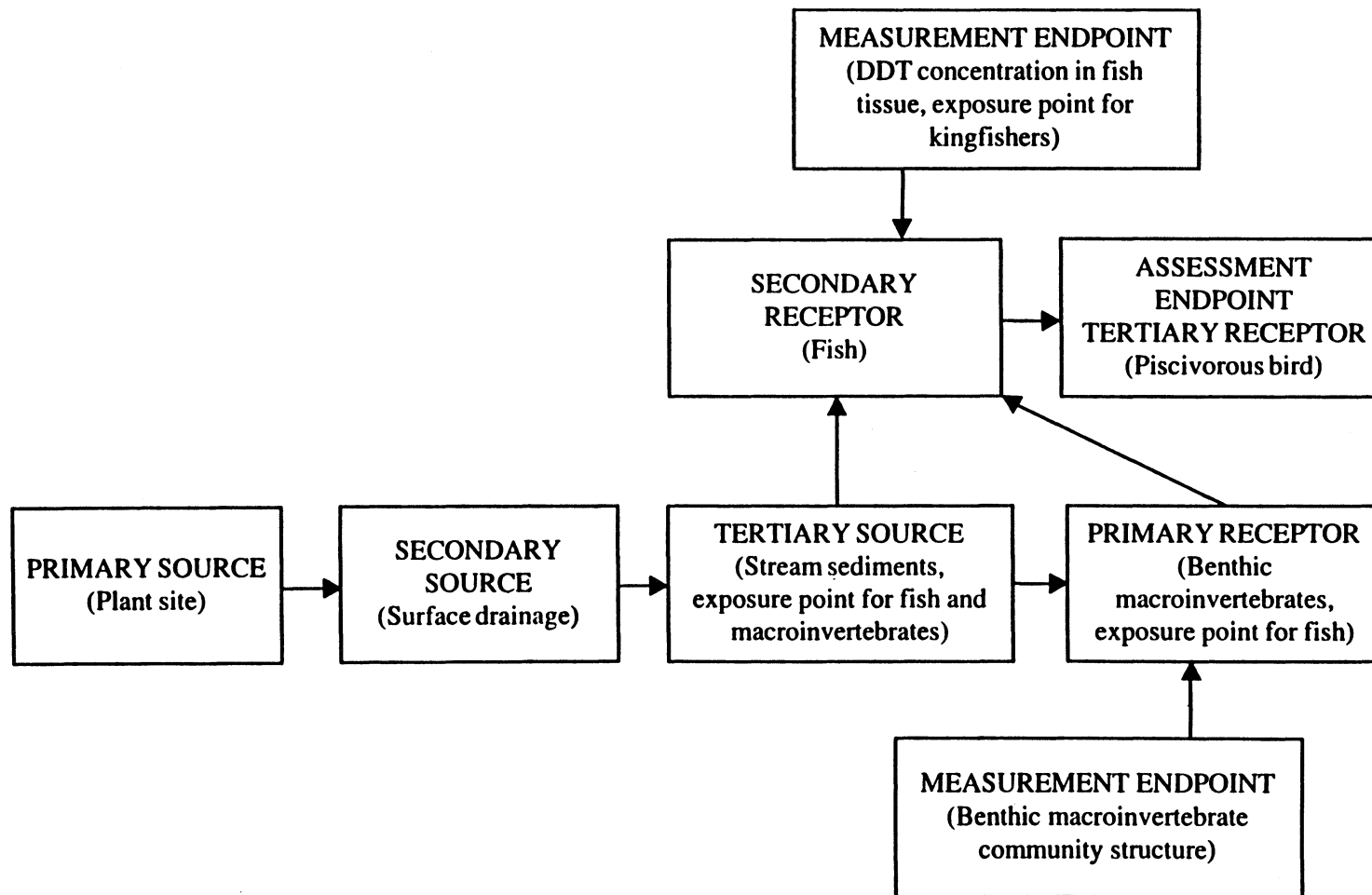

For the assessment endpoint of maintaining stream community structure, the selected measurement endpoints were several metrics describing the abundance and trophic structure of the stream benthic macroinvertebrate community.

Study design. The study design specified that creek chub would be collected at several locations with known DDT concentrations in sediments. The fish would be analyzed for body burdens of DDT, and the relationship between DDT levels in the sediments and in the creek chub would be established. The fish DDT concentrations would be used to evaluate the DDT threat to piscivorous birds feeding on the fish at each location. Using the DDT concentrations measured in fish that correspond to a LOAEL and NOAEL for adverse effects in birds, the corresponding sediment contamination levels would be determined. Those sediment DDT levels then could be used to derive a cleanup level that would reduce threats of eggshell thinning to piscivorous birds.

The study design for measuring DDT residue levels in creek chub specified that 10 creek chub of the same size and sex would be collected at each location and that each creek chub be at least 20 grams, so that individuals could be analyzed. In addition, at one location, QA/QC requirements dictated that an additional 10 fish be collected. In this example, it was necessary to verify in the field that sufficient numbers of creek chub of the specified size were present to meet the tissue sampling requirements. In addition, the stream conditions needed to be evaluated to determine what fish sampling techniques would work best at the targeted locations.

The study design and methods for benthic macroinvertebrate collection followed the Rapid Bioassessment Protocol (RBP) manual for level three evaluation (U.S. EPA, 1989). Benthic macroinvertebrate samples were co-located with sampling for fish tissue residue levels so that one set of co-located water and sediment samples for analytic chemistry could serve for comparison with both tissue analyses.

The study design also specified that the hazard quotient (HQ) method would be used to evaluate the effects of DDT on the kingfisher during risk characterization. To determine the HQ, the estimated daily dose of DDT consumed by the kingfishers is divided by a LOAEL of 1.1 mg/kgBW-day for kestrels. To estimate the DDT dose to the kingfisher, the DDT concentrations in the chub is multiplied by the fish ingestion rate for kingfishers and divided by the body weight of kingfishers. This dose is adjusted by the area use factor. The area use factor corresponds to the proportion of the diet of a kingfisher that would consist of fish from the contaminated area. The area use factor is a function of the home range size of kingfishers relative to the area of contamination. The adjusted dose is compared to the LOAEL. A HQ of greater than one implies that impaired reproductive success in kingfishers due to site contamination is likely, and an HQ of less than one implies impacts due to site contaminants are unlikely (see text Section 2.3 for a description of HQs).

STEP 5: FIELD VERIFICATION OF STUDY DESIGN

A field assessment was conducted and several small fish collection techniques were used to determine which technique was the most effective for capturing creek chub at the site. Collected chub were examined to determine the size range available and to determine if individuals could be sexed.

Seine netting the areas targeted indicated that the creek chub might not be present in sufficient numbers to provide the necessary biomass for chemical analyses. Based on these findings, a contingency plan was agreed to (SMDP), which stated that both the creek chub and the longnosed dace (*Rhinichthys cataractae*) would be collected. If the creek chub were collected at all locations in sufficient numbers, those samples would be analyzed and the dace would be released. If sufficient creek chub could not be collected but sufficient longnosed dace could, the longnosed dace would be analyzed and the creek chub released. If neither species could be collected at all locations in sufficient numbers, then a mix of the two species would be used; however, for any given site only one species would be analyzed. In addition, at one location, preferably one with high DDT levels in the sediment, sufficient numbers of approximately 20 gram individuals of both species would be collected to allow comparison (and calibration) of the accumulation between the two species. If necessary to meet the analytic chemistry needs, similarly-sized individuals of both sexes of creek chub would be pooled. Pooling two or more individuals would be necessary for the smaller dace. The risk assessment team decided that the fish samples would be collected by electro-shocking. Field notes for all samples would document the number of fish per sample pool, sex, weight, length, presence of parasites or deformities, and other measures and might help to explain any anomalous data.

REFERENCES

- Anderson, D.W.; Hickey, J.J. 1972. Eggshell changes in certain North American birds. In: Voos, K.H. (ed.), *Proceedings: XV International Ornithological Congress*. The Hague, Netherlands; pp. 514-540.
- Dilworth, T.G., Keith, J.A.; Pearce, P.A.; Reynolds, L.M. 1972. DDE and eggshell thickness in New Brunswick woodcock. *J. Wildl. Manage.* 36: 1186-1193.
- Lincer, J.L. 1975. DDE-induced eggshell thinning in the American kestrel; a comparison of the field situation and laboratory results. *J. App. Ecol.* 12: 781-793.
- U.S. Environmental Protection Agency (U.S. EPA). 1989. *Rapid Bioassessment Protocols for Use in Streams and Rivers: Benthic Macroinvertebrates and Fish*. Washington, DC: Office of Water (Plafkin, J.L., Barbour, M.T., Porter, K.D., Gross, S.K., and Hughes, R.M., authors); EPA/440/4-89/001.

EXAMPLE 3: PCB SITE

STEP 1: SCREENING-LEVEL PROBLEM FORMULATION AND ECOLOGICAL EFFECTS EVALUATION

Site history. This is a former waste-oil recycling facility located in a remote area. Oils contaminated with polychlorinated biphenyl compounds (PCBs) were disposed of in a lagoon. The lagoon was not lined, and the soil is composed mostly of sand. Oils contaminated with PCBs migrated through the soil and contaminated a wide area adjacent to the site.

Site visit. During the preliminary site visit, the ecological checklist was completed. Most of the habitat is upland forest, old field, and successional terrestrial areas. Biological surveys at this site have noted a variety of small mammal signs. In addition, red-tailed hawks were observed.

Problem formulation. At least 10 acres surrounding the site are known to be contaminated with PCBs. Some PCBs are reproductive toxins in mammals (Ringer et al., 1972; Aulerich et al., 1985; Wren, 1991; Kamrin and Ringer, 1996). When ingested, they induce (i.e., increase concentrations and activity of) enzymes in the liver, which might affect the metabolism of some steroid hormones (Rice and O'Keefe, 1995). Whatever the mechanism of action, several physiological functions that are controlled by steroid hormones can be altered by exposure of mammals to PCBs, and reproduction appears to be the most sensitive endpoint for PCB toxicity in mammals (Rice and O'Keefe, 1995). Given this information, the screening ecological risk assessment should include potential exposure pathways for mammals to PCBs.

Several possible exposure pathways were evaluated for mammals. PCBs are not highly volatile, so inhalation of PCBs by animals would not be an important exposure pathway. PCBs in soils generally are not taken up by most plants, but are accumulated by soil macroinvertebrates. Thus, herbivores, such as voles and rabbits, would not be exposed to PCBs in most of their diets; whereas insectivores, such as shrews, or omnivores, such as deer mice, could be exposed to accumulated PCBs in their diets. PCBs also are known to biomagnify in terrestrial food chains; therefore, the ingestion exposure route needs evaluation, and shrews and/or deer mice would be appropriate mammalian receptors to evaluate in this exposure pathway.

Potential reproductive effects on predators that feed on shrews or mice also would be important to evaluate. The literature indicated that exposure to PCBs through the food chain could cause reproductive impairment in predatory birds through a similar mechanism as in mammals. The prey of red-tail hawks include voles, deer mice, and various insects. Thus, this raptor could be at risk of adverse reproductive effects.

Ecological effects evaluation. No-observed-adverse-effect levels (NOAELs) for the effects of PCBs and other contaminants at the site on mammals, birds, and other biota were identified in the literature.

STEP 2: SCREENING-LEVEL EXPOSURE ESTIMATE AND RISK CALCULATION

Exposure estimate. For the screening-level risk calculation, the highest PCB and other contaminant levels measured on site were used to estimate exposures.

Risk calculation. The potential contaminants of concern were screened based on NOAELs for exposure routes appropriate to each contaminant. Based on this screen, PCBs were confirmed to be the only contaminants of concern to small mammals, and possibly to birds, based on the levels measured at this site. Thus, at the SMDP, the risk manager and lead risk assessor decided to continue to Step 3 of the ecological risk assessment process.

STEP 3: BASELINE RISK ASSESSMENT PROBLEM FORMULATION

The screening-level ecological risk assessment confirmed that PCBs are of concern to small mammals based on the levels measured at the site and suggested that predatory birds might be at risk from PCBs that accumulate in some of their mammalian prey.

Ecotoxicity literature review. A literature review was conducted to evaluate potential reproductive effects in birds. PCBs have been implicated as a cause of reduced reproductive success of piscivorous birds (e.g., cormorants, terns) in the Great Lakes (Kubiak et al., 1989; Fox et al., 1991). Limited information was available on the effects of PCBs to red-tailed hawks. A study on American kestrel indicated that consumption of 33 mg/kgBW-day PCBs resulted in a significant decrease in sperm concentration in male kestrels (Bird et al., 1983). Implications of this decrease for mating success in kestrels was not evaluated in the study, but studies on other bird species indicate that it could increase the incidence of infertile eggs and therefore reduce the number of young fledged per pair. The Great Lakes International Joint Commission (IJC) recommends 0.1 mg/kg total PCBs as a prey tissue level that will protect predatory birds and mammals (IJC, 1988). (This number is used as an illustration and not to suggest that this particular level is appropriate for a given site.)

Exposure pathways. The complete exposure pathways identified during Steps 1 were considered appropriate for the baseline ecological risk assessment as well.

Assessment endpoints and conceptual model. Based on the screening-level risk assessment for small mammals and the results of the ecotoxicity literature search for birds, a conceptual model was initiated for the site, which included consideration of predatory birds (e.g., red-tailed hawks) and their prey. The ecological risk assessor and the risk manager agreed (SMDP) that assessment endpoints for the site would be the protection of

small mammals and predatory birds from reproductive impairment caused by PCBs that had accumulated in their prey.

An exposure pathway diagram was developed for the conceptual model to identify the exposure pathways by which predatory birds could be exposed to PCBs originating in the soil at the site (see Exhibit A-3). While voles may be prevalent at the site, they are not part of the exposure pathway for predators because they are herbivorous and PCBs do not accumulate in plants. Deer mice (*Peromyscus maniculatus*), on the other hand, also are abundant at the site and, being omnivorous, are likely to be exposed to PCBs that have accumulated in the insect component of their diet. Preliminary calculations indicated that environmental levels likely to cause reproductive effects in predatory birds are lower than those likely to cause reproductive effects in mice because mice feed lower in the food chain than do raptors. The assessment endpoint was therefore restricted to reproductive impairment in predatory birds.

Risk questions. Based on the conceptual model, one question was whether predatory birds could consume a high enough dose of PCBs in their diet to impair their reproduction. Given the presence of red-tailed hawks on site, the question was refined to ask whether that species could consume sufficient quantities of PCBs in their diet to affect reproduction.

STEP 4: MEASUREMENT ENDPOINTS AND STUDY DESIGN

Measurement endpoints. To determine whether PCB levels in prey of the red-tailed hawk exceed levels that might impair their reproduction, PCB levels would be measured in deer mice taken from the site (of all of the species in the diet of the red-tailed hawk, deer mice are assumed to accumulate the highest levels of PCBs). Based on estimated prey ingestion rates for red-tailed hawks, a total PCB dose would be estimated from the measured PCB concentrations in the mice.

Study design. The available measures of PCB concentrations in soil at the site indicated a gradient of decreasing PCB concentration with increasing distance from the unlined lagoon. Three locations along this gradient were selected to measure PCB concentrations in deer mice. The study design specified that eight deer mice of the same size and sex would be collected at each location. Each mouse should be approximately 20 grams so that contaminant levels can be measured in individual mice. With concentrations measured in eight individual mice, it is possible to estimate a mean concentration and an upper confidence limit of the mean concentration in deer mice for the location. In addition, QA/QC requirements dictate that an additional eight deer mice should be collected at one location.

For this site, it was necessary to verify that sufficient numbers of deer mice of the specified size would be present to meet the sampling requirements. In addition, habitat

EXHIBIT A-3
Conceptual Model for the Terrestrial PCB Site

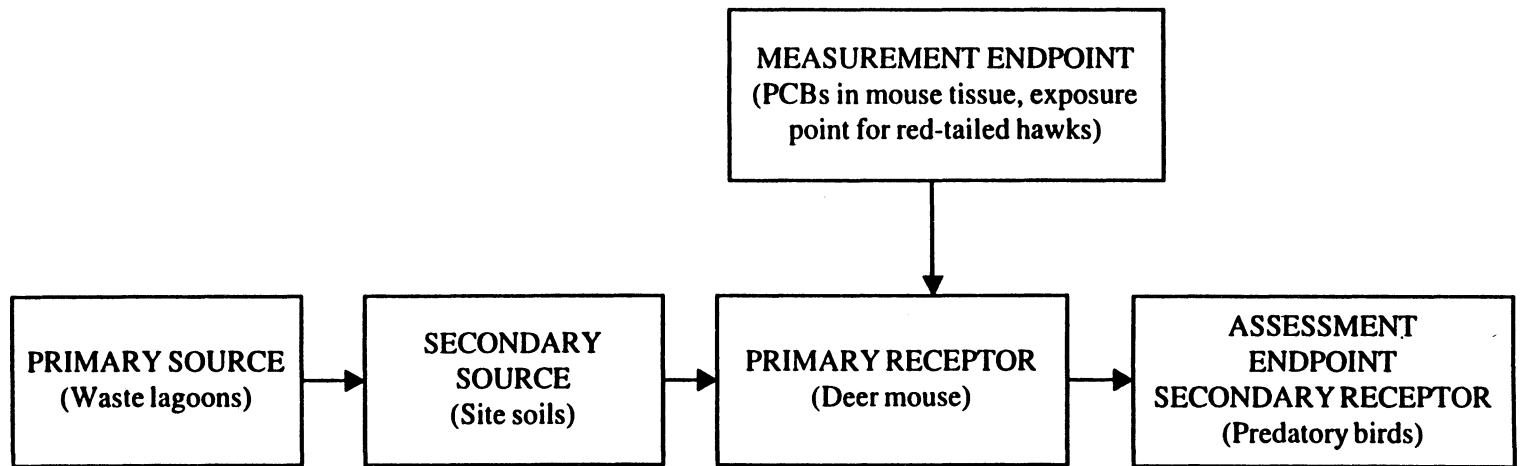

conditions needed to be evaluated to determine what trapping techniques would work at the targeted locations.

The study design specified further that the hazard quotient (HQ) method would be used to estimate the risk of reproductive impairment in the red-tailed hawk from exposure to PCBs in their prey. To determine the HQ, the measured DDT concentrations in deer mice is divided by the LOAEL of 33 mg/kgBW-day for a decrease in sperm concentration in kestrels. To estimate the dose to the red-tailed hawk, the PCB concentrations in deer mice is multiplied by the quantity of deer mice that could be ingested by a red-tailed hawk each day and divided by the body weight of the hawk. This dose is adjusted by a factor that corresponds to the proportion of the diet of a red-tailed hawk that would come from the contaminated area. This area use factor is a function of the home range size of the hawks relative to the area of contamination. A HQ of greater than one implies that impacts due to site contamination are likely, and an HQ of less than one implies impacts due to site contaminants are unlikely.

STEP 5: FIELD VERIFICATION OF STUDY DESIGN

A field assessment using several trapping techniques was conducted to determine (1) which technique was most effective for capturing deer mice at the site and (2) whether the technique would yield sufficient numbers of mice over 20 grams to meet the specified sampling design. On the first evening of the field assessment, two survey lines of 10 live traps were set for deer mice in typical old-field habitat in the area believed to contain the desired DDT concentration gradient for the study design. At the beginning of the second day, the traps were retrieved. Two deer mice over 20 grams were captured in each of the survey lines. These results indicated that collection of deer mice over a period of a week or less with this number and spacing of live traps should be adequate to meet the study objectives.

REFERENCES

- Aulerich, R.J.; Bursian, S.J.; Breslin, W.J.; et al. 1985. Toxicological manifestations of 2,4,5-,2',4',5'-, 2,3,6,2',3',6'-, and 3,4,5,3',4',5'-hexachlorobiphenyl and Aroclor 1254 in mink. *J. Toxicol. Environ. Health* 15: 63-79.
- Bird, D.M.; Tucker, P.H.; Fox, G.A.; Lague, P.C. 1983. Synergistic effects of Aroclor 1254 and mirex on the semen characteristics of American kestrels. *Arch. Environ. Contam. Toxicol.* 12: 633-640.
- Fox, G.A.; Collins, B.; Hayaskawa, E.; et al. 1991. Reproductive outcomes in colonial fish-eating birds: a biomarker for developmental toxicants in Great Lakes food chains. II. Spatial variation in the occurrence and prevalence of bill defects in young double-crested cormorants in the Great Lakes. *J. Great Lakes Res.* 17:158-167.

- International Joint Commission (IJC) of United States and Canada. 1988. Great Lakes Water Quality Agreement. Amended by protocol. Signed 18 November 1987. Ottawa, Canada.
- Kamrin, M.A.; Ringer, R.K. 1996. Toxicological implications of PCB residues in mammals. In: Beyer, W.N.; Heinz, G.H.; Redmon-Norwood, A.R. (eds.). *Environmental Contaminants in Wildlife: Interpreting Tissue Concentrations*. A Special Publication of the Society of Environmental Toxicology and Chemistry (SETAC), La Point, T.W. (series ed.). Boca Raton, FL: CRC Press, Inc., Lewis Publishers. pp 153-164.
- Kubiak, T.J.; Harris, H.J.; Smith, L.M.; et al. 1989. Microcontaminants and reproductive impairment of the Forster's tern on Green Bay, Lake Michigan—1983. *Arch. Environ. Contam. Toxicol.* 18: 706-727.
- Rice, C.P.; O'Keefe, P. 1995. Sources, pathways, and effects of PCBs, dioxins, and dibenzofurans. In: Hoffman, D.J.; Rattner, B.A.; Burton, G.A. Jr.; Cairns, J., Jr. (eds.). *Handbook of Ecotoxicology*. Ann Arbor, MI: CRC Press, Inc., Lewis Publishers.
- Ringer, R.K.; Aulerich, R.J.; Zabik, M. 1972. Effect of dietary polychlorinated biphenyls on growth and reproduction of mink. Extended abstract. ACS (American Chemical Society) 164th Annu. Meet. 12: 149-154.
- Wren, C.D. 1991. Cause-effect linkages between chemicals and populations of mink (*Mustela vison*) and otter (*Lutra canadensis*) in the Great Lakes basin. *J. Toxicol. Environ. Health* 33: 549-585.

APPENDIX B

**REPRESENTATIVE SAMPLING GUIDANCE DOCUMENT,
VOLUME 3: ECOLOGICAL**

OSWER Directive XXXX.XX
EPA 540/R/94/XXX
PBxx-xxxxxx
May 1997

DRAFT

SUPERFUND PROGRAM

REPRESENTATIVE SAMPLING GUIDANCE

VOLUME 3: BIOLOGICAL

INTERIM FINAL

Environmental Response Team Center

Office of Emergency and Remedial Response
Office of Solid Waste and Emergency Response

U.S. Environmental Protection Agency
Washington, DC 20460

Notice

The policies and procedures established in this document are intended solely for the guidance of government personnel, for use in the Superfund Program. They are not intended, and cannot be relied upon, to create any rights, substantive or procedural, enforceable by any party in litigation with the United States. The Agency reserves the right to act at variance with these policies and procedures and to change them at any time without public notice.

For more information on Biological Sampling procedures, refer to the *Compendium of ERT Toxicity Testing Procedures*, OSWER Directive 9360-4-08, EPA/540/P-91/009 (U.S. EPA 1991a). Topics covered in this compendium include: toxicity testing; and surface water and sediment sampling.

Please note that the procedures in this document should only be used by individuals properly trained and certified under a 40 Hour Hazardous Waste Site Training Course that meets the requirements set forth in 29 CFR 1910.120(e)(3). It should not be used to replace or supersede any information obtained in a 40 Hour Hazardous Waste Site Training Course.

Questions, comments, and recommendations are welcomed regarding the *Superfund Program Representative Sampling Guidance, Volume 3 -- Biological*. Send remarks to:

Mark Sprenger Ph.D. - Environmental Scientist
David Charters Ph.D. - Environmental Scientist
U.S. EPA - Environmental Response Center (ERC)
Building 18, MS-101
2890 Woodbridge Avenue
Edison, NJ 08837-3679

For additional copies of the *Superfund Program Representative Sampling Guidance, Volume 3 -- Biological*, contact:

National Technical Information Services
5285 Port Royal Road
Springfield, VA 22161
Phone (703) 487-4650

U.S. EPA employees can order a copy by calling the ERC at (908) 321-4212

Disclaimer

This document has been reviewed in accordance with U.S. Environmental Protection Agency policy and approved for publication. Mention of trade names or commercial products does not constitute endorsement or recommendation for use.

The following trade names are mentioned in this document:

Havahart® - Allcock Manufacturing Co., Lititz, PA

Longworth - Longworth Scientific Instrument Company, Ltd., England

Museum Special - Woodstream Corporation, Lititz, PA

Sherman - H.B. Sherman Traps, Tallahassee, FL

This page intentionally left blank.

CONTENTS

Notice	ii
Disclaimer	iii
List of Figures	viii
List of Tables	vii
Preface	ix
1.0 INTRODUCTION	1
1.1 Objective and Scope	1
1.2 Risk Assessment Overview	1
1.3 Conceptual Site Model	2
1.4 Data Quality Objectives	3
1.5 Technical Assistance	4
2.0 BIOLOGICAL/ECOLOGICAL ASSESSMENT APPROACHES	6
2.1 Introduction	6
2.2 RISK EVALUATION	6
2.2.1 Literature Screening Values	6
2.2.2 Risk Calculations	6
2.2.3 Standard Field Studies	6
2.2.3.1 Reference Area Selection	6
2.2.3.2 Receptor Selection	7
2.2.3.3 Exposure-Response Relationships	8
2.2.3.4 Chemical Residue Studies	8
2.2.3.5 Population/Community Response Studies	9
2.2.3.6 Toxicity Testing/Bioassays	9
3.0 BIOLOGICAL SAMPLING METHODS	11
3.1 Chemical Residue Studies	11
3.1.1 Collection Methods	11
3.1.1.1 Comparability Considerations	12
3.1.1.2 Mammals	12
3.1.1.3 Fish	13
3.1.1.4 Vegetation	13
3.1.2 Sample Handling and Preparation	14
3.1.3 Analytical Methods	14

3.2	Population/community Response Studies	15
3.2.1	Terrestrial Vertebrate Surveys	15
3.2.2	Benthic Macroinvertebrate Surveys	15
3.2.2.1	Rapid Bioassessment Protocols for Benthic Communities	16
3.2.2.2	General Benthological Surveys	16
3.2.2.3	Reference Stations	16
3.2.2.4	Equipment for Benthic Surveys	16
3.2.3	Fish Biosurveys	17
3.2.3.1	Rapid Bioassessment Protocols for Fish Biosurveys	17
3.3	Toxicity Tests	17
3.3.1	Examples of Acute Toxicity Tests	17
3.3.2	Examples of Chronic Toxicity Tests	18
4.0	QUALITY ASSURANCE/QUALITY CONTROL	21
4.1	Introduction	21
4.2	Data Categories	21
4.3	Sources of Error	21
4.3.1	Sampling Design	21
4.3.2	Sampling Methodology and Sample Handling	22
4.3.3	Sample Homogeneity	22
4.3.4	Sample Analysis	22
4.4	QA/QC Samples	23
4.4.1	Replicate Samples	23
4.4.2	Collocated Samples	24
4.4.3	Reference Samples	25
4.4.4	Rinsate Blank Samples	25
4.4.5	Field Blank Samples	25
4.4.6	Trip Blank Samples	25
4.4.7	Performance Evaluation/Laboratory Control Samples	25
4.4.8	Controls	25
4.4.9	Matrix Spike/Matrix Spike Duplicate Samples	26
4.4.10	Laboratory Duplicate Samples	26
4.5	Data Evaluation	26
4.5.1	Evaluation of Analytical Error	26
4.5.2	Data Validation	26
5.0	DATA ANALYSIS AND INTERPRETATION	27
5.1	Introduction	27
5.2	Data Presentation And Analysis	27

5.2.1	Data Presentation Techniques	27
5.2.2	Descriptive Statistics	27
5.2.3	Hypothesis Testing	27
5.3	Data Interpretation	28
5.3.1	Chemical Residue Studies	28
5.3.2	Population/Community Studies	28
5.3.3	Toxicity Testing	28
5.3.4	Risk Calculation	28
APPENDIX A - CHECKLIST FOR ECOLOGICAL ASSESSMENT/SAMPLING		30
APPENDIX B - EXAMPLE OF FLOW DIAGRAM FOR CONCEPTUAL SITE MODEL		47
APPENDIX C - EXAMPLE SITES		50
REFERENCES		53

List of Figures

FIGURE 1 - Conceptual Site Model 5
FIGURE 2 - Common Mammal Traps 19
FIGURE 3 - Illustrations of Sample Plots 29

List of Tables

TABLE 1 - Reference List of Standard Operating Procedures -- Ecological Sampling Methods 20

Preface

This document is third in a series of guidance documents designed to assist Superfund Program Site Managers such as On-Scene Coordinators (OSCs), Site Assessment Managers (SAMs), and other field staff in obtaining representative samples at Superfund sites. It is intended to assist Superfund Program personnel in evaluating and documenting environmental threat in support of management decisions, including whether or not to pursue a response action. This document provides general guidance for collecting representative biological samples (i.e., measurement endpoints) once it has been determined by the Site Manager that additional sampling will assist in evaluating the potential for ecological risk. In addition, this document will:

- Assist field personnel in representative biological sampling within the objectives and scope of the Superfund Program
- Facilitate the use of ecological assessments as an integral part of the overall site evaluation process
- Assist the Site Manager in determining whether an environmental threat exists and what methods are available to assess that threat

This document is intended to be used in conjunction with other existing guidance documents, most notably, *Ecological Risk Assessment Guidance for Superfund: Process for Designing and Conducting Ecological Risk Assessments*, OSWER, EPA 540-R-97/006.

The objective of representative sampling is to ensure that a sample or a group of samples accurately characterizes site conditions. Biological information collected in this manner complements existing ecological assessment methods. Representative sampling within the objectives of the Superfund Program is used to:

- promote awareness of biological and ecological issues
- define the parameters of concern and the data quality objectives (DQOs)
- develop a biological sampling plan
- define biological sampling methods and equipment
- identify and collect suitable quality assurance/quality control (QA/QC) samples
- interpret and present the analytical and biological data

The National Contingency Plan (NCP) requires that short-term response (removal) actions contribute to the efficient performance of any long-term site remediation, to the extent applicable. Use of this document will help determine if biological sampling should be conducted at a site, and if so, what samples will assist program personnel in the collection of information required to make such a determination.

Identification and assessment of potential environmental threats are important elements for the Site Manager to understand. These activities can be accomplished through ecological assessments such as biological sampling. This document focuses on the performance of ecological assessment screening approaches, more detailed ecological assessment approaches, and biological sampling methods.

1.0 INTRODUCTION

1.1 OBJECTIVE AND SCOPE

This document is intended to assist Superfund Program personnel in evaluating and documenting environmental threat in support of management decisions. It presents ecological assessment and sampling as tools in meeting the objectives of the Superfund Program, which include:

- Determine threat to public health, welfare, and the environment
- Determine the need for long-term action
- Develop containment and control strategies
- Determine appropriate treatment and disposal options
- Document attainment of clean-up goals

This document is intended to assist Superfund Program personnel in obtaining scientifically valid and defensible environmental data for the overall decision-making process of site actions. Both the Comprehensive Environmental Response, Compensation, and Liability Act (CERCLA) [§104(a)(1)], as amended by the Superfund Amendments and Reauthorization Act (SARA), and the NCP [§300.400(a)(2)], require that the United States Environmental Protection Agency (U.S. EPA) "protect human health and the environment."

Environmental threats may be independent of human health threats, whether they co-exist at a site or are the result of the same causative agents. It is therefore important to determine and document potential, substantial, and/or imminent threats to the environment separately from threats to human health.

Representative sampling ensures that a sample or a group of sample accurately characterizes site conditions. Representative biological sampling and ecological risk assessment include, but are not limited to, the collection of site information and the collection of samples for chemical or toxicological analyses. Biological sampling is dependent upon specific site requirements during limited response actions or in emergency response situations. Applying the methods of collecting environmental information, as outlined in this document, can facilitate the decision-making process (e.g., during chemical spill incidents).

The collection of representative samples is critical to the site evaluation process since all data interpretation assumes proper sample collection. Samples collected which inadvertently or intentionally direct the generated data toward a conclusion are biased and therefore not representative.

This document provides Superfund Program personnel with general guidance for collecting representative biological samples (i.e., measurement endpoints, [see Section 1.2 for the definition of measurement endpoint]). Representative biological sampling is conducted once the Site Manager has determined that additional sampling may assist in evaluating the potential for ecological risk. This determination should be made in consultation with a trained ecologist or biologist. The topics covered in this document include sampling methods and equipment, QA/QC, and data analysis and interpretation.

The appendices in this document provide several types of assistance. Appendix A provides a checklist for initial ecological assessment and sampling. Appendix B provides an example flow diagram for the development of a conceptual site model. Appendix C provides examples of how the checklist for ecological assessment/sampling is used to formulate a conceptual site model that leads up to the design of a site investigation.

This document is intended to be used in conjunction with other existing guidance documents, most notably, *Ecological Risk Assessment Guidance for Superfund: Process for Designing and Conducting Ecological Risk Assessments*, EPA 540-R-97/006 (U.S. EPA 1997).

1.2 RISK ASSESSMENT OVERVIEW

The term ecological risk assessment (ERA), as used in this document, and as defined in *Ecological Risk Assessment Guidance for Superfund: Process for Designing and Conducting Ecological Risk Assessments*, OSWER, EPA 540-R-97/006 (U.S. EPA 1997) refers to:

"... a qualitative and/or quantitative appraisal of the actual or potential impacts of a hazardous waste site on plants and animals other than humans and domesticated species."

Risk assessments are an integral part of the Superfund

process and are conducted as part of the baseline risk assessment for the remedial investigation and feasibility study (RI/FS). The RI is defined by a characterization of the nature and extent of contamination, and ecological and human health risk assessments. The nature and extent of contamination determines the chemicals present on the site. The ecological and human health risk assessments determine if the concentrations threaten the environment and human health.

An ecological risk assessment is a formal process that integrates knowledge about an environmental contaminant (i.e., exposure assessment) and its potential effects to ecological receptors (i.e., hazard assessment). The process evaluates the likelihood that adverse ecological effects may occur or are occurring as a result of exposure to a stressor. As defined by U.S. EPA (1992), a stressor is any physical, chemical or biological entity that can induce an adverse ecological response. Adverse responses can range from sublethal chronic effects in an individual organism to a loss of ecosystem function.

Although stressors can be biological (e.g., introduced species), in the Superfund Program substances designated as hazardous under CERCLA are usually the stressors of concern. A risk does not exist unless (1) the stressor has the ability to cause one or more adverse effects, and (2) it co-occurs with or contacts an ecological component long enough and at sufficient intensity to elicit the identified adverse effect.

The risk assessment process also involves the identification of assessment and measurement endpoints. Assessment endpoints are explicit expressions of the actual environmental values (e.g., ecological resources) that are to be protected. A measurement endpoint is a measurable biological response to a stressor that can be related to the valued characteristic chosen as the assessment endpoint (U.S. EPA 1997). Biological samples are collected from a site to represent these measurement endpoints. See Section 2.2 for a detailed discussion of assessment and measurement endpoints.

Except where required under other regulations, issues such as restoration, mitigation, and replacement are important to the program but are reserved for investigations that may or may not be included in the RI phase. During the management decision process of selecting the preferred remedial option leading to the Record of Decision (ROD), mitigation and restoration issues should be addressed. Note that these issues are not necessarily issues within the baseline ecological risk

assessment.

Guidelines for human health risk assessment have been established; however, comparable protocols for ecological risk assessment do not currently exist. *Ecological Risk Assessment Guidance for Superfund: Process for Designing and Conducting Ecological Risk Assessments.* (U.S. EPA 1997) provides conceptual guidance and explains how to design and conduct ecological risk assessments for a CERCLA RI/FS. The *Framework for Ecological Risk Assessment* (U.S. EPA 1992) provides an Agency-wide structure for conducting ecological risk assessments and describes the basic elements for evaluating site-specific adverse effects of stressors on the environment. These documents should be referred to for specific information regarding the risk assessment process.

While the ecological risk assessment is a necessary first step in a "natural resource damage assessment" to provide a causal link, it is not a damage evaluation. A natural resource damage assessment may be conducted at any Superfund site at the discretion of the Natural Resource Trustees. The portion of the damage assessment beyond the risk assessment is the responsibility of the Natural Resource Trustees, not of the U.S. EPA. Therefore, natural resource damage assessment is not addressed in this guidance.

1.3 CONCEPTUAL SITE MODEL

A conceptual site model is an integral part of a site investigation and/or ecological risk assessment as it provides the framework from which the study design is structured. The conceptual site model follows contaminants from their sources, through transport and fate pathways (air, soil, surface water, groundwater), to the ecological receptors. The conceptual model is a strong tool in the development of a representative sampling plan and is a requirement when conducting an ecological risk assessment. It assists the Site Manager in evaluating the interaction of different site features (e.g., drainage systems and the surrounding topography), thereby ensuring that contaminant sources, pathways, and ecological or human receptors throughout the site have been considered before sampling locations, techniques, and media are chosen.

Frequently, a conceptual model is created as a site map (Figure 1) or flow diagram that describes the potential movement of contaminants to site receptors (see Appendix B). Important considerations when creating a conceptual model are:

- The state(s) (or chemical form) of each contaminant and its potential mobility through various media
- Site topographical features
- Meteorological conditions (e.g., climate, precipitation, humidity, wind direction/speed)
- Wildlife area utilization.

Preliminary and historical site information may provide the identification of the contaminant(s) of concern and the level(s) of the contamination. A sampling plan should be developed from the conceptual model based on the selected assessment endpoints.

The conceptual site model (Figure 1) is applied to this document, *Representative Sampling Guidance Volume 3: Biological*. Based on the model, you can approximate:

- Potential Sources

hazardous waste site (waste pile, lagoon, emissions), drum dump (runoff, leachate), agricultural (runoff, dust, and particulates)

- Potential Exposure Pathways

- *ingestion*
waste contained in the pile on the hazardous waste site; soil particles near the waste pile; drum dump; or area of agricultural activity
- *inhalation*
dust and particulates from waste pile, drum dump, or area of agricultural activity
- *absorption/direct contact*
soil near waste pile, drum dump, or area of agricultural activity and surface water downstream of sources

- Potential Migration Pathways

- *air (particulates and gases) from drum dump and area of agricultural activity*
- *soil (runoff) from the hazardous waste site, drum dump, and agricultural runoff*
- *surface water (river & lake) from hazardous waste site and agricultural runoff*
- *groundwater (aquifer) from drum dump leachate.*

- Potential Receptors of Concern (and associated potential routes)

- *wetland vegetation/mammals/invertebrates if suspected to be in contact with potentially contaminated soil and surface water*

- *riverine vegetation/aquatic organisms if suspected to be in contact with potentially contaminated surface water and soil*
- *lake vegetation/mammals/aquatic organisms if suspected to be in contact with potentially contaminated surface water and leachate.*

1.4 DATA QUALITY OBJECTIVES

Data quality objectives (DQOs) state the level of uncertainty that is acceptable from data collection activities. DQOs also define the data quality necessary to make a certain decision. Consider the following when establishing DQOs for a particular project:

- Decision(s) to be made or question(s) to be answered;
- Why environmental data are needed and how the results will be used;
- Time and resource constraints on data collection;
- Descriptions of the environmental data to be collected;
- Applicable model or data interpretation method used to arrive at a conclusion;
- Detection limits for analytes of concern; and
- Sampling and analytical error.

In addition to these considerations, the quality assurance components of precision, accuracy (bias), completeness, representativeness, and comparability should also be considered. Quality assurance components are defined as follows:

- Precision -- measurement of variability in the data collection process.
- Accuracy (bias) -- measurement of bias in the analytical process. The term "bias" throughout this document refers to the QA/QC accuracy component.
- Completeness -- percentage of sampling measurements which are judged to be valid.
- Representativeness -- degree to which sample data accurately and precisely represent the

characteristics of the site contaminants and their concentrations.

- **Comparability -- evaluation of the similarity of conditions (e.g., sample depth, sample homogeneity) under which separate sets of data are produced.**

Many of the DQOs and quality assurance considerations for soil, sediment, and water sampling are also applicable to biological sampling. However, there are also additional considerations that are specific to biological sampling.

- **Is biological data needed to answer the question(s) and, if so, how will the data be used;**
- **Seasonal, logistical, resource, and legal constraints on biological specimen collection;**
- **What component of the biological system will be collected or evaluated (i.e., tissue samples, whole organisms, population data, community data, habitat data);**
- **The specific model or interpretation scheme to be utilized on the data set;**
- **The temporal, spatial, and behavioral variability inherent in natural systems.**

Quality assurance/quality control (QA/QC) objectives are discussed further in Chapter 4.

1.5 TECHNICAL ASSISTANCE

In this document, it is assumed that technical specialists are available to assist Site Managers and other site personnel in determining the best approach to ecological assessment. This assistance ensures that all approaches are up-to-date and that best professional judgment is exercised. Refer to Appendix A for more information.

Support in designing and evaluating ecological assessments is currently available from regional technical assistance groups such as Biological Technical Assistance Groups (BTAGs). Support is also available from the Environmental Response Team Center (ERTC) as well as from other sources within each region.

**FIGURE 1:
CONCEPTUAL
SITE MODEL**

WIND ROSE

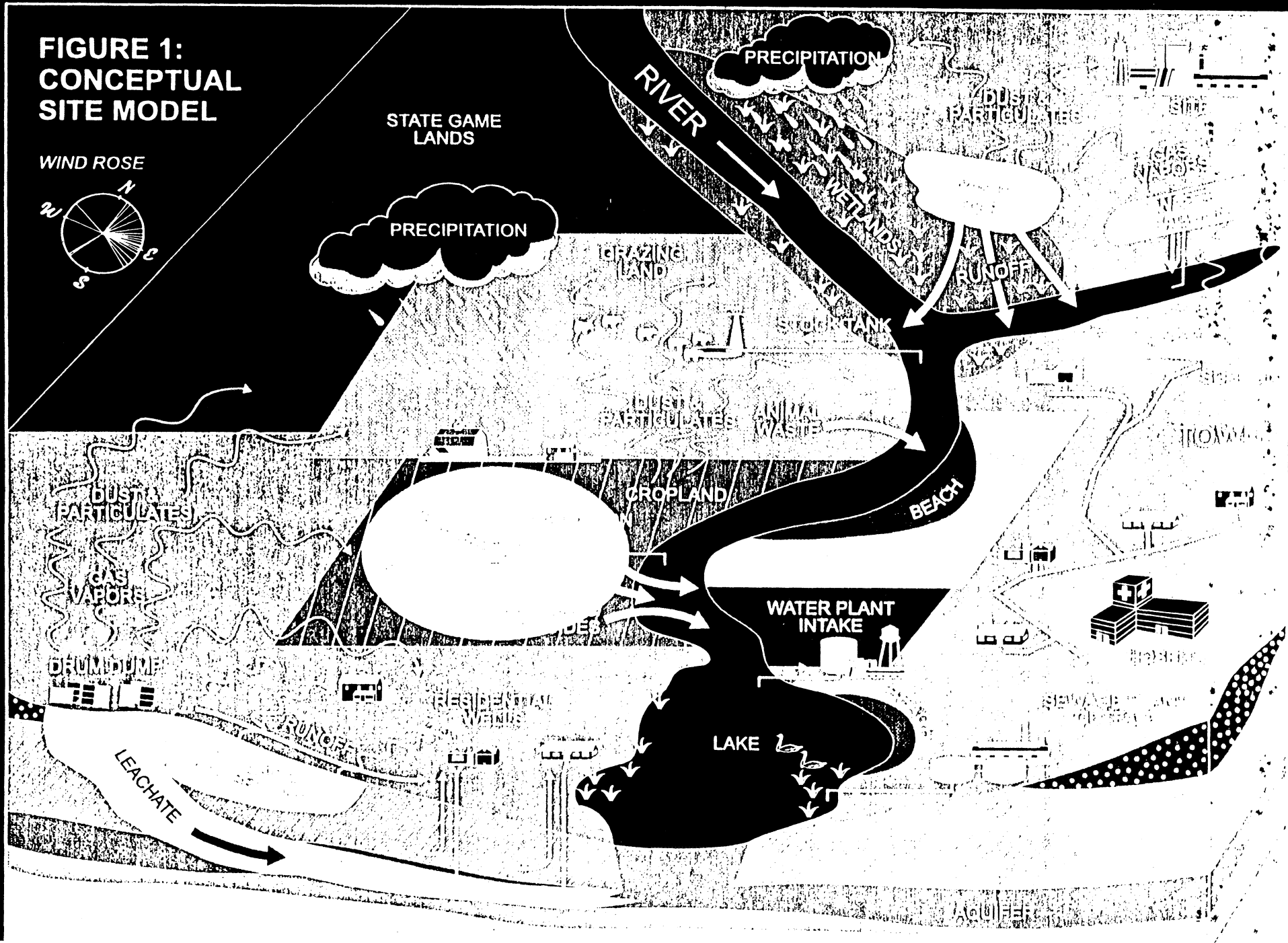
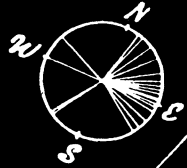

2.0 BIOLOGICAL/ECOLOGICAL ASSESSMENT APPROACHES

2.1 INTRODUCTION

Biological assessments vary in their level of effort, components, and complexity, depending upon the objectives of the study and specific site conditions. An assessment may consist of literature-based risk evaluations and/or site-specific studies (e.g., population/community studies, toxicity tests/bioassays, and tissue residue analyses).

Superfund Program personnel (RPMs and OSCs) may be limited to completing the ecological checklist (Appendix A) during the Preliminary Site Evaluations and to consulting an ecological specialist if it is determined that additional field data are required. The checklist is designed to be completed by one person during an initial site visit. The checklist provides baseline data, is useful in designing sampling objectives, and requires a few hours to complete in the field.

When the Site Manager determines that additional data collection is needed at a response site, the personnel and other resources required depends on the selected approach and the site complexity.

To determine which biological assessment approach or combination of approaches is appropriate for a given site or situation, several factors must be considered. These include what management decisions will ultimately need to be made based on the data; what are the study objectives; and what should be the appropriate level of effort to obtain knowledge of contaminant fate/ transport and ecotoxicity.

2.2 RISK EVALUATION

Three common approaches to evaluating environmental risk to ecological receptors are (1) the use of literature screening values (e.g., literature toxicity values) for comparison to site-specific contaminant levels, (2) a "desk-top" risk assessment which can model existing site-specific contaminant data to ecological receptors for subsequent comparison to literature toxicity values, and (3) field investigation/laboratory analysis that involves a site investigation (which may utilize existing contaminant data for support) and laboratory analysis of contaminant levels in media and/or experimentation using bioassay procedures. These three approaches are described in further detail next.

2.2.1 Literature Screening Values

To determine the environmental effects of contaminants at a hazardous waste site, the levels of contaminants found may be compared to literature toxicity screening values or established screening criteria. These values should be derived from studies that involve testing of the same matrix and a similar organism of concern. Most simply stated, if the contaminant levels on the site are above the established criteria, further evaluation of the site may be necessary to determine the presence of risk. Site contaminant levels that are lower than established criteria may indicate that no further evaluation is necessary at the site for that contaminant.

2.2.2 Risk Calculations

The "desk-top" risk calculation approach compares site contaminants to information from studies found in technical literature. This type of evaluation can serve as a screening assessment or as a tier in a more complex evaluation. Since many assumptions must be made due to limited site-specific information, risk calculations are necessarily conservative. The collection and inclusion of site-specific field data can reduce the number and/or the magnitude of these "conservative" assumptions, thereby generating a more realistic calculation of potential risk. (See Chapter 5.0 for a complete discussion on risk calculations.)

2.2.3 Standard Field Studies

Two important aspects of conducting a field study that warrant discussion are the selection of a reference area and the selection of the receptors of concern. These are important to establish prior to conducting a field study.

2.2.3.1 Reference Area Selection

A reference area is defined in this document as an area that is outside the chemical influence of the site but possesses similar characteristics (e.g., habitat, substrate type) that allows for the comparison of data between the impacted area (i.e., the site) and the unimpacted area (i.e., the reference area). Reference areas can provide information regarding naturally occurring compounds and the existence of any regional contamination independent of the site. They can help determine if contaminants are ubiquitous in the area and can separate site-related issues

from non-site related issues.

The reference area must be of similar habitat type and support a species composition similar to the study area. The collection and analysis of samples from a reference area can support site-specific decisions regarding uptake, body burden, and accumulation of chemicals and toxicity.

The reference area should be outside the area of influence of the site and if possible, in an area of minimal contamination or disturbance. Location of reference areas in urban or industrial areas is frequently difficult, but an acceptable reference area is usually critical to the successful use of ecological assessment methods.

2.2.3.2 Receptor Selection

The selection of a receptor is dependent upon the objectives of the study and the contaminants present. The first step is to determine the toxicity characteristics of the contaminants (i.e., acute, chronic, bioaccumulative, or non-persistent). The next step is to determine the exposure route of the chemical (i.e., dermal, ingestion, inhalation).

Selection of the receptor or group of receptors is a component of establishing the measurement endpoint in the study design. When discussing the term measurement endpoint, it is useful to first define a related concept, the assessment endpoint. An assessment endpoint is defined as "an explicit expression of the environmental value that is to be protected." For example, "maintaining aquatic community composition and structure downstream of a site similar to that upstream of the site" is an explicit assessment endpoint. Inherent in this assessment endpoint is the process of receptor selection that would most appropriately answer the question that the endpoint raises. Related to this assessment endpoint is the measurement endpoint which is defined as "a measurable ecological characteristic that is related to the valued characteristic chosen as the assessment endpoint." For example, measurements of biological effects such as mortality, reproduction, or growth of an invertebrate community are measurement endpoints. Establishing these endpoints will ensure (1) that the proper receptor will be selected to best answer the questions raised by the assessment and measurement endpoints, and (2) that the focus of the study remains on the component of the environment that may be used as the basis for decision.

There are a number of factors that must be considered when selecting a target species. The behavioral habits and lifestyle of the species must be consistent with the

environmental fate and transport of the contaminants of interest as well as pathways of exposure to receptor species. For example, if the contaminants of concern at the site are PCBs that are bioaccumulative, a mammal such as a mink could be selected for the study since this species is documented to be sensitive to the bioaccumulation of PCBs. The mink in this case has been selected to be used for establishing the measurement endpoint that is representative of piscivorous mammals. However, it may not be feasible to collect mink for study due to their low availability in a given area. Therefore, the food items of the mink (e.g., small mammals, aquatic vertebrates and invertebrates) may be collected and analyzed for PCBs as an alternative means of evaluating the risk to mink. The resulting residue data may be utilized to produce a dose model. From this model, a reference dose value may be determined from which the probable effects to mink calculated.

The movement patterns of a measurement endpoint are also important during the receptor selection process. Species that are migratory or that have large feeding ranges are more difficult to link to site exposure than those which are sessile, territorial, or have limited movement patterns.

Ecological field studies offer direct or corroborative evidence of a link between contamination and ecological effects. Such evidence includes:

- Reduction in population sizes of species that can not be otherwise explained by naturally occurring population cycles
- Absence of species normally occurring in the habitat and geographical distribution
- Dominance of species associated primarily with stressed habitat
- Changes in community diversity or trophic structure relative to a reference location
- High incidence of lesions, tumors, or other pathologies
- Development of exposure response relationships.

Ecologists usually compare data of observed adverse effects to information obtained from a reference area not affected by site contamination. To accomplish this, chemical and biological data should be collected simultaneously and then compared to determine if a correlation exists between contaminant concentrations and ecological effects (U.S. EPA 1991b). The simultaneous collection of the data is important in reducing the effect of temporal variability as a factor in the correlation analysis.

The type of field study selected is directed by the contaminants present linked to the assessment endpoint. Prior to choosing a specific study approach, the site contaminant must be determined using information about known or suspected site contaminants and how the nature of these contaminants may be modified by several environmental and ecotoxicological factors. In addition, evaluation of chemical fate and transport information is necessary to determine the appropriate matrix and technique.

Contaminants can be a food chain threat, a lethal threat, a direct non-lethal toxicant, indirect toxicant, or some combination of the four. Chemical residue studies are appropriate if the contaminant of concern (COC) will bioaccumulate. Ecotoxicological information can provide insight about contaminants that are expected to accumulate in organisms. It can also provide information about which organisms provide the best data for the study objectives. For example, the species-specific bioaccumulation rate must be considered along with analytical detection limits; the bioaccumulated levels need to be above the analytical detection limits. In contrast, population/ community studies or toxicity testing may be more appropriate if the contaminants cause direct lethality.

2.2.3.3 Exposure - Response Relationships

The relationship between the exposure (or dose) of a contaminant and the response that it elicits is a fundamental concept in toxicology (Timbrell 1989). The simplest response to observe is death. Some examples of other responses that vary in terms of ease of measurement include pathological lesions, cell necrosis, biochemical changes, and behavioral changes. It is this foundation of exposure-response relationships upon which the concept of chemical residue studies, population/community studies, and toxicity testing/bioassays are built upon.

2.2.3.4 Chemical Residue Studies

Residue studies are appropriate to use when there is concern about the accumulation of contaminants in the tissues of indigenous species. Residue studies are conducted by collecting organisms of one or more species and comparing the contaminant bioaccumulation data to those organisms collected from a reference area.

Chemical residue studies require field collection of biota and subsequent tissue analysis. A representative organism for collection and analysis is selected based on the study objectives and the site habitat. Generally the

organism should be abundant, sessile (or with limited home range), and easy to capture. These attributes help to provide a sufficient number of samples for analysis thereby strengthening the linkage to the site. A number of organism- and contaminant-specific factors should also be considered when designing residue studies (see Philips [1977] and [1978] for additional information). The subsequent chemical analysis may be conducted on specific target tissues or the whole body. In most cases, whole-body analysis is the method of choice to support biological assessments. This is because most prey species are eaten in entirety by the predator.

In designing residue analysis studies, it is important to evaluate the exposure pathway carefully. If the organisms analyzed are not within the site-specific exposure pathway, the information generated will not relate to the environmental threat. Evaluation of the exposure pathway may suggest that a species other than the one of direct concern might provide a better evaluation of potential threat or bioaccumulation.

Because there are different data needs for each objective, the study objective needs to be determined prior to the collection of organisms. In these studies the actual accumulation (dependent upon the bioavailability) of the contaminants is evaluated rather than assumed from literature values. The information collected then allows for site-specific evaluation of the threat and reduces the uncertainty associated with the use of literature bioavailability values. These factors may be applied for specific areas of uncertainty inherent from the extrapolation of available data (e.g., assumptions of 100 percent bioaccumulation, variations in sensitive populations).

As stated previously, because site conditions as well as the bioavailability can change over time, it is important that exposure medium (soil, sediment, or water) samples and biological samples are collected simultaneously and analyzed for the same parameters to allow for the comparison of environmental contaminant levels in the tissue and the exposure medium. This is critical in establishing a site-specific linkage that must be determined on a case-by-case basis.

2.2.3.5 Population/Community Response Studies

The fundamental approach to population or community response studies is to systematically sample an area, documenting the organisms of the population or community. Individuals are typically identified and enumerated, and calculations are made with respect to the number, and species present. These calculated values (e.g., indices or metrics) are used to compare sampling locations and reference conditions. Some population and community metrics include the number of individuals, species composition, density, diversity, and community structure.

2.2.3.6 Toxicity Testing/Bioassays

A third common assessment approach is to utilize toxicity tests or bioassays. A toxicity test may be designed to measure the effects from acute (short-term) or chronic (long-term) exposure to a contaminant. An acute test attempts to expose the organism to a stimulus that is severe enough to produce a response rapidly. The duration of an acute toxicity test is short relative to the organism's life cycle and mortality is the most common response measured. In contrast, a chronic test attempts to induce a biological response of relatively slow progress through continuous, long-term exposure to a contaminant.

In designing a toxicity test, it is critical to understand the fate, transport, and mechanisms of toxicity of the contaminants to select the test type and conditions. The toxicity test must be selected to match the site and its conditions rather than modify the site matrix for the use of a particular test. Factors to consider are the test species, physical/chemical factors of the contaminated media, acclimation of test organisms, necessity for laboratory versus field testing, test duration, and selection of test endpoints (e.g., mortality or growth). A thorough understanding of the interaction of these and other factors is necessary to determine if a toxicity test meets the study objectives.

The selection of the best toxicity test, including the choice of test organism, depends on several factors:

- The decisions that will be based on the results of the study
- The ecological setting of the site
- The contaminant(s) of concern

Toxicity testing can be conducted on a variety of sample

matrices, including water (or an aqueous effluent), sediment, and soil. Soil and sediment toxicity tests can be conducted on the parent material (solid-phase tests) or on the elutriate (a water extract of the soil or sediment). Solid-phase sediment and soil tests are currently the preferred tests since they evaluate the toxicity of the matrix of interest to the test organisms, thereby providing more of a realistic site-specific exposure scenario.

As stated previously, one of the most frequently used endpoints in acute toxicity testing is mortality (also referred to as lethality) because it is one of the most easily measured parameters.

In contrast, some contaminants do not cause mortality in test organisms but rather they affect the rate or success of reproduction or growth in test organisms. In this case, the environmental effect of a contaminant may be that it causes reproductive failure but does not cause mortality in the existing population. In either case, the population will either be eliminated or drastically reduced.

The use of control as well as reference groups is normally required. Laboratory toxicity tests include a control that evaluates the laboratory conditions, and the health and response of the test organisms. Laboratory controls are required for all valid toxicity tests. A reference provides information on how the test organisms respond to the exposure medium without the site contaminants. Therefore, the reference is necessary for interpretation of the test results in the context of the site (i.e., sample data is compared to the reference data). It is not uncommon for conditions other than contamination to induce a response in a toxicity test. With proper reference and control tests, toxicity tests can be used to establish a link between contaminants results and adverse effects.

Within the Superfund Program, conducting toxicity tests typically involves collecting field samples (water, sediment, soil) and transferring the materials to a laboratory. *In situ* (field conducted) tests can be run if field conditions permit. There are benefits and limitations associated with each approach. The most notable benefit of laboratory testing is that exposure conditions are controlled, but this leads to its most notable limitation, a reduction of realism. With *in situ* tests, the reality of the exposure situation is increased, but there is a reduction of test controls. See U.S. EPA's *Compendium of ERT Toxicity Testing Procedures*, OSWER Directive 9360.4-08, EPA/540/P-91/009 (U.S. EPA 1991a), for descriptions of nine common toxicity tests and *Standard Guide for Conducting Sediment Toxicity Tests with Freshwater Invertebrates*, ASTM Standard E1383, October 1990.

Species Selection for Toxicity Testing

Selection of the test organism is critical in designing a study using toxicity testing. The species selected should be representative relative to the assessment endpoint, typically an organism found within the exposure pathway expected in the field. To be useful in evaluating risk, the test organism must respond to the contaminant(s) of concern. This can be difficult to achieve since the species and tests available are limited. Difficult choices and balancing of factors are frequently necessary.

3.0 BIOLOGICAL SAMPLING METHODS

Once a decision has been made that additional data are required to assess the biological threat posed by a site, an appropriate sampling plan must be developed. The selection of ecological sampling methods and equipment is dependent upon the field assessment approach, as discussed in Chapters 1 and 2. Thus, the selection of an assessment approach is the initial step in the collection process. This chapter does not present step-by-step instructions for a particular method, nor does it present an exhaustive list of methods or equipment. Rather, it presents specific examples of the most commonly used methods and associated equipment. Table 4.1 (at the end of this chapter) lists some of the standard operating procedures (SOPs) used by the U.S. EPA's Environmental Response Team Center (ERTC).

Because of the complex process required for selecting the proper assessment approach for a particular site, consultation with an ecologist/biologist experienced in conducting ecological risk assessments is strongly recommended.

3.1 CHEMICAL RESIDUE STUDIES

Chemical residue studies are a commonly used approach that can address the bioavailability of contaminants in media (e.g., soil, sediment, water). They are often called tissue residue studies because they measure the contaminant body burden in site organisms.

When collecting organisms for tissue analyses, it is critical that the measured levels of contaminants in the organism are attributable to a particular location and contaminant level within the site. Collection techniques must be evaluated for their potential to bias the generated data. Collection methods can result in some form of biased data either by the size, sex, or individual health of the organism. Collection techniques are chosen based on the habitat present and the species of interest. When representative approaches are not practical, the potential bias must be identified and considered when drawing conclusions from the data. The use of a particular collection technique should not be confused with the need to target a "class" of individuals within a population for collection. For example, in a specific study it may be desirable to collect only males of the species or to collect fish of consumable size.

Some receptors of concern (ROCs) cannot be collected and analyzed directly because of low numbers of individuals in the study area, or other technical or logistical reasons. Exposure levels for these receptors can be estimated by collecting organisms that are preyed upon by the ROC. For example, if the ROC is a predatory bird, the species collected for contaminant level measurements may be one of several small mammals or fish that the ROC is known to eat.

As noted previously, it is critical to link the accumulated contaminants both to the site and to an exposure medium. Subsequently, the collection and analysis of representative soil, sediment, or water samples from the same location are critical. A realistic site-specific Bioaccumulation Factor (BAF) or Bioconcentration Factor (BCF) may then be calculated for use in the site exposure models.

"Bioconcentration is usually considered to be that process by which toxic substances enter aquatic organisms, by gill or epithelial tissue from the water. Bioaccumulation is a broader term in the sense that it usually includes not only bioconcentration but also any uptake of toxic substances through the consumption of one organism." (Brungs and Mount 1978).

3.1.1 Collection Methods

It should be noted that any applicable state permits should be acquired before any biological sampling event. States requirements on organism, method, sampling location, and data usage differ widely and may change from year to year.

The techniques used to collect different organisms are specific to the study objectives. All techniques are selective to some extent for certain species, sizes, habitat, or sexes of animals. Therefore, the potential biases associated with each technique should be determined prior to the study. If the biases are recognized prior to collection, the sampling may be designed to minimize effect of the bias. For example, large traps are not effective for trapping small animals since small mammals are not heavy enough to trigger the trap or may escape through minute trap openings.

In determining environmental threat, the target species generally consist of prey species such as earthworms, small mammals, or fish. Residue data from these organisms can be used to evaluate the risk to higher trophic level organisms, which may be difficult to capture or analyze.

3.1.1.1 Comparability Considerations

There are two issues that directly affect field collection. First, organisms such as benthic macroinvertebrates tend to have a patchy or non-uniform distribution in the environment due to micro habitats and other factors. Therefore, professional evaluation in matching habitat for sampling is critical in the collection of a truly representative sample of the community. Second, variability in sampling effort and effectiveness needs to be considered.

3.1.1.2 Mammals

Trapping is the most common method for the collection of mammals. The selection of traps is determined by the species targeted and the habitat present. Both live trap or kill trap methods may be acceptable for residue studies, but consideration of other data uses (e.g., histopathology) or concern for injury or death of non-target species can influence the use of certain trap types.

Several trap methods are available for collecting small mammals. Commonly used traps include Museum Special, Havahart, Longworth, and Sherman traps (Figure 3). Although somewhat labor-intensive, pitfall trap arrays may also be established to include mammals that are not regularly trapped using other techniques (e.g., shrews).

Trap placement is a key element when collecting samples. Various methods of trap placement can be utilized. These include, but are not limited to:

- Sign method/Best set method
- Paceline method
- Grid method

When using the sign/best set method, an experienced field technical specialist searches for fresh mammal signs (e.g., tracks, scat, feeding debris) to determine where the trap should be positioned. This method typically produces higher trapping success than other methods, however, this method is biased and is therefore generally

used to determine what species are present at the site.

The paceline method involves placement of traps at regular intervals along a transect. A starting point is selected and marked, a landmark is identified to indicate the direction of the transect, and as the field member walks the transect, the traps are placed at regular intervals along it.

The grid method is similar to the paceline method but involves a group of evenly spaced parallel transects of equal lengths to create a grid. Traps are placed at each grid node. The size of the grid is dependent on the species to be captured and the type of study. Grids of between 500 to 1,000 square meters containing approximately 100 traps are common. If a grid is established in a forest interior, additional parallel trapping lines may be established to cover the edge habitat.

Regardless of the type of trapping used, habitat disturbance should be kept to a minimum to achieve maximum trapping success. In most areas, a trapping success of 10 percent is considered maximum but is oftentimes significantly lower (e.g., 2 to 5 percent). Part of this reduced trapping success is due to habitat disturbance. Therefore, abiotic media samples (e.g., soil, sediment, water) should be collected well in advance of trapping efforts or after all trapping is completed. Trapping success also varies with time but may increase over time with diminishing returns. In other words, extending the trapping period over several days may produce higher trapping success by allowing mammals that were once peripheral to the trapping area to immigrate into the now mammal-depauperate area. These immigrants would not be representative of the trapping area. Therefore, a trapping period of 3 days is typically used to minimize this situation.

Trapping success will also vary widely based on the available habitat, targeted species, season, and geographical location of the site. When determining trap success objectives, it is important to keep in mind the minimum sample mass/volume requirements for chemical residue studies.

3.1.1.3 Fish

Electrofishing, gill nets, trawl nets, seine nets, and minnow traps are common methods used for the collection of fish. The selection of which technique to use is dependent on the species targeted for collection and the system being sampled. In addition, there are other available fish netting and trapping techniques that may be more appropriate in specific areas. As with mammal trapping, disturbance in the area being sampled should be kept to a minimum to ensure collection success.

Electrofishing uses electrical currents to gather, slow down, or immobilize fish for capture. An electrical field is created between and around two submerged electrodes that stuns the fish or alters their swimming within or around the field. Depending on the electrical voltage, the electrical pulse frequency, and the fish species, the fish may swim towards one of the electrodes, swim slowly enough to capture, or may be stunned to the point of immobilization. This technique is most effective on fish with swimbladders and/or shallow water since these fish will float to the surface for easy capture.

Electrofishing can be done using a backpack-mounted electroshocker unit, a shore-based unit, or from a boat using either type. Electrofishing does not work in saline waters and can be ineffective in very soft water. Electrofishing is less effective in deep water where the fish can avoid the current. In turbid waters, it may be difficult to see the stunned fish.

Gill netting is a highly effective passive collection technique for a wide range of habitats. Because of its low visibility under water, a gill net captures fish by entangling their gill plates as they attempt to swim through the area in which the gill net has been placed in. Unfortunately, this may result in fish to be injured or killed due to further entanglement, predation, or fatigue.

The size and shape of fish captured is relative to the size and kind of mesh used in the net thus creating bias towards a certain sized fish. These nets are typically used in shallow waters, but may extend to depths exceeding 50 meters. The sampling area should be free of obstructions and floating debris, and provide little to no current. (Hurbert 1983)

Otter trawl netting is an active collection technique that utilizes the motion of a powered boat to drag a pocket-shaped net through a body of water. The net is secured to the rear of a boat and pulled to gather any organisms that are within the opening of the pocket. This pocket is kept open through the use of underwater plates on either side of the net that act as keels, spreading the mouth of the net open.

Seining is another active netting technique that traps fish by encircling them with a long wall of netting. The top of the net is buoyed by floats and the bottom of the net is weighed down by lead weights or chains. Seine nets are effective in open or shallow waters with unobstructed bottoms. Beach or haul seines are used in shallow water situations where the net extends to the bottom. Purse seines are designed for applications in open water and do not touch the bottom (Hayes 1983).

The use of minnow traps is a passive collection technique for minnow-sized fish. The trap itself is a metal or plastic cage that is secured to a stationary point and baited to attract fish. Small funnel-shaped openings on either end of the trap allow fish to swim easily into it, but are difficult to locate for exit. Cage "extenders" or "spacers" that are inserted to lengthen the cage, allow larger organisms such as eels, or for a larger mass of fish to be collected.

3.1.1.4 Vegetation

Under certain conditions, the analysis of the chemical residue in plants may be a highly effective method of assessing the impacts of a site. The bioaccumulative potential of plants varies greatly however, among contaminants, contaminant species, soil/sediment texture and chemistry, plant condition, and genetic composition of the plant. In addition to this variability, plants can translocate specific contaminants to different parts of the plant. For example, one contaminant may tend to accumulate in the roots of a plant, whereas a second contaminant may tend to accumulate in the fruit of the same plant. In this scenario, the collection and analysis of a plant part that normally does not receive translocated materials would not result in a useful sample. Therefore, it is crucial to conduct a literature review prior to establishing a sampling protocol.

Sampling of herbaceous plants should be conducted during the growing season of the species of interest.

Sampling of woody plants may be conducted during the growing or dormant season, however, most plants translocate materials from the aboveground portions of the plant to the roots prior to dormancy.

Collection methods and sampling specifics may be found in U.S. EPA/ERT SOP #2037, *Terrestrial Plant Community Sampling*; others are provided in Table 4.1.

3.1.2 Sample Handling and Preparation

The animals or plants collected should be identified to species level or the lowest practical taxonomic level. Appropriate metrics (e.g., weight, animal body length, plant height) and the presence of any external anomalies, parasites, and external pathologies should be recorded. If compositing of the sample material is necessary, it should be performed in accordance with the study design.

Depending upon the study objectives, it may be necessary to isolate the contaminant levels in animal tissue from the contaminant levels in the food or abiotic matrices (e.g., sediment) entrained in the digestive tract of the organism. This is an important process in that it separates the contribution of two distinct sources of contaminants to the next trophic level, thereby allowing the data user to recognize the relative importance of the two sources.

Clearing of the digestive tract (i.e., depuration) of the organism must then be accomplished prior to the chemical analysis. The specific depuration procedures will vary with each type of organism but all involve allowing the organism to excrete waste products in a manner in which the products may not be reingested, absorbed, or deposited back onto the organism.

Biological samples should be handled with caution to avoid personal injury, exposure to disease, parasites, or sample contamination. Personal protection such as gloves should be worn when handling animals and traps to reduce the transfer of scents or oils from the hand to the trap, which could cause an avoidance reaction in the targeted animals.

Samples collected for biological evaluation must be treated in the same manner as abiotic samples (i.e., the same health and safety guidelines, decontamination protocols, and procedures for preventing cross-

contamination must be adhered to). Biological samples do require some extra caution in handling to avoid personal injury and exposure to disease, parasites, and venoms/resins. The selection of sample containers and storage conditions (e.g., wet ice) should follow the same protocols as abiotic samples. Refer to Chapter 4.0 for determination of holding times and additional quality assurance/quality control (QA/QC) handling procedures.

3.1.3 Analytical Methods

Chemical analytical methods for tissue analysis are similar to those for abiotic matrices (e.g., soil and water), however, the required sample preparation procedures (e.g., homogenization and subsampling) of biological samples are frequently problematic. For example, large bones, abundant hair, or high cellulose fiber content may result in difficult homogenization of mammals and plants. Extra steps may be required during sample cleanup due to high lipid (fat) levels in animals tissue or high resin content in plant tissue.

Most tissue samples can be placed in a laboratory blender with dry ice and homogenized at high speeds. The sample material is then left to sit to allow for the sublimation of the dry ice. Aliquots of the homogenate may then be removed for the required analyses.

The requirement for split samples or other QA samples must be determined prior to sampling to ensure a sufficient volume of sample is collected. Chapter 4.0 discusses the selection and use of QA/QC samples.

The detection limits of the analytical parameters should be established prior to the collection of samples. Detection limits are selected based on the level of analytical resolution that is needed to interpret the data against the study objectives. For example, if the detection limit for a compound is 10 mg/kg but the concentration in tissue which causes effects is 1 mg/kg, the detection limit is not adequate to determine if a problem exists. It should be noted that standard laboratory detection limits for abiotic matrices are often not adequate for tissue samples. Chapter 4.0 provides details on detection limits and other QA/QC parameters.

The tissue analysis can consist of whole body residue analysis or analysis of specific tissues (i.e., fish filets). Although less frequently used in Superfund, tissues such as organs (e.g., kidney or liver) may be analyzed. The

study endpoints will determine whether whole body, fillet, or specific organ samples are to be analyzed.

Concurrent analyses should include a determination of percent lipids and percent moisture. Percent lipids may be used to normalize the concentration of non-polar organic contaminant data. In addition, the lipid content of the organisms analyzed can be used to evaluate the organism's health. Percent moisture determinations allow the expression of contaminant levels on the basis of wet or dry weight. Wet weight concentration data are frequently used in food chain accumulation models, and dry weight basis data are frequently reported between sample location comparisons.

Histopathological Analysis

Histopathological analysis can be an effective mechanism for establishing causative relationships due to contaminants since some contaminants can cause distinct pathological effects. For example, cadmium causes visible kidney damage providing causal links between contaminants and effects. These analyses may be performed on organisms collected for residue analysis. A partial necropsy performed on the animal tissue may indicate the presence of internal abnormalities or parasites. The time frame and objectives of the study determine if histopathological analysis is warranted.

3.2 POPULATION/COMMUNITY RESPONSE STUDIES

Population/community response studies are a commonly utilized field assessment approach. The decision to conduct a population/community response study is based on the type(s) of contaminants, the time available to conduct the study, the type of communities potentially present at the site, and the time of year of the study. These studies are most commonly conducted on non-time-critical or long-term remediation-type site activities. During limited time frame responses, however, a population/community survey or screening level study may be useful for providing information about potential impacts associated with a site.

3.2.1 Terrestrial Vertebrate Surveys

Methods for determining adverse effects on terrestrial vertebrate communities are as follows: censusing or population estimates, sex-age ratio determinations,

natality/mortality estimations, and diversity studies.

True or accurate censuses are usually not feasible for most terrestrial vertebrate populations due to logistical difficulties. Estimations can be derived by counting a subset of organisms or counting and evaluating signs such as burrows, nests, tracks, feces, and carcasses. Capture-recapture studies may be used to estimate population size but are labor-intensive and usually require multiple-season sampling. If conducted improperly, methods for marking captured organisms may cause irritation or injury or interfere with the species' normal activities.

Age ratios provide information on natality and rearing success, age-specific reproductive rates, and mortality and survival rates. Sex ratios indicate whether sexes are present in sufficient numbers and proportions for normal reproductive activity.

Community composition (or diversity) can be assessed by species frequency, species per unit area, spatial distribution of individuals, and numerical abundance of species (Hair 1980).

3.2.2 Benthic Macroinvertebrate Surveys

Benthic macroinvertebrate (BMI) population/community evaluations in small- to medium- sized streams have been successfully used for approximately 100 years to document injury to the aquatic systems. There are many advantages to using BMI populations to determine the potential ecological impact associated with a site. Sampling is relatively easy, and equipment requirements are minimal. An evaluation of the community structure may be used to assess overall water quality, evaluate the integrity of watersheds, or suggest the presence of an influence of the community structure that is independent of water quality and habitat conditions.

Because BMIs are a primary food source for many fish and other organisms, threats beyond the benthic community can be inferred from the evaluation of BMIs. Techniques such as rapid bioassessment protocols may be used as a tool to support this type of finding and inference. A more comprehensive discussion of general benthological surveys may be found in U.S. EPA (1990).

3.2.2.1 Rapid Bioassessment Protocols for Benthic Communities

Rapid bioassessment protocols are an inexpensive screening tool used for determining if a stream is supporting or not supporting a designated aquatic life use. The rapid bioassessment protocols advocate an integrated assessment, comparing habitat and biological measures with empirically defined reference conditions (U.S. EPA 1989a).

The three major components of a rapid bioassessment essential for determining ecological impact are:

- Biological survey
- Habitat assessment
- Physical and chemical measurements

As with all population/community evaluations, the habitat assessment is of particular concern with respect to representative sampling. Care must be taken to prevent bias during collection of the benthic community resulting from sampling dissimilar habitats. Similar habitats must be sampled to make valid comparisons between locations. In addition to habitat similarity, the sampling technique and level of effort at each location must be uniform to achieve an accurate interpretation of results.

In the U.S. EPA Rapid Bioassessment Protocol (RBP), various components of the community and habitat are evaluated, a numerical score is calculated, and the score is compared to predetermined values. A review of the scores, together with habitat assessment and the physical and chemical data, support a determination of impact. U.S. EPA Reference (May, 1989a) presents the calculation and interpretation of scores.

Standard protocols, including the RBP, have been developed to facilitate surveying BMIs to determine impact rapidly. These protocols use a standard approach to reduce the amount of time spent collecting and analyzing samples. Protocols range from a quick survey of the benthos (Protocol I) to a detailed laboratory classification analysis (Protocol III). Protocol I may be conducted in several hours; Protocol II is more intensive and focuses on major taxonomic levels; and Protocol III may require numerous hours to process each sample to a greater level of taxonomic and community assessment resolution. These protocols are used to determine community health and biological condition via tolerance

values and matrices. They also create and amend a historical data base that can be used for future site evaluation.

3.2.2.2 General Benthological Surveys

Benthological surveys can be conducted with methods other than those discussed in the RBP protocols utilizing techniques discussed in the literature. The overall concept is generally the same as that used in the RBP, but the specific sampling technique changes depending on the habitat or community sampled.

3.2.2.3 Reference Stations

The use of a reference station is essential to determine population/community effects attributable to a site. The use of a reference station within the study area is preferable (upstream or at a nearby location otherwise outside the area of site influence). In some cases this is not possible due to regional impacts, area-wide habitat degradation, or lack of a similar habitat. In these cases the use of population/community studies should be re-evaluated within the context of the site investigation. If the choice is made to include the population/community study, regional reference or a literature-based evaluation of the community may be options.

3.2.2.4 Equipment for Benthic Surveys

The selection of the most appropriate sampling equipment for a particular site is based primarily on the habitat being sampled. This subsection is a brief overview of the equipment available for the collection of BMIs. Detailed procedures are not discussed in this document. For additional information, refer to the SOPs and methods manuals provided in Table 4.1, or consult an ecologist/biologist experienced in this type of field collection.

Long-handled nets or a Surber sampler with a 0.5-millimeter (mm) size mesh are common sampling nets for the collection of macroinvertebrates from a riffle area of a stream. Samples to be collected from deep water gravel, sand, or soft bottom habitats such as ponds, lakes, or rivers are more often sampled using a small Ponar or Ekman dredge. Artificial substrates are used in varying habitats when habitat matching is problematic and/or native substrate sampling would not be effective. The most common types of artificial substrate samplers are

multiple-plate samplers or barbecue basket samplers.

The organisms to be taken to the laboratory for identification or retained for archival purposes may be placed in wide-mouthed plastic or glass jars (for ease in removing contents) and preserved in 70 percent 2-propanol (isopropyl alcohol) or ethyl alcohol (ethanol), 30 percent formalin, or Kahle's solution. Refer to methods manuals for detailed information on sample handling and preservation.

3.2.3 Fish Biosurveys

3.2.3.1 Rapid Bioassessment Protocols for Fish Biosurveys

RBPs IV and V are two levels of fish biosurvey analyses. Protocol IV consists of a questionnaire to be completed with the aid of local and state fisheries experts. Protocol V is a rigorous analysis of the fish community through careful species collection, identification, and enumeration. This level is comparable to the macroinvertebrate Protocol III (see Section 3.2.2.1) in effort. Detailed information on both protocols can be found in *Rapid Bioassessments Protocols for Use In Streams and Rivers* (U.S. EPA 1989a).

3.3 TOXICITY TESTS

Toxicity tests evaluate the relative threat of exposure to contaminated media (e.g., soil, sediment, water) in a controlled setting. These tests are most often conducted in the laboratory, although they may be conducted in the field as well. These tests provide an estimate of the relationship between the contaminated medium, the level of contaminant, and the severity of adverse effects under specific test parameters. Toxicity tests are categorized by several parameters which include duration of the test, test species, life stage of the organism, test end points, and other variables.

The collection of the actual samples on which the tests are to be conducted follow the same protocols as collection of representative samples for chemical analyses. Typically, a subsample of the media collected for toxicity testing is submitted for chemical analyses. The use of a concentration gradient for toxicity testing is frequently desired to establish a concentration gradient within the test. This also eliminates the need to sample all the locations at a site. The specific methods to be

followed for toxicity tests are described in detail in U.S. EPA's *Compendium of ERT Toxicity Testing Procedures*, OSWER Directive 9360.4-08, EPA/540/P-91-009 (U.S. EPA 1991a), as well as existing SOPs listed in Table 4.1. These published procedures address sample preservation, handling and storage, equipment and apparatus, reagents, test procedures, calculations, QA/QC, and data validation. The practical uses of various toxicity tests, including examples of acute and chronic tests, are described next. Each section includes an example toxicity test.

3.3.1 Examples Of Acute Toxicity Tests

Example No. 1 (solid-phase soil)

Laboratory-raised earthworms are placed 30 per replicate into test chambers containing site soil. A laboratory control and a site reference treatment are established to provide a means for comparison of the resulting data set. Depending on the anticipated contaminant concentrations in the site soil, the soil may be used in its entirety or diluted with control or site reference soil. The test chambers are examined daily for an exposure period of 14 days and the number dead organisms is tabulated. When the observed mortality in the site soil treatments is statistically compared to control and site reference treatments, inferences regarding the toxicity of the contaminant concentrations in the site soil treatments may be drawn.

Example No. 2 (surface water)

Fathead minnows (*Pimephales promelas*) are exposed for 96 hours in aerated test vessels containing surface water from sampling locations representing a concentration gradient. The mortality of the organisms is recorded at the end of the exposure period and statistically compared to control and site reference treatments. Statistically significant differences between treatments may be attributed to the varying contaminant concentrations.

3.3.2 Examples of Chronic Toxicity Tests

Example No. 1 (surface water)

Fathead minnow larvae (*Pimephales promelas*) are exposed for 7 days to surface water collected from sampling locations that represent a concentration gradient. Each replicate consists of 20 individuals of the same maturity level. The test vessels are aerated and the water is replaced daily. The fish, which should have remained alive throughout the exposure period, are harvested and measured for body length and body weight. These results represent growth rates and are statistically compared to the control and site reference treatments to infer the toxicological effects of the contaminant concentrations.

Example No. 2 (sediment)

Midge (*Chironomus* sp.) larvae are exposed for 10 days to sediment, overlain with site reference water, and collected from sampling locations that represent a concentration gradient. Each replicate consists of 200 individuals of the same maturity level (1st instar). The test vessels are aerated and the water is replaced daily. At the end of the exposure period, the larvae are removed from the test vessels and measured for body length and body weight.

The organisms are then returned to the test vessels and allowed to mature to the adult stage. An emergence trap is placed over the test vessel and the number of emerging adults is recorded. These results, as well as the length and weight results, are statistically compared to the control and site reference treatments to infer the toxicological effects of the contaminant concentrations.

Figure 2: Common Mammal Traps

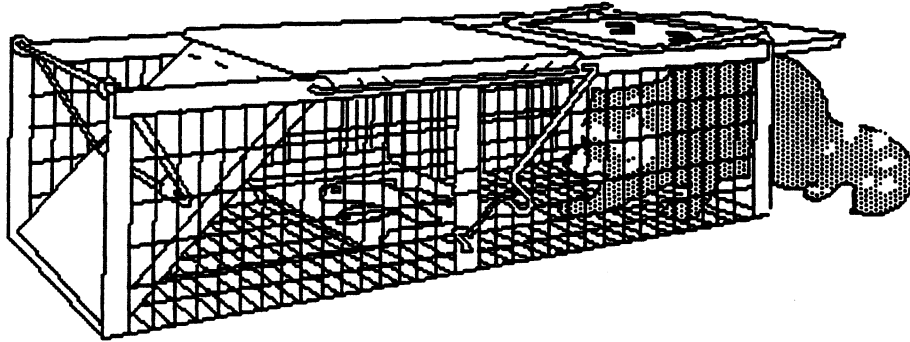

Havahart Trap

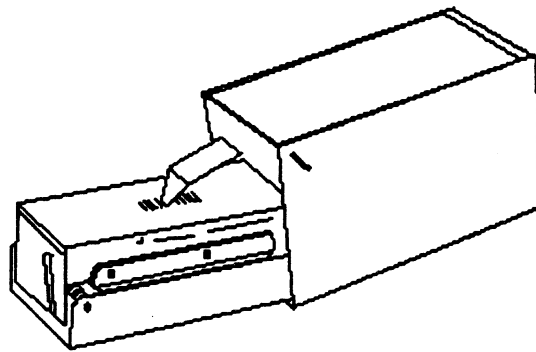

Longworth live trap

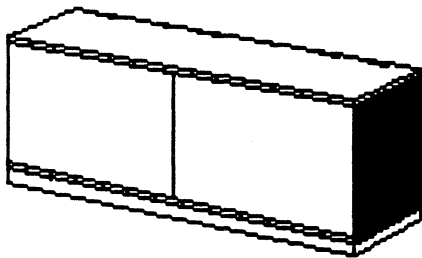

(A)

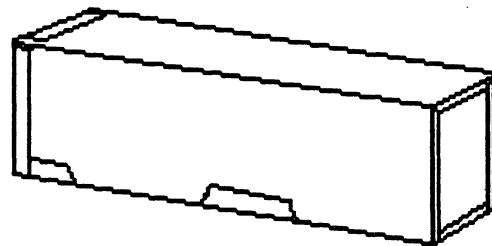

(B)

Folding (A) and non-folding (B) Sherman live traps

TABLE I
Reference List of Standard Operating Procedures -- Ecological Sampling Methods

SOP/Method No.	Source	Procedure/Method Title	Publication No.
SOP No. 1820	ERTC	Tissue Homogenization Procedure	(in development)
SOP No. 1821	ERTC	Semi-Volatiles Analysis of Tissue Samples by GC/MS	(in development)
SOP No. 1822	ERTC	Pesticides/PCB Analysis of Tissue Samples by GC/ECD	(in development)
SOP No. 1823	ERTC	Microwave Digestion and Metals Analysis of Tissue Samples	(in development)
SOP No. 2020	ERTC	7-Day Standard Reference Toxicity Test Using Larval Fathead Minnows <i>Pimephales promelas</i>	OSWER EPA/540/P-91/009
SOP No. 2021	ERTC	24-Hour Range Finding Test Using <i>Daphnia magna</i> or <i>Daphnia pulex</i>	OSWER EPA/540/P-91/009
SOP No. 2022	ERTC	96-Hour Acute Toxicity Test Using Larval <i>Pimephales promelas</i>	OSWER EPA/540/P-91/009
SOP No. 2023	ERTC	24-Hour Range Finding Test Using Larval <i>Pimephales promelas</i>	OSWER EPA/540/P-91/009
SOP No. 2024	ERTC	48-Hour Acute Toxicity Test Using <i>Daphnia magna</i> or <i>Daphnia pulex</i>	OSWER EPA/540/P-91/009
SOP No. 2025	ERTC	7-Day Renewal Toxicity Test Using <i>Ceriodaphnia dubia</i>	OSWER EPA/540/P-91/009
SOP No. 2026	ERTC	7-Day Static Toxicity Test Using Larval <i>Pimephales promelas</i>	OSWER EPA/540/P-91/009
SOP No. 2027	ERTC	96-Hour Static Toxicity Test Using <i>Selenastrum capricornutum</i>	OSWER EPA/540/P-91/009
SOP No. 2028	ERTC	10-Day Chronic Toxicity Test Using <i>Daphnia magna</i> or <i>Daphnia pulex</i>	OSWER EPA/540/P-91/009
SOP No. I-001	ERTC	15-Day Solid Phase Toxicity Test Using <i>Chironomus tentans</i>	(in development)
SOP No. I-002	ERTC	28-Day Solid Phase Toxicity Test Using <i>Hyaella azteca</i>	(in development)
Greene et al.(1989)	-	14-Day Acute Toxicity Test Using adult <i>Eisenia andrei</i> (earthworms)	EPA 600/3-88-029
SOP No. I-005	ERTC	Field Processing of Fish	(in development)
SOP No. 2029	ERTC	Small Mammal Sampling and Processing	(in development)
SOP No. 2032	ERTC	Benthic Sampling	(in development)
SOP No. 2033	ERTC	Plant Protein Determination	(in development)
SOP No. 2034	ERTC	Plant Biomass Determination	(in development)
SOP No. 2035	ERTC	Plant Peroxidase Activity Determination	(in development)
SOP No. 2036	ERTC	Tree Coring and Interpretation	(in development)
SOP No. 2037	ERTC	Terrestrial Plant Community Sampling	(in development)

4.0 QUALITY ASSURANCE/QUALITY CONTROL

4.1 INTRODUCTION

The goal of representative sampling is to yield quantitative data that accurately depict site conditions in a given period of time. QA/QC measures specified in the sampling procedures minimize and quantify the error introduced into the data.

Many QA/QC measures are dependant on QA/QC samples submitted with regular field samples. QA/QC samples evaluate the three following types of information: (1) the degree of site variation; (2) whether samples were cross-contaminated during sampling and sample handling procedures; and (3) whether a discrepancy in sample results is attributable to field handling, laboratory handling, or analysis. For additional information on QA objectives, refer to U.S. EPA *Quality Assurance/Quality Control (QA/QC) Guidance for Removal Activities*, EPA/540/G-90/004, April 1990.

4.2 DATA CATEGORIES

The U.S. EPA has established a process of data quality objectives (DQOs) which establish what type, quantity, and quality of environmental data are appropriate for their intended application. In its DQO process, U.S. EPA has defined two broad categories of data: screening and definitive.

Screening data are generated by rapid, less precise methods of analysis with less rigorous sample preparation. Sample preparation steps may be restricted to simple procedures such as dilution with a solvent, rather than an elaborate extraction/digestion and cleanup. At least 10 percent of the screening data are confirmed using the analytical methods and QA/QC procedures and criteria associated with definitive data. Screening data without associated confirmation data are not considered to be data of known quality. To be acceptable, screening data must include the following:

- chain of custody
- initial and continuing calibration
- analyte identification
- analyte quantification

Streamlined QC requirements are the defining characteristic of screening data.

Definitive data are generated using rigorous analytical methods (e.g., approved U.S. EPA reference methods). These data are analyte-specific, with confirmation of analyte identity and concentration. Methods produce tangible raw data (e.g., chromatograms, spectra, digital values) in the form of hard-copy printouts or computer-generated electronic files. Data may be generated at the site or at an off-site location as long as the QA/QC requirements are satisfied. For the data to be definitive, either analytical or total measurement error must be determined. QC measures for definitive data contain all the elements associated with screening data, but also include trip, method, and rinsate blanks; matrix spikes; performance evaluation samples; and replicate analyses for error determination.

For more details on these data categories, refer to U.S. EPA *Data Quality Objectives Process For Superfund*, EPA/540/R-93/071, Sept 1993.

4.3 SOURCES OF ERROR

The four most common potential sources of data error in biological sampling:

- Sampling design
- Sampling methodology
- Sample heterogeneity
- Sample analysis

4.3.1 Sampling Design

The initial selection of a habitat is a potential source of bias in biological sampling, which might either exaggerate or mask the effects of hazardous substances in the environment. In a representative sampling scheme, habitat characteristics such as plant and animal species composition, substrates, and degree of shading should be similar at all locations, including the reference location. The same individual should select both the test site and the control and background site to minimize error in comparing site conditions.

Standardized procedures for habitat assessment and selection also help minimize design error. The selection of an inappropriate species may introduce an error into the representative sampling design. This error can be minimized by selecting a species that is representative of the habitat and whose life-cycle is compatible with the timing of the study. In addition, migratory or transient species should be avoided.

4.3.2 Sampling Methodology

Sampling methodology and sample handling procedures may contain possible sources of error such as unclean sample containers, improper sample handling, and improper shipment procedures. Procedures for sample collection and handling should be standardized to allow easier identification of potential error. Follow SOPs or established procedures to ensure that all sampling techniques are performed consistently despite different sampling teams, dates, or locations. Use QA/QC samples (Section 4.4) to evaluate errors due to improper sampling methodology and sample handling procedures. These guidelines should apply to biological as well as soil, sediment, and water sampling.

During fishing operations, the sampling crew can prevent habitat disturbance by staying out of the water body near the sampling locations. The use of any particular technique may introduce judgment error into the sampling regimen if done improperly. For all techniques, sampling should be conducted from the downstream location to the upstream location to avoid contamination of the upstream stations. Data comparability is maintained by using similar collection methods and sampling efforts at all stations.

Rapid bioassessments in the field should include two QA/QC procedures: 1) collection of replicate samples at stations to check on the accuracy of the collection effort, and 2) repeat a portion (typically 10%) recount and reidentification for accuracy.

For tissue analyses, tools and other sampling equipment should be dedicated to each sample, or must be decontaminated between uses. To avoid contamination, sample containers must be compatible with the intended tissue matrix and analysis.

4.3.3 Sample Heterogeneity

Tissues destined for chemical analysis should be homogenized. Ideally, tissue sample homogenates should consist of organisms of the same species, sex, and development stage and size since these variables all affect chemical uptake. There is no universal SOP for tissue homogenization; specific procedures depend on the size and type of the organism. For example, tissues must be cut from fur and shell-bearing organisms as they cannot be practically homogenized as a whole. Homogenization procedures may vary by site objective. Tissue homogenates should be stored away from light and kept frozen at -20° C. Tissue homogenates are prepared in the laboratory and could be subject to cross-contamination.

Refer to U.S. EPA/ERT SOP #1820, *Tissue Homogenization Procedures* for further details on tissue homogenization procedures.

4.3.4 Sample Analysis

Analytical procedures may introduce errors from laboratory cross-contamination, extraction difficulties, and inappropriate methodology. Fats naturally present in tissues may interfere with sample analysis or extraction and elevate detection limits. Detection limits in the tissue samples must be the same as in the background tissue samples if a meaningful comparison is to be made. To minimize this interference, select an extraction or digestion procedure applicable to tissue samples.

Because many compounds (e.g., chlorinated hydrocarbons) concentrate in fatty tissues, a percent lipid analysis is necessary to normalize results among samples. Lipid recoveries vary among different analytical methods; percent lipid results for samples to be normalized and compared must be generated by the same analytical method. Select a lipid analysis based on the objective of the study (see references Herbes and Allen [1983] and Bligh and Dyer 1959). Sample results may be normalized on a wet-weight basis. If sample results are to be reported on a dry-weight basis, instruct the analytical laboratory to report the percent moisture content for each sample.

Appropriate sample preservation prevents loss of compounds and decomposition of tissues before analysis. Consult the appropriate SOP, analytical method, or designated laboratory contact to confirm holding times for tissue samples.

Tissue samples destined for sorting and identification (e.g., benthic macroinvertebrates, voucher fish) should be preserved in isopropyl or ethyl alcohol, formalin, or Kahle's solution. Preservation in these solvents precludes any chemical analysis.

4.4 QA/QC SAMPLES

QA/QC samples are collected at the site as prepared by the laboratory. Analysis of the QA/QC samples provides information on the variability and usability of biological sampling data, indicates possible field sampling or laboratory error, and provides a basis for future validation and usability of the analytical data. The most common field QA/QC samples are field replicates, reference, and rinsate blank samples. The most common laboratory QA/QC samples are performance evaluation (PE), matrix spike (MS), and matrix spike duplicate (MSD) samples. QA/QC results may suggest the need for modifying sample collection, preparation, handling, or analytical procedures if the resultant data do not meet site-specific quality assurance objectives.

Refer to data validation procedures in *U.S. EPA Quality Assurance/Quality Control (QA/QC) Guidance for Removal Activities*, EPA/540/G-90/004, April 1990, for guidelines on utilizing QA/QC samples.

4.4.1 Replicate Samples

Field Replicates

Field replicates for solid media are samples obtained from one sampling point that are homogenized, divided into separate containers, and treated as separate samples throughout the remaining sample handling and analytical processes. Field replicates for aqueous samples are samples obtained from one location that are homogenized and divided into separate containers. There are no "true" field replicates for biological samples, however, biological samples collected from the same station are typically referred to as replicates. In this case, the biological replicates are used to determine the variability associated with heterogeneity within a biological population. Field replicates may be sent to two or more laboratories or to the same laboratory as unique samples.

Field replicates may be used to determine total error for critical samples with contaminant concentrations near the level that determines environmental impact. To

determine error, a minimum of eight replicate samples is recommended for valid statistical analysis. For total error determination, samples should be analyzed by the same laboratory. The higher detection limit associated with composite samples may limit the usefulness of error determination.

NOTE: A replicate biological sample may consist of more than a single organism in those cases where the species mass is less than the mass required by the analytical procedure to attain required detection limits. This variability in replicate biological samples is independent of the variability in analytical procedures.

Toxicity Testing Replicates

For sediment samples, at least 3 replicate treatments should be conducted to determine variability between tests. The function of these replicates is to determine the variability of the test organism population within each treatment. This assumes the sample matrix exhibits a uniform concentration of the contaminants of concern within each treatment. Large variability may indicate a problem with the test procedures or organisms or lack of contaminant homogeneity within the sample matrix.

Site-Specific Examples of the Use of Replicates

Example No. 1

Two contaminant sources were identified at an active copper smelting facility. The first area was a slag pile containing high levels of copper suspected of migrating into the surrounding surface runoff pathways, subsequently leaching into the surface water of a surrounding stream system. The second area was the contaminated creek sediment that was present in the drainage pathway of the slag pile.

Whole-phase sediment toxicity tests were selected to evaluate the toxicity associated with the copper levels in the stream sediments. Sediment was collected at each sampling location (six locations total) to provide the testing laboratory with sufficient sample volume to perform these evaluations. Ten-day static renewal tests using the amphipod, *Hyaella azteca*, and the midge, *Chironomus tentans*, were chosen. The toxicity test utilized four "replicates" per sampling location (or treatment), each replicate containing fifteen organisms. The purpose of these replicates was to determine the

variability within the test organism population within each treatment.

The results reported mean survival for *Hyaella azteca* in the contaminated sediment (8 to 50 percent) to be significantly lower than survival in the uncontaminated reference sediment (85 percent). Similarly, mean survival for *Chironomus tentans* in the contaminated sediment (0 to 63 percent) was significantly lower than survival in the uncontaminated reference sediment (83 percent).

Example No. 2

An inactive manufacturing facility had stored its stock compounds in unprotected piles for a number of years, resulting in DDT contamination of the adjacent watershed. DDT contamination in a stream located adjacent to the site extended from the manufacturing facility to approximately 27 miles downstream.

A field study was designed to quantitatively determine if the levels of DDT in the water and sediment in this stream were resulting in an adverse ecological impact. This was accomplished through the examination of several in situ environmental variables in conjunction with laboratory analyses. Water, sediment, and resident biota were collected and submitted for various physical and chemical determinations. Additional sediments were secured and utilized for toxicity testing with three surrogate species. Finally, the benthic invertebrate community was sampled and the structure and function of this segment of the aquatic ecosystem evaluated.

Benthic invertebrates were collected from three areas at each sampling location (i.e., three "replicates" per location) and evaluated for various quantitative community metrics. The purpose of these replicates were to determine the spatial variability in the stream among the three areas within each sampling location. Community structure, diversity indices, taxonomic evenness, an evaluation of the function feeding groups, and statistical analyses were performed on the data set.

Qualitative and statistical comparison of the results between the contaminated areas and the uncontaminated reference indicated that the benthic invertebrate community was adversely affected downstream of the site compared to the upstream reference. Taxonomic and functional diversity varied inversely with DDT levels in sediment and water. These results were further

substantiated by the toxicity evaluation results.

Example No. 3

Phase I and II Remedial Investigation and Feasibility Studies (RIFS) have indicated that the soils surrounding an industrial and municipal waste disposal site were contaminated with PCBs. A preliminary site survey revealed the presence of small mammal habitat and mammal signs in the natural areas adjacent to the site as well as an area that appeared to be outside of the site's influence (i.e., a potential reference area). A site investigation was subsequently conducted to determine the levels of PCBs accumulating into the resident mammal community from contact with the PCB-contaminated soil.

Three small mammal trapping areas were identified for this site. Two areas were located in PCB-contaminated areas, the third area was a reference. Trapping grids were established in each area consisting of 100 traps of various design. Six soil samples were also collected from each trapping area to characterize the levels of PCBs associated with the anticipated captured mammals.

A total of 32 mammals were collected at this site. Twelve were collected from each on-site area and six were collected from the reference area. All captured mammals were submitted for whole body analysis of PCBs. Mean PCB concentrations in the mammals were as follows: on-site areas (1250 and 1340 $\mu\text{g}/\text{kg}$, wet weight); reference area (490 $\mu\text{g}/\text{kg}$, wet weight). A one-way analysis of variance was conducted on the data set treating each animal in an area as a "replicate" (i.e., 12 replicates from each on-site area and 6 replicates from the reference). The results of the statistical analyses indicated that there was a statistically significant difference between on-site and reference area PCB levels in the mammals ($p < 0.10$). Therefore, in this example, there were no analytical replicates since each individual mammal was analyzed. However, each mammal represented a statistical replicate within each trapping area.

4.4.2 Collocated Samples

A collocated sample is collected from an area adjoining a field sample to determine variability of the matrix and contaminants within a small area of the site. For example, collocated samples for chemistry analysis split

from the sample collected for the toxicity test are collected about one-half to three feet away from the field sample location. Plants collected from within the same sampling plot may be considered collocated. Collocated samples are appropriate for assessing variability only in a small area, and should not be used to assess variability across the entire site or for assessing error.

4.4.3 Reference Samples

Reference biological samples may be taken from a reference area outside the influence of the site. Comparison of results from actual samples and samples from the reference area may indicate uptake, body burden, or accumulation of chemicals on the site. The reference area should be close to the site. It should have habitats, size and terrain similar to the site under investigation. The reference site need not be pristine. Biological reference samples should be of the same species, sex, and developmental stage as the field site sample.

4.4.4 Rinsate Blank Samples

A rinsate blank is used to assess cross-contamination from improper equipment decontamination procedures. Rinsate blanks are samples obtained by running analyte-free water over decontaminated sampling equipment. Any residual contamination should appear in the rinsate data. Analyze the rinsate blank for the same analytical parameters as the field samples collected that day. When dedicated cutting tools or other sampling equipment are not used, collect one rinsate blank per device per day.

4.4.5 Field Blank Samples

Field blanks are samples prepared in the field using certified clean water or sand that are then submitted to the laboratory for analysis. A field blank is used to evaluate contamination or error associated with sampling methodology, preservation, handling/shipping, and laboratory procedures. If appropriate for the test, submit one field blank per day.

4.4.6 Trip Blank Samples

Trip blanks are samples prepared prior to going into the field. They consist of certified clean water or sand, and they are not opened until they reach the laboratory. Use trip blanks when samples are being analyzed for volatile

organics. Handle, transport, and analyze trip blanks in the same manner as the other volatile organic samples collected that day. Trip blanks are used to evaluate error associated with sampling methodology, shipping and handling, and analytical procedures, since any volatile organic contamination of a trip blank would have to be introduced during one of those procedures.

4.4.7 Performance Evaluation /Laboratory Control Samples

A performance evaluation (PE) sample evaluates the overall error from the analytical laboratory and detects any bias in the analytical method being used. PE samples contain known quantities of target analytes manufactured under strict quality control. They are usually prepared by a third party under a U.S. EPA certification program. The samples are usually submitted "blind" to analytical laboratories (the sampling team knows the contents of the samples, but the laboratory does not). Laboratory analytical error (usually bias) may be evaluated by the percent recoveries and correct identification of the components in the PE sample.

4.4.8 Controls

Analytical Laboratory Control Samples

A chemical analytical laboratory control sample (LCS) contains quantities of target analytes known to the laboratory and are used to monitor "controlled" conditions. LCSs are analyzed under the same sample preparation, reagents, and analytical methods as the field samples. LCS results can show bias and/or variability in analytical results.

Toxicity Testing Control Groups

In toxicity tests, a laboratory reference toxicant treatment and a control treatment are both typically utilized in addition to a site reference treatment. This test involves exposing the test organism population to a standardized reference toxicant at a standardized dose, then comparing the response to historical laboratory records for that culture. The mortality results of the newly conducted reference toxicant test should be similar to the historical results. This is conducted to reveal if the generation(s) in the present culture is viable for use in the toxicity test, or if the culture has grown resistant or intolerant to the toxicant over time. Therefore, a laboratory reference

toxicant test should be conducted prior to the testing of the site matrices.

In contrast, a laboratory control test is conducted simultaneously with the testing of the site matrices. This treatment identifies mortality factors that are unrelated to site contaminants. This is accomplished by exposing the test organism population to a clean dilution water and/or a clean laboratory substrate.

4.4.9 Matrix Spike/Matrix Spike Duplicate Samples

Matrix spike and matrix spike duplicate samples (MS/MSDs) are supplemental volumes of field-collected samples that are spiked in the laboratory with a known concentration of a target analyte to determine matrix interference. Matrix interference is determined as a function of the percent analyte recovery in the sample extraction. The percent recovery from MS/MSDs indicates the degree to which matrix interferences will affect the identification and/or quantitation of a substance. MS/MSDs can also be used to monitor laboratory performance. When two or more pairs of MS/MSDs are analyzed, the data obtained may also be used to evaluate error due to laboratory bias and precision. Analyze one MS/MSD pair to assess bias for every 10 samples, and use the average percent recovery for the pair. To assess precision, analyze at least eight matrix spike replicates from the same sample, and determine the standard deviation and the coefficient of variation. See the *U.S. EPA Quality Assurance/Quality Control (QA/QC) Guidance for Removal Activities* (April 1990) for directions on calculating analytical error.

MS/MSDs are a required QA/QC element of the definitive data objectives. MS/MSDs should accompany every 10 samples. Since the MS/MSDs are spiked field samples, sufficient volume for three separate analyses must be provided. Organic analysis of tissue samples is frequently subject to matrix interferences which causes biased analytical results. Matrix spike recoveries are often low or show poor precision in tissue samples. The matrix interferences will be evident in the matrix spike results. Although metals analysis of tissue samples is usually not subject to these interferences, MS/MSD samples should be utilized to monitor method and laboratory performance. Some analytical parameters such as percent lipids, organic carbon, and particle-size distribution are exempt from MS/MSD analyses.

4.4.10 Laboratory Duplicate Samples

A laboratory duplicate is a sample that undergoes preparation and analysis twice. The laboratory takes two aliquots of one sample and treats them as if they were separate samples. Comparison of data from the two analyses provides a measure of analytical reproducibility within a sample set. Discrepancies in duplicate analyses may indicate poor homogenization in the field or other sample preparation error, whether in the field or in the laboratory. However, duplicate analyses are not possible with most tissue samples unless a homogenate of the sample is created.

4.5 Data Evaluation

4.5.1 Evaluation of Analytical Error

Analytical error becomes significant in decision-making as sample results approach the level of environmental impact. The acceptable level of error is determined by the intended use of the data and litigation concerns. To be definitive, analytical data must have quantitative measurement of analytical error with PE samples and replicates. The QA samples identified in this section can indicate a variety of qualitative and quantitative sampling errors. Due to matrix interferences, causes of error may be difficult to determine in organic analysis of tissue samples.

4.5.2 Data Validation

Data from tissue sample analysis may be validated according to the Contract Laboratory Program National Functional Guidelines (U.S. EPA 1994) and according to *U.S. EPA Quality Assurance/Quality Control (QA/QC) Guidance for Removal Activities*, EPA/540/G-90/004, April 1990. Validation of organic data may require an experienced chemist due to complexity of tissue analysis.

5.0 DATA ANALYSIS AND INTERPRETATION

5.1 INTRODUCTION

The main objective of biological surveys conducted at Superfund sites is the assessment of site-related threat or effect. For many types of biological data (e.g., levels of contaminants in organisms collected on site and from a reference location), hypotheses are tested to determine the presence or absence of an effect. For some biological tests (e.g., benthic macroinvertebrate studies, toxicity tests), the data analysis and interpretation process is outlined in existing documents (U.S. EPA November 1990, U.S. EPA May 1996). For many Superfund ecological assessments, a weight-of-evidence approach is used to interpret the results of different studies or tests conducted at a site.

The statistical tests and methods that will be employed should be based on the objective of the data evaluation. These components should be outlined in the Work Plan or Sampling and Analysis Plan. This process will help focus the study to ensure that the appropriate type and number of samples are collected.

5.2 DATA PRESENTATION AND ANALYSIS

5.2.1 Data Presentation Techniques

In many cases, before descriptive statistics are calculated from a data set, it is useful to try various graphical displays of the raw data. The graphical displays help guide the choice of any necessary transformations of the data set and the selection of appropriate statistics to summarize the data. Since most statistical procedures require summary statistics calculated from a data set, it is important that the summary statistics represent the entire data set. For example, the median may be a more appropriate measure of central tendency than the mean for a data set that contains outliers. Graphical display of a data set could indicate the need to log transform data so that symmetry indicates a normal distribution. Four of the most useful graphical techniques are described next.

A histogram is a bar graph that displays the distribution of a data set, and provides information regarding the location of the center of the sample, amount of dispersion,

extent of symmetry, and existence of outliers. Stem and leaf plots are similar to histograms in that they provide information on the distribution of a data set; however they also contain information on the numeric values in the data set. Box and whisker plots can be used to compare two or more samples of the same characteristic (e.g., stream IBI values for two or more years). Scatter plots are a useful method for examining the relationship between two sets of variables. Figure 4 illustrates the four graph techniques described previously.

5.2.2 Descriptive Statistics

Large data sets are often summarized using a few descriptive statistics. Two important features of a set of data are the central tendency and the spread. Statistics used to describe central tendency include the arithmetic mean, median, mode and geometric mean. Spread or dispersion in a data set refers to the variability in the observations about the center of the distribution. Statistics used to describe data dispersion include range and standard deviation. Methods for calculating descriptive statistics can be found in any statistics textbook, and many software programs are available for statistical calculations.

5.2.3 Hypothesis Testing

Biological studies are conducted at Superfund sites to determine adverse effects due to site-related factors. For many types of biological data, hypothesis testing is the statistical procedure used to evaluate data. Hypothesis testing involves statistically evaluating a parameter of concern, such as the mean or median, at a specified probability for incorrectly interpreting the analysis results. In conventional statistical analysis, hypothesis testing for a trend or effect is based on a null hypothesis. Typically, the null hypothesis is presumed when there is no trend or effect present. To test this hypothesis, data are collected to estimate an effect. The data are used to provide a sample estimate of a test statistic, and a table for the test statistic is consulted to determine how unlikely the observed value of the statistic is if the null hypothesis is true. If the observed value of the test statistic is unlikely, the null hypothesis is rejected. In ecological risk assessment, a hypothesis is a question about the relationship among assessment endpoints and their

predicted responses when exposed to contaminants. The most basic hypothesis that is applicable to virtually all Superfund sites is that site-related contaminants are causing adverse effects of the assessment endpoint(s).

assessment, mathematical models, such as the Hazard Quotient method, are used to evaluate the site data against literature toxicity values. Based on the type of model used, the results can be extrapolated to suggest the presence of ecological risk.

5.3 DATA INTERPRETATION

5.3.1 Chemical Residue Studies

Chemical residue data may be evaluated in two ways. First, the contaminant concentrations by themselves provide evidence of bioaccumulation and probable food chain transfer of the contaminants, and an overall picture of the distribution of contaminants in the biological community. Second, the residue data may be evaluated against literature residue values that are known to cause no effect or an adverse effect in the organism.

5.3.2 Population/Community Studies

The interpretation of population/community data is extensive, therefore, the reader is referred to a detailed treatment in U.S. EPA (November 1990), U.S. EPA (1989a), Karr et al. (1986), and other literature.

5.3.3 Toxicity Testing

Measurement endpoints obtained in toxicity tests are generally compared to results from a laboratory control and a reference location sample to determine whether statistically significant differences exist. If significant effects (e.g., mortality, decreased reproduction) are observed, additional statistical analyses can be run to determine whether observed effects correlate with measured contaminant levels. The reader is referred to a detailed treatment in ASTM (1992), U.S. EPA (May 1988), U.S. EPA (March 1989b).

5.3.4 Risk Calculation

Preliminary screening value results are interpreted by comparison of historical and/or new site analytical data against literature toxicity values. This comparison will suggest if the probability of risk exists and whether additional evaluation is desired.

If the evaluation is pursued to an ecological risk

Figure 3 Illustrations of Sample Plots

IBI DATA

12	25	33	56
12	24	34	58
14	26	35	
15	24	36	
16	24	35	
22	27	38	
24	23	41	
23	28	42	

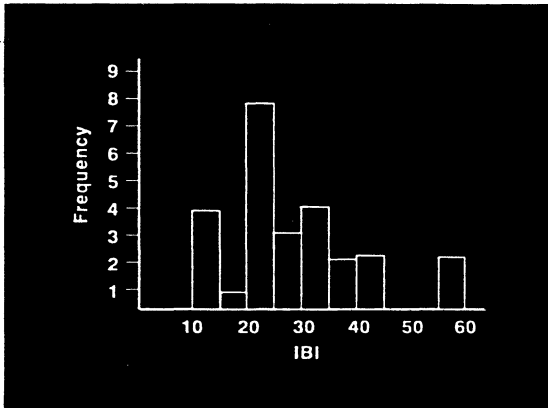

A) Histogram

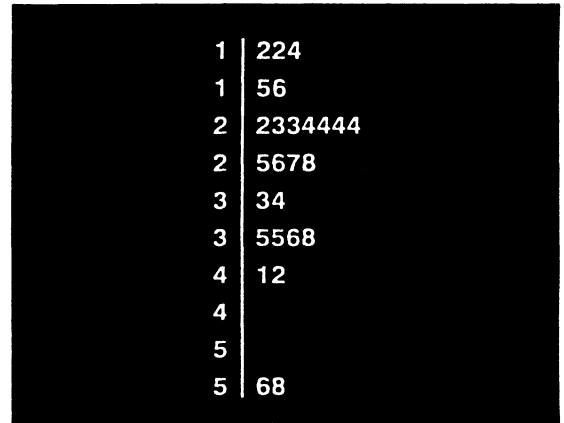

B) Leaf Plot

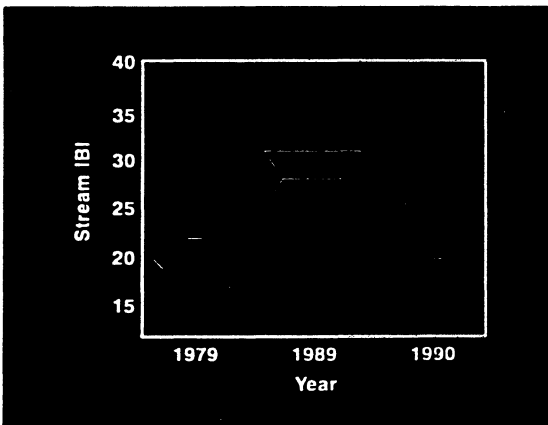

C) Whisker Plot

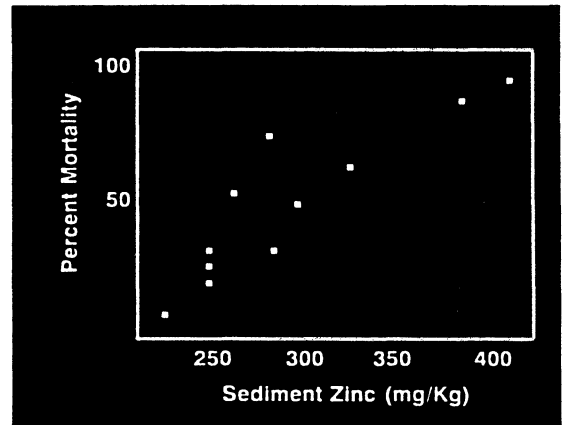

D) Scatter Plot

APPENDIX A - CHECKLIST FOR ECOLOGICAL ASSESSMENT/SAMPLING

Introduction

The checklist that follows provides guidance in making observations for an ecological assessment. It is not intended for limited or emergency response actions (e.g., removal of a few drums) or for purely industrial settings with no discharges. The checklist is a screening tool for preliminary site evaluation and may also be useful in planning more extensive site investigations. It must be completed as thoroughly as time allows. The results of the checklist will serve as a starting point for the collection of appropriate biological data to be used in developing a response action. It is recognized that certain questions in this checklist are not universally applicable and that site-specific conditions will influence interpretation. Therefore, a site synopsis is requested to facilitate final review of the checklist by a trained ecologist.

Checklist

The checklist has been divided into sections that correspond to data collection methods and ecosystem types. These sections are:

- I. Site Description
 - IA. Summary of Observations and Site Setting
- II. Terrestrial Habitat Checklist
 - IIA. Wooded
 - IIB. Shrub/Scrub
 - IIC. Open Field
 - IID. Miscellaneous
- III. Aquatic Habitat Checklist -- Non-Flowing Systems
- IV. Aquatic Habitat Checklist -- Flowing Systems
- V. Wetlands Habitat Checklist

Checklist for Ecological Assessment/Sampling

I. SITE DESCRIPTION

1. Site Name: _____
Location: _____

County: _____ City: _____ State: _____

2. Latitude: _____ Longitude: _____

3. What is the approximate area of the site? _____

4. Is this the first site visit? yes no If no, attach trip report of previous site visit(s), if available.
Date(s) of previous site visit(s): _____

5. Please attach to the checklist USGS topographic map(s) of the site, if available.

6. Are aerial or other site photographs available? yes no If yes, please attach any available photo(s) to the site map at the conclusion of this section.

7. The land use on the site is:

- ____ % Urban
- ____ % Rural
- ____ % Residential
- ____ % Industrial (light heavy)
- ____ % Agricultural

(Crops: _____)

____ % Recreational

(Describe; note if it is a park, etc.)

____ % Undisturbed

____ % Other

The area surrounding the site is:

_____ mile radius

- ____ % Urban
- ____ % Rural
- ____ % Residential
- ____ % Industrial (light heavy)
- ____ % Agricultural

(Crops: _____)

____ % Recreational

(Describe; note if it is a park, etc.)

____ % Undisturbed

____ % Other

8. Has any movement of soil taken place at the site? yes no. If yes, please identify the most likely cause of this disturbance:

____ Agricultural Use

____ Heavy Equipment

____ Mining

____ Natural Events

____ Erosion

____ Other

Please describe:

9. Do any potentially sensitive environmental areas exist adjacent to or in proximity to the site, e.g., Federal and State parks, National and State monuments, wetlands, prairie potholes? *Remember, flood plains and wetlands are not always obvious; do not answer "no" without confirming information.*

Please provide the source(s) of information used to identify these sensitive areas, and indicate their general location on the site map.

10. What type of facility is located at the site?

Chemical Manufacturing Mixing Waste disposal

Other (specify) _____

11. What are the suspected contaminants of concern at the site? If known, what are the maximum concentration levels?

12. Check any potential routes of off-site migration of contaminants observed at the site:

Swales Depressions Drainage ditches

Runoff Windblown particulates Vehicular traffic

Other (specify) _____

13. If known, what is the approximate depth to the water table? _____

14. Is the direction of surface runoff apparent from site observations? yes no If yes, to which of the following does the surface runoff discharge? Indicate all that apply.

Surface water Groundwater Sewer Collection impoundment

15. Is there a navigable waterbody or tributary to a navigable waterbody? yes no

16. Is there a waterbody anywhere on or in the vicinity of the site? If yes, also complete Section III: Aquatic Habitat Checklist -- Non-Flowing Systems and/or Section IV: Aquatic Habitat Checklist -- Flowing Systems.

yes (approx. distance _____) no

17. Is there evidence of flooding? yes no *Wetlands and flood plains are not always obvious; do not answer "no" without confirming information.* If yes, complete Section V: Wetland Habitat Checklist.

18. If a field guide was used to aid any of the identifications, please provide a reference. Also, estimate the time spent identifying fauna. [Use a blank sheet if additional space is needed for text.]

19. Are any threatened and/or endangered species (plant or animal) known to inhabit the area of the site? yes no
If yes, you are required to verify this information with the U.S. Fish and Wildlife Service. If species' identities are known, please list them next.

20. Record weather conditions at the time this checklist was prepared:

DATE: _____

_____ Temperature (°C/°F)

_____ Normal daily high temperature

_____ Wind (direction/speed)

_____ Precipitation (rain, snow)

_____ Cloud cover

IA. SUMMARY OF OBSERVATIONS AND SITE SETTING

Completed by _____ Affiliation _____

Additional Preparers _____

Site Manager _____

Date _____

II. TERRESTRIAL HABITAT CHECKLIST

IIA. WOODED

1. Are there any wooded areas at the site? yes no If no, go to Section IIB: Shrub/Scrub.
2. What percentage or area of the site is wooded? (_____% _____ acres). Indicate the wooded area on the site map which is attached to a copy of this checklist. Please identify what information was used to determine the wooded area of the site.
3. What is the dominant type of vegetation in the wooded area? (Circle one: Evergreen/Deciduous/ Mixed) Provide a photograph, if available.

Dominant plant, if known: _____

4. What is the predominant size of the trees at the site? Use diameter at breast height.
 0-6 in. 6-12 in. > 12 in.
5. Specify type of understory present, if known. Provide a photograph, if available.

IIB. SHRUB/SCRUB

1. Is shrub/scrub vegetation present at the site? yes no If no, go to Section IIC: Open Field.
2. What percentage of the site is covered by scrub/shrub vegetation? (_____% _____ acres). Indicate the areas of shrub/scrub on the site map. Please identify what information was used to determine this area.
3. What is the dominant type of scrub/shrub vegetation, if known? Provide a photograph, if available.
4. What is the approximate average height of the scrub/shrub vegetation?
 0-2 ft. 2-5 ft. > 5 ft.

5. Based on site observations, how dense is the scrub/shrub vegetation?

- Dense Patchy Sparse

II.C. OPEN FIELD

1. Are there open (bare, barren) field areas present at the site? yes no If yes, please indicate the type below:

- Prairie/plains Savannah Old field Other (specify) _____

2. What percentage of the site is open field? (_____% _____ acres). Indicate the open fields on the site map.

3. What is/are the dominant plant(s)? Provide a photograph, if available.

4. What is the approximate average height of the dominant plant? _____

5. Describe the vegetation cover: Dense Sparse Patchy

II.D. MISCELLANEOUS

1. Are other types of terrestrial habitats present at the site, other than woods, scrub/shrub, and open field? yes no
If yes, identify and describe them below.

2. Describe the terrestrial miscellaneous habitat(s) and identify these area(s) on the site map.

III. AQUATIC HABITAT CHECKLIST -- NON-FLOWING SYSTEMS

Note: Aquatic systems are often associated with wetland habitats. Please refer to Section V, Wetland Habitat Checklist.

1. What type of open-water, non-flowing system is present at the site?

- Natural (pond, lake)
- Artificially created (lagoon, reservoir, canal, impoundment)

2. If known, what is the name(s) of the waterbody(ies) on or adjacent to the site?

3. If a waterbody is present, what are its known uses (e.g.: recreation, navigation, etc.)?

4. What is the approximate size of the waterbody(ies)? _____ acre(s).

5. Is any aquatic vegetation present? yes no If yes, please identify the type of vegetation present if known.

- Emergent
- Submergent
- Floating

6. If known, what is the depth of the water? _____

7. What is the general composition of the substrate? Check all that apply.

- Bedrock
- Sand (coarse)
- Muck (fine/black)
- Boulder (>10 in.)
- Silt (fine)
- Debris
- Cobble (2.5-10 in.)
- Marl (shells)
- Detritus
- Gravel (0.1-2.5 in.)
- Clay (slick)
- Concrete
- Other (specify) _____

8. What is the source of water in the waterbody?

- River/Stream/Creek
- Groundwater
- Other (specify) _____
- Industrial discharge
- Surface runoff

9. Is there a discharge from the site to the waterbody? yes no If yes, please describe this discharge and its path.

10. Is there a discharge from the waterbody? yes no If yes, and the information is available, identify from the list below the environment into which the waterbody discharges.

- | | | | |
|---|---------------------------------|----------------------------------|---------------|
| <input type="checkbox"/> River/Stream/Creek | <input type="checkbox"/> onsite | <input type="checkbox"/> offsite | Distance_____ |
| <input type="checkbox"/> Groundwater | <input type="checkbox"/> onsite | <input type="checkbox"/> offsite | |
| <input type="checkbox"/> Wetland | <input type="checkbox"/> onsite | <input type="checkbox"/> offsite | Distance_____ |
| <input type="checkbox"/> Impoundment | <input type="checkbox"/> onsite | <input type="checkbox"/> offsite | |

11. Identify any field measurements and observations of water quality that were made. For those parameters for which data were collected provide the measurement and the units of measure below:

- _____ Area
- _____ Depth (average)
- _____ Temperature (depth of the water at which the reading was taken) _____
- _____ pH
- _____ Dissolved oxygen
- _____ Salinity
- _____ Turbidity (clear, slightly turbid, turbid, opaque) (Secchi disk depth _____)
- _____ Other (specify)

12. Describe observed color and area of coloration.

13. Mark the open-water, non-flowing system on the site map attached to this checklist.

14. What observations, if any, were made at the waterbody regarding the presence and/or absence of benthic macroinvertebrates, fish, birds, mammals, etc.?

IV. AQUATIC HABITAT CHECKLIST -- FLOWING SYSTEMS

Note: Aquatic systems are often associated with wetland habitats. Please refer to Section V, Wetland Habitat Checklist.

1. What type(s) of flowing water system(s) is (are) present at the site?

- | | | |
|---|---|-------------------------------------|
| <input type="checkbox"/> River | <input type="checkbox"/> Stream | <input type="checkbox"/> Creek |
| <input type="checkbox"/> Dry wash | <input type="checkbox"/> Arroyo | <input type="checkbox"/> Brook |
| <input type="checkbox"/> Artificially
created
(ditch, etc.) | <input type="checkbox"/> Intermittent Stream | <input type="checkbox"/> Channeling |
| | <input type="checkbox"/> Other (specify)_____ | |

2. If known, what is the name of the waterbody?_____

3. For natural systems, are there any indicators of physical alteration (e.g., channeling, debris, etc.)?

- yes no If yes, please describe indicators that were observed.

4. What is the general composition of the substrate? Check all that apply.

- | | | |
|---|--|---|
| <input type="checkbox"/> Bedrock | <input type="checkbox"/> Sand (coarse) | <input type="checkbox"/> Muck (fine/black) |
| <input type="checkbox"/> Boulder (>10 in.) | <input type="checkbox"/> Silt (fine) | <input type="checkbox"/> Debris |
| <input type="checkbox"/> Cobble (2.5-10 in.) | <input type="checkbox"/> Marl (shells) | <input type="checkbox"/> Detritus |
| <input type="checkbox"/> Gravel (0.1-2.5 in.) | <input type="checkbox"/> Clay (slick) | <input type="checkbox"/> Concrete |
| <input type="checkbox"/> Other (specify)_____ | | |

5. What is the condition of the bank (e.g., height, slope, extent of vegetative cover)?

6. Is the system influenced by tides? yes no What information was used to make this determination?

7. Is the flow intermittent? yes no If yes, please note the information that was used in making this determination.

8. Is there a discharge from the site to the waterbody? yes no If yes, please describe the discharge and its path.

9. Is there a discharge from the waterbody? yes no If yes, and the information is available, please identify what the waterbody discharges to and whether the discharge is on site or off site.

10. Identify any field measurements and observations of water quality that were made. For those parameters for which data were collected, provide the measurement and the units of measure in the appropriate space below:

- _____ Width (ft.)
- _____ Depth (ft.)
- _____ Velocity (specify units): _____
- _____ Temperature (depth of the water at which the reading was taken _____)
- _____ pH
- _____ Dissolved oxygen
- _____ Salinity
- _____ Turbidity (clear, slightly turbid, turbid, opaque)
(Secchi disk depth _____)
- _____ Other (specify) _____

11. Describe observed color and area of coloration.

12. Is any aquatic vegetation present? yes no If yes, please identify the type of vegetation present, if known.

Emergent

Submergent

Floating

13. Mark the flowing water system on the attached site map.

14. What observations were made at the waterbody regarding the presence and/or absence of benthic macroinvertebrates, fish, birds, mammals, etc.?

V. WETLAND HABITAT CHECKLIST

1. Based on observations and/or available information, are designated or known wetlands definitely present at the site?
 yes no

Please note the sources of observations and information used (e.g., USGS Topographic Maps, National Wetland Inventory, Federal or State Agency, etc.) to make this determination.

2. Based on the location of the site (e.g., along a waterbody, in a floodplain) and site conditions (e.g., standing water; dark, wet soils; mud cracks; debris line; water marks), are wetland habitats suspected?
 yes no If yes, proceed with the remainder of the wetland habitat identification checklist.

3. What type(s) of vegetation are present in the wetland?

- Submergent Emergent
 Scrub/Shrub Wooded
 Other (specify) _____

4. Provide a general description of the vegetation present in and around the wetland (height, color, etc.). Provide a photograph of the known or suspected wetlands, if available.

5. Is standing water present? yes no If yes, is this water: Fresh Brackish
What is the approximate area of the water (sq. ft.)? _____

Please complete questions 4, 11, 12 in Checklist III - Aquatic Habitat -- Non-Flowing Systems.

6. Is there evidence of flooding at the site? What observations were noted?

- Buttressing Water marks Mud cracks
 Debris line Other (describe below)

7. If known, what is the source of the water in the wetland?

- Stream/River/Creek/Lake/Pond
- Groundwater
- Flooding
- Surface Runoff

8. Is there a discharge from the site to a known or suspected wetland? yes no If yes, please describe.

9. Is there a discharge from the wetland? yes no. If yes, to what waterbody is discharge released?

- Surface Stream/River
- Groundwater
- Lake/Pond
- Marine

10. If a soil sample was collected, describe the appearance of the soil in the wetland area. Circle or write in the best response.

Color (blue/gray, brown, black, mottled) _____

Water content (dry, wet, saturated/unsaturated) _____

11. Mark the observed wetland area(s) on the attached site map.

APPENDIX B -- Example of Flow Diagram For Conceptual Site Model

Figure B-1

Migration Routes of a Gas Contaminant from Origin to Receptor

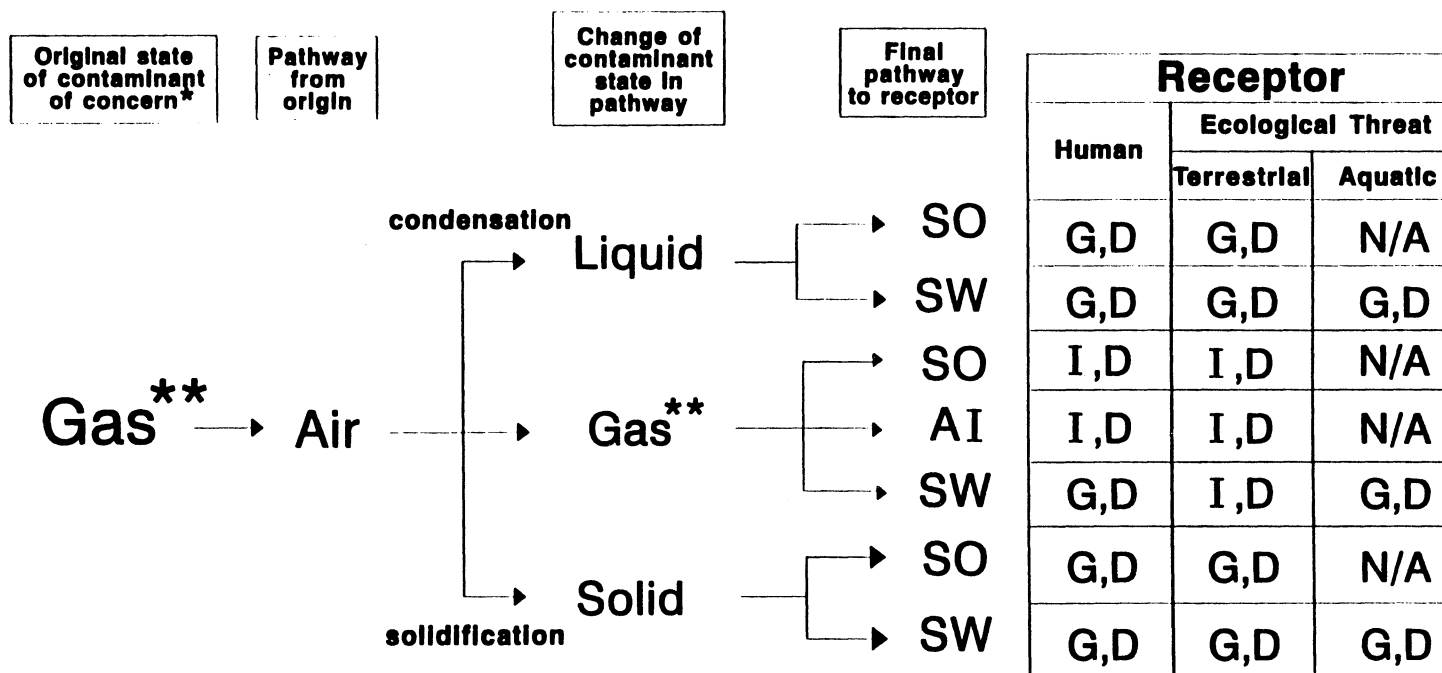

* May be a transformation product
 ** Includes vapors

Receptor Key	
D	= Dermal Contact
I	= Inhalation
G	= Ingestion
N/A	= Not Applicable

Pathway Key	
AI	= Air
SO	= Soil
SW	= Surface Water (including sediments)
GW	= Ground Water

Figure B-2

Migration Routes of a Liquid Contaminant from Origin to Receptor

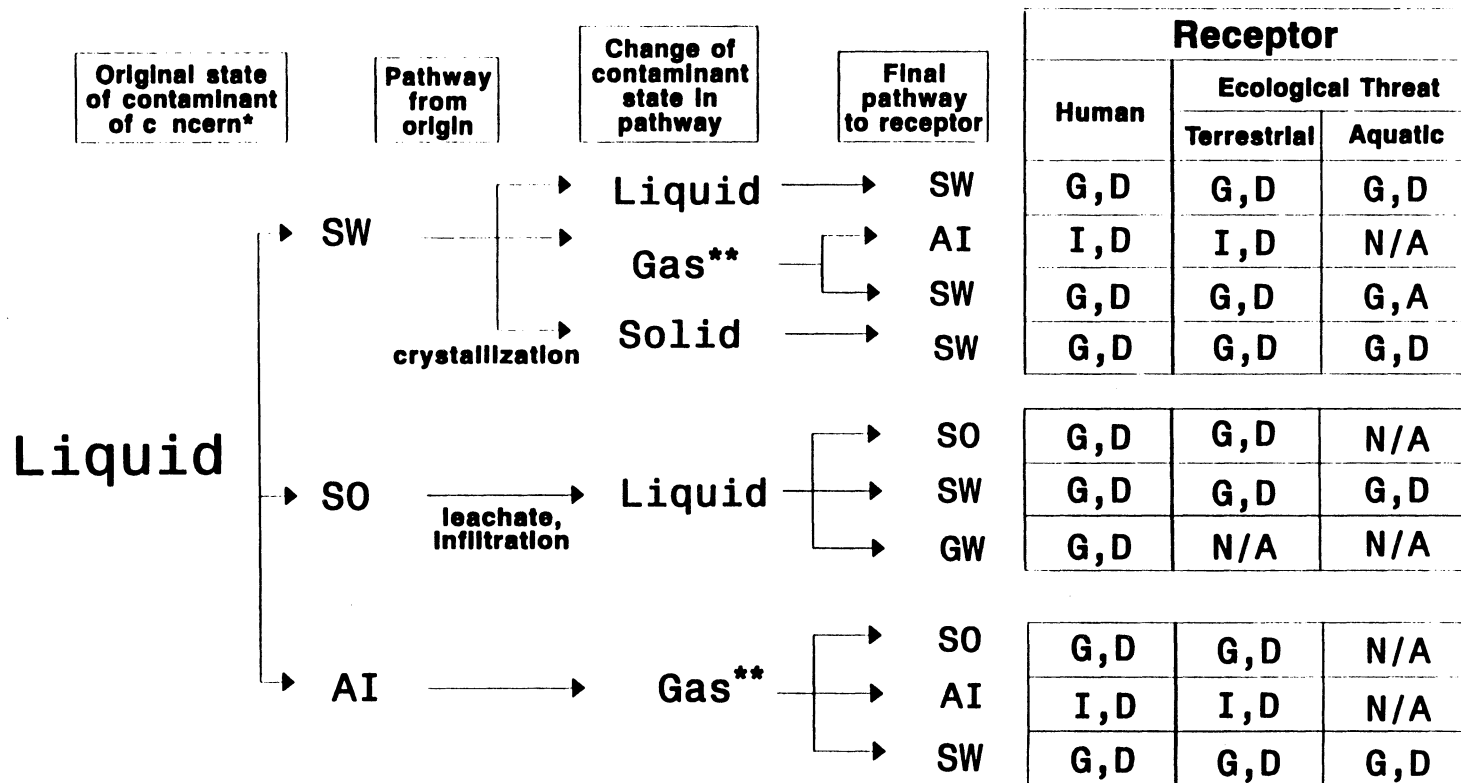

* May be a transformation product
 ** Includes vapors

Pathway Key

AI = Air
 SO = Soil
 SW = Surface Water
 (including sediments)
 GW = Ground Water

Receptor Key

D = Dermal Contact
 I = Inhalation
 G = Ingestion
 N/A = Not Applicable

Figure B-3

Migration Routes of a Solid Contaminant from Origin to Receptor

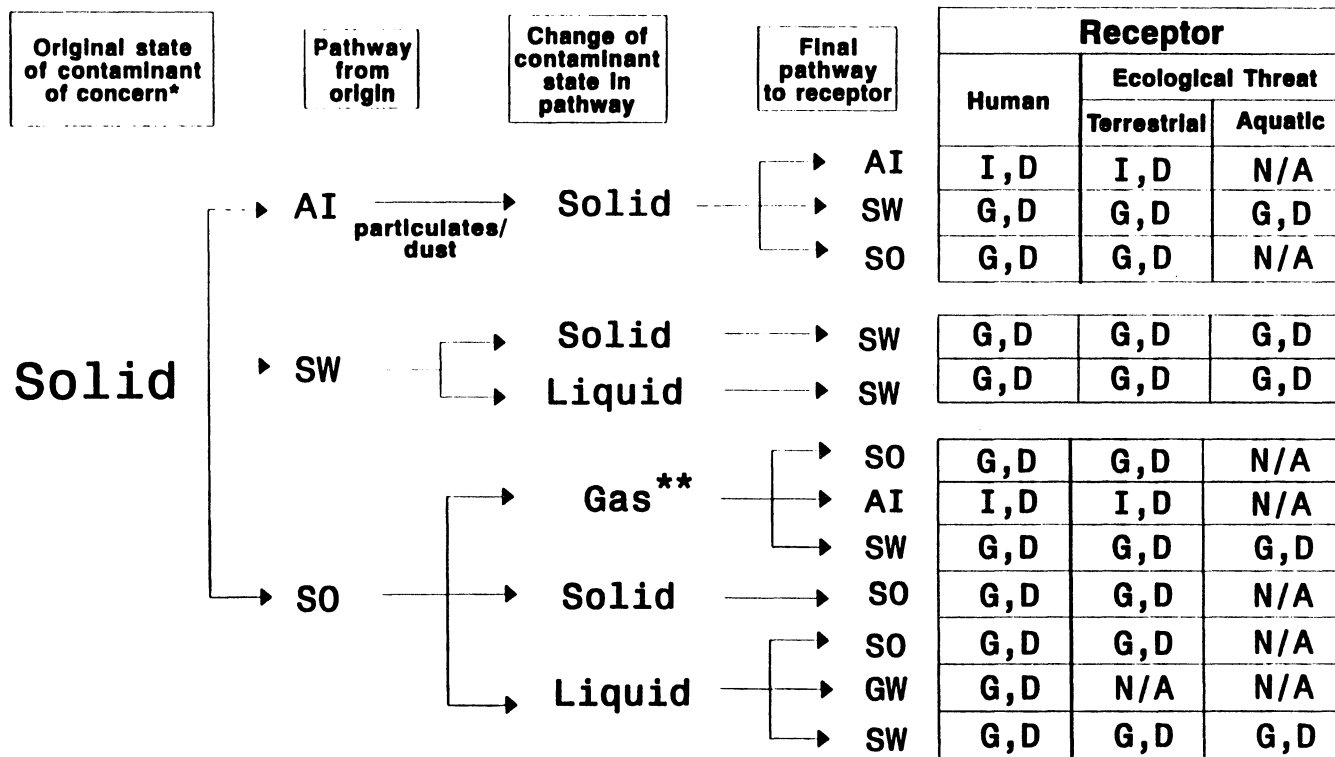

* May be a transformation product
 ** Includes vapors

Receptor Key
D = Dermal Contact
I = Inhalation
G = Ingestion
N/A = Not Applicable

Pathway Key
AI = Air
SO = Soil
SW = Surface Water (including sediments)
GW = Ground Water

APPENDIX C - EXAMPLE SITES

Example sites are presented in this document to demonstrate how information from the checklist for ecological assessment/sampling is used in conjunction with representative biological sampling to meet the study objectives. A general history for each site is presented first, then additional preliminary information

I. SITE HISTORIES

Site A -- Copper Site

This is a former municipal landfill located in an upland area of the mid-Atlantic plain. Residential, commercial, and industrial refuse were disposed at the site from 1961 to 1980. Large amounts of copper wire were also disposed at this site. Minimal grass cover has been placed over the fill. Terrestrial ecosystems in the vicinity of the landfill include upland forest, successional fields, agricultural land, and residential and commercial areas. The surface of the landfill has deteriorated in several locations. Leachate seeps have been noted on the slope of the landfill, several of which discharge to a 5-acre pond down-gradient of the site.

Site B -- Stream DDT Site

This is a former chemical production facility located adjacent to a stream. The facility manufactured and packaged dichlorodiphenyltrichloroethane (DDT). Due to poor storage practices, several DDT spills have occurred.

Site C -- Terrestrial PCB Site

This site is a former waste oil recycling facility located in a remote area. Oils contaminated with polychlorinated biphenyl compounds (PCBs) were disposed in a lagoon. The lagoon is not lined and the substrate is composed mostly of sand. Oils contaminated with PCBs have migrated through the soil and contaminated a wide area adjacent to the site.

II. USE OF THE CHECKLIST FOR ECOLOGICAL ASSESSMENT/SAMPLING

Site A -- Copper Site

A preliminary site visit was conducted, and the checklist indicated the following: 1) the pond has an organic substrate, 2) emergent vegetation including cattail and *Phragmites* occurs along the shore near the leachate seeps, and 3) the pond reaches a depth of five feet toward the middle. Several species of sunfish, minnows, and carp were observed. A diverse benthic macroinvertebrate community also has been noted in the pond. The pond appears to function as a valuable habitat for fish and other wildlife.

Preliminary sampling indicated elevated copper levels in the seep as well as elevated base cations, total organic carbon (TOC), and depressed pH levels (pH 5.7).

Copper can cause toxic effects in both aquatic plants and invertebrates at relatively low water concentrations, thereby affecting the pond's ability to support macroinvertebrate and fish communities, as well as the wildlife that feed at the pond. Terrestrial ecosystems do not need to be evaluated because the overland flow of the seeps is limited to short gullies. Thus, the area of concern has been identified as the 5-acre pond and the associated leachate seeps.

A review of the literature on the ecotoxicity of copper to aquatic biota and plants, both algae and vascular, was conducted. In general it was found that young organisms are more sensitive to copper with decreasing sensitivity as body weight increases. The toxicity of copper in water is influenced by water hardness, alkalinity, and pH.

Site B -- Stream DDT Site

The ecological checklist was completed as part of the preliminary site visit. The information gathered indicates that surface water drainage from the site flows through several drainage swales toward a small unnamed creek. This creek is a second order stream containing riffle-run areas and small pools. The stream substrate is composed of sand and gravel in the pools with some small depositional areas in the backwater areas, and primarily cobble in the riffles. Previous sampling efforts have indicated the presence of DDT and its metabolites in the stream sediments at a concentration of 230 milligrams per kilogram (mg/kg). A variety of wildlife, especially piscivorous birds, utilize this area for feeding. Many species of minnow have been noted in this stream. DDT is well known for its tendency to bioaccumulate and biomagnify in food chains, and available evidence indicates that it can cause reproductive failure in birds due to eggshell thinning.

In freshwater systems, DDT can have direct effects on animals, particularly insects. A literature review of the aquatic toxicity of DDT was conducted, and a no observed adverse effects level (NOAEL) was identified for aquatic insects. Aquatic plants are not affected by DDT. Additional information on the effects of DDT on birds identified decreased reproductive success due to eggshell thinning.

Site C -- Terrestrial PCB Site

During a preliminary site visit, the ecological checklist was completed. Most of the habitat is upland forest, old field, and successional terrestrial areas. Biological surveys at this site have noted a variety of small mammals, and red-tailed hawks were also observed. The area of concern has been identified as the 10-acre area surrounding the site. PCBs have been shown to reduce reproductive success in mammals or target liver functions. PCBs are not highly volatile, so inhalation of PCBs would not be an important exposure pathway. However, PCBs have been shown to biomagnify indicating that the ingestion exposure route needs evaluation. Shrews and/or voles would be appropriate mammalian receptors to evaluate for this exposure route. Potential reproductive effects on predators that feed on small mammals would also be important to evaluate. The literature has indicated that exposure to PCBs through the food chain can cause chronic toxicity to predatory birds.

Limited information was available on the effects of PCBs to red-tailed hawks. Studies on comparable species have indicated decreased sperm concentration that may affect reproductive success.

III. CONCEPTUAL SITE MODEL FORMULATION

Site A -- Copper Site

The assessment endpoint for this site was identified as the maintenance of pond fish and invertebrate community composition similar to that of other ponds in the area of similar size and characteristics. Benthic macroinvertebrate community studies may be relatively labor-intensive and potentially an insensitive measure in this type of system. Measuring the fish community would also be unsuitable due to the limited size of the pond and the expected low diversity of fish species. In addition, copper is not strongly food-chain transferrable. Therefore, direct toxicity testing was selected as an appropriate measurement endpoint. Toxicity was defined as a statistically significant decrease in survival or juvenile growth rates in a population exposed to water or sediments, as compared to a population from the reference sites.

One toxicity test selected was a 10-day solid-phase sediment toxicity test using early life-stage *Hyalella azteca*. The measurement endpoints for the test are mortality and growth rates (measured as length and weight changes). Two water-column toxicity tests were selected: a 7-day test using the alga *Selenastrum capricornutum* (growth test) and a 7-day larval fish test using *Pimephales promelas* (mortality and growth endpoints).

Five sediment samples were collected from the pond bottom at intervals along an identified concentration gradient. Reference sediment was also collected. A laboratory control was utilized in addition to the reference sediment in this toxicity test. The study design specified that sediment for the toxicity tests was collected from the leachate seeps known to be at the pond edge, and from four additional locations transecting the pond at equidistance locations. A pre-sampling visit was required to confirm that the seep was flowing due to the intermittent nature of leachate seeps.

Site B -- Stream DDT Site

A conceptual model was developed to evaluate the environmental pathways for DDT that could result in ecological impacts. DDT in the sediments can be released to the water column during natural resuspension and redistribution of the sediments. Some diffusion of DDT to the water column from the sediment surface may also occur. The benthic macroinvertebrate community would be an initial receptor for the DDT in sediments. Fish that feed on the benthic macroinvertebrates could be exposed to the DDT both in the water column and in their food. Piscivorous birds would be exposed to the DDT that has accumulated in the fish. For example, belted kingfishers are known to feed in the stream. Given the natural history of this species, it is possible that they forage entirely in the contaminated area. From this information, the assessment endpoint was identified to be the protection of piscivorous birds from eggshell thinning due to DDT exposure. From this assessment endpoint, eggshell thinning in the belted kingfisher was selected as the measurement endpoint.

Existing information identified a DDT gradient in the stream sediments. Forage fish (e.g., creek chub) were selected to measure exposure levels for kingfishers. The study design for measuring DDT residue levels specified that 10 creek chub of the same size and sex will be collected at each location for chemical residue analysis. Although analytical data for the stream sediment exists, new co-located sediment samples were specified to be collected to provide a stronger link between the present state of contamination in the sediment and in the fish.

Site C -- Terrestrial PCB Site

A conceptual model was prepared to determine the exposure pathways by which predatory birds could be exposed to PCBs originating in the soil at the site. The prey of red-tailed hawks includes voles, deer mice, and various insects. Voles are herbivorous and prevalent at the site. However, PCBs do not strongly accumulate in plants, thus voles may not represent a strong exposure pathway to hawks. Deer mice are omnivorous and may be more likely than voles to be exposed to PCBs. The assessment endpoint for this site was identified to be the protection of reproductive success in high trophic level species exposed to PCBs via diet.

Initially, a sampling feasibility study was conducted to confirm sufficient numbers of the deer mice. Two survey lines of 10 live traps were set for deer mice in the area believed to contain the desired concentration gradient for the study design. Previous information indicated a gradient of decreasing PCB concentration with increasing distance from the unlined lagoon. Three locations were selected along this gradient to measure PCB concentrations in prey. Co-located soil and water samples were also collected. The analytical results of these matrices were utilized as variables in a food chain accumulation model which predicted the amount of contaminant in the environment that may travel through the food chain, ultimately to the red-tailed hawk.

REFERENCES

- ASTM. 1992. *Standard Guide for Conducting Early Life-Stage Toxicity Tests with Fishes*. American Society for Testing and Materials. E1241-92.
- Bligh, E.G., W.J. Dyer. 1959. *Lipid Extraction and Purification*. Canadian Journal of Biochemistry and Physiology. Vol 37. pp. 912-917
- Brungs, W.A. and D.I. Mount. 1978. *Introduction to a Discussion of the Use of Aquatic Toxicity Tests for Evaluation of the Effects of Toxic Substances*. Cairns, J. Jr., K.L. Dickson and A.W. Makei (eds.) Estimating the Hazard of Chemical Substances to Aquatic Life. ASTM 657. Amer. Soc. Test. Materials, Philadelphia, PA. p. 1526.
- Green, J.C., C.L. Bartels, W.J. Warren-Hicks, B.R. Parkhurst, G.L. Linder, S.A. Peterson, and W.E. Meiller. 1989. *Protocol for Short Term Toxicity Screening of Hazardous Waste*. U.S. Environmental Protection Agency, Environmental Research Laboratory, Corvallis, OR. EPA 600/3-88/029.
- Hair, J.D. 1980. Measurement of ecological diversity. in S.D. Schemnitz, ed. *Wildlife Management Techniques Manual*. Fourth Edition. The Wildlife Society, Washington, D.C. pp269-275.
- Hayes, M.L. 1983. Active Fish Capture Methods, Chapter 7 in *Fisheries Techniques*. American Fisheries Society. pp. 123-145.
- Herbes, S.E. and C.P. Allen. 1983. *Lipid Quantification of Freshwater Invertebrates: Method Modification for Microquantitation*. Canadian Journal of Fisheries and Aquatic Sciences. 40(8). pp. 1315-1317.
- Hurbert, W.A. 1983. Passive Capture Methods, Chapter 6 in *Fisheries Techniques*. American Fisheries Society. pp. 95-122.05
- Karr, J.R., K.D. Fausch, P.L. Angermeier, P.R. Yant, and I.J. Schlosser. 1986. *Assessing Biological Integrity in Running Waters: A Method and Its Rationale*. Special Publication 5. Illinois Natural History Survey.
- Philips, D.J.H. 1977. The Use of Biological Indicator Organisms to Monitor Trace Metal Pollution In Marine and Estuarine Environments-A Review. *Environmental Poll.* 13, pp. 281-317.
- Philips, D.J.H. 1978. Use of Biological Indicator Organisms to Quantitate Organochlorine Pollutants in Aquatic Environments-A Review. *Environmental Poll.* 16, pp. 167-229.
- Timbrell, J.A. 1989. *Introduction to Toxicology*. Taylor and Francis, London. 155p.
- U.S. EPA (Environmental Protection Agency). 1997. *Ecological Risk Assessment Guidance for Superfund: Process for Designing and Conducting Ecological Risk Assessments*. Office of Solid Waste and Emergency Response. EPA 540-R-97/006.
- U.S. EPA (Environmental Protection Agency). 1994. *CLP National Functional Guidelines for Inorganic Data Review*. Office of Solid Waste and Emergency Response. Publication 9240.1-05
- U.S. EPA (Environmental Protection Agency). January 1991. *Compendium of ERT Toxicity Testing Procedures*. OSWER Directive 9360.4-08.

U.S. EPA (Environmental Protection Agency). 1992. *Framework for Ecological Risk Assessment*. EPA/630/R-92/001.

U.S. EPA (Environmental Protection Agency). December 1991b. ECO Update. Volume 1, Number 2, Publication 9345.0-05I. Office of Emergency and Remedial Response, Hazardous Site Evaluation Division (OS-230).

U.S. EPA (Environmental Protection Agency). April 1990. *Quality Assurance/Quality Control (QA/QC) Guidance for Removal Activities, Sampling QA/QC Plan and Data Validation Procedures*. EPA/540/G-90/004.

U.S. EPA (Environmental Protection Agency). November 1990. *Macroinvertebrate Field and Laboratory Methods for Evaluating the Biological Integrity of Surface Waters*. Aquatic Biology Branch and Development and Evaluation Branch, Quality Assurance Research Division, Environmental Monitoring Systems Laboratory, Cincinnati, Ohio, EPA/600/4-90/030.

U.S. EPA (Environmental Protection Agency). March 1989b. *Short-Term Methods for Estimating the Chronic Toxicity of Effluents and Receiving Waters to Freshwater Organisms*. EPA/600/4-89/001.

U.S. Environmental Protection Agency. May 1989a. *Rapid Bioassessment Protocols For Use In Streams And Rivers: Benthic Macroinvertebrates and Fish*. EPA/444/4-89-001.

U.S. Environmental Protection Agency. May 1988. *Short-Term Methods for Estimating the Chronic Toxicity of Effluents and Receiving Waters to Marine and Estuarine Organisms*. EPA/600/4-87/028.

APPENDIX C

SUPPLEMENTAL GUIDANCE ON LITERATURE SEARCH

APPENDIX C

SUPPLEMENTAL GUIDANCE ON LITERATURE SEARCH

A literature search is conducted to obtain information on contaminants of concern, their potential ecological effects, and species of concern. This appendix is separated into two sections; Section C-1 describes the information necessary for the literature review portion of an ecological risk assessment. Topics include information for exposure profiles, bioavailability or bioconcentration factors for various compounds, life-history information for the species of concern or the surrogate species, and an ecological effects profile. Section C-2 lists information sources and techniques for a literature search and review. Topics include a discussion of how to select key words on which to base a search and various sources of information (i.e., databases, scientific abstracts, literature reviews, journal articles, and government documents). Threatened and endangered species are discussed separately due to the unique databases and information sources available for these species.

Prior to conducting a literature search, it is important to determine what information is needed for the ecological risk assessment. The questions raised in Section D-1 must be thoroughly reviewed, the information necessary to complete the assessment must be determined, and the purpose of the assessment must be clearly defined. Once these activities are completed, the actual literature search can begin. These activities will assist in focusing and streamlining the search.

C-1 LITERATURE REVIEW FOR AN ECOLOGICAL RISK ASSESSMENT

Specific information. During problem formulation, the risk assessor must determine what information is needed for the risk assessment. For example, if the risk assessment will estimate the effects of lead contamination of soils on terrestrial vertebrates, then literature information on the effects of dissolved lead to fish would not be relevant. The type and form of the contaminant and the biological species of concern often can focus the literature search. For example, the toxicity of organometallic compounds is quite different from the comparable inorganic forms. Different isomers of organic compounds also can have different toxic effects.

Reports of toxicity tests should be reviewed critically to ensure that the study was scientifically sound. For example, a report should specify the exposure routes, measures of effect and exposure, and the full study design. Moreover, whether the investigator used accepted scientific techniques should be determined.

The exposure route used in the study should also be comparable to the exposure route in the risk assessment. Data reported for studies where exposure is by injection or gavage are not directly comparable to dietary exposure studies. Therefore, an uncertainty factor might

need to be included in the risk assessment study design, or the toxicity report should not be used in the risk assessment.

To use some data reported in the literature, dose conversions are necessary to estimate toxicity levels for species other than those tested. Doses for many laboratory studies are reported in terms of mg contaminant/kg diet, sometimes on a wet-weight basis and sometimes on a dry-weight basis. That expression should be converted to mg contaminant/kg wet bodyweight/day, so that estimates of an equivalent dose in another species can be scaled appropriately. Average ingestion rate and wet body weight for a species often are reported in the original toxicity study. If not, estimates of those data can be obtained from other literature sources to make the dose conversion:

$$\text{Dose} = (\text{mg contaminant/kg diet}) \times \text{ingestion rate (kg/day)} \times (1/\text{wet body weight (kg)}).$$

If the contaminant concentration is expressed as mg contaminant/kg dry diet, the ingestion rate should also be in terms of kg of dry diet ingested per day.

Exposure profile. Once contaminants of concern are selected for the ecological risk assessment, a general overview of the contaminants' physical and chemical properties is needed. The fate and transport of contaminants in the environment determines how biota are likely to be exposed. Many contaminants undergo degradation (e.g., hydrolysis, photolysis, microbial) after release into the environment. Degradation can affect toxicity, persistence, and fate and transport of compounds. Developing an exposure profile for a contaminant requires information regarding inherent properties of the contaminant that can affect fate and transport or bioavailability.

Bioavailability. Of particular importance in an ecological risk assessment is the bioavailability of site contaminants in the environment. Bioavailability influences exposure levels for the biota. Some factors that affect bioavailability of contaminants in soil and sediment include the proportion of the medium composed of organic matter, grain size of the medium, and its pH. The aerobic state of sediments is important because it often affects the chemical form of contaminants. Those physical properties of the media can change the chemical form of a contaminant to a form that is more or less toxic than the original contaminant. Many contaminants adsorb to organic matter, which can make them less bioavailable.

Environmental factors that influence the bioavailability of a contaminant in water are important to aquatic risk assessments. Factors including pH, hardness, or aerobic status can determine both the chemical form and uptake of contaminants by biota. Other environmental factors can influence how organisms process contaminants. For example, as water temperatures rise, metabolism of fish and aquatic invertebrates increases, and the rate of uptake of a contaminant from water can increase.

If the literature search on the contaminants of concern reveals information on the bioavailability of a contaminant, then appropriate bioaccumulation or bioconcentration factors (BAFs or BCFs) for the contaminants should be determined. If not readily available in the literature, BAF or BCF values can be estimated from studies that report contaminant concentrations in both the environmental exposure medium (e.g., sediments) and in the exposed biota (e.g., benthic macroinvertebrates). Caution is necessary, however, when extrapolating BAF or BCF values estimated for one ecosystem to another ecosystem.

Life history. Because it is impossible and unnecessary to model an entire ecosystem, the selection of assessment endpoints and associated species of concern, and measurement endpoints (including those for a surrogate species if necessary) are fundamental to a successful risk assessment. This process is described in Steps 3 and 4. Once assessment and measurement endpoints are agreed to by the risk assessor and risk manager, life history information for the species of concern or the surrogate species should be collected. Patterns of activity and feeding habits of a species affect their potential for exposure to a contaminant (e.g., grooming activities of small mammals, egestion of bone and hide by owls). Other important exposure factors include food and water ingestion rates, composition of the diet, average body weight, home range size, and seasonal activities such as migration.

Ecological effects profile. Once contaminants and species of concern are selected during problem formulation, a general overview of toxicity and toxic mechanisms is needed. The distinction between the species of concern representing an assessment endpoint and a surrogate species representing a measurement endpoint is important. The species of concern is the species that might be threatened by contaminants at the site. A surrogate species is used when it is not appropriate or possible to measure attributes of the species of concern. A surrogate for a species of concern should be sufficiently similar biologically to allow inferences on likely effects in the species of concern.

The ecological effects profile should include toxicity information from the literature for each possible exposure route. A lowest-observed-adverse-effect level (LOAEL) and the no-observed-adverse-effect level (NOAEL) for the species of concern or its surrogate should be obtained. Unfortunately, LOAELs are available for few wildlife species and contaminants. If used with caution, toxicity data from a closely related species can be used to estimate a LOAEL and a NOAEL for a receptor species.

C-2 INFORMATION SOURCES

This section describes information sources that can be examined to find the information described in Section 3-1. A logical and focused literature search will reduce the time spent searching for pertinent information.

A first step in a literature search is to develop a search strategy, including a list of key words. The next step is to review computerized databases, either on-line or CD-ROM-based information systems. These systems can be searched based on a number of parameters.

Scientific abstracts that contain up-to-date listings of current, published information also are useful information sources. Most abstracts are indexed by author or subject. Toxicity studies and information on wildlife life-histories often are summarized in literature reviews published in books or peer-reviewed journals. Original reports of toxicity studies can be identified in the literature section of published documents. The original article in which data are reported must be reviewed before the data are cited in a risk assessment.

Key words. Once the risk assessor has prepared a list of the specific information needed for the risk assessment, a list of key words can be developed. Card catalogs, abstracts, on-line databases, and other reference materials usually are indexed on a limited set of key words. Therefore, the key words used to search for information must be considered carefully.

Useful key words include the contaminant of concern, the biological species of concern, the type of toxicity information wanted, or other associated words. In addition, related subjects can be used as key words. However, it usually is necessary to limit peripheral aspects of the subject in order to narrow the search. For example, if the risk assessor needs information on the toxicity of lead in soils to moles, then requiring that both "lead" and "mole" are among the key words can focus the literature search. If the risk assessor needs information on a given plant or animal species (or group of species), key words should include both the scientific name (e.g., genus and species names or order or family names) and an accepted common name(s). The projected use of the data in the risk assessment helps determine which key words are most appropriate.

If someone outside of the risk assessment team will conduct the literature search, it is important that they understand both the key words and the study objectives for the data.

Databases. Databases are usually on-line or CD-ROM-based information systems. These systems can be searched using a number of parameters. Prior to searching databases, the risk assessor should determine which database(s) is most likely to provide the information needed for the risk assessment. For example, U.S. Environmental Protection Agency's (EPA's) AQUIRE database (AQUatic Information RETrieval database) provides information specifically on the toxicity of chemicals to aquatic plants and animals. PHYTOTOX includes data on the toxicity of contaminants to terrestrial and aquatic plants, and TERRETOX includes data on toxicity to terrestrial animals. U.S. EPA's IRIS (Integrated Risk Information System) provides information on human health risks (e.g., references to original toxicity studies) and regulatory information (e.g., reference doses and cancer potency factors) for a variety of chemicals. Other useful databases include the National Library of Medicine's HSDB (Hazardous Substances Data Bank) and the National Center for Environmental Assessment's HEAST Tables (Health Effects Assessment Summary Tables). Commercially

available databases include BIOSIS (Biosciences Information Services) and ENVIROLINE. Another database, the U.S. Public Health Service's Registry of Toxic Effects of Chemical Substances (RTECS) is a compilation of toxicity data extracted from the scientific literature and is also available online.

Several states have *Fish and Wildlife History Databases* or *Academy of Science* databases, which often provide useful information on the life-histories of plants and animals in the state. State databases are particularly useful for obtaining information on endemic organisms or geographically distinct habitats.

Databases searches can yield a large amount of information in a short period of time. Thus, if the key words do not accurately describe the information needed, database searches can provide a large amount of irrelevant information. Access fees and on-line fees can apply; therefore, the selection of relevant key words and an organized approach to the search will reduce the time and expense of on-line literature searches.

Abstracts. Published abstract compilations (e.g., Biological Abstracts, Chemical Abstracts, Applied Ecology Abstracts) contain up-to-date listings of current, published information. Most abstracts are indexed by author or subject. Authors and key words can be cross-referenced to identify additional publications. Abstract compilations also include, for each citation, a copy of its abstract from the journal or book in which it was published. Reviewing the abstracts of individual citations is a relatively quick way to determine whether an article is applicable to the risk assessment. As with computerized database searches, it is important to determine which abstract compilations are most suitable for the risk assessor's information needs.

Published abstract compilations that are indexed by author are particularly useful. If an author is known to conduct a specific type of research, their name would be referenced in the abstract for other articles on similar subjects. If the risk assessor considers an abstract pertinent to the assessment, the original article must be retrieved and reviewed before it can be cited in the risk assessment. Otherwise, the results of the risk assessment could be based on incorrect and incomplete information about a study.

Abstracts usually must be searched manually, which can be a very time consuming. The judicious use of key words can help to reduce the amount of time needed to search through these volumes.

Literature review publications. Published literature reviews often cover toxicity or wildlife information of value to an ecological risk assessment. For example, the U.S. Fish and Wildlife Services (U.S. FWS) has published several contaminant-specific documents that list toxicological data on terrestrial, aquatic, and avian studies (e.g., Eisler, 1988). The U.S. EPA publishes ambient water quality criteria documents (e.g., U.S. EPA, 1985) that list all the data used to calculate those values. Some literature reviews critically evaluate the original studies (e.g., toxicity data reviewed by NOAA, 1990). The *Wildlife Exposure Factors*

Handbook (U.S. EPA, 1993a,b) provides pertinent information on exposure factors (e.g., body weights, food ingestion rates, dietary composition, home range size) for 34 selected wildlife species.

Literature reviews can provide an extensive amount of information. However, the risk assessor must obtain a copy of the original of any studies identified in a literature review that will be used in the risk assessment. The original study must be reviewed and evaluated before it can be used in the risk assessment. Otherwise, the results of the risk assessment could be based on incorrect and incomplete information about a study.

References cited in previous studies. Pertinent studies can be identified in the literature cited section of published documents that are relevant to the risk assessment, and one often can identify several investigators who work on related studies. Searching for references in the literature cited section of published documents, however, takes time and might not be very effective. However, this is probably the most common approach to identifying relevant literature. If this approach is selected, the best place to start is a review article. Many journals do not list the title of a citation for an article, however, limiting the usefulness of this technique. Also, it can be difficult to retrieve literature cited in obscure or foreign journals or in unpublished masters' theses or doctoral dissertations. Although this approach tends to be more time consuming than the other literature search approaches described above, it probably is the most common approach used to locate information for a risk assessment.

Journal articles, books, government documents. There are a variety of journals, books, and government documents that contain information useful to risk assessments. The same requirement for retrieving the original reports for any information used in the risk assessment described for other information sources applies to these sources.

Threatened and endangered species. Threatened and endangered species are of concern to both federal and state governments. When conducting an ecological risk assessment, it often is necessary to determine or estimate the effects of site contaminants to federal threatened or endangered species. In addition, other special-status species (e.g., species listed by a state as endangered or threatened within the state) also can be the focus of the assessment. During the problem formulation step, the U.S. FWS or state Natural Heritage programs should be contacted to determine if these species are present or might be present on or near a Superfund site.

Once the presence of a special-status species is confirmed or considered likely, information on this species, as well as on surrogate species, should be included in the literature search. There are specific federal and state programs that deal with issues related to special-status species, and often there is more information available for these than for non-special-status species used as surrogates for an ecological risk assessment. Nonetheless, the use of surrogate species usually is necessary when an assessment endpoint is a special-status species.

REFERENCES

- Eisler, R. 1988. Lead Hazards to Fish, Wildlife, and Invertebrates: A Synoptic Review. U.S. Fish and Wildlife Service Patuxent Wildlife Research Center, Laurel MD: U.S. Department of the Interior; Biological Report 85(1.14), Contaminant Hazard Reviews Rep. No. 14.
- National Oceanic and Atmospheric Administration (NOAA). 1990. *The Potential for Biological Effects of Sediment-Sorbed Contaminants Tested in the National Status and Trends Program*. Seattle, WA: Office of Oceanography and Marine Assessment. NOAA/TM/NOS/OMA-52. Technical memorandum by Long, E.R. and Morgan, L.G.
- U.S. Environmental Protection Agency (U.S. EPA). 1993a. *Wildlife Exposure Factors Handbook Volume I*. Washington, DC: Office of Research and Development; EPA/600/R-93/187a.
- U.S. Environmental Protection Agency (U.S. EPA). 1993b. *Wildlife Exposure Factors Handbook Volume II: Appendix*. Washington, DC: Office of Research and Development; EPA/600/R-93/187b.
- U.S. Environmental Protection Agency (U.S. EPA). 1985. *Ambient Water Quality Criteria for Copper-1984*. Washington, DC: Office of Water, Regulations and Standards, Criteria and Standards Division. EPA/440/5-84-031. PB85-227023.

APPENDIX D
STATISTICAL CONSIDERATIONS

APPENDIX D

STATISTICAL CONSIDERATIONS

In the biological sciences, statistical tests often are needed to support decisions based on alternative hypotheses because of the natural variability in the systems under investigation. A statistical test examines a set of sample data, and, based on an expected distribution of the data, leads to a decision on whether to accept the hypothesis underlying the expected distribution or whether to reject that hypothesis and accept an alternative one. The null hypothesis is a hypothesis of no differences. It usually is formulated for the express purpose of being rejected. The alternative or test hypothesis is an operational statement of the investigator's research hypothesis. An example of a null hypothesis for toxicity testing would be that mortality of water fleas exposed to water from a contaminated area is no different than mortality of water fleas exposed to water from an otherwise similar, but uncontaminated area. An example of the test hypothesis is that mortality of water fleas exposed to water from the contaminated area is higher than mortality of water fleas exposed to uncontaminated water.

D-1 TYPE I AND TYPE II ERROR

There are two types of correct decisions for hypothesis testing: (1) accepting a true null hypothesis, and (2) rejecting a false null hypothesis. There also are two types of incorrect decisions: rejecting a true null hypothesis, called Type I error; and accepting a false null hypothesis, called Type II error.

When designing a test of a hypothesis, one should decide what magnitude of Type I error (rejection of a true null hypothesis) is acceptable. Even when sampling from a population of known parameters, there are always some sample sets which, by chance, differ markedly. If one allows 5 percent of samples to lead to a Type I error, then one would on average reject a true null hypothesis for 5 out of every 100 samples taken. In other words, we would be confident that, 95 times out of 100, one would not reject the null hypothesis of no difference "by mistake" (because chance alone produced such deviant results). When the probability of Type I error (commonly symbolized by α) is set at 0.05, this is called a significance level of 5 percent. Setting a significance level of 5 percent is a widely accepted convention in most experimental sciences, but it is just that, a convention. One can demand more confidence (e.g., $\alpha = 0.01$) or less confidence (e.g., $\alpha = 0.10$) that the hypothesis of no difference is not rejected by mistake.

If one requires more confidence for a given sample size that the null hypothesis is not rejected by mistake (e.g., $\alpha = 0.01$), the chances of Type II error increase. In other words, the chance increases that one will mistakenly accept a false null hypothesis (e.g., mistakenly

believe that the contaminated water from the site has no effect on mortality of water fleas). The probability of Type II error is commonly denoted by β . Thus:

$$p \text{ (Type I error)} = \alpha$$
$$p \text{ (Type II error)} = \beta$$

However, if one tries to evaluate the probability of Type II error (accepting a false hypothesis of no difference), there is a problem. If the null hypothesis is false, then some other hypothesis must be true, but unless one can specify a second hypothesis, one can't determine the probability of Type II error. This leads to another important statistical consideration, which is the power of a study design and the statistical test used to evaluate the results.

D-2 STATISTICAL POWER

The power of a statistical test is equal to $(1 - \beta)$ and is equal to the probability of rejecting the null hypothesis (no difference) when it should be rejected (i.e., it is false) and the specified alternative hypothesis is true. Obviously, for any given test (e.g., a toxicity test at a Superfund site), one would like the quantity $(1 - \beta)$ to be as large as possible (and β to be as small as possible). Because one generally cannot specify a given alternative hypothesis (e.g., mortality should be 40 percent in the exposed population), the power of a test is generally evaluated on the basis of a continuum of possible alternative hypotheses.

Ideally, one would specify both α and β before an experiment or test of the hypothesis is conducted. In practice, it is usual to specify α (e.g., 0.05) and the sample size because the exact alternative hypothesis cannot be specified.¹ Given the inverse relationship between the likelihood of making Type I and Type II errors, a decrease in α will increase β for any given sample size.

To improve the statistical power of a test (i.e., reduce β), while keeping α constant, one can either increase the sample size (N) or change the nature of the statistical test. Some statistical tests are more powerful than others, but it is important that the assumptions required by the test (e.g., normality of the underlying distribution) are met for the test results to be valid. In general, the more powerful tests rely on more assumptions about the data (see Section D-3).

Alternative study designs sometimes can improve statistical power (e.g., stratified random sampling compared with random sampling if something is known about the history and location of contaminant release). A discussion of different statistical sampling designs is beyond the scope of this guidance, however. Several references provide guidance on statistical sampling design, sampling techniques, and statistical analyses appropriate for hazardous waste sites (e.g., see Cochran, 1977; Green, 1979; Gilbert, 1987; Ott, 1995).

¹ With a specified alternative hypothesis, once α and the sample size (N) are set, β is determined.

One also can improve the power of a statistical test if the test hypothesis is more specific than "two populations are different," and, instead, predicts the direction of a difference (e.g., mortality in the exposed group is higher than mortality in the control group). When one can predict the direction of a difference between groups, one uses a one-tailed statistical test; otherwise, one must use the less powerful two-tailed version of the test.

Highlight D-2

Key Points About Statistical Significance, Power, and Sample Size

- (1) The significance level for a statistical test, α , is the probability that a statistical test will yield a value under which the null hypothesis will be rejected when it is in fact true. In other words, α defines the probability of committing Type I error (e.g., concluding that the site medium is toxic when it is in fact not toxic to the test organisms).
- (2) The value of β is the probability that a statistical test will yield a value under which the null hypothesis is accepted when it is in fact false. Thus, β defines the probability of committing Type II error (e.g., concluding that the site medium is not toxic when it is in fact toxic to the test organisms).
- (3) The power of a statistical test (i.e., $1 - \beta$) indicates the probability of rejecting the null hypotheses when it is false (and therefore should be rejected). Thus, one wants the power of a statistical test to be as high as possible.
- (4) Power is related to the nature of the statistical test chosen. A one-tailed test is more powerful than a two-tailed test. If the alternative to the null hypothesis can state the expected direction of a difference between a test and control group, one can use the more powerful one-tailed test.
- (5) The power of any statistical test increases with increasing sample size.

D-3 STATISTICAL MODEL

Associated with every statistical test is a model and a measurement requirement. Each statistical test is valid only under certain conditions. Sometimes, it is possible to test whether the conditions of a particular statistical model are met, but more often, one has to assume that they are or are not met based on an understanding of the underlying population and sampling design. The conditions that must be met for a statistical test to be valid often are referred to as the assumptions of the test.

The most powerful statistical tests (see previous section) are those with the most extensive assumptions. In general, parametric statistical tests (e.g., t test, F test) are the most powerful tests, but also have the most exacting assumptions to be met:

- (1) The "observations" must be independent;
- (2) The "observations" must be drawn from a population that is normally distributed;
- (3) The populations must have the same variance (or in special cases, a known ratio of variances); and
- (4) The variables must have been measured at least on an interval scale so that it is possible to use arithmetic operations (e.g., addition, multiplication) on the measured values (Siegel, 1956).

The second and third assumptions are the ones most often violated by the types of data associated with biological hypothesis testing. Often, distributions are positively skewed (i.e., longer upper than lower tail of the distribution). Sometimes, it is possible to transform data from positively skewed distributions to normal distributions using a mathematical function. For example, many biological parameters turn out to be log-normally distributed (i.e., if one takes the log of all measures, the resulting values are normally distributed). Sometimes, however, the underlying shape of the distribution cannot be normalized (e.g., it is bimodal).

When the assumptions required for parametric tests are not met, one must use nonparametric statistics (e.g., median test, chi-squared test). Nonparametric tests are in general less powerful than parametric tests because less is known or assumed about the shape of the underlying distributions. However, the loss in power can be compensated for by an increase in sample size, which is the concept behind measures of power-efficiency.

Power-efficiency reflects the increase in sample size necessary to make test B (e.g., a nonparametric test) as efficient or powerful as test A (e.g., a parametric test). A power-efficiency of 80 percent means that in order for test B to be as powerful as test A, one must make 10 observations for test B for every 8 observations for test A.

For further information on statistical tests, consult references on the topic (e.g., see references below).

REFERENCES

- Cochran, W. G. 1977. *Sampling Techniques. Third edition.* New York, NY: John Wiley and Sons, Inc.
- Gilbert, R.O. 1987. *Statistical Methods for Environmental Pollution Monitoring.* New York, NY: Reinhold.

- Green, R. H. 1979. *Sampling Design and Statistical Methods for Environmental Biologists*. New York, NY: Wiley.
- Ott, W.R. 1995. *Environmental Statistics and Data Analysis*. Boca Raton, FL: CRC Press, Inc., Lewis Publishers.
- Siegel, S. 1956. *Non-parametric Statistics*. New York, NY: McGraw-Hill.