

United States
Environmental Protection
Agency

Office of Emergency
Remedial Response
Washington, DC 20460

EPA/540/P-91/001
February 1991

Superfund



Conducting Remedial Investigations/Feasibility Studies for CERCLA Municipal Landfill Sites

EPA/540/P-91/001
OSWER Directive 9355.3-11
February 1991

**Conducting Remedial Investigations/
Feasibility Studies for CERCLA
Municipal Landfill Sites**

Office of Emergency and Remedial Response
U.S. Environmental Protection Agency
Washington, D.C. 20460

NOTICE

Development of this document was funded by the United States Environmental Protection Agency. It has been subjected to the Agency's review process and approved for publication as an EPA document.

The policies and procedures set out in this document are intended solely for the guidance of response personnel. They are not intended, nor can they be relied upon, to create any rights, substantive or procedural, enforceable by any party in litigation with the United States. EPA officials may decide to follow this guidance, or to act variance with these policies and procedures based on an analysis of specific site circumstances, and to change them at any time without public notice.

CONTENTS

	Page
GLOSSARY	viii
ES EXECUTIVE SUMMARY	ES-1
1 INTRODUCTION	1-1
1.1 Background on Municipal Landfills	1-2
1.2 Document Organization	1-3
2 SCOPING THE RI/FS FOR MUNICIPAL LANDFILL SITES	2-1
2.1 Evaluation of Existing Data	2-2
2.1.1 Sources of Information	2-2
2.1.2 Types of Data and Data Quality	2-3
2.1.3 Presentation of Available Data	2-4
2.2 Existing Data Evaluation Results and Report	2-4
2.2.1 Site Description	2-6
2.2.2 Site History	2-7
2.2.3 Regional and Site Geology and Hydrogeology	2-7
2.2.4 Hydrology	2-9
2.2.4.1 Surface Water	2-9
2.2.4.2 Groundwater	2-9
2.2.5 Waste Characterization	2-9
2.2.6 Sampling Activities and Results	2-10
2.3 Site Visit	2-10
2.4 Limited Field Investigation	2-12
2.5 Conceptual Site Model	2-15
2.6 Risk Assessment	2-18
2.7 Preliminary Remedial Action Objectives and Goals	2-19
2.8 Preliminary Remedial Technologies	2-20
2.8.1 Development of Preliminary Remedial Action Alternatives	2-20
2.8.2 Review of Remedial Technologies in CERCLA Landfill RODs	2-21
2.9 Objectives of the RI/FS	2-23
2.10 Development of DQOs	2-31
2.11 Section 2 Summary	2-39
3 SITE CHARACTERIZATION STRATEGIES	3-1
3.1 Groundwater	3-2
3.1.1 Groundwater Investigations	3-2
3.1.1.1 Phase I Site Characterization	3-2
3.1.1.2 Phase II Site Characterization	3-4
3.1.2 Data Requirements	3-4
3.1.3 Placement of Monitoring Wells	3-5
3.1.3.1 Objectives	3-5
3.1.3.2 Procedures	3-5
3.1.3.3 Guidelines	3-7
3.1.4 Groundwater Summary	3-7

CONTENTS

	Page
3.2 Leachate	3-7
3.2.1 Leachate, Investigations	3-10
3.2.1.1 Objectives	3-10
3.2.1.2 Procedures	3-10
3.2.1.3 Guidelines	3-12
3.2.2 Data Requirements	3-12
3.2.3 Leachate Summary	3-13
3.3 Landfill Contents/Hot Spots	3-13
3.3.1 Landfill Contents/Hot Spot Investigations	3-13
3.3.1.1 Objectives	3-15
3.3.1.2 Procedures	3-17
3.3.1.3 Guidelines	3-24
3.3.2 Data Requirements	3-25
3.3.3 Landfill Contents/Hot Spots Summary	3-25
3.4 Landfill Gas	3-25
3.4.1 Landfill Gas Investigations	3-25
3.4.1.1 Objectives	3-25
3.4.1.2 Procedures	3-27
3.4.1.3 Guidelines	3-28
3.4.2 Data Requirements	3-28
3.4.3 Landfill Gas Summary	3-29
3.5 Wetlands and Sensitive Environments	3-29
3.5.1 Wetlands and Sensitive Environment Evaluation	3-29
3.5.1.1 Objectives	3-31
3.5.1.2 Procedures	3-31
3.5.1.3 Guidelines	3-31
3.5.2 Data Requirements	3-32
3.5.3 Wetlands Summary	3-32
3.6 Surface Water	3-34
3.6.1 Surface Water Investigation	3-34
3.6.1.1 Objectives	3-34
3.6.1.2 Procedures	3-34
3.6.1.3 Guidelines	3-36
3.6.2 Data Requirements	3-36
3.6.3 Surface Water Summary	3-36
3.7 Baseline Risk Assessment	3-37
3.7.1 Components of the Baseline Risk Assessment	3-37
3.7.1.1 Contaminant Identification	3-37
3.7.1.2 Exposure Assessment	3-39
3.7.1.3 Toxicity Assessment	3-39
3.7.1.4 Risk Characterization	3-39
3.7.2 Using the Baseline Risk Assessment to Streamline Remedial Action Decisions	3-39
3.8 Section 3 Summary	3-40
4 DETAILED DESCRIPTION OF TECHNOLOGIES	4-1
4.1 Remedial Action Objectives	4-1
4.2 Landfill Contents	4-2
4.2.1 Access Restrictions	4-2
4.2.1.1 Deed Restrictions	4-3
4.2.1.2 Fencing	4-3

CONTENTS

	Page
4.2.2	Containment 4-3
4.2.2.1	Surface Controls 4-3
4.2.2.2	Cap (Landfill Cover) 4-6
4.2.3	Removal/Disposal 4-12
4.2.3.1	Excavation (Hot Spots) 4-12
4.2.3.2	Consolidation 4-14
4.2.3.3	Disposal Offsite (Hot Spots) 4-14
4.2.4	Hot Spots Treatment 4-15
4.2.4.1	Thermal Treatment (Onsite) 4-16
4.2.4.2	Stabilization 4-17
4.2.5	Innovative Treatment Technologies 4-18
4.2.5.1	Description of Technologies 4-18
4.2.6	References 4-19
4.3	Leachate 4-21
4.3.1	Collection of Leachate 4-21
4.3.1.1	Subsurface Drains 4-21
4.3.1.2	Vertical Extraction Wells 4-21
4.3.2	Treatment of Leachate 4-22
4.3.2.1	Onsite Treatment 4-23
4.3.2.2	Offsite Treatment 4-25
4.3.3	References 4-27
4.4	Landfill Gas 4-28
4.4.1	Collection of Landfill Gas 4-28
4.4.1.1	Passive Systems 4-28
4.4.1.2	Active Systems 4-29
4.4.2	Treatment of Landfill Gas 4-30
4.4.2.1	Thermal Treatment (Enclosed Ground Flares) 4-30
4.4.3	References 4-32
4.5	Groundwater 4-32
4.5.1	Collection, Treatment, and Disposal 4-32
4.5.2	Containment 4-32
4.5.2.1	Vertical Barriers (Slurry Walls) 4-32
4.5.3	References 4-34
4.6	Wetlands 4-35
4.6.1	Removal or Management of Wetlands Sediments 4-35
4.6.2	Mitigating Wetlands Losses 4-35
4.6.3	References 4-36
4.7	Surface Water and Sediments 4-36
4.7.1	Treatment of Surface Water 4-36
4.7.2	Removal and Management of Sediments 4-36
4.7.3	References 4-37
4.8	Section 4 Summary 4-37
5	EVALUATION CRITERIA 5-1
5.1	Overall Protection of Human Health and the Environment 5-2
5.2	Compliance with ARARs 5-6
5.2.1	Federal ARARs 5-6
5.2.1.1	Chemical-Specific ARARs 5-6
5.2.1.2	Location-Specific ARARs 5-23
5.2.1.3	Action-Specific ARARs 5-24

CONTENTS

	Page
5.2.2 State ARARs	5-25
5.2.2.1 Chemical-Specific ARARs	5-26
5.2.2.2 Location-Specific ARARs	5-26
5.2.2.3 Action-Specific ARARs	5-26
5.3 Long-Term Effectiveness and Permanence	5-27
5.4 Reduction of TMV Through Treatment	5-27
5.5 Short-Term Effectiveness	5-27
5.6 Implementability	5-27
5.7 Cost	5-28
5.8 State Acceptance	5-28
5.9 Community Acceptance	5-28
5.10 Section 5 Summary	5-28
6 DEVELOPMENT AND EVALUATION OF ALTERNATIVES FOR THE EXAMPLE SITE	6-1
6.1 Example Site ARARs	6-8
6.1.1 Chemical-Specific ARARs	6-8
6.1.1.1 Groundwater	6-8
6.1.1.2 Surface Water	6-8
6.1.2 Location-Specific ARARs	6-8
6.1.3 Action-Specific ARARs	6-8
6.1.3.1 Soils/Landfill Contents	6-8
6.2 Development of Alternatives	6-8
6.2.1 Alternative 1--No Action Alternative	6-9
6.2.2 Alternative 2	6-9
6.2.3 Alternative 3	6-10
6.2.4 Alternative 4	6-11
6.3 Comparative Analysis of Alternatives	6-12
6.3.1 Overall Protection of Human Health and the Environment	6-12
6.3.2 Compliance with ARARs	6-12
6.3.3 Short-Term Effectiveness	6-12
6.3.4 Long-Term Effectiveness	6-13
6.3.5 Reduction of Toxicity, Mobility, and Volume Through Treatment	6-13
6.3.6 Implementability	6-14
6.3.7 Costs	6-14
6.4 Section 6 Summary	6-14
7 BIBLIOGRAPHY	7-1
Appendix A Site Characterization Strategy for an Example Site	
Appendix B Remedial Technologies Used at Landfill Sites	

TABLES

	Page
2-1	Limited Field Investigation Options for Municipal Landfill Sites 2-13
2-2	Preliminary Identification of Remedial Action Objectives for Media of Concern at Municipal Landfill Sites 2-20
2-3	Remedial Actions Used at Landfill Sites 2-24
2-4	Phase I Remedial Investigation Objectives for Municipal Landfill Sites 2-32
2-5	Phase II Remedial Investigation Objectives for Municipal Landfill Sites 2-36
3-1	Conditions That Determine Monitoring Well Location and Numbers 3-8
3-2	Range of Typical Domestic Refuse Leachate Constituent Concentrations 3-11
3-3	Leachate Sampling Program 3-13
3-4	Summary of Sampling Requirements for Soil and Landfill Contents 3-27
3-5	Landfill Gas Sampling Program 3-29
3-6	Summary of Sampling Requirements for Environmental Evaluation 3-32
3-7	Sampling and Monitoring Rationale for Surface Water and Sediments Near Municipal Landfill Sites 3-36
5-1	Evaluation of Technologies Frequently Used at Municipal Landfills 5-3
5-2	Potential Federal Location-Specific ARARs for Municipal Landfill Sites 5-7
5-3	Potential Federal Action-Specific ARARs for Municipal Landfill Sites 5-9
6-1	Recommended Alternatives: Summary of Detailed Analysis (Example Site) 6-2
B-1	RODs Reviewed for Municipal Landfill Study B-1
B-2	Remedial Technologies Used at Landfill Sites B-6
B-3	Breakdown by Region of Remedial Technologies Used at Landfill Sites B-36

FIGURES

2-1	Flow Diagram for Data Evaluation and Preparation 2-5
2-2	Typical Soil/Geologic Cross Section of Municipal Landfill and Adjacent Areas 2-8
2-3	Schematic of Conceptual Landfill Site 2-16
2-4	Potential Conceptual Site Model for Municipal Landfills 2-17
2-5	Identification of Remedial Technologies 2-22
3-1	Logic Diagram for Monitoring Well and Screen Placement 3-9
3-2	Logic Diagram for Leachate Sampling 3-14
3-3	Logic Diagram for Soils/Landfill Contents Sampling 3-26
3-4	Logic Diagram for Landfill Gas Sampling 3-30
3-5	Logic Diagram for Environmental Assessment Near Municipal Landfills 3-33
3-6	Logic Diagram for Surface Water/Sediment Sampling Near Municipal Landfill 3-38
4-1	Landfill Cover Selection Guide 4-7

GLOSSARY OF ACRONYMS AND ABBREVIATIONS

ARAR	Applicable or relevant and appropriate requirement
BOD	Biochemical oxygen demand
BTU	British thermal unit
CAA	Clean Air Act
CERCLA	Comprehensive Environmental Response, Compensation and Liability Act
CLP	Contract laboratory program
COD	Chemical oxygen demand
CRP	Community relations plan
CWA	Clean Water Act
DNAPL	Dense, nonaqueous-phase liquid
DQO	Data quality objective
EMSL	Environmental Monitoring Systems Laboratory
EPA	U.S. Environmental Protection Agency
FIT	Field Investigation Team
FML	Flexible membrane liner
FS	Feasibility study
FSP	Field Sampling Plan
FWQC	Federal Water Quality Criteria
GAC	Granular activated carbon
GC	Gas chromatography
GPR	Ground penetrating radar
HDPE	High density polyethelene
HRS	Hazard ranking system
HSP	Health and safety plan
LDR	Land Disposal Restrictions
LFG	Landfill gas
LFI	Limited field investigation
MCL	Maximum contaminant levels
MCLG	Maximum contaminant level goals
NCC	National Climatic Center
NCP	National Contingency Plan
NPDES	National Pollutant Discharge Elimination System
NPL	National Priorities List
O&M	Operations and maintenance
OVA	Organic vapor analyzer
PARCC	Precision, accuracy, representativeness, completeness, comparability
PA/SI	Preliminary assessment/site inspection
PCB	Polychlorinated byphenyl
PIC	Products of incomplete combustion
PID	Photoionization detector
POTW	Publicly owned treatment works

ppb	Parts per billion
ppm	Parts per million
PRP	Potentially responsible party
PVC	Poly vinyl chloride
QAPP	Quality assurance project plan
QA/QC	Quality assurance/quality control
RCRA	Resource Conservation and Recovery Act
RD/RA	Remedial design/remedial action
RI	Remedial investigation
ROD	Record of decision
RPM	Remedial project manager
SAP	Sampling and analysis plan
SDWA	Safe Drinking Water Act
SOW	Scope of work
SVE	Soil vapor extraction
TAL	Target analyte list
TBC	To be considered
TCE	Trichloroethene
TCL	Target compound list
TCPL	Toxicity characteristic leaching procedure
TDS	Total dissolved solids
TMV	Toxicity, mobility, and volume
TOC	Total organic carbon
TSDf	Treatment, storage, and disposal facility
TSS	Total suspended solids
USGS	U.S. Geological Survey
VC	Vinyl chloride
VOC	Volatile organic compound

ACKNOWLEDGEMENTS

This document was developed by EPA's Office of Emergency and Remedial Response with assistance provided by CH2M HILL in partial fulfillment of Contract No. 68-W8-0098. Susan Cange served as EPA project manager. The CH2M HILL project team was headed by John Rendall and included Amelia Janisz, Sadia Kissoon, Dave Bunte, Fouad Arbid, Gayle Lytle, and Pat Trate.

In addition to the many EPA Headquarters personnel who assisted in this effort, the following regional, state, and contractor representatives provided significant contributions to the preparation of this document:

Wayne Robinson	EPA, Region I
Edward Als Sherrel Henry Caroline Kwan	EPA, Region II
Fran Costanzi Mindi Snoparsky	EPA, Region III
Fred Bartman Dion Novak Robert Swale	EPA, Region V
Steve Veale	EPA, Region VI
Gwen Hooten	EPA, Region VIII
Brian Ullensvang	EPA, Region IX
Mary Jane Nearman Debbie Yamamoto	EPA, Region X
Thomas J. Cozzi	State of New Jersey Department of Environment Protection
Peter Kmet	State of Washington Department of Ecology
Celia VanDerloop	State of Wisconsin Department of Natural Resources
Alan Felser	Ebasco
Phil Smith	CH2M HILL
Bill Swanson	CDM/FPC

EXECUTIVE SUMMARY

A broad framework for the Remedial Investigation/Feasibility Study (RI/FS) and selection of remedy process has been created through the National Contingency Plan (NCP) and the *U.S. EPA RI/FS Guidance* (U.S. EPA, 1988d). With this framework now in place, the Office of Emergency and Remedial Response's efforts are being focused on streamlining the RI/FS and selection of remedy process for specific classes of sites with similar characteristics. One such class of sites is the municipal landfills which compose approximately 20 percent of the sites on the Superfund Program's National Priorities List (NPL). Landfill sites currently on the NPL typically contain a combination of principally municipal and to a lesser extent hazardous waste and range in size from 1 acre to 640 acres. Potential threats to human health and the environment resulting from municipal landfills may include:

- Leachate generation and groundwater contamination
- Soil contamination
- Landfill contents
- Landfill gas
- Contamination of surface waters, sediments, and adjacent wetlands

Because these sites share similar characteristics, they lend themselves to remediation by similar technologies. The NCP contains the expectation that containment technologies will generally be appropriate remedies for wastes that pose a relatively low low-level threat or where treatment is impracticable. Containment has been identified as the most likely response action at these sites because (1) CERCLA municipal landfills are primarily composed of municipal, and to a lesser extent hazardous wastes; therefore, they often pose a low-level threat rather than a principal threat; and (2) the volume and heterogeneity of waste within CERCLA municipal landfills will often make treatment impractical. The NCP also contains an expectation that treatment should be

considered for identifiable areas of highly toxic and/or mobile material (hot spots) that pose potential principal threats. Treatment of hot spots within a landfill will therefore be considered and evaluated.

With these expectations in mind, a study of municipal landfills was conducted with the intent of developing methodologies and tools to assist in streamlining the RI/FS and selection of remedy process. Streamlining may be viewed as a mechanism to enhance the efficiency and effectiveness of decision-making at these sites. The goals of this study to meet this objective include: (1) developing tools to assist in scoping the RI/FS for municipal landfill sites, (2) defining strategies for characterizing municipal landfill sites that are on the NPL, and (3) identifying practicable remedial action alternatives for addressing these types of sites.

Streamlining Scoping

The primary purpose of scoping an RI/FS is to divide the broad project goals into manageable tasks that can be performed within a reasonable period of time. The broad project goals of any Superfund site are to provide the information necessary to characterize the site, define site dynamics, define risks, and develop a remedial program to mitigate current and potential threats to human health and the environment. Scoping of municipal landfill sites can be streamlined by focusing the RI/FS tasks on just the data required to evaluate alternatives that are most practicable for municipal landfill sites. Section 2 of this document describes the activities that must take place to plan an RI/FS and provides guidelines for establishing a project's scope. To summarize, scoping of the RI/FS tasks can be streamlined by:

- Developing preliminary remedial objectives and alternatives based on the NCP expectations and focusing on alternatives successfully implemented at other sites
- Using a conceptual site model (see Figure 2-4 for a generic model devel-

- oped for municipal landfill sites based on their similarities) to help define site conditions and to scope future field tasks
- Conducting limited field investigations to assist in targeting future fieldwork
- Identifying clear, concise RI objectives in the form of field tasks to ensure sufficient data are collected to adequately characterize the site, perform the necessary risk assessment(s), and evaluate the practicable remedial action alternatives
- Identifying data quality objectives (DQOs) that result in a well-defined sampling and analysis plan, ensure the quality of the data collected, and integrate the information required in the RI/FS process
- Limiting the scope of the baseline risk assessment as discussed below

Streamlining the Baseline Risk Assessment

The baseline risk assessment may be used to determine whether a site poses risks to human health and the environment that are significant enough to warrant remedial action. Because options for remedial action at municipal landfill sites are limited, it may be possible to streamline or limit the scope of the baseline risk assessment by (1) using the conceptual site model and RI-generated data to perform a qualitative risk assessment that identifies the contaminants of concern in the affected media, their concentrations, and their hazardous properties that may pose a risk through the various routes of exposure and (2) identifying pathways that are an obvious threat to human health or the environment by comparing RI-derived contaminant concentration levels to standards that are potential chemical-specific applicable or relevant and appropriate requirements (ARARs) for the action. (When potential ARARs do not exist for a specific contaminant, risk-based chemical concentrations should be used.)

Where established standards for one or more contaminants in a given medium are clearly exceeded, the basis for taking remedial action is

generally warranted (quantitative assessments that consider all chemicals, their potential additive effects, or additivity of multiple exposure pathways are not necessary to initiate remedial action). In cases where standards are not clearly exceeded, a more thorough risk assessment may be necessary before initiating remedial action.

This streamlined approach may facilitate early action on the most obvious landfill problems (groundwater and leachate, landfill gas, and the landfill contents) while analysis continues on other problems such as affected wetlands and stream sediments. Dividing a site into operable units and performing early or interim actions is often desirable for these types of sites. This is because performing certain early actions (e.g., capping a landfill) can reduce the impact to other parts of a site while the RI/FS continues. Additionally, early actions must be consistent with the site's final remedy and therefore help to speed up the clean-up process.

Ultimately, it will be necessary to demonstrate that the final remedy, once implemented, will in fact address all pathways and contaminants of concern, not just those that triggered the remedial action. The approach outlined above facilitates rapid implementation of protective remedial measures for the major problems at a municipal landfill site.

Streamlining Site Characterization

Site characterization for municipal landfills can be expedited by focusing field activities on the information needed to sufficiently assess risks posed by the site, and to evaluate practicable remedial actions. Recommendations to help streamline site characterization of media typically affected by landfills are discussed in Section 3 of this report. A summary of the site characterization strategies is presented below.

Leachate/Groundwater Contamination

Characterization of a site's geology and hydrogeology will affect decisions on capping options as well as on extraction and treatment systems for leachate and groundwater. Data gathered during the hydrogeologic investigation are similar to those gathered during investigations at

other types of NPL sites. Groundwater contamination at municipal landfill sites may, however, vary in composition from that at other types of sites in that it often contains high levels of organic matter and metals.

Leachate generation is of special concern when characterizing municipal landfill sites. The main factors contributing to leachate quantity are precipitation and recharge from groundwater and surface water. Leachate is characteristically high in organic matter as measured by chemical oxygen demand (COD) or biochemical oxygen demand (BOD). In many landfills, leachate is perched within the landfill contents, above the water table. Placing a limited number of leachate wells in the landfill is an efficient means of gathering information regarding the depth, thickness, and types of the waste; the moisture content and degree of decomposition of the waste; leachate head levels and the composition of landfill leachate; and the elevation of the underlying natural soil layer. Additionally, leachate wells provide good locations for landfill gas sampling. It should be noted, however, that without the proper precautions, placing wells into the landfill contents may create health and safety risks. Also, installation of wells through the landfill base may create conduits through which leachate can migrate to lower geologic strata, and the installation of wells into landfill contents may make it difficult to ensure the reliability of the sampling locations.

Landfill Contents

Characterization of a landfill's contents is generally not necessary because containment of the landfill contents, which is often the most practicable technology, does not require such information. Certain data, however, are necessary to evaluate capping alternatives and should be collected in the field. For instance, certain landfill properties such as the fill thickness, lateral extent, and age will influence landfill settlement and gas generation rates, which will thereby have an influence on the cover type at a site. Also, characterization of a landfill's contents may provide valuable information for PRP determination. A records review can also be valuable in gathering data concerning disposal history, thus reducing the need for field sampling of contents.

Hot Spots

More extensive characterization activities and development of remedial alternatives (such as thermal treatment or stabilization) may be appropriate for hot spots. Hot spots consist of highly toxic and/or highly mobile material and present a potential principal threat to human health or the environment. Excavation or treatment of hot spots is generally practicable where the waste type or mixture of wastes is in a discrete, accessible location of a landfill. A hot spot should be large enough that its remediation would significantly reduce the risk posed by the overall site, but small enough that it is reasonable to consider removal or treatment. It may generally be appropriate to consider excavation and/or treatment of the contents of a landfill where a low to moderate volume of toxic/mobile waste (for example, 100,000 cubic yards or less) poses a principal threat to human health and the environment.

Hot spots should be characterized if documentation and/or physical evidence exists to indicate the presence and approximate location of the hot spots. Hot spots may be delineated using geophysical techniques or soil gas surveys and typically are confirmed by excavating test pits or drilling exploratory borings. When characterizing hot spots, soil samples should be collected to determine the waste characteristics; treatability or pilot testing may be required to evaluate treatment alternatives.

Landfill Gas

Several gases typically are generated by decomposition of organic materials in a landfill. The composition, quantity, and generation rates of the gases depend on such factors as refuse quantity and composition, placement characteristics, landfill depth, refuse moisture content, and amount of oxygen present. The principal gases generated (by volume) are carbon dioxide, methane, trace thiols, and occasionally, hydrogen sulfide. Volatile organic compounds may also be present in landfill gases, particularly at co-disposal facilities. Data generated during the site characterization of landfill gas should include landfill gas characteristics as well as the role of onsite and offsite surface emissions, and the geologic and hydrogeologic conditions of the site.

Streamlining the Development of Alternatives

Section 4 of this document describes the remedial technologies that are generally appropriate to CERCLA landfill sites. Inclusion of these technologies is based on experience at landfill sites and expectations inherent in the NCP. To streamline the development of remedial action alternatives for landfill contents, hot spots, landfill gas, contaminated groundwater, and leachate, the following points should be considered:

- The most practicable remedial alternative for landfills is containment. Such containment may be achieved by installing a cap to prevent vertical infiltration of surface water. Lateral infiltration of water or gases into the landfill can be prevented by a perimeter trench-type barrier. Caps and perimeter barriers sometimes are used in combination. The type of cap would likely be either a native soil cover, single-barrier cap, or composite-barrier cap. The appropriate type of cap to be considered will be based on remedial objectives for the site. For example, a soil cover may be sufficient if the primary objective is to prevent direct contact and minimize erosion. A single barrier or composite cap may be necessary where infiltration is also a significant concern. Similarly, the type of trench will be dependent on the nature of the contaminant to be contained. Impermeable trenches may be constructed to contain liquids while permeable trenches may be used to collect gases. Compliance with ARARs may also affect the type of containment system to be considered.
- Treatment of soils and wastes may be practicable for hot spots. Consolidation of hot spot materials under a landfill cap is a potential alternative in cases when treatment is not practicable or necessary. Consolidation-related differential settlements may be large enough to require placement of an interim cap during the consolidation phase. Once the rate of settlement is observed to decrease, then a

final cap can be placed over the waste.

- Extraction and treatment of contaminated groundwater and leachate may be required to control offsite migration of wastes. Additionally, extraction and treatment of leachate from landfill contents may be required. Collection and treatment may be necessary indefinitely because of continued contaminant loadings from the landfill.
- Constructing an active landfill gas collection and treatment system should be considered where (1) existing or planned homes or buildings may be adversely affected through either explosion or inhalation hazards, (2) final use of the site includes allowing public access, (3) the landfill produces excessive odors, or (4) it is necessary to comply with ARARs. Most landfills will require at least a passive gas collection system (that is, venting) to prevent buildup of pressure below the cap and to prevent damage to the vegetative cover.

Conclusions

Evaluation and selection of appropriate remedial action alternatives for CERCLA municipal landfill sites is a function of a number of factors including:

- Sources and pathways of potential risks to human health and the environment
- Potential ARARs for the site (Significant ARARs might include RCRA and/or state closure requirements, and federal or state requirements pertaining to landfill gas emissions.)
- Waste characteristics
- Site characteristics (including surrounding area)
- Regional surface water (including wetlands) and groundwater characteristics and potential uses

Because these factors are similar for many CERCLA municipal landfill sites, it is possible to focus the RI/FS and selection of remedy process. In general, the remedial actions implemented at most CERCLA municipal landfill sites include:

- Containment of landfill contents (i.e., landfill cap)

- Remediation of hot spots
- Control and treatment of contaminated groundwater and leachate
- Control and treatment of landfill gas

Other areas that may require remediation include surface waters, sediments, and adjacent wetlands.

Section 1

INTRODUCTION

Approximately 20 percent of the sites on the National Priorities List (NPL) are landfills where a combination of principally municipal and to a lesser extent hazardous wastes have been co-disposed. Because these sites typically share similar characteristics, the Superfund Program anticipates that their remediation will involve similar waste management approaches.

EPA has established a number of expectations pertaining to the remediation of CERCLA sites and has listed them in the National Contingency Plan (NCP). One of these expectations, which is particularly relevant to municipal landfills, states that engineering controls such as containment will be used for waste that poses a relatively low long-term threat or for sites where treatment is impracticable. The preamble to the NCP identifies municipal landfills as a type of site where treatment may be impracticable due to the size and heterogeneity of the contents of many landfills. Because of this expectation, the containment alternative should be developed in the detailed analysis, and will often be the appropriate response action for CERCLA municipal landfill sites based on the nine criteria. However, other alternatives such as leachate recirculation or “flushing” of landfill contents may be appropriate for certain situations and if determined to be practicable should not be discounted.

A second NCP expectation states that principal threats (e.g., highly mobile and/or highly toxic waste) will be treated, if practicable. Treatment of hot spots within a landfill may be considered practicable when: (1) wastes are in discrete, accessible locations of a landfill and present a potential principal threat to human health and the environment and (2) a hot spot is large enough that its remediation will significantly reduce the risk posed by the site, but small enough that it is reasonable to consider removal and/or treatment. Characterization of hot spots to determine if treatment is practicable should be performed when there is either documentation or physical evidence (e.g., aerial photographs) indicating the approximate location of hot spots.

Other expectations in the NCP that may be relevant to the remediation of municipal landfills are summarized below.

- A combination of engineering controls and treatment will be used as appropriate to achieve protection of human health and the environment. An example would include treatment of hot spots in conjunction with containment (capping) of the landfill contents.
- Institutional controls such as access and deed restrictions will be used to supplement engineering controls as appropriate, to prevent exposure to hazardous wastes.
- Groundwaters will be returned to beneficial uses whenever practical, within a reasonable time, given the particular circumstances of the site.
- Innovative technologies will be considered when such technologies offer the potential for superior treatment performance or lower costs for performance similar to that of demonstrated technologies.

The similarity in landfill characteristics and the NCP expectations make it possible to streamline the RI/FS process for municipal landfills. By streamlining the RI/FS process EPA will (1) improve the efficiency and effectiveness of decision making at these sites; (2) provide for consistency among the Regions in their approach to conducting an RI/FS and selecting remedial actions, and (3) facilitate more effective remedial designs.

In direct response to the need to develop tools and methodologies to streamline the RI/FS process for different site types (Recommendation No. 23 in the Superfund Management Review Implementation Plan), the Office of Emergency and Remedial Response has developed this document which (1) provides information and tools to assist in scoping an RI/FS,

(2) defines appropriate strategies for characterizing media typically impacted by municipal landfills, (3) identifies a strategy for simplifying the baseline risk assessment (thereby allowing for early action at these sites), and (4) identifies the most practicable remedial action alternatives for addressing these types of sites.

1.1 Background On Municipal Landfills

CERCLA municipal landfill sites are unique in both their size and composition. The landfills currently on the NPL range in size from 1 acre to 640 acres, while most are facilities where a combination of principally municipal and to a lesser extent hazardous wastes have been codisposed of. Municipal wastes disposed of in these landfills typically includes a heterogeneous mixture of materials primarily composed of household refuse such as yard and food wastes and paper, and commercial waste such as plastics, inert mineral waste, glass, and metals. There are four ways in which hazardous wastes may have been disposed of in municipal landfills. First, landfills that operated before the implementation of RCRA on November 19, 1980, typically accepted and co-disposed of both liquid and solid hazardous waste. Second, small quantity generators contribute varying quantities of hazardous wastes to municipal landfills. Small quantity generators are those that produce no more than one kilogram per month of designated acute hazardous waste or no more than 100 kilograms per month of all other hazardous wastes combined (see 40 CFR 261.5). Third, some household wastes such as batteries and paints are hazardous. And fourth, biodegradation of wastes within the landfill can create new compounds that are hazardous.

The dynamics within a landfill create an unknown and changing environment. Microbial degradation of the municipal solid waste occurs, in addition to various unknown interactions between hazardous and municipal solid wastes. Microbial degradation of municipal solid waste is a dynamic process that occurs for an indefinite period of time after waste has been placed within a landfill. Microorganisms naturally occurring in the soil and refuse biodegrade the wastes in distinct stages; each stage of

degradation creates different byproducts.

Landfills can react with the environment in a number of ways. One type of interaction occurs when precipitation and/or liquid wastes disposed of within the landfill percolate through the landfilled mass to form a liquid called leachate. Leachate may enter the subsurface soils and groundwater or be discharged to nearby surface waters and wetlands from groundwater or seeps. The amount of leachate formed from a landfill is a function of (1) the amount of precipitation in the area, (2) the types of materials disposed of in the landfill, (3) the design, size, age, and initial moisture content of the landfill, and (4) the permeability and porosity of landfilled materials and the soil used to cover the landfill. The characteristics of landfill leachate depend upon factors such as initial concentrations of compounds, solubilities, and vapor pressures, rates at which compounds are transformed by microbial and chemical processes within the landfill, and the physical characteristics of the landfilled materials. The transport and fate of leachate in the subsurface environment is a function of the landfill design and the characteristics of the underlying soil types.

A second way in which landfills can interact with the environment is through discharge to nearby surface waters and wetlands. As mentioned previously, leachate may be discharged from seeps to local surface waters and wetlands or contaminated groundwaters may recharge these media. The most direct contribution however, is often through stormwater runoff. Runoff from a landfill may be voluminous but the contact time with the landfill materials is often limited.

A third type of interaction between landfills and the environment is through airborne emissions of gases and vapors. Some of the volatile compounds emitted from landfills are those present in the landfill as it is being filled, while others are generated by microorganisms as they degrade the wastes in the landfill. The principal airborne emissions (by volume) associated with landfills are methane and carbon dioxide. These gases are the result of anaerobic microbial degradation of municipal solid wastes. Other volatile compounds often emitted from

CERCLA landfills include halogenated hydrocarbons, simple alkanes, vinyl chloride, benzene and other aromatic compounds, and merceptons. The principal factors affecting the type of air emissions include (1) the type of materials disposed of in the landfill, (2) the age of the landfilled refuse, (3) the type of cover overlaying the landfilled wastes, (4) the presence or absence of a gas extraction and treatment system, (5) subsurface gas migration, and (6) the presence of underground/subsurface fires. Barometric pressure and wind speed and direction also play an important role in the affects to potential receptors.

1.2 Document Organization

This document is organized into six sections. The first section is this introduction, which includes the goals and objectives of this project as well as a summary of municipal landfill characteristics and their potential impact on the environment. Section 2 describes the activities necessary to adequately scope an RI/FS for a landfill site and provides a number of tools to assist in scoping. The third section describes site characterization strategies for co-disposal facilities that either have or do not have

suspected hot spots. Section 4 of this report describes the remedial technologies that are appropriate for CERCLA landfills, including the data requirements to adequately evaluate them. Section 5 includes an analysis of the nine criteria used to evaluate practicable technologies and summarizes basic conclusions that can be made for each technology in light of each of the evaluation criteria. The final section describes appropriate remedial alternatives that have been developed for an example municipal landfill site and presents an evaluation of these alternatives. The purpose of this section is to illustrate how technologies might be combined to form alternatives typically developed for landfill sites and how these are evaluated using the nine criteria.

Additionally, scoping activities, and an appropriate site characterization strategy, have been identified for the example site and included as Appendix A to better illustrate some of the concepts presented in this document. Appendix B of this document contains an historical record of the remedial actions selected for CERCLA municipal landfill sites through FY 1989.

Section 2

SCOPING THE RI/FS FOR MUNICIPAL LANDFILL SITES

Developing a work plan is the first step in conducting an RI/FS at a municipal landfill site. The process of developing a comprehensive scope of work to be defined in the work plan is known as scoping, and has several functions. It identifies the preliminary remedial action alternatives, summarizes the RI/FS objectives, and outlines the tasks necessary to meet these objectives. Because the work plan is the foundation of the RI/FS, the remedial project manager (RPM) should devote considerable attention to preparing it and the individual tasks. Without a definition of a proper work plan, it is unlikely that the RI/FS or the project objectives will be met because it is difficult to achieve loosely defined RI/FS or project objectives that extend over a long time. It should also be recognized that adjustments should be made to the work plan as work on the RI/FS progresses and more is learned about the site.

A primary purpose of scoping an RI/FS, therefore, is to divide the broad project goals into manageable tasks that can be performed within a reasonable period of time. Proper planning also provides the RPM with a mechanism for measuring progress and controlling the project.

The broad project goals for an RI/FS at any Superfund site are to provide the information necessary to characterize the site, define site dynamics, define risks, and develop a remedial program to mitigate or eliminate potential adverse human health and environmental impacts. The tasks that should be performed to achieve these goals include the following:

- Evaluate existing site data (Section 2.1)
- Conduct a site visit (Section 2.3)
- Conduct a limited site investigation, as necessary (Section 2.4)
- Define the conceptual site model (Section 2.5)
- Scope the risk assessment (Section 2.6)

- Identify preliminary applicable or relevant and appropriate requirements (ARARs)
- Develop preliminary remedial action objectives and goals (Section 2.7)
- Develop preliminary remedial technologies (Section 2.8)
- Develop objectives of the RI/FS (Section 2.9)
- Develop data quality objectives (DQOs) (Section 2.10)
- Prepare an RI/FS work plan and sampling and analysis plan
- Prepare a health and safety plan
- Prepare a community relations plan
- Conduct Phase I site investigations
- Evaluate Phase I data
- Refine remedial action alternatives
- Conduct Phase II site investigations, if necessary
- Evaluate remedial action alternatives

The scope of work for a municipal landfill site may be different from the scopes for other types of sites, such as surface impoundments, waste piles, and tank farms. Because waste in municipal landfills is a heterogeneous mixture of materials and may contain liquid and solid hazardous wastes, the number of remedial action alternatives is limited. Therefore, site-characterization strategies that can be used at municipal landfill sites are limited. The specific strategies for characterizing different types of landfill sites are presented in Section 3 of this report. This section focuses on the components of scoping an RI/FS for municipal landfill sites.

2.1 Evaluation of Existing Data

Existing data should be reviewed and evaluated before any other activities are performed, so that the site dynamics can be understood and the scope of the RI can be adequately prepared. Thorough data evaluation is important because it affects both the timing and cost of the RI/FS. The evaluation also identifies the needs and objectives of any limited field investigation, the selection of preliminary remedial action alternatives, the RI/FS objectives, and the development of the DQOs.

To begin understanding site dynamics and scoping the RI, sources of existing data should be identified and the data should be compiled. Information on the area's hydrology and geology should be collected so that contaminant pathways can be identified. Types and sources of hazardous materials in the landfill should be determined, where possible. In addition, regulatory activities should be reviewed, including information on any existing landfill cover. Finally, the results of past sampling and analysis efforts should be evaluated for their usefulness.

If, after existing data are evaluated, it is determined that there is insufficient information to define site dynamics and to develop the conceptual site model, limited field investigations should be conducted. Limited field investigations are performed during scoping, and should be limited to easily obtainable data for which results can be received in a short period of time. The existing data, together with the results of any limited field investigations, should then be used to construct the conceptual site model and to develop the preliminary remedial action alternatives and the RI/FS objectives.

2.1.1 Sources of Information

Federal, state, and local agencies may have pertinent information for evaluating a site. Although some of this information may be general, it still can be used to establish a baseline. As an example, records of previous ownership may indicate that there were manufacturing operations at a site. Exact locations of buildings may not be available, but the materials used in manufacturing operations could suggest that additional analytical parameters be tested. In addition to government sources, other

data sources that may be particularly useful in obtaining more specific information on a site include:

- Preliminary assessment/site inspection data
- HRS scoring package
- Potentially responsible party (PRP) search report
- Aerial photographs
- State files, including inspection reports, permit applications, and well data bases
- Interviews with state inspectors, local government bodies, and local residents
- Site history, ownership, operation/disposal practices (past and present, from past owners, operators, or generators)
- Weight tickets/logs
- Data from original siting studies or engineering designs
- Closure plans

Information available from other agencies and the types of information generally available from other potential data sources are summarized in Table 2-1 of *Guidance for Conducting Remedial Investigations and Feasibility Studies Under CERCLA* (U.S. EPA, 1988d). Appendix B of this document provides information on technologies most frequently implemented at municipal landfill sites based on a review of RODs signed through 1989.

Existing data should be evaluated and summarized in formats that are easily reviewed by individuals not involved in the collection process. Reviewing and evaluating the available data will lead to an understanding of the site conditions and identification of evident data gaps. During this activity, the quality (that is, accuracy and precision) of the data and their conformance with the quality control (QC)

protocols under which they were collected should be assessed. If possible, preliminary data (e.g., condition of cap) should be confirmed by onsite observations.

2.1.2 Types of Data and Data Quality

At this early stage, it is important to focus on compiling as much information as possible about the site's characteristics and hydrogeological setting. Although the complete set of desired information is not always available or of good quality, it is important to gather all that is available. This information includes:

- The landfill's condition, especially its slope stability, the presence of underground fires, levels of methane gas, and amount of cover
- Areas of suspected contamination, unusual surface patterns, or unusual surface features (for example, mines)
- Boundaries of areas of suspected contamination
- Depth to groundwater and seasonal fluctuations
- Existing site conditions, such as recent construction of neighboring houses
- Site and property boundaries and landfill depth
- Existing residential, municipal, and industrial wells, including construction and analytical data
- Details of landfill construction, such as drainage channels, clay liners, cap construction (full or partial), facility base grades, present engineering controls (if any), and any current landfill gas venting
- Evidence of leachate seeps, contaminated surface water runoff, or other spread of contamination
- Nature of the soils around and under the landfill (for example, permeability, composition, clay, organic content)

- Nature and characteristics of material in the landfill, particularly chemical composition of hazardous waste
- Nature of disposal practices (If wastes were segregated, locate potential hot spot areas).

As part of this compilation, data quality should be evaluated to determine the uncertainty associated with the conclusions drawn from existing data and their usability. Uncertainty about the adequacy of existing data can arise from two sources: the representativeness or the specificity of the sampling techniques used to collect the data, and the validity of the analytical methods used. The representativeness of data can be assessed by reviewing their sources. The rationale and method of sample collection should be determined. The analytical methods should be reviewed to determine if the analyses are appropriate to the RI/FS objectives. Data validation identifies invalid data and qualifies the usability of the remaining data. Formal data validation procedures are used to identify data that are the result of improper analytical procedures. QC information, if available, can be reviewed to assess the validity of the analyses. The usability of data without QC information can sometimes be assessed by using statistical techniques or by using professional judgment. Statistical techniques can be used to judge whether the data are consistent by examining their distribution. Data values that are exceptional may be suspect and should be verified with additional samples of known quality. Additional information on the statistical evaluation of data can be found in *Statistical Methods for Evaluating the Attainment of Superfund Cleanup Standards, Volume I: Soils and Solid Media* (U.S. EPA, 1989a).

Other information that is not classed as valid because of QC restrictions can be used in establishing a hypothesis about contaminant behavior over time. These data generally should not be used in making final decisions about the need for cleanup, but they can help in developing an understanding of site dynamics, sampling strategies for the RI, and preliminary remedial action alternatives. Factors that must be considered in evaluating the data for their usefulness are:

- The age and comparability of the data sets. Standard methods of sample collection and analysis may change over time; thus, sample results may not be directly comparable.
- The existence of replicate sample data for estimating precision.
- The sampling design used to collect the samples (for example, were both upgradient and downgradient wells located at the landfill for the collection of the groundwater samples?).
- The methods used to collect, preserve, handle, and transport the samples.
- The analytical methods used to estimate pollutant concentrations (for example, does the analytical method provide results that can be used for risk assessment, or is its usefulness limited to site characterization?).
- The length of time samples were held before analysis (for example, volatile organic analysis has a 14-day allowable holding time or a 7-day holding time when not preserved with acid).
- The published sensitivity or detection limit of the analytical methods (for example, is the detection limit higher or lower than the chemical-specific ARAR?). The detection limit should be lower than both the chemical-specific ARARs and appropriate risk-based concentrations.
- The quality control measures used by field and laboratory teams (for example, were blank samples used to determine if samples were contaminated during collection or analysis?).

The assessment of data reliability should also extend to the entire site investigation process. The rationale for selecting the sampling locations and for determining the completeness of the sampling should be evaluated. The sampling plans and methods, if available, should be reviewed for aspects of the site useful for determining the RI/FS objectives.

An important part of reviewing and evaluating the available data is assessing their reliability, that is, the extent to which the data represent site conditions. The dates of maps, drawings, and plans should be checked. Sampling locations should be evaluated for representativeness. Analytical data should be checked against internal laboratory and source QC criteria (blanks, duplicates, spike/recovery), and the methods of sample collection, preservation, handling, and sampler decontamination should be examined for potential irregularities. If more than one laboratory tested samples from the same area on the site, the results should be assessed for consistency, and variations in methodology should be identified.

The level of effort to review the data quality may be significant if large amounts of potentially high quality data are available. More typical, however, is the case where some analytical data are low or unknown quality and will be used only in the development of the initial site conceptual model and initial sampling planning activities. In this case, data quality review may not require a significant level of effort.

2.1.3 Presentation of Available Data

Whenever possible, the available data should be summarized in graphs, tables, or matrices. Data can also be presented as isoconcentration maps for parameters that depict the degree and extent of contamination for the various media or hydrogeologic units. These compact formats allow for efficient presentation, comparison, and use of large amounts of data. A written summary is also valuable for conveying data trends and general conditions. All summaries, whether graphic, tabular, or written, should identify both what is known (conditions at the site) and what is not known (evident data gaps).

2.2 Existing Data Evaluation Results and Report

The evaluation of existing data should result in the preparation of a preliminary base map, geologic cross sections, a hydrology summary, preliminary waste characterizations, and a summary of sampling activities and results. Figure 2-1 presents a flow diagram for gathering

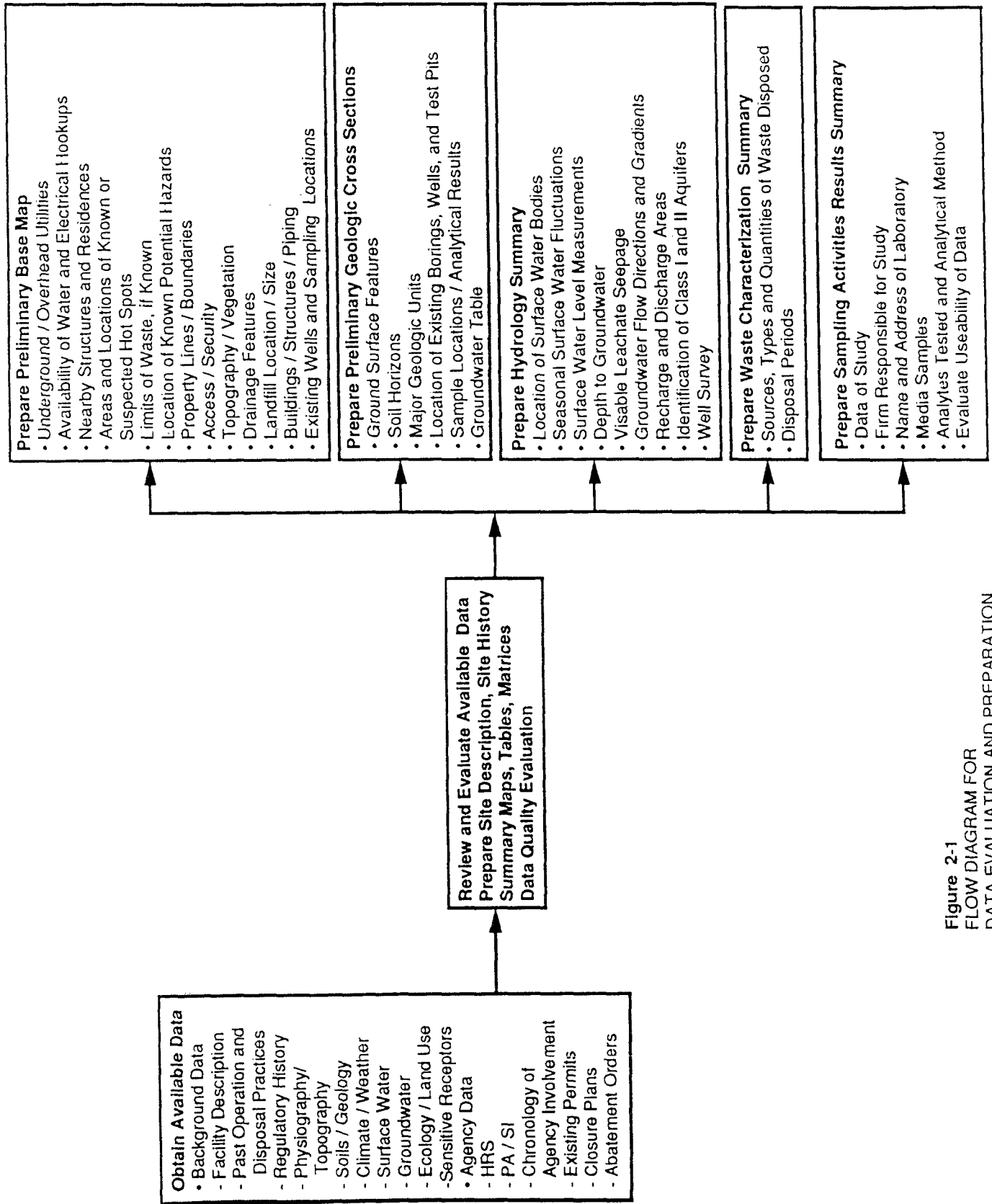

Figure 2-1
FLOW DIAGRAM FOR
DATA EVALUATION AND PREPARATION

evaluating, and preparing data for an RI/FS at a municipal landfill site.

Inadequate data review during this stage of the RI/FS can result in a misdirected focus of the study, which may cause the collection of unnecessary samples, an escalation of field investigation costs, and/or project delays. As an example, inadequate data review during scoping to determine the need for treatability studies for leachate/groundwater or landfill hot spots may result in project delays and increased costs.

2.2.1 Site Description

The site description should provide accurate, detailed, and current information on the site. A physical description of the site and its surroundings and a preliminary base map should be prepared. Data in the hazard ranking system (HRS) scoring package and the preliminary assessment/site inspection (PA/SI) should provide some of the basic information. The base map should include:

- Surface water drainage patterns and site discharge locations
- Locations of existing residential, municipal, and industrial wells, and surface water intakes
- Presence of wetlands/floodplains, wildlife habitats, scenic rivers, and historical archeological resources
- Onsite and offsite buildings, structures, and piping, including existing landfill gas extraction equipment
- Area and site topography and vegetation
- Underground and overhead utilities in the vicinity of the site (All utilities that could possibly impact geophysical surveys should be identified during scoping.)
- Availability of water, sewer, phone, and electrical hookups for the site
- Nearby structures, residences, and other land uses

- Previous sample locations
- Known or suspected hot spots
- Locations of potential hazards (for example, hazards due to falls, heavy-equipment operation areas, electrical power lines)
- Areas of active landfilling operations
- Property lines, facility and refuse boundaries
- Access and security (for example, roads, fences, gates)

The site map should differentiate between the site boundary (the area of the landfill) and the property boundaries (total area of the property may not necessarily be used as a landfill). The preliminary base map can be developed from existing site maps, aerial photographs, or a topographic survey. EPA's Environmental Photographic Interpretation Center (EPIC) in Warrenton, Virginia, can provide a wide range of information on a site, such as:

- Aerial photographs and analysis for a single date
- Aerial photographs and analysis over time either for the site itself or for a wider area (historical analysis)
- Topographic mapping at 1-foot to 5-foot contour intervals
- Orthographic mapping, which is a rectified photoimage with a superimposed topographic map

Existing figures, photographs, and maps may be useful sources of historical information but should not be relied on for information on current site conditions. A fly-over of the site may be necessary to obtain current aerial photos and/or to conduct a topographic survey. If a subcontractor must be procured for this activity, it may have to be delayed until the RI fieldwork is conducted.

As mentioned above, the site description should include the areas, if any, of active landfilling operations; locations selected for sampling or well installation should consider the impact on the site's normal operation and maintenance. Meteorologic data should also be collected and considered during the development of the work plan. Meteorologic data can be used to determine appropriate times for site visits, to direct sampling efforts, and to evaluate remedial action alternatives, such as incineration, capping, or grading. Barometric pressure data are also useful for interpreting landfill gas volume collection data.

2.2.2 Site History

The site history section should detail, in chronological order, the history of previous regulatory actions, disposal activities, types and quantities of wastes, previous owners or operators, site uses, and site engineering studies. Significant effort should be expended in detailing the specifics of disposal activities and of types and quantities of wastes. Site records and interviews with nearby residents and former site operators are valuable sources of this information.

The history of previous disposal activities at a municipal landfill often directly affects the RI objectives, specifically the need to determine whether hot spots may be present and worthy of investigation. In addition to investigating a potential principal threat, the contents of hot spots are important for associating PRPs with the site. Identifying the chemical components may aid in identifying the sources of the waste in the hot spots.

A brief history of operations at adjoining or nearby facilities and other relevant environmental contamination at or near the site should also be included. These potential offsite sources of contamination should be considered during the development of the work plan. They may affect the choice of sampling and monitoring well locations and may contribute contamination to various media. Multiple sources of contaminants in the vicinity can make it difficult to identify all PRPs.

2.2.3 Regional and Site Geology and Hydrogeology

In addition to the preliminary site base map, preliminary geologic cross sections should be developed, if possible, to provide a three dimensional overview of soils and geology and the possible extent of soil and groundwater contamination at the site. The purpose of this effort is to identify any changes or correlations in the type and movement of contamination and soil types and structure. This information will be used to:

- Estimate the depth of the landfill
- Estimate the depth to groundwater
- Identify the limits of subsurface sampling programs
- Select appropriate soil sampling and drilling methods

The preliminary soil/geologic cross-section can be developed from existing site maps, soil and geologic publications, reports on soil borings and monitoring well installation, and analytical results of soil sampling and groundwater sampling, if available. A suggested type of cross-section is shown in Figure 2-2. Features shown on a cross section of this type should include:

- Ground surface features (for example, buildings, above-ground tanks, roads)
- Soil horizons (for example, clay lenses or other soil layers with differing characteristics)
- Major geologic units
- Locations of domestic and/or public supply wells
- Locations of existing borings, wells, and test pits
- Existing sample locations, including the location of offsite sampling locations to

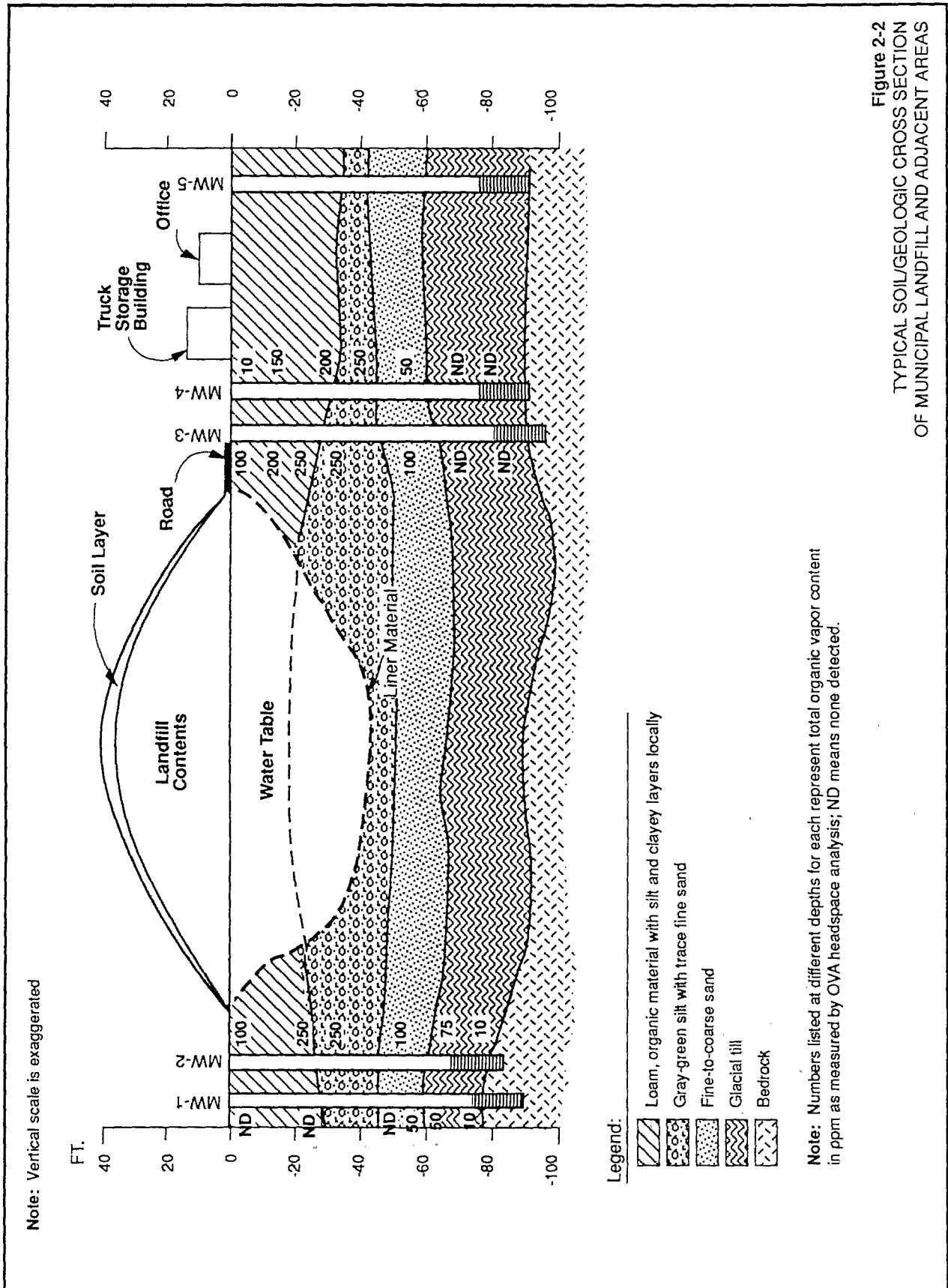

Figure 2-2
TYPICAL SOIL/GEOLOGIC CROSS SECTION
OF MUNICIPAL LANDFILL AND ADJACENT AREAS

determine whether offsite contamination is a problem in the area

- Depth to groundwater

If no soil borings, test pits, or monitoring wells have been installed at the site, it may not be possible to construct a detailed preliminary cross section. However, geologic and soil publications--such as United States Geological Survey (USGS) reports, Soil Conservation Service data, state geological survey reports, state well databases, logs of public supply companies, and information from local well drillers--should be available to give an estimate of the thickness of unconsolidated material, the depth to the groundwater table, and current aquifer uses (e.g., agricultural, drinking water).

If sufficient information from these sources is available, this section should also identify the origin, texture, and distribution of unconsolidated materials; the origin, texture, nature, and distribution of bedrock units; and the texture and classification of surficial soils. In addition, if available, this section should identify rock type, porosity (primary and secondary), areal extent of geologic units, and structural geology. This information can help identify complex hydrogeological units and define recharge and discharge zones and flow systems. The regional and site-specific geology are described in this section to help identify contaminant pathways and develop a conceptual site model.

2.2.4 Hydrology

Collection and evaluation of hydrologic data should include both surface water and groundwater components.

2.2.4.1 Surface Water

Surface water bodies near the site should be identified to (1) evaluate the potential impact of the landfill on the body of water, (2) understand the relationship, if any, between the surface water and groundwater flow at the site, and (3) determine their potential to be discharge locations for treated leachate and surface runoff from the capped landfill.

Groundwater flow may be affected by seasonal surface water fluctuations and may either discharge

to surface water or be recharged by surface water at different times of the year. This information may be identified by comparing concurrent groundwater and surface water level measurements taken seasonally. Preliminary information for groundwater can be obtained from USGS hydrogeologic atlases, state aquifer maps or water resource overlays, the local board of health, water control board, planning commission, or the local Department of Public Works.

2.2.4.2 Groundwater

A groundwater assessment should be performed at and near the site to determine depth to groundwater, local and regional groundwater flow directions, gradients, recharge areas, discharge areas, and to identify aquifers used by private and public water supply wells in the area. This information may be determined by evaluating the data gathered for the section on regional and site-specific geology (Section 2.2.3). If no monitoring wells have been installed at the site, it may not be possible to assess specific groundwater levels or local flow directions at the site. However, geologic publications, as mentioned in Section 2.2.3, should be able to give an estimate for the region of the depth to the groundwater table.

If possible, a well survey should also be initiated during scoping. This survey can serve a number of purposes, including evaluating the "usability" of existing wells for future field activities and accounting for pumping influences when selecting additional sampling locations for monitoring wells. This survey would also be useful for identifying potentially contaminated wells being used as domestic, municipal, or industrial supplies. Well installation logs, if available, may be useful in preparing geologic cross sections.

2.2.5 Waste Characterization

The types and quantities of wastes within the landfill are estimated during waste characterization. This information can be developed from landfill disposal records; county, state, and EPA records; interviews with current/previous employees of the landfill; aerial photographs; results of sampling landfill contents; and interviews with state inspectors. If available, the

periods of disposal should also be estimated to help identify the likelihood that contaminants will be in the landfill (for example, volatile organics sometimes migrate quickly and may not be present) and to establish PRP responsibility. Although interviews and records searches are time-consuming, the information gathered is very useful in directing the RI/FS process and the selection of remedial action alternatives.

2.2.6 Sampling Activities and Results

A summary of the chemical analytical data collected at or near the site may provide extensive information about the potential effects of the site on the surrounding media and about future data needs. This section addresses the affected media at the site, not the sources, which are addressed under “Waste Characterization” (Section 2.2.5). The summary of sampling activities and results should include the date of the study, the name of the firm responsible for the study, the name and address of the laboratory that performed the analysis, the media sampled, the analytes, and the analytical methods used.

The usability of the data should be evaluated as discussed in Section 2.1.2, bearing in mind that there are several data uses (for example, site characterization, evaluation of alternatives, PRP determination) that require different qualities of data. The existing chemical analysis information (including QC information) should be included in an appendix of the work plan.

2.3 Site Visit

A site visit by the RPM and other appropriate personnel (e.g., state and Federal agency representatives) is necessary during the scoping process to:

- Verify existing data (for example, condition of cap, amount of soil cover, extent of slope erosion)
- Identify existing site remediation systems (for example, landfill gas or leachate collection systems)

- Identify critical areas (for example, possible equipment-staging areas, access roadways, residential areas)
- Visually characterize wastes (for example, leachate seeps, exposed drums, stained soils)
- Gather additional data to support further site evaluation (for example, wetlands, floodplains, biota)
- Evaluate the practicability of geophysical surveys

Detailed examination of a municipal landfill during a site visit is important for several reasons. Observation of slope instability or explosive levels of gas may indicate the need to mitigate an immediate hazard. Details of cap construction may affect the feasibility of remedial technologies. Remedial technologies that use heavy equipment can also be removed from consideration by soft ground surfaces or other conditions limiting access to the landfill.

Characterization of waste materials by visual observation is also important. Visual identification of hot spots or the physical characteristics of the wastes (sludge-like or solid) is necessary for sampling preparation and for ensuring the representativeness of sampling. The physical and chemical characteristics of the waste are key variables in defining alternative technologies for remedial actions and in identifying the most cost-effective actions. Special wastes (radioactive, laboratory packs, etc.) not normally associated with municipallandfills may also be at the site and should be noted during the site visit. However, the certainty of information gathered by visual observation during the site visit is limited. Ideally, a site should be visited when vegetation is minimal. Potential sampling locations should be identified carefully, because later plant growth may cover them. It is sometimes useful to visit a site after a heavy rainfall, if possible, to observe runoff and leachate seepages that may not be visible at other times. A follow-up visit during a dry period may be useful in evaluating the potential for dust generation.

The time needed to complete a site visit will depend on the size and complexity of the site and whether interviews will be conducted. On average, a site visit may take between 1 to 2 days (not including interviews).

The following activities may be performed during the site visit:

- Identification of unusual features, including
 - S Spill areas and stained soils
 - S Evidence of environmental stress to flora or fauna and adjacent wetlands
 - S Presence of waste requiring special handling or precautions
 - S Presence of surface impoundments and aboveground tanks
 - S Presence of underground storage tanks, aboveground vents, or fill pipes
- Examination of landfills, including
 - S Evidence of slope instability, leachate seeps, soil erosion
 - S Details of cap construction, stability, areas of cover cracking, erosion, or subsidence
 - S Evidence of gas release through cap
 - S Approximate perimeter of the landfill
 - S Evidence of partially buried drums or other hazardous materials
 - S Localized areas of stressed vegetation or detection on explosimeter
 - S Factors affecting the accessibility of the landfill to heavy equipment, such as moisture content of the soil, width of benches/access roads

- S Identification of site features that may interfere with the performance of geophysical surveys
- Field characterization of wastes, including
 - S General nature of the wastes--residential, industrial, sludges, or a mixture
 - S Physical state of the wastes--dry, wet, very compressible, firm, free liquids
 - S Physical properties of exposed wastes--odor, gas generation, state of decomposition
 - S Preliminary measurements in hot areas with an organic vapor analyzer (OVA)
- Identification of:
 - S Site utilities, facilities, and structures
 - S Unusual wastes (laboratory packs, cylinders)
 - S Drainage patterns
 - S Possible offsite sources of contamination
 - S Recent construction, including housing developments
- Division of site into grids to facilitate identification of target areas and future remedial activities (a cartesian grid is effective)
- Identification of access, egress, staging, and security points
- Interviews with local residents (opportunity to confirm well survey and also necessary for preparation of community relations plan [CRP])

- Identification and confirmation of features on the preliminary base map and soil/geologic cross-section
- Preparation of photographs of site features
- Performance of air quality monitoring for high levels of volatiles or methane

A health and safety plan (HSP) should be prepared for the initial site visit unless an HSP was developed for previous site work, in which case this plan may be adequate. If no plan exists, a limited HSP should be developed on the basis of existing data. The RPM should coordinate with the Regional Health and Safety Officer on the need for the HSP and contents. Requirements for an HSP can be found in *Occupational Safety and Health Guidance Manual for Superfund Activities* (National Institute of Occupational Safety and Health, 1984), *Guidance on Remedial Investigations Under CERCLA* (U.S. EPA, 1985e), and *Standard Operating Safety Guides* (U.S. EPA, 1984c).

2.4 Limited Field Investigation

After existing data have been evaluated and a site visit has been conducted, a preliminary conceptual site model depicting the site's dynamics should be developed. If the information required to develop this model is incomplete, a limited field investigation (LFI) should be conducted. (See Section 2.5 for information on the conceptual site model.) The LFI should be restricted to the collection of easily obtainable data, which can be gathered quickly. Its purpose is to define the scope of work as precisely as possible, given the available information. The LFI typically involves field measurements but may include chemical analysis of groundwater from existing wells or samples from other easily accessible sample locations. The limited field investigation is normally performed during the preparation of the work plan and before extensive sampling begins for the RI.

Table 2-1 is a list of the possible activities that could be performed during an LFI at a municipal landfill site. This table should not be interpreted to mean that all of these objectives (and actions to meet the

objectives) should be met to adequately scope an RI/FS for a municipal landfill site. Rather, the data requirements for adequately scoping the project should be determined on a site-by-site basis. Data needs will differ for each site and will depend on factors such as the results of the existing-data evaluation, the number and type of potential contaminant pathways and receptors, and the RI objectives.

RI reports for municipal landfills were reviewed to determine the usual activities performed during limited field investigations at landfills. These activities are shown in Table 2-1 and can include:

- Property surveys
- Topographic surveys
- Surveys of location, elevation, accessibility of monitoring wells
- Well surveys for all residential wells within the current or potentially affected area
- Collection and analysis of samples from existing monitoring and residential wells
- Surface and volatile emissions survey
- Water level measurements taken from existing monitoring wells
- Survey of gas levels in nearby residences to determine if they are near the explosive range (also in onsite buildings and confined spaces)

Most of this information requires field measurements, which would not be gathered during the site visit. General investigation Table 2-1 continued activities that could be done during the site visit are described in Section 2.3 and not repeated here.

Well installation and other activities requiring subcontracting should be avoided during the LFI. Sampling is also typically not performed; however, sampling of existing and residential

**Table 2-1
LIMITED FIELD INVESTIGATION OPTIONS FOR
MUNICIPAL LANDFILL SITES**

Activity	Objectives	Action
General Investigation	Identify previous site owner/operators and delineate site boundaries. Estimate uncertainties in boundaries.	Conduct property survey or perform a title search or identify property ownership from tax records, or plat maps.
	Locate existing monitoring wells.	Perform location and elevation survey of existing monitoring wells.
	Evaluate site drainage patterns.	Review topographic maps and perform hydrologic survey.
	Evaluate site-cover conditions and surface water drainage.	Perform visual surface inspection with topographic maps. Conduct surface emissions survey.
	Evaluate gas migration, potential, if applicable.	Measure explosive gas levels in nearby residences, or onsite buildings, if present. Also measure in water meter boxes and utility corridors, if landfill gas poses a threat.
	Locate sampling locations.	Survey a grid for the site and cross-reference to sample locations.
	Determine landfill subsidence, if survey is otherwise required.	Measure elevations along crown of fill or install benchmarks in areas of potential subsidence (requires repeat visits by surveyor).
Geotechnical Investigation	Describe geologic features, classify soil.	Conduct visual observation of mechanical erosion, slope instability, differential settlement, and ponding caused by subsidences and cracking.

**Table 2-1
LIMITED FIELD INVESTIGATION OPTIONS FOR
MUNICIPAL LANDFILL SITES**

Activity	Objectives	Action
Hydrogeologic Investigation	Evaluate usefulness of existing monitoring well network.	Conduct a well survey for all wells (residential, commercial, industrial). Determine local uses of groundwater and accessibility of existing wells. Obtain permission for use. Determine if existing wells are obstructed (e.g., by sounding to the bottom of the well).
	Review preliminary locations for new monitoring wells.	Perform fracture-trace analysis in areas with fractured bedrock (can be done through EPIC study).
	Determine location of residential wells and their construction.	Perform well survey for all residential wells adjacent to, and downgradient from, the landfill. Obtain well logs from federal, state, local utilities, or municipal agencies.
	Determine direction of groundwater flow and estimate gradients.	Record water level measurements from existing wells (at least quarterly, to determine seasonal variations).
	Determine rate of groundwater flow in strata and bedrock fractures .	Perform hydraulic conductivity tests on existing wells.
	Confirm previous sampling results for both existing monitoring and residential wells and collect additional data as necessary. Identify areas of groundwater contamination and types of contaminants.	Collect and analyze* samples from monitoring and residential wells. Record quality parameters for the samples analyzed. Compare new results with values from previous studies.
	Determine if residential wells adjacent to, and downgradient from, the landfill are contaminated.	Collect and analyze* tap water samples before any filtration unit and conduct preliminary risk assessment.

*Sample collection and analysis is not usually performed as a part of an LFI but is an option that could provide valuable information for scoping future fieldwork.

wells has been included in this table because this information, if obtainable, will greatly assist in scoping the RI/FS.

The tasks required to perform a limited field investigation may be included in the statement of work for an EPA contractor if the site is designated as a fund-lead site, or they may be attached to the consent order for a PRP-lead RI/FS. Performing an LFI during the development of the work plan often saves both time and money. This is because it takes less time and is less costly to scope the RI/FS correctly the first time than to rescope certain aspects of the project at a later date.

2.5 Conceptual Site Model

The conceptual site model is developed so that an understanding of the site dynamics can be obtained. Its purpose is to describe the site and its environs and to present hypotheses regarding the suspected sources and types of contaminants present, contaminant release and transport mechanisms, rate of contaminant release and transport (where possible), affected media, known and potential routes of migration, and known and potential human and environmental receptors. In general, quantitative data should be incorporated wherever possible. Hypotheses presented by the model are tested, refined, and modified throughout the RI.

Generally, a conceptual site model is based on the existing data evaluation and is developed before any field activities, including those performed as part of an LFI. If insufficient information is available to develop a conceptual site model, the LFI provides the information needed to develop a sufficient model for scoping further investigations.

The conceptual site model is a tool that can assist the site manager in determining the scope of the project, identifying data needs, and establishing preliminary remedial action objectives. For example, if residential areas are upwind of the site and existing data indicate no volatile emissions of concern, then air may be considered an unaffected medium in the model and no further data should be collected during the RI. On the other hand, if residential wells near the landfill are contaminated

and existing groundwater data are limited, then the site model will indicate that groundwater is an affected medium and the collection and analysis of samples from this medium should be included in the RI.

A generic conceptual site model for municipal landfills was developed so that a basis for project scoping could be established. The conceptual site model was developed for municipal landfill sites with data collected from review of 71 municipal landfill RODs. Figure 2-3 presents a schematic diagram of this model, and Figure 2-4 depicts the information as a flow diagram. This generic model may be utilized to develop a site-specific model. After evaluating the data and completing a site visit, the RPM should determine which contaminant release and transport mechanisms are appropriate for the municipal landfill site in question. For example, if hospital wastes or radionuclides are in the landfill, then they should be added as a contaminant source, and the release mechanism, affected media, exposure pathways, and receptors should be identified. Likewise, contaminant release and transport mechanisms and media that are not affected by the landfill should be deleted from Figure 2-4. For example, if the landfill is in a depressed area and surface runoff flows into the landfill area and not away from it, then the two associated release mechanisms, runoff and erosion, can be eliminated from the model. However, if there is uncertainty about the existence of specific contaminant release and transport mechanisms, it should be retained.

The key element in the development of the conceptual site model is to identify those aspects of the model that require more information to make a decision about remediation. For example, if it is not possible to decide whether removal or containment of a known hot spot is the most cost-effective alternative because of uncertainty about volume, early field efforts should include measures to estimate the volume of the material within the hot spot. Or, suppose that existing data show that only volatile organics are of concern in the residential wells. For streamlining the analytical program, chemical analysis of groundwater samples should then be focused on the target compound list

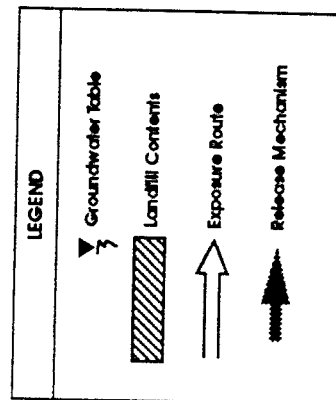
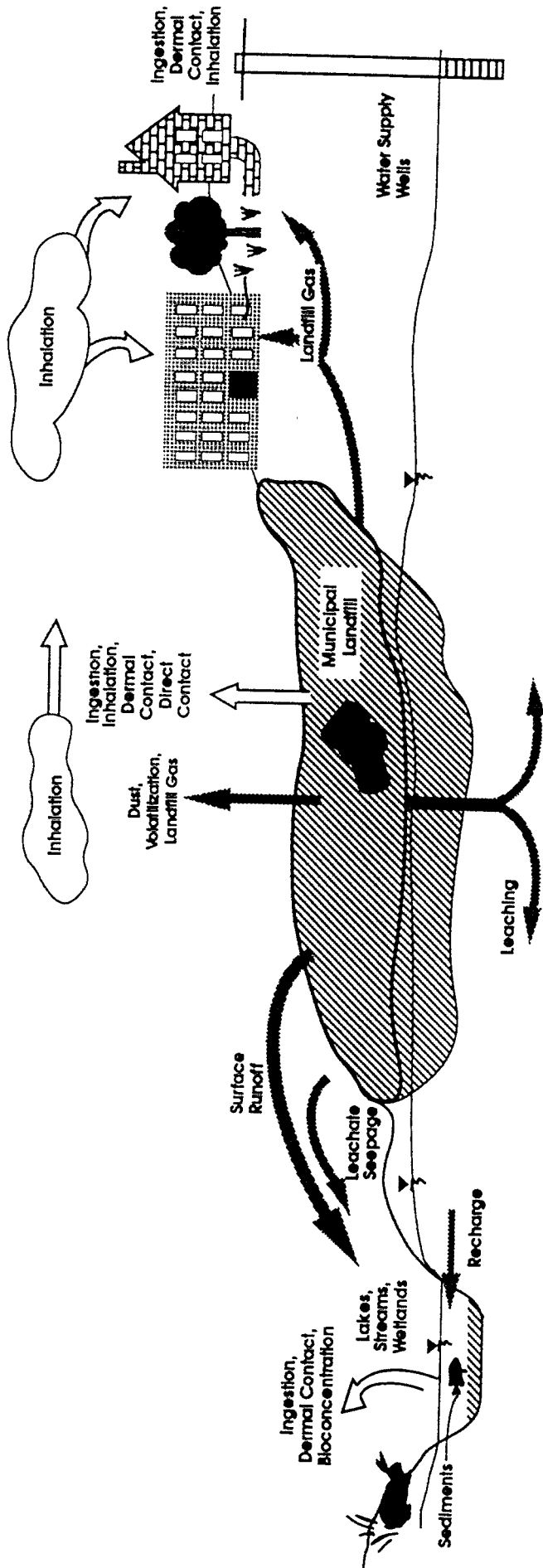

Figure 2-3
SCHEMATIC OF CONCEPTUAL LANDFILL SITE

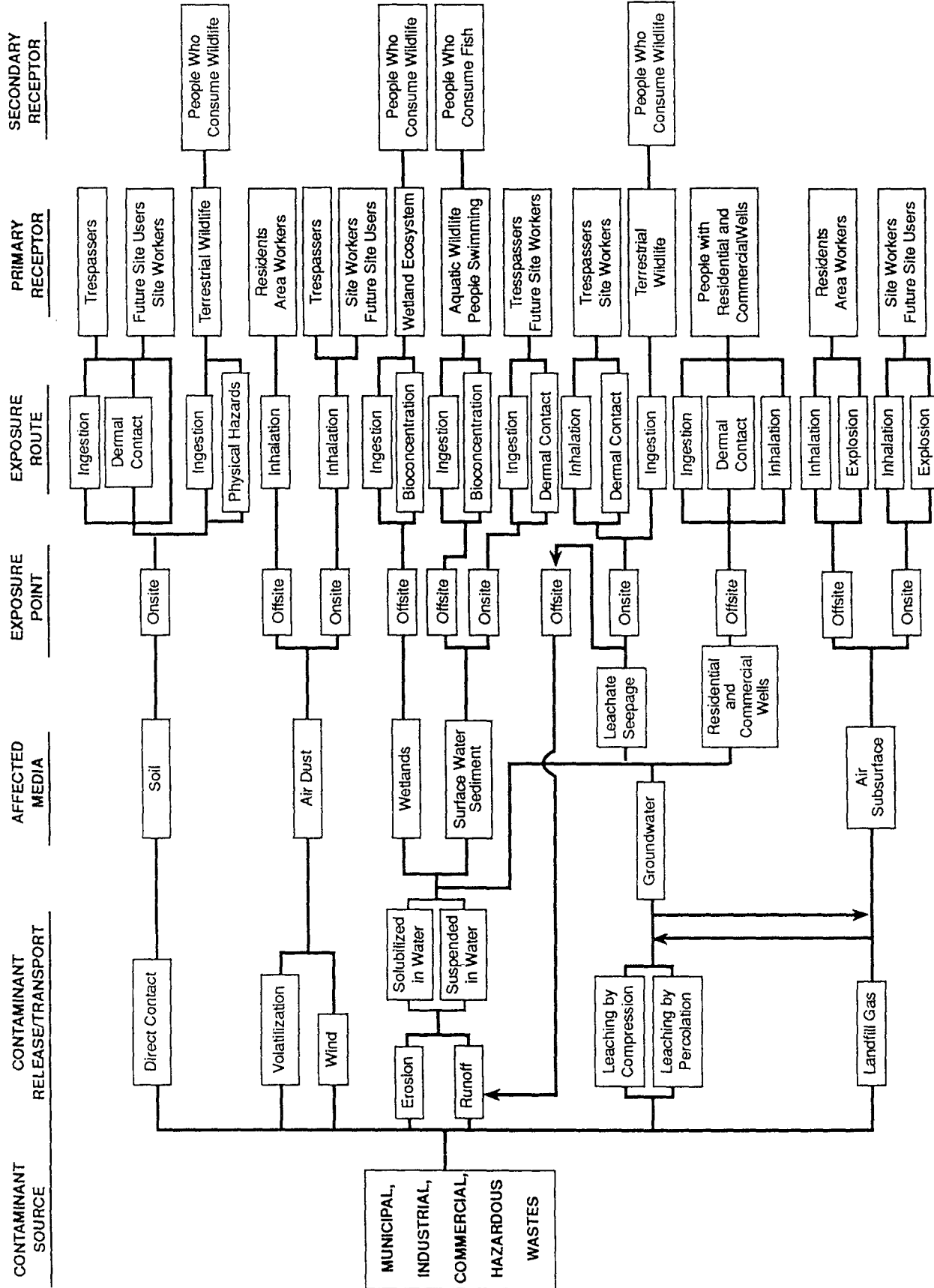

Figure 2-4
POTENTIAL CONCEPTUAL SITE MODEL FOR MUNICIPAL LANDFILLS

parameters (U.S. EPA, 1988a), with some analysis of the target analytes list parameters (U.S. EPA, 1987g) to confirm their absence.

The site model will also indicate the potential human and environmental receptors affected by the site. If quantitative information is developed as part of the conceptual model, it may be possible to develop a preliminary evaluation of potential risks to receptors. Experience and judgment can be used to focus on the contamination that causes the greatest risk or, if standards are available [such as maximum contaminant levels (MCLs)], they can be used to identify potentially affected receptors and the need to initiate remedial action (see Section 2.6).

The site model can also help identify preliminary remedial action alternatives. For example, if contaminated groundwater from the landfill is being used for residential water supply, then preliminary remedial action alternatives could include any of the following, depending on the site conditions: alternative water supply, on-line water treatment systems for each household, capping to prevent downward percolation of precipitation and associated transport of the contaminants from the landfill to the groundwater, and a slurry wall to prevent additional horizontal movement of the contaminated groundwater.

2.6 Risk Assessment

The risk assessment is initiated to help to determine whether the contaminants of concern at the site pose a current or potential risk to human health or the environment and to help determine whether remedial action is warranted. The assessments are site-specific and may vary in the extent to which qualitative and quantitative analyses are utilized, depending on the complexity and particulars of the site, as well as the availability of pertinent ARARs, and other criteria and guidance.

The *Risk Assessment Guidance for Superfund: Human Health Evaluation Manual* (U.S. EPA, 1989k) describes a *preliminary identification of potential human exposure* that is included in the development of the work plan and the Sampling and Analysis Plan. This assessment is based on existing data and information and on the conceptual site

model and is designed to identify data gaps, provide a focus for the RI/FS, and provide support for remediation to proceed, if appropriate.

The *baseline risk assessment* is a quantitative, chemical-oriented evaluation of the potential threats to human health and the environment that would be posed by a site in the absence of any remedial action, i.e., the no-action alternative. The baseline risk assessment is usually quantitative, although qualitative analysis may be appropriate and sufficient. A baseline risk assessment identifies and characterizes the toxicity of contaminants of concern, potential exposure pathways, potential human and environmental receptors, and the extent of expected impact or threat under the conditions defined for the site. The baseline risk assessment can be used as a tool to streamline remedial action decisions by identifying areas where remediation should proceed immediately (see Section 3.7). The *risk assessment for comparison of remedial alternatives* is designed to identify potential threats to human health or the environment that may arise from the execution of various types of remediation activities. Section 6.3 presents a comparative analysis of alternatives for an example municipal landfill site.

The preliminary identification of exposures is conducted during the scoping of the RI/FS and is based on information from the PA/SI and possibly other previous investigations. This exercise uses this existing information to identify the potential area of contamination, chemicals of concern, routes of contaminant transport, and potential exposure pathways to identify data needs and to focus the RI/FS. Because options for remedial action at municipal landfill sites are limited, it may be possible to use this preliminary information, with the addition of toxicity information or ARARs to initiate remedial action, if appropriate. Specifically, early action may be warranted when human health or environmental standards for one or more contaminants in a given media are clearly exceeded. However, because there is often not a lot of data available at this stage, or because data is of questionable quality, it may not be possible to justify an early or interim remedial action at this stage. However, if the

need for an interim or early action is suspected (e.g., temporary landfill cover, groundwater remediation, respectively) but insufficient data are available, these data needs should be identified and the corresponding data should be collected early in the RI process. This may allow for decisions on potential early or interim remedial actions to be made during the baseline risk assessment (Section 3.7). Detailed information can be found on scoping risk assessments in the documents *Risk Assessment Guidance for Superfund--Human Health Evaluation Manual* (U.S. EPA, 1989j), and *Risk Assessment Guidance for Superfund--Environmental Evaluation Manual* (U.S. EPA, 1989c).

2.7 Preliminary Remedial Action Objectives and Goals

Preliminary remedial action objectives and goals are developed during the scoping of the RI/FS to assist in identifying preliminary remedial action alternatives and RI data requirements. Remedial action objectives are general descriptions of what the remedial action is expected to accomplish. The preliminary remedial action objectives are based on the existing data for the site and the conceptual site model. Remedial action objectives are aimed at protecting human health and the environment and should specify:

- The contaminant(s) of concern
- The exposure rate(s) and receptor(s)
- An acceptable contaminant level or range of contaminant levels for each exposure route

Examples of general remedial action objectives for media of concern at municipal landfill sites are presented in Table 2-2.

Remedial action goals are a subset of the remedial action objective; the remedial action goals consist of chemical concentrations that are protective and serve as specific numeric goals for the remedial action. Preliminary remedial action goals should be developed with the preliminary ARARs and exposure assessment. An example of a preliminary remedial action goal would be to prevent ingestion of groundwater containing TCE above 5

micrograms per liter. In this example, the preliminary remedial action goal is based on the MCL for TCE.

It is necessary that both the preliminary risk assessment and preliminary ARARs be used in developing the preliminary remedial action goals. A description of the preliminary risk assessment is presented in Section 2.6.

As part of identifying remedial action goals, ARARs that typically apply to municipal landfill sites are divided into three types:

- Chemical-specific ARARs (MCLs, MCLGs, etc.)
- Location-specific ARARs (floodplains, wetlands)
- Action-specific ARARs (performance design standards)

Potential federal ARARs that may affect municipal landfill sites are discussed in Section 5 of this report.

To assist in developing preliminary remedial action goals, an ARARs table should be developed and should include identifiable contaminants of concern, affected media, regulatory agencies concerned with the media (federal, state, or local), potential remedial action alternatives (see Section 2.8), and regulatory agencies concerned with that action. A more detailed list of chemical concentrations will be generated during development of the DQOs.

Promulgated state ARARs that are more stringent than federal requirements and have been identified in a timely manner must also be included (although they may later be waived if they have not been consistently applied). In particular, the state ARARs for landfill cap design, extracting and monitoring landfill gas, or discharging contaminated groundwater should be incorporated. It is important that care be used in identifying and eliminating potential ARARs at this stage of the scoping process. In developing remedial action goals, "to-be-considered" (TBC) material such as proposed MCLs should also be evaluated. TBC material

**Table 2-2
PRELIMINARY IDENTIFICATION OF REMEDIAL ACTION OBJECTIVES
FOR MEDIA OF CONCERN AT MUNICIPAL LANDFILL SITES**

Environmental Media	Remedial Action Objective
Soils/Landfill Contents (Primarily from hot spots)	Prevent direct and dermal contact with, and ingestion of contaminated soil/landfill contents
Air/Dust	Prevent inhalation
Landfill gas	Prevent inhalation and explosion
Surface water	Prevent ingestion, adsorption, and bioconcentration
Sediment	Prevent ingestion, adsorption, and bioconcentration
Groundwater	Prevent ingestion and dermal adsorption
	Prevent migration to surface waters
Leachate Seeps	Prevent onsite inhalation and dermal adsorption
	Prevent migration to surface waters

includes nonpromulgated advisories and guidance issued by the federal or state government, and often reflects the latest scientific information on health effects, detection limits, and technical feasibility.

2.8 Preliminary Remedial Technologies

2.8.1 Development of Preliminary Remedial Action Alternatives

Preliminary identification of remedial action alternatives for each medium of interest should begin after the identification of the preliminary remedial action objectives. Developing the preliminary remedial action alternatives at this time and before determining the RI scope has several advantages:

- Defining the degree of detail necessary in delineating the extent of groundwater or soil contamination
- Identifying data needed for evaluating remedial action technologies

- Identifying action-specific ARARs that may influence the scope of RI activities

The number of practicable remedial actions available for municipal landfills is limited. They are based on previous experience, engineering judgment, and the NCP expectations. As stated in the NCP, EPA expects that containment technologies will generally be appropriate for waste that poses a relatively low long-term threat or where treatment is impracticable (40 CFR Sec. 300.430(a)(iii)(A)). In addition, U.S. EPA expects treatment to be considered for identifiable areas of highly toxic and/or mobile material that constitute the principal threat(s) posed by the site (40 CFR Sec. 300.430(A)(iii)(C)). Remedial actions which are most practicable for municipal landfill sites are discussed in more detail in Section 4.

The remedial action alternatives developed at this time will be refined throughout the RI/FS. Although these alternatives will direct the site characterization activities and will form the basis for the FS, they do not necessarily have to limit the alternatives considered later in the FS. However, if alternatives that are not identified here are later considered in the FS, it may be necessary to collect additional site data in a

second phase of the RI. This approach may contradict the goal of streamlining the RI/FS for municipal landfill sites, and it is therefore important that potentially viable alternatives are not eliminated too early in the process. On the other hand, alternatives should be ruled out at this stage if they are clearly unsuited for the site (that is, technically infeasible or inappropriate for the site and waste characteristics) or if the costs are grossly excessive. An example of an impracticable alternative might be excavation and incineration of the contents of a landfill that contains more than 100,000 cubic yards of waste.

As stated previously, remedial action objectives are developed as a first step in identifying remedial action alternatives. General response actions (for example, treatment or containment) are then identified to satisfy the remedial action objectives for each medium of concern. Technology types (for example, chemical treatment) necessary for achieving each remedial action objective are identified, followed by the identification and evaluation of technology process options for each technology. Uncertainties about existing site conditions that preclude choosing a remedial action alternative should be highlighted to focus sample design, collection, and analytical methods.

The site characterization proposed at municipal landfill sites (see Section 3 of this report) reflects the number of remedial alternatives available. Several technologies or alternatives are unlikely to survive screening in the FS for effectiveness, implementability, or cost reasons. These alternatives should be eliminated in the preliminary screening stage or as potential alternatives are being developed. As an example, complete excavation of a large landfill with subsequent treatment or disposal is not generally feasible because the costs would be grossly excessive for the effectiveness they provide. Additionally, excavation of a landfill may cause greater risks than it prevents. Likewise, treatment or offsite disposal is not typically considered for landfill contents because most of the waste within landfills is a heterogeneous mixture of materials.

Remedial action alternatives for landfill sites are practically limited to source control by capping and possibly removal or treatment of hot

spots, groundwater extraction and treatment, and landfill-gas control. Onsite surface water, sediments, and wetlands are typically addressed by either source control or groundwater treatment. These alternatives are often combined with institutional controls, alternative water supply, or fencing for a complete remedial action. As with all Superfund sites, the no-action alternative must also be evaluated for all media. This alternative involves no additional activities by EPA, thereby providing a baseline for evaluating other alternatives.

Figure 2-5 portrays a conceptual model for identifying technologies that will lead to achievement of specific remedial action objectives at municipal landfill sites.

2.8.2 Review of Remedial Technologies in CERCLA Landfill RODs

To identify the most viable remedial technologies for use at municipal landfill sites on the NPL, CERCLA landfill RODs through 1989 were reviewed. Table B-1, in Appendix B of this document, lists RODs that were reviewed. A source control ROD has not yet been completed for some of the sites, and a footnote in Table B-1 indicates those sites where partial remedies have been implemented to date (for example, remedies for groundwater contamination). The information presented in this section is based on the NCP expectations and the remedies outlined in the ROD documents. Since the ROD precedes the remedial design and remedial action (RD/RA) phase, some of the remedies indicated may not have been implemented yet. However, the information is still valuable for remedy selection purposes. Additional information on the status of specific remedial actions can be gathered by contacting the EPA Regional office in which a specific ROD was written.

A comprehensive list of the technologies used at specific sites in each of the EPA Regions is also presented in Appendix B (Table B-2). When conducting a feasibility study for a specific site, an EPA RPM could use this list to identify sites within his or her region for which the same technologies were considered. Additional information could then be gathered on those sites to help in the FS process. Table B-3, also included in Appendix B, presents a

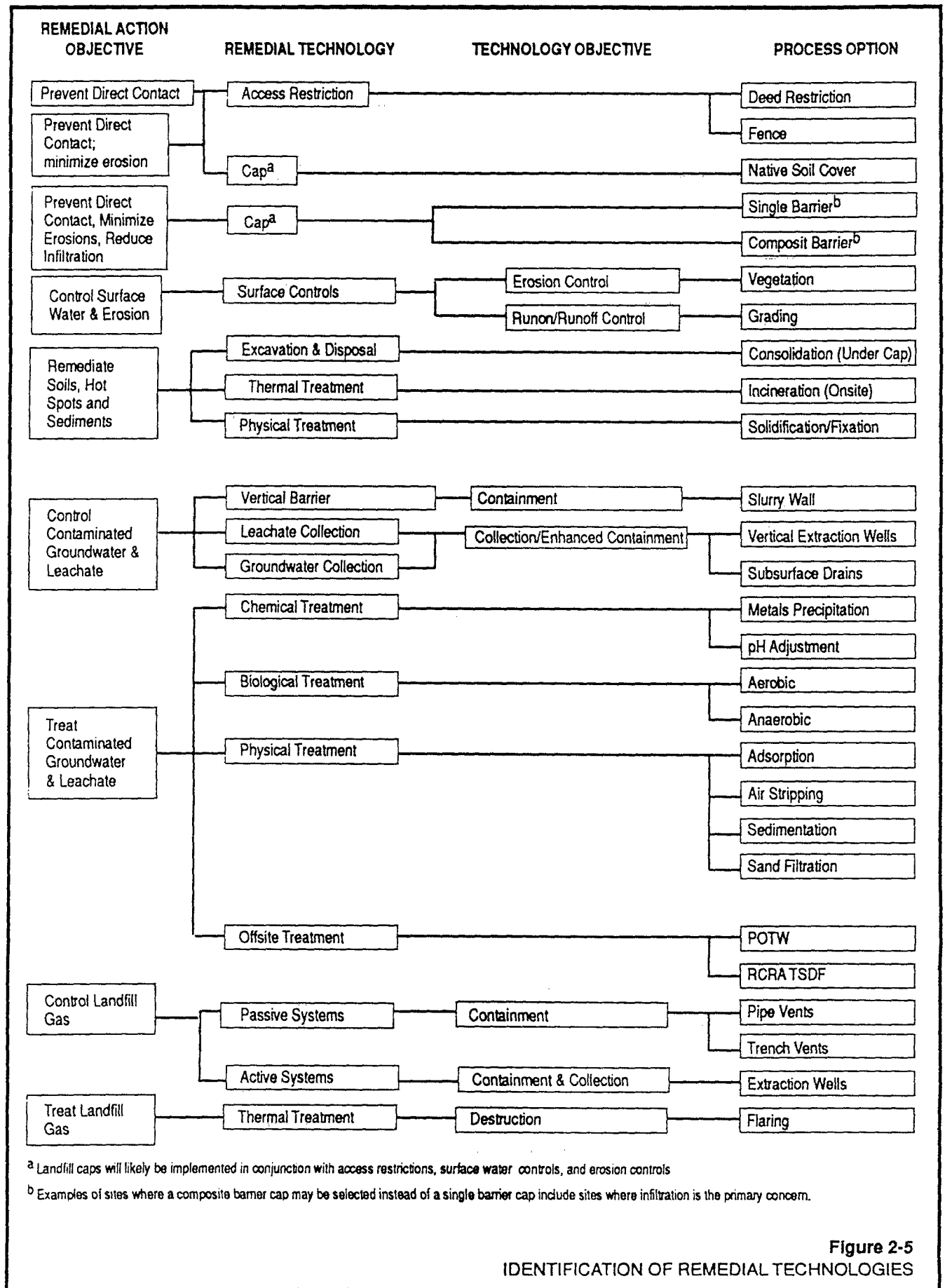

Figure 2-5
IDENTIFICATION OF REMEDIAL TECHNOLOGIES

summary by EPA Region of the frequency with which specific technologies were implemented at the CERCLA municipal landfill sites. This information was used to determine which technologies appear to be most practicable for CERCLA municipal landfill sites based on past experience.

Table 2-3 presents brief descriptions of remedial technologies that could be applied to various environmental media at municipal landfill sites. These technologies were identified on the basis of the ROD review mentioned above. Also included in this table are comments that can assist the RPM during development of remedial action alternatives. The evaluation comments identify situations where a technology may be practicable, and therefore, worthy of consideration. A detailed description of the most practicable technologies, including the data requirements to evaluate these technologies, can be found in Section 4 of this report.

The need for treatability testing to evaluate remedial technologies should be identified during project scoping. During scoping, a literature survey should be conducted to gather information on a technology's applicability, performance, implementability, relative costs, and operation and maintenance requirements. If practical candidate technologies have not been sufficiently demonstrated or cannot be adequately evaluated on the basis of available information (e.g., characterization of a waste alone is insufficient to predict treatment performance or the size and cost of treatment units), then treatability testing should be performed. The treatability testing program should be designed and implemented during the RI, while other field activities are underway. Additional information on treatability studies can be found in the documents titled, *Guide for Conducting Treatability Studies under CERCLA* (U.S. EPA, 1989i) and *Summary of Treatment Technology Effectiveness for Contaminated Soil* (U.S. EPA, 1989k).

2.9 Objectives of the RI/FS

The overall objectives of the RI/FS are to:

- Complete a field program for collecting data of known and acceptable quality to

evaluate the type, extent, and magnitude of contamination in the surface and subsurface soils, landfill gas, groundwater, surface water, and sediment of ponds and wetlands

- Determine the present and future risks to human health and the environment from existing contamination
- Develop and evaluate remedial action alternatives where unacceptable risks are identified

If a risk to human health or to the environment exists and remedial action is necessary, the objective of the RI/FS is to select a cost-effective remedial action that minimizes or eliminates exposure to contaminants from the landfill. Achieving this objective requires a series of decisions involving several interrelated activities. These activities are based on the work plan, which specifies the information necessary for developing a cost-effective data-collection program and for supporting subsequent decisions.

During scoping, decisions are made to identify the remedial action alternatives that could be implemented if certain site conditions were met. Information about a site is gathered to determine whether the site meets the conditions that would allow a particular alternative to be implemented. The objectives of the RI are therefore to characterize the site to assess if risks to human health or to the environment are present and to provide sufficient information to develop and evaluate remedial action alternatives. Physical information about the site is necessary to differentiate among the technologies available for each remedial action alternative. This information is obtained during the RI. In addition to specific field tasks, the RI objectives should address the broad project goals. If this information has not been previously collected during the initial site scoping, it must be collected during the RI. This information includes characterizing the landfill for the environmental setting, the proximity and size of human population, the nature of the problem(s), the treatability testing for contaminated groundwater and leachate (and possibly for hot spots), and the potential remedial actions.

**Table 2-3
REMEDIAL ACTIONS USED AT LANDFILL SITES**

Environmental Media	General Response Actions	Remedial Technologies	Process Options	Description	Evaluation Comments
Soils/Landfill Contents	No Action			No action.	Required by NCP to be carried through detailed analysis of alternatives.
	Access Restriction	Deed Restrictions		All deeds for property within potentially contaminated areas would include restrictions on use of property.	Potentially viable.
		Groundwater Restrictions	Permits	All deeds for property with potentially contaminated areas would include restrictions on development and domestic use of groundwater.	Potentially viable.
		Fencing		Security fences installed around potentially contaminated areas to limit access.	Potentially viable.
	Containment	Surface Controls	Grading	Reshaping of topography to manage infiltration and run-off to control erosion.	Potentially viable.
			Revegetation	Seeding, fertilizing, and watering until a strand of vegetation has established itself.	Potentially viable.
		Cap	Native Soil	Uncontaminated native soil placed over landfill.	Viable in cases where direct contact/erosion are prime threats. Also may be viable in cases where majority of source is below water table and leaching is not a significant release mechanism. Unless engineered to do so, will not result in reduction in infiltration.
			Single barrier	FML liner or compacted clay over site. Usually protected with additional fill above, and topsoil. Clay cap is normally 2 feet thick.	Potentially viable in situations where it is not necessary to comply with RCRA Subtitle C.
	Double barrier	Compacted clay covered with a synthetic membrane (20 millimeter minimum) followed by 1 foot of sand and 1.5 feet of fill and 6 inches of topsoil to provide erosion and moisture control and freeze-thaw protection.	Potentially viable. Provides maximum protection from exposure due to direct contact. Also, this is the most effective capping option for reducing infiltration in compliance with RCRA guidance.		

**Table 2-3
REMEDIAL ACTIONS USED AT LANDFILL SITES**

Environmental Media	General Response Actions	Remedial Technologies	Process Options	Description	Evaluation Comments
Soils/Hot Spots	Removal	Excavation	Mechanical Excavation	Use of mechanical excavation equipment to remove and load landfill wastes for disposal.	Potentially viable for hot spot areas. May release VOCs to the atmosphere posing a threat to nearby residents. Although VOC release are usually controllable, potential for fires and explosions from methane gas present.
			Drum Removal	Excavation of subsurface drums applies to hot spots areas. A drum grapppler, a drum cradle, or a sling attached to a backhoe or crane, or a front-end loader can be used from drum removal.	Potentially viable for hot spot areas. Potential for fires and explosions from flammable material.
			Consolidation	Refers to consolidation under a landfill cap of excavated material from hot spot areas.	Potentially viable for hot spot areas.
		Disposal Onsite	RCRA Type Landfill	Permanent storage facility onsite, double lined with clay and a synthetic membrane liner and containing a leachate collection/ detection system.	RCRA landfills are usually not constructed onsite because of typically poor site characteristics and great expense.
		Disposal Offsite	RCRA Landfill	Transport of excavated soil to a RCRA permitted landfill.	Potentially viable for hot spot areas. RCRA Land Disposal Regulations may require treatment of waste prior to disposal.
	Soil Treatment	Thermal Treatment	Onsite Incineration	Landfill wastes are thermally destroyed in a controlled oxygen sufficient environment.	Potentially viable for hot spot areas. High concentration of inorganics would inhibit efficiency. May require pretreatment for debris.
			Low Temperature Thermal Volatilization	VOCs removed from soil in a drying unit.	Potentially viable for VOC hot spot areas. However, it is rarely effective by itself because of mixed nature of waste material including inorganics and nonvolatile fraction of organics, and may require pretreatment of debris.

**Table 2-3
REMEDIAL ACTIONS USED AT LANDFILL SITES**

Environmental Media	General Response Actions	Remedial Technologies	Process Options	Description	Evaluation Comments
Soil/Hot Spots (Continued)	In Situ Treatment	Biological Treatment	Biodegradation	Soils seeded with microorganisms and nutrients to allow biological degradation.	Potentially viable for hot spot areas. Pilot testing is required to design the biodegradation process. Effectiveness is uncertain since results have not been demonstrated with diverse mixed wastes typically present at municipal landfill sites.
		Physical Treatment	Vapor Extraction	Volatile organics stripped from soil and recovered in vapor form through extraction wells.	Potentially viable--applicable for removal of VOCs; inorganic and semivolatle contamination would remain..
			Solidification/ Stabilization	Soil mixed with an pozzolanic/cement material which can solidify and reduce mobility of contaminants.	Potentially viable for hot spot areas. Effective for soils contaminated with inorganics and low concentrations of organics.
		Offsite Treatment	RCRA Incinerator	Incineration of contaminated soils at a RCRA-permitted facilities.	Rarely viable due to unavailability and expense.
Air/Dust	Containment	Dust Controls	Cover/Cap	Uncontaminated native soil placed over landfill.	Potentially viable for dust control.
Groundwater and Leachate	No Action			No Action.	Required by NCP to be carried through detailed analysis of alternatives.
	Institutional Controls	Alternate Water Supply	Public Water Supply	Residents will be connected to public water supply.	Potentially viable.
	Containment	Vertical Barriers	Slurry Wall	Trench around site or hot spot is excavated while filled with a bentonite slurry. Trench is backfilled with a soil- (or cement) bentonite mixture.	Potentially viable--effectiveness depends on site characteristics. Slurry wall should be keyed into aquitard or bedrock.
		Horizontal Barriers	Bottom Sealing	Controlled injection of slurry in notched injection holes to produce horizontal barrier beneath site.	Potentially viable--however, very rarely used because of ineffectiveness in achieving an adequate seal.
	Collection	Extraction	Extraction Wells	Series of wells to extract contaminated groundwater.	Potentially viable. May include perimeter wells to collect leachate as well as downgradient wells to capture offsite migration of contaminated groundwater.

**Table 2-3
REMEDIAL ACTIONS USED AT LANDFILL SITES**

Environmental Media	General Response Actions	Remedial Technologies	Process Options	Description	Evaluation Comments
Groundwater and Leachate (continued)	Treatment (may also apply to surface water)	Leachate Collection	Leachate Drains/ Collection Trench	System of perforated pipe laid in trenches onsite to collect contaminated groundwater and lower water table.	Potentially viable.
		Biological Treatment	Aerobic	The use of aerobic microbes to biodegrade organic wastes.	Potentially viable for organics. Sludge produced.
	Anaerobic		The use of anaerobic microbes to biodegrade organic wastes.	Potentially viable for organics. Sludge produced.	
	Chemical Treatment	Ion Exchange	Contaminated water passed through a bed or resin material where exchange of ions occurs between the bed and water.	Potentially viable.	
		Oxidation	Oxidizing agents added to waste for oxidation of heavy metals, unsaturated organics, sulfides, phenolics, and aromatic hydrocarbons to less toxic oxidation states.	Potentially viable.	
		Metals Precipitation	Inorganic constituents altered to reduce the solubility of heavy metals through the addition of a substance that reacts with the metals or changes the pH.	Potentially viable.	
		pH Adjustment	Neutralizing agents (such as lime) added to adjust the pH. This may be done to neutralize a waste stream or to reduce the solubility of inorganic constituents as part of the metals precipitation process.	Potentially viable.	
		Physical Treatment	Granular Activated Carbon (GAC) Adsorption	Passage of contaminated water through a bed of adsorbent so contaminants adsorb on the surface.	Potentially viable.
	Air Stripping		Mixing of large volumes of air with water in a packed column or through diffused aeration to promote transfer of VOCs from liquid to air.	Potentially viable.	
	Sedimentation		Suspended particles are settled out as a pretreatment or primary treatment step.	Potentially viable.	

**Table 2-3
REMEDIAL ACTIONS USED AT LANDFILL SITES**

Environmental Media	General Response Actions	Remedial Technologies	Process Options	Description	Evaluation Comments
Groundwater and Leachate (continued)	Treatment (continued)	Physical Treatment (continued)	Sand Filtration	Used to filter out suspended particles. May be preceded by coagulation/flocculation step to increase the effectiveness of sand filtration.	Potentially viable.
	Disposal	Onsite Discharge	Aquifer ReInjection	Extracted, treated groundwater is reinjected into the aquifer to accelerate the cleanup	May not be viable due to state ARARs.
		Offsite Discharge	POTW	Extracted groundwater discharged to local POTW for further treatment.	Potentially viable. Requires extensive negotiations with POTW.
		Groundwater Monitoring		Groundwater monitoring of existing or new wells to detect changes in groundwater movement or contamination.	Potentially viable.
Landfill Gas (LFG)	Collection	Passive Vents	Pipe Vents	Atmospheric vents are used for venting LFG at points where it is collecting and building up pressure. Vents are often used in conjunction with flares.	Potentially viable.
			Trench Vents	Constructed by excavating a deep narrow trench surrounding the waste site or spanning a section of the area perimeter. The trench is backfilled with gravel, forming a path of least resistance through which gases migrate upward to the atmosphere. Trenches are most successfully used where the depth of LFG migration is limited by groundwater or an impervious formation.	Potentially viable.
			Interceptor Trenches	Used when a landfill contains saturated refuse near the surface. Constructed by excavating a deep, narrow trench surrounding the waste site or along a section of the perimeter. Backfilled with gravel to form a path of least resistance.	Potentially viable.

**Table 2-3
REMEDIAL ACTIONS USED AT LANDFILL SITES**

Environmental Media	General Response Actions	Remedial Technologies	Process Options	Description	Evaluation Comments
Landfill Gas (LFG) (Continued)	Collection (Continued)	Active Systems	Extraction Wells	Applied extraction vacuum will serve to withdraw LFG in both the horizontal and vertical directions. Wells are connected by a collection header which leads to a blower/burner facility. Vacuum blowers serve to extract the LFG from the wells and push the collected gas through a free vent or waste gas burner.	Potentially viable.
			Air Injection System	Wells are constructed in the natural soil between the landfill and threatened structures. A blower pumps air into the wells, creating a pressurized zone which both retards LFG flow and dilutes subsurface methane concentrations.	Potentially viable. Application of this technology is site specific. Injection wells must be located a sufficient distance from the landfill to prevent forcing air into the refuse. Spacing and depth of wells are also important.
	Treatment	Thermal Destruction	Enclosed Ground Flares	Enclosed ground flare systems consist of a refractory-lined flame enclosure. Waste is sometimes mixed with a supplemental fuel and fed through a vertical, open-ended pipe. Pilot burners next to the end of the pipe ignite the waste.	Potentially viable--however, could produce secondary air pollutants from the process.
	Monitoring	Monitoring Wells			Potentially viable.
Surface Water and Wetlands Sediments	Removal	Excavation	Mechanical Excavation	Use of mechanical excavation equipment to remove and load contaminated sediments for disposal.	Potentially viable. Potential for secondary migration of contaminants via surface water during excavation.
		Dewatering	Wells or Trenches	Temporary lowering of water table. Usually done in conjunction with sediment removal.	Potentially viable way to reduce the risk of secondary migration of contaminants during excavation.
	Disposal	Offsite Disposal/ Discharge	RCRA Landfill	Transport of excavated sediment to a RCRA permitted landfill.	Potentially viable. Treatment may be based on land disposal restrictions.
	Treatment	Physical	Stabilization	Soil mixed with stabilizing reagents (e.g., lime, fly ash) which can stabilize contaminants.	Potentially viable for sediments contaminated with inorganics and low concentrations of organics.
			Thermal Treatment	Contaminated sediments are thermally destroyed in a controlled oxygen-sufficient environment.	Potentially viable. Ash may require additional treatment for inorganics.

**Table 2-3
REMEDIAL ACTIONS USED AT LANDFILL SITES**

Environmental Media	General Response Actions	Remedial Technologies	Process Options	Description	Evaluation Comments
Surface Water	Detention and Sedimentation	Stormwater Controls	Grading Revegetation	Reshaping of topography to manage infiltration and run-off to control erosion.	Potentially viable. Usually implemented with the construction of a cap.
	Collection	Surface Controls	Pumping, Diversion, or Collection	Collection of surface water for removal, rerouting, or treatment.	Potentially viable.
	Treatment	Physical, Chemical, and Biological Treatment	See Groundwater and Leachate Process Options	Treatment of surface water using biological, chemical, or physical treatment to remove organic or inorganic contaminants. See descriptions of process options under groundwater and leachate treatment.	Potentially viable for small ponds or lagoons. Will usually be done in conjunction with treatment of groundwater or leachate.
	Monitoring	Gaging Stations		Surface water monitoring to measure flow and containment concentration.	Potentially viable.

Tables 2-4 and 2-5 present more specific RI objectives for both Phase I and Phase II fieldwork. A phase is defined as a time period where additional sample collection may be necessary to characterize a site more completely. Activities such as recontracting for services or remobilizing onto a site would be considered a separate “phase” of fieldwork. Ideally, site characterization of both sources (landfill and hot spots) and other affected media should be conducted in one phase. In some cases, however, because of the site’s complexity, Phase II sampling may be required. Phase I and Phase II sampling are often, but not necessarily, sequential. These investigations can take place on slightly different schedules or take place simultaneously, depending on the analytical turnaround time and field observations.

If sufficient information is not collected in a single phase to characterize a site adequately, it may be necessary to conduct a Phase II investigation. Phase II investigations are more frequently required for potential or existing groundwater contamination or at landfill sites with nearby wetlands and/or surface water. Phase I groundwater investigations typically estimate the plume location and may be sufficient to initiate remedial actions for plume containment. Phase II groundwater investigations typically further refine the extent of groundwater contamination and are typically used to aid in the design and implementation of the final response actions. Similarly, Phase I wetland and/or surface water investigations determine if the wetlands or surface waters are affected, while Phase II wetlands and/or surface water investigations determine the magnitude and extent of the impact. Phase II investigations for landfill contents and landfill gas are not typically done, because adequate information for characterizing these media is usually obtained from the Phase I investigation.

2.10 Development of DQOs

DQOs are qualitative and quantitative statements specifying the required quality of the data for each specific use. DQOs are based on the concept that different data uses often require data of varying quality. An example of different data uses for the

RI/FS include site characterization, risk assessment, and alternatives evaluation.

DQO development is begun during generation of the conceptual site model and further refined during definition of the preliminary remediation goals. DQOs, however, are not made final or documented until after the RI objectives have been established. There are three objectives in developing DQOs. One is to obtain a well-defined sampling and analysis plan (SAP). The SAP consists of a field sampling plan (FSP) and a quality assurance project plan (QAPP). The SAP identifies the number and types of samples to be collected, the appropriate method of analysis, and the reason the information from these samples is necessary to make necessary remedial decisions. The second objective in developing DQOs is to identify the required QA/QC procedures to ensure the quality of the data being collected. The third objective is to integrate the information required by the decision makers, data users, and technical specialists associated with the RI/FS process. This integrated approach allows for a cost-effective RI/FS implementation program.

The DQO process includes three stages for identifying the data quality needed to characterize a site adequately. The stages are:

- Stage 1. Identify decision types
 - Identify and involve decision makers, technical specialists, and other data users
 - Evaluate available information for uncertainty or adequacy for making decisions
 - Specify the RI/FS objectives and the critical decisions that would affect potential remedial actions
- Stage 2. Identify data uses and needs
 - Identify data uses and types
 - Identify data quality and quantity needs
 - Evaluate sampling and analysis options

**Table 2-4
PHASE I REMEDIAL INVESTIGATION OBJECTIVES FOR
MUNICIPAL LANDFILL SITES***

Activity	Phase I Objectives (Activities Generally Performed After Work Plan is Approved)	
	Objectives	Action
Site Mapping/Site Dynamics	Map site and determine topography; determine site boundaries, drainage patterns, and other geophysical features.	Use photogrammetric methods from aerial photography; conduct fly-over, if necessary.
Geophysical Investigation	Investigate presence of buried ferromagnetic materials (drums) where documentation and/or physical evidence indicates their presence. Determine waste fill locations and determine geologic strata.	Conduct magnetometer and/or ground-penetrating radar survey. Conduct electromagnetic conductivity survey.
Geotechnical Investigation	Evaluate the physical properties of geologic unit governing transport of contaminants. Collect data on soil characteristics to determine if onsite soil can be used as fill material and to determine placement of a potential cap or Identify offsite borrow-source for cap construction Evaluate existing cap to determine physical properties.	Collect data on permeability, porosity, hydraulic head, percent organic carbon, etc. Measure soil characteristics such as plasticity index, moisture content, porosity, and permeability. Survey local area for appropriate material. 1) Collect data on permeability, porosity, and measure thickness. 2) Determine Atterberg limits. 3) Determine extent of vegetation cover, any vegetative stress, and erosion. 4) Monitor landfill settlement (e.g., topographic survey and benchmark installation and survey).
Hydrogeologic Investigation	Determine depth of wells and screen intervals for existing shallow and deep wells. Identify and characterize hydrogeologic units.	Obtain soil classification or geologic data. 1) Drill borings around landfill for development of boring logs to better define the aquifers and confining layers; drilling through landfill contents may be conducted after evaluating health, safety, and other risks. 2) Perform down-hole geophysical surveys.

**Table 2-4
PHASE I REMEDIAL INVESTIGATION OBJECTIVES FOR
MUNICIPAL LANDFILL SITES***

Activity	Phase I Objectives (Activities Generally Performed After Work Plan is Approved)	
	Objectives	Action
Hydrogeologic Investigation (Continued)	<p>Determine direction of groundwater flow and estimate vertical and horizontal gradients.</p> <p>Determine rate of groundwater flow and evaluate the feasibility of groundwater extraction.</p>	<p>1) Install monitoring wells and take water level measurements from new and existing wells.</p> <p>2) Investigate yield of private and public wells.</p> <p>Install monitoring wells and perform hydraulic conductivity tests on new and existing wells; check water levels at a maximum of once a month during the RI.</p>
Meteorological Investigation	Determine prevailing wind direction and air speed to evaluate remedial actions.	Collect and analyze wind speed and direction data.
Chemical Investigation Groundwater	<p>Identify extent and type of groundwater contamination to perform an assessment of human health risks.</p> <p>Identify upgradient water quality for each geologic unit.</p> <p>Determine upgradient concentration.</p> <p>Determine source of groundwater contamination.</p> <p>Determine whether seasonal fluctuations occur in contaminant concentrations in the groundwater and in hydraulic characteristics.</p> <p>Evaluate feasibility of groundwater treatment systems.</p>	<p>Install monitoring well in aquifers of concern; design monitoring well network to determine the extent of the plume (wells should also be located in “clean” area to confirm that the end of the plume is located both vertically and horizontally); collect and analyze samples.</p> <p>Install upgradient monitoring wells in aquifers of concern.</p> <p>Install monitoring wells upgradient of the landfill and collect and analyze samples.</p> <p>Collect and analyze groundwater samples and compare results to the landfill waste characteristics and background levels.</p> <p>Sample and analyze groundwater during different seasons.</p> <p>Obtain COD, BOD, metals, and other conventional water quality data.</p>

**Table 2-4
PHASE I REMEDIAL INVESTIGATION OBJECTIVES FOR
MUNICIPAL LANDFILL SITES***

Activity	Phase I Objectives (Activities Generally Performed After Work Plan is Approved)	
	Objectives	Action
Leachate	<p>Identify extent and type of leachate to evaluate feasibility of groundwater treatment system.</p> <p>Estimate amount of leachate production from landfill.</p>	<p>Collect and analyze leachate data.</p> <p>Install leachate wells in or around landfill and measure leachate head.</p> <p>Perform water balance calculation on landfill.</p>
Surface Water and Sediment	<p>Determine viability of treatment technologies.</p> <p>Determine groundwater and surface water interactions during several periods during the RI.</p> <p>Determine background concentration of surface water and sediment.</p> <p>Determine surface runoff impact on surface water quality; determine the type and extent of contamination in nearby surface waters and sediments.</p> <p>Determine the absence or presence of contamination in onsite ponds.</p>	<p>Collect field measurements on Redox and DO.</p> <p>Install staff gauges onsite, survey gauges, measure surface water levels and groundwater levels concurrently.</p> <p>Collect and analyze upstream water and sediment samples.</p> <p>Collect and compare up- and downgradient surface water to downgradient groundwater samples; also collect up- and downgradient sediment samples.</p> <p>1) Collect and analyze samples from nearest leachate seeps and compare to stream water quality.</p> <p>2) Collect and analyze surface water and sediment samples at increasing distances away from the landfill and compare results to landfill waste and background levels.</p> <p>1) Collect and analyze surface water and sediment samples for onsite ponds.</p> <p>2) Conduct toxicity testing (bioassay).</p>

**Table 2-4
PHASE I REMEDIAL INVESTIGATION OBJECTIVES FOR
MUNICIPAL LANDFILL SITES***

Activity	Phase I Objectives (Activities Generally Performed After Work Plan is Approved)	
	Objectives	Action
Landfill Gas/Air	Identify areas within the landfill containing high concentrations of explosive or toxic landfill gas to perform an assessment of human health risks due to air toxics and explosive hazards, to evaluate the feasibility of gas collection and treatment, to evaluate need for immediate action, and to evaluate other remedial actions.	1) Obtain flow-related data from existing and newly installed gas vents, estimate emission rates, and perform air modeling. 2) Obtain samples of landfill gas from within the landfill using the leachate headwell.
	Estimate concentrations of selected VOCs being emitted to the atmosphere.	Collect and analyze ambient air samples.
Landfill Gas/Groundwater	Identify areas within the landfill containing high concentrations of explosives or toxic landfill gas to determine if VOCs act or may act as a source of groundwater contamination.	Obtain flow-related data from existing and newly installed gas vents, estimate emission rates, and perform air modeling.
Hot Spots	Investigate areal extent, depth, and concentration of contaminants at hot spots in the landfill's contents.	Collect and analyze samples from potential hot spot areas (documentation and/or physical evidence must exist to qualify hot spot as "potential"), with more extensive sampling within confirmed hot spot areas.
Environmental Evaluation	Delineate wetlands. Determine impact of landfill on nearby wetlands. Describe aquatic and terrestrial community in vicinity of site and aquatic community downstream of site. Determine impact of remedial action on wetlands/flood plains.	Conduct wetlands delineation survey. Collect and analyze surface water and sediment from nearby wetlands. Collect or observe aquatic or terrestrial organisms in the vicinity of the site; conduct sensitive receptor survey. Delineate wetlands/flood plain areas in vicinity of site.

*Refer to Section 2, Site Characterization Strategies, for an explanation of when these activities are appropriate.

**Table 2-5
PHASE II REMEDIAL INVESTIGATION OBJECTIVES FOR
MUNICIPAL LANDFILL SITES***

Activity	Phase II Objectives (Activities Generally Performed After Work Plan is Approved)	
	Objectives	Action
Geophysical Investigation	Further investigate probable presence of buried ferromagnetic materials (drums).	Excavate probable drum burial area.
Geotechnical Investigation	Further evaluate the physical properties governing transport of contaminants through identified pathways.	Collect additional data on permeability, porosity, hydraulic head, percent organic carbon, etc.; model pathways.
Hydrogeologic Investigation	<p>Determine depth of wells and screen intervals for existing shallow and deep wells.</p> <p>Further identify and characterize hydrogeologic units.</p> <p>Further determine direction of groundwater flow and estimate gradients.</p> <p>Determine rate of groundwater flow and evaluate the feasibility of groundwater extraction.</p>	<p>Obtain additional soil classification or geologic data; review Phase I RI results.</p> <p>1) Drill additional borings throughout site for development of boring logs to better define the aquifers and configuring layers (health, safety, and long-term risk associated with drilling into the landfill should be weighed against the potential usefulness of the data for evaluating alternatives).</p> <p>2) Perform down-hole geophysical surveys, as appropriate.</p> <p>Install additional monitoring wells and take water level measurements from new and existing wells.</p> <p>Install monitoring wells and perform hydraulic conductivity and pumping tests on new and existing wells; check water levels at a maximum of once a month during the RI.</p>
Chemical Investigation Groundwater	<p>Identify extent and type of groundwater contamination to delineate plume.</p> <p>Redetermine upgradient concentration if Phase I results inconclusive</p> <p>Further determine whether seasonal fluctuations occur in contaminant concentrations in the groundwater and in hydraulic characteristics.</p> <p>Further evaluate feasibility of groundwater treatment systems.</p>	<p>Install additional monitoring wells in aquifers of concern; collect and analyze samples.</p> <p>Install additional monitoring wells upgradient of the landfill and collect and analyze samples.</p> <p>Sample and analyze groundwater with additional rounds of sampling from the same location(s).</p> <p>Obtain additional COD, BOD, and other conventional water quality data; initiate treatability studies, as necessary.</p>

**Table 2-5
 PHASE II REMEDIAL INVESTIGATION OBJECTIVES FOR
 MUNICIPAL LANDFILL SITES***

Activity	Phase II Objectives (Activities Generally Performed After Work Plan is Approved)	
	Objectives	Action
Surface Water and Sediment	<p>Further determine effect of groundwater on surface water.</p> <p>Compare additional stream and water levels during several periods during the RI.</p>	<p>Collect and compare additional up- and downgradient surface water and sediment samples to downgradient groundwater samples.</p> <p>Install additional staff gauges onsite, survey gauges, measure surface water levels and groundwater levels concurrently.</p>
Landfill Gas/Air	<p>If initial results are inconclusive, identify additional areas within the landfill containing high concentrations of explosives or toxic landfill gas to perform an assessment of human health risks due to air toxics and explosive hazards, to evaluate the feasibility of gas collection and treatment, and to evaluate other remedial actions.</p>	<p>Obtain additional flow-related data from existing and newly installed gas vents, estimate emission rates, and perform air modeling.</p>
Landfill Gas/Groundwater	<p>If initial results are inconclusive, identify additional areas within the landfill containing high concentrations of explosives or toxic landfill gas to determine if VOCs act or may act as a source of groundwater contamination.</p>	<p>Obtain additional flow-related data from existing and newly installed gas vents, estimate emission rates, and perform air modeling.</p>
Environmental Evaluation	<p>Describe aquatic and terrestrial community in vicinity of site and aquatic community downstream of site on a seasonal basis.</p>	<p>Collect or observe aquatic or terrestrial organisms in the vicinity of the site on a seasonal basis.</p>
<p>*Refer to Section 2, site Characterization Strategies, for an explanation of when these activities are appropriate.</p>		

- Review precision, accuracy, representativeness, completeness, and comparability (PARCC) parameters
- Stage 3. Design data collection program
 - Assemble data
 - Design program

Although the elements of Stage 1 can be thought of as distinct steps, they are continuous, incorporating additional information as it becomes available. DQOs should be undertaken in an interactive and iterative manner; DQO elements are continually reviewed and evaluated as data are compiled.

The output of the DQO process is a well-defined SAP, with summary information provided in the project work plan. Documentation is supplied, detailing the type of samples believed to be necessary for each matrix to obtain sufficient representation of site conditions. The desired PARCC of the chemical analyses are also documented.

Before the DQOs are developed, a detailed list of potential ARARs specifying the required chemical concentrations should be prepared. In addition, a preliminary risk assessment may be conducted and chemical concentrations relating to a 10^{-4} to 10^{-6} risk range should be determined. The purpose of the ARARs and risk assessment information is to determine the contaminants of concern and the required analytical detection limits. These ARARs should include both federal and state requirements, because some states may have their own more stringent standards. The detection limits noted during the assembly of the ARARs should be incorporated in the DQOs.

A combination of laboratory services may be used to achieve the DQOs so that time and money are used efficiently. There are five levels of data methodologies and associated quality control that can be used during an RI:

- Level I is the lowest quality data but provides the fastest results. Field screening or analysis provides Level I data. It can be used for health and safety monitoring and preliminary screening of samples to identify

those requiring confirmation sampling (Level IV). The generated data can indicate the presence or absence of certain constituents and is generally qualitative rather than quantitative. It is the least costly of the analytical options.

- Level II data are generated by field laboratory analysis using more-sophisticated portable analytical instruments or a mobile laboratory onsite. This provides fast results and better-quality data than in Level I. The analyses can be used to direct a removal action in an area, reevaluate sampling locations, or direct installation of a monitoring well network.
- Level III data may be obtained by a commercial laboratory with or without CLP procedures. (The laboratory may or may not participate in the CLP.) The analyses do not usually use the validation or documentation procedures required of CLP Level IV analysis. The analyzed parameters are relevant to the design of the remedial action.
- Level IV data are used for risk assessment, engineering design, and cost-recovery documentation. All analyses are performed in a CLP analytical laboratory and follow CLP procedures. Level IV is characterized by rigorous QC protocols, documentation, and validation.
- Level V data are those obtained by nonstandard analytical procedures. Method development or modification may be required for specific constituents or detection limits.
- Other. This category includes data obtained from analyses of the physical properties of soil, such as Atterberg limits and soil moisture.

Tables 6-1 through 6-3 in Appendix A of this report present an example of a DQO summary for an example landfill site. The analytical levels are mixed to provide an optimal analytical program. For example, in the case of

groundwater, Level I data can consist of screening for volatile organic compounds (VOCs) using a photoionization detector, and Level III can be obtained from analyzing for parameters needed for treatment such as iron and manganese. Level II data can consist of analysis of the groundwater by an onsite mobile laboratory. Placement of the monitoring wells can then be readjusted in the field, if necessary. Level IV data would provide the results of site characterization and risk assessment. Level V data would be obtained for chemicals such as vinyl chloride (for vinyl chloride, the detection limit required for risk assessment, based on a 10^{-6} cancer risk, is lower than the detection limit established in CLP methodology).

The first phase of DQO development is complete once the field program has been defined. The RI tasks necessary to achieve the DQOs must be specified in the work plan and may be altered or redefined, depending on the results of fieldwork. Additional information on DQOs can be found in

the documents titled *Data Quality Objectives for Remedial Response Activities*, Volumes I and II (U.S. EPA, 1987b and U.S. EPA, 1987c).

2.11 Section 2 Summary

This section illustrates the key components of scoping an RI/FS for a CERCLA municipal landfill site. The primary purpose of scoping an RI/FS is to divide the broad project goals into manageable tasks that can be performed within a reasonable period of time. The broad project goals for an RI/FS at any Superfund site are to provide the information necessary to characterize the site, define site dynamics, define risks, and develop a remedial program to mitigate potential adverse public health and environmental impacts. To obtain the necessary data to achieve these goals, Section 3 presents various site-characterization strategies and the associated field tasks for municipal landfill sites.

Section 3

SITE CHARACTERIZATION STRATEGIES

Once a work plan has been developed, field activities are undertaken to further characterize the site. The purpose of site characterization is to assess the risks to human health and the environment posed by the site and to develop a remediation strategy to mitigate these current and potential threats.

As described in Section 2, site characterization begins with an evaluation of previous data and analytical results. This information is combined with field investigations to fill in data gaps and to test hypotheses about the site developed during scoping. In this section, characterization activities are described by the different media that might be contaminated by a municipal landfill site, and different site characterization strategies for two types of municipal landfill sites are discussed.

Most municipal landfill sites on the NPL are co-disposal facilities that may or may not have known or suspected hot spots. Hot spots consist of highly toxic and/or highly mobile material and present a potential principal threat to human health or the environment (see 40 CFR Sec. 300.430(a)(1)(iii)(C)). Excavation or treatment of hot spots is generally practicable where the waste type or mixture of wastes is in a discrete, accessible location of a landfill. A hot spot should be large enough that its remediation will significantly reduce the risk posed by the overall site, but small enough that it is reasonable to consider removal and/or treatment.

The two principal types of municipal landfills are as follows:

- Landfill Type I. This is a co-disposal facility where records or some other form of evidence indicate that hazardous wastes were disposed of with municipal solid wastes. There are no known or suspected hot spot areas, and historical records and physical evidence, such as aerial photographs and the site visit, do not document any discrete subsurface disposal areas.

- Landfill Type II. This is a co-disposal facility where approximate locations of hot spots are known or suspected, either through documentation, physical evidence, or consistent employee/resident interviews. Small- to moderate-sized landfills (for example, less than 100,000 cubic yards) that pose a principal threat to human health and the environment are included in this group because it may be appropriate to consider excavating and/or treatment of the contents of these landfills.

Placing municipal landfill sites into these two categories allows more efficient characterization through avoidance of extensive and unnecessary sampling, and streamlines the RI/FS process. It should be noted that the distinction between these landfill types will not always be clear. Therefore, the application of the approaches described below should be flexible and adapted to the specific site characteristics.

In general, categorizing landfills into different types allows the site characterization to focus on detecting and then characterizing hot spots. Because there are no known or suspected hot spots, the feasibility study for Landfill Type I can focus on capping alternatives as part of an operable unit. This focused feasibility study could precede or be conducted concurrently with the groundwater investigation, particularly at sites where leachate is not a problem. At Landfill Type II, more effort can be expended on characterizing and remediating the hot spots. At these sites, the feasibility studies can focus on the operable units and remedial action alternatives for these units.

Site characterization strategies for the landfill types are described below by medium. The focus of the descriptions is primarily on those media most often requiring remediation at municipal landfill sites (e.g., groundwater, leachate, landfill contents/hot spots, and landfill gas). Other areas such as wetlands, surface water, and sediments are also discussed, but in less detail, since the nature of contamination is not unique

to municipal landfill sites and information is readily available from other sources. The descriptions were prepared as if the site investigations were done in only one medium. However, at most sites, this will not be the case. The user should read all descriptions applicable to the site, and coordinate sampling and investigation efforts as described in Section 2.10, Development of DQOs. Sample requirements should be reviewed in all media of concern to determine the most efficient and concise method of obtaining data.

Site characterization efforts may generate a large amount of data. Organization of the data is essential to proper interpretation. During planning of surveys or well installations, consideration should be given to data organization--mapping, geologic cross sections, grid points, etc.--as well as to organization of results from field instrument analyses.

3.1 Groundwater

Characterizing a site's geology and hydrogeology as well as developing an understanding of the regional geology and hydrogeology is paramount to the site characterization process. Data gathered for site characterization of geology and hydrogeology significantly affect the selection of an appropriate remedial action strategy. The type of cap selected, the location of the groundwater extraction system and amount of groundwater extracted, and the necessity for collecting and treating landfill gas are all affected by the geology and hydrogeology of the site. General procedures for Phase I and Phase II site characterizations of regional and site-specific geology and hydrogeology are described below. More specific information on placement of monitoring wells by landfill type is given in Section 3.1.3.

All Phase I and Phase II characterization activities can be done at both types of landfill sites. Depending on the type and quality of data gathered both before and during development of the RI/FS work plan, some of these activities may have been performed. Further information on characterizing site hydrogeology is available in *Guidance on Remedial Actions for Contaminated Groundwater at Superfund Sites* (U.S. EPA,

1988e).

3.1.1 Groundwater Investigations

The characterization of the groundwater beneath and near a site is often completed in two phases. The initial site characterization study is based on a review of existing literature describing the regional and local geology and site history. This literature includes local government records and aerial photographs. The second phase is based on the review of existing literature and is used to design a sampling and monitoring program to answer questions developed during the first phase.

The initial characterization of the hydrogeology and the groundwater conditions (done before or during the limited field investigation) depends on an understanding of the relationship of the site geology and groundwater flow characteristics. At a minimum, a description of the site geology should include the lithology of geologic units underlying the site that are contaminated or used as Class I or II aquifers, and the relationship among the units.

3.1.1.1 Phase I Site Characterization

In Phase I, geological information about the area, gathered during the limited field investigation, and intrusive activities such as drilling and geophysical surveys (described in further detail in Section 3.2) is reviewed. The data gathered for the Phase I site characterization should be sufficient to provide a general understanding of the hydrogeological regime of the region and its relationship to the landfill. The information should give a general picture of the local stratigraphy, depositional environments of the strata, the tectonic history as it relates to tilting, folding, or fracturing of the strata present, groundwater depth and flow direction, the units that are contaminated or used as Class I or II aquifers, and local groundwater uses, including the effects of pumping (withdrawal). After this information has been gathered and reviewed, a regional conceptual model of the Hydrogeology should be developed (see Section 2.5). Future field investigations are based on this model and are developed to fill in the data gaps and to answer hypotheses presented by the model.

This conceptual model is revised as new information is developed from the field investigation.

A limited number of boreholes with wells and piezometers monitoring discrete water-bearing zones should be installed during the Phase I site characterization. For characterization purposes, it may be useful if at least one borehole is drilled into the first confining layer beneath the uppermost aquifer (water table or unconfined aquifer). Boreholes and monitoring wells should be drilled at the site in numbers and locations sufficient to characterize the geology, water levels, and groundwater flow beneath the site. Sufficient borings and wells should be installed to permit the construction of meaningful geologic cross sections. The density of data points should describe the relationships between geologic and hydrologic conditions. For example, if groundwater flow is controlled by fractures in tilted strata, a sufficient number of wells should intersect or cross the fractured strata.

Information derived from the borings should be sufficient to:

- Correlate stratigraphic units
- Identify zones of possible high hydraulic conductivity
- Identify confining layers
- Identify any unusual or unexpected geological features such as faults, fractures, facies changes, solution channels, etc.

In some cases, samples should be collected to test for geotechnical and geochemical parameters. Tests could include cation exchange capacity if metals contamination is expected, bulk density and moisture content for treatment characteristics, permeability and porosity for containment or extraction effectiveness, and analytical parameters (e.g., TAL metals, TCL organics) for contaminant fate and transport.

Each boring should be documented with a boring log that describes:

- Soil classifications or rock types

- Structural features such as fractures and discontinuities
- Depth to water
- Depth of boring and reason for termination
- Development of soil zones and vertical extent
- Any evidence of contamination
- Geotechnical information such as blow counts, color, grain-size distributions, and plasticity
- Well construction details (if boring is finished as a monitoring well)

At least the first borehole should be sampled continuously to determine if the subsurface materials are variable. Samples should be collected from every significant stratigraphic contact and formation, especially the confining layers. Subsequent borings may be sampled at predetermined intervals that are justified based on the subsurface characteristics. All boreholes in which piezometers or monitoring wells are not installed must be properly abandoned. Soil samples should be described by a qualified geologist, geotechnical engineer, or soil scientist.

Groundwater quality samples that identify the extent and type of contamination should be collected in the aquifer of concern. The aquifer of concern is the unit where contamination is known or suspected or one that is used as a Class I or II aquifer. Upgradient water quality for the aquifers of concern should also be established. Seasonal fluctuations in contaminant concentrations should be determined. Well pairs may be required to determine the vertical direction of flow between the water table and a lower aquifer. The deep well of the pair can also determine if the contamination has entered a lower aquifer. Wells penetrating lower aquifers must be constructed with care so that they do not become conduits for contamination. If such wells are intended only to determine the hydraulic relationship between two aquifers, they should not be placed downgradient from a potential contaminant source. They should only

be placed downgradient from a source if the hydraulic relationships of that area may be different than at other locations or if contamination is suspected or documented.

The Phase I site characterization should be flexible to accommodate revisions to the scope as information becomes available. For example, groundwater sampling results may be obtained with a fast turnaround time during the Phase I field activities. This would allow refining the investigation program in the field to delineate contamination and possibly limit the need or extent of a Phase II investigation.

3.1.1.2 Phase II Site Characterization

Phase II site characterization is warranted if the data obtained in Phase I are insufficient to assess risks to human health and the environment and to develop and evaluate remedial action alternatives. If the information obtained in Phase I cannot answer questions on the direction and rate of groundwater flow, effectiveness of an observed or presumed aquiclude, extent of observed contamination, or location of known or presumed contamination, a Phase II site characterization is necessary. For instance, descriptions from the boring logs may indicate that a confining layer is possibly continuous across the site, but aquifer tests or analytical data indicate that the confining layer is discontinuous. In this case, additional borings, wells, and aquifer tests may be necessary to resolve the conflicting data.

Phase II site characterizations are also necessary if previously unknown hot spots are detected during the Phase I site activities and additional borings or wells are beyond the capability of the driller. Data should be obtained during Phase II site characterization activities to place the hydrogeology of known and newly discovered hot spots in context with the geology of the site and region.

During this phase, the compatibility of the naturally occurring clay minerals and other rock and soil-forming materials with any known chemicals in the landfill should be examined. Soil and rocks with a high carbonate content will be attacked by acids, increasing their permeability. Clays similar to bentonite can be ineffective barriers to the migration of some organic compounds. Laboratory

determination (X-ray diffraction) of the clay types may be necessary.

Data gathered during Phase II site characterization activities should primarily be directed towards identifying potential targets and optimizing the analytical program. Additional monitoring wells should be installed, and groundwater and leachate samples should be collected from areas where Phase I activities indicate that contamination has spread or is spreading. Sampling in “clean” areas should be minimized unless Phase I activities did not adequately define these areas. Monitoring wells are needed to identify the limits of the plume, and as such, would be at the end of the plume in areas considered “clean.” Additional piezometers can be installed if groundwater and leachate rate and flow direction need to be clarified for modeling and descriptive purposes.

If the necessary characterization is largely done during Phase I activities, then fewer boreholes and less additional indirect investigation will be necessary during Phase II activities. Placement of boreholes, piezometers, and monitoring wells should be carefully reviewed so that essential information on leachate and groundwater is collected. Drilling an excessive number of boreholes will not necessarily provide useful information on the site’s hydrogeology. Additional information on placement of monitoring wells is provided in Section 3.1.3.

3.1.2 Data Requirements

A detailed description of groundwater remedial action alternatives for municipal landfill sites can be found in Section 4.5. To evaluate the various remedial action alternatives, data gathered before or during the site characterization of groundwater should include:

- The regional geologic regime and regional groundwater flow direction
- A hydrogeologic investigation to characterize the groundwater aquifer including the depth to water, flow direction, flow rate, the extent and nature of confining layers, fractures, and any potential pathways for contaminant migration at the site

- Location of site-specific items of interest such as outcrops, springs, seeps, leachate outbreaks, and surface drainage features
- The compatibility of the suspected contaminants with naturally occurring materials at the site
- Identification of actual or potentially useable aquifers (e.g., Class I and Class II aquifers) and water-bearing units and their physical properties (including linkage between aquifers)
- Climatic and topographic conditions affecting groundwater recharge and discharge, erosion, flooding, and surface water conditions of interest
- Identification of potential pathways for contaminant migration
- Geologic conditions, hazards, or constraints that could contribute to offsite contaminant migration or that might preclude certain remedial alternatives
- Site-specific analysis such as BOD and COD (see Section 4.5)

3.1.3 Placement of Monitoring Wells

3.1.3.1 Objectives

The objective of installing monitoring wells is to determine if the landfill has affected the groundwater system. Monitoring wells are used to:

- Determine subsurface conditions, including confining layers and zones of high permeability
- Determine background (upgradient) water quality
- Locate contaminant plumes
- Characterize groundwater contaminants
- Characterize hot spots

Because there are many uses for monitoring wells at municipal landfill sites, there are no simple procedures for determining appropriate placement. Simple geology characterized by horizontal, thick, homogeneous, unfractured strata tends to reduce the number of soil borings and monitoring wells. More complicated geology, including fractured, tilted, folded, thin, or heterogeneous geologic strata tends to increase the number of soil borings and monitoring wells necessary to adequately characterize a site. Landfill conditions that lead to more detailed investigations include known locations of the disposal of hazardous wastes and loss of containment (liner or slurry wall) integrity.

3.1.3.2 Procedures

Landfill Type I. This is a municipal landfill where co-disposal of hazardous and municipal wastes occurred, but the disposal in a discrete, accessible location of highly toxic and/or highly mobile material that presents a potential principal threat to human health or the environment, is not known. The presence of hazardous constituents in the groundwater is a concern at this type of landfill. The number of wells should be determined on a site-specific basis.

Upgradient Monitoring Wells. The number of wells increases with the complexity of site geology and landfill design or history. Upgradient monitoring wells should be in a “clean” area so that they may provide representative background groundwater quality in the aquifer of concern. They should be screened in the same strata as the downgradient monitoring wells unless the bedrock dips steeply or rock types change rapidly across the site. Location of the monitoring wells should also consider groundwater and contaminant velocity at the site. Groundwater that moves slowly and where the contaminants are widely dispersed will require careful location of upgradient wells to avoid the plume. The location of upgradient monitoring wells should consider surface water or agricultural and industrial activities that may be affecting the groundwater quality upgradient of the landfill. A preliminary estimate of contaminant travel distances should be determined so initial well installation approaches can be determined.

Downgradient Monitoring Wells. Downgradient monitoring wells should be near the landfill boundary and in the saturated zone. If the landfill lies above the saturated zone, the leachate migration pathway to the groundwater should be considered before monitoring well placement is determined. In cases where complex interbedding, especially of alluvial deposits, underlie the landfill, additional monitoring wells may be required. It should also be recognized that glacial stratigraphy can also be very complex.

Downgradient monitoring wells should be located along any zone that may offer preferential groundwater movement. Geologic features such as solution channels, faults, or permeable linear sand lenses should also be considered in downgradient monitoring well placement, since these features can act as groundwater conduits. Other features that affect the placement of downgradient monitoring wells include fill areas, buried pipes and utility trenches, areas with high hydraulic gradients, and areas with high groundwater velocities. Placement of downgradient monitoring wells should also consider low-permeability zones associated with such features as clay lenses, dense bedrock, and glacial till that can differentially retard groundwater flow.

The use of field data or rapid turnaround data from a nearby laboratory can provide useful information in the placement of monitoring wells. For example, an onsite laboratory could be used during well installation to provide analytical results that would be used to reevaluate the proposed monitoring well network. Groundwater samples could be analyzed for selected VOCs and inorganic anions to aid in determining the extent of the groundwater plume. Inorganic anions such as chloride and sulfate are persistent chemicals that can be used as indicators of contaminant transport. Therefore, mapping elevated levels of these indicator chemicals relative to upgradient concentrations can give a more accurate picture of the extent of the groundwater plume than just VOC analysis. Because of volatilization, adsorption, and degradation, VOCs may diminish in concentrations more rapidly than the inorganic ions.

Other Monitoring Wells. Additional monitoring wells need to be installed and sampled to determine the integrity of any confining layers and to determine whether the confining layer is continuous or breached. Where a confining layer exists, monitoring wells should be installed in the area in order to assess vertical flow between the upper and lower aquifer, and the groundwater flow in the lower aquifer. In general, numerous boreholes or wells through confining layers should be avoided when the site conceptual model indicates a very low potential for contamination of the underlying aquifer.

Monitoring Well Screen Placement. Monitoring wells should be completed in the first aquifer encountered beneath the landfill and other discrete zones beneath. That aquifer will usually be unconfined at the landfill location. The nature of the suspected contaminants should be used to determine the ideal screen location in the aquifer. Most typical landfill contaminants are soluble enough to be detected by laboratory instruments, so screening in the upper portion of the aquifer should detect any contamination present.

If a highly variable geology exists at the site, each screen should be open only to one stratum. If a screen is open to more than one stratum, contaminants may move to uncontaminated zones, and the actual zone of contamination will be impossible to determine. A typical screen length is 5 feet, but longer screen lengths are required in zones of very low permeability or where water levels are known to change over great intervals. Generally, screens should be no longer than 20 feet.

If the contaminant is a dense, non-aqueous phase liquid (DNAPL), the screens must monitor the bottom of the first aquifer. If this distance is excessive, several monitoring wells with overlapping screens are typically installed. DNAPL migration is generally controlled by the top surface of the confining layer, and is little affected by the hydraulic gradient. Additional monitoring wells and boreholes may be required to define this surface. A DNAPL will enter deeper aquifers if breaches in the confining layer are encountered. DNAPLs may move through clays at order-of-magnitude greater velocities than water. Monitoring wells should

be placed in the lower aquifer to determine the hydraulic gradient between the two aquifers, and to determine if contamination has reached the lower aquifer. DNAPLs can migrate to the bottom of the lower aquifer, but often this distance is great and the nature and topography of the underlying aquitard are difficult to define.

The viscosity and dispersivity of the contaminant should also be considered during monitoring well screen placement. A highly viscous liquid will migrate very slowly in the subsurface. Its movement may be affected more by capillary attraction than by normal factors of gradient and hydraulic conductivity. A highly dispersive compound, on the other hand, can migrate quickly by dispersion and extend downgradient much faster than the gradient and hydraulic conductivity indicate.

Organic contaminants that are less dense than water may be detected with screens that extend from at least 5 feet above the saturated zone to about 15 feet into the saturated zone. This detects any floating, non-aqueous phase contaminants. Screen openings should be confined to a single stratum.

Landfill Type II. The principal concern at this type of landfill is the known or suspected hot spots. Monitoring well and screen placement described for Landfill Type I can be employed, but additional monitoring wells should be placed downgradient of all confirmed hot spots. (The presence of hot spots is confirmed using the geophysical survey procedures described in Section 3.2.)

Hot spots should be treated as unique sites within the landfill. The hot spot may be isolated with up- and downgradient monitoring wells within the landfill. Test pits should be installed in such areas to investigate the subsurface materials. This will restrict remediation to a smaller area. Care must be exercised because drilling through the landfill to install the monitoring wells could compromise the integrity of any liners, puncture isolated drums, or penetrate a gas pocket, causing an explosion hazard. Also, because of the nature of landfill material, the integrity (or quality) of sampling locations within the landfill is unknown.

3.1.3.3 Guidelines

The summary documents presenting the data should contain concise, narrative descriptions of the data but must rely on clear, detailed figures to present the spatial relationships of groundwater, geology, and the landfill. Geologic cross sections based on the boring logs must depict all significant soil and rock units, geological structures, zones of high permeability and confining layers present, and the depth to water and the unconfined and confined water levels. The locations of all borings should be displayed on an appropriate map. The lines of the cross sections should be shown, and surface features should be located on the cross sections.

A map showing the monitoring well locations should also be prepared. The map can display water levels and develop water level contours and show groundwater flow direction, groundwater divides, recharge, and discharge areas. In cases where more than one aquifer exists, the map can also be used to show the direction of vertical groundwater flow.

3.1.4 Groundwater Summary

Table 3-1 summarizes the conditions that determine monitoring well locations and numbers. A flowchart summarizing the decisions necessary to determine sampling and monitoring locations is presented in Figure 3-1. The decision points illustrated across the top of the figure must be considered separately in determining monitoring well placement. For instance, a determination of where to place upgradient monitoring wells does not eliminate decisions on where to place wells to characterize zones of permeability.

The Phase I and Phase II site characterizations apply to both landfill types as well as other NPL sites. Placement and number of monitoring wells vary according to the size of the site, the geology of the area, and the type of landfill.

3.2 Leachate

The main factor contributing to leachate quantity is infiltration. However, other factors--

**Table 3-1
CONDITIONS THAT DETERMINE MONITORING WELL LOCATION AND NUMBERS**

Conditions	Monitoring Well Location	Number of Monitoring Wells
Landfill in saturated zone	Downgradient near landfill boundary but along zones of high hydraulic conductivity, including hot spots. OR If no zones of high permeability, near downgradient boundary of landfill or near confirmed hot spot.	High. Moderate.
Landfill above saturated zone	Possibly at some distance from downgradient landfill boundary or hot spot--depends on subsurface features controlling fluid movement in vadose or saturated zone. OR If homogeneous geology, downgradient in uniform array.	High. Moderate to high.
Landfill in vadose zone	Intercept leachate downgradient.	Moderate.
Interlayered confining layers	Top of each confining layer downgradient.	At least one per confining layer.
Breached or continuous confining layer	Top of confining layer and in next lower aquifer downgradient.	At least two.
No upgradient contaminant source	Upgradient of landfill boundary--distance depends on groundwater velocity and contaminant dispersivity--in same strata as monitoring wells on downgradient side of landfill or as required by geology.	Relatively few--at least one, probably more.
Upgradient contaminant sources	Near potential source and upgradient of landfill and downgradient of source--in same strata as monitoring wells on downgradient side of landfill or as required by geology.	One per source and per strata.

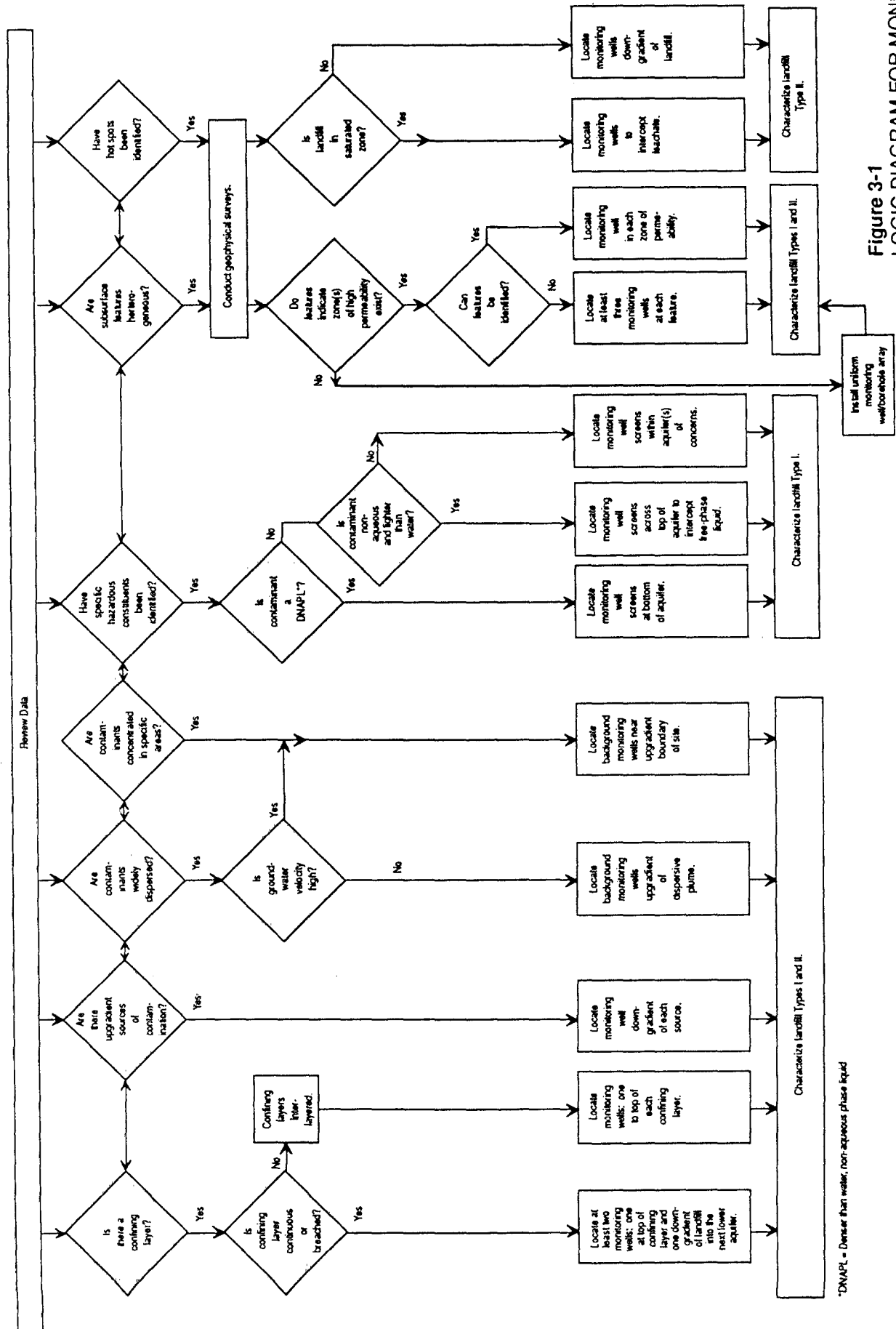

Figure 3-1
LOGIC DIAGRAM FOR MONITORING
WELL AND SCREEN PLACEMENT

*DNAPL = Denser than water, non-aqueous phase liquid

including groundwater and surface water recharge and the water generated as part of refuse decomposition—all contribute to the quantity of leachate generated. Leachate production generally follows a cyclic pattern depending on local rainfall, runoff, and evapo-transpiration rates. Leachate typically carries many suspended and dissolved materials; the specific nature and concentration depend on the landfill history as well as its degradation stage. Typical leachate concentration ranges are presented in Table 3-2. The large ranges presented may be due in part to analysis of leachate diluted by groundwater. Additional information on leachate composition and contaminant concentrations in leachate can be found in *Characterization of MWC Ashes and Leachates from MSW Landfills, Monofills and Co-Disposal Sites* (U.S. EPA, 1987f).

Leaching is a contaminant release mechanism, potentially transporting contamination to onsite and offsite groundwater through groundwater movement, or to onsite surface water, sediments, and nearby wetlands by recharging due to leachate seeps. Leaching is usually the contaminant release method of greatest concern at landfill sites.

3.2.1 Leachate Investigations

3.2.1.1 Objectives

The objectives of leachate investigations are to:

- Determine location of leachate seeps
- Determine chemical characteristics of leachate
- Locate potential source areas (in situations where there are no known or suspected hot spots, the entire landfill may be considered a source)
- Determine leachate impact on groundwater

Leachate samples may be analyzed to confirm or complement data obtained from analysis of groundwater and soil samples.

3.2.1.2 Procedures

Landfill Type I Type I landfills include those landfills where a combination of municipal and hazardous wastes have been co-disposed. At these types of landfills, discrete hot spot locations are neither known nor suspected. At these sites, a water balance identifying water sources and discharges should be performed for the entire site to estimate annual leachate production. Leachate collection locations should be identified for sampling. The location where leachate discharges ultimately depends on the site's physical and geological characteristics. In most cases, at least part of the leachate that discharges from the landfill migrates into the underlying groundwater system. In this case, leachate acts as groundwater recharge and its detection and collection can become very difficult. The actual zone depends on the permeabilities of the materials involved and in their specific gravities, mixing (turbulent versus laminar flow), and diffusion. Where underlying refuse, soil, or rock strata are impervious, leachate will discharge on the surface either at the landfill toe or somewhere on the slopes.

At both landfill types, it may be necessary to sample the surface waters. Leachate can move laterally below ground toward a creek or stream, affecting the water quality. Samples should be collected both upstream and downstream of the site to monitor this situation properly. At other sites in which the refuse is deposited on impervious clays and in areas of high precipitation, the leachate can outcrop at the top and sides of the fill and flow with the surface runoff directly to a receiving water body. Samples should be collected at the leachate seep and upstream of the seep.

When a number of seeps are present in the same area, compositing of samples from these seeps may be appropriate in some limited cases. The advantage of compositing is that the costs of analysis, data validation, and database activities are lowered while not eliminating sampling of any of the seeps. The disadvantage is that information on the individual seeps is not available. Compositing would not be appropriate if significant differences in leachate composition are expected.

Table 3-2*
**RANGE OF TYPICAL DOMESTIC REFUSE
 LEACHATE CONSTITUENT CONCENTRATIONS**

Constituent	Concentration Range Per Liter (mg)
Iron	200 - 1,700
Zinc	1 - 135
Arsenic	0 - 70
Lead	0 - 14
Phosphate	5 - 130
Sulfate	25 - 500
Chloride	100 - 2,400
Sodium	100 - 3,800
Nitrogen (Kjeldahl)	20 - 500
Hardness (as CaCO ₃)	200 - 5,250
COD	0 - 750,000
BOD	9 - 55,000
TOC	5 - 30,000
TDS	0 - 51,000
TSS	2 - 140,000
Total Residue	1,000 - 45,000
Nickel	0.01 - 0.8
Copper	0.10 - 9.0
pH	4.00 - 8.5

**From Characterization of MWC Ashes and Leachates from MSW Landfills, Monofills, and Co-Disposal Sites (EPA, 1987f)*

When collecting samples, field observations can be used to determine if samples from adjacent locations can be composited into one representative sample. Samples from leachate seeps that are near each other can be composited if they 1) are similarly colored, 2) have similar liquid phases, and 3) appear similar when scanned with field instruments. Samples from opposite sides of the landfill should not be composited. Further information on leachate sampling methods is available in Volumes I and II of EPA's *A Compendium of Superfund Field Operations Methods* (EPA, 1987h).

If available, samples should also be collected from leachate collection drains and/or extraction wells using pumping or bailing, except for VOCs, which must be collected using a bailer. Samples should be analyzed for priority pollutant organics and metals and cyanide. Other parameters, such as BOD, COD, pH, TDS, TSS, oil and grease, TOC, chlorides, nitrite, nitrate, ammonia, total phosphorus, and sulfides should be analyzed to provide data for design of a leachate treatment system.

In many landfills, leachate is perched within the landfill contents, above the water table. In the absence of leachate collection systems at Landfill Types I and II, leachate wells installed into the landfill, as part of the site characterization, may provide good hydrologic information on the site. That is, placing a limited number of leachate wells in the landfill is an efficient means of gathering information regarding the depth, thickness, and types of the waste; the moisture content and degree of decomposition of the waste; leachate head levels and the composition of landfill leachate; and the elevation of the underlying natural soil layer. Additionally, leachate wells provide good locations for landfill gas sampling. Leachate wells should not be placed where there are existing leachate collection systems, to prevent possible damage to these structures. In addition, it should be noted that, without the proper precautions, placing wells into the landfill contents may create health and safety risks. Also, installation of wells through the landfill base may create conduits through which leachate can migrate to lower geologic strata. And finally, the installation of wells into landfill contents may make it difficult to ensure the reliability of the

sampling locations.

The number of leachate wells will vary for each landfill. In cases where the refuse is fairly thick, clusters or nested wells may be appropriate to determine if leachate composition varies with depth. Samples should be analyzed for parameters previously described.

Landfill Type II. Type II landfills differ from Type I landfills in that there is evidence of hot spot areas. In these cases, treatment of hot spots may be a way of reducing the amount and concentration of leachate generated. As with Landfill Type I, a water balance for the entire site should be performed to estimate annual leachate production.

At landfills that are suspected or known to contain hot spots, leachate wells should not be used as a substitute for test pits and actual waste sampling. However, chemical analyses of the leachate may demonstrate a principal threat to the groundwater or surface water systems not observed from analysis of environmental samples showing lower concentrations.

For any sample collection method used, more than one round of sampling is recommended to characterize the leachate properly. A minimum of two sampling events, one during a dry period and the second during or immediately after precipitation, should be performed to determine variability in leachate composition.

3.2.1.3 Guidelines

Field screening techniques described in Section 3.3.1.3 may be useful in determining which samples are amenable to compositing or forwarding to the analytical laboratory. Visual observations, site topography, and surface drainage patterns are also important in determining the appropriate leachate sampling locations.

3.2.2 Data Requirements

A detailed description of leachate remedial action alternatives can be found in Section 4.3. To evaluate the various remedial action alternatives, data gathered before or during characterization of leachate should include:

- A contour map to define surface water drainage pattern
- Soil characteristics including permeability, grain size distribution, and moisture content to determine the physical properties governing contaminant transport
- Climatological characteristics including temperature and precipitation to help determine approximate leachate volumes for the site
- Waste characteristics, including BOD, COD, pH, TDS, TSS, oil and grease, chlorides, nitrite, nitrate, ammonia, total phosphorus, sulfides, and metals, to determine a suitable leachate treatment system
- Depth to groundwater and groundwater flow direction and velocity to evaluate the feasibility of leachate or groundwater extraction and treatment

3.2.3 Leachate Summary

Leachate sampling at seeps and streams is recommended for both landfill types. Leachate can move laterally below ground toward a creek or stream, affecting the water quality. Sampling streams and leachate seeps can provide information on actual or potential water quality impacts. Installation of leachate wells at landfill Types I and II can provide information such as depth, thickness, and types of waste; leachate head levels and the composition of landfill leachate; and the elevation of the underlying natural soil layer. Table 3-3 summarizes the recommended leachate sampling locations.

Table 3-3 LEACHATE SAMPLING PROGRAM	
Location	Minimum Sampling Events
Collection drain	Two—collect one during dryer and one during wetter period of the year.
Surface locations—steam, seeps	Same as above.

Figure 3-2 presents a logic flow diagram for leachate sampling.

3.3 Landfill Contents/Hot Spots

Containment has generally been identified as the most practicable remedial technology for municipal landfills because the volume and heterogeneity of landfill contents often makes treatment impracticable. Characterization of municipal landfill contents therefore is generally not necessary because containment of the landfill contents do not require such information. More extensive characterization activities and development of remedial alternatives (such as thermal treatment or stabilization) may be appropriate for hot spots. The following subsections discuss site characterization strategies for landfill Types I and II for surficial soils, caps and liners, and landfill contents (including hot spots).

3.3.1 Landfill Contents/Hot Spot Investigations

Typically, investigations at municipal landfills are separated into four areas:

- Surficial soils
- Caps
- Liners
- Landfill contents

Surficial investigations are undertaken if there is either physical evidence or data that suggest the presence of substantially contaminated surficial soil in the general area of the landfill. Surficial sampling investigations should be limited if surface soils are planned to be

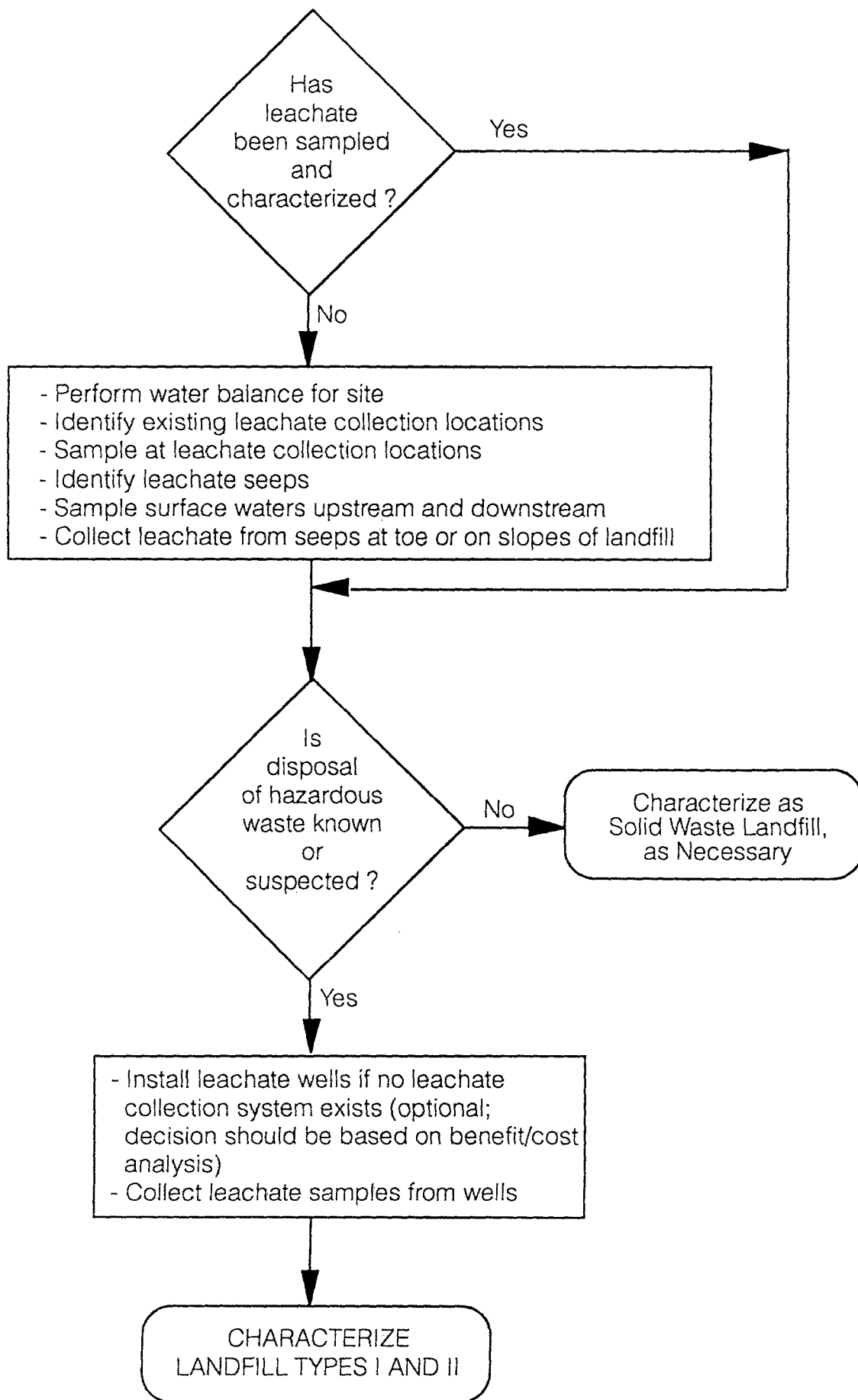

covered with a cap. Cap and liner investigations are undertaken when previous engineering studies or field observations indicate their presence at a site, while landfill content investigations are undertaken to characterize known or suspected hazardous waste disposal areas (potential hot spots). Small to moderate-sized landfills (e.g., less than 100,000 cubic yards) may also undergo subsurface investigations if the landfill poses either an existing or potential threat to human health or the environment and if it is appropriate to consider remediation of the entire contents of these landfills through excavation, treatment, or disposal.

It should be noted that investigations into landfill contents are rarely implemented at municipal landfills. This is due primarily to problems in excavating through refuse and the heterogeneous nature of the refuse, which makes characterization difficult. Sampling of landfill contents may, however, be useful for enforcement purposes (e.g., identifying PRPs). Drilling through the base of the landfill is not recommended due to the potential for migration of leachate to lower geologic strata. However, in general, drilling into refuse for installation of various extraction systems (for example, leachate and landfill gas) is commonly implemented (see Sections 4.2 and 4.4).

3.3.1.1 Objectives

The general purpose of characterizing soils and hot spots is to define the risks posed by these media/contaminants and select the appropriate remedial action alternatives for further evaluation. However, the specific objectives, and therefore, the sampling procedures, vary for each type of investigation. The objectives of each type of soils investigation are described below:

Topographic Surveys. The objectives of performing topographic surveys at municipal landfill sites are to:

- Establish a basis for determining the total and differential settlement of the existing cap
- Document erosion gullies and other relevant topographic features that might affect the remediation scheme or point to

anomalies that require further investigation

Surficial Soil Investigation. Surficial soil investigations are performed to:

- Determine the distribution and concentration of contamination in surficial soils
- Document erosion patterns
- Determine if the surficial soils, either in whole or just in hot spots, should be included in the source control actions for the landfill.

Investigations of surficial soils should be limited if there are plans to place a new cover system over the existing surficial soils. However, if surficial soils are significantly contaminated, particularly in hot spots, then separate source-control remediation of the contaminated soils may be considered; an investigation of contamination in the topsoil is appropriate, even if there are plans to place a final cover over most of the existing surficial soils.

Surficial soil investigations are normally focused on anomalies observed at the surface, such as:

- Leachate seeps
- Stains or other discoloration in the surficial soils
- Stressed vegetation

Analysis of surficial soil and sediment samples may confirm or complement data from analysis of surface waters. While the presence or absence of contamination of surficial soils may have no relationship to groundwater contamination, there may be contamination of surficial soils and no groundwater contamination, or vice versa.

Cap Investigation. A cap investigation is intended to determine if a new cover system would be required to reduce infiltration of water, to collect gas, to minimize erosion, or to meet ARARs. Another purpose is to define total and differential settlement that might

occur if a new cover system is placed on the landfill. If excessive settlement is predicted, the waste will probably require stabilization before final closure with an engineered cover system.

Existing caps may either be engineered or not. The degree of sophistication employed in the investigation of an existing cap will depend to a great extent on whether it is planned to use all or part of the existing cap in a new, engineered cover system. If none of the existing cap will be incorporated into the new cover system (e.g., if the existing cap will be buried beneath a new cover), detailed investigations of the existing cap are usually not necessary. If an existing cap was not properly designed and constructed, it will usually not be possible to incorporate the existing cap within the profile of a new, engineered cover system, although the existing cap may serve as foundation support for the new cover system. In many cases, a cursory investigation of the existing cap will verify that it was not constructed to engineering standards. In this situation, more detailed characterization of the existing cap is not necessary.

If it is suspected that an existing cap was engineered, and information on the design and construction of the cap is not available, then preliminary work should be performed to verify that the cap was properly designed and constructed. For example, suppose excavation of several test pits reveals that the cap consists of 12 inches of topsoil underlain by 2 feet of low-permeability soil that appears to have been compacted. This information suggests that the existing cap was engineered with the intention of including a layer of topsoil above a hydraulic barrier layer. If preliminary information indicates that the cap was engineered, and if it is desired to investigate the feasibility of incorporating all or part of the existing cap in the final cover system, then detailed characterization tests are needed to confirm the properties of the existing cap.

The objectives of a cap investigation are to:

- Determine the approximate thickness, composition, and horizontal extent of the existing cap (a greater level of detail is needed if the existing cap is engineered and will be incorporated in the final cover system)
- Determine if any hot spots of soil

contamination are present in the existing cap and characterize these hot spots to the extent necessary to determine whether the soils can be covered and left in the landfill or whether the hot spots need to be excavated and separately remediated for source control

- Document the integrity of the existing cap (e.g., determine if roots have penetrated through the cap) and determine the geotechnical and other relevant properties of the existing cap if the existing cap was engineered and will be an integral part of the final cover system
- Evaluate potential settlement (total and differential) of the landfill and the final cover system that will be placed on the landfill
- Evaluate the stability of any slopes and the capacity of the waste to support the final cover systems and any surficial loadings such as those from surface traffic or construction equipment

Liner Investigation. Liner investigations are rarely performed, even if there is evidence of a liner, since the liner could be punctured during the investigation and contribute to groundwater degradation. If a liner investigation is going to be performed, then the objectives may include:

- Confirming the existence of a liner
- Determining its permeability
- Evaluating, if possible, its susceptibility to chemical damage

A liner investigation could also be undertaken to determine the probability that contaminants will migrate to the groundwater.

Subsurface Soil and Landfill Contents Investigation. The purpose of subsurface sampling is to obtain a portion of soil (disturbed or undisturbed) or landfilled materials for chemical and geotechnical analysis. This can be done by drilling and taking samples of the subsurface soils and landfill contents or by excavating test

pits or trenches. As previously described, subsurface investigations may only be used at municipallandfills where documentation or physical evidence exists to indicate the presence of hot spots.

The objectives of subsurface testing, using test pits or trenches, are to:

- Evaluate the integrity of any buried drums
- Determine the degree of contamination of any unsaturated soil

Surface geophysical surveys are performed to identify areas of buried metal and other areas of concern. Based on the results, test pit locations can then be selected to investigate areas where drums or tanks are suspected. Magnetometer surveys (total field and vertical gradient), electromagnetic surveys, and soil gas surveys can be used to identify test pit sites. It should be noted, however, that landfills contain many products other than metal drums. Therefore, magnetometers and electromagnetic surveys are used only when there is evidence to suggest large, discrete areas of drum disposal. Trenching, test pitting, and boring installation are used to characterize hot spot areas. Test pits and trenches allow a larger, more representative area to be observed and permit selection of specific samples from relatively shallow subsurface materials (biased grab sampling). Test pits and trenches are typically dug to confirm the results of surface geophysical investigations, while borings are typically used to investigate deeper contamination. Also, soil gas surveys can be used to identify hot spots if the suspected contaminants include VOCs. The soil gas survey may be able to identify areas of higher VOC concentrations that can later be investigated with test pits or borings.

3.3.1.2 Procedures

Landfill Type I

A Type I municipal landfill is one in which co-disposal of hazardous and municipal waste occurred, but the location of highly toxic and/or highly mobile material, which presents a potential principal threat to human health or the environment (hot spots), is not known.

Topographic Surveys. Topographic data are often required to document erosional features, to identify topographic anomalies that might be related to deteriorated drums or other hot spots, and to provide a basis for evaluating the potential total and differential settlement resulting, from decomposition of waste or compression of waste from the weight of the final cover system. The survey should be designed to define areas with a differential settlement as small as 6 inches over horizontal distances of 10 feet. To document settlement over time, a series of settlement markers should be established on a grid pattern of approximately 100 feet (more in areas with known settlement problems).

Surficial Soils. Surficial soils are investigated to determine the distribution and concentration of contamination, to document erosion patterns, and to determine if surficial soils should be included in source control actions. Before the sampling is initiated, the soils exposed at the surface should be examined visually for evidence of staining; field personnel should also look for signs of vegetation stress. Geophysical techniques such as electromagnetics or ground-probing radar may be helpful in identifying anomalies, hot spots, or other zones of surficial soil that warrant investigation. If it is anticipated that an engineered cover system will be constructed over the area of concern, sampling of surficial soils may not be necessary or sampling efforts may be limited. If there is an engineered cap on the landfill, surficial soil samples for analysis of contaminant concentration may not be needed unless surficial soil is likely to remain as is, and the history of the soil used for the cap is unknown.

To sample surficial soils, a grid often is superimposed on each area suspected of contamination, e.g., stained areas or vegetation-stressed areas. Soil samples can be collected at alternate nodes on the grid. The node samples can be composited to reduce the number of analyses. The analyses from at least two background samples should be available for comparison. Background samples should be obtained from areas with a similar soil composition on the site, but outside the influence of the site. Previous activities at any offsite locations should be considered before collecting back-

ground samples, since these offsite activities could introduce contamination.

The depths of the surficial soil sample and the analytical parameters vary from site to site but, in general, should be specified as follows:

- Samples for priority pollutant metals and cyanide analyses should be collected from the 0- to 6-inch depth to characterize direct exposure risks (i.e., contact and ingestion).
- Samples for VOC analyses should be collected from the 18- to 24-inch depth because these compounds tend to evaporate from the soil at shallower depths.

Other sampling depths may be appropriate based on site-specific circumstances (e.g., depth to groundwater, soil structure). While samples from different nodes may be composited horizontally, vertical compositing is not recommended, except over short intervals, because compositing will obscure analytical results. Additionally, compositing samples for VOC analysis is not recommended because of losses during mixing of samples. Additional analyses can be performed, depending on the results of the site history and previous waste characterization studies. Additional analytical parameters could include RCRA hazardous waste characteristics, total BTU content, and bulk weight of the material.

The frequency of surficial soil sampling depends on the characteristics of the soil and waste, and requires professional judgment. For example, contaminant migration from uniformly deposited waste in a relatively uniform soil will be more predictable than migration from random placement of wastes in a heterogeneous environment such as a landfill. Sampling will, therefore, be required at a higher frequency near the landfill area, since contaminants can be expected to migrate irregularly.

Surficial soil samples can be collected using stainless steel trowels or shovels, hand augers, or soil sampling tubes. Samples containing volatile compounds must be sealed to prevent losses. Special techniques may be required to preserve soil samples so that levels of contami-

nation do not change between sampling and analysis.

Cap Investigation. The cap investigation must be carefully planned to maximize the value of data collected and to ensure that unnecessary data are not collected. First, it must be determined whether the existing cap is likely to have been engineered. In most cases, the existing cap will not have been engineered, and since it is recommended that these type cover systems are not used as part of a new engineered cover system (except as a foundation) detailed assessment of the geotechnical properties of the cap materials is usually not necessary. However, basic information concerning the approximate thickness and lateral extent of the existing cap, composition of the cap, and characteristics of the soils that make up the cap will need to be developed. There are many techniques that may be used in determining the thickness and lateral extent of the cap, including surface geophysical techniques such as ground-penetrating radar. However, drilling of holes or excavation of test pits will generally be needed either alone or as a means to calibrate surface geophysical techniques. Sampling at a frequency of approximately one exploratory boring or trench per acre is suggested. Samples should be analyzed to determine the liquid and plastic limits of the soils, percentage of fines, percentage of gravel, moisture content, shear strength, and any other relevant parameters.

For more detailed investigations, an appropriately sized grid can be superimposed on several areas of the existing cap. Samples can be collected either at alternate nodes on the grid or randomly. Areas selected for sampling should include both representative locations and those areas where erosion, cracking, or fracturing has occurred.

Shallow test pits can be dug to expose a cross section of the cap. Test pits can be dug by hand or with a backhoe. Test pits are usually excavated no more than 1 foot below the thickness of the cap. Exploratory borings, drilled with a hand auger or truck-mounted equipment, can also yield information on the materials that make up the existing cap. Sampling tubes can be pushed or driven into the cap materials if the characteristics of the in situ material need

to be identified. Otherwise, disturbed samples of materials generally are collected for later use in the laboratory. Procedures described in ASTM Standard D420, *Standard Guide for Investigating and Sampling Soil and Rock*, should be followed.

If undisturbed samples are to be obtained, a thin-walled sampling tube (often called “Shelby tube”) should be used. Shelby tubes are pushed into the cap using a drill rig, hydraulic ram, or other device that provides a straight, steady push. It is not recommended that the sampling tube be pushed directly with a backhoe because that usually tilts the tube. Also, the sampling tube should never be driven into the soil if an undisturbed sample is sought. The sampling tube usually is not pushed more than about 18 inches into the soil; a push of 6 inches or less is recommended for very stiff or hard, cohesive soils. Once a sample has been obtained, it is classified in the field, extruded from the sampling tube, and sealed in a sample-holding device or sealed directly in the tube. Samples then are placed in specially designed boxes that hold the samples in position and prevent their disturbance during transport back to the laboratory. Collection of undisturbed samples should be in accordance with ASTM Standard D1587, *Standard Practice for Thin-Walled Tube Sampling of Soils*. Transport and storage of samples should be in accord with ASTM Standard D4220, *Standard Practices for Preserving and Transporting Soil Samples*.

Undisturbed samples are tested routinely to determine the moisture content and density of the soil and are subjected to relevant tests to define the soil property of interest, e.g., shear strength. Undisturbed soil samples are sometimes tested for more routine properties, such as liquid and plastic limit, to develop a basis for comparing the results of various laboratory tests.

Tests to determine compaction characteristics are usually performed on large, bulk samples of the materials obtained from soil borings or test pits. However, unless the existing materials in the cap will be excavated and recompacted, there is usually no need for compaction tests other than to verify that the existing materials are well or poorly compacted. (In most cases, the existing cover

materials are assumed to be poorly compacted.)

Sometimes the permeability (to air or water) of existing cap materials will require evaluation. If the existing cap, or a layer within the existing cap, is expected to have a low permeability, a combination of laboratory permeability tests on undisturbed samples and field (in situ) permeability tests is recommended. However, field tests are time consuming and difficult; they are usually recommended only when the use of the existing cap materials for a low-permeability barrier in the final cover system is being considered. Laboratory permeability tests usually are performed at a frequency of 1 per acre per lift on modern, engineered, low-permeability barriers of compacted soil. A similar frequency would be appropriate for evaluation of a pre-existing barrier that is thought to have been engineered or otherwise constructed to achieve a low permeability. The recommended method for laboratory permeability testing is ASTM D5084, *Hydraulic Conductivity of Saturated Porous Materials Using a Flexible Wall Permeameter*.

In some circumstances, the existing cap may have a high permeability, and the material could be used as a gas collection layer within the final cover system. Accurate measurement of extremely high gas permeability is difficult; accepted methods of in situ testing do not exist. The permeability to air is probably best evaluated on the basis of grain size and permeability to water, as measured in the laboratory. With an existing material that is suspected of having a high permeability, the main issue to be investigated is whether the material has sufficiently high permeability over the full areal extent of the site. Thus, testing of many samples (at least three tests per acre) to establish consistency of high permeability would be appropriate.

After the initial stage of geotechnical investigation and sampling is completed, the results are evaluated to determine whether more field work is needed. Additional tests may be necessary to evaluate various issues. For example, it may be necessary to construct test patches of the proposed cover material over the landfill to determine the feasibility of constructing and

compacting materials for the final cover system on weak, compressible waste materials.

Waste Investigation. The physical and biological properties of the landfill contents have an influence on the feasibility of placing a final cover on a site. Some wastes are so compressible or biologically unstable that technical problems can arise in constructing and maintaining a final, engineered cover because of excessive settlement. In such cases, it may be necessary to physically or biologically stabilize the waste prior to placement of a final cover. The need to stabilize the waste prior to construction of a final cover may be a critical issue in the feasibility study of closure of the site.

The depth of waste must be accurately defined so that settlement patterns can be calculated. Surface geophysical techniques, such as seismic refraction, can be useful in defining the depth of waste in some circumstances. Drilling soil borings is the most reliable way to determine the depth of the waste; however, in some cases, this may pose unacceptable health and safety risks. Particular attention should be given to evaluating the variability of thickness of the waste because a variable thickness can cause significant and harmful differential settlement of the final cover.

It may be advantageous to initiate a program to measure settlement of the landfill. This would include the installation of one or more benchmarks outside the fill area and periodic surveying of settlement markers placed on the surface of the existing cap. The measurement of settlement may need to extend through the RI/FS and into the remedial design in order to monitor for a sufficient time. Differential settlement is often more critical to the performance of a final cover system than is total settlement. The magnitude of differential settlement, expressed as the amount of settlement over a specified horizontal distance, that exists in a cap can be a useful indicator of future problems with differential settlement. Sometimes more extensive testing may be needed to quantify differential settlement and to define the need for stabilizing the underlying waste. Examples of these types of studies include:

- Passage of a heavy, vibratory compactor

over the surface of the site and measurement of the resulting settlement

- Prototype deep, dynamic compaction (which involves dropping a large weight on the surface to compact underlying materials)
- Construction of a test fill on the existing cap

The degree of decomposition of the landfill is often relevant to issues such as potential for future settlement and generation of gas. Knowledge of the amount of organic materials, volatile solids, ash content, and moisture content usually helps in understanding the condition and stability of the buried waste.

Geotechnical tests such as shear strength and consolidation tests often are impractical for solid wastes because large fragments of solid waste cannot be small laboratory test specimens. However, if the waste is homogeneous and free of large fragments, such tests are practical and should be performed to characterize the strength and compressibility of the waste.

When laboratory testing of samples from municipal landfills is impractical (as is usually the case), the engineering team generally will be forced to rely upon published data on the geotechnical properties of waste. These properties are sensitive to the bulk density and moisture content of the waste. An attempt to quantify bulk density (even if approximate) and moisture content of the waste may yield valuable data for purposes of estimating other characteristics of the waste material.

The potential for the waste to produce gases from volatilization or decomposition should be evaluated. Analysis of gas from venting wells usually is definitive.

Liner Investigations. Liner investigations should be performed only if previous engineering studies indicate the presence of a liner and the liner is easily accessible. In general, soil borings should not be taken through any liner because contamination may be spread by puncturing the confining layers. However, in prac-

tice, it is impossible to confirm that a liner exists without drilling to the liner and sampling it; this will usually require some penetrations. The penetrations must be carefully sealed using techniques similar to those for sealing monitoring wells.

If the liner extends to the sides of the municipal landfill, then samples may be collected at the edge of the liner. For low-permeability soil liners, tests to define permeability, as described for caps, should be performed. For geomembranes, the liner samples should be collected where leachate seeps are evident, if possible, and examined for deterioration.

Favorable results (e.g., low permeability), from the tests do not necessarily mean that the unexamined portion of the liner is preventing groundwater contamination. Rips, tears, or uneven distribution of liner materials could exist. Hydrogeological studies also should provide more information on the condition of any liner, although these studies may provide inconclusive data.

Landfill Type II

Landfill contents are generally only sampled where hot spots are suspected from either physical evidence or record searches or when the landfill is smaller than 100,000 cubic yards and it has been determined that (1) the landfill poses an actual or potential risk to human health or the environment, and (2) it is practicable to consider excavation and/or treatment of the contents. Landfill sampling is not normally performed under other circumstances, since it can be assumed that landfill contents are heterogeneous. The horizontal extent of hot spots should be delineated using magnetometer, electromagnetic (terrain conductivity), or soil gas surveys. Electromagnetic surveys are used principally to detect drum clusters buried near the surface (e.g., approximately one half times the coil spacing); magnetometer surveys are used to detect drums buried as deep as 15 feet beneath the surface; and soil gas surveys are used to detect leaking drums containing VOCs. Confirmation and contaminant quantification in hot spot areas are done by excavating test pits or drilling soil borings.

These survey methods develop numerous data points. Reduction, processing, and presentation are major concerns in proper interpretation and analyses of the data. If available, data taken in the field should be electronically recorded and downloaded to a computer system for processing. Additional information on the use of these methods may be found in *Quantitative Magnetic Analysis of Landfills* (Bevan, 1983) and *Magnetic Survey Methods Used in the Initial Assessment of a Waste Disposal Site* (Fowler, date unknown).

Magnetometer Survey. A magnetometer measures the total magnetic field of the earth and its localized perturbations. A metal mass such as steel drums or other ferrous materials distorts this magnetic field and is indicated on the readout. Magnetometer surveys are used at municipal landfill sites to determine the extent, location, and relative magnitude of drum disposal areas and may provide useful information in determining the extent of the landfill boundary. A magnetometer survey may be conducted rapidly with minimal labor and field time.

Before conducting a magnetometer survey, an appropriate-sized grid is laid out over the portion of the landfill suspected to contain the buried drums. The lines should be generally oriented in a north-south fashion, and should be plotted and labeled on a site topographic map. Data intervals (points on the line) should be greater than 10 feet, and space between traverse lines should be at least 25 feet. In situations where the size and approximate mass of a suspected object is known, the characteristics of the suspected object would dictate the line intervals and points. A fixed point should be established where base data can be collected at various times during the day. This information can be used for correction purposes.

During the magnetometer survey, the field team should note any potential interference. These may include any steel on the surface, construction debris that may contain steel rebar, fences, power lines, and other buildings. Some of the local interferences with the magnetometer sensor can be minimized by increasing the distance between the ground and the sensor.

Total field and vertical gradient measurements are collected using the magnetometer. Vertical gradient data have higher resolution than the total field data and minimize potential noise problems (e.g., interference from miscellaneous ferrous materials such as wire). The total field and vertical gradient data are collected simultaneously. At the completion of the magnetometer survey, data can be corrected for the effects of the diurnal changes in the local magnetic field. Once this is done, a magnetic contour map is prepared to interpret magnetic anomalies.

Electromagnetic (Terrain Conductivity) Survey. An electromagnetic survey measures the conductivity variations between landfill soils and suspected drum disposal areas. These surveys indicate where buried drums may be located. Depth estimates can be generalized by incorporating magnetometer components and both the horizontal and vertical components of the electromagnetic survey data. Magnetometer data is dependent on the amount of ferrous mass and the depth of which it is buried. A large mass that is buried very deep will look the same as a small mass buried near the surface. By combining the vertical and horizontal electromagnetic survey data, one can determine how deeply a particular mass is buried.

The objective of an electromagnetic survey is to locate buried metallic and/or conductive masses such as discrete drum disposal areas. However, conductivity variations in soils or landfill materials often limit the survey's ability to distinguish the disposal areas. An electromagnetic survey can be used for rapid data collection with minimal site preparation.

Before conducting an electromagnetic survey, an appropriate-sized grid is laid out over the portion of the landfill suspected to contain the subsurface materials. Data are often collected at 3-meter coil separations but can be extended to 10, 20, and 40-meter spacings, depending on the depth of investigation required. If soil conditions permit (i.e., thin or non-existent clay layers), ground penetrating radar can also be used. The different coil separations and orientations (vertical and horizontal) help identify whether conductivity variations are caused by shallow or deep sources. The data are

plotted and contoured to describe the source disposal area.

Soil Gas Survey. If a magnetometer or electromagnetic survey does not accurately define the boundaries of subsurface drum disposal areas *and* the contaminants of concern are VOCs, soil gas surveys can be conducted. Also, if the hot spot is an area of open dumping of hazardous substances, including VOCs, a soil gas survey may be useful in delineating the area extent. As part of the soil gas survey, ground probes are driven to planned depths, and a vacuum pump is used to draw the samples from the probe. Soil gas samples are collected in Tedlar bags or stainless steel bombs, or are adsorbed onto carbon or analyzed in the field with an OVA. Initially, vertical profiles of organic gases in the soil pore spaces are measured and plotted at several locations. Based on these vertical profiles and the particular organic gases present, the sampling depth for more soil gas samples is selected.

Once a constant sampling depth is established, soil gas samples are collected on an appropriate-sized grid laid out over the suspected disposal area. Once the location is better delineated, additional sampling on a smaller grid may be conducted to refine the limits of the area. If results from the initial vertical profiles do not provide sufficient data to find a solvent plume, the soil gas survey may be discontinued. The sampling depth may be limited by the presence of buried drums, and extreme care should be exercised when driving probes into landfills.

Analyses of the samples can delineate the boundaries of contaminated subsurface areas. These surveys can also be used to minimize the number of test pits, geotechnical borings or monitoring wells that must be drilled or installed. Soil gas surveys can save the time and expense included in drilling additional geotechnical borings and monitoring wells; however, they are more time-consuming and expensive than magnetometer and electromagnetic surveys.

Test Pits or Trenches. Depending on the results of the geophysical surveys and soil gas surveys, test pits or trenches may be excavated.

OSHA requires that some type of investigative method such as test pitting be used prior to any excavation. Test pits or trenches are typically excavated by backhoes due to the anticipated hazardous nature of any subsurface materials. The size of the excavation depends primarily on the following:

- Approximate area of the buried materials
- Space required for efficient excavation
- Economics and efficiency of available equipment

Test pits normally have a cross section that is 4 to 10 feet square; test trenches are usually 3 to 6 feet wide and may extend for any length to reveal conditions along a specific line. Further information on test pits is available in EPA's *A Compendium of Superfund Field Operations Methods* (EPA, 1987h).

Trenches or pits should not be excavated too closely together. Sufficient space should be maintained between excavations to put soils that will be stockpiled for cover, and to allow access and free movements by haul vehicles and operating equipment. Excavated soil should be stockpiled to one side in one location. If possible, it should be downwind of the excavation and away from the edge of the pit to reduce pressure on the walls. Soils should be placed on a sheet of heavy plastic to prevent additional contamination of surface soils.

If the excavation uncovers drums, they should be carefully examined for identifying markings. Information stenciled on drums can sometimes be used to identify PRPs. Any labels on the outside of the drums should also be used to specify additional analytical parameters for soil testing. Samples are selected by depth, visual observations (e.g., soil staining), the concentration or types of VOCs detected during the screening process, and stratigraphic relationships.

The field supervisor selects the depth intervals after consultation with the project hydrogeologist and chemist. At least one sample is collected from each wall and the bottom of the excavation for field

screening. If visual observations and the field screening procedures indicate that the samples are similar, they may be composited before laboratory analysis. If visual observations, field screening, or stratigraphic relationships indicate that the samples are different, then they should be analyzed separately by the laboratory. Samples of possible waste materials (e.g., leaks from buried drums or tanks) should not be composited.

Test pits excavated into fill are generally more unstable than pits dug into natural in-place soils. Any required samples should be gathered without entering the test pit or trench. Samples of leachate, groundwater, and sidewall soils can be taken with telescoping poles, etc., or if necessary, from the bucket of the backhoe. If intact or crushed drums are encountered, they should not be removed. Drummed materials should not be tested unless the drums are degraded and leaking, as evidenced by the presence of liquids in the test pits around them.

Dewatering may be required to assure the stability of the side walls. This is an important consideration for excavations in landfill material. Liquids removed as a result of dewatering operations must be handled as potentially contaminated materials. The water from any excavated saturated soils and erosion or sedimentation of these soils should be controlled. A temporary detention basin and a drainage system should be considered, if necessary, to prevent contaminated wastes from spreading.

Following completion of sampling and test pit logging, test pits are backfilled to grade. If excess material shows evidence of gross organic contamination or photoionization detector (PID) readings above background, it should be drummed. Otherwise, the excavated materials should be evenly spread over the test pit area and covered with uncontaminated soil.

The analytical results are compared with the groundwater plume data to identify groundwater contaminant source areas. This information is used to identify the potential for future contaminant releases to the groundwater; to evaluate containment, treatment, and disposal alternatives for the hot spots; and to identify PRPs.

Soil Borings. In some cases it may be appropriate to drill soil borings within the landfill contents to characterize known hot spots. The number and depth of borings should be based on site specific conditions such as the suspected size and depth of the hot spot, and potential variability in contaminant levels within the hot spot. Prior to drilling soil borings into a hot spot, a geophysical survey should be completed as well as a review of any existing information (such as disposal records) on the nature of contamination in the hot spot.

Care must be exercised when sampling landfill contents because drilling through the landfill could compromise the integrity of any liners (particularly synthetic membrane liners), or penetrate a gas pocket causing an explosion hazard or release of VOCs. Sampling landfill contents can also be difficult, as garbage bags, baling wire, etc., cling to the augers. Sampling should be extended to the bottom of the landfill only in situations where the depth of the landfill is known and where it is known that there is no liner. Sampling should not penetrate the base of the landfill.

Landfill content samples are usually taken at intervals approved by the field engineer or geologist. Samples are typically taken at each change in material type and are based on sampling using field monitoring instruments. Where sampling is difficult or a larger volume of material is needed, a larger-diameter split-spoon sampler (3-inch), a Shelby tube, a pitcher-type sampler, or a piston-type sampler might be required.

3.3.1.3 Guidelines

Determining the extent of soil contamination can be very time consuming and costly. It is important to keep the principal focus for conducting any soil sampling in the proper perspective, that is, defining grossly contaminated soil that will be addressed by remedial action alternatives developed for the landfill contents or hot spots. Characterization of landfill contents is not necessary when capping is the only practicable remedial action alternative.

A combination of field instruments and appropriate laboratory samples can be used to preliminarily determine the type and extent of contamination

while minimizing cost and time. However, field analytical techniques have certain limitations:

- OVA or PID. If VOCs are in the soil, the use of an organic vapor analyzer (OVA) or photoionization detector (PID) may indicate the presence of VOCs. However, the head space reading from a sample will depend on time delay after sampling, temperature, seal of lid on sample container, and wind. The results of the head space reading indicate VOC contamination, but usually do not produce quantitative results. It should be noted, when selecting an instrument, that an OVA will detect methane where a PID will not.
- Mobile Laboratory Gas Chromatograph. The use of a field gas chromatograph requires the availability of a power supply or battery packs with a clean area. This allows the analysis of samples for many contaminants depending on the column used, but does not provide total contaminant levels.
- Metals Analyses. Field instruments for metals analyses are limited to detection of certain indicator compounds, such as copper, mercury, and chromium, but do not detect levels below 10 ppm.
- Mobile Laboratory PCB Analysis, Polychlorinated byphenyls (PCBs) in the soils can be detected in the field using the proper extraction solvent and gas chromatograph (GC). These surveys can provide immediate information on the lateral extent of soil contamination. However, this usually requires the use of a field lab set up at the site and generally is a large expense for timely turnaround (PCBs can be analyzed on a field portable GC, with the right column).
- Acids or Bases. Soil pH can be measured by mixing standard volumes of soil and deionized water and measuring the resulting pH of the slurry with a pH meter.

3.3.2 Data Requirements

To evaluate the various remedial action alternatives for landfill contents and hot spots, data gathered before or during the site characterization of landfill contents/hot spots should include:

- 1-foot contour maps on an appropriate scale (e.g., 1 inch equals 50 feet) so that slope length and gradients can be assessed for capping alternatives
- Soil characteristics, including permeability, grain size, Atterberg limits, and erosion rates, for grading, capping, and thermal treatment alternatives
- Waste characteristics of hot spot areas including TAL metals, TCL organics, RCRA waste characteristics (e.g., ignitability, corrosivity, reactivity), total BTU content, bulk weight of the material, and results of any pilot testing (if necessary) for thermal treatment alternatives
- Climatic conditions including the 25-year, 24-hour storm, frost depth, and surface water runoff velocity for cap design
- Existing cap characteristics
- Geologic characteristics and groundwater depth for capping and hot spot excavation alternatives
- Future uses of the site

3.3.3 Landfill Contents/Hot Spots Summary

Table 3-4 summarizes the sampling requirements for soils and landfill contents. Figure 3-3 shows a logic diagram for the decisions necessary to characterize soils and landfill contents by landfill type. For Landfill Type I, the following site characterization is necessary:

- Soils at leachate seeps
- Areas with stressed vegetation
- Stained soils
- Existing caps and liners, if accessible

Geophysical surveys and test pits are not required.

For Landfill Type II, the following site characterization steps are necessary:

- Soils at leachate seeps
- Areas with stressed vegetation
- Stained soils
- Existing caps and liners, if accessible
- Hot spot areas involving geophysical and soil gas surveys, test pits and borings

3.4 Landfill Gas

Several gases are typically generated by decomposition of organic materials in a landfill. The composition, quantity, and generation rates of the gases depend on such factors as refuse quantity and composition, refuse placement characteristics, landfill depth, refuse moisture content, and amount of oxygen present. The principal gases generated are carbon dioxide, methane, nitrogen, and occasionally, hydrogen sulfide. Vinyl chloride, toluene, benzene, hydrogen cyanide, and other toxic contaminants may also be present.

During a landfill's early stages the refuse undergoes aerobic decomposition, and the principal gas generated is carbon dioxide. Once all the free oxygen is depleted, the refuse decomposition becomes anaerobic, and the principal gases become carbon dioxide and methane. Migration of landfill gas can pose onsite and offsite fire and explosion hazards. In addition, landfill gas can be an inhalation hazard and can become soluble in groundwater.

3.4.1 Landfill Gas Investigations

3.4.1.1 Objectives

The goal of landfill gas characterization is to identify areas in the landfill containing high concentrations of explosive or toxic landfill gas to:

- Perform an assessment of human health risks due to air toxics and explosive hazards

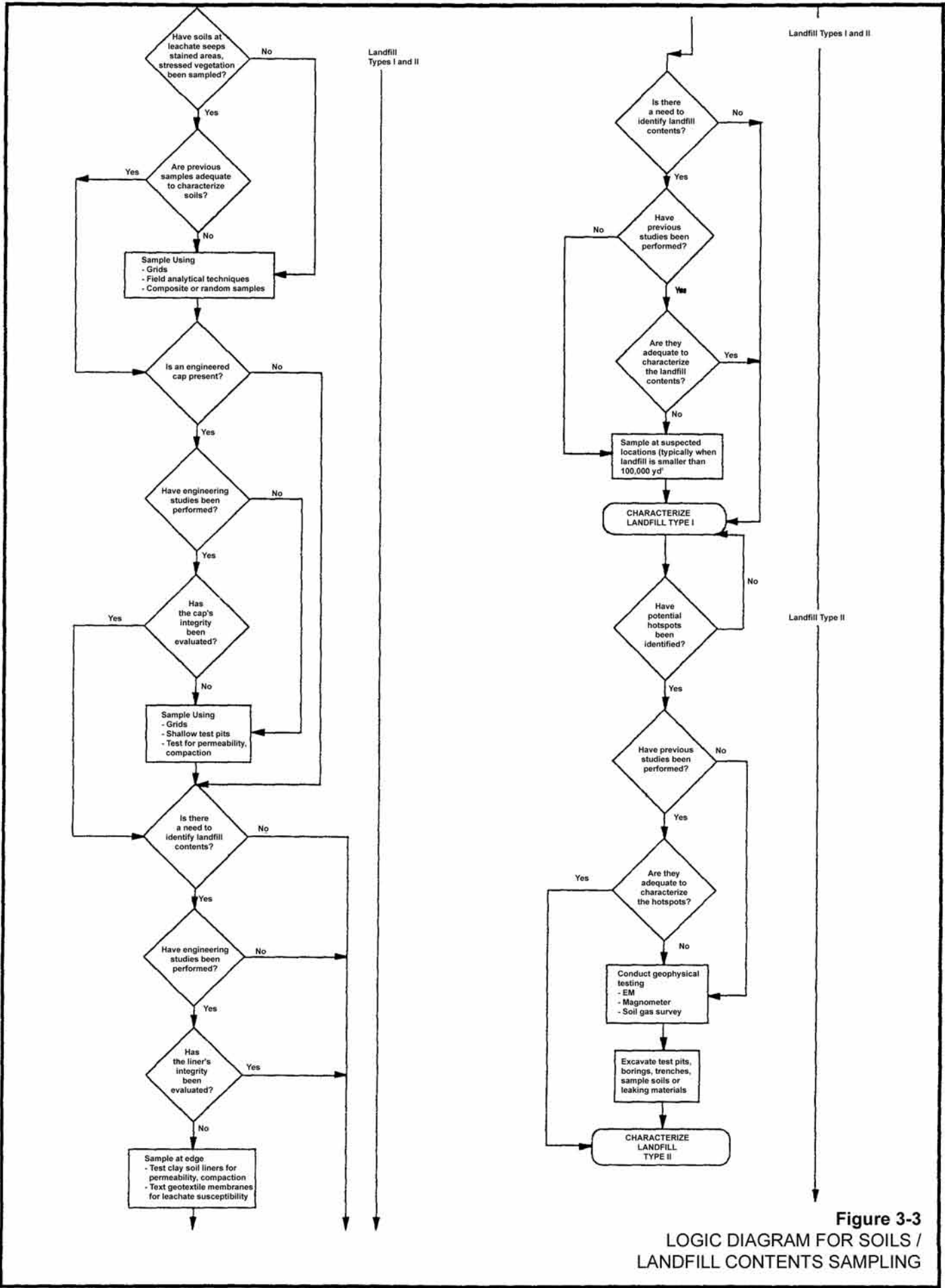

Figure 3-3
 LOGIC DIAGRAM FOR SOILS /
 LANDFILL CONTENTS SAMPLING

**Table 3-4
SUMMARY OF SAMPLING REQUIREMENTS FOR SOIL AND LANDFILL CONTENTS**

Medium To Be Investigated	Sample Location	Considerations
Surficial soil--stained or stressed areas, leachate seeps	Horizontal composites from alternate grid nodes or random locations on the grid.	Metals and cyanide at 0-6 inches. Volatile organics at 18-24 inches.
Existing Cap	Representative random areas <i>and</i> areas where erosion, cracking, fracturing occurs.	Permeability, compaction tests. Test pits to determine cap depth.
Existing liners, if accessible	Accessible edges of liner.	Clay and soil--permeability, compaction. Geotextile--susceptibility to chemical damage.
Landfill contents	Random areas in landfill of less than 100,000 yds ³ .*	Stratigraphic changes, analyses for contaminants indicated by record search.
Hot spots	Grids for surface geophysical methods, one sample from each wall and bottom of test pit--composite or discrete.	Use surface geophysical methods first, excavate test pits.

*Sampling of landfills of small to moderate volume is dependent on (1) whether the landfill poses a potential principal threat to human health or environment, and (2) whether it is practicable to consider excavation, disposal, or treatment of the landfill contents.

- Evaluate the feasibility of gas collection and treatment
- Evaluate other remedial actions

The landfill gas investigation can be focused to collect data specific to the remedial alternatives available for landfill gas. These remedial alternatives typically include active or passive landfill gas collection systems which are described in Section 4.4. The following subsections discuss the objectives, the procedures, and general guidelines for site characterization of landfill gas.

3.4.1.2 Procedures

Various landfill gas collection methods can be used, depending on the type of landfill, and are described below.

Landfill Type I Methane gas as well as other potential toxic gases are of concern at this type of landfill where disposal of hazardous wastes with municipal wastes has occurred, but there are no known or suspected hot spots. Grid sampling for landfill gas at random areas is the recommended approach for this type of landfill. Landfill gas samples should be collected from areas of the landfill where methane production is suspected, such as for sites where a passive venting system already exists. Field screening may be used to identify these areas if they are not already known. However, note that any field screening instrument employing a PID will not respond to methane due to methane's high ionization potential. Flame ionization detectors such as the OVA can be used to screen for methane. Methane-specific Draeger tubes can also provide a qualitative measure of the presence of methane in landfill gas. Analysis

should include VOC analysis to identify the presence of toxic organics. If specific contaminants of concern have been identified, contaminant-specific Draeger tubes can be used. If specific contaminants have not been identified, GC analysis for target compound list (TCL) VOCs should be performed.

Soil gas probes are commonly used to collect landfill gas samples due to the relative ease of sample collection using this process. An appropriately sized grid can be superimposed on a target area, and the nodes sampled (grid sampling). A grid size of 100 feet by 100 feet is often used. Grids can be tightened to address smaller target areas of known methane production. The use of soil gas probes can also be helpful in evaluating potential offsite migration.

Samples are analyzed using a gas chromatograph. Sampling equipment should be decontaminated between sampling points to prevent any cross-contamination. Using the OVA with a charcoal pre-filter can help improve the qualitative measure of methane concentration in landfill gas. The charcoal filter adsorbs most of the non-methane gases, which results in an OVA reading closer to the actual methane concentration in the gas sample.

Samples can be collected from existing gas vents or from test pits. A typical test pit can be 1 cubic foot in size (e.g., approx. 1 foot deep). It is covered with a board with a small opening on top. Gas samples can be pumped using a small electric or battery operated pump from this opening into a Tedlar bag (or stainless steel canister). The Tedlar bag samples can be analyzed using the OVA or by onsite analysis using a mobile GC, and is typically used for fast-turn-around results. Samples can be collected using existing extraction wells following this same procedure. Stainless steel canisters are state-of-the-art air/gas collection devices that can be shipped for offsite analysis more readily than the other collection devices, but are expensive and require elaborate decontamination procedures before they can be reused. Special care should also be taken with the field and trip blanks for air samples due to possible cross-contamination or laboratory problems.

Landfill Type II. Like landfill Type I, methane gas as well as other potential toxic gases are of concern at this type of landfill where disposal of hazardous wastes with the municipal wastes occurred, and there are known or suspected hot spots. Grid sampling of random areas for methane sampling is recommended if no known methane production areas have been identified. Known hot spots can be sampled for toxic contaminants (such as VOCs suspected to be present) on a tighter grid, based on the size of the hot spot area. Sample collection procedures described for Landfill Type I can be employed; VOC analysis should definitely be performed to identify the presence of toxic organics. If specific contaminants of concern have been identified, contaminant-specific Draeger tubes can be used; followup of laboratory analysis of these specific contaminants should be conducted. If specific contaminants have not been identified, GC analysis for TCL VOCs should be performed.

Further information on landfill gas sampling methods is available in EPAs *A Compendium of Superfund Field Operations Methods* (EPA, 1987h).

3.4.1.3 Guidelines

A gas monitoring program is difficult to establish because of the difficulty in predicting where the gas will migrate. If the cover material for a landfill has a high clay content, is well compacted, or is wet or frozen, it is not too likely that the gas will diffuse uniformly up through the cover. Plots of isoconcentration lines of gas concentrations determined from field monitoring may assist in determining migration patterns. Monitoring for landfill gas around the perimeter of the landfill may also be useful in determining lateral migration patterns.

A landfill gas monitoring program may also include some sampling in residential areas. This may include sampling for landfill gas in nearby basements of residential or commercial buildings.

3.4.2 Data Requirements

A detailed description of landfill gas remedial action alternatives can be found in Section 4.4.

To evaluate the various remedial action alternatives, data gathered before or during the site characterization of landfill gas should include:

- Contour maps to determine possible migration patterns
- Geologic, hydrogeologic, and soil characteristics including permeability, moisture content, geologic strata, pH, and depth to bedrock and groundwater to determine potential gas migration patterns
- Landfill gas characteristics including composition, moisture content, quantity, and heat and methane content to determine treatment alternatives
- Types of microorganisms present in waste to determine biodegradation stages (for estimating gas production)

3.4.3 Landfill Gas Summary

Table 3-5 summarizes the recommended sampling locations for landfill gas. Figure 3-4 illustrates the decision process required to determine the appropriate sampling approach to be implemented.

For Landfill Type I, soil gas probes and grids over a 100- by 100-foot area with sampling for methane and VOCs is recommended. For Landfill Type II, the same sampling locations are recommended, with

the exception that a tighter grid (based on the size of the hot spot) is used in hot spot areas, and that sampling for methane, VOCs, and specific contaminants associated with the hot spots is recommended.

3.5 Wetlands and Sensitive Environments

Many municipal landfills have been built on or next to natural wetlands or other sensitive environments. Sensitive environments next to municipal landfills may be contaminated by inflows of leachate through the surface water or groundwater pathways. In addition, contaminated sediments in wetlands may adsorb heavy metals or complex organics in leachate and source material from municipal landfills. The following subsections broadly discuss the objectives, procedures, and guidelines for characterizing nearby wetlands and sensitive environments.

3.5.1 Wetlands and Sensitive Environment Evaluation

Data gathered before or during the environmental evaluation will be used to characterize the contamination and its extent (e.g., sediment volume) and to assess the impact of contamination on indigenous biota. Wetlands should be delineated in accordance with the *Federal Manual for Identifying and Delineating Jurisdictional Wetlands* (U.S. Fish and Wildlife Service, et al., 1989).

Landfill Type	Sampling Locations	Analysis
I	Soil gas probes at node of 100- by 100-foot grid over random areas.	Methane and VOCs.
II	Soil gas probes at nodes of 100- by 100-foot grid over random areas and tighter grid over hot spots (based on size of hot spot area).	Methane, VOCs, and specific contaminants.

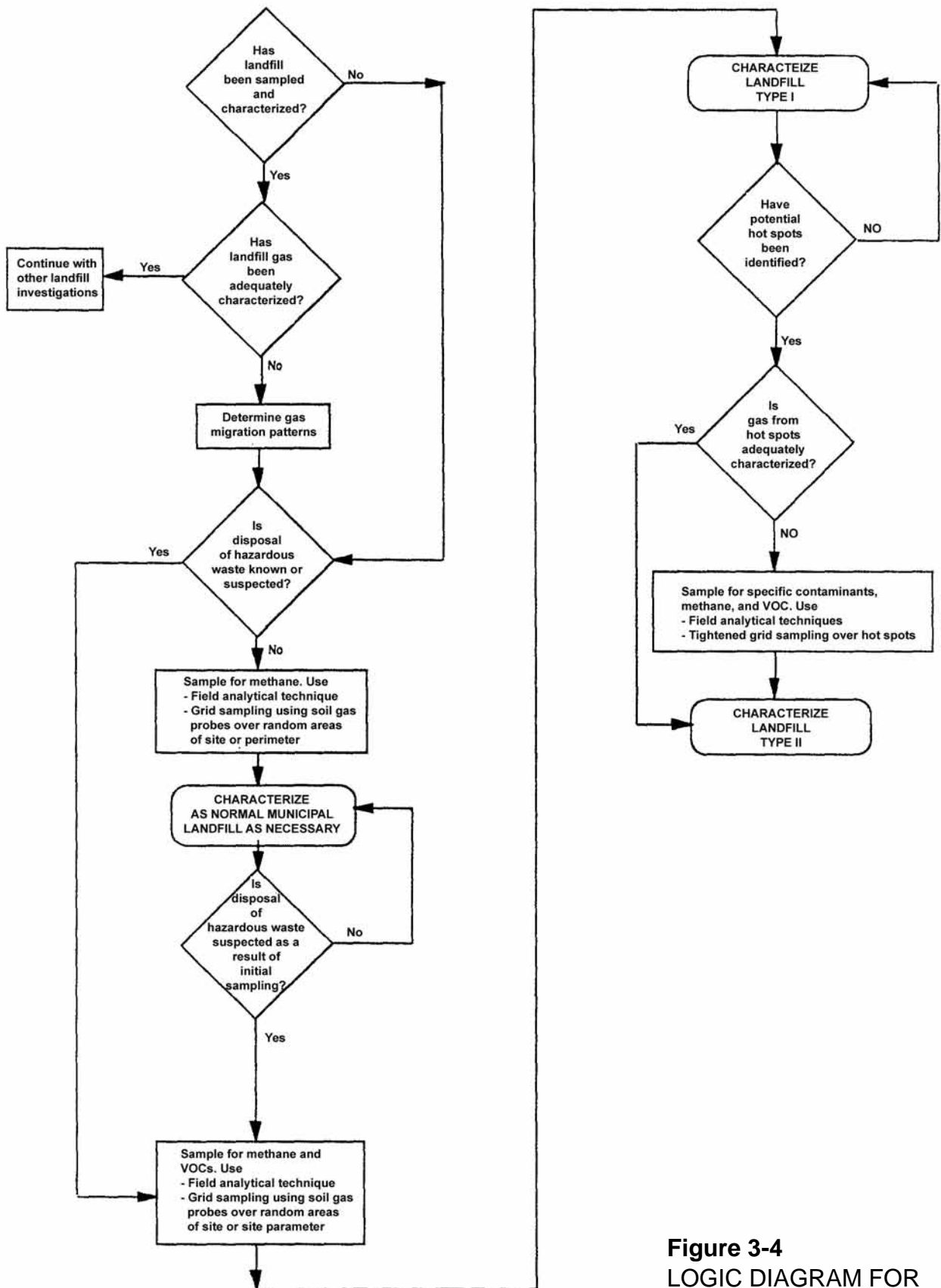

Figure 3-4
LOGIC DIAGRAM FOR
LANDFILL GAS SAMPLING

3.5.1.1 Objectives

The objectives of the environmental evaluation are to:

- Determine the impact of the site on sensitive environments (e.g., habitats, wildlife)
- Determine the impact of remedial action on wetlands or floodplains

These environmental evaluations are normally performed, if the municipal landfill is built on or next to wetlands or other sensitive environments. The principal focus of these investigations is the sediments. However, other media of concern may include surface water and aquatic species. The environmental evaluation should provide information regarding compliance with other environmental statutes, such as the Endangered Species Act, the Coastal Zone Management Act, and the Executive Order on Floodplains and Wetlands. Additional information on conducting environmental evaluations can be found in *Risk Assessment Guidance for Superfund, Volume II--Environmental Evaluation Manual* (U.S. EPA, 1989c).

3.5.1.2 Procedures

Landfill Type I. The approach to the environmental evaluation will be the same for both landfill types. A review of the data from the leachate investigation (Section 3.2.1) and the landfill content/hot spot investigation (Section 3.3.1) may be useful in determining contaminants that may affect wetland areas.

If surface water drainage patterns indicate possible deposition of contaminated sediment in a wetlands area, a minimum of one composite sediment sample from the major drainage channel and at least two background sediment samples from the wetlands area should be collected. If the composite sample is contaminated, then additional grab samples should be collected to delineate the areal extent of contamination. The number of additional samples to be collected should be determined on a case-by-case basis, depending on the potential extent of contamination.

In areas where vegetation stress is visible, composite sediment samples should be collected near the affected flora. Two background samples, if not already collected for comparison purposes, should be collected. These samples will indicate if contamination from the landfill is present that may require that biota sampling be done.

Data from other media investigations should be reviewed, because additional pathways could be identified. For example, where leachate seeps into groundwater and discharges into a wetlands area, background samples and samples of the potentially contaminated area, both sediment and groundwater, should be collected at the point of groundwater recharge.

A qualified field biologist should survey the area and note plant and animal species, if the area is indicated as a sensitive environment during the records searches or the site visit. Any remedial action alternatives considered for the site should include mitigation procedures for these sensitive environments.

Landfill Type II. The environmental evaluation will be the same for Type II landfills as for a Type I landfill. However, the investigation and remediation of hot spot areas may be a viable means of reducing or eliminating the source of wetlands contamination.

3.5.1.3 Guidelines

After data from the environmental evaluation and other media investigations are collected, an exposure assessment should be performed. The exposure assessment should particularly review potential biota targets and the probability that they will be affected by the site. If contamination is present and will harm the sensitive environments, then aquatic and terrestrial tissue sampling or acute or chronic toxicity testing should be considered to further assess the impact of the site. Biota sampling could include:

- Sampling of visibly affected plant life
- Invertebrate sampling in riverbeds
- Fish shocking, if recreational fishing area

- Capture and sampling of native wildlife, if it is known to be consumed by humans

Terrestrial and aquatic tissue sampling is labor intensive and expensive and should only be conducted if warranted by the exposure assessment. These types of studies are very rarely performed during an RI/FS. A more detailed description of collection of biota sampling is described in the documents titled *Guidance for Conducting Remedial Investigations and Feasibility Studies Under CERCLA* (U.S. EPA, 1988d), and EPA's *A Compendium of Superfund Field Operation Methods* (EPA, 1987h).

3.5.2 Data Requirements

A description of remedial action alternatives for wetlands contamination can be found in Section 4.6. To evaluate remedial action alternatives, data gathered before or during the environmental site characterization should include:

- Contaminants and concentrations in the sediments and volume of contaminated sediments to assess remedial action

alternatives

- Species of flora and fauna that may be affected by contaminants and remedial action alternatives (Fauna should include birds, terrestrial wildlife, and aquatic wildlife.)

A coordinated approach should be used when conducting an environmental evaluation, because groundwater and surface water investigations (Sections 3.1 and 3.6) often overlap environmental evaluations. For example, leachate from a municipal landfill can seep into groundwater, which recharges to a wetlands area. The groundwater investigation would identify the contamination pathway and could provide additional information on potential contamination in the wetlands. Both media characterization efforts, therefore, should be integrated.

3.5.3 Wetlands Summary

Table 3-6 summarizes the sampling rationale for an environmental evaluation, while Figure 3-5

<p align="center">Table 3-6 SUMMARY OF SAMPLING REQUIREMENTS FOR ENVIRONMENTAL EVALUATION</p>		
Media to Be Investigated	Sample Locations	Minimum Number of Samples
Wetlands	<p>Collected sediment sample from affected area and background samples.</p> <p>Collect additional sediment samples to confirm extent of contamination.</p>	<p>One composite sample per major drainage channel; two background.</p> <p>Depends on size of potentially contaminated area.</p>
Sensitive Environments	<p>Observe sample aquatic/terrestrial life in affected area.</p> <p>Collect aquatic/terrestrial life for tissue studies.</p> <p>Collect sediment sample from stressed area.</p>	<p>Depends upon biota in affected area.</p> <p>Depends upon biota in affected area.</p> <p>One composite sample per area.</p>
Groundwater (Section 3.1)	Collect surface water sediment and groundwater samples.	(See Section 3.1)

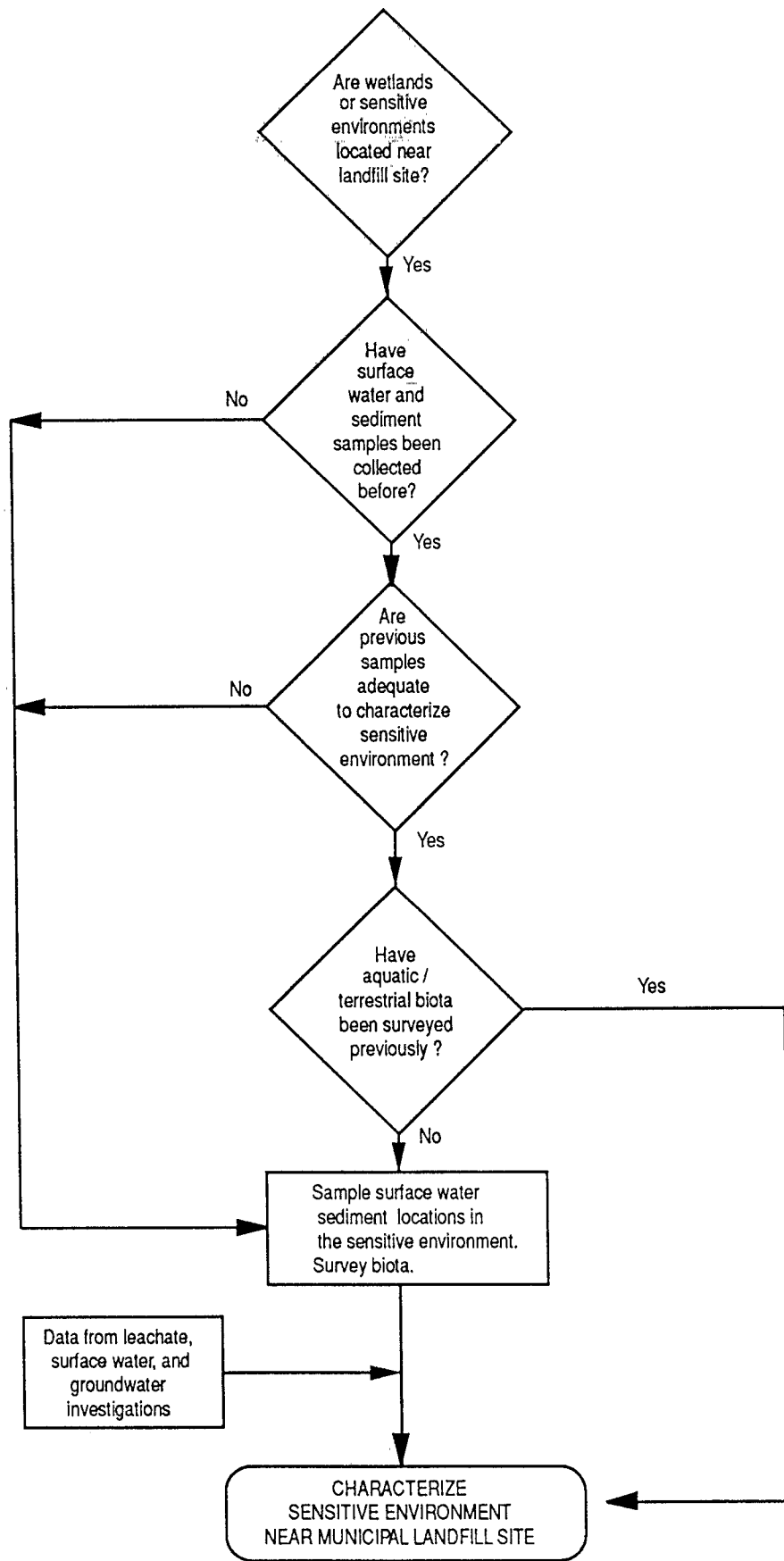

Figure 3-5
 LOGIC DIAGRAM FOR ENVIRONMENTAL ASSESSMENT NEAR MUNICIPAL LANDFILLS

shows a typical flow chart to determine sampling locations. The sampling and monitoring locations apply equally to both types of landfills.

3.6 Surface Water

Many municipal landfills are near surface water bodies, including rivers, intermittent streams, ponds, and lakes. Surface water may be contaminated by:

- Site surface water runoff
- Surface seepage of leachate
- Leachate seepage to groundwater, which recharges to a surface water body

3.6.1 Surface Water Investigation

The surface water investigation must be coordinated with the groundwater, leachate, and landfill contents/hot spots investigations (Sections 3.1, 3.2, and 3.3, respectively). The rationale for the location of surface water sampling and monitoring points is often derived from the investigation of other media.

3.6.1.1 Objectives

The objectives of the surface water investigation are as follows:

- Determine the impact of the site on surface water and sediments (e.g., from landfill runoff and leachate seeps)
- Determine contaminant concentration in upstream samples
- Evaluate surface water hydrology, including drainage patterns, flow, and surface water/groundwater relationships, as necessary
- Determine the waste characteristics of surface water and sediments
- Determine the extent of contamination and sediment volumes

- Determine the tidal or seasonal effects of the surface water on the landfill
- Determine impact of flooding on cap design and potential erosion

Much of the above information can be obtained through record searches, initial site investigations, and agencies such as the USGS, Soil Conservation Service, and other public agencies. Field investigations of water level measurements and sampling should be conducted to supplement this information (see *Guidance for Conducting Remedial Investigations and Feasibility Studies Under CERCLA* (U.S. EPA, 1988d)).

3.6.1.2 Procedures

Landfill Type I. Contamination of surface water and sediment is primarily of concern at Type II landfills. However, since unknown amounts of hazardous wastes may be commingled with municipal wastes, migration of contaminants to surface waters via leachate and runoff may also be of concern at some Type I landfill sites. The approach to both investigating surface water and sediment contamination will be similar for both landfill types. The types of surface waters that may need to be investigated at municipal landfill sites include rivers, streams, lakes, ponds, or lagoons.

Many municipal landfills are located near rivers or streams. Surface water and sediment samples should be collected upgradient (i.e., upstream) of the site, far enough to avoid any tidal influences, and downgradient of any known drainage/leachate seeps. In areas where tidal influence is a consideration, samples should be composited from several locations in both the upgradient and downgradient areas. Care should be taken so that cross-contamination of these samples by other industries or other adjacent landfills is avoided. Sediment and surface water samples should be collected upgradient and downgradient in each adjacent river or stream. Additional sampling locations might be added depending upon the size of the site, the number of rivers or streams near the landfill, and the location of drainage or leachate seeps to the river or stream.

Typical analytical parameters for surface water and sediment samples include pH, temperature, TSS, salinity, and specific contaminant concentrations. These data provide capacity of the water to carry contaminants and water/sediment partitioning (*Guidance for Conducting Remedial Investigations and Feasibility Studies Under CERCLA* (U.S. EPA, 1988d)). Specific sampling techniques are described in EPA's *Compendium of Superfund Field Operations Methods* (EPA, 1987h).

If contamination of a river is suspected or documented, river water levels and corresponding flows should be monitored upgradient from the site and downgradient from any leachate seeps or runoff. This information can be used to assess dilution effects and potential seasonal variations in contaminant concentrations due to changing water levels. Care should be taken when choosing river flow monitoring locations so that impacts from permitted or nonpermitted discharges from industries or adjacent landfills are avoided. Often, USGS and various state agencies monitor river flow at various points along major rivers or streams. These data bases can be used for water level, flow rate, and drainage data needs. The locations may not be ideal, but a water balance can provide a reasonable estimate for site characterization. If the river is not monitored, a minimum of two water level staff gauges should be installed, one upgradient from the site and one downgradient from the site in each adjacent river or stream. Precipitation data can be acquired from local weather bureaus or the National Climatic Data Center in Asheville, North Carolina.

Water level measurement frequency will depend upon the data needs of the site. At a minimum, measurements should be conducted during the surface water sampling. More frequent measurements are required to determine tidal or seasonal influences.

Some municipal landfills are located near intermittent streams. These streams often transport contamination from landfills as a result of surface water runoff during or after periods of heavy rainfall. Contamination can also be the result of an accidental release of contaminants such as

overflow of a surface impoundment. If contamination is suspected as a result of seasonal landfill runoff, surface water and sediment samples should be collected during or immediately following periods of heavy rainfall. An evaluation of the drainage patterns of the site should indicate optimal sampling locations. One sample should be collected where runoff or overflow enters the stream channel, and one sample should be collected upgradient of the site, if possible. Additional surface water samples may be collected to assess the impact of contamination from the intermittent stream on the water quality of any rivers or lakes downstream.

Intermittent streams are not usually monitored by other agencies. The stream depth, width, and flow rate during or after periods of heavy rainfall should be measured. The USGS can be consulted for estimates of water drainage in a particular area. Local weather bureaus should be contacted for precipitation data.

Many municipal landfills are situated near lakes and ponds or have small ponds on the site. Lakes and ponds are often contaminated by surface water runoff and leachate seeps from the landfill. In addition, groundwater contaminated from leachate seeps could recharge to nearby lakes and ponds.

Surface water and sediment samples should be collected near the drainage or leachate seeps and background samples should be collected upgradient of leachate seeps. Care should be taken to prevent cross-contamination from industrial dischargers and other landfills. Additional sampling may be required to assess seasonal/tidal fluctuations and multiple point discharges.

Larger surface water bodies should be monitored to determine tidal and seasonal fluctuations that affect the extent of contamination and groundwater flows. As mentioned above, the USGS and other agencies may already monitor water levels and flows to lakes. These data bases should be used. USGS data can be found in their WATSTORE files, and U.S. EPA data can be found in their STORET files. Precipitation data can be obtained from local weather bureaus or the National Climatic Data Center in Asheville, North Carolina.

Landfill Type II. For landfills that are suspected or known to have hot spot areas, investigation and remediation of hot spot areas may be a viable means of reducing or eliminating the source of contamination of surface water and sediment contamination. In some situations, hot spots may extend into surface water sediment. Information on characterizing hot spots can be found in Section 3.3.

3.6.1.3 Guidelines

Data to be collected should include sampling of potentially affected surface waters and sediments from ponds, lakes, rivers, and streams (upgradient and downgradient).

At a minimum, surface water and sediment samples should be collected near drainage or leachate seeps. Background samples should also be collected upgradient of leachate seeps and upstream of the landfill site for streams and rivers.

The determination of analytical parameters for sediment and surface water samples should correlate with leachate analysis and hot spot analysis. A review of the data generated from

the landfill contents/hot spot investigation (Section 3.3.1) and the leachate investigation (Section 3.2.1) should indicate contaminants of concern for the surface water investigation.

3.6.2 Data Requirements

Surface waters are generally not treated at municipal landfill sites. However, removal and management of contaminated sediments from surface water may be required. A description of remedial action alternatives for surface water and sediments can be found in Section 4.7. Data needs for evaluating surface water and sediment remedial alternatives can be quite extensive depending on the extent of potentially contaminated surface water at a specific site. Since surface water data needs are largely dependent on the investigation of other media, they are discussed under the surface water investigation (Section 3.6.1).

3.6.3 Surface Water Summary

Table 3-7 summarizes the recommended sampling locations for surface waters. A flowchart summarizing the decisions necessary to

Table 3-7 SAMPLING AND MONITORING RATIONALE FOR SURFACE WATER AND SEDIMENTS NEAR MUNICIPAL LANDFILL SITES		
Location	Sampling/Hydrological Monitoring Location	Considerations
Rivers	Upgradient of site, down gradient of site. Background samples.	Tidal influence, seasonal influence, leachate seeps, groundwater recharge, number of rivers/streams bordering the site.
Intermittent Streams	Upgradient and downgradient from leachate seep/surface water run-off/seep.	Seasonal influence.
Ponds	Points of known run-off/seep and background samples.	Seasonal influence, groundwater relationships, other related rivers or streams.
Lakes	Points of known run-off/seep and background samples.	Tidal influence, seasonal influence, leachate seeps, groundwater relationships, other related rivers or streams.

determine sampling and monitoring location is presented in Figure 3-6. The sampling and monitoring locations are equally applicable to both types of landfills.

3.7 Baseline Risk Assessment

Baseline risk assessments evaluate the potential threat to human health and the environment in the absence of any remedial action. They often provide the basis for determining if remedial action is necessary and the justification for performing remedial actions. The baseline risk assessment can also be used to support a finding of imminent and substantial endangerment if such a finding is required as part of an enforcement action. It should be noted that the risk assessment is performed by EPA regardless of whether it is an enforcement-lead site or not. Detailed guidance for conducting risk assessments is provided in the *Risk Assessment Guidance for Superfund, Volume I--Human Health Evaluation Manual* (U.S. EPA, 1989j); and the *Risk Assessment Guidance for Superfund--Environmental Evaluation Manual* (U.S. EPA, 1989c).

In general, the objectives of a baseline risk assessment may be attained by identifying and characterizing the following:

- Toxicity and levels of hazardous substances in relevant media (for example, air, groundwater, soil, surface water, sediment, and biota)
- Environmental fate and transport mechanisms, such as physical, chemical, and biological degradation processes and hydrogeological conditions
- Potential human and environmental receptors
- Extent of expected impact or threat; and the likelihood of such impact or threat occurring (that is, risk characterization)
- Levels of uncertainty associated with the above items

The level of effort required to conduct a baseline

risk assessment depends largely on the complexity of the site. The goal is to gather sufficient information to characterize the potential risk from a site adequately and accurately, while at the same time conduct this assessment as efficiently as possible. Use of the conceptual site model developed and refined previously will help focus investigation efforts and, therefore, streamline this effort. Factors that may affect the level of effort required include:

- Number, concentration, and types of chemicals present
- Extent of contamination
- Quality and quantity of available monitoring data
- Number and complexity of exposure pathways (including the complexity of release sources and transport media)
- Required precision of sample analyses, which in turn depends on site conditions such as the extent of contaminant migration and the proximity, characteristics, and size of potentially exposed population(s)
- Availability of appropriate standards and/or toxicity data

3.7.1 Components of the Baseline Risk Assessment

The baseline risk assessment process can be divided into four components:

- Contaminant identification
- Exposure assessment
- Toxicity assessment
- Risk characterization

A brief overview of each component follows.

3.7.1.1 Contaminant Identification

The objective of contaminant identification is to screen the information that is available on hazardous substances or wastes present at the site and to identify contaminants of concern to

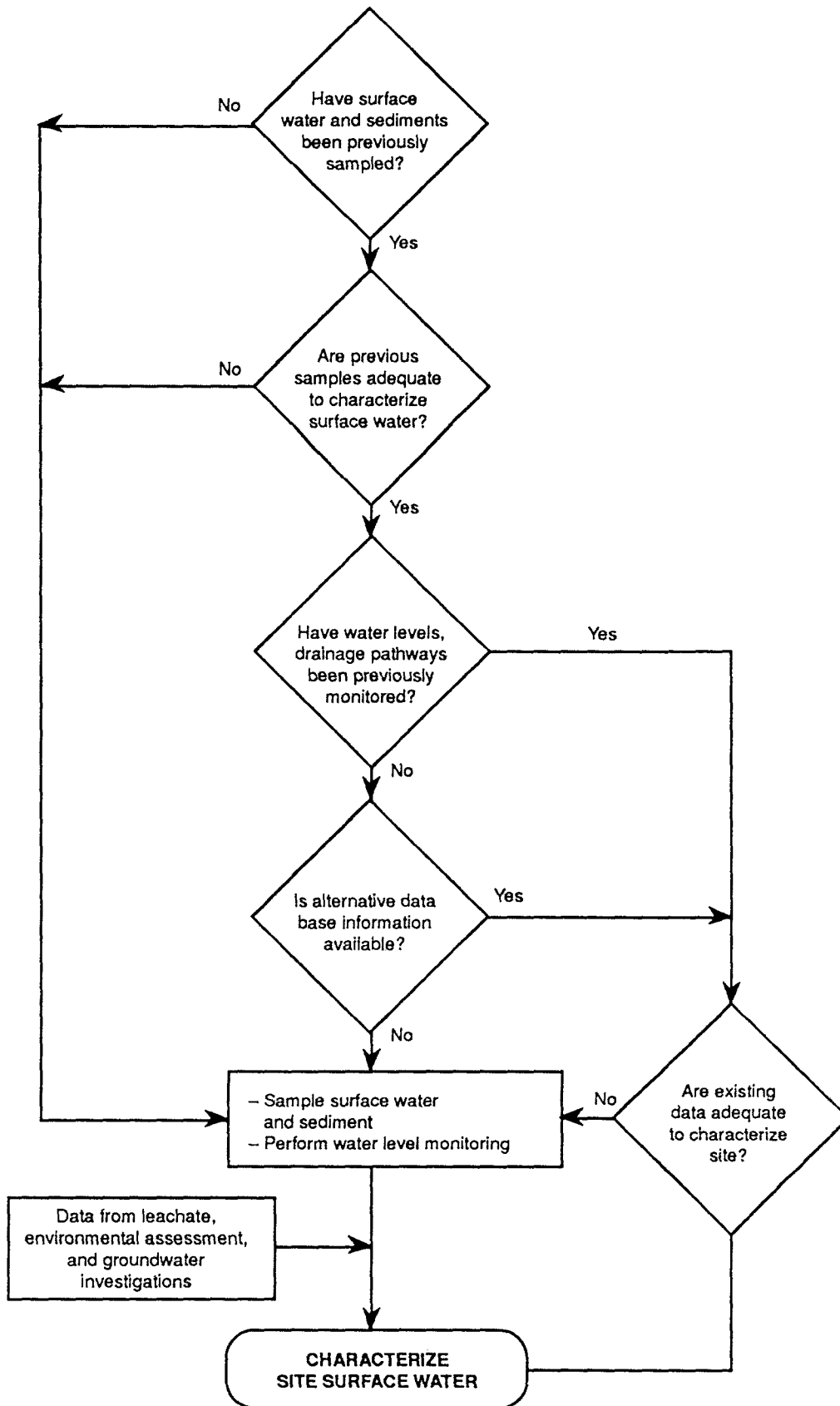

Figure 3-6
 LOGIC DIAGRAM FOR SURFACE WATER/
 SEDIMENT SAMPLING NEAR MUNICIPAL LANDFILL

focus subsequent efforts in the risk assessment process. Contaminants of concern may be selected because of their intrinsic toxicological properties, because they are present in large quantities, or because they are presently in or potentially may move into critical exposure pathways (for example, drinking water supply).

3.7.1.2 Exposure Assessment

The objectives of an exposure assessment are to identify actual or potential exposure pathways, to characterize the potentially exposed populations, and to determine the extent of the exposure. Detailed guidance on conducting exposure assessments is provided in the *Exposure Factors Handbook* (U.S. EPA, 1989dd), and in the *Superfund Exposure Assessment Manual* (U.S. EPA, 1988aa).

3.7.1.3 Toxicity Assessment

Toxicity assessment, as part of the Superfund baseline risk assessment process, considers (1) the types of adverse health or environmental effects associated with individual and multiple chemical exposures; (2) the relationship between magnitude of exposures and adverse effects; and (3) related uncertainties such as the weight of evidence for a chemical's potential carcinogenicity in humans.

3.7.1.4 Risk Characterization

In the final component of the risk assessment process, the potential risks of adverse health or environmental effects for each of the exposure scenarios derived in the exposure assessment, are characterized and summarized. Estimates of risks are obtained by integrating information developed during the exposure and toxicity assessments to characterize the potential or actual risk, including carcinogenic risks, noncarcinogenic risks, and environmental risks. The final analysis should include a summary of the risks associated with a site including each projected exposure route for contaminants of concern and the distribution of risk across various sectors of the population. In addition, such factors as the weight-of-evidence associated with toxicity information, and any uncertainties associated with exposure assumptions should be discussed.

3.7.2 Using the Baseline Risk Assessment to Streamline Remedial Action Decisions

The baseline risk assessment often provides justification for performing remedial action at a site. Once a potential risk to human health or the environment has been demonstrated, an evaluation of the appropriate remedial measures to mitigate the risk must be performed. The results of the baseline risk assessment are used in combination with chemical-specific ARARs to determine clean-up levels, which in turn help to direct appropriate remedial measures. Options for remedial action at municipal landfill sites, however, are often limited. Therefore, in many cases, it may be possible to streamline or limit the scope of the baseline risk assessment in order to initiate remedial action on the most obvious landfill problems (groundwater/leachate, landfill contents, and landfill gas). Ultimately, it will be necessary to demonstrate that the final remedy, once implemented, will address all pathways and contaminants of concern, not just those that triggered the need for remedial action.

Rapid implementation of protective measures for the major problems at a landfill site may be accomplished by:

1. Using the conceptual site model and RI-generated data to perform a qualitative risk assessment that identifies contaminants of concern in the affected media, contaminant concentrations, and their hazardous properties that may pose a risk through the various routes of exposure.
2. Identifying pathways that are an obvious threat to human health or the environment by comparing RI-derived contaminant concentration levels to standards that are potential chemical-specific applicable or relevant and appropriate requirements (ARARs) for the action. These may include:
 - Non-zero maximum contaminant level goals (MCLGs) and MCLs for groundwater and leachate (40 CFR 300.430(e))
 - State air quality standards for landfill gas

When potential ARARs do not exist for a specific contaminant, risk-based chemical concentrations should be used.

Where established standards for one or more contaminants in a given medium are clearly exceeded, remedial action is generally warranted (quantitative assessments that consider all chemicals, their potential additive effects, or additivity of multiple exposure pathways are not necessary). In cases where standards are not clearly exceeded, a more thorough risk assessment may be advisable before deciding whether or not to take remedial action.

The benefits of performing early or interim actions at a landfill site include speeding up the clean-up process and reducing the impact on other affected media (e.g., wetlands) at a site while the RI/FS continues. The effect of early action at a landfill should be factored into any ongoing risk assessment. For example, if leachate seepage that had been contaminating surface water and wetlands is stopped as a result of an early action, then the risk assessment developed subsequently for the stream sediments and wetlands should assume no further loading. Any early actions also need to be designed for flexibility so that they will be consistent

with subsequent actions. For example, it may be necessary to adjust a groundwater pump-and-treat early action designed to attain MCLs to achieve even lower levels, determined to be necessary under a subsequent risk assessment, in the interest of protecting environmental receptors in the wetlands into which the groundwater discharges.

Although this process allows for early implementation of remedial measures, a risk assessment will be required to demonstrate that the final remedy at the site is protective of human health and the environment.

3.8 Section 3 Summary

This section provides information on how to characterize CERCLA municipal landfill sites so that site dynamics and site risks can be defined. Also included in this section is a description of the baseline risk assessment for municipal landfills. Section 4 describes technologies most practicable for remediating CERCLA municipal landfill sites. The information in these two sections can then be used to assist in the development of appropriate remedial action alternatives to mitigate potential adverse human health and environmental impacts of municipal landfill sites.

Section 4

DETAILED DESCRIPTION OF TECHNOLOGIES

4.1 Remedial Action Objectives

Because many CERCLA municipal landfill sites share similar characteristics, they lend themselves to remediation by similar technologies. EPA has established a number of expectations as to the types of remedial alternatives that should be developed during the detailed analysis stage; they are listed in the National Contingency Plan (40 CFR 300.430(a)(1)). For municipal landfill sites, it is expected that:

- The principal threats posed by a site will be treated wherever practical, such as in the case of remediation of a hot spot.
- Engineering controls such as containment will be used for waste that poses a relatively low long-term threat or where treatment is impractical.
- A combination of methods will be used as appropriate to achieve protection of human health and the environment. An example of combined methods for municipal landfill sites would be treatment of hot spots in conjunction with containment (capping) of the landfill contents.
- Institutional controls such as deed restrictions will be used to supplement engineering controls, as appropriate, to prevent exposure to hazardous wastes.
- Innovative technologies will be considered when such technologies offer the potential for superior treatment performance or lower costs for performance similar to that of demonstrated technologies.

- Groundwater will be returned to beneficial uses whenever practical, within a reasonable time, given the particular circumstances of the site.

As a first step in developing remedial action alternatives, remedial action objectives need to be developed. Typically, the primary remedial action objectives for remediating municipal landfill sites include:

- Preventing direct contact with landfill contents
- Reducing contaminant leaching to groundwater
- Controlling surface water runoff and erosion
- Remediating hot spots
- Collecting and treating contaminated groundwater and leachate
- Controlling and treating landfill gas
- Remediating contaminated surface water and sediments
- Remediating contaminated wetland areas

Based on the above remedial action objectives for CERCLA municipal landfill sites and the EPA expectations outlined in the NCP, the following points should be considered in order to streamline the development of remedial action alternatives:

- Generally, the most practicable remedial alternative for landfills is containment (capping). Depending on site characteristics, containment could range from a soil cover to a multi-component impermeable cap.
- Treatment of soils and wastes may be practicable for hot spots. Consolidation of hot spot materials under a landfill cap is a potential alternative in cases when treatment is not practicable or necessary.
- Extraction and treatment of contaminated groundwater and leachate may be required to control offsite migration of wastes. Additionally, extraction and treatment of leachate from landfill contents may be required. Collection and treatment may be necessary indefinitely because of continued contaminant loadings from the landfill.
- Constructing an active landfill gas collection and treatment system should be considered where (1) existing or planned homes or buildings may be adversely affected through either explosion or inhalation hazards, (2) final use of the site includes allowing public access, (3) the landfill produces excessive odors, or (4) it is necessary to comply with ARARs. Most landfills will require at least a passive gas collection system (that is, venting) to prevent buildup of pressure below the cap and to prevent damage to the vegetative cover.

A review of the selected remedies in the records of decision (RODs) EPA has signed through FY 1989 for CERCLA municipal landfill sites indicates that certain technologies are implemented more often than others (Appendix B). Based on this review of technologies used most frequently at CERCLA municipal landfill sites and, based on the NCP expectations, a list of technologies has been developed. The descriptions in this section of these technologies is intended to streamline the RI/FS process by making available a list of technologies practical for use at CERCLA municipal landfills. The list of technologies described in this section is not intended to alleviate

the responsibility of the feasibility study team to consider other, possibly appropriate technologies. Design considerations and data needs have also been included to help guide the data-gathering tasks associated with remedial investigations.

The technology discussions have been grouped by media for organizational reasons. However, the interactions between media should be considered when assembling technologies into alternatives. For example, leachate, contaminated groundwater, and landfill gas condensate may all require treatment using some or all of the same processes.

While the descriptions focus primarily on technologies used at landfill sites, brief descriptions of surface water and groundwater remediation are included. Often, contamination of these media must be addressed, although the nature of the remedial alternatives is not necessarily unique to landfill sites. Likewise, mitigation of wetlands is addressed because a significant number of municipal landfill sites are located within or close to wetlands.

4.2 Landfill Contents

4.2.1 Access Restrictions

Access restrictions at municipal landfill sites are intended to prevent or reduce exposure to onsite contamination. They include actions such as fencing, signage, and restrictive covenants on the property deed to prevent development of the site or use of groundwater below the site. Access restrictions may also be imposed to reduce required maintenance and to protect the integrity of a remedial alternative such as a landfill cap. Some of the conditions at a municipal landfill site that may warrant access restrictions include:

- Landfills where no cap has been constructed
- Landfills where passive venting of landfill gas is being used or cases where no landfill gas controls have been implemented and gas emissions may be a health hazard

- Landfills where erosion of the cover may be of concern (limit all-terrain vehicles, vehicular traffic, creation of foot paths, etc.)
- Landfills where liability concerns may warrant limiting access

Situations where access restrictions such as fencing may not be necessary include:

- Rural areas where heavy use is unlikely and where occasional trespassing, such as for hunting, does not present a risk
- Urban areas in situations where the landfill is capped and landfill gas does not present a significant risk and where the local community may desire that the land be used for an appropriate purpose such as a park area. In cases where fencing is not necessary, it may still be prudent to post signs to warn trespassers of potential risks.

The two types of access restrictions most used at municipal landfill sites include deed restrictions and fencing. Conditions in the area of the site should be evaluated in the 5-year reviews to assess the continuing or future need for access restriction.

4.2.1.1 Deed Restrictions

Restrictive covenants on deeds to the landfill property are intended to prevent or limit site use and development. Restrictive covenants, written into the landfill property deed, notify any potential purchaser of the landfill property that the land was used for waste disposal and that the land use must be restricted in order to ensure the integrity of the waste containment system. The effectiveness of deed restrictions depends on state and local laws, continued enforcement, and maintenance. Most restrictions are subject to changes in political jurisdiction, legal interpretation, and level of enforcement. Some, such as aquifer use restrictions, are voluntary and are not enforceable. In addition, some states do not allow deed restrictions to be placed on properties due to inherent problems associated with enforcement.

Because deed restrictions are generally used in conjunction with other remedial actions, the specific prohibitions outlined in the restrictive covenant are based on the type of remedial action implemented at the site and how the effectiveness of that remedial action can be improved through deed restrictions. For municipal landfill sites, the major purpose of deed restrictions is to protect the integrity of the cap. The restrictive covenant should limit subsurface development (excavation), excessive vehicular traffic (including off-road vehicles and dirt bikes), and groundwater use. Additional deed restrictions may be required for effective implementation of other technologies. The permissible uses/limitations for the specific landfill property should be identified based on the risk the site poses and the remedial actions likely to be implemented.

4.2.1.2 Fencing

When necessary, fencing is used to physically limit access to the landfill site. Signs may be posted to make clear to potential trespassers that there may be a health threat associated with going on the site. Signs typically are posted at equal intervals along the perimeter of the site and along roads leading to the site. The most common type of fence used to limit access is a chain-link fence about eight feet high. Barbed wire on top of the fence may also be required to deter trespassing. Gates alone may be sufficient if only vehicular traffic needs to be limited. The primary data needed for fence evaluation is a determination of the area to be fenced. First, however, the location and potential risks of the landfill site, along with local land use restrictions, should be identified to determine whether fencing is necessary at all.

4.2.2. Containment

Containment refers to technologies that isolate the landfill contents and mitigate offsite migration through the use of engineering controls. Containment technologies include surface controls and capping.

4.2.2.1 Surface Controls

Surface control technologies are designed to control and direct site runoff (potentially for

treatment) and to prevent offsite surface water from running onto the site. These technologies reduce water infiltration into the waste and associated leachate generation, and slow down the rate of cap erosion. Surface controls to divert run-on and minimize infiltration at municipal landfill sites often are implemented in conjunction with site closure. Such controls are almost always employed in concert with other technologies such as installation of a landfill cap. Landfill covers, like any other disturbed soils, are prone to erosion, which can result in exposing and eventually mobilizing contaminated materials. Therefore, if necessary, erosion and sediment controls should be considered, including space requirements for sedimentation basins and erosion control structures. Surface controls most commonly used at municipal landfill sites are grading and revegetation.

Grading. Grading modifies topography in order to promote positive drainage and control the flow of surface water. A properly graded surface will channel uncontaminated surface water around the landfill, thereby minimizing infiltration through the landfill cap.

Grading is also the general term for techniques that reshape the surface of landfills in order to control erosion and to manage surface water infiltration, run-on, and runoff. Designing proper slope lengths and gradients, and creating berms and swales are common grading techniques used to control and route surface water. Earth fill, typically from offsite borrow sources, may be required to change slope gradients and to construct earthen berms. Regrading existing fill material is recommended in situations where there is a significant quantity of fill, if analysis shows the fill is acceptable to reuse. Significant cost savings could be made by using existing fill and thereby minimizing the cost of transporting fill material from an offsite source.

Generally, slopes on top of the landfill range from 3 percent to 8 percent in order to promote runoff and control erosion. Sideslopes can be as steep as 3H:1V (33 percent) as long as benches (horizontal steps) are provided to interrupt the slopes and thus control soil erosion and maintain slope stability. Steeper slopes can exist under certain slope conditions.

However, the use of slopes less steep than 3H:1V is recommended.

Municipal solid wastes usually settle during the life of a landfill due to decomposition of organic wastes and the weight of superimposed loads of refuse and soil. The settlement may be significant, especially in the deepest points of the landfill which typically are located at the center of the landfill. Settlement can result in changing surface slopes and possibly flattening some of these slopes. A well prepared grading plan will take settlement into account by recommending slopes that will still be effective after settlement. Potential settlement problems can be identified by placing benchmarks that can be surveyed at various times throughout the RI/FS process. Continued operations and maintenance (O&M) will also be required to maintain adequate surface slopes.

Grading techniques are well developed and commonly used in landfills around the U.S. They are often performed in conjunction with capping and revegetation and have a considerable impact by reducing leachate generated due to infiltration.

Some implementation and O&M considerations concerning an adequate grading plan include the following:

- A well designed grading plan should result in runoff from the site being controlled. Also, water that would otherwise run onto the site will be diverted.
- A properly graded site will reduce the contact time of runoff water on the landfill, thus reducing the rate of infiltration of surface water into the landfill.
- Erosion of cover soil can be controlled through grading, and soil retention will encourage the growth of beneficial vegetation.
- The cost of earth fill may be high, especially when the borrow source is remote. Free fill may be available from large construction projects.

- There will be a need for ongoing maintenance because soil erosion and settlement of waste can change the slope gradient.
- Some of the benefits such as reduced infiltration rate or reduced volume of leachate can be hard to quantify in landfills where there is no leachate collection system.

In order to develop an adequate grading plan, the following data should be gathered:

- Likely distance to borrow source
- The extent to which the existing fill could be used as part of the grading plan
- Existing topography and boundary of project earthworks (area to be graded)
- Climatological data (for example, precipitation)
- Stormwater retention and sedimentation boring requirements
- Soil data for the grading soil (for example, runoff curve number, permeability, grain size distribution)
- Slope length and gradient limits--for example, maximum and minimum length and gradient. (Top slopes range from 3 percent to 8 percent; sideslopes, if lined, typically are not steeper than 3H:1V, with a bench for every 25-foot rise in elevation.)
- Maximum allowable erosion per acre--typically, 2 tons per acre per year (U.S. EPA, 1989d).
- Maximum stormwater flow velocity and type of material available for ditch lining. Ditch or channel protection depends mainly on the type of soil where the channel is being excavated (for example, grass, gravel, gabions, grouted gabions, concrete, plastic lining, etc.). For example, channels

excavated in fine gravel will require lining when flow velocity exceeds 2.5 feet per second, while alluvial silts can withstand velocities up to 2.7 feet per second without lining.

Revegetation. Revegetation is a method used to stabilize the soil surface of a landfill site and promote evapotranspiration. Revegetation decreases erosion of the soil by wind and water, reduces sedimentation in stormwater runoff, and contributes to the development of a naturally stable surface. It is also used to improve the aesthetics of the landfill, which is especially important when the site is being considered for use as recreational land.

Revegetation is used as a temporary measure to stabilize the soil surface or as a permanent feature when the closed landfill site is being reclaimed for other uses. A systematic revegetation plan includes selection of a suitable plant species, seedbed preparation, seeding/planting, mulching and/or chemical stabilization, fertilization, and maintenance.

Revegetation is used most in concert with other containment technologies such as caps. Since most caps include an impermeable layer, revegetation may require a drainage layer over the impermeable layer to avoid rotting of the plant roots. In dry climates, irrigation may be necessary at times to maintain strong plants. Trees and shrubs with deep roots that might penetrate the impermeable cover layer should be prevented from growing on landfill covers.

Some implementation and O&M considerations concerning revegetation include the following:

- Revegetation will reduce soil erosion by wind and water, improve site aesthetics, and increase evapotranspiration due to plants.
- The requirement for periodic maintenance (such as mowing) should be considered.
- The potential need for irrigation, which is costly and may conflict with objectives of reduced infiltration, should be considered.

Some plant species commonly used for revegetation include Kentucky bluegrass, tall fescue, meadow fescue, redtop bentgrass, smooth brome grass, field brome grass, orchard grass, annual ryegrass, timothy, and red canary grass. Revegetation typically includes grass and legume mixtures. Revegetation species can be selected using the state's Soil Conservation Service guidelines. Also, the EPA Office of Research and Development has developed a computer model, titled *Veg Cover*, which can be used to provide information on the selection of revegetation species. Additionally, the type of plant species to be used in different climates and conditions can be found in *Design and Construction of Covers for Solid Waste Landfills* (U.S. EPA, 1979a).

The type of plant species selected for revegetation depends on a number of factors. Primary data needs for determining an appropriate plant species for revegetation are:

- Type of seeding--temporary or permanent
- Time of year when the seeding is to be performed
- Type of climate at the landfill (annual precipitation, low/high temperatures)
- Topographic characteristics (for example, slope steepness, drainage patterns)
- Soil characteristics (for example, nutrients, pH, moisture content, organic content, grain size distribution)

Other factors that should be considered in selecting a plant species include:

- Minimizing the level of maintenance required after seeding
- Effects of increased surface soil permeability due to root system and possible increased infiltration through the cover

4.2.2.2 Cap (Landfill Cover)

The selection of an appropriate cap design will depend not only on the technical objectives but also on risk factors and the identified ARARs for the landfill site. A discussion and some examples of potential ARARs for municipal landfill sites are presented in Section 5. Additional guidance for determining requirements to CERCLA sites can be found in the *CERCLA Compliance with Other Laws Manual: Part I* (U.S. EPA, 1988c).

A determination should be made on which RCRA closure requirements are relevant and appropriate for the specific site of concern. RCRA Subtitle D closure requirements are generally applicable unless a determination is made that Subtitle C is applicable or relevant and appropriate. In general, RCRA Subtitle C would be applicable if the waste is a listed or characteristic waste under RCRA, and the waste was disposed of after November 19, 1980 (effective date of RCRA) or the response action constitutes treatment, storage, or disposal, as defined by RCRA. The decision about whether a RCRA requirement is relevant and appropriate is based on consideration of a variety of factors, including the nature of the waste and its hazardous properties, and the nature of the requirement itself. State closure requirements that are more stringent than the Federal requirements must be used in determining a final cover design. These regulatory requirements should be integrated with the technical objectives for the site, based on site characteristics, to determine the best capping alternatives to be evaluated in detail.

Capping technologies may be designed to reduce surface water infiltration, control emissions of gas and odors, reduce erosion, and improve aesthetics. Capping technologies also provide a stable outside surface that prevents direct contact with wastes. The different types of capping technologies typically used at landfills include:

- Native soil cover
- Single barrier (e.g., clay)
- Composite barrier (e.g., clay plus FML)

Figure 4-1 is a simplified decision tree for determining an appropriate profile cap based on site and waste characteristics.

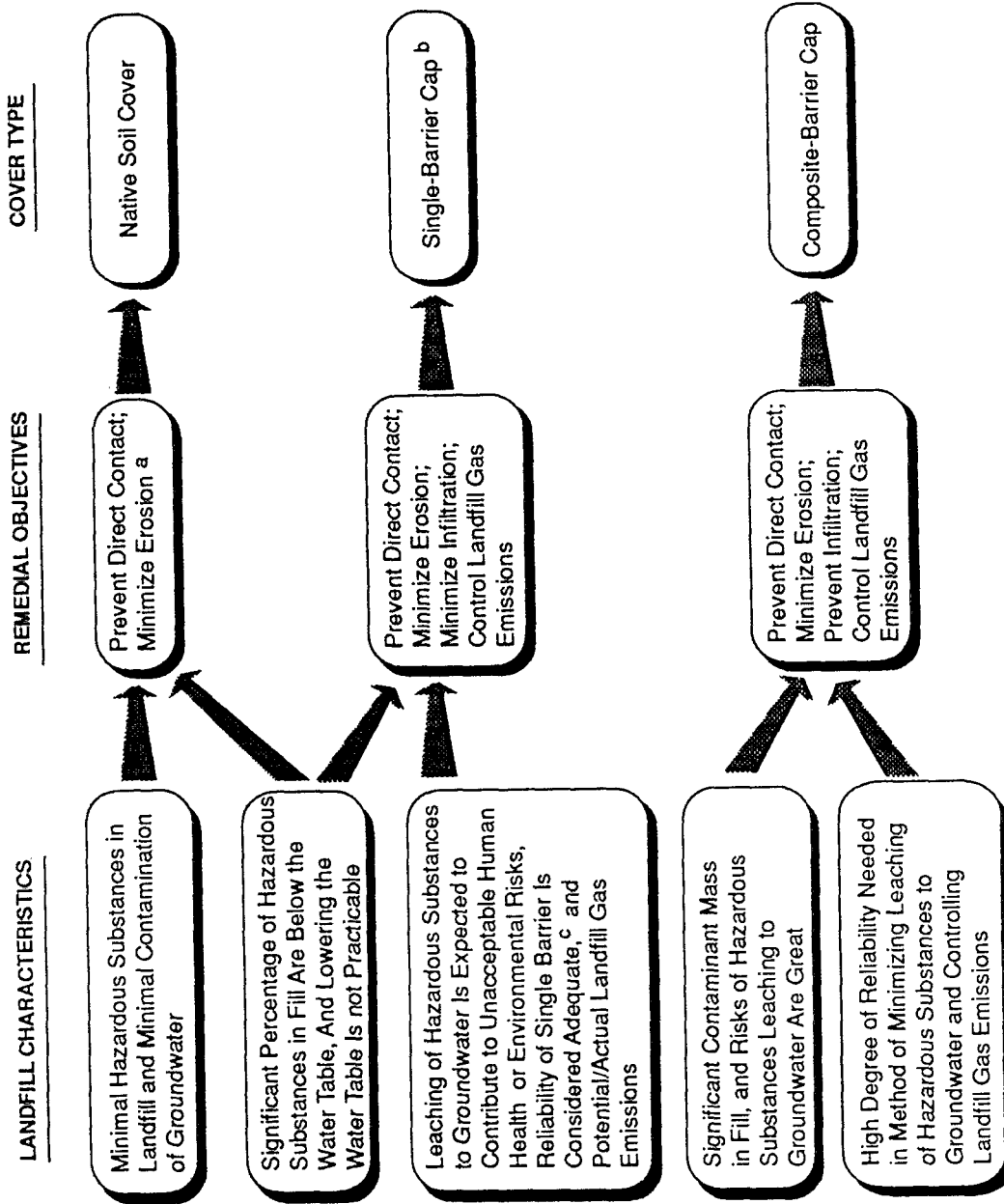

- a Primary objective is to prevent direct contact, although the soil cover can be designed to reduce infiltration.
- b Single-barrier caps may include additional layers that provide protection to that barrier.
- c Examples include situations where infiltration is not the primary concern and may include sites containing a small volume of contaminant mass, regions with low annual precipitation, or sites where groundwater is not being used as a source of drinking water.

Figure 4-1
LANDFILL COVER SELECTION GUIDE

The primary data needed for designing a cap system include:

- Depth to groundwater beneath waste (caps may be of limited benefit in areas of high groundwater if they are the only remedial action used)
- Availability of cover materials (caps may be high in cost if the desirable material is not locally available)
- Rate or magnitude of waste settlement under the cap (changes in waste thickness, degree of decomposition, and potential presence of large, near-surface voids should be known)
- Steepness of slopes
- Cover soil characteristics
 - Proctor compaction Properties
 - Permeability
 - Grain size gradation
 - Shear Strength
 - Atterberg limits
 - Field moisture capacity
- Maximum frost depth at the location of the site
- Anticipated weather conditions at the site (for example, temperature, precipitation, wind)
- Proximity to residential, commercial, or industrial units
- Future land use of the site

The efficiency of the covers may be calculated using EPA's computer model, HELP (hydrologic evaluation of landfill performance). HELP is a quasi-two-dimensional hydrologic model of vertical water movement through the landfill cap. The model accounts for the effects of surface water runoff, evapotranspiration, soil moisture storage, and lateral flow through drainage layers to predict the rate of water infiltration through covers. The HELP model is available from EPA's Risk Reduction and Engineering Laboratory (RREL) in Cincinnati, Ohio.

Soil Cover. The use of native soil (nonclays) as cover for containment of wastes may be appropriate in arid climates where surface water infiltration (and subsequent leachate generation) is not a controlling factor. Native soil caps are used when the primary objective is to control erosion and prevent direct contact. However, in regions having more evapotranspiration potential than rainfall, native soil covers can be engineered to also reduce infiltration. This is accomplished by incorporating field storage capacity within the cap sufficient to store the largest seasonal inflow event. Such water balance designs can be performed and verified using the HELP model. Native soil covers may also be appropriate on stabilized or solidified wastes, or as temporary caps to prevent direct contact with wastes. A temporary cap as an interim action may be warranted in situations where the settlement rate of the landfill contents has not stabilized.

Native soils used to reduce the rate of infiltration in arid regions typically have high field storage capacities (for example, 0.3 vol/vol). Soils with high field storage capacity have a high percentage of fine material (passing U.S. No. 200 sieve; for example, silts and sandy silts). Also, native soils can be mixed with additives and mechanically compacted to lower their permeability and make them more suitable for reducing infiltration. The required field storage capacity and permeability of soil that is used to reduce infiltration depends on the following factors:

- Climatological data for the region where the landfill is located (for example, precipitation for the design storm event, temperature, and depth of evaporative zone)
- Characteristics related to the type and condition of vegetation that is expected to be planted (for example, evapotranspiration)
- Physical characteristics of the site (for example, slope gradient and thickness of native soil layer)

Unless a water balance analysis is performed as part of the design of a native soil cover, the

native soil cover provides only separation, protection, and/or a vegetative layer. Generally, native soils are suitable for vegetation due to their high organic content. A typical native soil cover that provides these limited functions is 18 to 24 inches deep, has a permeability less than or equal to 1×10^{-5} cm/sec, and a field storage capacity less than 0.3 vol/vol.

Implementation and O&M considerations concerning native soil covers include the following:

- Soil covers are generally low in initial cost.
- Construction materials generally are readily available from local sources.
- Soil covers usually should be vegetated to minimize erosion.
- Unless designed to do so, soil covers are not very effective in reducing infiltration. (If reduced infiltration is the design goal, field permeability testing should be performed prior to construction to verify that the expected low permeability can be achieved.)
- Erosion can expose waste if cover is not adequately maintained through continued O&M.
- Native soil may not be naturally useful as a barrier layer in many cases and may require processing.
- Native soil may not be stable on steep slopes (greater than 33 percent); therefore, constructibility may limit the slope to less than 25 percent.

Single Barrier. The main functions of a single barrier landfill cap are to reduce surface infiltration, prevent direct contact, limit gas emissions, and control erosion. The two most commonly used barrier layers are clay soils and FMLs. Both serve as low-permeability barrier layers that reduce surface water infiltration into the landfill. The barrier layer is usually overlain by a drainage layer and/or a vegetative/ protective layer. A water balance analysis must be performed if a drainage

layer is incorporated into the cap. The clay materials generally used are natural clays but also can be processed clay minerals such as bentonite mixed with native soils. The clay barrier must have a permeability less than 1×10^{-7} to be effective as a barrier. If bentonite is used, the high shrink-swell potential needs to be considered.

Clay materials can achieve very low permeabilities (e.g., 1×10^{-7} cm/sec) if they are well compacted and if their moisture content is optimum, as determined in the laboratory. Upon surface drying, clayey soils form desiccation cracks that can allow surface water to infiltrate. Also, in cold climates, clay may be damaged by freeze-thaw action unless it is buried below the frost depth. In order to prevent surface drying, a layer of cover soil should be placed over the clay layer to aid in maintaining the clay's moisture and to provide a base for revegetation. Also, a soil cover layer can prevent freeze-thaw damage to the clay if the cover layer is of a depth equal to or greater than the local maximum frost depth.

FMLs, on the other hand, are synthetic materials that, if punctured, can allow surface water to permeate into the landfill. A cover of soil over the FML, as well as a bedding layer under the FML, is necessary to protect the integrity of the liner and to allow for revegetation.

Recently, bentonite panels have been marketed for use as liners for municipal landfill sites. Previously, these panels have been used for lining impoundments and lagoons, waterproofing structures, lining spill containment areas, and similar uses. The panels consist of a dry granular sodium bentonite layer approximately 1/4 inch thick with a woven geotextile on each side which allows some bentonite, upon hydration, to seep through the mesh to facilitate a seal between overlapping panels. When hydrated, the bentonite is capable of expanding up to 15 times its former volume if unconfined. This characteristic provides a seal when the material is confined and provides some self-healing at small holes or penetrations. Several landfill sites are presently using these panels with apparent success. However, use of these panels may require demonstration to the appropriate regulatory agencies that the preferred

liner system will meet the performance objectives of the applicable regulations, even if the regulations, as written, are not met. Care must be used in applications of bentonite board barriers on slopes. As the bentonite hydrates, its shear strength decreases and slope failures may result.

Weather conditions must be considered when constructing a landfill cap. If clay is used, dry, windy climates make moisture control difficult. Freezing temperatures, rain, and excessive natural moisture make proper placement of clay difficult. FML installation is not affected as much by hot, dry, or wet weather, but wind and cold temperature can cause problems. Caution must be used in wet weather, however, to ensure the integrity of FML seams. The FML must be dry for proper seaming.

Subgrades for both clay and FML barrier layers must be prepared to provide a sound foundation for the barrier layer. This may require stripping existing vegetation, scarifying and compacting existing cover soils, or placing and compacting a layer of fill. The integrity of the foundation layer should be verified by proof rolling, when possible. Visible soft zones should be excavated and recompacted. A smooth steel roller should be used to dress the surface of the subgrade before placement of an FML.

A typical cross section of a single-barrier cap consists of the following layers (from visible top to top of waste):

- Vegetative and protective layer--24 inches of native soil
- Optional drainage layer--12 inches of sand (permeability 1×10^{-2} cm/sec) or a composite drainage net
- Barrier layer--24 inches of clay (permeability 1×10^{-7} cm/sec) or a 30-mil (minimum) FML
- Bedding layer--12 to 24 inches of compacted select native soil or sand subgrade

Regulations of individual states or specific applications may require a different cross section; however, the function of the above-described system would meet the intent of most requirements of a single-barrier cap.

Some implementation and O&M considerations concerning single-barrier caps include the following:

- Either a clay or FML cap should result in low permeability and reduction of infiltration.
- There is a known history of operating and placement experience for both clay and synthetic liners.
- A single barrier clay cap can be relatively low in cost if clay is locally available. However, it may be very expensive if the borrow source is remote.
- Several choices of materials are used to manufacture FMLs (e.g., PVC, HDPE, etc.) depending on the specific application. The selection of material is usually made during design.
- An FML cap may be more difficult to repair than a clay cap.
- A clay cap may be made less permeable by increasing bentonite admixture.
- A clay cap and an FML require careful placement with strict QA/QC, especially around any gas vents.
- Both FMLs and clays may react to chemical attack and become more permeable.
- Clay caps require careful design and strict QA/QC. Field permeability tests should be conducted before construction to verify that the desired low permeability criterion can be achieved using the specified material and equipment.

- Clay caps may be subject to damage by weather elements (freeze-thaw and surface drying).
- Problems may rise with clay or FML caps and/or drainage layers in cases where substantial landfill settlement is expected.
- In some cases, it may be useful to construct a temporary cover until the rate of settlement subsides and then construct a final cap.

Composite Barrier. A composite-barrier cap provides an additional barrier layer, which reduces the rate of infiltration more than a single-barrier cap does. A composite barrier consists of a compacted clay layer overlain by a synthetic liner (FML). The composite barrier, in turn, is overlain by an optional drainage layer and by a top vegetative/protective layer.

- The vegetative/protective layer provides stability and erosion control. It also provides protection for the synthetic liner and for the drainage layer.
- The synthetic or natural drainage layer provides drainage of infiltration water in order to maintain a hydraulic head of no more than 1 foot on top of the synthetic liner barrier.
- The synthetic and clay barrier layers provide maximum infiltration protection.
- The subgrades under the bottom barrier layer and otop of the waste provide a bedding layer and can act as a gas collection layer, if required.

A composite-barrier cap is to be used when the landfill contains RCRA listed wastes, waste sufficiently similar to RCRA listed waste, or RCRA characteristic waste. The need for a composite-barrier cap in cases where landfills contain much lower concentrations of hazardous contaminants than that of RCRA characteristic or listed wastes must be judged on a site-specific basis and may depend on factors such as site

characteristics and potential receptors. Composite-barrier caps are also required in some states (New York 6NYCRR Part 360) for closure of municipal solid waste facilities.

RCRA provides technical guidance (U.S. EPA, July 1989d) that defines the types of layers EPA considers to be appropriate for a cap for new RCRA landfill cells. This guidance is a TBC (to be considered) and is intended to meet the RCRA regulations requiring a cap of equal or lower permeability than underlying liners or native soils. The minimum thicknesses for the layers in a RCRA cap (from visible top to top of waste) are as follows:

- Vegetative and protective layer--24 inches of native soil
- Drainage layer--12 inches of sand (permeability $\leq 1 \times 10^{-2}$ cm/sec) or geonet (transmissivity $\leq 3 \times 10^{-5}$ m²/sec)
- First barrier layer component--FML (20-mil minimum)
- Second barrier layer component--24 inches of clay (permeability $\leq 1 \times 10^{-7}$ cm/sec)
- Bedding layer (optional)--12 inches of native soil or sand subgrade

The final design profile of a typical composite cap will also include geotextiles as a filter between the protective cover and the drainage layer and as a protective layer over the synthetic barrier if a layer of natural drainage stone is used. A geosynthetic must not be placed between the two barrier layers or the effectiveness of the composite will be compromised. Multilayer caps pose a stability problem on slopes. Laboratory direct shear tests must be performed to measure the interface friction angles between the various layers. To ensure stability, a slope stability analysis should be performed for each interface.

Some implementation and O&M considerations concerning composite-barrier caps include the following:

- A composite barrier provides enhanced protection against infiltration.
- Onsite material potentially can be used for some of the layers.
- A composite-barrier cap will meet RCRA requirements for new landfill cells.
- Construction requires strict QA/QC.
- Stability problems may occur on sideslopes greater than 10 percent.
- Problems may arise with clay layers, synthetic barriers, and/or drainage layers in cases where substantial landfill settlement is expected.
- Lysimeters may be useful to monitor the cover performance (leak detection) where cover stability is uncertain.
- In some cases, it may be useful to construct a temporary cover until the rate of settlement subsides and then construct a final composite-barrier cap.

4.2.3 Removal/Disposal

Removal of contaminated soils at municipal landfill sites is generally limited to hot spots or, when practicable, to landfills with a low to moderate volume of waste (e.g., less than 100,000 cubic yards). Complete excavation of the municipal landfill contents is often not considered practicable because of the large volume of waste typically found at CERCLA municipal landfill sites. No examples of complete excavation were found in the review of remedial actions outlined in the RODs listed in Appendix B.

As previously stated, hot spots that are appropriate for excavation and removal should be indiscrete, accessible locations of a landfill where a waste type or mixture of wastes presents a principal threat to human health or the environment. The area should be large enough so that remediation will significantly reduce the risk posed by the overall site and small enough to be reasonably practicable for removal

and/or treatment. Hot spots will not be investigated and characterized unless some form of documentation or physical evidence (for example, aerial photography) exists to support their existence. In cases where it is not clear whether a hot spot poses a principal threat and it is practicable to excavate, at least one alternative should be developed for removal/treatment of that area. This alternative will be considered during detailed analysis of remedial action alternatives.

4.2.3.1 Excavation (Hot Spots)

Excavation of hot spots will be required prior to consolidation, treatment (except in situ treatment) or disposal offsite. Excavation of hot spots to remove contaminated soils will require the use of standard construction equipment or special equipment adapted to minimize disturbance of the deposit or secondary migration. Also, any excavations must be performed in accordance with OSHA. Typically, mechanical equipment such as backhoes, bulldozers, and front-end loaders is used for excavation. The use of scrapers and draglines usually makes it difficult to adequately control site dispersion. While the selection of specific equipment normally is based on contractor preference, the selection also depends on the water table location, the water content, and consistency and strength of the contaminated soils to be excavated. It is almost always cost-effective to excavate contaminated soil in thin, 4- to-12-inch layers to minimize the volume to be managed.

In many cases, due to landfilling practices and the weight of overlying material, drums may be crushed and empty. Isolated drums located throughout the landfill may not be identifiable nor represent a principal threat. In the event that buried, full drums, are encountered, the hazards associated with the drums must be evaluated. Evaluation may be accomplished by staging, opening, sampling and analysis followed by transport and disposal. Ambient air should be monitored continuously during drum removal activities. A drum grappler, a drum cradle or sling attached to a backhoe or crane, or a front-end loader can be used for drum removal. Drums may be opened by bung removers or drum cutters. Depending on their

condition, removed drums may need to be over-packed into salvage drums prior to transport.

Some implementation and O&M considerations concerning excavation include the following:

- Excavation of hot spots is a conventional, demonstrated technology that can be cost-effective, particularly when areas are consolidated with other landfill material prior to capping.
- Solid material above the water table can be excavated with very little secondary migration and good control of depth of cut. By using the proper excavation equipment and sediment control devices, the effect of surface runoff can be minimized.
- Waste disposal may require handling, stockpiling, and truck hauling of large volumes of material.
- Good control of depth of excavation can be difficult under water. In some cases, excavation would require the construction of impermeable barriers and site dewatering.
- In situations where excavation extends below the water table, dewatering is likely to be required. Consideration should be given to seasonal fluctuations in the groundwater table. Significant shoring and dewatering costs may be eliminated by excavating at times when the water table is low.
- Site accessibility to heavy equipment should be evaluated to determine whether track vehicles may be required.
- The distance over which excavated material must be hauled should be evaluated to determine whether separate moving equipment (such as dump trucks) is required.
- Seasonal (climate) constraints on excavation activities may affect the schedule for excavation. Depending on the

size of the area, temporary enclosures and portable heating devices may be used if excavation occurs during winter months.

- Enclosure of the excavation area may be necessary if volatile organic compound (VOC) emissions are high.
- Potential exposure to workers and nearby communities during excavation must be considered. Enclosed cabs may be necessary to minimize operator exposure.

The primary data needs for preparing an excavation plan for removal of contaminated materials include:

- Waste characteristics--Excavation is not suited for materials with a low solids content (dewatering may be required). Total suspended solids (TSS), total dissolved solids (TDS), volume-weight (percentage of moisture) analysis may be necessary to determine the solids content if contamination extends below the water table. Other data such as particle size, viscosity, and pH may also assist in material handling needs. Analysis for hazardous waste parameters (for example, TAL metals, TCL organics) and geophysical testing (for example, magnetometry or ground penetrating radar) may be warranted if the presence of buried drums is suspected.
- Water table levels (and seasonal fluctuations, if data exists)
- Volume of contaminated material
- Geologic characteristics from geologic maps and boring logs to assess difficulty of excavation
- Climate information from National Climatic Center (NCC) or local weather bureau to assess frequency of rains, seasonal variations in temperature

4.2.3.2 Consolidation

A common disposal option for outlying hot spots at municipal landfill sites is consolidation with other landfill material followed by capping. Consolidation may also be a practicable alternative for disposal of wastes in undesirable locations (for example, wetlands) or contaminated sediments. The objective of consolidation is to relocate contaminated material from outlying areas into the landfill contents to minimize the required size of a landfill cap.

Since consolidation within the area of contamination is not considered management of the material, Land Disposal Restrictions (LDR) requirements do not apply. Therefore, material can be consolidated without being treated first. In situations where contamination has spread to eroding sideslopes, contaminated soil can be excavated and consolidated within the landfill, thereby reducing the required area of the cap. Consolidated material can also be used as fill under the cap as called for by the grading plan.

Some implementation and O&M considerations concerning consolidation include the following:

- Consolidation is usually implemented in conjunction with capping, and the cap design may be influenced by the volume and nature of the material being consolidated.
- Consolidation may require handling, stockpiling, and truck hauling of large volumes of material.
- Considerations and data needs listed under excavation should also be reviewed.
- Potential exposure to workers and nearby communities during consolidation activities must be considered.

The primary data needs to evaluate consolidation are basically covered under the data needs for preparation of an excavation plan. The most important information to coordinate with the selection and design of a landfill cap will include:

- Waste characteristics of hot spot--determined during site characterization
- Volume of contaminated material

4.2.3.3 Disposal Offsite (Hot Spots)

Offsite land disposal is generally considered the least desirable alternative for remediation. However, offsite disposal may be employed if onsite treatment followed by disposal under the landfill cap is not feasible. Onsite disposal may not be feasible or practical if the waste is regulated under RCRA and must be disposed of in a RCRA landfill.

The requirements for offsite disposal of contaminated soils will be based largely on the RCRA LDRs. The LDRs may be applicable to the contaminated soils if it is determined that the soils have been contaminated by a restricted listed RCRA waste or if the contaminated soils exhibit a RCRA hazardous waste characteristic. As previously stated, LDRs do not apply if the hot spots are to be consolidated (only) under the landfill cap.

If it is determined that the contaminated soils are a RCRA waste, the LDRs may require that a specific concentration level be achieved prior to land disposal in a RCRA landfill or that a specified technology be used for treatment prior to disposal in a RCRA landfill. If a concentration is specified and the soils are below these concentrations, the soils do not have to be treated prior to offsite disposal in a RCRA landfill. It is possible that treated soils, particularly if incinerated, could be delisted and disposed of onsite or in a solid waste landfill.

If the soils are a RCRA waste, offsite land disposal must be at a permitted RCRA hazardous waste landfill that meets the requirements of RCRA Subtitle C. The design features of a RCRA hazardous waste landfill are defined in 40 CFR 264 Subpart N. The major requirements of such landfills include an impervious cap; a double liner; a leachate detection, collection, and removal system; run-on and runoff control systems; and wind dispersal controls.

In the absence of other regulations, solid waste landfills will be regulated under RCRA Subtitle D. In most cases, however, state regulations govern the design, construction, operation, and closure of solid waste landfills. Currently, in many states, the requirements for new solid waste landfills are approaching the complexity and restrictiveness of requirements for disposal of hazardous waste.

CERCLA Section 121(d)(3) and the CERCLA offsite policy contain another set of requirements that will impact the offsite disposal of CERCLA wastes. EPA's current offsite policy (OSWER Directive 9834.11, November 13, 1987ff) describes procedures that must be observed when a CERCLA response action involves offsite management of CERCLA wastes. The general requirements of the offsite policy are to be codified and expanded in a proposed rule, which will supersede the current policy when finalized (see 53 FR 48218 (November 29, 1988)). Generally, this policy requires that an offsite facility accepting the waste have no relevant violations or other environmental conditions that pose a significant threat to public health, welfare, or the environment, or otherwise affect the satisfactory operation of the facility. The purpose of this policy is to direct these wastes only to facilities determined to be environmentally sound and thus avoid having CERCLA waste contribute to present or future environmental problems. A Regional Offsite Coordinator has information on the acceptability of commercial facilities in the region to receive CERCLA wastes.

Some implementation and O&M considerations concerning offsite disposal of contaminated soils in a RCRA or hazardous waste landfill include:

- Landfilling may be the best or only disposal method for certain solid hazardous wastes.
- Based on LDRs, treatment of soils may be required prior to disposal.
- In addition to the LDRs, offsite disposal must comply with the CERCLA offsite policy.

- High volume wastes may be disposed of more economically by landfilling than by treatment, although landfilling does not reduce toxicity, mobility, or volume of wastes.
- Waste handling and landfilling technology is well developed. However, offsite disposal in a landfill cannot be considered permanent remediation of the contaminated material, and future risk and liability are associated with landfilling of wastes.

There are no specific design considerations associated with offsite disposal; however, associated technologies such as excavation and soils treatment may be employed prior to offsite disposal.

In order to evaluate the offsite disposal options, the following data should be gathered:

- Characteristics of waste to determine suitability for offsite disposal (for example, RCRA characteristic tests, moisture content, hazardous waste parameters). The potential landfill(s) that may be used for offsite disposal should be contacted to determine what analysis they require. These tests should be included in the analysis of hot spots.
- Volume of waste to be disposed offsite.

4.2.4 Hot Spots Treatment

Based on review of the remedial actions that are being conducted at municipal landfill sites on the NPL, it was found that the most often selected soils treatment technology is onsite thermal treatment (incineration). Offsite incineration is rarely chosen as an acceptable alternative because of the current lack of available capacity. Although in-situ treatment is likewise rarely used, this type of response action, particularly in-situ stabilization and in-situ vapor extraction, may warrant some consideration if the type of soil contamination is treatable by this technology. Other technologies for treatment of hot spots are, at the present time, rarely selected. This is probably because of the heterogeneous nature of landfill wastes and the

corresponding complexity associated with implementing in situ technologies at landfill sites. As with excavation, soil treatment is considered a feasible alternative only for hot spots and, when practicable, for contents of small to moderate landfills (e.g., less than 100,000 cubic yards).

4.2.4.1 Thermal Treatment (Onsite)

Thermal treatment is an appropriate method for the destruction or treatment of combustible organics in soil. Onsite thermal treatment can be conducted in a field-erected facility or mobile unit. Low temperature thermal volatilization can also be used to remove VOCs (or semivolatiles if operated at high enough temperatures) in a soil drying unit. However, this technology is rarely effective by itself because of the mixed nature of landfill waste material that includes inorganics and nonvolatile fraction of organics.

Thermal treatment exposes waste material to a high temperature for a specific period of time. When heated in the presence of sufficient oxygen for combustion (incineration), the waste is chemically transformed into innocuous substances such as carbon dioxide and water. This process also produces ash and a certain amount of oxides and acid gases, depending on the composition of the waste and the process conditions under which it is oxidized. When heated in the absence of oxygen (pyrolysis), the waste decomposes, producing a residue and a variety of vapor-phase compounds that can then be incinerated.

Analysis and characterization of the waste usually determine whether it can be treated by incineration. The analysis also provides the physical property data used in the design of process equipment.

Incineration technologies include rotary kiln, fluidized bed, multiple hearth, radiant heat, molten salt, liquid injection, and molten glass. Pyrolysis technologies include conventional pyrolytic reactors, rotary hearth pyrolyzer, ultra-high temperature reactors, and starved-air combustion. The most commonly used system has been rotary kiln incineration. It is usually desirable not to specify in the feasibility study which incineration process option will be used.

Rather a representative option, such as rotary kiln, can be presented as an example with the actual process option decision being made during design or by the contractor based on performance specifications. It should be noted that the use of performance specifications allows for a variety of both innovative and established incineration technologies to be considered.

Some implementation and O&M considerations concerning the use of thermal treatment for contaminated hot spot material include the following:

- Space requirements typically are modest but should be considered.
- Typically, efficiency of destruction is high, emissions can be effectively controlled, and destruction/treatment is immediate.
- Waste heat recovery may be possible and should be considered.
- The weight and volume of combustible waste may be reduced by more than 90 percent through thermal treatment. In some cases, incineration of solid waste (e.g., soils) may result in little or no reduction in volume; however, the solid feed will be decontaminated.
- Residues may be delistable and disposed of onsite (although exceedance of the TCLP characteristics for metals may require solidification prior to onsite disposal).
- Capital and operating costs are typically high and should be considered.
- Ash disposal may have to be at a RCRA landfill if it is classified as a hazardous waste.
- Supplemental fuel is required for startup and may be necessary to maintain combustion.
- Significant material handling, pre-processing, and post-processing may be

required (for example, for rocks, drums).

- Products of incomplete combustion (PICs) may be generated that are difficult to assess or control.

Data needed for evaluation of thermal treatment technologies and for design purposes include the following:

- Waste characterization data (For wastes with high concentrations of inorganics, thermal treatment may not be the best alternative, or other treatment technologies may be needed in conjunction with incineration. Also, physical characteristics such as large percentage of rocks and boulders may indicate that waste segregation or pretreatment is required.)
- Heat content of waste (A BTU analysis should be done to evaluate the need for auxiliary fuel.)
- Pilot testing during either the feasibility study or the predesign phase (Such testing is often required to evaluate the treatability of the contaminated soils by thermal means.)

4.2.4.2 Stabilization

Stabilization, which is used for treatment of viscous fluids, solids, and contaminated soil, is a feasible option for hot spots. To date, stabilization (or solidification) has rarely been used at municipal landfill sites. However, it appears to be potentially feasible for soils contaminated by inorganics. Stabilization has also been used for treatment of low-level-radiation-contaminated soils and for soils contaminated by low concentrations of organics, whereby leaching of organics is reduced but not eliminated.

Stabilization using an onsite batch process consists of excavation of wastes, onsite mixing with reagents in a batch plant (for example, a cement kiln) and finally, replacement in the landfill area. Use of a batch process will trigger LDRs; treated waste will either have to be disposed of in an offsite RCRA landfill or may be delisted and disposed of

onsite or in an offsite solid waste landfill. In situ stabilization refers to processes where stabilizing reagents (pozzolanic material) are added in place to improve physical characteristics of waste by rendering wastes nonhazardous and nonleachable. Reagents are mixed with the contaminated waste using standard earth-moving equipment such as backhoes, drag lines, bucket loaders, or by large-diameter augers. In situ stabilization offers the advantage that soils can be treated in place. However, greater quality control, such as assurance of complete mixing of reagents, can be achieved using a batch plant.

Pretreatment such as screening, segregation, and removal of larger objects such as drums and debris may be necessary. In situ stabilization is typically accomplished in relatively shallow lifts, commonly about 2 feet deep, since large quantities of materials are moved as a mass to accomplish mixing. Depth of contamination is also generally limited to approximately 12 feet, although this technology can potentially be used for deeper contamination by progressively removing solidified wastes while increasing working depth. For deeper sites, excavation and addition of reagents using a batch plant may be appropriate.

The ratio and composition of reagents vary depending on the waste. A wide range of common pozzolanic stabilizing reagents can be selected, depending on what is locally available, and reagents can be proportioned on the basis of untreated waste characteristics. A typical formulation of stabilizing agents might be 30 percent fly ash, 30 percent kiln dust, 20 percent portland cement, and 20 percent hydrated lime. Most inorganic hazardous sludges can be mixed directly with pozzolanic materials to form a hardened soil-like material. Extraneous materials such as asbestos, sulfides, and solid plastics may increase the strength of the treated material. Impurities such as organic materials, silt, clay, lignite, fine dust, sulfates, or soluble metal salts may retard or inhibit setting and curing, may reduce strength, or may cause swelling and splitting of the solidified mass. Typically, wastes containing high levels of organic (e.g., 10 to 20 percent) constituents require some form of pretreatment before solidification with pozzolanic materials. Treatability

studies must be performed to determine if the contaminated waste/soil is amenable to stabilization.

Because of the nature of stabilization, the final volume of treated waste typically is 10 to 30 percent greater than the original volume of waste. However, volume increases of 50 to 100 percent are possible, depending on waste and site characteristics.

Some implementation and O&M considerations concerning stabilization include the following:

- A wide variety of inexpensive reagents is available.
- The technology is applicable to many different waste materials.
- Waste remains onsite (this may or may not be an advantage, depending on site-specific circumstances).
- Use of a batch process will trigger LDRs.
- There may be a significant increase in volume that should be considered.
- Difficulty may arise in verifying sufficient mixing and completion of the process.
- Stabilization may not be applicable to wastes containing moderate to high concentrations of organics.
- It may be difficult to control odors, VOCs, or dust during processing.
- Wastes containing drums, construction debris, etc., may require some pretreatment.
- Long-term monitoring will be necessary to verify whether contaminants are leaching to the groundwater.
- Evaluating the long term effectiveness of stabilization should be included in the 5-year review.

Data that should be gathered for design and implementation of stabilization include:

- Waste characterization (Inorganic and organic hazardous constituents, and a measure of the total organics present such as total organic carbon [TOC]). Treatability studies should also be performed during the FS to evaluate if the waste is amenable to stabilization, particularly when organics are present. Treatability tests will need to be conducted during design to optimize the formulation of stabilization agents.
- Depth of waste to be stabilized (Depth should be less than 12 feet for in situ stabilization.)
- Total bulk unit weight of material (Soils will typically be between 80 to 110 lbs/ft³; liquids and sludges typically range between 63 to 80 lbs/ft³.)

4.2.5 Innovative Treatment Technologies

4.2.5.1 Description of Technologies

The focus of this document has been on traditional, previously used, and proven remedial technologies. This section is intended to address some innovative treatment technologies that may be appropriate for remedial actions at municipal landfill sites. It is important that the evaluation of alternatives for municipal landfill sites not be limited to conventional technologies, particularly in situations where more effective or less costly treatment can be achieved by using innovative remedial technologies.

The following two technologies are presented as innovative technologies that may be viable for hot spots at municipal landfill sites:

- Vapor extraction
- In situ bioremediation

Other innovative technologies may also be viable and should be considered if they are appropriate to site characteristics.

Soil Vapor Extraction. Soil vapor extraction (SVE) is an in situ process used to remove VOCs from soil. This technology may be suitable for treating hot spots contaminated with VOCs; removal of VOCs can significantly reduce the mobility of the other contaminants present, such as inorganics or semivolatile organics. SVE consists of a network of wells with perforated well screens. These wells are packed with gravel and sealed at the top with bentonite to prevent short circuiting. The extraction wells are connected to the suction side of a vacuum extraction unit through a surface collection manifold. The vacuum extraction unit induces a flow of air through the subsurface into the extraction wells. The vacuum not only draws vapors from the unsaturated zone, but it also decreases the pressure in soil voids, thereby causing the release of additional volatile organic compounds (VOCs). The extracted gas flows through the surface collection manifold and is either vented to the atmosphere, connected to a vapor-phase carbon adsorption system, or flared, depending on the nature and extent of VOC contamination. Although SVE is considered to be an innovative technology, many full-scale applications have already been installed and are currently operating or have already achieved performance objectives.

Standard procedures that exist for installing landfill gas recovery wells in municipal landfills should be applied to the installation of SVE wells. The presence of landfill gas in municipal landfills requires that special health and safety precautions be taken. The presence of landfill gas may also require modified VOC control systems. SVE can be “shortcircuited” by debris and noncontinuous lifts of material. More extraction wells installed closer together are necessary to ensure sufficient treatment. One or more wells in each lift may be necessary.

SVE treatment may be particularly cost-effective for municipal landfills that will require landfill gas control. Once SVE treatment is completed, the wells can be used to collect or vent landfill gas (see Section 4.4).

In Situ Bioremediation. In situ biodegradation is the process of enhancing microbial action to remediate subsurface contaminants that are

adsorbed to soil particles or dissolved in the water phase. This technology is designed to biodegrade chlorinated and non-chlorinated organic contaminants by employing aerobic bacteria that use the contaminants as their carbon source. This technology could be applied to remediate contaminated soil and groundwater without excavating overlying soils. The technology uses special strains of cultured bacteria and naturally occurring microorganisms to achieve biodegradation. The end result is carbon dioxide, water, and bacterial biomass.

The most common in situ biodegradation method couples the stimulation of the activity of native microorganisms through oxygen and inorganic nutrient addition with the more conventional “groundwater pump and treat” approach. This approach is generally the most demonstrated and most appropriate application or in situ biodegradation.

Conventional pump and treat cleanup is a passive approach that largely relies on the partitioning of adsorbed contaminants into the water phase. This partitioning will be the rate limiting step in the removal process, potentially requiring an extended period of time to completely remove the adsorbed contaminant from the soil. In situ biodegradation (i.e., by adding nutrients to groundwater) provides a more direct attack on the adsorbed contaminant phase. This direct attack may significantly reduce the amount of time required for the remediation of the adsorbed contaminants. Stimulating subsurface microbial activity can also increase the rate at which contaminants are flushed from the subsurface in a pump and treat system.

4.2.6 References

Some of the more common references on remedial technologies for soils/landfill contents are listed below.

Containment:

Ghassemi, M. *Assessment of Technology for Constructing and Installing Cover and Bottom Liner Systems for Hazardous Waste Facilities: Vol. I.* Ghassemi EPA Contract No. 68-02-

3174. U.S. Environmental Protection Agency. May 1983.

Kmet, P., K.J. Quinn, and C. Slavik. *Analysis of Design Parameters Affecting the Collection Efficiency of Clay Lined Landfills*. University of Wisconsin. September 1981.

Lutton, R.J. et al. *Design and Construction of Covers for Solid Waste Landfill*. 600-2-79-165. U.S. Environmental Protection Agency. August 1979.

Lutton, R.J. *Evaluating Cover Systems for Solid and Hazardous Waste*. SW867. U.S. Environmental Protection Agency. 1982.

Morrison, W.R. and L.R. Simmons. *Chemical and Vegetative Stabilization of Soil: Laboratory and Field Investigations of New Materials and Methods for Soil Stabilization and Erosion Control*. Bureau of Reclamation Report No. 7613. U.S. Bureau of Reclamation. 1977.

U.S. Environmental Protection Agency. *RCRA Guidance Document Landfill Design, Liner Systems and Final Cover*. (Draft). July 1982.

U.S. Environmental Protection Agency. *Lining of Waste Impoundment and Disposal Facilities*. SW870. 1983.

U.S. Environmental Protection Agency. *Handbook of Remedial Action of Waste Disposal Sites (Revised)*. EPA/625/6-85/006. October 1985.

U.S. Environmental Protection Agency. *A Compendium of Technologies Used in the Treatment of Hazardous Wastes*. EPA/625/8-87/014. September 1987.

U.S. Environmental Protection Agency. *Final Covers on Hazardous Waste Landfills and Surface Impoundments*. EPA/530-SW-89-047. July 1989.

U.S. Environmental Protection Agency. *Covers for Uncontrolled Hazardous Waste Sites*. EPA/540/2085-002.

U.S. Environmental Protection Agency.

Procedures for Modeling Flow Through Clay Liners to Determine Required Liner Thickness. EPA/530-SW-84-001.

U.S. Environmental Protection Agency. *Technical Guidance Document: Final Covers on Hazardous Waste Landfills and Surface Impoundments*, EPA/530-SW-89-047. July 1989.

Warner, R.C. et al. *Demonstration and Evaluation of the Hydrologic Effectiveness of a Three Layer Landfill Surface Cover Under Stable and Subsidence Conditions*. Phase I, Final Project Report. U.S. Environmental Protection Agency.

Removal/Disposal:

U.S. Army. *Dewatering and Groundwater Control for Deep Excavations*, Technical Manual No. 5-818-5. Prepared by the Army Engineers Waterways Experiment Station. 1971.

U.S. Environmental Protection Agency. *Handbook of Remedial Action of Waste Disposal Sites (Revised)*. EPA/625/6-85/006. October 1985.

U.S. Environmental Protection Agency. *Technology Briefs, Data Requirements for Selecting Remedial Action Technology*. EPA/600/2-87/001. January 1987.

Soil Treatment:

U.S. Environmental Protection Agency. *Handbook of Remedial Action of Waste Disposal Sites (Revised)*. EPA/625/6-85/006. October 1985.

U.S. Environmental Protection Agency. *Systems to Accelerate In-Situ Stabilization of Waste Deposits*. EPA/540/2-86/002. September 1986.

U.S. Environmental Protection Agency. *Technology Briefs, Data Requirements for Selecting Remedial Action Technology*. EPA/600/2-87/001. January 1987.

Innovative Remedial Technologies:

Michaels, P.A., and M.K. Stinson. *Technology Evaluation Report, Vacuum Extraction System*.

Groveland, Massachusetts. Risk Reduction Engineering Lab., ORD. EA68-03-3255. 1989.

U.S. Environmental Protection Agency. *Handbook of Remedial Action at Waste Disposal Sites (Revised)*. EPA/625/6-85/006. October 1985.

U.S. Environmental Protection Agency. *Technology Briefs; Data Requirements for Selecting Remedial Action Technology*. EPA/600/2-87/001. January 1987.

U.S. Environmental Protection Agency. *Technology Screening Guide for Treatment of CERCLA Soils and Sludges*. EPA/540/2-88/004. September 1988.

U.S. Environmental Protection Agency. *Terra Vac In Situ Vacuum Extraction System, Applications Analysis Report*. EPA/540/A5-89/003. July 1989.

U.S. Environmental Protection Agency. *The Superfund Innovative Technology Evaluation Program: Technology Profiles*. EPA/540/5-89/013. November 1989.

U.S. Environmental Protection Agency. *Handbook on In Situ Treatment of Hazardous Waste-Contaminated Soils*. EPA/540/2-90/002. January 1990.

U.S. Environmental Protection Agency. *International Waste Technologies/Geo Con In Situ Stabilization/Solidification, Applications Analysis Report*. EPA/540/A5-89/004, August 1990.

U.S. Environmental Protection Agency. *Experience in Incineration Applicable to Superfund Site Remediation*. EPA/625/9-88/008.

U.S. Environmental Protection Agency. *High Temperature Treatment for CERCLA Waste: Evaluation of Onsite and Offsite Systems*. EPA/540/4-89/006.

U.S. Environmental Protection Agency. *Stabilization/Solidification of CERCLA and RCRA Wastes*. EPA/625/6-89/022.

U.S. Environmental Protection Agency. *State of Technology Review: Soil Vapor Extraction Systems*. EPA/600/2-89/024.

4.3 Leachate

4.3.1 Collection of Leachate

Leachate from landfills is a product of natural biodegradation, infiltration, and groundwater migrating through the waste. Landfill leachate is typically high in biochemical oxygen demand (BOD), chemical oxygen demand (COD), and heavy metals. The function of a leachate collection system is to minimize or eliminate the migration of leachate away from the solid waste unit. This system is typically used to control seepage along the sideslopes of a landfill and to prevent discharges to surface and groundwater systems. Leachate collection systems commonly used are subsurface drains and vertical extraction wells.

4.3.1.1 Subsurface Drains

Subsurface drains consist of underground, gravel-filled trenches generally equipped with tile or perforated pipe for greater hydraulic efficiency. They are used to intercept and channel leachate to a sump, wet well, or appropriate surface discharge before it can infiltrate to the main aquifer system. Drains, usually installed at the edge of the waste fill, can also be used to collect contaminated groundwater and transport it to a central area for treatment or proper disposal. Typically, subsurface drains are installed at the perimeter of the landfill, although in landfills where the thickness of fill is less than approximately 15 feet, it may be appropriate to consider installation within the landfill. Depth of waste as well as hazards associated with excavating landfill material usually prevents installation of drains within the landfill.

4.3.1.2 Vertical Extraction Wells

Vertical extraction wells are wells drilled in the waste and screened in a highly permeable water bearing zone. This zone may be perched above the surrounding water table or may be in the groundwater. The intent is to collect highly

contaminated leachate or leachate/groundwater mix. The wells, which typically run to the base of the landfill, are fitted with a pump to extract leachate and create a negative pressure zone to promote leachate flow towards the wells. It should be noted that without the proper precautions, placing wells into the landfill contents may create health and safety risks. Perimeter wells may also be installed at the landfill boundary as a source control measure to control offsite migration of leachate and contaminated groundwater. Maintenance of the wells is essential because the permeable layer is prone to fouling due to biological growth or precipitation of metal hydroxides.

Some implementation and O&M considerations concerning leachate collection include the following:

- A properly designed leachate collection system should provide a reduction in the potential for migration of leachate to surface water and groundwater.
- Distribution and discontinuities of liquids within the landfill will affect the placement and number of wells required.
- Hydraulic head will vary throughout the landfill.
- Extraction systems will require ongoing maintenance to maintain effectiveness.
- Drilling conditions must be considered.
- Creating a low-pressure zone may attract water in the landfill.
- Leachate collection is typically cost-effective compared to recovering dispersed contaminants (that is, extraction and treatment of offsite contaminated groundwater plume).
- A leachate collection system may result in an increase in landfill settlement as a result of leachate extraction.
- An effective collection system generally will require a thorough characterization

of the hydrogeology of the site before design or installation of the system.

- Consideration should be given to possible health and safety risks, difficulty in drilling and installation conditions in landfill materials, and resultant high costs (drilling within the landfill may require at least Level B health and safety protection).

The primary data needed for designing a leachate collection system include:

- Topographic characteristics of the site (for example, slopes, drainage divides)
- Site soil characteristics (for example, permeability, grain size distribution)
- Climatological characteristics (for example, precipitation, temperature)
- Hydrogeologic characteristics (for example, depth to groundwater, groundwater flow direction and velocity)
- Waste characteristics (for example, composition, moisture content, age)

4.3.2 Treatment of Leachate

Either onsite or offsite treatment of leachate may be feasible options for municipal landfill sites. Leachate from municipal landfill sites may have high concentrations of organic matter (measured in terms of BOD and COD), and high concentrations of inorganics. Leachate quality varies from site to site, and will also vary over time. For example, BOD concentrations may decrease over time. Once the constituents and associated concentrations are known for the leachate, appropriate treatment technologies can be selected.

Typical concentration ranges for some contaminants that leach from municipal landfills are listed in Table 3-2 of this document. The large ranges may be due in part to analysis of leachate that has been diluted by groundwater. Additional information on leachate composition and contaminant concentrations in leachate can be found in *Characterization of MWC Ashes and*

Leachates from MSW Landfills, Monofills and Co-Disposal Sites (EPA, 1987f).

Leachate generally is treated by conventional means such as biological treatment, physical treatment, or chemical treatment. The chemical characteristics of the leachate must be determined in order to design an onsite treatment system. This chemical analysis includes:

- Quantifying the constituents in the leachate (organics and inorganics), especially the compounds to be removed
- Determining the variability of leachate characteristics
- Measuring BOD, COD, and TOC (gross indicators of organic loading for biological treatment and granular activated carbon [GAC])
- Measuring other conventional parameters for leachate such as total dissolved solids (TDS), chlorine, alkalinity, nitrate, nitrite, ammonia, total phosphorous, and sulfide
- Measuring pH (effects the efficiency of biological treatment and reagent requirements of metals precipitation)
- Determining influent flow to the treatment systems (and anticipated variability in flow such as from seasonal variation in leachate production)
- Measuring total suspended solids (TSS) in the leachate (high solids content [for example, >50 ppm] may require pretreatment before carbon adsorption)
- Measuring oil and grease in the leachate (high concentrations [for example, >10 ppm], may require pretreatment)
- Conducting treatability during predesign, as required, to optimize the treatment system

4.3.2.1 Onsite Treatment

The degree of treatment depends to a great extent on the strength of the leachate and whether the effluent is to be discharged directly to surface water or to a publicly owned treatment works (POTW). The most common technologies used at municipal landfill sites to treat leachate include biological treatment for removal of biodegradable organics, physical treatment such as air stripping and carbon adsorption for VOC removal, and chemical treatment, such as metals precipitation for removal of inorganics. Treated leachate could be discharged onsite depending on the extent of treatment. Onsite discharge can be done by groundwater aquifer reinjection or by discharge to surface water. Groundwater aquifer reinjection depends on state groundwater standards in the area where the site is located. Discharge to surface water will have to comply to NPDES Permit requirements.

Chemical Treatment. In chemical treatment, hazardous constituents are altered by chemical reactions. During the process, hazardous compounds may be destroyed or altered; the resultant products may still be hazardous but transformed to a more convenient form for further processing. The most common chemical treatment for landfill leachate is precipitation of heavy metals. Precipitation will remove soluble heavy metals from leachate by forming insoluble metal hydroxides, sulfides, or carbonates. Heavy metals typically removed by precipitation include arsenic, cadmium, chromium, copper, lead, mercury, nickel, and zinc. Metals are often removed to either meet NPDES permit limits or as pretreatment to reduce metals toxicity for biological treatment. Chemical precipitation involves alteration of the ionic equilibrium to convert soluble metal ions to insoluble precipitates. These precipitates are then removed by solids separation processes such as sedimentation and filtration.

Precipitation reactions for leachate treatment purposes are usually induced by one or more of the following steps:

- Add a substance that reacts directly with the compound in solution to form a less soluble compound.
- Add a substance that shifts the solubility equilibrium to a point that no longer favors the continued solubility of the compound. For instance, pH affects the equilibrium concentration of ionic species. This is particularly true when the respective solid phase is a hydroxide or carbonate compound.
- Change the temperature of a saturated or nearly saturated solution to decrease solubility.

Most precipitation reactions are carried out by adding appropriate chemicals and mixing. Common additives include lime, soda ash, and caustic. The main liquid stream's pH may need to be adjusted after removal of the solid precipitates.

Biological Treatment. Biological means are used in treating leachate contaminated primarily by biodegradable organic compounds. Biological treatment is especially effective in treating landfill leachate that typically has high levels of BOD and COD (e.g., 0-750,000 mg/l).

In biological treatment, wastewater is contacted by a culture of microorganisms either suspended in the wastewater or attached to a solid medium. The organic compounds in the wastewater are metabolized by the organisms as a food and energy source. Organics are thus removed from solution and biomass and metabolic waste gases such as carbon dioxide and methane are produced. Biological treatment systems are configured as fixed growth, suspended growth, or a combination of both. They can be designed to treat hundreds of millions of gallons per day (MGD) or as little as 1 gallon per minute (0.0014 MGD).

Biological treatment processes can be classified as aerobic or anaerobic. Aerobic treatment systems require oxygen, either in air or in pure form, to meet the metabolic needs of the micro-organisms. Aerobic treatment systems are the most frequently used form of biological treatment. These systems

consist of a reactor, where the waste stream is brought in contact with a culture of organisms, and usually a clarifier or other solids-separation device where organisms suspended in solution are removed by sedimentation.

Anaerobic treatment systems are used most often for treating high-strength wastes. These systems are often followed by an aerobic treatment system for additional organics removal. Compared to aerobic systems, anaerobic treatment systems produce less biomass per pound of BOD removed. In addition, anaerobic treatment produces methane of sufficiently high concentration to be used in some cases for energy recovery. Anaerobic digesters are also frequently used in the treatment of sludge produced in aerobic treatment. In this process, the sludge is reduced in volume and methane gas is produced as a by-product.

Physical Treatment. Two types of physical treatment technologies most commonly used to treat leachate are air stripping and granular activated carbon (GAC) for the removal of organics. Other conventional physical treatment technologies such as sedimentation and filtration may also have to be incorporated as part of the overall treatment system.

Activated carbon is usually applied after conventional treatment as a polishing operation for removal of trace concentrations of residual organics and/or heavy metals. It is also used for the reduction of COD and BOD, for the removal of toxic or refractory organics, and for the removal and recovery of certain organics and inorganics from aqueous waste. Applications involving organic solutes are most effective when the solutes have a high molecular weight, low water solubility, low polarity, and a low degree of ionization. Many organic compounds such as phenolics, aromatics, and chlorinated hydrocarbons are readily adsorbed on the surface of activated carbon. In addition, certain heavy metals such as cadmium, chromium, copper, nickel, lead, and zinc can be removed from water with carbon, although this technology is not widely used for metals removal.

Most organic and some inorganic solutes are absorbed as the leachate stream is passed

through the carbon, usually in packed beds. When the carbon reaches its maximum capacity for adsorption, or when effluent concentrations are unacceptable, the spent carbon is replaced by fresh carbon. The carbon may be regenerated offsite whereby the adsorbed contaminants are incinerated, or the carbon may be disposed of in a RCRA landfill if regeneration is not cost-effective.

Contacting methods for granular carbon include adsorbers in parallel, adsorbers in series, moving-bed, and upflow-expanded beds. Carbon loadings can approach 1 pound of COD removal per pound of carbon. The concentration of COD in the influent can typically be as high as 1 to 5 percent. Suspended solids in the influent should generally be less than 50 ppm to minimize backwash requirements. Actual carbon usage rates are determined during pilot testing.

Air stripping is used in municipal landfill applications for the removal of VOCs from leachate or groundwater. When leachate containing a volatile compound is brought to equilibrium conditions with air, some portion of the volatile compound transfers from the water to the air. The resulting concentrations of the volatile compound in the air and in the water are a function of the beginning concentration in the water, the temperature, the pressure, and the degree of volatility of the compound. The volatility of the compound--that is, its tendency to leave the water and enter the air--is expressed by Henry's law constant for the particular compound. The Henry's law constant is the ratio of the concentration of the compound in the air to its concentration in water at equilibrium conditions.

Leachate contaminated with a volatile compound is fed into the top of a tower while a large air stream is forced into the bottom. The tower is usually filled with a packing medium that provides a large surface area for contact between the air and leachate. The air exits the top of the tower with the volatile compound. The leachate is collected at the bottom of the tower and is either pumped to another process area for further treatment or discharged. It should be noted that leachate may foul the packing medium and reduce the effectiveness of air

stripping.

If sufficiently low concentrations are involved, the air can be discharged to the atmosphere. Otherwise, air pollution control devices such as vapor-phase carbon may be needed. State air pollution regulations must be followed for emission controls.

Computerized mathematical models are available to estimate the effectiveness of air stripping for removing many organic compounds. However, critical operating parameters should be determined experimentally through pilot studies.

4.3.2.2 Offsite Treatment

Direct discharge to a POTW may be appropriate for leachate streams containing concentrations of contaminants that are amenable to treatment provided by the POTW. More often, pretreatment may be required before discharge to the POTW. Major considerations include the constituents of the leachate and their concentrations, the type of treatment used by the POTW, the remaining treatment capacity of the POTW, the volume of leachate to be disposed of, and the expected duration of the discharge. A high rate of flow for an extended time may require a capital expenditure to increase the capacity of the treatment works. Early contact with the POTW during the feasibility study process is important to determine the acceptability of the leachate for treatment at the POTW.

Treatment to reduce the concentrations of organics and metals can be expected at most POTWs. However, the NPDES permit for the POTW may have metals limitations that will preclude the treatment of leachate. The removal efficiency depends on the type and concentration of contaminants. Removal of organics and metals will be primarily from stripping in aeration basins, adsorption onto biological floc, and biological degradation. *Fate of Priority Pollutants in Publicly Owned Treatment Works* (U.S. EPA, 1982c) is a good source for information on treatability and on the applicability of different treatments for a particular waste stream. The need for treatability testing

or pretreatment of the waste stream must be determined on the basis of the probable effect of the contaminants on the POTW.

Treatment processes typically employed at POTWs include:

- Anaerobic processes—Including rotating biological contactors, oxidation ditches, activated sludge reactors, and trickling filters
- Aerobic processes—Including anaerobic contact reactors, anaerobic filters, fluidized bed systems, and various fixed-film systems
- Physical/chemical processes—Including dissolved-gas flotation, chemical coagulation, sedimentation, and filtration

Special considerations for discharge to a POTW include the proximity of the nearest POTW sanitary sewer sufficient to handle the flow, pretreatment requirements, and the potential health risk to POTW employees of treating wastes from CERCLA sites. Construction of gravity main or force mains to transport the discharge to the POTW collection system may be cost effective compared to onsite treatment. Typically it is cost effective to transport only low flow rates (for example, less than 2 gpm) via trucks to the POTW.

If the leachate is to be trucked offsite for treatment, and it is classified as a RCRA hazardous waste, a RCRA Part B permit would be required by the POTW to accept the leachate. In this situation, another offsite option would be to treat the leachate at a RCRA treatment, storage, and disposal facility (TSDF). There are several RCRA TSDF in various parts of the country that treat leachate. If the leachate is discharged to the sewer system (that is, piped to the POTW) the POTW is exempt from RCRA as outlined in 40 CFR 261.4(a)(1)(ii).

A discharge to a POTW is generally considered on offsite activity, even if CERCLA waste is discharged to a sewer located onsite. Therefore, the offsite policy and proposed regulations would generally apply to a discharge of CERCLA waste

to a POTW (see Section 4.2.3.3).

Some implementation and O&M considerations concerning offsite treatment include the following:

- The possible elimination of potentially strict limits for discharging to surface water or groundwater
- The acceptability at sites with sensitive public relations issues
- The limited capacity of a POTW to handle the leachate volume and contaminant loading
- The possible tendency of the POTW permitting authority to set stringent discharge standards because there is no categorical standard for CERCLA operations and because of public fear or mistrust of “hazardous waste” (Frequently, discussions on the acceptability of the discharge and discharge standards will extend well into the predesign and design phases of Superfund sites.)
- The liability of a discharger if the discharge causes the POTW to violate its NPDES permit, or if sludge from the POTW fails toxicity criteria or other standards (Some treatability testing at the POTW may be required to determine whether pass-through of leachate contaminants is likely.)
- Problems at sites with leachate of variable quality
- User fees usually imposed by POTWs receiving discharge
- The partial removal of many organics by adsorption on the biomass (Land application of the sludge by the POTW may reintroduce contaminants to the environment and should be evaluated.)
- Need to contact the POTW to determine if overflows or bypasses occur

during wet weather in the sewer to be used (If so, then precautions such as temporary storage of leachate during wet weather may be necessary.)

- Classification as a RCRA waste of leachate that is trucked offsite (RCRA waste will have to be treated at a RCRA TSDf instead of at a POTW.)

Data on leachate characteristics, which may include parameters such as COD, BOD, pH, TSS, TOC, TDS, as well as hazardous constituents such as inorganics (metals, cyanide), volatile organics, and semivolatile organics will be required by the POTW to assess whether it can accept the waste stream. Treatability testing will be necessary to evaluate the effects of the leachate on the POTW system as well as on removal capabilities.

4.3.3 References

Additional references on remedial technologies for leachate are listed below.

Collection:

U.S. Environmental Protection Agency. *RCRA Guidance Document Landfill Design, Liner Systems and Final Cover*. (Draft). July 1982.

U.S. Environmental Protection Agency. *Lining of Waste Impoundment and Disposal Facilities*. SW870. 1983.

U.S. Environmental Protection Agency. *Handbook of Remedial Action of Waste Disposal Sites (Revised)*. EPA/625/6-85/006. October 1985.

U.S. Environmental Protection Agency. *Leachate Plume Management*. EPA/540/2-85/004. November 1985.

U.S. Environmental Protection Agency. *Technology Briefs, Data Requirements for Selecting Remedial Action Technology*. EPA/600/2-87/001. January 1987.

U.S. Environmental Protection Agency. *Guidance on Remedial Actions for Contaminated Groundwater at Superfund Sites*. EPA/540/6-88/003. December 1988.

Treatment:

Cheremisinoff, P. N., and Ellerbusch, F. *Carbon Adsorption Handbook*. Ann Arbor Science, Ann Arbor, MI. 1980.

Clark, Viessman, and Hammer. *Water Supply and Pollution Control*. IEP-Dun-Donnell. New York. 1977.

Metcalf & Eddy, Inc., revised by Tchobanoglous. *Wastewater Engineering: Treatment, Disposal, Reuse*. 2nd Ed. McGraw-Hill. New York, New York. 1979.

Treybal, R. *Mass Transfer Operations*. 3rd Ed. McGraw-Hill. 1983.

U.S. Environmental Protection Agency. *Fate of Priority Pollutants in Publicly Owned Treatment Works*. EPA/440/1-82/303. 1982.

U.S. Environmental Protection Agency. *Permit Guidance Manual on Hazardous Waste Land Treatment Demonstrations, Draft*. EPA 530-SW-84-015. December 1984.

U.S. Environmental Protection Agency. *Handbook of Remedial Action of Waste Disposal Sites (Revised)*. EPA/625/6-85/006. October 1985.

U.S. Environmental Protection Agency. *Guide for Identifying Cleanup Alternatives at Hazardous Waste Sites and Spills*. EPA/600/3-83/063. December 1985.

U.S. Environmental Protection Agency. *Technology Briefs, Data Requirements for Selecting Remedial Action Technology*. EPA/600/2-87/001. January 1987.

U.S. Environmental Protection Agency. *Characterization of MWC Ashes and Leachates from MSW Landfills and Co-Disposal Sites*. EPA/530/SW-87/028A. October 1987.

U.S. Environmental Protection Agency. *Guidance on Remedial Actions for Contaminated Groundwater at Superfund Sites*. EPA/540/6-88/003. December 1988.

U.S. Environmental Protection Agency. *CERCLA Site Discharges to POTWs*. EPA/540/6-90/005. August 1990.

4.4 Landfill Gas

4.4.1 Collection of Landfill Gas

Landfill gas (LFG) is produced naturally when organic material from a landfill decomposes. LFG collection should be considered in the following situations:

- When homes and buildings are (or are planned to be) adjacent or close to the landfill
- When wastes have a high organic content
- When future use of the site may involve allowing access to the public (for example, as a park)
- When emissions pose an unacceptable health risk
- When the landfill produces excessive odors
- When gas pressure building under the cap can damage it and/or curb vegetative growth on the cap
- When state ARARs require treatment of the LFG

A proper landfill cover decreases odors and vertical migration of gas. However, it increases lateral gas migration and with it the potential of entrapping explosive methane gas in nearby structures. The lateral movement of LFG can be intercepted by either permeable or impermeable systems. Permeable interception systems capture gas that is moving laterally and provide conduits for the gas to escape to the surface. These systems typically consist of horizontal trenches and/or pipes and vertical wells. Impermeable interception systems block the flow of the gas and also provide conduits to the surface. Typical components of impermeable systems are barriers made of clays and synthetic

liners.

Most often they are used in conjunction with trenches.

Design considerations for LFG collection include:

- Volume and type of wastes present
- Depth of fill
- Subsurface geology of the site
- Field measurements
 - Waste constituents
 - LFG concentrations
 - Moisture content of waste
 - Preferential flow paths
 - Soil permeabilities

LFG collection systems are divided into two main groups: passive systems and active systems.

4.4.1.1 Passive Systems

Passive LFG control systems alter subsurface gas flow paths without using mechanical components. Generally, they direct subsurface flow to points of controlled release through the use of high-permeability systems. Flow paths to outside areas are blocked through the use of low-permeability barriers. High-permeability systems usually consist of trenches or wells excavated at the boundary of the landfill and backfilled with permeable material (for example, gravel, crushed stone, etc.) to create a preferential gas flow path. Low-permeability barriers typically consist of clay-lined or synthetic-lined (HDPE, PVC, Hypalon, etc.) trenches or walls. Passive systems are not used to recover landfill gas, instead their only use is to control the release of landfill gas to the atmosphere. Typical passive systems are pipe vents and trench vents.

Pipe Vents. Pipe vents are used for venting LFG at points where it is collecting and building up pressure. They are often used with flares that burn the gas at the point of release. Pipe vents typically are simple, inexpensive, and effective at reducing localized LFG pressure.

However, some considerations concerning pipe vents include the following:

- They potentially will have a small zone of influence (less than 5 feet in compacted refuse).
- They may result in increased odor problems (due to LFG release to the atmosphere).
- There may be a potential danger of explosion at the point of release, which should be considered and evaluated.

Trench Vents. Trench vents usually consist of gravel trenches surrounding the waste site. They form a path of least resistance through which gases migrate upward to the atmosphere. A barrier system can be added to the outside of the trench to increase its effectiveness in controlling LFG.

Trench vents typically are more effective than pipe vents for containment and control. They require little maintenance, and they are relatively inexpensive. If there are houses nearby, trench vents, possibly in conjunction with pipe vents, should be considered to minimize the potential for lateral migration of LFG. Gas migrating laterally into basements can create toxic or explosive conditions. Some considerations concerning trench vents include the following:

- Runoff can infiltrate and clog open vents.
- Gases may migrate under the trench if it is not constructed to a sufficient depth or keyed into an impervious layer.
- There is potential for failure of the barrier system below a 15- to 20-foot depth.
- Odor problems are possible.

The most important data needed for designing a passive gas control system are:

- Topographic characteristics of the site (for example, contour elevation map)
- Soil characteristics (for example, permeability, grain-size distribution, soil content)
- Geologic characteristics (for example, type of subsurface strata, pH, temperature, depth of bedrock)
- Climatologic characteristics (for example, precipitation, temperature)
- Hydrogeologic characteristics (for example, depth to groundwater inside and outside the landfill)
- Waste characteristics (for example, composition, biodegradables and organics content, moisture content)

4.4.1.2 Active Systems

Active systems to control LFG restrict subsurface migration of gases. The systems use mechanical means to alter pressure gradients and redirect subsurface gas flow. Major system components generally include gas extraction wells, gas collection headers, vacuum blowers or compressors, and gas treatment or use systems. Active systems are typically used in landfills where severe odor problems exist, they are also used to prevent LFG from migrating to and endangering nearby structures. LFG recovery and sale or use as a source of energy are only possible with active systems.

Gas extraction wells are drilled to the seasonal low groundwater level or to the base of the landfill. Typically, a perforated pipe is set in the well with permeable material surrounding the pipe. At the top of the well, the pipe is nonperforated and the surrounding area is sealed with concrete or clay. A gas collection header is connected to the top of the pipe and to several other extraction wells spaced at regular intervals. Vacuum blowers or compressors, connected to the headers, are used to create a negative pressure area, which causes gases to be drawn up from the extraction wells. Then gases are treated and either released to

the atmosphere or recovered and used to generate energy.

The most common active system is an onsite extraction well system. It consists of a series of extraction wells in the landfill, typically 100 to 300 feet apart. The applied extraction vacuum withdraws LFG in both the horizontal and vertical directions. Vacuum blowers extract the LFG from the wells, and push the collected LFG through a free vent or waste-gas burner. Enclosed flares have proven effective in destroying the combustible components of the LFG and thereby eliminating odor problems.

Some implementation and O&M considerations concerning active gas control systems include the following:

- Active gas control systems can provide effective LFG control with an area of influence larger than that of passive systems (depending on the design).
- Odors and reactive organic gas emissions are reduced as compared to passive systems.
- There is potential for use of LFG.
- The expense is greater compared to passive systems because of the complicated design and mechanical equipment required.
- Regular O&M is required for optimal results (depends on the design and volume generated). For example, collection systems may become clogged with biological growth or sediments.
- Condensate handling is required (possibly classified as a RCRA hazardous waste).
- Modifications after startup may be necessary because of the variability of solid waste and soils placed at the site (affects gas production).
- Landfill settlement may cause collection piping to bend.

The typical data needed for designing an active system include:

- Topographic characteristics of the site (for example, contour elevations map)
- Soil characteristics (for example, permeability, moisture content, grain size distribution)
- Geologic characteristics (for example, type of subsurface strata, pH, temperature, depth of bedrock)
- Hydrogeologic characteristics (for example, depth to groundwater)
- Waste characteristics (for example, composition, moisture content, percent compaction)
- Depth, volume, and approximate settlement rate of wastes

4.4.2 Treatment of Landfill Gas

4.4.2.1 Thermal Treatment (Enclosed Ground Flares)

When treatment of LFG is necessary, the most common technology used at CERCLA municipal landfill sites is thermal treatment using enclosed ground flares. Treatment of landfill gas may be necessary in situations where homes or buildings are close to the landfill, when final use of the site includes allowing public access, when the landfill produces excessive odors, or when state or federal air standards are violated. Flares are a well-established technology and are being used at many landfills worldwide.

Enclosed ground flare systems consist of a refractory-lined flame enclosure (or stack) with a burner assembly at its base. A pilot light is installed near the waste-gas burner head. Combustion air dampers are installed at the base of the flare to control excess air. In the operation of an enclosed ground flare system, landfill gas is mixed with a supplemental fuel, if required to support combustion, and fed through a vertical, open-ended pipe. Pilot burners (usually at least three) next to the end of the pipe ignite the waste.

Enclosed ground flares are used extensively for operations involving landfill gas disposal. (They can also be used to burn gases collected from a soil vapor extraction operation.) Earlier operations with landfill gas flaring have consistently used elevated open flares. Open flares are still very common at non-CERCLA municipal landfill sites. However, the enclosed flare is increasingly popular and is, in some instances, being considered the Best Available Control Technology (BACT) for new installations. This emerging technology is a result of the perceived improvement in combustion efficiency and in control of enclosed flares over open flares. Particularly at CERCLA sites, the presence of a visible flame on open flares may cause public concern or may be considered a nuisance. Use of open flares is still common in emergencies or for when the quality and quantity of gas fluctuates widely.

The most important limitation for flare operation is the quality of the gas. If the LFG is less than 20 percent methane, then auxiliary fuel is necessary. Auxiliary fuel is desirable if methane concentration ranges from 20 to 30 percent. If high operating temperatures are desired, additional fuel may be required in any case. Auxiliary fuel will rapidly drive the operational costs up, especially if inexpensive fuel is not available nearby.

Regulatory guidance for flare operation is limited, so operating conditions are usually guided by engineering judgment. The assumed minimum limits for operations are 1,400EF and 1 second of residence time. Data for evaluating destruction efficiency are somewhat limited. The indications are that destruction efficiencies should be greater than 90 percent for most trace air-toxic compounds, with many flares probably realizing greater than 99 percent destruction efficiencies.

Caution should be used when predicting treatment performance. Destruction efficiency can be highly variable, and predicting performance for a specific site may require pilot testing. Most organic compounds should be destroyed effectively with adequate temperature and residence time; however, test data are limited. In many cases, demonstrating high destruction efficiency is difficult because detection levels cannot be measured

precisely using current sampling and analytical protocols. In most cases, enclosed flares consistently achieve greater than 98 percent in overall combustion efficiency. Operations usually can achieve smokeless combustion with no visible flame outside the stack. Enclosed ground flares can be built for virtually any flow of LFG from a landfill site. However, 5,000 standard cubic feet per minute of LFG per flare is a practical upper limit, and lower flows may be more appropriate to allow for operational flexibility and to reduce potential equipment problems.

The EPA Office of Air Quality, Planning, and Standards is developing new source emission guidelines and performance standards for collection and treatment of landfill gas. The air emission standards will apply to new municipal solid waste landfills as well as to those facilities that have accepted waste since November 8, 1987, or that have capacity available for future use. The proposed rule would require an active landfill gas collection and control system for solid waste landfills where emissions exceed 100 megagrams per year of nonmethane organic compounds (NMOC). Control (i.e., treatment) would be achieved using flares. Since the proposed rule is currently under development, some changes may be made. Also, judgment should be used in determining whether these guidelines and standards are relevant and appropriate to a specific CERCLA municipal landfill site. These standards and guidelines were developed for municipal solid waste landfill sites as opposed to CERCLA sites where there is typically co-disposal of both municipal solid waste and hazardous waste.

Some implementation and O&M considerations concerning enclosed ground flares include the following:

- Enclosed ground flares should eliminate odors and air emissions.
- Generally, enclosed ground flares are easy to implement and can be used for short-term as well as long-term applications.
- There is no possibility for heat recovery.

- There is a potential need for steam to control emissions.
- There are high noise levels.
- Costs of supplemental fuel and its availability must be considered.

The data needed for screening and predesign of a flaring system include:

- The quantity (standard cubic feet per minute) of LFG to be treated
- The heat content of waste (Btu/cubic foot)
- Waste constituents, including methane content

Bench or pilot testing is often required to determine destruction and removal efficiencies.

4.4.3 References

Additional references on remedial technologies for LFG are listed below:

Argonne National Laboratory. *An Annotated Bibliography: Environmental Impacts of Sanitary Landfills and Associated Gas Recovery Systems*. ANL/CNSV-27. February 1982.

Emcon Associates-Ann Arbor Science. *Methane Generation and Recovery from Landfills*. 1980.

Lutton, R.J. et al. *Design and Construction of Covers for Solid Waste Landfills*. 600-2-79-165. U.S. Environmental Protection Agency. August 1979.

Noyes Data Corporation. *Landfill Methane Recovery*. Energy Technology Review #80. 1983.

Seebold, James A. *Practical Flare Design*. Chemical Engineering. December 1984.

U.S. Environmental Protection Agency. *RCRA Guidance Document Landfill Design, Liner Systems and Final Cover*. (Draft). July 1982.

4.5 Groundwater

4.5.1 Collection, Treatment, and Disposal

Collection and treatment of groundwater is a common component of the overall remediation of municipal landfill sites. Typically, groundwater is extracted at the perimeter of the landfill to manage offsite migration of leachate and is extracted downgradient to capture the contaminated groundwater plume. The two types of groundwater collection systems used most often are extraction wells and subsurface drains.

Subsurface drains (which are also often used for leachate collection) consist of underground, gravel-filled trenches generally equipped with tile or perforated pipe for greater hydraulic efficiency. The drains can be used to collect contaminated groundwater and transport it to a central area for treatment or proper disposal. Drains are typically used in geological units of low permeability.

Extraction wells are used more frequently than subsurface drains. Well diameter, flow rate, and spacing are determined based on the desired groundwater capture zone and the hydrogeologic characteristics of the aquifer.

Contaminated groundwater is usually treated and disposed of along with leachate (see Section 4.3.2). The chemical parameters that are typically elevated in samples of contaminated groundwater from municipal landfill sites include BOD, COD, VOC, TDS, chloride, nitrite, ammonia, total phosphorous, sulfides, and metals. As with leachate, treatment of contaminated groundwater (or pretreatment in cases where discharge is to a POTW) may involve conventional treatment systems such as biological treatment (organic removal), metals precipitation, and air stripping or GAC for VOC removal (polishing).

4.5.2 Containment

4.5.2.1 Vertical Barriers (Slurry Walls)

Vertical barriers may be a viable technology for groundwater containment at municipal landfill sites. Their use warrants some consideration

since they may improve the overall effectiveness of a containment system. Extraction wells are often used with slurry walls to increase the effectiveness of the slurry wall by creating an inward groundwater gradient. In some cases, groundwater extraction wells alone may provide adequate containment of contaminated groundwater.

An upgradient barrier may be used to reduce the amount of groundwater contacting a contaminated area whereas a downgradient barrier may be used to restrict the migration of contaminated groundwater away from a contaminated area. These barriers acting alone are probably not suitable for most landfill sites because of their limited effects on movement of groundwater. It is difficult to completely intercept groundwater using just slurry walls, therefore, they are usually implemented with other containment technologies such as a groundwater extraction system and landfill cap.

An ideal barrier will completely encircle the landfill area, will be keyed into a lower aquitard (impervious layer), and will include a low permeability cap and a groundwater collection system to maintain an inward hydraulic gradient across the barrier. Such a barrier is generally much more effective in controlling movement of groundwater and pollutants than an upgradient or downgradient barrier or a partially-penetrating barrier (that is, one that is not keyed in to an impervious layer).

The most common type of vertical barrier used at landfill sites, (as well as other hazardous waste sites) is a soil-bentonite slurry wall. Soil-bentonite slurry walls are used as vertical barriers to reduce the horizontal permeability of soil. These walls can be excavated a limited distance into rock material (i.e., keyed into bedrock) but are not generally installed in rock.

Typically, the wall is constructed using a backhoe or specialty clamshell, which is used to excavate a trench 2.5 to 4 feet wide in one pass. The trench is kept open by the use of a bentonite slurry. In addition, this bentonite slurry creates a filter cake on the sides of the trench as the slurry flows laterally into the soil. This filter cake consists of a layer of bentonite with low permeability.

Trenches are generally less than 200 feet deep. Trenches up to 50 feet deep are usually excavated using special backhoes; deeper trenches are excavated with clamshells or other equipment.

The soil excavated from the trench is usually used as backfill material to mix with the bentonite slurry. Where sufficient fines are not present (10 to 30 percent by weight that can pass through a No. 200 sieve), additional fines from adjacent borrow areas and/or bentonite may be added to decrease the permeability. The backfill mixing is generally done adjacent to the trench and requires an area at least as wide as the depth of the trench. The backfill material is then placed into the trench using a bulldozer.

The permeability of the composite trench will generally be in the order of 1×10^{-7} to 1×10^{-6} cm/sec, depending on the type of backfill material used. The backfill permeability is sometimes affected by the migrating contaminants, and compatibility testing should be performed to determine this effect. For example, if there is migration of nonaqueous-phase solvent from the landfill, the bentonite slurry may not be an effective barrier. Other design considerations include the piping of the bentonite fines into the trench under pressure in situations where there is large differential in water pressure on the barrier.

Some implementation and O&M considerations concerning slurry walls include the following:

- Slurry walls can improve the overall effectiveness of a containment system by using the walls in conjunction with extraction wells and a landfill cap.
- A slurry wall is generally a relatively low cost, proven technology.
- The necessary construction equipment is widely available.
- The use of slurry walls is generally limited to relatively flat and unconfined sites.

- For a slurry wall to be effective, the geologic characteristics of the site should allow it to be keyed into bedrock or into an aquitard.
- There may be problems with construction if the landfill site is located within a wetland area.
- There may be construction difficulties for slurry walls deeper than 50 feet.
- The production of large quantities of excess slurry (for deep trenches) that may have to be disposed of as a hazardous waste should be considered.
- A distance of 50 to 75 feet of open area adjacent to the trench is required for mixing bentonite with backfill materials.

The primary data needed for designing a slurry wall include:

- Existing topography and boundary of the proposed slurry wall. (The construction of a slurry wall requires relatively flat topography and sufficient area to mix the bentonite slurry and operate excavation equipment.)
- Geologic data such as soils type, soil chemistry, and types of subsurface formations
- Depth to aquitard and groundwater as well as rate and direction of flow
- Chemical characterization of leachate, groundwater, and landfill wastes (Compatibility testing with slurry wall material may also be required.)

4.5.3 References

Additional references on groundwater remediation are listed below.

Collection, Treatment, and Disposal

Clark, Viessman, and Hammer. *Water Supply and*

Pollution Control. IEP-Dun-Donnell. New York. 1977.

Freeze et al. *Groundwater*. Prentice-Hall, Inc. Englewood Cliffs, New Jersey. 1979.

Keely. *Optimizing Pumping Strategies for Contaminant Studies and Remedial Actions*. Groundwater Monitoring Review. 1984. p. 63-14.

Keely and Tsang. *Velocity Plots and Capture Zones of Pumping Centers for Groundwater Investigations*: Groundwater, Vol. 21, No. 6. 1983. p. 701-14.

Metcalf & Eddy, Inc., revised by Tchobanoglous. *Wastewater Engineering: Treatment, Disposal, Reuse*. 2nd Ed. McGraw-Hill. New York, New York. 1979.

Treybal, R. *Mass Transfer Operations*. 3rd Ed. McGraw-Hill. 1983.

U.S. Environmental Protection Agency. *Handbook of Remedial Action of Waste Disposal Sites*. (Revised) EPA/625/6-85/006. October 1985.

U.S. Environmental Protection Agency. *RCRA, Groundwater Monitoring Technical Enforcement Guidance Document*. OSWER-9950.1. September 1986.

U.S. Environmental Protection Agency. *Technology Briefs, Data Requirements for Selecting Remedial Action Technology*. EPA/600/2-87/001. January 1987.

U.S. Environmental Protection Agency. *Guidance on Remedial Actions for Contaminated Groundwater at Superfund Sites*. EPA/540/6-88/003. December 1988.

U.S. Environmental Protection Agency. *Evaluation of Groundwater Extraction Remedies, Volume I, Summary Report*. EPA/540/2-89/054. September 1989.

U.S. Environmental Protection Agency. *Performance Evaluations of Pump and Treat Remediations: Groundwater Issue Paper*. EPA/540/4-89/005. 1989.

U.S. Environmental Protection Agency. *Basics of Pump and Treat Groundwater Remediation Technologies*. EPA/600/8-90/003, March 1990.

U.S. Environmental Protection Agency. *CERCLA Site Discharges to POTWs*. EPA/540/6-90/005. August 1990.

Xanthakos, P. *Slurry Walls*, New York. McGraw-Hill. 1979.

4.6 Wetlands

Many municipal landfill sites may have been built on or adjacent to natural wetlands and remedial activities may affect the wetland habitat. This section briefly reviews the possible consequences to wetlands of a nearby municipal landfill at an NPL site, and provides a rationale for mitigating unavoidable damage. Two topics are discussed: removing or managing contaminated wetland soil, and mitigating the effects on wetlands of site remediation. When evaluating damage to environmentally sensitive areas, consideration should also be given to potential natural resource damage claims.

4.6.1 Removal or Management of Wetlands Sediments

Wetlands adjacent to municipal landfills may be contaminated by inflows of leachate through surface water and groundwater pathways including springs and seeps. Anaerobic sediments in the wetlands may concentrate and sequester heavy metals or complex organics present in the leachate. These compounds may reach levels that are hazardous to humans or to the biological components (flora and fauna) of the wetland. Under these conditions, remediation of the wetland areas may be required. Wetlands sediments can be physically removed through dredging and then disposed of with other hazardous solids.

Because of the potential for dredging to harm indigenous wetland biota, it should be considered only as a last resort after a careful environmental risk assessment of the site demonstrates that a significant risk actually exists. If the potential for

risk is marginal and is outweighed by the potential for environmental harm from sediment removal, then sediment pollutants can be stabilized and reduced over time by liming, bioremediation, or other technologies. Adding lime to a wetlands area would be done to neutralize acidic groundwater or leachate that had migrated into the wetland. In situ stabilization could potentially be used to immobilize contaminated sediments, although this may harm wetland biota. In situ bioremediation could potentially be implemented to reduce concentration of organic contamination over time. More information on these and other technologies can be found in the document titled *Handbook of Remedial Action at Waste Disposal Sites* (U.S. EPA, 1985a). This onsite management of contaminated sediments may require monitoring to verify the rate of contaminant reduction.

4.6.2 Mitigating Wetlands Losses

When existing natural wetlands must be disturbed through the removal of contaminated sediments to protect human health and the environment, alternative approaches may be used to compensate for the functional loss of wetlands. To this end, disturbance to wetlands will be minimized if the affected area is as small as possible. The effects of dredging may be mitigated by timing dredging activities to avoid critical biota lifestages (for example, dredging can be conducted when plant populations are dormant and migratory wildlife are not present). Silt screens, hay bales, and other construction techniques should be used to minimize the potential for migration of contaminated sediments during dredging activities. In addition, compensation for wetland loss may be achieved by restoring damaged wetlands or creating new wetlands. Restoration may include enhancing water flows to or natural hydrology of existing drained wetlands. Restoration provides faster and more valuable habitat enhancement than does creation of new wetlands. However, creation of new wetlands may be necessary when restoration is not possible.

Creating wetlands can also mitigate the wetlands damage associated with some remedial activities at municipal landfill sites. To the greatest extent practical, new wetlands should provide functional values greater than or equal

to the values lost from the effected wetland. These values can be assessed using the Corps of Engineers Wetlands Evaluation Technique. Additional information can be found in the document titled *Wetland Evaluation Technique (WET)*, Volume II: Methodology, Corps of Engineers (U.S. Army Corps of Engineers, 1987). When practical, created wetlands should be of the same general habitat type as the areas that were affected and should be located in the same watershed. Since larger, contiguous wetland areas generally provide better habitat and associated environmental values than smaller, isolated wetlands, new wetlands should be constructed as part of larger wetlands/aquatic systems. A larger, new wetland area may be created to offset the loss of a number of smaller, isolated wetlands affected by municipal landfill remediation.

4.6.3 References

Additional information on evaluation and mitigation of wetlands can be found in the following documents:

Adamus, P.E., et al. *Wetland Evaluation Technique (WET): Volume II--Methodology*. U.S. Army Corps of Engineers. 1987.

Hammer, D.A. *Constructed Wetlands for Wastewater Treatment*. Lewis Publishers, Chelsea, Michigan. 1989.

U.S. Army Corps of Engineers. *Wetland Evaluation Technique (WET)*. U.S. Army Engineer Waterways Experiment Station. Wetlands Research Program. 1987.

U.S. Environmental Protection Agency. *Constructed Wetlands and Aquatic Plant Systems for Municipal Wastewater Treatment*. (Design Manual) EPA/625/1-88/022. 1988.

U.S. Fish and Wildlife Service, et al. *Federal Manual for Identifying and Delineating Jurisdictional Wetlands*. An Interagency Cooperative Publication. 1989.

4.7 Surface Water and Sediments

4.7.1 Treatment of Surface Water

Generally, surface waters such as large ponds, rivers, or streams are not treated at municipal landfill sites. However, in situations where small onsite ponds or lagoons exist, it may be viable to treat and dispose of contaminated surface water. Management of surface waters in these instances will likely be done in conjunction with contaminated groundwater and leachate. Contaminated surface water will likely be more dilute than leachate or groundwater and may require only minor polishing. Although, this may not be true for onsite lagoons in situations where disposal of liquid wastes may have occurred. Typically, removal of VOCs and semivolatile compounds from surface water may be achieved using air stripping and/or GAC. More concentrated waste streams may also require neutralization, metals precipitation, and biological treatment for removal of COD and BOD. In situ stabilization is also commonly used for lagoon closures for wastes containing primarily inorganic contaminants and 10 to 20 percent of organic constituents. Additional discussion regarding viable treatment technologies can be found in Section 4.3.2. Since treatment of surface waters will likely be for a short duration compared to groundwater or leachate treatment, routing surface water to the groundwater treatment system may be feasible, or it may make sense to use portable (skid mounted) treatment units if additional capacity is needed.

4.7.2 Removal and Management of Sediments

In some cases, it may be necessary to remove contaminated sediments from adjacent surface waters. Because of the potential for dredging to harm indigenous biota, dredging should be considered only after a careful risk assessment demonstrates that a significant risk actually exists from contaminated sediments. When evaluating the risks posed by contaminated sediments, consideration should also be given to the potential for environmental harm from

sediment removal. However, with this in mind, a risk assessment for a particular site may result in the conclusion that removal of contaminated sediments is necessary to mitigate unacceptable risks to human health or the environment.

When excavating sediments below the water surface (dredging) the type of equipment depends on considerations such as the need to control secondary migration, the depth of the contaminated sediment, the consistency of the contaminated sediment, the size of the area to be excavated, and the depth of excavation. For small deposits, the sediment may be reached from shore using a backhoe or clamshell. For large deposits, equipment such as a floating clamshell, backhoe, or a cutterhead hydraulic dredge should be considered. The most feasible and common alternative for managing excavated sediments is to consolidate them with other landfill material under the landfill cap, although sediments may need to be filtered prior to consolidation to remove excess water. See the discussion on ARARs (Section 5.2) for municipal landfill sites regarding the viability of consolidation of sediments managed as a hazardous waste. Excavation of contaminated material will include semi-solids and sediments.

Semi-solids are composed of saturated earth or other materials that have the consistency of wet concrete. These materials may flow when disturbed and are too soft for excavation with ordinary earth-moving equipment such as bulldozers or front-end loaders. Tracked equipment may be used working from firm ground or barge mounted equipment can be used. Accurate control of the depth of excavation of semi-solids is difficult with draglines and crane-suspended clam shells. More accuracy can be obtained by using a toothless bucket as found on a "Gradall" (used for cleaning ditches and slopes) or as adapted to a conventional backhoe. Cutterhead dredges can also be operated with reasonable accuracy.

Sediments are fluid-like deposits that do not hold their shape and must be excavated as a slurry. This requires handling large volumes of water (frequently 80 to 90 percent). Excavation equipment may be either floating or operated from shore. Equipment used for removing sediments may

include hydraulic dredges (with or without cutterhead), barge-mounted pumps, vacuum trucks, or a pneumatic dredge. In pneumatic dredging, compressed air is injected into a Venturi pipe, and air, water, and sediment is lifted and discharged at the surface.

Secondary migration is often a problem with sediment removal below water and thus may require dewatering of the excavation area, using sediment control barriers to minimize migration of sediments, or conducting a final sweep of the area to remove any redeposited sediment. Dewatering a submerged site is often advantageous because it minimizes the contaminated liquid that is carried with the solids. Post-removal verification sampling can also be difficult without dewatering. Temporary dewatering is done by driving sheet metal piling or shoring into the ground around the excavation area and continuously pumping (that is baling) water out of the area until excavation is complete.

4.7.3 References

Additional references on remedial technologies for surface water and sediments are listed below:

U.S. Environmental Protection Agency. *Handbook of Remedial Action at Waste Disposal Sites (Revised)*. EPA/625/6-85/006. October 1985.

U.S. Environmental Protection Agency. *The Superfund Innovative Technology Evaluation Program: Technology Profiles*. EPA/540/5-89/033. November 1989.

U.S. Environmental Protection Agency. *Systems to Accelerate In Situ Stabilization of Waste Deposits*. EPA/540/2-86/002. September 1986.

U.S. Steel. *Steel Sheet Piling Handbook*. 1976.

4.8 Section 4 Summary

This section provides a description of technologies most practicable for remediation of CERCLA municipal landfill sites. This list of technologies is based on the NCP expectations and a review of remedial actions selected in

RODs for CERCLA municipal landfill sites through FY 1989.

In Section 5, these technologies are analyzed against each of the nine criteria used to evaluate

alternatives at Superfund sites. The objective is to illustrate how each technology might affect the alternative evaluation process.

Section 5

EVALUATION CRITERIA

Once remedial action alternatives are sufficiently defined, each alternative is assessed against nine evaluation criteria. During the detailed analysis of alternatives, these criteria are considered individual and are equally weighted for importance. For the purpose of this section, the evaluation criteria have been divided into three groups based on the function of the criteria during remedy selection. The three groups include the threshold criteria, the balancing criteria, and the modifying criteria.

The **threshold criteria** relate to statutory requirements that each alternative must satisfy in order to be eligible for selection. These are:

- Overall protection of human health and the environment--The assessment against this criterion describes how the alternative, as a whole, achieves and maintains protection of human health and the environment.
- Compliance with applicable or relevant and appropriate requirements (ARARs), unless a waiver is obtained--Under this criterion, an alternative is assessed in terms of its compliance with ARARs, or if a waiver is required, how it is justified.

The **balancing criteria** are the technical criteria that are considered during the detailed analysis. The technologies identified as being most practicable for remediation of CERCLA municipal landfill sites have, therefore, been evaluated in light of the following feasibility study balancing criteria:

- Long-term effectiveness and permanence--Under this criterion, an alternative is assessed in terms of its long-term effectiveness in maintaining protection of human health and the environment after response objectives have been met. The magnitude of residual risk and adequacy and reliability of controls are taken into consideration.

- Reduction of toxicity, mobility, or volume (TMV) through treatment--Under this criterion, an alternative is assessed in terms of the anticipated performance of the specific treatment technologies it employs. Factors such as the volume of materials destroyed or treated, the degree of expected reductions, the degree to which treatment is irreversible, and the type and quantity of remaining residuals are taken into consideration.
- short-term effectiveness--Under this criterion, an alternative is assessed in terms of its effectiveness in protecting human health and the environment during the construction and implementation of a remedy before response objectives have been met. The time until the response objectives have been met is also factored into this criterion.
- Implementability--Under this criterion, an alternative is assessed in terms of its technical and administrative feasibility and the availability of required goods and services. Also considered is the reliability of the technology, the ability to monitor the effectiveness of the remedy, and the ease of undertaking additional remedial actions, if necessary.
- Cost--Under this criterion, an alternative is assessed in terms of its present worth capital and operation and maintenance (O&M) costs.

Each of the five balancing criteria represents a significant element of the evaluation process. However, in the case of certain technologies frequently used at municipal landfills, evaluation under some of the five criteria may require less analysis. For example, a clay cap does not reduce TMV through treatment, so the evaluation of a clay cap under this criterion does not require any effort, regardless of the site. Even though these criteria do not require additional

analysis to evaluate, the basic conclusion will still be important during the alternative evaluation. It should be noted that all alternatives may not need to be evaluated with respect to all of a criterion's subcriteria. The key is to identify the subcriteria by which the alternatives vary significantly and to focus the evaluation on those factors.

Table 5-1 identifies technologies frequently used at municipal landfill sites and summarizes how the technology may affect the alternative evaluation criteria. The objective of the table is to present basic conclusions that can be made for each technology in light of each of the balancing criteria, and to identify for each technology the level of effort required under each criterion. The effort for analysis (i.e., level of analysis) is deemed low, moderate, or significant, depending on the technology being considered for inclusion in a particular alternative. For example, using incineration as part of an alternative may require significant analysis of potential risks to human health and the environment due to air emissions from the incinerator. The two threshold criteria (overall protectiveness of human health and the environment, and compliance with ARARs) have not been included in Table 5-1 because these criteria are evaluated only once the technologies have been assembled into complete alternatives.

The **modifying criteria** are formally assessed after the public comment period. However, state or community views are considered during the feasibility study to the extent they are known. The modifying criteria are as follows:

- State/support agency acceptance
- Community acceptance

Communication with the state/support agency and community is initiated during scoping and continues throughout the RI/FS. Once the preferred alternative has been identified in the proposed plan, and the proposed plan has been issued for public comment, these criteria are evaluated. Based on the comments received during the formal comment period, the lead agency may modify aspects of the

preferred alternative or decide that another alternative is more appropriate. More information about all of the criteria, including a comprehensive list of subcriteria, can be found in Chapter 6 of *Guidance for Conducting Remedial Investigations and Feasibility Studies Under CERCLA* (U.S. EPA, 1988d). Below, a summary is provided regarding all criteria as they affect municipal landfill sites.

5.1 Overall Protection of Human Health and the Environment

When evaluating alternatives in terms of overall protection of human health and the environment, consideration should be given to the manner in which site risks identified in the conceptual site model are eliminated, reduced, or controlled through treatment, engineering controls (for example, containment), or institutional controls. Potential threats to human health and the environment resulting from municipal landfills may include:

- Leachate generation and groundwater contamination
- Soil contamination (including hot spots)
- The landfill contents themselves
- Landfill gas
- Wetlands contamination
- Contamination of surface waters and sediments

The overall assessment of protection of human health and the environment is based on evaluating how each of these potential threats has been addressed in terms of a composite of factors assessed under other evaluation criteria, especially long-term effectiveness and permanence, short-term effectiveness, and compliance with ARARs.

**Table 5-1
EVALUATION OF TECHNOLOGIES FREQUENTLY USED AT
MUNICIPAL LANDFILLS**

Technology	Evaluation in Terms of Long-Term Effectiveness and Permanence	Evaluation in Terms of Reduction of TMV Through Treatment	Evaluation in Terms of Short-Term Effectiveness	Evaluation in Terms of Implementability	Evaluation in Terms of Cost
Deed Restrictions	Relies on access development restrictions to manage residual risk. Difficulty in enforcement results in low reliability of controls. Because of virtually no long-term effectiveness, almost no effort to evaluate.	Not a treatment technology. No effort to evaluate.	No health or environment impacts during implementation. This criteria is not very important for this technology and will not vary from site to site. Almost no effort to evaluate.	Ability to implement depends on local ordinances. May be difficult if legal requirements are not in place, especially offsite. Owner approval needed for deed restrictions. Important criteria since the ability to implement will vary from site to site. Need to contact state or local authorities. Significant effort to evaluate.	Low. Significant effort (difficult) to cost but is a minor cost.
Fencing	Relies on limiting access to manage residual risk from direct contact. Reliability of controls is uncertain. Fencing limits access to the site although trespassing is possible. Because of virtually no long-term effectiveness, almost no effort to evaluate.	Not a treatment technology. No effort to evaluate.	With the exception of physical hazards associated with routine construction activities, minimal health or environmental impacts during implementation. Almost no effort to evaluate.	Easy to implement. Equipment readily available. Almost no effort to evaluate.	Low. Little effort to cost.
Grading/ Revegetation	Minimal reduction of residual risk, may reduce risk from direct contact and reduce leachate formation by controlling runoff. May lessen risk from direct contact. Continued maintenance required to achieve long-term reliability. Because of virtually no long-term effectiveness, almost no effort to evaluate.	Not a treatment technology. No effort to evaluate.	Inhalation and direct contact risk if waste is disturbed. Proper health and safety protection may mitigate risk. If risk is quantified, moderate effort to evaluate.	Easy to implement. Almost no effort to evaluate.	Low. Little effort to cost.
Soil Cover	Reduction of residual risk from direct contact. With proper maintenance is reliable in longer term. May use HELP model to evaluate leachate reduction. Significant effort to evaluate.	Not a treatment technology. No effort to evaluate.	Inhalation and direct contact risk if waste is disturbed. Community impact through increased dust and noise from construction and truck traffic if soil is from offsite. Need to determine amount of truck traffic and risk from vehicular and construction accidents. Moderate effort to evaluate.	Easy to implement. Determine presence of soil nearby. Moderate effort to evaluate.	Low. Moderate effort to cost.
Single-Barrier Cap	Reduction of residual risk from direct contact. Lessens future leachate formation and subsequent groundwater contamination by reducing potential for infiltration by 70-90 percent. Requires long-term maintenance. May use HELP model and risk assessment to help evaluate. Significant effort to evaluate.	Not a treatment technology. No effort to evaluate.	Inhalation and direct contact risk to workers if waste is disturbed. Community impact through increased dust and noise from construction and truck traffic if clay source if offsite. Need to determine amount of truck traffic and risk from vehicular and construction accidents. Moderate effort to evaluate.	For a clay cap, relatively easy to implement. Need local source of clay, which may be difficult to find in certain regions. Synthetic liner requires specialty contractors to assure proper installation. Moderate effort to evaluate.	Medium if landfill is large. Moderate effort to cost.
Composite-Barrier Cap	Reduction of residual risk from direct contact. Minimizes future leachate formation and groundwater contamination by virtually eliminating infiltration (99 percent reduction). Will last for 20 to 30 years before replacement is needed if properly designed and maintained. Greater reliability than single barrier cap because of redundancy of barriers, although reliability with large differential settlements may be poor. May use HELP model or risk assessment. Significant effort to evaluate.	Not a treatment technology. No effort to evaluate.	Inhalation and direct contact risk to workers if waste is disturbed. Community impact through increased truck traffic if clay/soil source is offsite. Need to determine amount of truck traffic and risk from vehicular and construction accidents. Moderate effort to evaluate.	Synthetic liner requires specialty contractors to assure proper installation. Need a source of clay, which may be difficult to obtain in some regions. Determine presence of clay nearby. Moderate effort to evaluate.	Medium-High, depending on size of landfill. Moderate effort to cost.

**Table 5-1
EVALUATION OF TECHNOLOGIES FREQUENTLY USED AT
MUNICIPAL LANDFILLS**

Technology	Evaluation in Terms of Long-Term Effectiveness and Permanence	Evaluation in Terms of Reduction of TMV Through Treatment	Evaluation in Terms of Short-Term Effectiveness	Evaluation in Terms of Implementability	Evaluation in Terms of Cost
Excavation: Consolidation	Long-term effectiveness same as cap after consolidation. May use a risk assessment. May need significant effort to evaluate.	Not a treatment technology. No effort to evaluate.	Disturbance of waste is a risk to workers. Proper health and safety requirements may mitigate risk. Community impacts through volatilization of waste, dust, and increased truck traffic if cap source is offsite. Significant effort to evaluate to determine volatilization risk, amount of truck traffic, and risk from vehicular and construction accident.	Same as cap chosen; if dewatering of excavation volume is large, may complicate implementation. Sampling needed to determine extent of hot spot. Significant effort to evaluate depending on extent of RI data.	Medium-High, depending on area being considered. Moderate effort to cost.
Excavation of Hot Spots: Offsite Disposal at Landfill	Effectiveness dependent on the type of offsite facility and whether or not there was a significant reduction in risk due to excavating the hot spot area. Significant effort to evaluate if use risk assessment.	Not a treatment technology. No effort to evaluate.	Disturbance of waste is risk to workers. Community impacts through volatilization, transport of hazardous material through community, and increased truck traffic. Significant effort to evaluate to determine volatility risk, release of hazardous waste risk, extent of truck traffic, and risk from vehicular and construction accidents.	Same as cap plus possible added difficulty of excavating waste in water. Sampling needed to determine extent of hot spots. Need to find hazardous waste landfill with capacity. Significant effort to evaluate.	Medium-High. Moderate effort to cost.
Excavation of Hot Spots: Onsite Incineration	Less residual waste onsite to manage. The reduction in risk will depend on how much of the overall risk posed by the site has been reduced by excavating the hot spot area. Incineration very effective in long-term for hot spot waste. Significant effort to evaluate if risk assessment is conducted.	Treatment to reduce toxicity, mobility, and volume. The significance of TMV reduction will depend on the magnitude of the threat the hot spot area posed. Moderate effort to evaluate.	Possible impacts from disturbance of waste and improper air emissions. No hazardous waste taken through community. Significant effort to evaluate by determining risk from air emissions.	Metals present may still fail TCLP characteristic test. It may be difficult to control air emissions and sufficient space must be available on site. Significant effort to evaluate.	High. Significant effort to cost.
Stabilization	Improved long-term effectiveness over cap alone if used with cap. If used for outlying hot spots without cap will result in some reduction in risk but will not be as effective as excavation by reducing mobility and consolidation under a cap. May not be effective in immobilizing organic contaminants. All waste remains. Need to determine permanence and long-term risk. May be significant effort to evaluate.	Reduction in mobility of contaminants. No reduction in toxicity. Potential increase of waste volume of 10-50 percent. Stabilization may be reversible over time. Significant effort to evaluate.	Significant health and environmental impacts possible because waste is completely mixed. Impacts from odor, dust, and volatiles. Moderate effort to evaluate.	Materials readily available. May be difficult to achieve sufficient mixing in situ to stabilize waste. Need treatability studies to determine feasibility. Significant effort to evaluate.	Medium-High. Significant effort to cost.
Subsurface Drains (leachate & G.W.)	Some risk from groundwater remains for a long time until groundwater remediation is complete. If designed as such, may control further migration. Capture zone analysis may be required. Significant effort to evaluate.	Not a treatment technology. Evaluate with treatment.	No significant impacts during implementation. Drains are usually not installed in landfill. Long time needed to achieve cleanup goals. Significant effort required to determine time until cleanup goals are met.	Easy to implement if subsurface is consistent with well known. Wells not reliable in fractured bedrock. Significant effort to evaluate.	Low-Medium. Significant effort to cost.
Groundwater Extraction Wells (leachate & G.W.)	Some risk from groundwater remains for a long time until groundwater remediation is complete. May effectively control further migration of contaminated groundwater migration. Capture zone analysis may be required. Significant effort to evaluate.	Not a treatment technology. Evaluate with treatment.	Installation of wells in landfill material may result in impacts to the community and workers from potential VOC emissions. Also, drilling creates potential explosion hazards. Significant effort required to determine time until cleanup goals are met.	Easy to implement if subsurface is consistent and well-defined. Wells not reliable in fractured bedrock. Significant effort to evaluate.	Low-Medium. Significant effort to cost.

**Table 5-1
EVALUATION OF TECHNOLOGIES FREQUENTLY USED AT
MUNICIPAL LANDFILLS**

Technology	Evaluation in Terms of Long-Term Effectiveness and Permanence	Evaluation in Terms of Reduction of TMV Through Treatment	Evaluation in Terms of Short-Term Effectiveness	Evaluation in Terms of Implementability	Evaluation in Terms of Cost
Onsite Water Treatment and Discharge (leachate and G.W.)	Conventional technologies used to treat leachate and GW (metals precip, air stripping, GAC, bio treatment) are proven and reliable as long as O&M is continued and proper disposal assumed. Significant effort to determine influent and effluent concentrations and reliability.	Treatment provides a reduction in toxicity and/or volume depending on the process option selected. There may be residuals left in the form of sludge or carbon. Treatment is not necessarily irreversible. Significant effort to evaluate.	If air stripping is used without gaseous control, may be some impacts. Ultimate disposal of water and residuals may have an impact. Time until environmental clean up goals are met depends on extraction. Collection system may have to be operated permanently because there are continued loadings from the landfill. Very difficult to reliability predict when groundwater goals can be met at landfill perimeter. Significant effort to evaluate.	Usually easy to implement and equipment is available. Treatment of leachate and GW generally uses conventional, proven technologies. Unusual processes may be more difficult. Discharge requires either NPDES permit or meeting substantive requirements of the permit.	Low-Medium. Moderate effort to cost.
Treatment of POTW	May not be reliable as onsite treatment since the POTWs typically do not remove all hazardous constituents. Contaminants may accumulate in sludges, and proper disposal may not be assured. Potentially less reliable in rural areas with small systems. Difficult to determine reliability. Significant effort to evaluate.	Toxicity and/or volume may be reduced by POTW. However, residuals remain. Significant effort to evaluate.	Transport of water via pipe has potential for negative impacts on the environment via spills, pipe rupture, leaks resulting in infiltration. POTW bypasses through overflows, exposure to POTW workers. Significant effort to evaluate to determine environmental impacts.	Often, POTWs refuse to accept water, even if pretreated. Reliability is plant specific. POTW would need additional monitoring to evaluate effectiveness. Significant effort to determine feasibility and find capacity.	Low. Significant effort to cost. Depends on information supplied by POTW.
Slurry Walls	Difficult to maintain and therefore may not provide long-term reliability Moderate effort to evaluate because of difficult to quantify, may be qualitative evaluation.	Not a treatment technology. No effort to evaluate.	If waste is disturbed, may be limited risk to workers or community. Almost no effort to evaluate.	Technical implementability depends on site geologic conditions. Difficult to monitor reliability. Significant effort to evaluate.	Medium-High. Significant effort to cost.
LFG Passive Vents	Not as effective as an active system in controlling offsite migration in the long-term. Primarily protects cap from a buildup of gas and collects gas local to the passive well or trench. Moderate effort to evaluate.	Not a treatment technology. No effort to evaluate.	Protects cap in short-term. May impact the environment and community through gas release. Modeling may be required. Significant effort to evaluate.	Can be installed as part of new cap or in existing cap. Moderate effort to evaluate.	Low. Moderate effort to cost.
Active Gas Collection	Collects gas either through landfill or through subsurface adjacent to landfill. Is effective for long-term collection of gas. With proper disposal, removes most risk from the landfill gas. Modeling may be needed to determine effectiveness. Significant effort to evaluate.	Not a treatment technology. Evaluate with treatment technology.	May be an impact to workers drilling through landfill. Moderate effort to evaluate if waste is disturbed.	Fairly easy to implement as part of new cap or existing cap. Able to monitor effectiveness. Moderate effort to evaluate.	Low-Medium. Significant effort to cost.
LFG Thermal Treatment (Flares)	Effective means of managing collected LFG. Treatment levels may vary over time, requiring long-term monitoring. Significant effort to determine reliability and treatment levels.	Reduces toxicity and volume considerable. Treatment is irreversible. Moderate effort to evaluate although not difficult because of irreversibility.	No significant impact during installation. Even with proper operation, may be slight risk to the community depending on the constituents in the gas. Significant effort to evaluate if modeling is conducted.	Easy to implement. May be difficult to monitor effectiveness because of low detection limits needed. Significant effort to evaluate.	Medium. Significant effort to cost.
Removal, Onsite Consolidation of Sediments	Long-term effectiveness affected by cap type used after consolidation. Effectiveness also depends on magnitude of risk reduced through excavation of sediments. Significant effort to evaluate.	Not a treatment technology. No effort to evaluate.	Disturbance of sediments may further contaminate the surface water. Dredging may have impact on wetlands or surface water biota. Sediments are often left in place to protect aquatic life. Significant effort to evaluate if risk is determined.	Technical difficult to implement due to the possibility of dispersing contamination during dredging. Approval for dewatering/rerouting of stream before excavation may be difficult because of environmental impacts. Sampling during removal needed. Feasibility requires significant effort to evaluate.	Low-Medium. Significant effort to cost.
Compensatory Wetlands	No management of residuals. Only a replacement of damaged wetlands. Effectiveness is not an issue. Almost no effort to evaluate.	Not a treatment technology and no residuals remain. No effort to evaluate.	The construction of wetland in a clean area will have positive environmental impacts. No impact to community or workers if area is clean. Almost no effort to evaluate.	Complex to implement successfully. Many ecological factors need to be taken into account. Significant effort to determine implement ability.	Medium-High. Significant effort to cost, if possible.

5.2 Compliance With ARARS

Onsite remedial actions at CERCLA municipal landfill sites must comply with all ARARs of other environmental statutes, unless a waiver can be justified. These statutes include those established by U.S. EPA and other federal agencies and those established by the state in which the release occurred, if the state's standards are promulgated, more stringent than the federal standards, and are identified in a timely manner.

By way of defining “applicable” and “relevant and appropriate”: *applicable requirements* are federal or state requirements that “specifically address a hazardous substance, pollutant, contaminant, remedial action, location, or other contaminant, remedial action, location, or other circumstance found at a CERCLA site” (NCP Sec. 300.5). *Relevant and appropriate requirements* are federal or state laws that, while not applicable to a hazardous substance, pollutant, contaminant, remedial action, or other circumstance at a CERCLA site, “address problem or situations sufficiently similar to those encountered at the CERCLA site that their use is well suited to the particular site.” (NCP Sec. 300.5).

Another factor in determining which requirements must be compiled with is whether the requirement is substantive or administrative. Onsite CERCLA response actions must comply with substantive requirement of other environmental laws but not with administrative requirements. Substantive requirements include cleanup standards or levels of control; in general, administrative requirements prescribe methods and procedures such as fees, permitting, inspection, and reporting requirements.

In addition to the legally binding requirements established as ARARs, many federal and state programs have developed criteria, advisories, guidelines, or proposed standards “to be considered” (TBC). This TBC material may provide useful information or recommend procedures if (1) no ARAR addresses a particular situation, or (2) if existing ARARs do not provide protection. In such situations, TBC criteria or guidelines should be used to set remedial action levels. Their use should be explained and justified in the administrative record for the site.

A more detailed discussion of the general issues associated with ARARs and TBCs can be found in the following documents: the preamble to the NCP, 55 FR 8741-8766 of March 8, 1990; and *CERCLA Compliance with Other Laws Manual* (U.S. EPA, 1988b).

ARARs are divided into three types:

- Chemical-specific ARARs
- Location-specific ARARs
- Action-specific ARARs

Tables 5-2 and 5-3 list the federal location and action-specific ARARs that typically are pertinent to CERCLA municipal landfill sites. ARARs pertinent to air striping, incineration, and direct discharge to POTWs are also included because these technologies are frequently used at municipal landfill sites. Chemical-specific ARARs have been identified for an example site and are listed in Section 4.1 of Appendix A. A discussion of state ARARs follows the information regarding federal ARARs.

5.2.1 Federal ARARs

5.2.1.1 Chemical-Specific ARARs

Chemical-specific requirements are usually technology- or risk-based numerical limitations or methodologies that, when applied to site-specific conditions, result in the establishment of acceptable concentrations of a chemical that may be found in or discharged to the ambient environment. Information regarding the use of chemical-specific ARARs in risk assessments can be found in the documents *Risk Assessment Guidance for Superfund, Volume II--Human Health Evaluation Manual (Part A)*, Interim Final (U.S. EPA, 1989j), and *Risk Assessment Guidance for Superfund, Volume II--Environmental Evaluation Manual*, Interim Final (U.S. EPA, 1989c). Examples of chemical-specific ARARs and TBCs are listed for the example site and can be found in Appendix A of this report. The following is a discussion of the chemical-specific ARARs that typically are pertinent to landfill site.

**Table 5-2
POTENTIAL FEDERAL LOCATION-SPECIFIC ARARs AT MUNICIPAL LANDFILL SITES**

Location		Requirement	Prerequisite(s)	Citation	Comments
1.	Within 61 meters (200 feet) of a fault displaced in Holocene time	New treatment, storage, or disposal of hazardous waste prohibited.	RCRA hazardous waste; PCB treatment, storage, or disposal.	40 CFR 264.18(a)	Counties considered seismically active listed in 40 CFR 264 Appendix VI.
2.	Within 100-year floodplain	Facility must be designed, constructed, operated, and maintained to avoid washout.	RCRA hazardous waste; PCB treatment, storage or disposal.	40 CFR 264.18(b) 40 CFR 761.75	Applicable if part of the landfill is in the 100-year floodplain.
3.	Within floodplain	Action to avoid adverse effects, minimize potential harm, restore and preserve natural and beneficial values of the floodplain.	Action that will occur in a floodplain, i.e., lowlands, and relatively flat areas adjoining inland and coastal waters and other flood-prone areas.	Executive Order 11988, Protection of Floodplains, (40 CFR 6, Appendix A)	Applicable if part of the landfill is in the 100-year floodplain.
4.	Within salt dome formation, underground mine, or cave	Placement of noncontainerized or bulk liquid hazardous waste prohibited.	RCRA hazardous waste; placement.	40 CFR 264.18(c)	Need to verify that the site does not contain any salt dome formations, underground mines, or caves used for waste disposal.
5.	Critical habitat upon which endangered species or threatened species depends	Action to conserve endangered species or threatened species, including consultation with the Department of the Interior.	Determination of endangered species or threatened species.	Endangered Species Act of 1973 (16 USC 1531 <u>et seq.</u>); 50 CFR Part 200, 50 CFR Part 402	Need to identify whether any endangered species are known to exist on the site. May apply in rural areas.
6.	Wetland	Action to minimize the destruction, loss, or degradation of wetlands. Action to prohibit discharge of dredged or fill material into wetland without permit.	Wetland as defined by Executive Order 11990 Section 7.	Executive Order 11990, Protection of Wetlands, (40 CFR 6, Appendix A) Clean Water Act Section 404; 40 CFR Parts 230, 231	Applicable if wetlands are present next to or on the site.
7.	Wilderness area	Area must be administered in such a manner as will leave it unimpaired as wilderness and to preserve its wilderness character.	Federally owned area designated as wilderness area.	Wilderness Act (16 USC 1131 <u>et seq.</u>); 50 CFR 35.1 <u>et seq.</u>	Need to verify that the site is not within a Federal Wilderness Area.
8.	Wildlife refuge	Only actions allowed under the provisions of 16 USC Section 668 dd(c) may be undertaken in areas that are part of the National Wildlife Refuge System.	Area designated as part of National Wildlife Refuge System.	16 USC 668 dd <u>et seq.</u> ; 50 CFR Part 27	Need to verify that the site is not within a National Wildlife Refuge.

**Table 5-2
POTENTIAL FEDERAL LOCATION-SPECIFIC ARARs AT MUNICIPAL LANDFILL SITES**

Location		Requirement	Prerequisite(s)	Citation	Comments
9.	Area affecting stream or river	Action to protect fish or wildlife.	Diversion, channeling, or other activity that modifies a stream or river and affects fish or wildlife.	Fish and Wildlife Coordination Act (16 USC 661 <u>et seq.</u>); 40 CFR 6.302	The Fish and Wildlife Coordination Act requires consultation with the Department of Fish and Wildlife prior to any action that would alter a body of water of the United States.
10.	Within area affecting national wild, scenic, or recreational river	Avoid taking or assisting in action that will have direct adverse effect on scenic river.	Activities that affect or may affect any of the rivers specified in Section 1276(a).	Scenic Rivers Act (16 USC 1271 <u>et seq.</u> , Section 7(a); 40 CFR 6.302(e)	Need to verify that national wild or scenic rivers are not located on the site and will not be affected by site remediation.
11.	Within coastal zone	Conduct activities in manner consistent with approved state management programs.	Activities affecting the coastal zone including lands thereunder and adjacent shorelands.	Coastal Zone Management Act (16 USC Section 1451 <u>et seq.</u>).	Applicable if the site has direct access to coastal areas.
12.	Oceans or waters of the United States	Action to dispose of dredge and fill material into ocean waters is prohibited without a permit.	Oceans and waters of the United States.	Clean Water Act Section 404, 40 CFR 125 Subpart M; Marine Protection Resources and Sanctuary Act Section 103	Applicable if disposal of dredge and fill material in ocean waters is planned.
13.	Within area where action may cause irreparable harm, loss, or destruction of significant artifacts	Action to recover and preserve artifacts.	Alteration of terrain that threatens significant scientific, prehistorical, historical, or archaeological data.	National Archaeological and Historical Preservation Act (16 USC Section 469); 36 CFR Part 65	Should scientific, prehistorical, or historical artifacts be found at the site, this will become applicable.
14.	Historic project owned or controlled by federal agency	Action to preserve historic properties; planning of action to minimize harm to National Historic Landmarks.	Property included in or eligible for the National Register of Historic Places.	National Historic Preservation Act Section 106 (16 USC 470 <u>et seq.</u>) 36 CFR Part 800	Need to identify whether the site is included in the national Register of Historic Places.

Table 5-3

POTENTIAL FEDERAL ACTION-SPECIFIC ARARs FOR MUNICIPAL LANDFILL SITES

Page 1 of 13

Actions	Requirements	Prerequisites	Citation	Comments
Air Stripping	Design system to provide odor-free operation.		CAA Section 101 ^a	Odor regulations are intended to limit nuisance conditions from air pollution emissions.
	File an Air Pollution Emission Notice (APEN) with the State to include estimation of emission rates for each pollutant expected.		40 CFR 52 ^a	State will have particular interest in emissions for compounds on their hazardous, toxic, or odorous list. Preliminary meeting with state prior to filing APEN is recommended in the regulation. Meeting would identify additional issues of concern to the State.
	Include with filed APEN the following: <ul style="list-style-type: none"> Modeled impact analysis of source emissions. Provide a Best Available Control Technology (BACT) review for the source operation. 	This additional work and information is normally applicable to sources meeting the "major" criteria and/or to sources proposed for nonattainment areas.	40 CFR 52 ^a	State may identify further requirements for permit issuance after first review. These provisions follow the federal Prevention of Significant Deterioration(PSD) framework with some modifications. Additional requirements could include ambient monitoring and emission control equipment design revisions to match Lowest Achievable Emission Requirements (LAER). While a permit is not required for an onsite CERCLA action, the substantive requirements identified during the permitting process are applicable.
	Predict total emissions of volatile organic compounds (VOCs) to demonstrate emissions do not exceed 450 lb/hr, 3,000 lb/day, 10 gal/day, or allowable emission levels from similar sources using Reasonable Available Control Technology (RACT).	Source operation must be in an ozone nonattainment area.	40 CFR 52 ^a	The control technology review for this regulation (RACT) could coincide with the BACT review suggested under the PSD program.
	Verify through emission estimates and dispersion modeling that hydrogen sulfide emissions do not create an ambient concentration greater than or equal to 0.10 ppm.		40 CFR 61 ^b	
	Verify that emissions of mercury, vinyl chloride, and benzene do not exceed levels expected from sources in compliance with hazardous air pollution regulations.		40 CFR 61 ^a	Regulation 8 indicates any source emitting the regulated compounds is subject to this regulation. However, some of the specific regulations further restrict the scope of applicability.
Capping	Placement of a cap over hazardous waste (e.g., closing a landfill, or closing a surface impoundment or waste pile as a landfill, or similar action) requires a cover designed and constructed to: <ul style="list-style-type: none"> Provide long-term minimization of infiltration of liquids through the capped area. Function with minimum maintenance. Function with minimum maintenance. Promote drainage and minimize erosion or abrasion of the cover. Accommodate settling and subsidence so that the cover's integrity is maintained. Have a permeability less than or equal to the permeability of any bottom liner system or natural subsoils present. 	RCRA waste in landfill. Significant management (treatment, storage, or disposal) of hazardous waste will make requirements applicable; capping without disturbance will not make requirements applicable, but technical requirements may be relevant and appropriate.	40 CFR 264.228(a) (Surface Impoundments) 40 CFR 264.258(b) (Waste Piles) 40 CFR 264.310(a) (Landfills)	RCRA capping requirements could be relevant and appropriate to capping hazardous wastes in place. RCRA is generally considered relevant if it can be verified, through review of records, interviews, or other means, that the landfill accepted RCRA wastes after November 19, 1980. The appropriateness of RCRA requirements is based also on each requirement's technical merit in a given situation. If a groundwater containment problem exists, a RCRA cap would serve to isolate and contain landfill solids and contaminated soils and limit infiltration of precipitation. EPA guidance on RCRA caps for new RCRA landfill cells includes multibarrier caps of clay and liners. Excavation and reconsolidation of the wastes onsite, in a location outside of the current area of contamination, would make these requirements, as well as the landfill construction and operation requirements applicable for wastes that can be designated as hazardous. If the wastes are excavated and reconsolidated in their current location, the capping requirements are applicable. The major determining factors are the location of the final disposal, and the classification of the waste materials.

**Table 5-3
POTENTIAL FEDERAL ACTION-SPECIFIC ARARs FOR MUNICIPAL LANDFILL SITES**

Actions	Requirements	Prerequisites	Citation	Comments
	<p>Estimate free liquids, stabilize wastes before capping (surface impoundments)</p> <p>Restrict post-closure use of property as necessary to prevent damage to the cover.</p> <p>Prevent run-on and run-off from damaging cover.</p> <p>Protect and maintain surveyed benchmarks used to locate waste cells (landfills, waste piles).</p> <p>Disposal or decontamination of equipment, structures, and soils.</p>		<p>40 CFR 264.228(a)</p> <p>40 CFR 264.117(c)</p> <p>40 CFR 264.228(b) 49 CFR 264.310(b)</p> <p>40 CFR 264.310(b)</p> <p>40 CFR 264.111</p>	
<p>Closure with Waste in Place (Capping)</p>	<p>Eliminate free liquids by removal or solidification.</p> <p>Stabilization of remaining waste and waste residues to support cover.</p> <p>Installation of final cover to provide long-term minimization of infiltration.</p> <p>Post-closure care and groundwater monitoring.</p>		<p>40 CFR 264.228(a)(2)</p> <p>40 CFR 264.228(a)(2) and 40 CFR 264.258(b)</p> <p>40 CFR 264.310</p> <p>40 CFR 264.310</p>	<p>See discussion under Capping.</p>
<p>Clean Closure (Removal)</p>	<p>General performance standard requires minimization of need for further maintenance and control; minimization or elimination of post-closure escape of hazardous waste, hazardous constituents, leachate, contaminated runoff, or hazardous waste decomposition products.</p>	<p>Disturbance of RCRA hazardous waste (listed or characteristic) and movement outside the unit or area of contamination.</p> <p>May apply to surface impoundment or to contaminated soil, including soil from dredging or soil disturbed in the course of drilling or excavation and returned to land.</p>	<p>40 CFR 264.111</p>	<p>Clean closure removal of contaminated materials does not appear to be feasible for most municipal landfill sites because of the large volume of wastes. However, clean closure removal may be considered for portions of the site, such as hot spot areas. The RCRA clean closure requirements would be considered relevant and appropriate to contaminated wastes which are not hazardous, but which are similar to hazardous wastes.</p>
	<p>Disposal of decontamination of equipment, structures, and soils.</p>		<p>40 CFR 264.111 and 268</p>	<p>The RCRA Land Disposal Restrictions require treatment of RCRA wastes to specified levels or by specified technologies. The RCRA requirements would be considered relevant and appropriate to wastes that are not RCRA hazardous wastes, but which are similar (same constituents) as RCRA wastes.</p> <p>RCRA Land Disposal Restrictions require treatment of RCRA wastes to specified levels or by specified technologies before land disposal. If treatment to the specified level or by the specified technology is not achievable or appropriate, a variance must be obtained from the EPA. If the wastes are determined to be RCRA wastes, these requirements would be applicable.</p>

Table 5-3

POTENTIAL FEDERAL ACTION-SPECIFIC ARARs FOR MUNICIPAL LANDFILL SITES

Actions	Requirements	Prerequisites	Citation	Comments
Clean Closure (Removal) (cont'd.)	Removal or decontamination of all waste residues, contaminated containment system components (e.g., liners, dikes), contaminated subsoils, and structures and equipment contaminated with waste and leachate, and management of them as hazardous waste. Meet health-based levels at unit.	Not applicable to undisturbed material. Disposal of RCRA hazardous waste (listed or characteristic) after disturbance and movement outside the unit or area of contamination.	40 CFR 264.228(a)1) and 40 CFR 264.258	In the event that the wastes being removed are determined to be hazardous wastes, the requirements of this section would be applicable.
Consolidation	Area from which materials are removed should be remediated.	Disposal by disturbance of hazardous waste (listed or characteristic) and moving it outside unit or boundary of contaminated area.	See Closure	If nonhazardous wastes are excavated and moved outside the current area of contamination, these requirements will become relevant and appropriate. These regulations are intended to insure that when wastes are consolidated at a central location, the satellite areas (former locations of the wastes) are remediated. If the wastes which are excavated for consolidation are determined to be hazardous wastes, this regulation will be applicable.
	Consolidation in storage piles/storage tanks will trigger storage requirements.		See Container Storage, Tank Storage, Waste Piles in this table.	RCRA requirements for storage in containers, tanks, or piles will be relevant and appropriate for nonhazardous wastes which are similar to RCRA hazardous wastes, or for hazardous wastes disposed prior to November 1980, which are excavated from the site and stored prior to consolidation and/or disposal. If excavated materials can be classified as hazardous wastes, the requirement will be applicable.
	Placement on or in land outside unit boundary or area of contamination will trigger land disposal requirements and restrictions.	After November 8, 1988.	40 CFR 286 (Subpart D)	Certain listed hazardous wastes are not eligible for disposal in landfills or other land-based facilities unless treated to RCRA specified criteria. The requirement may be relevant and appropriate to some nonhazardous wastes at municipal landfill sites which are contaminated with hazardous constituents at levels similar to those in listed wastes, and are excavated for reconsolidation and disposal outside the current area of contamination. If any of the wastes are determined to meet the definitions of the restricted hazardous wastes, the requirements will be applicable.
	Develop fugitive and odor emission control plan for this action if existing site plan is inadequate.		CAA Section 101 ² and 40 CFR 52 ²	Odor regulations are intended to limit nuisance conditions from air pollution emissions. Fugitive emission controls are one feature of the state implementation plan used to achieve/maintain the ambient air quality standards for particulate matter.
	File an Air Pollution Emission Notice (APEN) with state to include estimation of emission rates for each pollutant expected.		40 CFR 52 ²	See discussion under Air Stripping.
	Include with the filed APEN the following: • Modeled impact analysis of source emissions • A Best Available Control Technology (BACT) review for the source operation	This additional work and information is normally applicable to sources meeting the "major" criteria and/or to sources proposed for nonattainment areas.	40 CFR 52 ²	See discussion under Air Stripping.

**Table 5-3
POTENTIAL FEDERAL ACTION-SPECIFIC ARARs FOR MUNICIPAL LANDFILL SITES**

Actions	Requirements	Prerequisites	Citation	Comments
Consolidation (cont'd.)	Predict total emissions of volatile compounds (VOCs) to demonstrate emissions do not exceed 450 lb/hr, 3,000 lb/day, 10 gal/day, or allowable emission levels from similar sources using Reasonably Available Control Technology (RACT).	Source operation must be in an ozone nonattainment area.	40 CFR 52 ^a	See discussion under Air Stripping.
	Verify through emission estimates and dispersion modeling that hydrogen sulfide emissions do not create an ambient concentration greater than or equal to 0.10 ppm.		40 CFR 61 ^a	See discussion under Air Stripping.
	Verify that emissions of mercury, vinyl chloride, and benzene do not exceed levels expected from sources in compliance with hazardous air pollution regulations.		40 CFR 61 ^a	See discussion under Air Stripping.
Containment (Construction of New Surface Impoundment Onsite) (See Closure and Waste in Place and Clean Closure)	Use two liners below the waste, a top liner that prevents waste migration into the liner, and a bottom liner that prevents waste migration through the liner throughout the post-closure period.	RCRA hazardous waste (listed or characteristic) currently being placed in a surface impoundment. Soil/debris being managed as RCRA hazardous waste.	40 CFR 264.220	If a new, onsite surface impoundment is constructed to hold influent and/or effluent from a treatment process, or to hold groundwater, surface water or leachate that is not a hazardous waste, these requirements are relevant and appropriate to construction, operation, and maintenance of the impoundment.
Dike Stabilization	Design and operate facility to prevent overtopping due to overfilling; wind and wave action; rainfall; run-on; malfunctions of level controllers, alarms, or other equipment; and human error.	Existing surface impoundment containing hazardous waste or creation of new surface impoundments.	40 CFR 264.221	These requirements would be relevant and appropriate to the construction and operation of a new surface impoundment or the operation and maintenance of an existing surface impoundment onsite to contain groundwater, surface water, leachate, or the influent or effluent of a treatment system that is not a hazardous waste.
Direct Discharge of Treatment System Effluent	Applicable federal water quality criteria for the protection of aquatic life must be complied with when environmental factors are being considered.	Surface discharge of treated effluent.	50 FR 30784 (July 29, 1985)	
	Applicable federally approved state water quality standards must be complied with. These standards may be in addition to or more stringent than other federal standards under the CWA.	Surface discharge of treated effluent.	40 CFR 122.44 and state regulations approved under 40 CFR 131	If state regulations are more stringent than federal water quality standards, the state standards will be applicable to direct discharge. The state has authority under 40 CFR 131 to implement direct discharge requirements within the state, and should be contacted on a case-by-case basis when direct discharges are contemplated.
	The discharge must be consistent with the requirement of a Water Quality Management plan approved by EPA under Section 208(b) of the Clean Water Act.		CWA Section 208(b)	Discharge must comply with substantive but not administrative requirements of the management plan.
	Use of best available technology (BAT) economically achievable is required to control toxic and nonconventional pollutants. Use of best conventional pollutant control technology (BCT) is required to control conventional pollutants. Technology-based limitations may be determined on a case-by-case basis.	Surface discharge of treated effluent.	40 CFR 122.44(a)	If treated effluent is discharged to surface waters, these treatment requirements will be applicable. Permitting and reporting requirements will be applicable only if the effluent is discharged at an offsite location. The permitting authority should be contacted on a case-by-case basis to determine effluent standards.
	The discharge must conform to applicable water quality requirements when the discharge affects a state other than the certifying state.	Surface water discharge affecting waters outside certifying state.	40 CFR 122.44(d)(4)	No discharge is expected to affect surface water outside certifying state.

**Table 5-3
POTENTIAL FEDERAL ACTION-SPECIFIC ARARs FOR MUNICIPAL LANDFILL SITES**

Actions	Requirements	Prerequisites	Citation	Comments
Direct Discharge of Treatment System Effluent (cont'd.)	Discharge limitations must be established for all toxic pollutants that are or may be discharged at levels greater than those that can be achieved by technology-based standards.	Surface discharge of treated effluent.	40 CFR 122.44(e)	Exact limitations are based on review of the proposed treatment system and receiving water characteristics, and are usually determined on a case-by-case basis. The permitting authority should be contacted to determine effluent limitations.
	Discharger must be monitored to assure compliance. Discharge will monitor: <ul style="list-style-type: none"> • The mass of each pollutant discharged. • The volume of effluent discharged. • Frequency of discharge and other measurements as appropriate. 	Surface discharge of treated effluent.	40 CFR 122.43(i)	These requirements are generally incorporated into permits, which are not required for onsite discharges. The substantive requirements are applicable, however, in that verifiable evidence must be offered that the discharge standards are being met. The permitting authority should be contacted to determine monitoring and operational requirements.
	Approved test methods for waste constituents to be monitored must be followed. Detailed requirements for analytical procedures and quality controls are provided. Permit application information must be submitted, including a description of activities, listing of environmental permits, etc. Monitor and report results as required by permit (at least annually).		40 CFR 122.21 40 CFR 122.44(i)	
	Comply with additional permit conditions such as: <ul style="list-style-type: none"> • Duty to mitigate any adverse effects of any discharge. • Proper operation and maintenance of treatment systems. 		40 CFR 122.41(i)	
	Develop and implement a Best Management Practices (BMP) program and incorporate in the NPDES permit to prevent the release of toxic constituents to surface waters. The BMP program must: <ul style="list-style-type: none"> • Establish specific procedures for the control of toxic and hazardous pollutant spills. • Include a prediction of direction, rate of flow, and total quantity of toxic pollutants where experience indicates a reasonable potential for equipment failure. • Assure proper management of solid and hazardous waste in accordance with regulations promulgated under RCRA. 	Surface water discharge.	40 CFR 125.100 40 CFR 125.104	These issues are determined on a case-by-case basis by the NPDES permitting authority for any proposed surface discharge of treated wastewater. Although a CERCLA site remediation is not required to obtain an NPDES permit for onsite discharges to surface waters, the substantive requirements of the NPDES permit program must be met by the remediation action if possible. The permitting authority should be consulted on a case-by-case basis to determine BMP requirements.

**Table 5-3
POTENTIAL FEDERAL ACTION-SPECIFIC ARARs FOR MUNICIPAL LANDFILL SITES**

Actions	Requirements	Prerequisites	Citation	Comments
Direct Discharge of Treatment System Effluent (cont'd.)	Sample preservation procedures, container materials, and maximum allowable holding times are prescribed.	Surface water discharge	40 CFR 136.1-136.4	These requirements are generally incorporated into permits, which are not required of onsite discharges. The substantive requirements are applicable, however, in that verifiable evidence must be offered that standards are being met. The permitting authority should be consulted on a case-by-case basis to determine analytical requirements.
Discharge to POTW ^d	Pollutants that pass through the POTW without treatment, interfere with POTW operation, or contaminate POTW sludge are prohibited.		40 CFR 403.5	If any liquid is discharged to a POTW, these requirements are applicable. In accordance with guidance, a discharge permit will be required even for an onsite discharge, since permitting is the only substantive control mechanism available to a POTW.
	<p>Specific prohibitions preclude the discharge of pollutants to POTWs that:</p> <ul style="list-style-type: none"> • Create a fire or explosion hazard in the POTW. • Are corrosive (pH<5.0). • Obstruct flow resulting in interference. • Are discharged at a flow rate and/or concentration that will result in interference. • Increase the temperature of wastewater entering the treatment plant that would result in interference; but in no case raise the POTW influent temperature above 104EF (40EC). <p>Discharge must comply with local POTW pretreatment program, including POTW-specific pollutants, spill prevention program requirements, and reporting and monitoring requirements.</p> <p>RCRA permit by rule requirements must be complied with for discharges of RCRA hazardous wastes to POTWs by truck, rail, or dedicated pipe.</p>		<p>40 CFR 403.5 and local POTW regulations</p> <p>40 CFR 264.71 and 40 CFR 264.72</p>	Categorical standards have not been promulgated for CERCLA sites, so discharge standards must be determined on a case-by-case basis, depending on the characteristics of the waste stream and the receiving POTW. Some municipalities have published standards for non-categorical, non-domestic discharges. Changes in the composition of the waste stream due to pretreatment process changes or the addition of new waste streams will require renegotiation of the permit conditions.

**Table 5-3
POTENTIAL FEDERAL ACTION-SPECIFIC ARARs FOR MUNICIPAL LANDFILL SITES**

Actions	Requirements	Prerequisites	Citation	Comments
Discharge of Dredge and Fill Material to Navigable Waters	<p>The five conditions that must be satisfied before dredge and fill is an allowable alternative are:</p> <ul style="list-style-type: none"> • There must be no practicable alternative. • Discharge of dredged or fill material must not cause a violation of state water quality standards, violate any applicable toxic effluent standards, jeopardize an endangered species, or injure a marine sanctuary. • No discharge shall be permitted that will cause or contribute to significant degradation of the water. • Appropriate steps to minimize adverse effects must be taken. • Determine long- and short-term effects on physical, chemical, and biological components of the aquatic ecosystem. 		40 CFR 230.10 33 CFR 320-330	This action is not envisioned as part of the site remediation.
Dredging	Removal of all contaminated sediment.	Disposal by disturbance of hazardous waste and moving it outside the unit or area of contamination.	See discussions under Clean Closure, Consolidation, Capping	
Excavation	Area from which materials are excavated may require cleanup to levels established by closure requirements.	Disposal by disturbance of hazardous waste and moving it outside the unit or area of contamination.	40 CFR 264 Disposal and Closure Requirements	<p>If contaminated materials that are not hazardous wastes are excavated from the site during remediation, the RCRA requirements for disposal and site closure (of the excavated area) may become relevant and appropriate. See discussions under Capping, Clean Closure, Closure with Waste In-Place, etc.</p> <p>If the excavated materials can be classified as hazardous wastes, the disposal and closure requirements would be applicable.</p>
	Movement of excavated materials to a previously uncontaminated, onsite location, and placement in or on land may trigger land disposal restrictions.	Materials containing RCRA hazardous wastes subject to land disposal restrictions.	40 CFR 268 (Subpart D)	<p>The land disposal restrictions restrict disposal of certain hazardous wastes. Some municipal landfill wastes may be derived from or may be sufficiently similar to restricted wastes to make the land disposal restrictions relevant and appropriate.</p> <p>For wastes that can be classified as restricted hazardous wastes, land disposal is prohibited unless they are treated to defined standards. Chemical characterization of the wastes will be necessary to determine the applicability or relevance of this requirement.</p>
	All listed and characteristic hazardous wastes or soils and debris contaminated by a RCRA hazardous waste and removed from a CERCLA site may not be land disposed until treated as required by Land Ban. If alternative treatment technologies can achieve treatment similar to that required by Land Ban, and if this achievement can be documented, then a variance may not be required.	Waste disposed was RCRA waste.	40 CFR 268	If soil is a characteristic waste, and if waste disposed prior to November 1980 is now designated as a RCRA waste, then soils/sediment and leachate contamination from those wastes must be managed as a RCRA waste.

**Table 5-3
POTENTIAL FEDERAL ACTION-SPECIFIC ARARs FOR MUNICIPAL LANDFILL SITES**

Actions	Requirements	Prerequisites	Citation	Comments
Excavation (cont'd.)	Develop fugitive and odor emission control pan for this action if existing site plan is inadequate.		CCA Section 101 ^a and 40 CFR 52 ^a	See discussions under Consolidation.
	File an Air Pollution Emission Notice (APEN) with state to include estimation of emission rates for each pollutant expected.		40 CFR 52 ^a	See discussions under Consolidation.
	Include with the filed APEN the following: <ul style="list-style-type: none"> • Modeled impact analysis of source emissions. • A Best Available Control Technology (BACT) review for the source operation. 	This additional work and information is normally applicable to sources meeting the "major" criteria and/or to sources proposed for nonattainment areas.	40 CFR 52 ^a	See discussions under Consolidation.
	Predict total emissions of volatile organic compounds (VOCs) to demonstrate emissions do not exceed 450 lb/hr, 3,000 lb/day, 10 gal/day, or allowable emission levels from similar sources using Reasonably Available Control Technology (RACT).	Source operation must be in an ozone nonattainment area.	40 CFR 52 ^a	See discussions under Consolidation.
	Verify through emission estimates and dispersion modeling that hydrogen sulfide emissions do not create an ambient concentration greater than or equal to 0.10 ppm.		40 CFR 61 ^a	See discussions under Consolidation.
	Verify that emissions of mercury, vinyl chloride, and benzene do not exceed levels expected from sources in compliance with hazardous air pollution regulations.		40 CFR 61 ^a	See discussions under Consolidation.
Gas Collection	<i>Proposed</i> standards for control of emissions of volatile organics (CAA requirements to be provided).	Proposed standard; not yet ARAR.	52 FR 3748 (February 5, 1987)	This is a proposed rule. If the requirement is finalized in its proposed form, it may be applicable or relevant and appropriate to some of the remedial actions at municipal landfill sites. The proposed standard would impose restrictions on RCRA treatment, storage, and disposal facilities that would limit the allowable emissions of volatile organics from these facilities. If this requirement is finalized, it will be closely examined with respect to remedial alternatives at municipal landfill sites.
	Design system to provide odor-free operation.		CAA Section 101 ^a and 40 CFR 52 ^a	See discussion under Consolidation.
	File an Air Pollution Emission Notice (APEN) with state to include estimation of emission rates for each pollutant expected.		40 CFR 52 ^a	See discussions under Consolidation.
	Include with the filed APEN the following: <ul style="list-style-type: none"> • Modeled impact analysis of source emissions. • A Best Available Control Technology (BACT) review for the source operation. 	This additional work and information is normally applicable to sources meeting the "major" criteria and/or to sources proposed for nonattainment areas.	40 CFR 52 ^a	See discussions under Consolidation.

**Table 5-3
POTENTIAL FEDERAL ACTION-SPECIFIC ARARs FOR MUNICIPAL LANDFILL SITES**

Actions	Requirements	Prerequisites	Citation	Comments
Gas Collection (cont'd.)	Predict total emissions of volatile organic compounds (VOCs) to demonstrate emissions do not exceed 450 lb/hr, 3,000 lb/day, 10 gal/day, or allowable emission levels from similar sources using Reasonably Available Control Technologies (RACT)	Source operation must be in an ozone nonattainment area.	40 CFR 52 ^a	See discussion under Consolidation.
	Verify through emission estimates and dispersion modeling that hydrogen sulfide emissions do not create an ambient concentration greater than or equal to 0.10 ppm.		40 CFR 61 ^a	
	Verify that emissions of mercury, vinyl chloride, and benzene do not exceed levels expected from sources in compliance with hazardous air pollution regulations.		40 CFR 61 ^a	See discussions under Consolidation.
Groundwater Diversion	Excavation of soil for construction of slurry wall may trigger cleanup or land disposal restrictions.	Disposal by disturbance of hazardous waste and moving it outside the unit or area of contamination.	See Consolidation, Excavation in this table.	If waste materials or contaminated soil that are not hazardous wastes are excavated or otherwise disturbed during the construction of a groundwater diversion structure, the requirements of this section would be relevant and appropriate. If the excavated wastes or contaminated soil can be classified as hazardous wastes, these requirements would be applicable.
Incineration (Onsite)	<p>Analyze the waste feed.</p> <p>Dispose of all hazardous waste and residues, including ash, scrubber water, and scrubber sludge.</p> <p>No further requirements apply to incinerators that only burn wastes listed as hazardous solely by virtue of the characteristic of ignitability, corrosivity, or both; or the characteristic of reactivity if the wastes will not be burned when other hazardous wastes are present in the combustion zone; and if the waste analysis shows that the wastes contain none of the hazardous constituents listed in Appendix VIII which might reasonably be expected to be present.</p> <p>Performance standards for incinerators:</p> <ul style="list-style-type: none"> • Achieve a destruction and removal efficiency of 99.99 percent for each principal organic hazardous constituent in the waste feed and 99.9999 percent for PCBs and drums. • Particulate emissions must be less than 180 mg/dscf (.08 grains/dscf) corrected to 7% O₂. • Reduce hydrogen chloride emissions to 1.8 kg/hr or 1 percent of the HCL in the stack gases before entering any pollution control devices. 	RCRA hazardous waste.	<p>40 CFR 264.341</p> <p>40 CFR 264.351</p> <p>40 CFR 264.340</p> <p>40 CFR 264.343</p> <p>40 CFR 264.342</p>	<p>If incineration is selected as one of the remedial alternatives for site remediation, these requirements would be relevant and appropriate to the disposal by incineration of potentially nonhazardous site wastes. The wastes would have to be analyzed prior to incineration to insure that the wastes cannot be classified as hazardous wastes.</p> <p>If wastes to be incinerated can be classified as hazardous wastes, the requirements of 40 CFR 264.341, 351, and 340 would be applicable.</p>

**Table 5-3
POTENTIAL FEDERAL ACTION-SPECIFIC ARARs FOR MUNICIPAL LANDFILL SITES**

Actions	Requirements	Prerequisites	Citation	Comments
Incineration (Onsite) (cont'd.)	Monitoring of various parameters during operation of the incinerator is required. These parameters include: <ul style="list-style-type: none"> • Combustion temperature. • Waste feed rate. • An indicator of combustion gas velocity. • Carbon monoxide. 		40 CFR 264.343	
Land Treatment	Ensure that hazardous constituents are degraded, transformed, or immobilized within the treatment zone. Maximum depth of treatment zone must be no more than 1.5 meters (5 feet) from the initial soil surface, and more than 1 meter (3 feet) above the seasonal highwater table. Demonstrate that hazardous constituents for each waste can be complete degraded, transformed, or immobilized in the treatment zone. Minimize run-off of hazardous constituents. Maintain run-on/run-off control and management system. Special application conditions if food-chain crops are grown in or on treatment zone. Unsaturated zone monitoring.	RCRA hazardous waste.	40 CFR 264.271 40 CFR 264.271 40 CFR 264.272 40 CFR 264.273 40 CFR 264.273 40 CFR 264.276 40 CFR 264.278	See discussions under Consolidation.
	Special requirements for ignitable or reactive waste. Special requirements for incompatible wastes. Special requirements for RCRA hazardous wastes. Design system to operate odor free.	RCRA waste No's. F020, F021, F022, F023, F026, F027.	40 CFR 264.281 40 CFR 264.282 40 CFR 264.283 CAA Section 101 ^a and 40 CFR 52 ^a	
	File an Air Pollution Emission Notice (APEN) with state to include estimation of emission rates for each pollutant expected. Include with the filed APEN the following: <ul style="list-style-type: none"> • Modeled impact analysis of source emissions. • A Best Available Control Technology (BACT) review for the source operation. 	This additional work and information is normally applicable to sources meeting the "major" criteria and/or to sources proposed for nonattainment areas.	40 CFR 52 ^a 40 CFR 52 ^a	See discussions under Consolidation. See discussions under Consolidation.

**Table 5-3
POTENTIAL FEDERAL ACTION-SPECIFIC ARARs FOR MUNICIPAL LANDFILL SITES**

Actions	Requirements	Prerequisites	Citation	Comments
Land Treatment (cont'd.)	<p>Predict total emissions of volatile organic compounds (VOCs) to demonstrate emissions do not exceed 450 lb/hr, 3,000 lb/day, 10 gal/day, or allowable emission levels from similar sources using Reasonably Available Control Technology (RACT).</p> <p>Verify through emission estimates and dispersion modeling that hydrogen sulfide emissions do not create an ambient concentration greater than or equal to 0.10 ppm.</p> <p>Verify that emissions of mercury, vinyl chloride, and benzene do not exceed levels expected from sources in compliance with hazardous air pollution regulations.</p>	<p>Source operation must be in an ozone nonattainment area.</p>	<p>40 CFR 52^a</p> <p>40 CFR 61^a</p> <p>40 CFR 61^a</p>	<p>See discussions under Consolidation.</p> <p>See discussions under Consolidation.</p> <p>See discussion under Consolidation.</p>
Operation and Maintenance (O&M)	<p>Post-closure care to ensure that site is maintained and monitored.</p>		<p>40 CFR 264.118 (RCRA, Subpart G)</p>	<p>Post-closure requirements for operation and maintenance of municipal landfill sites are relevant and appropriate to new disposal units with nonhazardous waste, or existing units capped in-place.</p> <p>In cases where municipal landfill site wastes are determined to be hazardous wastes, and new disposal units are created, the post-closure requirements will be applicable.</p>
Removal	<p>General performance standard requires minimization of need for further maintenance and control; minimization or elimination of post-closure escape of hazardous waste, hazardous constituents, leachate, contaminated runoff, or hazardous waste decomposition products.</p> <p>Disposal or decontamination of equipment, structures, and soils.</p> <p>Removal or decontamination of all waste residues, contaminated containment system components (e.g., liners, dikes), contaminated subsoils, and structures and equipment contaminated with waste and leachate, and management of them as hazardous waste.</p> <p>Meet health-based levels at unit.</p> <p>RCRA hazardous wastes are subject to land disposal restrictions. Land disposal restrictions set performance requirements on treatment of the wastes before land disposal. The effective date for final group of RCRA wastes is May 8, 1990. Extensions to the effective dates have been granted for specific RCRA wastes that are contained in soil and/or debris.</p>	<p>Disturbance of RCRA hazardous waste (listed or characteristic) and movement outside the unit or area of contamination.</p> <p>May apply to surface impoundment or to contaminated soil, including soil from dredging or soil disturbed in the course of drilling or excavation and returned to land.</p> <p>Not applicable to undisturbed material.</p> <p>Disposal of RCRA hazardous waste (listed or characteristic) after disturbance and movement outside the unit or area of contamination.</p> <p>Management of listed hazardous waste.</p>	<p>40 CFR 264.111</p> <p>40 CFR 264.111</p> <p>40 CFR 264.228(a)(1) and 40 CFR 254.258</p> <p>40 CFR 244.111</p> <p>40 CFR 268</p>	<p>Clean closure removal of contaminated materials does not appear to be feasible for municipal landfill sites in general due to the lack of suitable offsite treatment or disposal facilities to accept the large volume of wastes typically found at municipal landfill sites and the impossibility of meeting the requirement at a site with contaminated groundwater. However, clean closure removal may be considered for portions (hot spots) of municipal landfill sites. The RCRA clean closure requirements would be considered relevant and appropriate to contaminated wastes which are not hazardous, but which are similar to hazardous wastes.</p> <p>In the event that the wastes being removed are determined to be hazardous wastes, the requirements of this section would be applicable.</p> <p>If the wastes found at the municipal landfill site are found to be RCRA wastes, the Land Disposal Restrictions will be applicable.</p> <p>If the wastes are not RCRA wastes but contain the same or similar constituents to those in RCRA wastes, then the Land Disposal Restrictions may be relevant and appropriate.</p>

**Table 5-3
POTENTIAL FEDERAL ACTION-SPECIFIC ARARs FOR MUNICIPAL LANDFILL SITES**

Actions	Requirements	Prerequisites	Citation	Comments
Slurry Wall	Excavation of soil for construction of slurry wall may trigger cleanup or land disposal restrictions.	Disposal by disturbance of hazardous waste and moving it outside the unit or area of contamination.	See Consolidation, Excavation in this table.	See discussions under Consolidation and Excavation.
Surface Water Control	Prevent run-on, and control and collect runoff from a 24-hour, 25-year storm (waste piles, land treatment facilities, landfills)	Land-based treatment, storage, or disposal units.	40 CFR 264.251(c)(d) 40 CFR 264.273(c)(d) 40 CFR 264.301(c)(d)	The requirements for control of run-on and run-off will be relevant and appropriate to all remediation alternatives that manage nonhazardous waste and include onsite land-based treatment, storage, or disposal. The requirements will be applicable to any remediation measures that include land-based treatment, storage, or disposal of hazardous wastes.
	Prevent over-topping of surface impoundment.		40 CFR 264.221(c)	This requirement will be relevant and appropriate to the construction and operation of an onsite surface impoundment, or to operation of an existing onsite surface impoundment managing nonhazardous wastes. These requirements would be applicable to the construction or operation of a surface impoundment for the storage or treatment of hazardous waste.
Treatment	Standards for miscellaneous units (long-term retrievable storage, thermal treatment other than incinerators, open burning, open detonation, chemical, physical, and biological treatment units using other than tanks, surface impoundments, or land treatment units) require new miscellaneous units to satisfy environmental performance standards by protection of groundwater, surface water, and air quality, and by limiting surface and subsurface migration.	Use of other units for treatment of hazardous wastes. These units do not meeting the definitions for units regulated elsewhere under RCRA.	40 CFR 264 (Subpart X)	The requirement will be relevant and appropriate to the construction, operation, maintenance, and closure of any miscellaneous treatment unit (a treatment unit that is not elsewhere regulated) constructed on municipal landfill site for treatment and/or disposal of nonhazardous wastes. These requirements would be applicable to the construction and operation of a miscellaneous treatment unit for the treatment and/or disposal of hazardous wastes.
	Treatment of wastes subject to ban on land disposal must attain levels achievable by test demonstrated available treatment technologies (BDAT) for each hazardous constituent in each listed waste.	Effective data for CERCLA actions is November 8, 1988, for F001-F005 hazardous wastes, dioxin wastes, and certain "California List" wastes. Other restricted wastes have different effective dates as promulgated in 40 CFR 268.	40 CFR 268 (Subpart D)	These regulations are applicable to the disposal of any municipal landfill site waste that can be defined as restricted wastes. These requirements are relevant and appropriate to the treatment prior to land disposal of any wastes that contain components of restricted wastes in concentrations that make the site wastes sufficiently similar to the regulated wastes. The requirements specify levels of treatment that must be attained prior to land disposal.
	Prepare fugitive and odor emission control plan for this action		CAA Section 101 ^a and 40 CFR 52 ^a	See discussions under Consolidation.
	File an Air Pollution Emission Notice (APEN) with state to include estimation of emission rates for each pollutant expected.		40 CFR 52 ^a	See discussions under Consolidation.
	Include with the filed APEN the following: • Modeled impact analysis of source emissions. • A Best Available Control Technology (BACT) review for the source operation.	This additional work and information is normally applicable to sources meeting the "major" criteria and/or to sources proposed for nonattainment areas.	40 CFR 52 ^a	See discussions under Consolidation.

**Table 5-3
POTENTIAL FEDERAL ACTION-SPECIFIC ARARs FOR MUNICIPAL LANDFILL SITES**

Actions	Requirements	Prerequisites	Citation	Comments
Treatment (cont'd.)	Predict total emissions of volatile organic compounds (VOCs) to demonstrate emissions do not exceed 450 lb/hr, 3,000 lb/day, 10 gal/day, or allowable emission levels from similar sources using Reasonably Available Control Technology (RACT).	Source operation must be in an ozone nonattainment area.	40 CFR 52 ^a	See discussions under Consolidation.
	Verify through emission estimates and dispersion modeling that hydrogen sulfide emissions does not create an ambient concentration greater than or equal to 0.10 ppm.		40 CFR 61 ^a	See discussions under Consolidation.
	Verify that emissions of mercury, vinyl chloride, and benzene do not exceed levels expected from sources in compliance with hazardous air pollution regulations.		40 CFR 61 ^a	See discussions under Consolidation.
Underground Injection of Wastes and Treated Groundwater	<p>UIC program prohibits:</p> <ul style="list-style-type: none"> • Injection activities that allow movement of contaminants into underground sources of drinking water (USDW) and results in violations of MCLs or adversely affect health. • Construction of new Class IV wells, and operation and maintenance of existing wells. <p>Wells used to inject contaminated groundwater that has been treated and is being reinjected into the same formation from which it was withdrawn are not prohibited if activity is part of CERCLA or RCRA actions.</p>		<p>40 CFR 144.12</p> <p>40 CFR 144.13</p> <p>40 CFR 144.14</p>	
	All hazardous waste injection wells must also comply with the RCRA requirements.		40 CFR 144.16	
Waste Pile	Use liner and leachate collection and removal system.	RCRA hazardous waste, non-containerized accumulation of solid, nonflammable hazardous waste that is used for treatment or storage.	40 CFR 264.251	

Notes:

^a All of the Clean Air Act ARARs that have been established by the federal government may be covered by matching state regulations. The state may have the authority to manage these programs through the approval of its implementation plans (40 CFR 52 Subpart G).

^b Action alternatives from ROD keyword index.

^c Bulk storage requires the preparation and implementation of a spill prevention, control, countermeasures (SPCC) plan (see 40 CFR 761.65(c)(7)(ii) for specification of container sizes that are considered “bulk” storage containers).

^d These regulations apply regardless of whether the remedial action discharges into the sewer or trucks the waste to an inlet to the sewage conveyance system located “upstream” of the POTW.

^e An *approved incinerator* (under Section 761.70) can be used to destroy any concentration of PCBs; a *high-efficiency boiler* approved under Section 761.60(a)(2)(iii) can be used for mineral oil dielectric fluid from PCB-contaminated electrical equipment containing PCBs in concentrations greater than or equal to 50 ppm but less than 500 ppm; and a *RCRA-approved incinerator* (under RCRA paragraph 3005(a)) can be used for PCBs that are not subject to the incinerator requirements of TSCA.

Maximum Contaminant Levels (MCLs). MCLs are enforceable drinking water standards established by U.S. EPA under the Safe Drinking Water Act. MCLs establish the maximum level of a contaminant that is allowed in water delivered to any user of a public water system. An MCL for a specific contaminant is required by law to be set as close as feasible to the maximum contaminant level goal (MCLG) (see Section 5.2.2.1) for the same contaminant, taking into consideration the best technology, treatment techniques, and other factors (including costs).

MCLs, as the enforceable requirements of the SDWA, are potential ARARs pursuant to CERCLA Section 121(d)(2)(A)(i). The NCP further states that MCLs generally have the status of ARARs for groundwater when the MCLGs are not an ARAR and the MCLs are relevant and appropriate under the circumstances of the release. A discussion of this issue can be found on page 8753 of the preamble to the March 8, 1990, final NCP. Typically, MCLs are considered relevant and appropriate to groundwater Class I and II aquifers. Compliance with an ARAR generally would be measured at the landfill boundary (not at the property boundary).

In some cases, a waiver of the MCLs may need to be obtained. As an example, a landfill with waste below the water table may continue to exceed MCLs in groundwater far into the future because of continued leaching of waste. In such cases, groundwater collection and treatment may not achieve MCLs at the landfill boundary, and a waiver for technical impracticality would need to be obtained. A technical impracticality waiver for termination of a groundwater/leachate collection and treatment system is usually available at some extended time in the future for municipal landfill sites in the vent that MCLs are not achievable [SARA 121(d)(4)(C)].

Maximum Contaminant Level Goals (MCLGs). MCLGs are non-enforceable goals for drinking water set by U.S. EPA under the Safe Drinking Water Act. MCLGs represent a contaminant level presenting “no known or anticipated adverse effects on the health of

persons; and allowing for an additional adequate margin of safety beyond that level. MCLGs are listed in 40 CFR 141.50.

Based on the NCP, 40 CFR 300.430(e)(2)(i)(B), MCLGs above zero should be attained by remedial actions for ground or surface water that is a current or potential source of drinking water where the MCLGs are determined to be relevant and appropriate under the circumstances of the release. When the MCLG for a contaminant has been set at zero, the MCL promulgated for that contaminant should be attained for current or potential sources of drinking water, where the MCL is relevant and appropriate. In cases where ARARs (for example, MCLs, MCLGs) are not available for a particular contaminant, or in cases where ARARs are not sufficiently protective (e.g., because of multiple contaminants), remediation goals should be based on a risk assessment where acceptable exposure levels generally are concentrations that represent an excess upper bound lifetime cancer risk to an individual of between 10^{-4} and 10^{-6} .

Secondary Maximum Contaminant Levels. Secondary MCLs are non-enforceable goals for drinking water established by EPA under the Safe Drinking Water Act. Secondary MCLs pertain to contaminants that, if present in excessive quantities, may discourage the utilization of a public water supply because they affect qualities such as taste, color, odor, and corrosivity. Secondary MCLs are TBCs and are listed in 40 CFR 143. In many cases, exceedance of secondary MCLs is the first indication of a more serious problem with a drinking water source.

Federal Water Quality Criteria (FWQC). FWQCs are non-enforceable guidelines developed by EPA under the Clean Water Act. However, they are potential ARARs because SARA and the NCP state that FWQC shall be attained “where relevant and appropriate under the circumstances of the release” (CERCLA Section 121(d)(2)(B); 40 CFR 300.430(e)(2)(i)(E)). Two types of criteria have been set by EPA, one for the protection of human health and another for the protection of aquatic life. FWQCs set quantitative levels of

pollutants in water, the levels such that water quality is adequate for a specified use. These levels are based solely on data and scientific judgments regarding the relationship between concentrations of a pollutant and resulting effects on environmental and human health. FWQCs do not reflect consideration of economic or technological feasibility. FWQCs are used by the states to set their own water quality standards for surface water. They are also typically used by state and federal agencies in setting National Pollution Discharge Elimination System (NPDES) discharge permit levels.

Whether a water quality criterion is relevant and appropriate depends on the designated or potential water uses, the environmental media affected, the purpose for which such criteria were developed, and the latest available scientific information available (see CERCLA Section 121(d)(2)(B)(i)). Although a state may develop its own use classification scheme, designated uses generally include recreation, protection, and propagation of fish and aquatic life; agricultural and industrial uses; public water supply; and navigation.

For water designated as a public water supply, MCL/MCLGs would generally be relevant and appropriate; the criteria that reflect fish consumption may also be relevant and appropriate if fishing is included in the state's designated use. If the state has designated a water body for recreation, a water quality criteria reflecting fish consumption alone may be relevant and appropriate if fishing is included in the recreational use designation. Generally, water quality criteria are not relevant and appropriate for other uses, such as industrial or agricultural, since exposure reflected in the water quality criteria are not likely to occur. The two types of FWQC are discussed below:

- **FWQCs for Human Health Protection:** One goal of the FWQC is to protect humans from hazards associated with two routes of exposure, including exposure from drinking the water and exposure from consuming aquatic organisms, primarily fish. There are nonbinding guidelines provided that address exposure from both routes, and from fish consumption alone. The criteria identify concentrations

equating to specified levels of cancer risk (10^{-5} , 10^{-6} , and 10^{-7}) for carcinogens or threshold-level concentrations for noncarcinogens that represent the water concentrations at which there would be no chronic adverse health effects. There are also criteria for chemicals with organoleptic properties (that is, affecting taste or odor but not health). These criteria are based on concentrations at which there would be no taste or odor problems. The FWQC values for human health protection can be found in the Federal Register, Vol. 45 (No. 231), FR pg. 79318, November 29, 1980--Water Quality Criteria.

- **FWQCs for Aquatic Life Protection:** The FWQC criteria for the protection of aquatic life present two sets of values, one based on the protection of aquatic life from acute exposure and the other from chronic exposures. When data are not sufficient to set a criterion, the lowest reported acute or chronic-effects level published in the literature is used. A summary of water quality criteria may be found in *Quality Criteria for Water* (U.S. EPA, 1986aa), which is commonly referred to as the "Gold Book."

Office Of Drinking Water Health Advisories.

The health advisories are non-enforceable guidelines (TBCs) that present the EPA Office of Water's most recent determination regarding the concentration level of drinking water contaminants below which adverse effects would not be anticipated to occur. This level includes a margin of safety to protect sensitive members of the population and is subject to change as new health information becomes available. Levels are specified for 1-day, 10-day, longer term (e.g., 10 percent of one's lifetime, 7 years), and lifetime exposure periods.

5.2.1.2 Location-Specific ARARs

Location-specific ARARs are the restrictions placed on the concentration of hazardous substances or the conduct of activities solely because they occur in special locations. These

requirements relate to the geographical or physical position of municipal landfill sites rather than to the nature of the contaminants or the proposed remedial actions. These requirements may limit the type of remedial action that can be implemented and may impose additional constraints on the cleanup action. The restrictions caused by flood plains and wetlands are among the most common location-specific potential ARARs for municipal landfill sites. Federal location-specific ARARs for municipal landfill sites are presented in Table 5-2, at the end of this section. The following is a discussion of the location-specific ARARs that typically are most pertinent to landfill sites.

Wetlands. Remediation of municipal landfill sites located next to wetland areas will have to be implemented in a manner which minimizes the destruction, loss or degradation of wetlands (40 CFR 6.302(a)). Additionally, the Clean Water Act Section 404 prohibits discharge of dredged or fill material into a wetland area. Situations where wetlands are filled or have been irreparably harmed may require the creation of new wetlands. Information on the Corps of Engineers methodology for identifying and evaluating wetland areas can be found in the document *Wetland Evaluation Technique (WET)* (U.S. Army Corps of Engineers, 1987).

Floodplains. Remediation of landfill sites located within floodplains (for example, lowlands, and relatively flat areas adjoining inland and coastal waters) will have to be carried out to the extent possible, to avoid adverse effects, and to preserve natural and beneficial values of the floodplain (40 CFR 6.302(b)). For example, remedial actions should not be designed and constructed in a manner that destroys the usefulness of a floodplain, thereby potentially causing adjacent areas to become flooded.

5.2.1.3 Action-Specific ARARs

Action-specific ARARs are usually technology- or activity-based requirements or limitations on actions taken with respect to hazardous substances. These requirements typically define

acceptable treatment, storage, and disposal procedures for hazardous substances during the implementation of the response action. The requirements generally set performance or design standards for specific activities related to managing hazardous wastes at municipal landfill sites. Action-specific ARARs for municipal landfill sites are shown in Table 5-3, located at the end of this section. The following is a discussion of the action-specific ARARs that typically are most pertinent to landfill sites.

RCRA Closure Requirements. A determination must be made on which RCRA closure requirements are applicable or relevant and appropriate for the specific site of concern. RCRA Subtitle D requirements are generally applicable unless a determination is made that Subtitle C is applicable or relevant and appropriate. RCRA Subtitle C would be applicable if the waste is a listed or characteristic waste under RCRA, *and* (1) if the waste was disposed of after November 19, 1980 (effective date of RCRA) or (2) the response action constitutes current treatment, storage, or disposal as certified by RCRA. The decision about whether a RCRA requirement is relevant and appropriate is based on consideration of a variety of factors, including the nature of the waste and its hazardous properties, and the nature of the requirement itself. State closure requirements that are an ARAR and that are more stringent than the federal requirements must be attained (or waived). Listed hazardous wastes are found in 40 CFR Part 261, Subpart D. Characteristic hazardous wastes under RCRA are described in 40 CFR Part 261, Subpart C.

Because containment of landfill wastes is a common element of most remedial actions at municipal landfill sites, the most significant closure requirements will likely be the RCRA requirements concerning landfill covers. RCRA Subtitle C closure requirements specify that a landfill cover for a permitted facility have a permeability less than or equal to the permeability of any bottom liner system or natural subsoils present (40 CFR 264.310). Additional information on landfill covers can be found in Section 4 of this document.

Land Disposal Restrictions. Offsite disposal of contaminated soils from hot spots may be a viable component of a remedial action alternative for a municipal landfill site. In situations where the material is regulated as hazardous under RCRA Subpart C, land disposal of contaminated soils offsite will be based largely on the RCRA Land Disposal Restrictions (LDRs). The LDRs may be applicable to the contaminated soils if it is determined that the soils have been contaminated by a restricted, listed RCRA waste or if the contaminated soils are a RCRA characteristic waste. The LDRs may require that a specific concentration level be achieved or that a specified technology be used for treatment prior to land disposal in a RCRA facility. Treatment of hot spots and subsequent disposal may also trigger LDRs.

If soils contain RCRA waste, offsite land disposal must be at a permitted RCRA hazardous waste landfill that meets the requirements of RCRA Subtitle C, that is in compliance with CERCLA Section 121(d)(3) and the Superfund offsite policy. The design features of a RCRA hazardous waste landfill are defined in 40 CFR 254 Subpart N. If the soils are not a RCRA waste or if they are delisted, offsite disposal may be at a solid waste landfill that is in compliance with the offsite policy and CERCLA Sec. 121(d)(3). In the absence of other regulations, solid waste landfills are regulated under RCRA Subtitle D. However, in most cases, state regulations govern the design, construction, operation, and closure of solid waste landfills.

Air Emission Treatment Requirements. Several alternatives for remediation of landfill sites may include technologies that result in a discharge of contaminants to the air. Table 5-3 presents a summary of the federal requirements concerning air emissions for technologies commonly implemented at municipal landfill sites. The need for air emission treatment should be evaluated based on federal and state requirements and an evaluation of human health risks. Technologies that typically result in air emissions include air stripping, collection and treatment of landfill gas, excavation and consolidation of contaminated soils, and incineration.

The EPA Office of Air Quality, Planning, and Standards is currently developing new source emission guidelines and performance standards for collection and treatment of landfill gas. The proposed rule (a TBC) would require an active landfill gas collection and control system for solid waste landfills with emissions exceeding 100 megagrams per year of nonmethane organic compounds. Treatment of landfill gas (e.g., by enclosed ground flares) would be required to demonstrate a destruction removal efficiency of 98 percent or emissions less than or equal to 20 ppm (volume dried) of nonmethane organic compounds. Since these emission guidelines and standards are currently under development, some changes may be made.

The proposed air emission standards will apply to new municipal solid waste landfills as well as to those facilities that have accepted waste since November 8, 1987, or that have capacity available for future use. For CERCLA municipal landfill remediations, these requirements would be potential ARARs for all records of decision (RODs) signed after the rule's promulgation date. The standards in this rule, once promulgated, will be applicable for those municipal landfill sites on the NPL that accepted waste on or after November 8, 1987, or that are operating and have capacity for future use. In cases where these standards are not applicable, such as landfill sites that accepted waste prior to November 8, 1987, they may still be determined to be relevant and appropriate. The determination of relevance and appropriateness is made on a site-specific basis pursuant to NCP Section 300.400(g) (55 Federal Register 8841, March 8, 1990). Judgment should be used in applying these guidelines and standards since they will apply to municipal solid waste landfills as opposed to CERCLA sites where there is typically co-disposal of both municipal solid waste and hazardous waste.

5.2.2 State ARARs

In general, in order for a state requirement to be considered an ARAR, it must:

- Be promulgated (be legally enforceable and of general applicability)

- Be identified to EPA in a timely manner
- Not result in an in-state ban on land disposal of hazardous waste
- Be more stringent than federal requirements

Even if the state standard meets these conditions, it may be waived if it is found not to have been applied uniformly and consistently throughout the state.

Because many states may be revising their standards in any given year, more stringent state standards for municipal landfill sites need to be identified on a case-by-case basis. The aspects of state requirements that are likely to be more stringent are described below.

5.2.2.1 Chemical-Specific ARARs

State Drinking Water Acts. Many states administer drinking water acts that contain chemical-specific standards and criteria that are often ARARs for groundwater remediation. A review of state standards should be conducted to see if any standards or criteria (such as drinking water action levels) exist that are more stringent than federal standards (for example, MCLs and MCLGs). For cases where a more stringent state standard exists for a particular compound, the state standard should be used, where relevant and appropriate under the circumstances of the release (most drinking water standards are not legally “applicable” to groundwater). In addition, states often have health advisories that are more stringent than federal criteria. These TBCs may be considered as well.

Clean Water Act. Many states administer the federal Clean Water Act and its important component, the NPDES program, which contains standards and criteria for discharge of treated waters to nearby surface waters (see Section 5.2.2.3).

5.2.2.2 Location-Specific ARARs

Wetlands. State requirements for designation of

wetlands should be reviewed to determine if they are more stringent than the Corps of Engineers’ methodology. Stringent state methodologies for identifying wetlands can expand the extent of wetlands requiring mitigation. In cases where wetlands have been contaminated or destroyed, mitigation measures may need to be included in the remedial action. State requirements can differ significantly from federal regulations.

Floodplains. State ARARs often prohibit the siting of landfills in floodplains, which in turn may restrict onsite disposal options.

5.2.2.3 Action-Specific ARARs

NPDES Program. Pretreatment requirements for discharge directly to a publicly owned treatment works (POTW) under the NPDES program may be dictated by a local or regional government agency. A careful review of a state’s NPDES requirements and of the potential pretreatment requirements that would be imposed by the POTW is therefore necessary. Frequently, discussions on the acceptability of a discharge to a POTW will extend well into the predesign and design phases at Superfund sites. There is also a tendency for POTW permitting authorities to set stringent discharge standards because there is no categorical standard for CERCLA operations and because of public fear or mistrust of “hazardous waste.”

Direct discharge of treated effluent offsite to a surface water body would also require an NPDES discharge permit. In many cases EPA has delegated implementation of this program to the states. Therefore, as with discharge to a POTW, a review of a state’s NPDES requirements should be conducted if direct discharge offsite to a surface water is being considered.

Closure Requirements. State requirements for cover of hazardous and solid waste landfills should be reviewed to determine whether more stringent design criteria exist for the construction, operation, and closure of landfills. The state may also have erosion and sedimentation control regulations. Local requirements (e.g., erosion control regulations) and closure requirements such as minimum standards for cover designs may be important TBC material

although they are generally not ARARs (unless they represent the state standards).

Air Emission Treatment Requirements. As with the water programs, many states administer the Clean Air Act (CAA). State air emission standards should be reviewed for technologies such as incineration or air stripping to see if requirements more stringent than federal CAA requirements exist. Landfill gas emissions may also be regulated Under state air regulations.

5.3 Long-Term Effectiveness and Permanence

Some aspects of long-term effectiveness include the ability of a cap to maintain its integrity, the ability of groundwater extraction to meet cleanup levels, and the long-term maintainability of leachate or gas treatment systems. Long-term effectiveness also includes an evaluation of the magnitude of residual risk. Because the technologies generally considered practicable for municipal landfill sites will not completely eliminate the hazardous substances at a landfill, long-term management of waste is a critical issue. Complete evaluation under this criterion should require determining the risk posed by the remaining waste. One of the more time-consuming tasks associated with the evaluation under this criterion may be the need to estimate infiltration through an existing or new landfill cap. Groundwater and air modeling also may be needed. EPA's computer model HELP (hydrologic evaluation of landfill performance), which is discussed in Section 4.2 (Landfill Contents), may be useful in evaluating this criteria.

5.4 Reduction of TMV Through Treatment

Generally, reduction of TMV at municipal landfill sites occurs through treatment of hot spots. However, TMV can also be reduced through treatment of groundwater, leachate, or landfill gas. When treatment is used, a number of factors must be considered. Naturally, the treatment process

used and the materials treated must be evaluated. This evaluation can be particularly significant for innovative technologies or conventional technologies being applied to a waste that has unusual characteristics. The volume of material destroyed or treated must be evaluated, as well as the degree of expected reductions. Also, the degree to which treatment is irreversible must be considered, particularly for technologies like stabilization. Technologies such as capping and fencing that provide no treatment do not require evaluation under this criterion.

5.5 Short-Term Effectiveness

A significant issue of short-term effectiveness is the effect on the community of truck traffic as large quantities of cap material are hauled onto the site. Both noise and potential increases in vehicular accidents must be considered (construction of a typical 40-acre multilayer cap requires about 32,500 truckloads of capping material). Other issues such as potential VOC emissions during excavation of hot spots and during construction and operation of onsite treatment systems are associated with worker and community protection during remedial activities. Also included under this criterion are the environmental impacts resulting from the remedial action. To evaluate this criterion, the time required to achieve the response objectives must be determined, including an estimate of time to achieve remediation of leachate and groundwater.

5.6 Implementability

Administrative implementability is the relative difficulty of coordinating and obtaining approvals from other agencies to perform certain activities. The difficulty of meeting this subcriterion will vary from site to site, and depends primarily on the location of the site and what other agencies are involved. There may be significant administrative implementability issues associated with offsite deed restrictions and alternative water supplies. The enforceability of deed restrictions tends to vary greatly, depending on local laws and ordinances. Likewise, the administrative implementability of

treating leachate or groundwater at a POTW depends on how receptive local treatment plant officials are to accepting contaminated water from the site. It is not uncommon for discussions with POTWs to extend well into the remedial design phase.

The technical implementability of a technology, including the ability to construct and/or operate the technology, and the reliability of the technology, largely depends on the treatability of the contaminated material. For example, technical difficulties are likely when using incineration for wastes that are high in metals, or when using in situ stabilization for wastes containing moderate to high levels of organics. The technical implementability of some technologies would also depend on availability of sufficient space for the materials-handling and/or equipment. Also, the ability to monitor the effectiveness of a remedy is a consideration, particularly for a technology like in situ stabilization. The ease of undertaking additional remedial actions, if necessary, must also be considered. The treatment technologies that have been identified as being most practicable for municipal landfill sites are proven conventional technologies (a few innovative technologies have also been discussed).

The availability of goods and services will also vary from site to site and will depend primarily on a site's location and accessibility. As an example, the implementability of bringing in truckloads of fill material will depend on the source of the material and the accessibility to the site.

5.7 Cost

In Table 5-1, an indication is given of whether each technology will have a low, medium, or high impact on total cost if included as part of an alternative. Costs can be difficult to estimate for groundwater extraction and treatment and for hot spot excavation and/or treatment because the volume of

contaminated groundwater and hot spots is difficult to estimate accurately during the RI/FS. FS cost estimates should provide an accuracy of +50 percent to -30 percent using data available from the RI.

5.8 State Acceptance

Under this criterion, an alternative is evaluated in terms of the technical and administrative issues and concerns the state (or support agency) may have. This is a criterion that is addressed in the record of decision (ROD) once formal comments are received on the RI/FS report (to the extent they are known, state concerns are considered earlier in the process as well). Frequently, state acceptance is closely related to compliance with state ARARs.

5.9 Community Acceptance

Under this criterion, an alternative is evaluated in terms of the issues and concerns the public may have. As with state acceptance, this is a criterion that is addressed in the ROD once the comments have been formally received on the RI/FS report (also, to the extent they are known, community concerns are considered early in the process as well).

5.10 Section 5 Summary

This section presents each of the evaluation criteria and illustrates how each of the technologies identified in Section 4 may affect each of the alternative evaluation criteria. In the following section, alternatives typically developed for a municipal landfill site are presented. The section describes how the technologies discussed in this section (Table 5-1) might be combined and then evaluated as alternatives using the nine criteria.

Section 6

DEVELOPMENT AND EVALUATION OF ALTERNATIVES FOR THE EXAMPLE SITE

Based on the review of practicable technologies for municipal landfill sites (see Section 4) and the actual characteristics of the example site (see Appendix A), a range of typical alternatives has been developed. The purpose is to illustrate how technologies might be combined to form alternatives typically developed for landfill sites. Some components of these alternatives may not be applicable to other sites, depending on their specific characteristics. Table 6-1 presents an evaluation of each alternative with respect to the threshold criteria, overall protection of human health and the environment, and compliance with ARARs and the five balancing criteria described in Section 5. The modifying criteria, state acceptance, and community acceptance are not included in Table 6-1 since they are not formally evaluated during the FS. These two criteria are addressed in the Record of Decision (ROD) and are used as a basis for modifying an alternative due to formal comments from the state or community on the FS report and proposed plan. Addressing state and community concerns is incorporated throughout the RI/FS process; formal use of the modifying criteria once the proposed plan has been issued is not the first time these concerns are addressed.

The example site, considered a co-disposal facility with a known hot spot, is described in Appendix A--Site Characterization Strategy for an Example Site. To summarize, the site is approximately 60 acres in size (20 acres of which is a landfill) and is in a rural area. In addition to municipal trash, the landfill accepted chemical wastes such as solvents, paint, paint thinners and lacquers, and industrial plating sludges. Available records show no indication of segregation of wastes. Industrial, commercial, and municipal wastes are generally mixed throughout the landfill, except for liquid industrial solvent wastes. Disposal of this waste was generally restricted to the southern portion of

the landfill. Exposed areas in the southern half of the landfill have been temporarily covered with a partial cap consisting of 2 feet of compacted clay. The remainder of the landfill has a temporary soil cover, although there are some areas of exposed wastes.

The unconsolidated deposits underlying the site are approximately 135 feet thick and consist primarily of sand and gravel of glaciofluvial and alluvial origin. Bedrock in the vicinity of the site, encountered at an approximate depth of 135 feet, consists of undifferentiated Cambrian sandstone up to 1,200 feet thick. These sandstones are fine to coarse grained and contain a small amount of shale.

Some of the contaminants of concern are trichloroethene (TCE) and vinyl chloride (VC) in the soil and groundwater; lead, arsenic, and total chromium in the soil; and methane gas.

The areas of concern for the example site include:

- Landfill contents under the existing soil cover
- The hot spot outside the existing soil cover
- High-strength (onsite) groundwater (leachate)
- Low-strength (offsite) groundwater
- Surface water sediments (from a nearby unnamed tributary)
- Landfill gas

The ARARs for the Example Site are discussed below:

**Table 6-1
RECOMMENDED ALTERNATIVES: SUMMARY OF DETAILED ANALYSIS
EXAMPLE SITE**

	Alternative 1	Alternative 2	Alternative 3	Alternative 4
	No Action	Single-Barrier Cap Consolidation of Hot Spot High-Strength Groundwater (Leachate) Collection and Onsite Treatment Low-Strength Groundwater Extraction and Onsite Treatment Discharge to Unnamed Tributary Consolidation of Surface Water Sediments Institutional Controls Five-Year Review	Composite-Barrier Cap Consolidation of Hot Spot High-Strength Groundwater (Leachate) Collection and Onsite Treatment Low-Strength Groundwater Extraction and Onsite Treatment Discharge to Unnamed Tributary Consolidation of Surface Water Sediments Institutional Controls Five-Year Review	Single-Barrier Cap Treatment of Hot Spot (onsite) High-Strength Groundwater (Leachate) Collection and Onsite Treatment Low-Strength Groundwater Extraction and Onsite Treatment Discharge to Unnamed Tributary Consolidated of Surface Water Sediments Institutional Controls Five-Year Review
Evaluation Criteria				
Overall Protection of Human Health and the Environment	No action taken. Not considered to be protective of human health and the environment	Construction of a cap reduces the risk of exposure to the landfill contents, and reduces leaching of contaminants to the groundwater. Institutional controls and monitoring of groundwater quality will be required during aquifer restoration to protect public health and the environment.	A composite-barrier cap will be more reliable than a single-barrier cap in terms of preventing direct contact with landfill contents and reducing infiltration. Institutional controls will still be required during the period of aquifer restoration for protection of public health and the environment.	Treatment of hot spots provides additional protection to human health and the environment by reducing the volume of contamination at the site. As with Alternative 2 and Alternative 3, institutional controls will still be required during the period of aquifer restoration to prevent the use of contaminated groundwater.
Compliance with ARARs	No action taken. Not considered to be in compliance with ARARs.	Expected to be in compliance with ARARs.	Expected to be in compliance with ARARs.	Expected to be in compliance with ARARs.
Long-Term Effectiveness				
<ul style="list-style-type: none"> Magnitude of Residual Risk 	Existing infiltration through cap will continue. Infiltration allows leaching of contaminants to groundwater. Risks from direct contact will also remain.	Reduction of residual risk from direct contact. Lessens future potential for groundwater contamination by reducing infiltration. The groundwater is collected and treated; however, the source of contamination remains, presenting a possible future risk that contamination will breach the containment system.	Potential for infiltration is reduced over single-barrier cap protection. The groundwater is collected and treated; however, the source of contamination remains, presenting a possible future risk that contamination will breach the containment system.	Less residual waste onsite to manage since hot spots will be excavated and incinerated and the groundwater will be collected and treated. Excavation may reduce long-term risk. The groundwater is collected and treated; however, a portion of the source of contamination remains, presenting possible future risk that contamination will breach the containment system.
<ul style="list-style-type: none"> Adequacy and Reliability of Controls 	Continued erosion of existing cap likely to occur. Wastes could eventually be exposed with potential for exposure onsite or transport of contaminants in runoff to wetlands.	Improved reliability over no action. Requires long-term maintenance to maintain the integrity of the cap.	Increased reliability over the single-barrier cap. Synthetic liner provides an additional barrier for reducing infiltration and leachate generation resulting from infiltration. Potential for rupture of synthetic liner from differential settling. Requires long-term maintenance to maintain the integrity of the cap.	Provides the greatest long-term effectiveness and permanence since hot spots will be treated. Continued maintenance will be required to maintain the integrity of the cap.

**Table 6-1
RECOMMENDED ALTERNATIVES: SUMMARY OF DETAILED ANALYSIS
EXAMPLE SITE**

	Alternative 1	Alternative 2	Alternative 3	Alternative 4
	No Action	Single-Barrier Cap Consolidation of Hot Spot High-Strength Groundwater (Leachate) Collection and Onsite Treatment Low-Strength Groundwater Extraction and Onsite Treatment Discharge to Unnamed Tributary Consolidation of Surface Water Sediments Institutional Controls Five-Year Review	Composite-Barrier Cap Consolidation of Hot Spot High-Strength Groundwater (Leachate) Collection and Onsite Treatment Low-Strength Groundwater Extraction and Onsite Treatment Discharge to Unnamed Tributary Consolidation of Surface Water Sediments Institutional Controls Five-Year Review	Single-Barrier Cap Treatment of Hot Spot (onsite) High-Strength Groundwater (Leachate) Collection and Onsite Treatment Low-Strength Groundwater Extraction and Onsite Treatment Discharge to Unnamed Tributary Consolidated of Surface Water Sediments Institutional Controls Five-Year Review
Evaluation Criteria				
Reduction of Toxicity, Mobility, and Volume				
! Treatment Process Used and Materials Treated	A treatment technology is not included as part of this alternative.	Conventional treatment of groundwater including metals precipitation, biological treatment (activated sludge), GAC.	Conventional treatment of groundwater including metals precipitation, biological treatment (activated sludge), GAC.	Hot spots to be treated onsite via incinerator. Same as Alternative 2 and 3 for groundwater treatment.
! Amount of Hazardous Materials Destroyed or Treated	A treatment technology is not included as part of this alternative.	High-strength groundwater (leachate) collected from perimeter wells will be treated, primarily to prevent offsite migration of contaminated groundwater. Offsite groundwater will be collected and treated. The rate of hazardous materials destroyed will depend on the extraction rate (that is, whether a high or low flow rate is selected).	High-strength groundwater (leachate) and low strength groundwater (offsite) will be collected and treated. The amount of hazardous materials destroyed will depend on the extraction rate (that is, whether a high or low flow rate is selected).	Reduction in the hazardous organic constituents would be achieved by incineration of hot spots. Same as Alternative 2 and 3 for groundwater.
! Expected Reductions in Toxicity, Mobility, and Volume	A treatment technology is not included as part of this alternative.	Toxicity or volume of contaminated groundwater may be reduced by treatment system.	Toxicity or volume of high strength groundwater may be reduced by treatment system.	TMV would be reduced through the treatment of hot spot areas. Same as Alternative 2 and 3 for groundwater.
! Irreversibility of the Treatment	A treatment technology is not included as part of this alternative.	Groundwater treatment process may not be irreversible.	Groundwater treatment process may not be irreversible.	Incineration is permanent. Same as Alternative 2 and 3 for groundwater.
! Type and Quantity of Treatment Residual	A treatment technology is not included as part of this alternative.	Sludge from metals precipitation process may need to be disposed of at a RCRA landfill.	Sludge from metals precipitation process may need to be disposed of at a RCRA landfill.	Ash from incinerator will be placed under cap. Same as Alternative 2 and 3 for groundwater residuals.

**Table 6-1
RECOMMENDED ALTERNATIVES: SUMMARY OF DETAILED ANALYSIS
EXAMPLE SITE**

	Alternative 1	Alternative 2	Alternative 3	Alternative 4
	No Action	Single-Barrier Cap Consolidation of Hot Spot High-Strength Groundwater (Leachate) Collection and Onsite Treatment Low-Strength Groundwater Extraction and Onsite Treatment Discharge to Unnamed Tributary Consolidation of Surface Water Sediments Institutional Controls Five-Year Review	Composite-Barrier Cap Consolidation of Hot Spot High-Strength Groundwater (Leachate) Collection and Onsite Treatment Low-Strength Groundwater Extraction and Onsite Treatment Discharge to Unnamed Tributary Consolidation of Surface Water Sediments Institutional Controls Five-Year Review	Single-Barrier Cap Treatment of Hot Spot (onsite) High-Strength Groundwater (Leachate) Collection and Onsite Treatment Low-Strength Groundwater Extraction and Onsite Treatment Discharge to Unnamed Tributary Consolidated of Surface Water Sediments Institutional Controls Five-Year Review
Evaluation Criteria				
Short-Term Effectiveness				
! Protection of Community during Remedial Action	Not action taken.	Possible impacts from consolidation activities. Community impact through increased dust and noise from construction and truck traffic. Truck traffic introduces risk from vehicular accidents.	Possible impacts from consolidation activities. Community impact through increased dust and noise from construction and truck traffic. Truck traffic introduces risk from vehicular accidents.	Possible impacts from disturbance of waste and improper air emissions. Adverse impacts to air quality from malfunctions of incinerator and poor destruction efficiency could also be expected. Community impact through increased dust and noise from construction and truck traffic. Truck traffic introduces risk from vehicular accidents.
! Protection of Workers during Remedial Action	None required.	Potential risk to workers through inhalation and direct contact during grading and excavation of hot spots. Proper dust control and health and safety protection will mitigate risk.	Potential risk to workers through inhalation and direct contact during grading and excavation of hot spots. Proper dust control and health and safety protection will mitigate risk.	Greatest potential for safety-related problems because it involves the excavation of contaminated materials. Direct exposure and inhalation is the safety risk to workers. Although detailed planning, design, and implementation can minimize the potential safety problems to onsite and offsite personnel, they cannot be totally eliminated.
! Environmental Impacts	No remedial action.	Potential for exposure to waste or runoff of contaminants to Polk River during implementation. Potential negative impact from possible secondary migration of contaminated surface water sediments during removal for consolidation under cap.	Potential for exposure to waste or runoff of contaminants to Polk River during implementation. Potential negative impact from possible secondary migration of contaminated surface water sediments during removal for consolidation under cap.	Potential negative impact due to air emissions from incineration. Potential for exposure to waste or runoff of contaminants to Polk River during implementation.

**Table 6-1
RECOMMENDED ALTERNATIVES: SUMMARY OF DETAILED ANALYSIS
EXAMPLE SITE**

	Alternative 1	Alternative 2	Alternative 3	Alternative 4
	No Action	Single-Barrier Cap Consolidation of Hot Spot High-Strength Groundwater (Leachate) Collection and Onsite Treatment Low-Strength Groundwater Extraction and Onsite Treatment Discharge to Unnamed Tributary Consolidation of Surface Water Sediments Institutional Controls Five-Year Review	Composite-Barrier Cap Consolidation of Hot Spot High-Strength Groundwater (Leachate) Collection and Onsite Treatment Low-Strength Groundwater Extraction and Onsite Treatment Discharge to Unnamed Tributary Consolidation of Surface Water Sediments Institutional Controls Five-Year Review	Single-Barrier Cap Treatment of Hot Spot (onsite) High-Strength Groundwater (Leachate) Collection and Onsite Treatment Low-Strength Groundwater Extraction and Onsite Treatment Discharge to Unnamed Tributary Consolidated of Surface Water Sediments Institutional Controls Five-Year Review
Evaluation Criteria				
Short-Term Effectiveness (continued) <ul style="list-style-type: none"> Time Until Remedial Action Objectives are Achieved 	No time requirements.	Less than 2 years should be required to implement components of the remedy. If a low flow extraction rate (e.g., 200 gpm) is selected the goal for achieving groundwater remediation would be 15 years. If a high flow extraction rate (e.g., 500 gpm) is selected the goal for achieving groundwater remediation would be 5 years. This assumes continued collection of leachate and a completely effective leachate collection system controlling offsite migration of contaminated groundwater.	Less than 2 years should be required to implement components of remedy. Goal for achieving remediation is the same as Alternative 2.	Groundwater remediation will be the same as Alternative 2. However, incineration of hot spots and dredging of surface water sediments will require additional time to implement the source control components of this remedy. The source control components should be implemented in less than 4 years.

**Table 6-1
RECOMMENDED ALTERNATIVES: SUMMARY OF DETAILED ANALYSIS
EXAMPLE SITE**

	Alternative 1	Alternative 2	Alternative 3	Alternative 4
	No Action	Single-Barrier Cap Consolidation of Hot Spot High-Strength Groundwater (Leachate) Collection and Onsite Treatment Low-Strength Groundwater Extraction and Onsite Treatment Discharge to Unnamed Tributary Consolidation of Surface Water Sediments Institutional Controls Five-Year Review	Composite-Barrier Cap Consolidation of Hot Spot High-Strength Groundwater (Leachate) Collection and Onsite Treatment Low-Strength Groundwater Extraction and Onsite Treatment Discharge to Unnamed Tributary Consolidation of Surface Water Sediments Institutional Controls Five-Year Review	Single-Barrier Cap Treatment of Hot Spot (onsite) High-Strength Groundwater (Leachate) Collection and Onsite Treatment Low-Strength Groundwater Extraction and Onsite Treatment Discharge to Unnamed Tributary Consolidated of Surface Water Sediments Institutional Controls Five-Year Review
Evaluation Criteria				
Implementability				
<p>! Technical Feasibility</p> <ul style="list-style-type: none"> - Ability to construct and operate technology - Reliability of technology - Ability to monitor effectiveness of remedy - Ease of undertaking additional remedial action, if any <p>! Availability of Services and Materials</p>	<p>No action taken.</p> <p>Not applicable.</p>	<p>Relatively easy to implement. Implementation of this alternative uses conventional equipment and technologies.</p> <p>Monitoring effectiveness would be relatively easy, based on visual inspection and groundwater monitoring.</p> <p>Monitoring and evaluating effectiveness of sediments removal will have to consider potential adverse impacts from secondary migration and physical disruption of biota during excavation activities.</p> <p>Materials to construct cap readily available. Dewatering and dredging equipment may require some lead time to secure but should be available.</p>	<p>Synthetic liner is difficult to install. Otherwise, this remedy uses conventional equipment and technologies.</p> <p>Since two barriers are installed, a composite-barrier cap would be more reliable than a single-barrier cap.</p> <p>Monitoring effectiveness would be based on visual inspection and groundwater monitoring.</p> <p>Monitoring and evaluating effectiveness of sediments removal will have to consider potential adverse impacts from secondary migration and physical disruption of biota during excavation activities.</p> <p>Materials to construct cap are readily available. Dewatering and dredging equipment may require some lead time to secure but should be available.</p>	<p>Incineration is highly questionable due to the heterogeneous nature of the waste material and its mixture with large quantities of soil and debris. Reliable confirmation sampling after excavation of sediments may be difficult.</p> <p>Monitoring effectiveness would be based on visual inspection and groundwater monitoring.</p> <p>Same as Alternative 2 and 3 for monitoring and evaluating effectiveness of sediments removal.</p> <p>Materials to construct cap are readily available. Dewatering and dredging equipment may require some lead time to secure but should be available. Likewise, incineration equipment should be available but will require some lead time, including time for pilot testing.</p>

**Table 6-1
RECOMMENDED ALTERNATIVES: SUMMARY OF DETAILED ANALYSIS
EXAMPLE SITE**

	Alternative 1	Alternative 2	Alternative 3	Alternative 4
	No Action	Single-Barrier Cap Consolidation of Hot Spot High-Strength Groundwater (Leachate) Collection and Onsite Treatment Low-Strength Groundwater Extraction and Onsite Treatment Discharge to Unnamed Tributary Consolidation of Surface Water Sediments Institutional Controls Five-Year Review	Composite-Barrier Cap Consolidation of Hot Spot High-Strength Groundwater (Leachate) Collection and Onsite Treatment Low-Strength Groundwater Extraction and Onsite Treatment Discharge to Unnamed Tributary Consolidation of Surface Water Sediments Institutional Controls Five-Year Review	Single-Barrier Cap Treatment of Hot Spot (onsite) High-Strength Groundwater (Leachate) Collection and Onsite Treatment Low-Strength Groundwater Extraction and Onsite Treatment Discharge to Unnamed Tributary Consolidated of Surface Water Sediments Institutional Controls Five-Year Review
Evaluation Criteria				
Implementability (continued) ! Administered Feasibility - Ability to coordinate and obtain approval from other agencies	Administrative problems affecting alternative feasibility are not expected. However, no action will likely be unacceptable since the remedy is not protective and there will not be compliance with ARARs.	Discussions with the state for an NPDES permit for discharge of treated groundwater to the unnamed tributary to the Polk River are uncertain and may extend into design.	Discussions with the state for an NPDES permit for discharge of treated groundwater to the unnamed tributary to the Polk River are uncertain and may extend into design.	Sufficient space must be available onsite to build incinerator. More difficult to implement than other alternatives. Same as Alternative 2 and 3 for discharge of treated groundwater.
COST	None.	Medium.	Medium-high.	High.

6.1 Example Site ARARs

In addition to the potential federal ARARs listed in Section 5, state requirements for the example site that are promulgated, more stringent than federal requirements, and applicable or relevant and appropriate are discussed below. It is emphasized that this discussion on specific state ARARs applies only to the Example Site. The purpose of this discussion is to present some typical state requirements that may affect the development and evaluation of remedial alternatives.

6.1.1 Chemical-Specific ARARs

6.1.1.1 Groundwater

Chemical-specific state standards for the Example Site include state groundwater enforcement clean-up standards and preventive action limits. A list of the specific state groundwater enforcement standards and preventative action limits that apply to the example site can be found in Appendix A. Typically, corrective actions may be more extensive if enforcement standards are exceeded. In general, preventive action limits apply wherever groundwater is monitored. State enforcement standards apply at the following locations:

- Any point of groundwater use
- At or beyond the property boundary of the facility
- Any point within the property boundary beyond the three-dimensional design management zone, if one is established by the state

The design management zone is an imaginary boundary at some horizontal distance from the waste boundary that extends downward through all saturated geologic formations. For land disposal facilities with feasibility studies that were approved by the state after October 1, 1985, a horizontal distance of 150 feet is used for the design management zone.

6.1.1.2 Surface Water

Potential state ARARs for the Example Site for protection of aquatic life include state ambient water quality criteria for aquatic life protection. A list of the specific state ambient water quality criteria that apply to the Example Site can be found in Appendix A. Any direct discharge of treated water (including groundwater or leachate) to the unnamed tributary of the Polk River would likely have to achieve these standards to comply with NPDES requirements.

6.1.2 Location-Specific ARARs

No location-specific state ARARs exist that are stricter than the federal ARARs listed in Table 5-2. Most significantly, the site is not located within the 100-year floodplain nor have wetlands been impacted by the Example Site.

6.1.3 Action-Specific ARARs

6.1.3.1 Soils/Landfill Contents

The Example Site has more stringent action-specific state ARARs than the federal ARARs for the construction of a solid waste landfill cover. Portions of these cover requirements specify including a 2-foot clay layer with a 1.5- to 2.5-foot cover layer and 0.5 foot of topsoil on the surface. The purpose of this requirement is to assure that adequate freeze-thaw protection is included in the design of the cap. Otherwise, expansion and contraction during freeze-thaw events could result in the formation of cracks in the landfill cover.

6.2 Development of Alternatives

When developing alternatives, it is important to reevaluate pathways from the conceptual site model that may not represent a significant threat to human health or the environment at this site. For example, landfill gas does not appear to be a significant threat to human health and the environment at the Example Site because the area is rural and only a small

amount of gas is generated. Therefore, future use of the site may allow some access (such as for hunting). Because some landfill gas is likely to be generated, it may be appropriate to include passive vents in the design of a landfill cap.

For municipal landfill sites with minimal hazardous waste and no known hot spots, it may not be necessary to consider a composite-barrier cap or soils treatment and consolidation. An exception might be sites where erosion has dispersed some contaminated soils without any discernable hot spots. In these instances, some consolidation of surficial soils may reduce the area that needs to be capped.

The range of alternatives developed for the Example Site is composed of the four alternatives described below.

6.2.1 Alternative 1--No Action Alternative

Under Alternative 1, no action would be taken. The no-action alternative is required as part of the NCP and provides a baseline against which other alternatives can be compared.

6.2.2 Alternative 2

Alternative 2 is composed of the four components listed below.

Component 1. Containment

- Construction of a single-barrier cap (to cover entire landfill). Freeze-thaw protection would be included as part of the design of the cap. Passive vents would be installed to vent landfill gas. Long-term monitoring of landfill gas would also be included as part of the remedy.
- Surface controls (as part of cap construction)
 - S Grading
 - S Revegetation

Component 2. Consolidation of the hot spot under the clay cap

- Since the hot spot is generally within the landfill contents, consolidation would only be required to the extent necessary to minimize the size of the landfill cap.

Component 3. Groundwater extraction and treatment

- High-strength groundwater (leachate) collection by perimeter wells, and onsite treatment with discharge to the unnamed tributary to the Polk River
- Low-strength groundwater (offsite) extraction (by wells) and onsite treatment with discharge to the unnamed tributary to the Polk River

Component 4. Consolidation of surface water sediments under landfill cap

- Consolidation of surface water sediments from the unnamed tributary would include dredging the sediments and consolidating them with other material under the landfill cap.

Component 5. Institutional controls

- Deed restrictions to:
 - S Limit site access
 - S Prohibit groundwater use

Component 6. Five-year review

Alternative 2 would minimize infiltration of surface water and potential for direct contact with the landfill contents. Passive vents would be installed to prevent accumulation of landfill gas. Perimeter wells would be installed around the landfill to capture high-strength groundwater (leachate) resulting from onsite contamination. Downgradient extraction wells would be

installed to capture offsite groundwater. The selection of a groundwater extraction rate for collection and treatment of offsite groundwater would be determined during design. It is estimated that, if a total offsite groundwater extraction rate of 500 gpm is selected, it would require at least 5 years to achieve MCLs at the landfill boundary. If a total offsite groundwater extraction rate of 200 gpm is selected, it is estimated that at least 15 years would be required to achieve MCLs at the landfill boundary. These estimates assume that the onsite perimeter groundwater extraction wells would be completely effective at controlling offsite migration of leachate. Extracted groundwater would be treated onsite and discharged to the unnamed tributary to the Polk River.

High-strength (onsite) groundwater would require removal of inorganics using metals precipitation, removal of oxygen demand (BOD, COD) using activated sludge biological treatment, and removal of VOCs and semivolatiles using air stripping or GAC. Low-strength (offsite) groundwater would only require removal of VOCs and semivolatiles. Because the site is rural and because the threat due to direct contact would be minimized, construction of a fence has not been included in this alternative. Deed restrictions, however, would be placed, prohibiting onsite groundwater use or site development.

Sediment consolidation (from the unnamed tributary) could reduce the potential for offsite migration of contamination in the long term. However, sediment dredging could have unacceptable short-term impacts due to resuspension of contaminated sediments. To minimize short-term impacts, temporary dewatering of the excavation areas should be performed before sediment removal.

6.2.3 Alternative 3

Alternative 3 is composed of the six components listed below.

Component 1. Containment

- Composite-barrier cap
 - S The layers of the composite-barrier cap may include (from the top): a vegetative layer, a drainage layer, a flexible membrane liner (first barrier), a clay layer (second barrier), and a bedding layer. As with a clay cap, freeze/thaw protection (that is, 3 feet of soil) would be part of the design of the composite-barrier cap. The design would also include the installation of passive vents to vent landfill gas. Long-term monitoring of landfill gas would also be included as part of the remedy.
- Surface controls (as part of cap construction)
 - S Grading
 - S Revegetation

Component 2. Consolidation of the hot spot under the landfill cap

- Since the hot spot is generally within the landfill contents, consolidation would be required only to the extent necessary to minimize the size of the landfill cap.

Component 3. Groundwater extraction and treatment

- Collection via perimeter wells and onsite treatment of high-strength groundwater (leachate). Effluent would be discharged to the unnamed tributary to the Polk River.
- Offsite extraction (by wells) and onsite treatment of low-strength groundwater. Effluent would be discharged to the unnamed tributary to the Polk River.

Component 4. Consolidation of surface water sediments under landfill cap

- Consolidation of surface water sediments from the unnamed tributary would include dredging the sediments and consolidating them with other material under the landfill cap.

Component 5. Institutional controls

- Deed restrictions to:
 - S Limit site access
 - S Prohibit groundwater use

Component 6. Five-year review

Alternative 3 is similar to Alternative 2 except a composite-barrier cap would be constructed instead of a single-barrier cap. A composite-barrier cap would provide maximum protection against direct contact and would minimize potential infiltration. A composite-barrier cap would also adhere to the design requirements of RCRA guidance for new landfill cells. As with Alternative 2, the selection of a pumping rate for extraction of offsite groundwater would be determined during design.

6.2.4 Alternative 4

Alternative 4 is composed of the six components listed below.

Component 1. Containment

- Single-barrier cap
 - S Includes installation of passive vents for landfill gas and long-term monitoring of landfill gas
- Surface controls (as part of cap construction)
 - S Grading
 - S Revegetation

Component 2. Treatment of the hot spot

- Onsite incineration
- Consolidation of ash under landfill cap

Component 3. Groundwater extraction and treatment

- Collection and onsite treatment of high-strength groundwater (leachate). Effluent would be discharged to the unnamed tributary to the Polk River.

S Perimeter wells

- Low-strength groundwater extraction and onsite treatment. Effluent would be discharged to the unnamed tributary to the Polk River.

S Offsite wells

Component 4. Consolidation of surface water sediments under landfill cap

- Consolidation of surface water sediments from the unnamed tributary would include dredging the sediments and consolidating them with the other material under the landfill cap.

Component 5. Institutional controls

- Deed restrictions to:
 - S Limit site access
 - S Prohibit groundwater use

Component 6. Five-year review

In addition to the components outlined for Alternative 2, Alternative 4 includes treatment of material excavated from the hot spot area by onsite incineration. Consolidation of the ash under the landfill cap is anticipated. By including treatment, this alternative would provide some reduction in toxicity, mobility, or volume. Because the hot spot area would be treated rather than consolidated under the cap, a single-barrier cap is considered adequate.

6.3 Comparative Analysis of Alternatives

As part of the feasibility study, an individual analysis is conducted where each of the remediation alternatives is compared to the nine criteria described in Section 5 of this document (see Table 6-1). A comparative analysis of alternatives is conducted following the individual analysis. The comparative analysis focuses on the significant differences between the alternatives. Because all the alternatives (except no action) include collection and treatment of leachate and offsite contaminated groundwater, the comparative analysis does not focus on this aspect of the remedial action. A pump and treat alternative is more effective, protective, expensive, and reliable than no action, and reduces the volume of contaminants. It is also more difficult to implement.

A comparative analysis of the alternatives with respect to the threshold criteria and balancing criteria follows. As with the individual analysis, the modifying criteria of state acceptance and community acceptance are not included because they are used to modify an alternative based on formal state and community comments once the proposed plan has been released.

6.3.1 Overall Protection of Human Health and the Environment

Alternatives 2 through 4 are protective of human health and the environment. Ingestion of contaminated groundwater is prevented by groundwater collection and treatment. Direct contact with waste and release of VOCs from waste would be mitigated by either of the proposed caps. The combination of the leachate collection system (perimeter wells), offsite groundwater extraction wells, and either a single- or composite-barrier cap would mitigate groundwater contamination.

The decrease in permeability of the composite-barrier cap does not increase its protectiveness, just its effectiveness and reliability. The potential increase in infiltration from using a single-barrier cap instead of a composite-barrier cap may increase the amount of leachate that is collected and treated but will not necessarily reduce protectiveness. Incineration of the hot spot may

increase protectiveness by reducing the contaminant source and subsequent contaminant load to groundwater, thereby potentially reducing groundwater and leachate treatment costs.

The no-action alternative is not considered protective since risk from the various pathways is not controlled.

6.3.2 Compliance With ARARS

The state in which the Example Site is located requires sanitary landfills to be closed with a cap consisting of 2 feet of clay as a minimum barrier layer and sufficient cover material to protect against freeze/thaw damage. Alternatives 2, 3, and 4 will be designed to meet this requirement. The incinerator and groundwater pump and treat system would also be designed to meet all action- and chemical-specific ARARS.

The objective of Alternatives 2 through 4 would be to meet chemical-specific ARARs for groundwater (for example, MCLs, MCLGs, state groundwater enforcement standards) at the landfill boundary. For these standards to be maintained (once they are achieved), the leachate collection system (perimeter wells) and the landfill cap would have to be maintained.

The no-action alternative would not be in compliance with ARARS.

6.3.3 Short-Term Effectiveness

Effects on the community during remedial actions are related to the degree of truck traffic needed to import cap materials and the amount of earth moved during cap construction. The truck traffic of Alternative 3 (composite-barrier cap) is anticipated to be slightly greater than Alternatives 2 and 4, and significantly greater than the no-action alternative. The truck traffic would cause nuisances from noise and dust and increase the risk of vehicular accidents.

Adverse health effects on the community may be increased by Alternative 4 (treatment of hot spot) as a result of waste disturbance and the possibility of improper air emissions from incinerator malfunctions or poor destruction efficiency. Although air emission controls and

monitoring can limit risk from incinerator air emissions, it would be more difficult to control VOC releases as a result of disturbing the waste. The rural nature of the site should make the effects negligible.

Adverse health effects on workers during cap construction and groundwater remediation construction are not expected to be significant. Incineration of soils in the hot spot (Alternative 4) may pose a greater risk to workers than consolidation of the hot spot under the landfill cap (Alternatives 2 and 3). Alternatives 2, 3, and 4 all involve excavation of the hot spot, which may pose risks to workers from potential VOC emissions. However, since the hot spot is generally within the landfill, consolidation (Alternatives 2 and 3) may involve only a small amount of excavation to minimize the size of the landfill cap, whereas excavation and incineration (Alternative 4) would involve excavation of the entire hot spot area and may result in a greater risk from VOC emissions. Alternative 4 may also result in greater risk of construction injuries from assembly of the materials handling and incinerator system, and excavation and consolidation of surface water sediments. Compared to the no-action alternative, all three alternatives have a significant increase in risk to workers.

Environmental impacts for Alternatives 2, 3, and 4 do not differ significantly. There is a possibility of waste or runoff affecting the Polk River during implementation of these alternatives.

The time required for implementation of source controls is the only time variation between Alternatives 2, 3, and 4. Design and construction would require from 2 years for Alternatives 2 and 3 (consolidate hot spot and cap) to 4 years for Alternative 4 (incinerate hot spot and cap).

6.3.4 Long-Term Effectiveness

All alternatives leave the landfill in place and rely on institutional controls, such as state prohibition of construction on landfills, to prevent development. If the landfill is developed, hazardous materials could be deposited on the surface from earth-moving activities (grading or excavation), resulting in

exposure to users of the site or transport of contaminants to the unnamed tributary of the Polk River. Assuming regular cap maintenance, Alternatives 2, 3, and 4 are roughly equivalent in their ability to prevent direct contact and erosion.

The amount of residuals is typically gauged by the contaminant mass that would reach the groundwater. While this is difficult to estimate, the effect of the residuals is related to the infiltration rate and the remaining contaminant mass. Alternative 4 removes and treats the hot spot, thereby removing a significant portion of the contaminant mass. Alternative 3 uses a composite-barrier cap, which would reduce infiltration more effectively than the single-barrier clay cap proposed for Alternatives 2 and 4. It is estimated that infiltration could be reduced by as much as 75 percent by using a composite-barrier cap instead of a single-barrier clay cap. Alternatives 2, 3, and 4 all offer a significant effectiveness advantage over the no-action alternative.

The composite-barrier cap is more reliable than a clay cap because of the extra barrier. Maintaining the long-term reliability and effectiveness of both types of caps would require continued operations and maintenance. Incineration of the hot spot by Alternative 4 may reduce the critical need of maintaining cap reliability by reducing the source of contamination.

6.3.5 Reduction of Toxicity, Mobility, and Volume Through Treatment

All of the alternatives, except the no-action alternative, have groundwater treatment. The reduction in toxicity, mobility, or volume from groundwater treatment would be the same for Alternatives 2, 3, and 4. The only significant difference concerning treatment is the use of incineration in Alternative 4. Compared to the landfilled material, the amount of hazardous material treated is not estimated to be large. Yet, because the treated area represents the most contaminated material, the toxicity of the remaining material would be significantly reduced. Incineration is a permanent, nonreversible treatment process.

6.3.6 Implementability

While Alternatives 2, 3, and 4 have no serious implementability issues, there are differences between the alternatives. The synthetic liner for Alternative 3 requires special handling during installation to ensure integrity. The incinerator for Alternative 4 may take some effort to locate. Trial burns will then be necessary. Considerable operating attention will be required because of the heterogeneous nature of the waste. In addition, the technical intent of relevant emission permits will have to be met and demonstrated before the incinerator can operate.

6.3.7 Costs

The costs of the alternatives increase incrementally from no-action to Alternative 4. The relative costs of the alternatives are shown in Table 6-1.

6.4 Section 6 Summary

This section has been developed to illustrate how the evaluation process is applied to a typical CERCLA municipal landfill site. The previous sections focused primarily on technologies that are most practicable for landfill sites. This section demonstrates how these technologies might be combined into alternatives and evaluated.

Section 7 BIBLIOGRAPHY

Adamus, P.E. et al. *Wetland Evaluation Technique (WET): Volume II--Methodology*. U.S. Army Corps of Engineers. 1987.

American Public Health Association et al. *Standard Methods for the Examination of Water and Wastewater*. 16th ed. 1985.

American Society for Testing and Materials. ASTM Standard D420, *Standard Guide for Investigating and Sampling Soil and Rock*.

American Society for Testing and Materials. ASTM Standard D 1587, *Standard Practice for Thin-Walled Tube Sampling of Soils*.

American Society for Testing and Materials. ASTM Standard D4220, *Standard Practices for Preserving and Transporting Soil Samples*.

American Society for Testing and Materials. ASTM Standard D5084, *Hydraulic Conductivity of Saturated Porous Materials Using a Flexible Wall Permeameter*.

Argonne National Laboratory. *An Annotated Bibliography: Environmental Impacts of Sanitary Landfills and Associated Gas Recovery Systems*. ANL/CNSV-27. February 1982.

Battelle, Pacific Northwest Laboratories. *Comparison of Two Groundwater Flow Models: UWSATID and HELP*. Richland, Washington. 1984.

Battelle, Pacific Northwest Laboratories. *Physiochemical Measurements of Soils at Solid-Waste Disposal Sites*. Electric Power Research Institute. Final Report. EPRI EA-4417, Project 2485-3. January 1986.

Bear, J. *Hydraulics of Groundwater*. New York: McGraw-Hill. 1979.

Bevan, B.W. *Quantitative Magnetic Analysis of Landfills*. Geosight. 1983.

Bouwer, H., and R.C. Rice. *A Slug Test for Determining Hydraulic Conductivity of Unconfined Aquifers with Completely or Partially Penetrating Wells*. Phoenix, Arizona: Agricultural Research Service, U.S. Department of Agriculture. 1976.

Cedergren, H. *Seepage, Drainage, and Flow Net*. New York: John Wiley and Son. 1989.

Chamberlain, E.J., and A.J. Gow. Effect of Freezing and Thawing on the Permeability and Structure of Soils. *Engineering Geology* 13 (1979): pp. 73-92.

Cheremisinoff, P.N., and F. Ellerbush. *Carbon Adsorption Handbook*. Ann Arbor, Michigan: Ann Arbor Science. 1980.

Clark, Viessman, and Hammer. *Water Supply and Pollution Control*. New York: IEP-Dun-Donnell. 1977.

Cooper, H.H., Jr., J.D. Bredehoeft, and I.S. Papadopoulos. Response of a Finite Diameter Well to an Instantaneous Charge of Water. *Water Res. Res.* 3 (1967): pp. 263-69.

Daniel, D.E. "In Situ Hydraulic Conductivity Tests for Compacted Clay." *Journal of Geotechnical Engineering*, 115:9 (1989), pp. 1205-1226.

Emcon Associates-Ann Arbor Science. *Methane Generation and Recovery from Landfills*. Ann Arbor, Michigan: Ann Arbor Science. 1980.

England, C.B. *Land Capability: A Hydrologic Response Unit in Agricultural Watersheds*. Agricultural Research Service. U.S. Department of Agriculture. 1970. pp. 41-172

Fowler, J.W., and D.L. Pasicznyk. *Magnetic Survey Methods Used in the Initial Assessment of a Waste Disposal Site*. New Jersey Department of Environmental Protection.

Freeze, R.A., and J.A. Cherry. *Groundwater*. New York: Prentice-Hall. 1979.

Ghassemi, M. *Assessment of Technology for Constructing and Installing Cover and Bottom Liner Systems for Hazardous Waste Facilities: Volume I*. Ghassemi EPA Contract No. 68-02-3174. U.S. Environmental Protection Agency. May 1983.

Hammer, D.A. *Constructed Wetlands for Wastewater Treatment*. Chelsea, Michigan: Lewis Publishers. 1989.

Hantush, M.S. and C.E. Jacob. Non-Steady Radial Flow in an Infinite Leaky Aquifer. *Trans. Am. Geophys. Union* 36 (1955): pp. 96-100.

Hvorslev, M.J. *Subsurface Exploration and Sampling of Soils for Civil Engineering Purposes*. Cambridge: Engineering Foundation, Harvard University Waterways Experiment Station. November 1949.

International Institute for Land Reclamation and Improvement. *Drainage Principles and Applications*. Wageningen, The Netherlands. 1979.

Javandel, I., and C.F. Tsang. Capture-Zone Type Curves: A Tool for Aquifer Cleanup. *Groundwater* 24 (September-October 1986): p. 5.

Keely. Optimizing Pumping Strategies for Containment Studies and Remedial Actions. *Groundwater Monitoring Review*. Summer 1984. pp. 63-74.

Keely and Tsang. Velocity Plots and Capture Zones of Pumping Centers for Ground-water Investigations. *Groundwater*. 21 (1983): pp. 701-14.

Kmet, P., K.J. Quinn, and C. Slavik. *Analysis of Design Parameters Affecting the Collection Efficiency of Clay Lined Landfills*. University of Wisconsin. September 1981.

Lutton, R.J. *Evaluating Cover Systems for Solid and Hazardous Waste*. SW867. U.S. Environmental Protection Agency. 1982.

Lyman, W.J. *Handbook of Chemical Property Estimation Methods*. New York: McGraw-Hill. 1982.

Metcalf & Eddy, Inc., revised by Tchobanoglous. *Wastewater Engineering. Treatment, Disposal, Reuse*. 2nd ed. New York: McGraw-Hill. 1979.

Michaels, P.A., and M.K. Stinson. *Technology Evaluation Report, Vacuum Extraction System*. Groveland, Massachusetts: Risk Reduction Engineering Laboratory. Ordinance EA68-03-3255. 1989.

Milne-Thomson, L.M. *Theoretical Hydrodynamics*. New York: Macmillan Company. 1968.

Montgomery, R.J. et al. Use of Downhole Geophysical Methods in Determining the Internal Structure of a Large Landfill. *The Surface and Borehole Proceedings*. Fort Worth, Texas. 1985.

Morel-Seytoux, H.J., and C.J. Daly. A Discrete Kernel Generator for Stream Aquifer Studies. *Water Res. Res.* 11 (1975): pp. 253-60.

Morrison, W.R., and L.R. Simmons. *Chemical and Vegetative Stabilization of Soil: Laboratory and Field Investigations of New Materials and Methods for Soil Stabilization and Erosion Control*. U.S. Bureau of Reclamation Report No. 7613. 1977.

National Institute of Occupational Safety and Health. *Occupational Safety and Health Guidance Manual for Superfund Activities*. 1984.

Neuman, S.P. Theory of Flow in Unconfined Aquifers Considering Delayed Responses of the Water Table.

Noyes Data Corporation. Landfill Methane Recovery. *Energy Technology Review* 80. 1983.

Papadopoulos, I.S., J.D. Bredehoeft, and H.H. Cooper, Jr. On the Analysis of Slug Test Data. *Water Res. Res.* 9 (1973): pp. 1087-89.

Residuals Management Technology, Inc. *Field Measurement Methods for Hydrogeologic Investigations: A Critical Review of the Literature*. Electric Power Research Institute. EPRI EA-4301, Project 2485-7. October 1985.

Sai, J.O., and D.C. Anderson. "Field Hydraulic Conductivity Tests for Compacted Soil Liners." *Geotechnical Testing Journal*, 13:3 (1990), pp. 215-225.

Seebold, James A. Practical Flare Design. *Chemical Engineering*. December 1984.

Theis, C.V. The Relation between the Lowering of the Piezometric Surface and the Rate and Duration of a Well using Groundwater Storage. *Trans. Am. Geophys. Union* 16 (1935): pp. 519-24.

Thiem, G. *Hydrologische Methoden*. Leipzig: Gebhardt. 1906.

Treybal, R. *Mass Transfer Operations*. 3rd ed. New York: McGraw-Hill. 1983.

U.S. Army Corps of Engineers. *Dewatering and Groundwater Control for Deep Excavations*. U.S. Army Engineers Waterways Experiment Station. Technical Manual No. 5-818-5. 1971.

U.S. Army Corps of Engineers. *Wetland Evaluation Technique (WET)*. U.S. Army Engineers Waterways Experiment Station. 1987.

U.S. Environmental Protection Agency. *Design and Construction of Covers for Solid Waste Landfills*. EPA/600/2-79/165. August 1979a.

U.S. Environmental Protection Agency. *Water Related Environmental Fate of 129 Priority Pollutants*. EPA/440/4-79/029A. December 1979b.

U.S. Environmental Protection Agency. *RCRA Guidance Document Landfill Design, Liner Systems and Final Cover (Draft)*. July 1982a.

U.S. Environmental Protection Agency. *Fate of Priority Pollutant in Publicly Owned Treatment Works*. EPA/440/1-82/303. 1982b.

U.S. Environmental Protection Agency. *Handbook for Sampling and Sampling Preservation of Water and Wastewater*. EPA/600/4-82/029. 1982c.

U.S. Environmental Protection Agency. *Methods for Analysis of Water and Waste*. EPA/600/4-79/020. March 1983a.

U.S. Environmental Protection Agency. *Lining of Waste Impoundment and Disposal Facilities*. SW870. 1983b.

U.S. Environmental Protection Agency. *Permit Guidance Manual on Hazardous Waste Land Treatment Demonstrations* (Draft). EPA/530/SW-84/015. December 1984a.

U.S. Environmental Protection Agency. *Procedures for Modeling Flow through Clay Liners to Determine Required Liner Thickness*. EPA/530/SW-84/001. 1984b.

U.S. Environmental Protection Agency. *Standard Operating Safety Guides*. 1984c.

U.S. Environmental Protection Agency. *Handbook of Remedial Action at Waste Disposal Sites (Revised)*. EPA/625/6-85/006. October 1985a.

U.S. Environmental Protection Agency. *Leachate Plume Management*. EPA/540/2-85/004. November 1985b.

U.S. Environmental Protection Agency. *Guide for Identifying Cleanup Alternatives at Hazardous Waste Sites and Spills*. EPA/600/3-83/063. December 1985c.

U.S. Environmental Protection Agency. *Covers for Uncontrolled Hazardous Waste Sites*. EPA/540/2-85/002. 1985d.

U.S. Environmental Protection Agency. *Guidance on Remedial Investigations under CERCLA*. 1985e.

U.S. Environmental Protection Agency. *Standard Operating Procedures and Quality Assurance Manual*. Region IV Water Surveillance Branch. April 1986a.

U.S. Environmental Protection Agency. *Quality Criteria for Water*. EPA/44/5-86/001. May 1986b.

U.S. Environmental Protection Agency. *Groundwater Monitoring Technical Enforcement Guidance Document*. OSWER-9950.1. September 1986c.

U.S. Environmental Protection Agency. *RCRA Groundwater Monitoring Technical Enforcement Guidance*. OSWER-9950.1. September 1986d.

U.S. Environmental Protection Agency. *Systems to Accelerate In Situ Stabilization of Waste Deposits*. EPA/540/2-86/002. September 1986e.

U.S. Environmental Protection Agency. *Test Methods for Evaluating Solid Waste, Physical/Chemical Methods*. 3rd ed. November 1986f.

U.S. Environmental Protection Agency. *Technology Briefs, Data Requirements for Selecting Remedial Action Technology*. EPA/600/2-87/001. January 1987a.

U.S. Environmental Protection Agency. *Data Quality Objectives for Remedial Response Activities: Example Scenario: RI/FS Activities at a Site with Contaminated Soils and Groundwater*. EPA/540/G-87/004 (OSWER Directive 9355.0-7B). March 1987b.

U.S. Environmental Protection Agency. *Data Quality Objectives for Remedial Response Activities. Volume I. Development Process*. EPA/540/G-87/003. March 1987c.

U.S. Environmental Protection Agency. *Data Quality Objectives for Remedial Response Activities. Volume II. RI/FS Activities at a Site with Contaminated Soils and Groundwater*. EPA/540/G-87/004. March 1987d.

U.S. Environmental Protection Agency. *A Compendium of Technologies Used in the Treatment of Hazardous Wastes*. EPA/625/8-87/014. September 1987e.

U.S. Environmental Protection Agency. *Characterization of MWC Ashes and Leachates from MSD Landfills, Monofills, and Co-Disposal Sites*. EPA/530/SW-87/028A. October 1987f.

U.S. Environmental Protection Agency. *Revised Procedures for Implementing Off-Site Response Actions*. OSWER 9834.11. November 1987ff.

U.S. Environmental Protection Agency. *Contract Laboratory Program Statement of Work (SOW) for Inorganic Analysis. Multimedia, Multiconcentration*. December 1987g.

U.S. Environmental Protection Agency. *A Compendium of Superfund Field Operations Methods*. EPA/540/P-87/001. 1987h.

U.S. Environmental Protection Agency. *Contract Laboratory Program Statement of Work (SOW) for Organics Analysis: Multimedia, Multiconcentration*. February 1988a.

U.S. Environmental Protection Agency. *Superfund Exposure Assessment Manual*. EPA/540/1-88/001. April 1988b.

U.S. Environmental Protection Agency. *CERCLA Compliance with Other Laws Manual*. EPA/540/G-89/006. August 1988c.

U.S. Environmental Protection Agency. *Technology Screening Guide for Treatment of CERCLA Soils and Sludges*. EPA/540/2-88/004. September 1988d.

U.S. Environmental Protection Agency. *Guidance for Conducting Remedial Investigations and Feasibility Studies under CERCLA*. Interim Final. EPA/540/G-89/004. October 1988e.

U.S. Environmental Protection Agency. *Guidance on Remedial Actions for Contaminated Groundwater at Superfund Sites*. EPA/540/6-88/003. December 1988f.

U.S. Environmental Protection Agency. *Constructed Wetlands and Aquatic Plant Systems for Municipal Wastewater Treatment*. EPA/625/1-88/022. 1988g.

U.S. Environmental Protection Agency. *Experience in Incineration Applicable to Superfund Site Remediation*. EPA/625/9-88/008. 1988g.

U.S. Environmental Protection Agency. *Statistical Methods for Evaluating the Attainment of Superfund Cleanup Standards. Volume I. Soils and Solid Media*. NTIS PB-89-234-959. February 1989a.

U.S. Environmental Protection Agency. *Ecological Assessment of Hazardous Waste Sites: A Field and Laboratory Reference*. EPA/600/3-89/013. March 1989b.

U.S. Environmental Protection Agency. *Risk Assessment Guidance for Superfund. Volume II. Environmental Evaluation Manual*. Interim Final. EPA/540/1-89/001. March 1989c.

U.S. Environmental Protection Agency. *Final Covers on Hazardous Waste Landfills and Surface Impoundments*. EPA/530/SW-89/047. July 1989d.

U.S. Environmental Protection Agency. *Exposure Factors Handbook*. EPA/600/8-89/043. July 1989e.

U.S. Environmental Protection Agency. *Technical Guidance Document: Final Covers on Hazardous Waste Landfills and Surface Impoundments*. EPA/530/SW-89/047. July 1989f.

U.S. Environmental Protection Agency. *Evaluation of Groundwater Extraction Remedies, Volume I, Summary Report*. EPA/540/2-89/054. September 1989g.

U.S. Environmental Protection Agency. *Determining Soil Response Action Levels Based on Potential Contaminant Migration to Groundwater: A Compendium of Examples*. EPA/540/2-89/057. October 1989h.

U.S. Environmental Protection Agency. *The Superfund Innovative Technology Evaluation Program: Technology Profiles*. EPA/540/5-89/013. November 1989i.

U.S. Environmental Protection Agency. *Guide for Conducting Treatability Studies under CERCLA*. EPA/540/2-89/058. December 1989j.

U.S. Environmental Protection Agency. *Risk Assessment Guidance for Superfund. Volume I. Human Health Evaluation Manual (Part A)*. Interim Final. EPA/540/1-89/002. December 1989k.

U.S. Environmental Protection Agency. *Summary of Treatment Technology Effectiveness for Contaminated Soil*. EPA/540/2-89/053. December 1989m.

U.S. Environmental Protection Agency. *Performance Evaluations of Pump and Treat Remediations: Groundwater Issue Paper*. EPA/540/4-89/005. 1989n.

U.S. Environmental Protection Agency. *Handbook on In Situ Treatment of Hazardous Waste-Contaminated Soils*. EPA/540/2-90/002. January 1990a.

U.S. Environmental Protection Agency. *Basics of Pump-and-Treat Groundwater Remediation Technology*. EPA/600/8-90/003. March 1990b.

U.S. Environmental Protection Agency. *Basics of Pump-and-Treat Remediation Technology*. EPA/600/8-90/003. March 1990c.

U.S. Environmental Protection Agency. *Criteria for the Evaluation of RCRA Groundwater Detection Monitoring Systems (Draft)*. June 1990d.

U.S. Environmental Protection Agency. *Terra Vac In Situ Vacuum Extraction System, Applications Analysis Report*. EPA/540/A5-89/003. July 1990e.

U.S. Environmental Protection Agency. *CERCLA Site Discharges to POTWs*. EPA/540/6-90/005. August 1990f.

U.S. Environmental Protection Agency. *International Waste Technologies/Geo Con In Situ Stabilization/Solidification, Applications Analysis Report*. EPA/540/A5-89/004. August 1990g.

U.S. Environmental Protection Agency. *High Temperature Treatment for CERCLA Waste: Evaluation of Onsite and Offsite Systems*. EPA/540/4-89/006. 1989f.

U.S. Environmental Protection Agency. *Stabilization/Solidification of CERCLA and RCRA Wastes--Physical Tests, Chemical Testing Procedures, Technology Screening and Field Activities*. EPA/625/6-89/022. 1989g.

U.S. Environmental Protection Agency. *State of Technology Review: Soil Vapor Extraction Systems*. EPA/600/2-89/024. 1989h.

U.S. Fish and Wildlife Service et al. *Federal Manual for Identifying and Delineating Jurisdictional Wetlands: An Interagency Cooperative Publication*. 1989.

U.S. Geological Survey. *Application of Drilling, Coring, and Sampling Techniques to Test Holes and Wells. Techniques of Water-Resource Investigations of the United States Geological Survey*. U.S. Department of the Interior.

U.S. Geological Survey. WATSTORE files.

U.S. Steel Corporation. *Steel Sheet Piling Handbook: Reference Data on Shapes, Materials, Performance and Applications*. Pittsburgh: United States Steel. 1976.

Viessman et al. *Introduction to Hydrology*. New York: Harper and Row. 1977.

Warner, R.C. et al. *Demonstration and Evaluation of the Hydrologic Effectiveness of a Three-Layer Landfill Surface Cover under Stable and Subsidence Conditions: Phase I Final Project Report*. U.S. Environmental Protection Agency.

Xanthakos, P. *Slurry Walls*. New York: McGraw-Hill. 1979.

Appendix A

Site Characterization Strategy
for an Example Site

CONTENTS OF APPENDIX

	Page
1. INTRODUCTION	A1-3
2. EVALUATION OF EXISTING DATA	A2-1
2.1 Site Description	A2-1
2.2 Site History	A2-1
2.3 Regional and Site-Specific Geology	A2-3
2.3.1 Regional Geology	A2-3
2.3.2 Site-Specific Geology	A2-4
2.4 Hydrology	A2-4
2.4.1 Surface Water	A2-4
2.4.2 Groundwater	A2-4
2.4.3 Surface Water-Groundwater Relationship	A2-4
2.5 Hazardous Materials Characterization	A2-6
2.5.1 Source Description	A2-6
2.5.2 Waste Description	A2-6
2.6 Cap Characterization	A2-6
2.7 Description and Results of Past Sampling and Analysis Activities	A2-7
3. SITE DYNAMICS	A3-1
3.1 Limited Field Investigation	A3-1
3.2 Conceptual Site Model	A3-1
3.3 Preliminary Exposure Assessment	A3-7
3.3.1 Chemicals Previously Detected at the Site	A3-7
3.3.2 Contaminant Source	A3-7
3.3.3 Release Mechanism	A3-7
3.3.4 Contaminant Transport	A3-7
3.3.5 Contaminant Migration	A3-8
3.3.6 Contaminant Fate	A3-8
3.3.7 Exposure Pathways	A3-8
4. PRELIMINARY IDENTIFICATION OF REMEDIAL ACTION ALTERNATIVES	A4-1
4.1 Potential ARARs for the Example Site	A4-1
4.2 Review of Analytical Results and Comparison to ARARs	A4-2
4.2.1 Baseline Risk Assessment	A4-2
4.3 Preliminary Remedial Action Objectives and Goals	A4-8

CONTENTS (cont.)

	Page
4.4 Preliminary Remedial Action Alternatives	A4-8
4.4.1 Landfill Contents	A4-9
4.4.2 Hot Spots	A4-9
4.4.3 Groundwater	A4-10
4.4.4 Landfill Gas	A4-11
4.4.5 Surface Water and Sediments	A4-11
5. REMEDIAL INVESTIGATION AND FEASIBILITY STUDY OBJECTIVES	A5-1
6. DATA QUALITY OBJECTIVES	A6-1
7. RI/FS TASKS	A7-1
7.1 RI/FS Tasks	A7-1
7.1.1 Task 1--Project Planning	A7-1
7.1.2 Task 2--Community Relations Activities	A7-2
7.1.3 Task 3--Field Investigation	A7-2
7.1.4 Task 4--Sample Analysis and Data Validation	A7-21
7.1.5 Task 5--Data Evaluation	A7-25
7.1.6 Task 6--Risk Assessment	A7-25
7.1.7 Task 7--Remedial Investigation Report	A7-25
7.1.8 Task 8--Remedial Action Alternative Report	A7-25
7.1.9 Task 9--Alternatives Evaluation	A7-26
7.1.10 Task 10--Feasibility Study Report	A7-26
7.1.11 Task 11--Treatability Studies	A7-27
8. COST AND KEY ASSUMPTIONS	A8-1
9. SCHEDULE	A9-1
10. PROJECT MANAGEMENT	A10-1
11. BIBLIOGRAPHY	A11-1

Section 1

INTRODUCTION

This appendix has been developed to illustrate how information provided in the body of this report--specifically, in Sections 2, 3, and 4 of *Conducting Remedial Investigations/Feasibility Studies for CERCLA Municipal Landfill Sites*--could be used to develop a scope of work for a specific landfill site. The example provided in this appendix should be useful to EPA, states, potentially responsible parties (PRPs), and remedial investigation contractors.

Specifically, the purpose of this appendix is:

- To present the scope of work to be completed at an example site including a site description, objectives of the RI/FS, and task-by-task breakdowns of the planned work
- To illustrate an example of the level of characterization for a CERCLA municipal landfill site necessary to support subsequent decisions (This level of characterization is based on previous experience and best engineering judgment.)
- To identify preliminary remedial action alternatives that are practicable for the example landfill site based on the NCP expectations, site conditions, and review of remedial alternatives most often used at landfill sites (see Section 4 of this report on Development and Selection of Remedial Action Alternatives.)

This RI/FS characterization strategy is developed for a specific municipal landfill site, hereafter referred to as the example site. This document will focus on hot spots, seeps, landfill gas, and groundwater/leachate as the principal media of concern. These were selected because they

are generally the media directly associated with municipallandfills. By focusing on these four media, the example scope of work can be less complicated and applied to other media. The omission of other potentially affected media, such as wetlands, in this example does not imply that they should be omitted from investigation and remediation at sites where they are present.

The example site used for preparing this work plan is described in detail in Section 2 of this appendix. In order to present technically supportable conditions for the example site, the geology and hydrology used were taken from the work plan of an actual municipal landfill site located in the State of Wisconsin. Some of the characteristics, such as the names of the river basins, rivers, and distances to hydrologic features, have been changed. In addition, an assumption has been made that the RI/FS at the example site is federally funded.

This appendix begins with a description of the example site and its history. It then presents the decisions made from evaluating existing data, conducting limited field investigations, and developing data quality objectives. Future tasks required for conducting the RI/FS are described next. These tasks follow the standardized RI/FS tasks described in Appendix B of the *RI/FS Guidance* (U.S. EPA, 1988a).

The example site is a municipal landfill that is located in a primarily rural area of County X, Wisconsin. The site was proposed for the NPL in 1982 after site inspection and HRS scoring by an EPA Field Investigation Team (FIT). Investigation by FIT indicated elevated levels of volatile organic compounds (VOCs) and metals in groundwater samples taken from nearby residential wells.

The overall goals of the RI/FS for the example site are:

- To complete a field program at the site for collecting data to determine the nature and extent of contamination at the site and the human health and environmental risks

associated with contaminants found at the site

- To develop and evaluate remedial alternatives for the site if there are unacceptable human health or environmental risks

Section 2

EVALUATION OF EXISTING DATA

This section presents a summary of the available information on the example site. Information was obtained from the HRS package, state files, interviews with past employees of the landfill, records kept by the landfill, and available engineers' reports for closure of the landfill. This section includes the following subsections:

- Site Description
- Site History
- Regional and Site-Specific Geology
- Hydrology
- Hazardous Materials Characterization
- Cap Characterization
- Description and Results of Past Sampling and Analysis Activities

2.1 Site Description

The example site, shown in Figure 2-1, is approximately 60 acres and is located in County X, Wisconsin, an area that is primarily rural. There are six residences located within one-half mile of the site and a community of 300 people is located 5 miles northwest of the landfill. The primary use of the land near the site is farming.

Approximately 20 acres of the 60-acre site are composed of a landfill which accepted both chemical wastes and municipal trash. Existing structures on the site include a gate house and an office. There is a small tributary running within 200 feet west of the site which discharges into the Polk River. Private drinking water wells, screened within a sand and gravel aquifer, are located downgradient of the site. The landfill was closed by the state in 1980 when contamination was found in these residential wells.

Industrial, commercial, and municipal wastes are generally mixed throughout the fill area, with the exception of liquid industrial solvent wastes which were generally restricted to the southeastern half of the landfill. Between 1980 and 1982, exposed areas

in the southern half of the landfill were temporarily covered with a partial cap consisting of 2 feet of compacted clay. The remainder of the landfill has a temporary soil cover although there are some areas of exposed waste. Some of the contaminants of concern are trichloroethene (TCE) and vinyl chloride (VC) in the soil and groundwater; lead, arsenic, and total chromium in the soil; and methane gas.

2.2 Site History

A summary of the landfill's history was formulated after reviewing relevant site records and correspondence for information regarding site operations, waste disposal practices, waste descriptions, site engineering studies, historical aerial photographs, and potentially responsible party operations. A condensed version of the site history follows.

The landfill, which is privately owned, was licensed by the State of Wisconsin to operate from 1969 to 1980, when the state ordered its closure. State files indicate that in 1969 the landfill began operations, receiving residential, commercial, and industrial refuse and liquid wastes. In 1971, the state required that an area be designated specifically for the disposal of liquid industrial solvents. Interviews with site operators indicated that the solvents were disposed of in the southeastern portion of the landfill to satisfy the state's requirements; however, disposal was generally done throughout the landfill prior to this time. Landfill operations during the first three years of operation were conducted without an attendant. Thereafter, operating hours were posted and an operator was present to record incoming waste and to measure the nonresidential waste for record-keeping and billing purposes.

Daily landfill operation records indicate that two major industrial companies began solvent waste disposal in 1970. The solvent wastes were

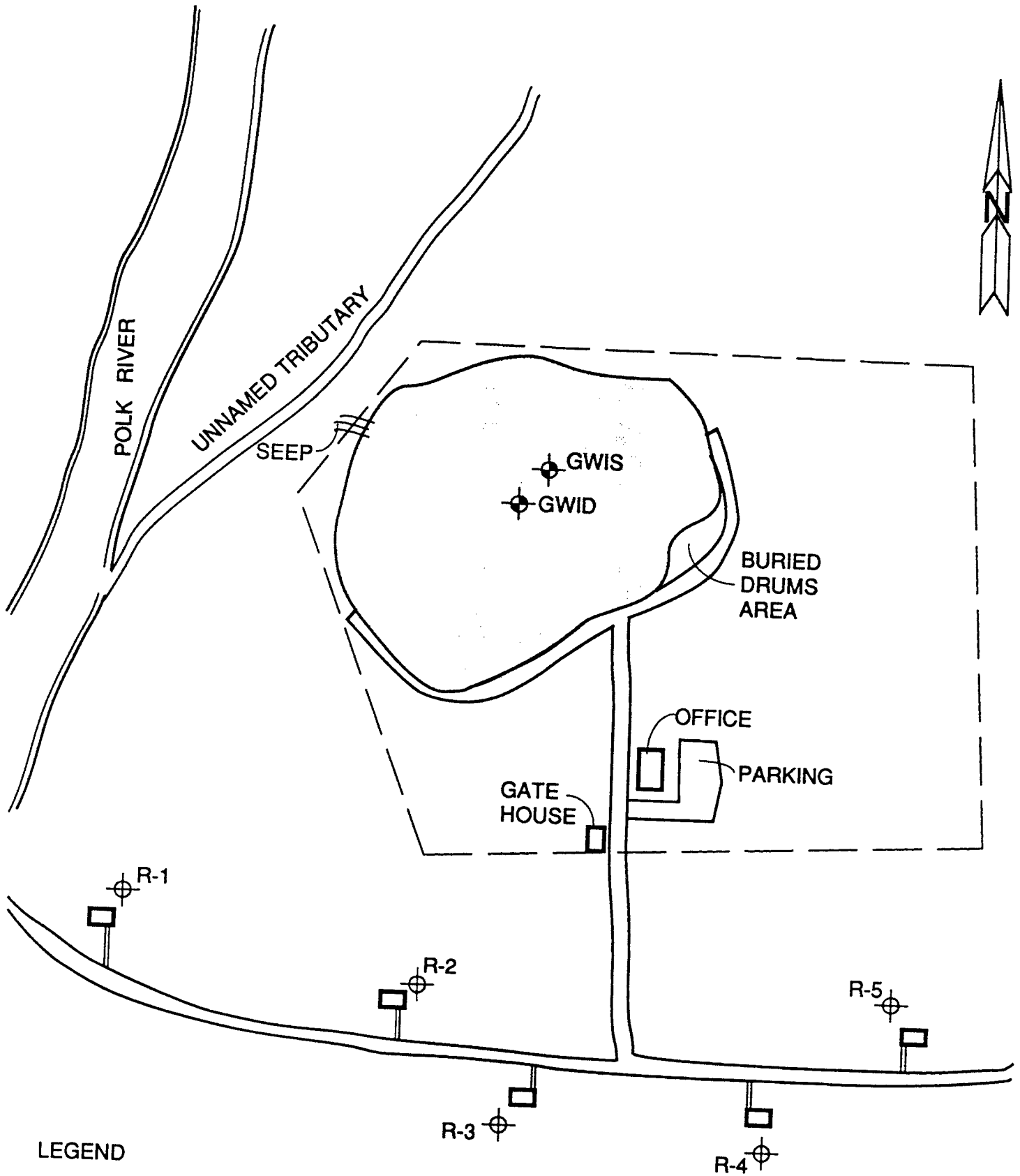

LEGEND

- ⊕ RESIDENTIAL WELLS
- ⊕ MONITORING WELLS

**Figure 2-1
SITE PLAN
EXAMPLE SITE**

stored in 55-gallon drums, which were left or buried at the site if they were damaged or leaking or could not be easily emptied. A large number of drums were also buried in the southeastern portion of the landfill.

In 1971, the site began receiving paint, paint thinners, paint residues, lacquers, plating sludges, and industrial process sludges. In 1975, a Consent Order issued by the County Circuit Court prohibited the disposal of these materials.

In 1979, the state sampled nearby domestic wells for compliance with drinking water standards. The investigations indicated that groundwater contamination had occurred and as a result the landfill was ordered to stop its operation in 1980. Between 1980 and 1981, closure plans were prepared by a contractor hired by the owner. Wells, shown by Figure 2-1, were drilled to the base of the landfill content to provide data for the closure scenarios. In 1981, a partial cap, consisting of 2 feet of compacted clay, was placed over the southeastern half of the landfill to cover major areas of exposed wastes and the liquid solvent disposal area. The remaining portion of the landfill previously had been covered with soil from an unknown source.

Investigations by FIT in 1986 indicated elevated levels of volatile organic compounds (VOCs) and metals in groundwater samples taken from nearby residential wells. Elevated levels of methane gas were also found. To date the primary contaminants of concern have been 1,1-dichloroethene (1,1-DCE), cis-1,2-dichloroethene (cis-1,2-DCE), tetrachloroethene (PCE), 1,1,1-trichloroethane (1,1,1-TCA), trichloroethene (TCE), vinyl chloride (VC), toluene, ethylbenzene, bis(2-e/h)phthalate, polychlorinated biphenyls (PBCs), lead, arsenic, and total chromium.

This appendix outlines the technical approach and associated activities to complete the RI/FS for the site. It is based on data gathered by the state and by FIT. These data were analyzed to develop the conceptual site model, identify additional data needs, and determine the scope of the RI/FS activities. The site received a Hazard Ranking Score of 30.0 which exceeded the 28.5 scoring and therefore was

high enough to be proposed for the NPL.

Limited field investigations were conducted by the remedial contractor in 1988 to provide data needed to fully scope the RI. Detailed discussions of these investigations are in Section 3.

2.3 Regional and Site-Specific Geology

The following sections describe the regional and site-specific geology of the area.

2.3.1 Regional Geology

The example site lies within the lower valley of the James River Basin, which was a major glacial drainage way across the “driftless area” to the Mississippi River. Consequently, the site contains thick deposits of unpitted outwash comprising of stratified sand and gravel to an estimated depth of 135 feet. Bedrock in the James River Basin consists mainly of sedimentary rock of Cambrian and Ordovician ages. Sandstone is predominant, but the Prairie du Chien Group and Galena-Platteville units are primarily dolomite and limestone, respectively. The greatest thickness of Cambrian and Ordovician rock, approximately 1,700 feet, occurs in the southern tip of the basin where the youngest bedrock formations cap high ridges. The Cambrian sandstone has a broad outcrop area because it is nearly flat lying and has been exposed by erosion as indicated by Soil Conservation data for this county.

Igneous and metamorphic crystalline rocks of Precambrian age form the basement and are the bedrock surface in the northern part of the basin.

Erosion of the sandstone and dolomite bedrock has occurred in this unglaciated region throughout geologic time. The erosion has cut numerous deep valleys into what was once a fairly level plateau forming a dissected upland with steep relief. In some parts of the county, the difference in elevation between the valley bottoms and the adjacent ridge tops is as much as 500 feet.

2.3.2 Site-Specific Geology

The soil underlying the example site belongs to the Plainfield series, which consists of fine to loamy fine sand, that are prevalent on alluvial terraces. This soil exhibits excessive drainage and is easily eroded by the wind.

The unconsolidated deposits at the site are approximately 135 feet thick and consist primarily of sand and gravel of glaciofluvial and alluvial origin. The site is located within an eroded bedrock valley that was filled with outwash transported by the James and Polk Rivers near the end of the Wisconsin Stage Glaciation. Atterberg limit tests were performed by the closure contractor on the surface silt and clay and results indicate that these strata are nonplastic. The hydraulic conductivity of the silt and clay was estimated to range from 1×10^{-3} to 1×10^{-6} cm/sec (Contractor, 1979). The other strata observed at the site consists predominantly of very fine to coarse sand with trace amounts of gravel, silt, and clay. The hydraulic conductivity of this strata was estimated to range from 1×10^{-2} to 1×10^{-3} cm/sec (Contractor, 1979).

Bedrock in the vicinity of the site consists of undifferentiated Cambrian sandstone up to 1,200 feet thick. This undifferentiated sandstone includes the St. Lawrence Formation, Jordan, Franconia, Galesville, Eau Claire, and Mount Simon Sandstones. These sandstones are fine to coarse-grained and contain a small amount of shale.

Bedrock was encountered at a depth of 134 feet in a residential well south of the site.

2.4 Hydrology

The location of the landfill in relation to the Polk River is critical in understanding the surface water-groundwater flow regime at the site.

2.4.1 Surface Water

The Polk River flows south-southwesterly to within 600 feet of the site. An unnamed tributary to the Polk River flows within 200 feet west of the site

(Figure 2-1). As the river flows past the site, its channel branches into channels that are tributaries to the James River. The main channel of the James River flows southeast within 2 miles of the site. The James River is dammed approximately 4 miles south of the site, forming Lake Ohio (Figure 2-2). A leachate seep has been identified that flows from the western position of the toe of the landfill to the unnamed tributary of the Polk River.

2.4.2 Groundwater

Groundwater flow directions were determined on the basis of water levels at nearby residential wells completed in the unconsolidated deposits of sand and gravel, and one existing monitoring well nest completed to the base of the landfill. These water levels have been measured quarterly since 1979. Horizontal groundwater flow is to the south-southwest for the majority of the year. However, during the spring runoff period the flow is altered, and groundwater flows to the south-southeast away from the river.

The horizontal groundwater gradient, calculated from available quarterly data during the period 1979 to 1986, ranged from 2.2×10^{-3} to 2.2×10^{-4} and averaged 5.3×10^{-4} , remaining relatively flat throughout the year. This variation in horizontal groundwater gradients is a result of seasonal variation associated with spring runoff. Vertical groundwater gradients measured during the investigation indicate that there is a slight downward gradient of 1×10^{-2}

2.4.3 Surface Water-Groundwater Relationship

A review of the measurements of groundwater level indicates that the direction of groundwater flow displays variation. The groundwater flow regime at the site is predicated on the seasonal surface water fluctuations in the Polk and James Rivers. These fluctuations are directly related to the Polk River and Lake Ohio, which either recharges the adjacent sand-and-gravel aquifer or receive groundwater discharge as the river and lake levels fluctuate. During the majority of the year, groundwater is discharging to the river, however, during spring runoff, when surface water levels are high, the river recharges the sand-and-gravel aquifer. This

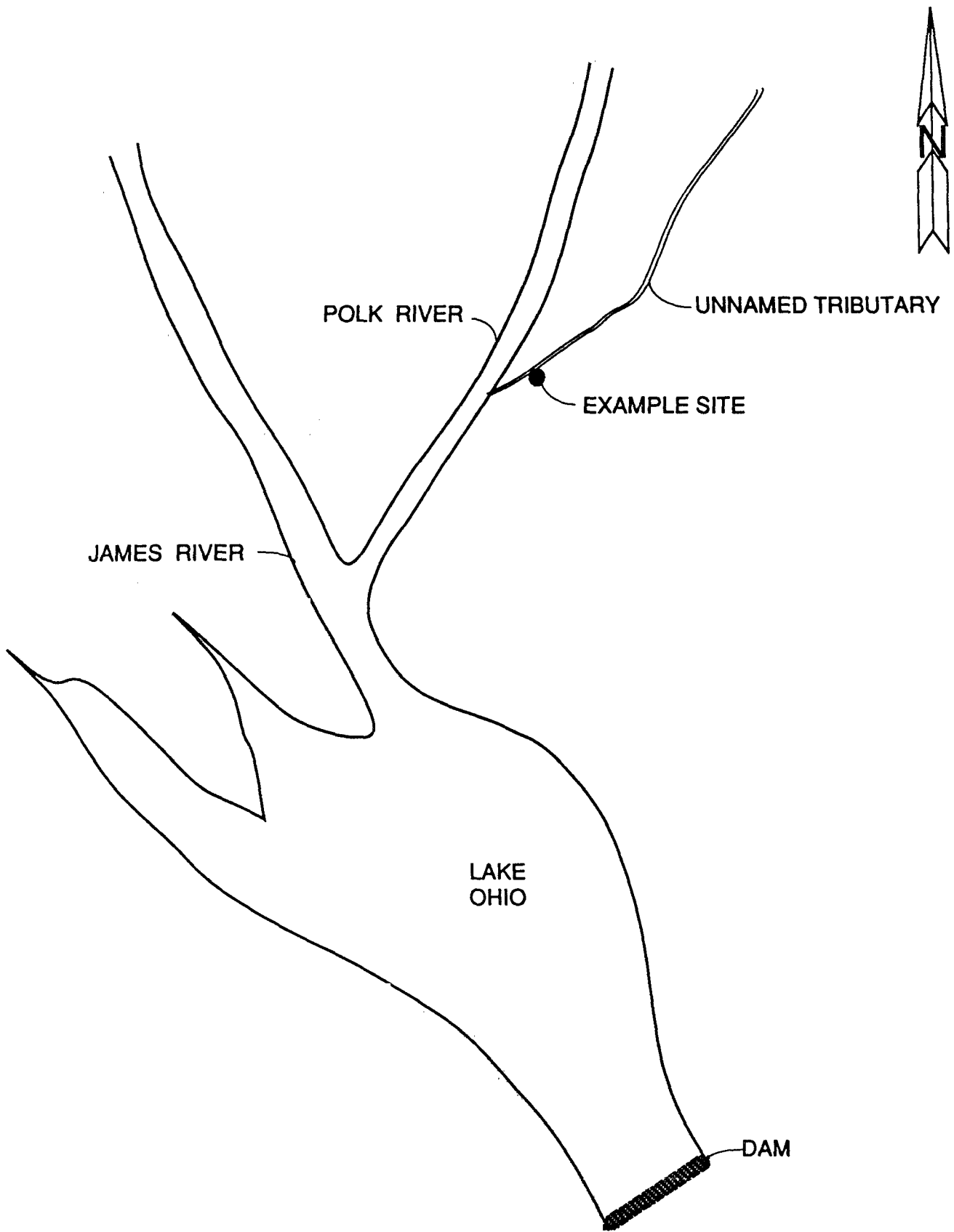

Scale:
1"=5280 ft.= 1 mile

Figure 2-2
SURFACE WATER FOR
EXAMPLE SITE

modifies the direction of groundwater flow from the south-southwest to the south-southeast, away from the river.

2.5 Hazardous Materials Characterization

Since landfill operations began, the 20-acre landfill had received a variety of municipal, commercial, and industrial wastes. Landfill records (gate slips) kept by the operators identified the waste haulers, indicated whether or not the delivery was a municipal or industrial waste, and listed the approximate quantities deposited. The gate slips did not provide waste descriptions nor did they include deliveries that occurred outside of the landfill operating hours. Consequently, a complete inventory of the wastes disposed of at the landfill is not available. Other records, however, from the county, the state, EPA, and past employees of the landfill were used to develop a partial list of the waste deposited at the landfill. Waste disposed at the site consisted primarily of solid waste, including paint cans, bottles, plastic, paper, degreasers, and other commercial and municipal garbage. The wastes of concern generally consisted of chlorinated and nonchlorinated organics, water-based and oil-based paints, paint thinners and lacquers, waste oil, automobile and household batteries, and industrial process sludges.

Available records show no indication of segregation of wastes. Industrial, commercial and municipal wastes are generally mixed throughout the fill area except for liquid industrial solvent wastes. In 1971, the state restricted disposal of the liquid industrial waste to the southern portion of the landfill. The wastes were generally buried as soon as it was received and the cover material compacted.

2.5.1 Source Description

Records indicate that a nearby electroplater contributed the greatest quantities of liquid wastes, consisting primarily of naphtha-based solvents used in the metal-cleaning process and wastes from paint spray and machine shop cleaning fluids. Paint residues and solvents were also delivered to the

landfill in 55-gallon drums. These drums were buried intact at the site if the drums could not be easily emptied or if they were damaged or leaking. A large portion of the drums were buried in the southeast portion of the landfill. There are no other known industrial liquid wastes at the site.

2.5.2 Waste Description

Review of existing records suggests that various industrial process sludges brought to the facility may have contained high concentrations of inorganics such as chromium, arsenic, and lead. Review of existing records also suggests that waste solvents also were brought to the site. Waste solvents consisted primarily of naphtha, toluene, ethanol, and paint residues. The naphtha-based solvents were primarily mineral spirits, which are the least volatile of the naphthas. Mineral spirits are a watery, colorless liquid with a gasoline-like odor. Their components are slightly soluble in water. Records indicate that waste ethanol (ethyl alcohol) brought to the site had previously been used as a solvent for resins, oils, hydrocarbons, surface castings, and cleaning preparations. Ethanol is a colorless, volatile liquid with a pungent taste. It has an ethereal, wine-like odor and is miscible in water.

The records also suggest that the solvent components of the paint wastes include highflash petroleum and toluene. Toluene is a methylbenzene (C_7H_8), which is a colorless, mobile liquid with a distinct aromatic odor and is immiscible in water.

2.6 Cap Characterization

In 1980, the state ordered the landfill closed. The owner then hired a contractor to prepare a closure plan for the landfill. In early 1981, closure investigations indicated that a partial cap was required over the southern portion of the landfill where the industrial liquid solvent wastes were buried and where there were areas of exposed wastes. In 1982, the owner submitted a closure plan to the state indicating that a cap, consisting of 2 feet of compacted clay with 6 inches of topsoil, was to be placed over the southern portion of the landfill. The remaining portion of the landfill had been

previously covered with soil from an unknown source (Figure 2-3).

As-built or final grading plans for the clay cap are not known to be available. The existing cap was visually observed for cracking and erosion during an inspection that was performed during the site visit. There were no major signs of cracking or failure of the existing clay cap, however, there was some minor sideslope erosion.

2.7 Description and Results of Past Sampling and Analysis Activities

Organic and inorganic data, shown in Table 2-1 (well locations shown in Figure 2-1), are available for five residential wells near the site and two onsite monitoring wells installed by the owner of the landfill for closure investigations in 1981. All wells are completed in the unconsolidated deposits of sand and gravel. Based on drillers' logs, the five residential wells range in depth from 45 to 58 feet and are completed as open-end steel pipes. Monitoring well GWIS has an open interval from 36 to 46 feet and GWID has an open interval from 62 to 72 feet. Both monitoring wells are PVC with the open interval being slotted PVC.

The site has a variety of organic contaminants in the groundwater and soil that appear on the Target Compound List (TCL) and the Target Analyte List (TAL), including VOCs such as TCE and VC; semivolatile organic compounds such as bis(2-e/h)phthalate and phenol, and metals such as

lead, arsenic, and chromium. VOC concentrations were highest at the southeast corner of the landfill. Methane gas was detected at concentrations above the lower explosive limit at the eastern end of the landfill. Low levels of VOCs were found in all of the residential wells. These wells are all located to the south of the site.

Sampling of the seven wells was conducted by the contractor hired by the owner and the analysis was done by a private laboratory not participating in the Contract Laboratory Program. The QA/QC procedures of the sampling and analysis are not readily available. Sample analysis methodologies were inappropriate for some contaminants; the detection limit for VC in groundwater was above the maximum contaminant level (MCL) of 2 ppb. Therefore, conclusions with regard to health risks for this contaminant cannot be made because the choice of analytical methods and reliability of the groundwater data are suspect. For purposes of this work plan, the above data will be used only for project planning and to identify preliminary remediation goals.

Only limited conclusions can be drawn from the existing data. The full areal and vertical extent of groundwater contamination can not be determined because all of the wells sampled showed VOC contamination. Well R-5, however, did not show exceedances, of primary MCLs. The depth of contamination, and the extent of contaminant migration to the south and west of the site have not been determined. Upgradient concentrations are also unknown. These data gaps need to be filled in the RI.

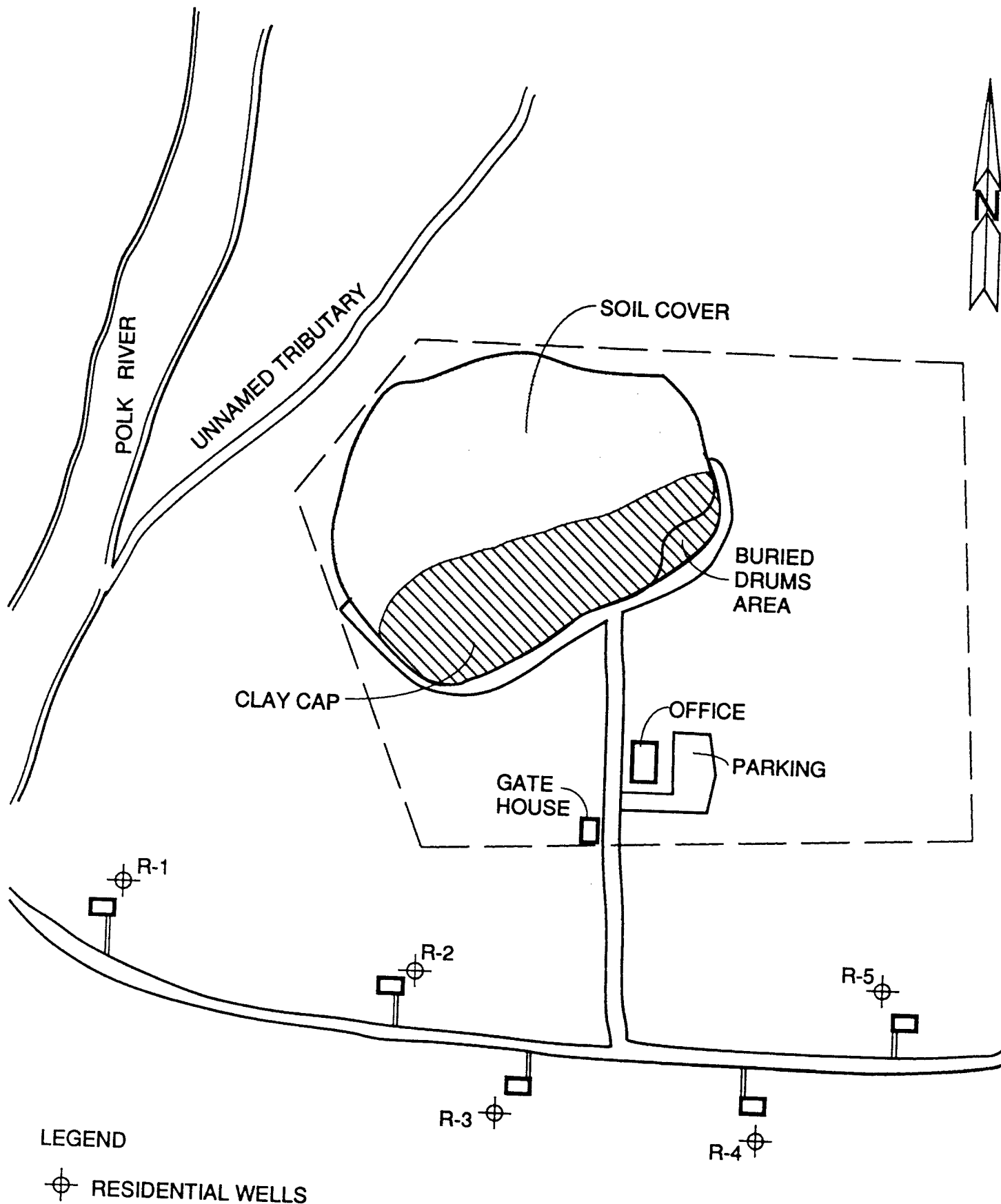

**Figure 2-3
LOCATION OF EXISTING CAP
EXAMPLE SITE**

**Table 2-1
SUMMARY OF GROUNDWATER SAMPLING AND ANALYTICAL RESULTS^a
(Fg/l)**

Contaminant	Residential Wells					Onsite Wells	
	(R-1)	(R-2)	(R-3)	(R-4)	(R-5)	(GWIS)	(GWID)
1,1-DCE	2.0	2.0	9.9	3.2	<5	8.5	4.5
cis-1,2-DCE	11.0	13.0	17.0	15.0	NA	16.0	10.0
PCE	2.6	3.3	33.5	3.9	<5	28.9	18.6
1,1,1-TCEA	36.0	36.0	90.0	5.5	<5.0	85.0	40.0
TCE	72.0	120.0	100.0	100.0	2.3J	110.0	75.0
VC	<5.0	<5.0	5.1	5.3	<5.0	55	4.2
Toluene	1,100	980	1,020	640	400	5,000	1,500
Ethylbenzene	700	850	920	200	200	10,500	500
bis(2-e/h)phthalate	820	640	580	120	45	980	780
Lead	17.3	<1.0	1.3 ^b	<1.9	NA	16.5	14.0
Arsenic		2.9	<4.0	2.7	3.2	NA	3.2
Total Chromium	7.0	17.0	27.0	<5.0	<5.0	25.1	18.2

^aSamples were collected in January 1981 as part of a closure investigation conducted by the contractor hired by the owner.

^bEstimated value.

Section 3

SITE DYNAMICS

Understanding the dynamics between the site and its environs including potential receptors, is essential to successfully scoping the RI/FS. This section discusses the limited field activities conducted during development of this work plan to better understand the site dynamics; the conceptual site model describing the site's dynamics; and the preliminary remediation goals that have been developed as a result of this information.

3.1 Limited Field Investigation

Insufficient data were available to adequately define the dynamics at the site and, hence, to develop the conceptual site model and design the RI program. Therefore, a limited field investigation was performed to collect data to further determine the RI scope. Prior to the limited field investigation, a site visit was conducted. The general features of the landfill were observed and documented. The perimeter of the landfill itself was identified, along with access and egress to and from the site. Nearby residents were interviewed, and photographs were taken. During the site visit, data on VOCs, radioactivity, and explosivity hazards were obtained using field analytical equipment (the HNu, radiation meter, and explosimeter) to determine appropriate health and safety levels. Site conditions differing from those reported in existing reports were also documented.

A summary of the limited field investigation objectives, activities, and results are shown by Table 3-1. The limited field investigation was conducted for several reasons. The site boundaries were not defined and maps of the site were not available. Reports indicate that there are seven onsite wells. Two of the existing wells, GWIS and GWID, were located during the site visit. The other five wells could either not be located during the site visit or the limited field investigation or were unusable. The viable well nest (GWIS and GWID) penetrates through the landfill contents.

In-situ hydraulic conductivity tests were conducted by the RI contractor in May, 1988, on three (R1, R2, and R3) of the five residential wells and the one onsite well nest (Figure 2-1). Based on the results of these tests, the hydraulic conductivity of this sand-and-gravel aquifer ranges from 9.8×10^{-3} cm/sec to 2.1×10^{-1} cm/sec with a geometric mean of 7.4×10^{-2} cm/sec. Table 3-2 summarizes results of the in-situ hydraulic conductivity testing. In general, this aquifer is very transmissive. This information aids in the placement of the new monitoring wells and provides an early indication of contaminant migration.

Water level measurements were taken from the nearby residential and onsite wells. The water level at the onsite well was slightly higher than the other wells, indicating a possible local groundwater mound.

3.2 Conceptual Site Model

Figure 3-1 summarizes the conceptual site model for the example site. The entire landfill will be considered as the source of the contaminants; however, disposal records indicate that high levels of VOCs are present in the waste disposed of primarily in the southeastern corner (solvent drums and liquid solvents) of the landfill.

Table 3-3 shows the preliminary exposure pathways under current and future use at the site. Organics and inorganics are released from the landfill to the groundwater by leaching caused by compression and/or by percolation. The contaminated groundwater is used as an offsite water supply source. Leachate discharges via seeps to the small tributary of the Polk River. Landfill gas present at the landfill can migrate and pose on- and offsite fire and explosion hazards. Landfill gas can also become soluble in groundwater.

**Table 3-1
LIMITED FIELD INVESTIGATION OBJECTIVES FOR
THE EXAMPLE SITE**

Activity	Objectives	Action	Results
General Investigation	Delineate site boundaries, estimate uncertainties in boundaries.	Conduct property survey or identify property ownership from tax records.	Site boundaries defined.
	Evaluate present site conditions.	Visually inspect site for gas/fire/explosion damage, runoff pathways, leachate seeps, exposed wastes, cover conditions, access concerns.	No evidence of gas/fire/explosion damage was observed. Several areas of exposed wastes are present. Additionally leachate seepage from the landfill was observed. Runoff pathways to the unnamed tributary of the Polk River were located.
	Locate existing monitoring wells.	Perform a topographic survey and location and elevation survey of existing monitoring wells.	Two of the seven existing onsite wells were located.
	Evaluate site drainage patterns.	Perform a topographic survey.	Site drainage patterns were defined.
	Locate preliminary locations for new monitoring wells.	Perform a topographic survey.	Preliminary locations of new monitoring wells were determined.
	Locate surface waters, wetlands, sensitive environments.	Conduct site visit.	An unnamed tributary of the Polk River flows within 200 ft of the west side of the landfill.
	Evaluate site-capping conditions and surface water drainage.	Perform visual surface inspection with topographic maps.	Capping and drainage appeared to be in fair condition with minor sideslope erosion. Leachate was observed seeping from the side of the landfill.
	Initiate measurements of landfill settlement rate.	Install benchmarks.	Benchmarks installed; quarterly readings will be taken.
	Site preliminary locations for trailer, decon pad, and secured storage area.	Conduct site visit.	Locations were identified.
	Evaluate site access to water, utilities, and telephone.	Conduct site visit.	Water may be available near the site from an upgradient well; if not, water will need to be trucked to the site. Also, a utility pole and a telephone line are needed.

**Table 3-1
LIMITED FIELD INVESTIGATION OBJECTIVES FOR
THE EXAMPLE SITE**

Activity	Objectives	Action	Results
Geotechnical Investigation	Describe geologic features, classify soil.	Conduct visual observation of mechanical erosion, slope instability, and ponding caused by subsidences and cracking.	Minor sideslope erosion of the cap was observed.
Hydrogeologic Investigation	Evaluate usefulness of existing monitoring well network.	Determine accessibility of existing wells. Determine, by sounding to the bottom of the well, if existing wells are obstructed.	Five of the seven wells could not be found; however, one well nest was located. Of the two wells located, both were judged suitable for future sampling.
	Reviews preliminary locations for new monitoring wells.	Review topographic map and conduct site survey.	Preliminary locations for new monitoring wells were observed.
	Conduct well inventory: determine local groundwater uses and construction of wells.	Perform well survey for all wells (residential, commercial, industrial) adjacent to, and downgradient from, the landfill. Obtain permission for use.	The majority of the residential wells are in use and information regarding their construction exists. There were no commercial or industrial wells identified.
	Confirm direction of groundwater flow and estimate gradients.	Record water level measurements from existing wells.	A monitoring well located in the landfill showed a slight water-level elevation compared to other wells, indicating the possibility of a local groundwater mound.
	Determine rate of groundwater flow in strata and bedrock fractures.	Perform hydraulic conductivity tests on existing wells.	Permeability of hydrogeologic units was estimated; rate of groundwater flow was calculated; groundwater extraction seems feasible.
	Estimate interaction between groundwater and surface water.	Conduct an investigation of the unnamed tributary on foot to determine if there is groundwater infiltration.	It appears that the groundwater is recharging the unnamed tributary.

**Table 3-2
RESULTS OF IN-SITU HYDRAULIC CONDUCTIVITY TESTS**

Well Number	Test Number	K	Geometric Mean
R1	1	2.1×10^{-1} cm/sec	1.8×10^{-1} cm/sec
	2	1.9×10^{-1} cm/sec	
	3	1.5×10^{-1} cm/sec	
R2	1	4.8×10^{-2} cm/sec	4.7×10^{-2} cm/sec
	2	4.2×10^{-2} cm/sec	
	3	5.1×10^{-2} cm/sec	
R3	1	3.0×10^{-2} cm/sec	3.0×10^{-2} cm/sec
	2	3.2×10^{-2} cm/sec	
	3	2.9×10^{-2} cm/sec	
GWIS	1	9.5×10^{-2} cm/sec	1.0×10^{-1} cm/sec
	2	9.5×10^{-2} cm/sec	
	3	1.1×10^{-1} cm/sec	
GWID	1	1.2×10^{-2} cm/sec	1.1×10^{-2} cm/sec
	2	9.8×10^{-3} cm/sec	
Geometric Mean			7.4×10^{-2} cm/sec

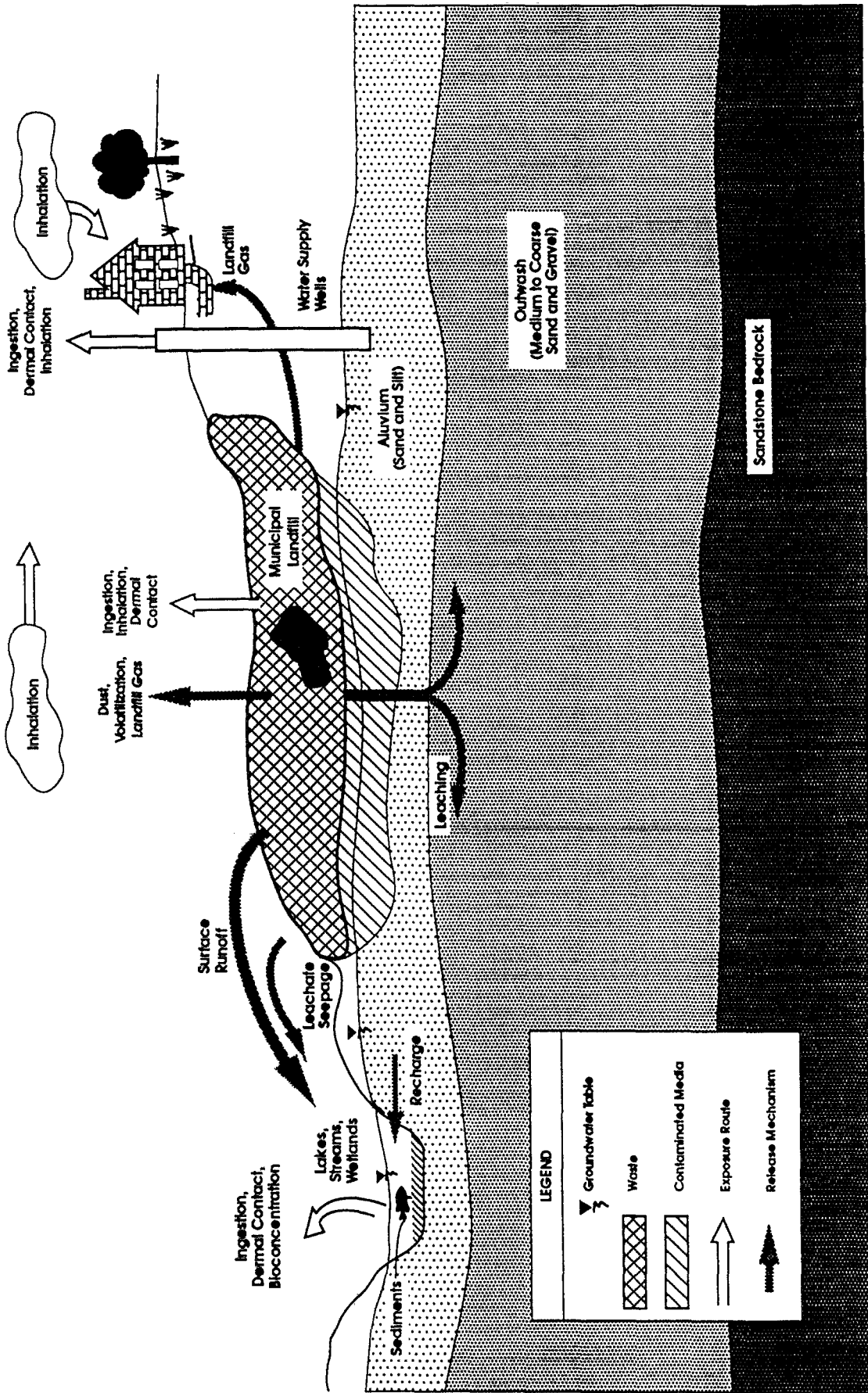

Figure 3-1
CONCEPTUAL SITE MODEL
EXAMPLE LANDFILL SITE

**Table 3-3
PRELIMINARY POTENTIAL EXPOSURE PATHWAYS UNDER CURRENT AND
FUTURE USE FOR THE EXAMPLES SITE**

Source	Release Mechanism	Transport Medium	Exposure Point	Exposure Route	Potential Receptors	Exposure Potential	Pathways Retained	
							Existing	Potential
Chemicals in fill and/or in drums	Erosion	Direct Contact	Onsite	Ingestion Dermal Absorption	Site workers Future site workers Trespassers	Exposed wastes in southeast section of landfill.	Yes	No, if covered
	Excavation	Direct Contact	Onsite	Ingestion Dermal Absorption Inhalation	Site workers Future site workers	Landfill not likely to be excavated in future. Land value is not expected to be high enough to justify expense of developing site.	No	No, if not excavated
	Leaching	Groundwater	Onsite	Ingestion Dermal Absorption Inhalation	Groundwater users	No current use of groundwater onsite. Potential for future use of onsite groundwater is minimal because of landfill.	No	No
	Leaching	Groundwater	Onsite	Ingestion Dermal Absorption Inhalation	Groundwater users	Use of sand and gravel aquifer. Wells could be installed in the future.	Yes	Yes
	Leaching	Leachate Seep	Stream	Bioconcentration Ingestion	Aquatic organisms	Depends on degree of attenuation and dilution.	Unknown	Yes
	Leaching	Leachate Seep	Stream	Ingestion of fish that bioconcentrated chemicals	People who consume fish	Depends on degree and frequency of exposure and amount ingested.	Unknown	Yes
	Leaching	Leachate Seep	Stream	Ingestion Dermal Absorption Inhalation	Recreational water users	Depends on dilution with surface water and degree of exposure.	Unknown	Yes
	Leaching	Landfill Gas	Onsite	Inhalation Explosion	Site workers Future site workers	Potential exists for migration into the groundwater. Potential for exposure during site investigation.	Yes	Yes
	Leaching	Landfill Gas	Onsite	Inhalation Explosion	Residents Area workers	Potential exists for migration into the groundwater.	No	Yes

Receptors at the site include site workers, future site workers, trespassers, residents, and area workers. Site workers, future site workers, and trespassers can make dermal contact with the exposed wastes. Residents and area workers can come into contact with the groundwater through ingestion, inhalation, and/or dermal contact; and with landfill gas through inhalation. Explosion is also a concern for landfill gas.

3.3 Preliminary Exposure Assessment

Exposure pathways must be identified in order to adequately define the preliminary remediation goals. Exposure pathways describe how a chemical can move from its source to a receptor. Components of an exposure pathway include a contaminant source, release mechanism, and the transport, migration, and fate of the contaminant.

3.3.1 Chemicals Previously Detected at the Site

The known types of waste disposed of at the landfill and their chemical characteristics are briefly discussed in Section 2.5.2 of this appendix. Chemical analytical data for these compounds are, however, available only for a limited set of contaminants. The type of contaminants and levels detected in the groundwater are shown by Table 2-1. The contaminants detected are:

1,1-DCE	lead
PCE	arsenic
1,1,1-TCA	total chromium
TCE	ethylbenzene
cis-1,2-DCE	toluene
VC	bis(2-e/h)phthalate

3.3.2 Contaminant Source

The contaminant sources at the site are the wastes disposed of in the landfill. They include:

- Chemicals and drums containing chemicals distributed throughout the landfill
- A large number of drums disposed of in the

southeastern portion of the landfill

- The “designated area” where liquid solvent wastes were also dumped in the southeastern section of the landfill
- Media now contaminated by wastes (e.g., groundwater, possibly surface water, and sediments of the unnamed tributary)

3.3.3 Release Mechanism

The mechanisms for contaminant release at the site include:

- Leaching of contaminants into the groundwater
- Leachate seeps discharging to adjacent soils and surface water
- Erosion of cover material, exposing landfill contents so they are released by runoff

Release of landfill gas containing volatile organics

3.3.4 Contaminant Transport

The primary transport mechanisms are:

- Movement with groundwater
- Movement of leachate seeps
- Movement with surface water runoff
- Movement of landfill gas

Leaching of contaminants from the landfill materials has occurred as indicated by the groundwater contamination and the possible presence of a mound under the landfill. This is the release mechanism of greatest concern at the site because with no additional action, it has the potential to add the greatest amount of contaminants to the environment and to affect receptors via drinking water wells. Continued release, however, may occur from leaking drums, continued low-rate infiltration from contaminated soils, wastes in contact with the groundwater, or exposure of waste to surface runoff as a result of erosion. Migration of landfill gas is also of concern at the site because

of both explosion potential by a buildup of methane in enclosed spaces and air-quality degradation by volatile (vinyl chloride) carcinogens.

3.3.5 Contaminant Migration

After contaminants have entered the ground-water, several migration pathways are possible depending on their widely varying sorption characteristics. Shallow groundwater could migrate downgradient or to deeper aquifers and eventually to potential receptors offsite. Existing data indicate that the contaminant plume has moved offsite as evidenced by the contamination in the nearby residential wells.

Based on the hydraulic conductivities and gradients determined during the limited field investigations, and an estimated time of 20 years, groundwater recharge velocities were calculated. Most of the detected VOCs are expected to be found within approximately 1,000 feet of the site.

Contaminants in the leachate seeps may migrate offsite to the unnamed tributary to the Polk River. Potential receptors include aquatic and terrestrial organisms in the stream as well as human receptors who may consume fish from the stream or use the stream for recreational purposes.

Contaminants in the form of landfill gas may also migrate from the site seeking escape into the atmosphere. Microbial decomposition of organic wastes under anaerobic conditions produces a gas, which is generally 50 to 55 percent methane and 40 to 45 percent carbon dioxide.

3.3.6 Contaminant Fate

The following discussion describing the fate of contaminants detected in the study area is based on a review of literature and relevant site conditions.

VOCs were detected in groundwater within the landfill and in nearby residential wells. Under existing site conditions, the VOCs could be transported with groundwater, leachate seeps,

or surface-water runoff to surface waters. During transport in the groundwater, the contaminants may be subject to adsorption, hydrolysis, and biological degradation under aerobic or anaerobic conditions. Upon transport to surface water the chemicals may be adsorbed to sediments or taken up by aquatic organisms, and with exposure to aerobic conditions and sunlight, subjected to volatilization, biological transformation, hydrolysis, or photolysis. The primary mechanisms that affect the migration and fate of the organic compounds are: adsorption on sediments, volatilization, degradation, and uptake by aquatic organisms.

3.3.7 Exposure Pathways

The potential exposure pathways associated with the site are shown in Table 3-3. The major potential exposure pathways associated with the site are:

- Release of contaminant to the groundwater, contaminant migration through the groundwater, and exposure through use of the groundwater as a drinking water source
- Release of a contaminant from leachate seeps to surface water (stream) and the exposure to aquatic and terrestrial organisms in the stream
- Erosion of cover material and exposure of landfill contents leading to exposure of nearby residents, site workers, future site workers, future site users, trespassers, or terrestrial wildlife
- ! Landfill gas migration leading to fire and explosion and air quality degradation which can affect residents, area workers, site workers, and future site users

Identifying these exposure pathways aids in the development of the remedial action objectives and preliminary remediation goals, which are presented in Section 4.3 of this appendix.

Section 4

PRELIMINARY IDENTIFICATION OF REMEDIAL ACTION ALTERNATIVES

4.1 Potential ARARs for the Example Site

A description of the federal and state location-and action-specific ARARs for CERCLA municipal landfill sites can be found in Sections 5 and 6, respectively, of the body of this report (*Conducting Remedial Investigation/Feasibility Studies for CERCLA Municipal Landfill Sites*). Potential federal location-specific ARARs for the example site are presented in Table 5-2 in the body of this document; no state location-specific requirements (Section 6) were identified that were more stringent than the federal location-specific ARARs.

The most significant potential location-specific ARARs involve wetlands and floodplains. Although there are no wetland areas presently known to exist near the site, if any are discovered remediation will have to be implemented in a manner that minimizes the destruction, loss or degradation of the wetland areas (Executive Order 11990, Protection of Wetlands--40 CFR 6, Appendix A). Additionally, the Clean Water Act Section 404 prohibits discharge of dredged or fill material into a wetland area without a permit. If it is determined that the example site is within the floodplain of the Polk River, then remediation will have to avoid adverse effects and preserve natural and beneficial values of the floodplain (Executive Order 11988, Protection of Floodplains--40 CFR 6, Appendix A).

Potential federal action-specific ARARs are presented in Table 5-3 in the body of this document. The most significant action-specific ARAR will be in compliance with RCRA closure requirements. At a minimum, remediations will have to comply with RCRA subtitle D closure requirements. Compliance with RCRA Subtitle C requirements will be necessary if it is determined to be applicable or relevant and appropriate. Subtitle C will be applicable if the results of the RI indicate that the waste in the southeast corner of the landfill contains

RCRA characteristic or listed waste and that the response action for those wastes constitutes treatment, storage, or disposal as defined by RCRA. A determination of relevance and appropriateness will depend on a number of factors, including the nature of the waste, its hazardous properties, and the nature of the requirement itself. Since it is probable that a cap will be constructed at the example site, compliance with state cover design requirements will be necessary. The state requires sufficient freeze-thaw protection with minimum cover requirement including a 2-foot clay layer with a 1.5 to 2.5-foot cover layer and 0.5 foot of topsoil.

In situations where RCRA requirements are potential ARARs, disposal of contaminated soils will be influenced by the RCRA Land Disposal Restrictions (LDRs). The LDRs may be applicable to contaminated soils if it is determined that the soils have been contaminated by a restricted, listed RCRA waste or if the contaminated soils are a RCRA characteristic hazardous waste. The LDRs may require that a specific concentration level be achieved or that a specified technology be used for treatment prior to offsite disposal at a RCRA facility.

Some of the alternatives for the example site may include technologies that result in discharge of contaminants to the air. Technologies that typically result in air emissions include air stripping, collection and treatment of landfill gas, excavation and consolidation of contaminated soils; and incineration. Table 5-3, in the body of this document summarizes the requirements concerning air emissions for these technologies, which may be implemented at the example site.

State and federal chemical-specific ARARs (e.g., MCLs, state groundwater enforcement standards) will have to be complied with when

determining appropriate cleanup levels for groundwater. The MCLGs, established under the Safe Drinking Water Act, that are set at levels above zero, should be attained by remedial actions for ground or surface waters that are current or potential sources of drinking water. Where the MCLG for a contaminant has been set at a level of zero, the MCL for that contaminant should be attained. More stringent state standards that have been promulgated, are identified in a timely manner, and have been applied consistently by the state, will have to be attained unless a waiver is used. Tables 4-1 through 4-4 of this appendix present the potential chemical-specific ARARs for the example site. Water quality criteria have been included in the tables along with drinking water standards since it is likely these criteria would be the basis for establishing discharge requirements for discharges to the unnamed tributary to the Polk River.

4.2 Review of Analytical Results and Comparison to ARARs

Table 2-1 in this appendix provides a summary of the groundwater sampling and analytical results for both residential and onsite wells. The sampling data for these seven wells are described as not being of CLP quality, with QA/QC procedures not available, and with a detection limit higher than the MCLs for some chemicals. However, it is clear that all wells show some VOC contamination.

To show how the streamlined approach described in Section 3.7.2 of this document may suggest that a certain remedial action (such as capping) be initiated, the contaminant concentrations actually detected in residential wells are compared to the ARARs for each contaminant. Because ingestion of groundwater is a direct exposure route, any contaminant concentration above its ARAR (federal non-zero MCLGs or MCLs) would indicate that remedial action is warranted. After comparing Tables 2-1 (contaminant levels in residential wells) and 4-1 (potential chemical-specific ARARs), it is obvious that several residential wells have contaminant concentrations above ARARs,

particularly well R-3 where 1,1-DCE, PCE, TCE, VC, and ethylbenzene concentrations are all above their federal MCLs. Therefore, based on this review of preliminary groundwater data, the following conclusions can be made to expedite remediation:

1. Initial RI fieldwork should include obtaining data that can be utilized to make this comparison and determination. If validated RI data confirms that contaminant levels in residential wells clearly exceed ARARs, remediation to address contamination in residential wells as an early action or interim action is warranted.
2. Based on the volume and heterogeneity of waste within the landfill, capping can be identified as the only practicable alternative for the landfill contents (discussed in Section 4.4.1). Therefore, in order to reduce the continued contaminant loading to groundwater capping alternatives for the example site may be evaluated as an early action.

A more thorough quantitative baseline risk assessment is required for other exposure pathways since there is not clear exceedance of ARARs. These areas include risks associated with hot spot areas, landfill gas, and surface water and sediments.

4.2.1 Baseline Risk Assessment

The approach described above for the baseline risk assessment of the example site deals only with residential groundwater data, ingestion of groundwater as the route of exposure, and comparison to federal MCLs for the toxicity assessment. The purpose is to expedite remediation of groundwater since ARARs appear to be clearly exceeded. A more thorough baseline risk assessment, considering all potential exposure pathways for both human and environmental exposure, will be necessary to show that the final remedies will protect human health and the environment. The following documents provide guidance regarding more thorough baseline risk assessments:

**Table 4-1
POTENTIAL FEDERAL CHEMICAL-SPECIFIC ARARs FOR THE EXAMPLE SITE^a**

Chemical^b	MCL µg/l	MCLG µg/l	Secondary MCL µg/l
Trichloroethylene	5 final 1987	0 proposed 1985	N/A
Vinyl Chloride	2 ^c final 1987	0 ^d final 1985	N/A
1,1-Dichloroethylene	7 final 1985	7 final 1985	N/A
cis-1,2-Dichloroethylene	70 ^e proposed 1989	70 ^e proposed 1989	N/A
Benzene	5 final 1987	0 final 1985	N/A
Ethylbenzene	700 ^e proposed 1989	680 proposed 1985	30 ^e proposed 1989
Toluene	2,000 ^e proposed 1989	2,000 ^e proposed 1985	40 ^e proposed 1989
Xylenes (total)	10,000 ^e proposed 1989	440 proposed 1985	20 ^e proposed 1989
Tetrachloroethylene	5 ^e proposed 1989	0 proposed 1984	N/A
1,1,1-Trichloroethane	200 Final 1987	200 Final 1985	N/A
Bis(2-ethylhexyl)phthlate	N/A	N/A	N/A
Lead	50 ^{f,g}	20 ^f	N/A
Arsenic	50 ^g	50 proposed 1985	N/A
Chromium III	50 ^{g,h} final 1986	120 ^h proposed 1985	N/A
Chromium VI	50 ^{g,h} final 1986	120 ^h proposed 1985	N/A
Copper	1,300 proposed 1988	1,300 proposed 1988	1,000 ^e proposed 1989
Mercury (Inorganic)	2 ^e proposed 1989	2 ^e proposed 1989	N/A
Manganese	N/A	N/A	50
Iron	N/A	N/A	300

^aSource, unless otherwise note - Integrated Risk Information System (IRIS), March 1990

^bSome of the ions that may be used for plume mapping at the example site (e.g., chloride, sodium, sulfate) do not have chemical-specific ARARs associated with them. These parameters are being analyzed for use as conservative indicators in determining the extent of groundwater contamination.

^cFederal Register 45 CFR (141)

^dU.S. EPA Health Advisories

^eFederal Register 54 CFR (97)

^fFor water entering the distribution system, not at the tap

^gFederal Register 40 CFR (141)

^hProposed 100 µg/l for total chromium (III and VI), 54 CFR (97)

ⁱFederal Register 53 (160), 8/18/88

N/A = not available

**Table 4-2
POTENTIAL FEDERAL CHEMICAL-SPECIFIC TBCs FOR THE EXAMPLE SITE ^a**

Chemical ^e	Ambient Water Quality Criteria				Oral Reference Dose mg/kg-day	Health Advisory Longer Term Adult and Children µg/R	Cancer Classification	Oral Potency (mg/kg-day) ⁻¹
	Human Health		Aquatic Organisms (Freshwater)					
	Water & Fish µg/R	Fish Only µh/R	Acute LC µg/R	Chronic LC µg/R				
Trichloroethylene	2.7 10 ⁻⁶ cancer risk	80.7 10 ⁻⁶ cancer risk	45,000	None	0.00735 ^b	No suitable data	B2 ^c	0.011 ^e
Vinyl Chloride	2 ^d 10 ⁻⁶ cancer risk	525 ^d 10 ⁻⁶ cancer risk	--	--	--	46 ^b	A ^b	2.3 ^b
1,1-Dichloroethylene	0.033 10 ⁻⁶ cancer risk	1.85 10 ⁻⁶ cancer risk	11,600	None	0.009	3,500 ^b	C	0.6
cis-1,2-Dichloroethylene	--	--	--	--	0.01 ^b	3,500 ^b	D	None
Ethylbenzene	1,400	3,280	32,000	None	0.1	3,400	D	None
Toluene	14,300	424,000	17,500	None	0.3 (assume 0.5 absorption factor)	3,460 ^b	D	None
Xylene (total)	--	--	N/A	N/A	2	27,300 ^b	D	None
Tetrachloroethylene	0.8 10 ⁻⁶ Cancer Risk	8.85 10 ⁻⁶ Cancer risk	5,280	840	0.01	5,000	Pending	N/A
1,1,1-Trichloroethane	18,400	1,030,000	None	None	0.09 (assume 0.3 inhalation retention factor)	125,000 ^c	D	None
Bis(2-ethylhexyl)phthalate	1.75 ^e	5.88 ^e	940	3	0.02	N/A	B2	0.014
Lead	50	N/A	82	3.2	Inappropriate	N/A	B2	N/A
Arsenic	0.0022	0.175	360	190	Pending	N/A	A	1.5 ^f
Chromium III	170,000	3,433,000	980	120	1	840	N/A	N/A
Chromium VI	50	N/A	16	11	0.005	840	A by inhalation only	N/A
Benzene	0.66 10 ⁻⁶ cancer risk	40 10 ⁻⁶ cancer risk	5,300	None	Pending	Not calculated due to carcinogenicity	A	0.029 from inhalation data
Copper	--	--	6.5 ⁱ	--	--	--	D	None

**Table 4-2
POTENTIAL FEDERAL CHEMICAL-SPECIFIC TBCs FOR THE EXAMPLE SITE ^a**

Chemical ^a	Ambient Water Quality Criteria				Oral Reference Dose mg/kg-day	Health Advisory Longer Term Adult and Children µg/R	Cancer Classification	Oral Potency (mg/kg-day) ⁻¹
	Human Health		Aquatic Organisms (Freshwater)					
	Water & Fish µg/R	Fish Only µh/R	Acute LC µg/R	Chronic LC µg/R				
Mercury	--	--	4.857 ^h	1.302 ^h	--	--	D	None

^aSource, unless otherwise noted - Integrated Risk Information System (IRIS), March 1990

^bU.S. EPA Health Advisories

^cEPA Health Effects Assessment Summary Tables (HEAST) Fourth Quarter FY 1989

^dFederal Register 45 (231)

^eInterim Addendum to DEHP Criteria

^fRisk Assessment Forum Document, 1988

^gSome of the ions that may be used for plume mapping at the example site (e.g., chloride, sodium, sulfate) do not have chemical specific ARARs associated with them. These parameters are being analyzed for use

as conservative indicators in determining the extent of groundwater contamination.

^hMercury (II). Ambient Water Quality Criteria for Mercury - 1984, EPA

ⁱAt a hardness of 50 mg/L Federal Register, Vol. 50 p. 30784, July 29, 1985

N/A - not available

LC - lethal concentration

--- = no value found

U.S. EPA Cancer Classification

Group A Human carcinogen -- sufficient evidence of carcinogenicity in humans

Group B1 Probable human carcinogen -- limited evidence of carcinogenicity in human

Group B2 Probable human carcinogen -- sufficient evidence of carcinogenicity in animals

Group C Possible human carcinogen -- limited evidence of carcinogenicity in animals

Group D Not classifiable as to human carcinogenicity -- there is no animal evidence, or human or animal evidence is inadequate

Group E Evidence of noncarcinogenicity for humans

**Table 4-3
STATE GROUNDWATER STANDARDS
FOR THE EXAMPLE SITE**

Chemical^a	Enforcement Standard^b (µg/l)	Preventative Action Limit^b (µg/l)
Arsenic	50	5
Chromium	50	5
1,2-dichloroethylene (cis)	100	10
1,1-Dichloroethene	0.24	0.024
Ethybenzene	1,360	272
Lead	50	5
Manganese	50	5
Selenium	10	1
Silver	50	5
Toluene	343	68.6
Tetrachloroethylene	1.0	0.1
1,1,1-Trichloroethane	200	40
Trichloroethene	1.8	0.18
Vinyl chloride	0.015	0.0015
Xylene	620	124
Zinc	5,000	2,500

^aChemicals are those to which state standards apply. Typically, there will not be state groundwater standards for all the chemicals detected in the groundwater.
^bThe list presented is based on a review of Wisconsin groundwater standards—NR 140.

**Table 4-4
STATE AMBIENT WATER QUALITY CRITERIA
FOR AQUATIC LIFE PROTECTION
FOR THE EXAMPLE SITE**

Chemical	State Water Quality Criteria ^a	
	Acute ^b Toxicity Criteria (ug/l)	Chronic ^c Toxicity Criteria (ug/l)
Arsenic ^d	363.8	153.0
Benzoic acid	--	--
bis-2-Ethylhexylphthalate	--	--
chromium(hexavalent) ^d	14.2	9.7
Chromium(trivalent)	3,301.1	95.4
1,1-Dichloroethene	--	--
1,2-Dichloroethene (cis)	--	--
Ethylbenzene	--	--
Tetrachloroethylene	--	--
1,1,1-Trichloroethane	--	--
Trichloroethene	--	--
Vinyl chloride	--	--
Xylenes	--	--

Notes:

^aBased on Wisconsin Water Quality Criteria for Protection of Freshwater Aquatic Life (Warm Water Sportfish Classification). From Wisconsin Administrative Code NR 105.

^bAcute Toxicity Criteria is the maximum daily concentration of a substance which ensures adequate protection of sensitive aquatic species and may not be exceeded more than once every 3 years.

^cChronic Toxicity Criteria is the maximum 4-day concentration of a substance which ensures adequate protection of sensitive aquatic species and may not be exceeded more than once every 3 years. CTC are based on acute/chronic toxicity ratios as defined in NR 105.06(5).

^dCriteria listed is applicable to the “total recoverable” form. Typically, state water quality criteria will not exist for all the contaminants found at the site.

- U.S. EPA. *Risk Assessment Guidance for Superfund--Human Health Evaluation Manual*, Part A. Interim Final. EPA/540/1-89/002. December 1989.
- U.S. EPA. *Risk Assessment Guidance for Superfund. Volume H. Environmental Evaluation Manual*. EPA/540/1-89/001. March 1989.

4.3 Preliminary Remedial Action Objectives and Goals

Preliminary remedial action objectives and goals have been developed for the example site to assist in identifying preliminary remedial action alternatives and RI data requirements. The remedial action objectives for the example site are as follows:

- Provide adequate protection to human health and the environment from direct contact or ingestion of the hazardous constituents in wastes or soil from landfill
- Provide adequate protection to human health and the environment from direct contact, ingestion, or inhalation of the hazardous constituents in groundwater beneath the landfill or groundwater that has migrated from the landfill
- Provide adequate protection to human health and the environment from direct contact or ingestion of the hazardous constituents in surface water and sediments of the unnamed tributary
- Provide adequate protection to human health from inhalation or explosion of landfill gases

Preliminary remediation goals were developed based on the remedial action objectives, existing data (Section 2.7), preliminary ARARs (Section 4.1), and the exposure assessment (Section 3.3). Because of the limited usability of the data (see Section 2.7), these goals will be revised as more information on the site becomes available. The preliminary remedial action goals are follows:

- Prevent ingestion of contaminated groundwater exceeding non-zero MCLGs or MCLs (where MCLGs are set at zero).
- Prevent direct contact with landfill contents and minimize continued contaminant loading to groundwater.
- Prevent direct contact and ingestion of contaminated soils from hot spot areas.
- Provide adequate protection to human health from inhalation or explosion of landfill gas. Potential collection and treatment requirements will be established based on an analysis of the data to be collected in the RI (including a risk assessment).
- Provide adequate protection to human health and the environment from direct contact or ingestion of contaminated surface waters or sediments of the unnamed tributary. Specific remediation requirements will be established based on risk after an analysis of the data to be collected in the RI.

4.4 Preliminary Remedial Action Alternatives

Several technologies and/or alternatives are unlikely to survive screening in the FS for technical, implementation, or cost reasons. As an example, the excavation of the landfill with subsequent treatment or disposal onsite or offsite is not a feasible alternative for the example site because of the substantial cost that would be associated with a landfill of this size (20 acres, or approximately 750,000 cubic yards), the significant health and safety concerns that would arise during excavation in areas of solvent disposal, and the potential for fire or explosion of the landfill gases. Likewise, containment of groundwater with a cutoff such as a slurry wall is not considered practicable because an aquitard does not appear to be present at the site. The following sections discuss the practicable remedial actions for the media of concern at the site.

As required by the NCP, the no-action alternative is included and involves no additional activities by EPA, thereby providing a baseline for evaluating other alternatives.

4.4.1 Landfill Contents

The most practicable remedial action alternative for this medium is containment with or without institutional controls. The containment alternatives might include: (1) regrading and revegetation of existing cap and implementation of institutional controls, (2) construction of a single-barrier cap with or without institutional controls, or (3) construction of a composite-barrier cap with or without institutional controls. The purpose of the first alternative would be to provide some protection against direct contact and would improve surface water drainage, thereby reducing infiltration. The second two alternatives would provide superior protection against further groundwater contamination by minimizing the potential for infiltration and would provide a barrier to prevent contaminated soil from eroding during precipitation events. Reducing infiltration and subsequent leachate generation would also mitigate leachate seeps. Capping can also provide gas control, particularly if implemented in conjunction with a gas collection system. A composite-barrier cap will be more effective and reliable in preventing infiltration than a single-barrier cap, however, both designs may satisfy applicable or relevant and appropriate requirements (ARARs). All three caps may be viable, depending on the remedial objectives and the results of the RI. The factors that may affect the type of cap to be used are presented in Figure 4-1 of the body of this report (*Conducting Remedial Investigations/Feasibility Studies for CERCLA Municipal Landfill Sites*). These alternatives could be used in conjunction with a fence and a restrictive covenant on the landfill property to prevent future site development.

If RI data indicate that landfill gas presents a hazard to human health and the environment, then deed restrictions may also be imposed on areas in the vicinity of the site to limit exposure to the landfill gas. Another measure may be to vent and treat the landfill gas as described in Section 4.3.4.

4.4.2 Hot Spots

The practicable alternatives for the contaminated soils in the southern portion of the site include: (1) excavation and disposal, (2) excavation, treatment, and disposal (onsite or offsite) of treated material, or (3) consolidation of hot spot areas under a landfill cap.

The first two alternatives would involve excavation, possible treatment, and disposal of the soil/waste in the solvent disposal area of the landfill. Both alternatives would protect against further contamination of the groundwater and surface water and against direct contact. Excavation could be accomplished using conventional construction equipment (e.g., backhoe); the risks to local residents and site workers during execution activities will be evaluated during the analysis of remedial action alternatives. Treatment of contaminated soil/waste, if necessary, would likely be done onsite (offsite treatment of soils from municipal landfill sites is rarely done because of availability and cost). The most viable onsite treatment options include incineration and solidification/stabilization. The most common type of incineration process is rotary kiln, but often the decision is made during design or by the remediation contractor based on performance criteria. Solidification/stabilization involves adding pozzolanic agents such as lime, cement, and fly ash to the soil/waste in situ or in a batch process. The selected treatment method may be largely dependent on whether the waste is a RCRA-restricted waste or not, and therefore whether the land disposal restrictions apply.

Disposal of excavated soil/waste should occur onsite and be incorporated under the landfill's final cover. All soil/waste treated onsite would probably be disposed of in the same place from which it was removed if the treated wastes are not considered RCRA wastes.

The required level of treatment of RCRA-restricted wastes before disposal is dependent on the RCRA land disposal restrictions (LDRs) that apply to the specific contaminant. In order to determine the level of treatment required, the process(es) generating the contaminants must be identified and the appropriate RCRA hazardous waste number determined.

In addition to information on the process that generated the hazardous waste, information needed to select a treatment and disposal option includes: the type and concentrations of contaminants in the soil, the volume of contaminated soil, the moisture content of the soil, and the soil type. Also, information on the types and population densities of resident micro-organisms suitable for biodegradation of contaminants may be needed if contaminant concentrations are sufficiently high. Potential exposures from dermal contact, entrainment of soil particles in air, and release of volatiles during remediation would be evaluated and necessary actions taken.

The third alternative for this area would be consolidation of the hot spots to reduce the area of the final landfill cap. This alternative is similar to the first alternative, except that, when a landfill cap is constructed, the hot spot areas would be included under the cap, or material from the hot spot areas would be excavated to the extent necessary to consolidate these materials under the landfill cap. This alternative would prevent direct contact with the contaminated soil and prevent contamination of surface water. Further contamination of groundwater would be reduced by preventing infiltration of runoff through the contaminated soil.

4.4.3 Groundwater/Leachate

The existing data shows that four of the five residential wells tested exceeded primary MCLs, as presented in Table 2-1 of this appendix. Practicable alternatives for groundwater remediation will include extraction, treatment, and disposal of the contaminated groundwater. The two strategies associated with groundwater extraction include placement of perimeter wells to capture leachate and placement of downgradient wells to capture contaminated groundwater that has migrated offsite. Leachate extraction wells in conjunction with a landfill cap may also be used to stop leachate seeps. Collection trenches are also an option for groundwater/leachate extraction; however, extraction wells are more likely to be used because of the depth of groundwater contamination.

Extraction, treatment, and disposal of contaminated groundwater would help stabilize the contaminant plume and provide for ground-water remediation.

Groundwater samples should also be analyzed to characterize the contaminant types and characteristics and the conventional parameters--such as hardness and iron content--needed to design a treatment system.

Extraction wells would be located in areas that would maximize the yield of contaminated groundwater. Perimeter wells could be placed around the landfill to capture leachate and provide a containment system to minimize offsite migration of contaminants via groundwater and leachate seeps. Placement of wells down-gradient within the contaminated plume would be used to remediate contaminated groundwater that has already migrated offsite. The extracted groundwater would then be treated before discharge, either onsite or at a POTW. The information needed to design a more comprehensive groundwater extraction system includes the chemical parameters associated with the contaminated plume and the hydraulic characteristics of the aquifer.

Either onsite or offsite treatment of contaminated groundwater will likely be feasible. Typically, leachate or high strength contaminated groundwater from municipal landfill sites will be high in concentrations of organic matter. Treatment is usually by conventional means such as biological treatment (e.g., activated sludge), physical treatment (e.g., granular activated carbon (GAC) or air stripping), and/or chemical treatment (e.g., metals precipitation).

Based on known data, onsite treatment might be accomplished using air stripping for VOC removal and/or GAC for removal of semi-volatile contaminants. Depending on the contaminants and their concentrations, GAC columns could also be used without air stripping to remove VOCs, as well as semi-volatile contaminants.

Average and peak flow rates and contaminant concentrations and properties would need to be identified to design the treatment system. Information on the hardness, biochemical oxygen demand (BOD), chemical oxygen demand (COD), total suspended solids (TSS), iron, and other conventional pollutant parameters would be needed as well in order to determine if other treatment processes (such as biological or

chemical treatments) are necessary in addition to, or as a replacement for, the air stripping and/or GAC treatment. At the landfill, the BOD tests could be prone to interferences from metals and other materials present. COD is therefore usually more representative of the leachate. This information could be used to determine the probability and severity of sealing and fouling occurring in the bed of an air stripper and GAC column. Sand filters or cartridge filters may be necessary to prevent sealing and fouling of the GAC columns. Also, if air stripping is used, vapor-phased GAC may be required to remove VOCs from the air stripper emissions.

For onsite remedial actions, the substantive requirements of the ARARs, but not the administrative requirements, must be met. Effluent from an onsite treatment system could be discharged to the Polk River; an NPDES permit could be required for this disposal method and appropriate ARARs (such as MCLs or water quality criteria) would be met.

As an interim action, or to supplement a groundwater extraction and treatment system, an alternate water supply could be provided to affected or potentially affected residents to limit exposure to contaminated groundwater. The water authority could provide the alternate water supply by extending the existing distribution system or installing a new deep well. Alternatively, bottled water could be used for temporary drinking and cooking. A comprehensive well inventory and subsequent sampling of nearby residential wells is needed to conduct a risk assessment to determine whether providing an alternate water supply is warranted.

4.4.4 Landfill Gas

The potential alternatives for this medium includes collection and possible treatment of landfill gas. This alternative involves intercepting the methane gas using passive vents, which typically consist of free venting structures; active vents if air emissions are

locally controlled; or collection of the gas by onsite extraction wells for treatment. Passive vent systems require that a highly permeable material be placed in the path of gas flow to intercept the landfill gas and discharge it to the air. An active vent system is used to control the venting of gases into the atmosphere when the constituents of the gas are of concern from an air quality standpoint. After collection, if necessary, landfill gas can then be incinerated using enclosed ground flares. Enclosed ground-flare systems consist of a refractory-lined flame enclosure (or stack) with a burner assembly at its base. Because of the rural nature of the example site, a passive venting system without treatment may be acceptable.

Information needed to determine the need for gas collection and treatment would be collected by placement of monitoring gas probes within the landfill as well as along the landfill perimeter and analyzed for methane, TCE, and vinyl chloride. The potential for pressure build-up below a landfill cap and potential for damage to a vegetative cover will be evaluated based on the quality and quantity of landfill gas estimated to be generated at the site.

4.4.5 Surface Water and Sediments

Contaminated sediments in the nearby unnamed tributary to the Polk River may require remediation. The most practicable alternatives for remediating contaminated sediments include excavation and consolidation under the landfill cap or leaving sediments in place and relying on natural attenuation. Sediment removal can be accomplished with conventional dredging or excavation equipment operated from shore.

The advantage of relying on natural attenuation to remediate sediments is that dredging activities can often cause secondary migration of contaminants which can potentially have significant environmental impacts. If dredging is done, these impacts should be minimized by dewatering during excavation activities.

Section 5

REMEDIAL INVESTIGATION AND FEASIBILITY STUDY OBJECTIVES

The overall goals of the RI/FS are to:

- Complete a field program for collecting data to quantify the extent and magnitude of contamination in the groundwater, subsurface soils, surface water/sediments, and landfill gas
- Determine if unacceptable risk exists to human health and the environment
- Develop and evaluate remedial action alternatives if unacceptable risks are identified

Table 5-1 shows the objectives of the Phase I RI for the Example Landfill site. After evaluation of the Phase I data, it may be necessary to conduct a Phase II. A Phase II would be conducted if the objectives of the Phase I RI are not accomplished. For example, if the Phase I RI groundwater sampling results indicate a contaminant plume but not enough data was collected to determine the extent of the plume, then further investigations will be warranted.

The objectives and actions listed in Table 5-1 only apply to the example site. These may vary for actual sites where the contaminated media and site conditions differ from the example site.

**Table 5-1
PHASE I REMEDIAL INVESTIGATION OBJECTIVES FOR
THE EXAMPLE SITE**

Activity	Phase I Objectives (Activities Generally Performed After Work Plan is Approved)	
	Objectives	Action
Site Mapping/Dynamics	Map site and determine topography; determine site boundaries, drainage patterns, and other geophysical features.	Use photogrammetric methods from aerial photography; conduct fly-over, if necessary.
Geophysical Investigation	Investigate probable presence of buried ferromagnetic materials (drums) in southern portion of the landfill.	Conduct magnetometer and/or ground penetrating radar survey.
Geotechnical Investigation	<p>Evaluate the physical properties governing transport of contaminants through identified pathways.</p> <p>Collect data on soil characteristics to determine if onsite soil can be used as fill material and to determine placement of a potential cap.</p> <p>Evaluate existing cap to determine physical properties.</p> <p>Measure current landfill settlement rate.</p>	<p>Collect data on permeability, porosity, hydraulic head, percent organic carbon, etc.</p> <p>Measure soil characteristics such as plasticity index, moisture content, porosity, and permeability.</p> <p>1) Collect data on permeability, porosity, and measure thickness. 2) Determine Atterberg limits. 3) Determine extent of vegetation cover, any vegetative stress, and erosion.</p> <p>Monitor landfill benchmarks.</p>
Hydrogeologic Investigation	<p>Determine selection of screen settings in both the shallow and deep wells.</p> <p>Identify and characterize hydrogeologic units.</p> <p>Determine direction of groundwater flow and estimate gradients.</p>	<p>Obtain soil classification or geologic data.</p> <p>1) Place monitoring wells at points around the landfill to better define the aquifers and confining layers. 2) Perform down-hole geophysical survey.</p> <p>1) Install monitoring wells and take water level measurements from new and existing wells. 2) Investigate yield of private and public wells.</p>
	Determine rate of groundwater flow and evaluate the feasibility of groundwater extraction.	Install monitoring wells and perform hydraulic conductivity tests on new and existing wells; check water levels at a maximum of once a month during the RI.
Meteorological Investigation	Determine prevailing wind direction and air speed to evaluate remedial alternatives.	Collect and analyze wind speed and direction data.

**Table 5-1
PHASE I REMEDIAL INVESTIGATION OBJECTIVES FOR
THE EXAMPLE SITE**

Activity	Phase I Objectives (Activities Generally Performed After Work Plan is Approved)	
	Objectives	Action
Chemical Investigation Groundwater	<p>Identify extent and type of groundwater contamination to perform an assessment of human health and environmental risks to determine if remedial action is necessary.</p> <p>Identify upgradient water quality for each geologic unit.</p> <p>Determine source of groundwater contamination.</p> <p>Determine whether seasonal fluctuations occur in contaminant concentrations in the groundwater and in hydraulic characteristics.</p> <p>Evaluate feasibility of groundwater treatment systems.</p>	<p>Install monitoring wells in aquifers of concern; design monitoring well network to determine the extent of the plume (wells should also be located downgradient in “clean” area to confirm that the end of the plume is located); collect and analyze samples.</p> <p>Install upgradient monitoring wells in aquifers of concern and collect and analyze samples.</p> <p>Collect and analyze groundwater samples and compare results to the landfill waste characteristics and background levels.</p> <p>Sample and analyze groundwater with a minimum of two rounds of sampling from the same location(s).</p> <p>Obtain COD, BOD, and other conventional water quality data.</p>
Leachate	<p>Identify extent and type of leachate seeps to evaluate feasibility of groundwater treatment system.</p> <p>Estimate amount of leachate production from landfill.</p>	<p>Collect and analyze leachate and seep data.</p> <p>Install leachate wells around land-fill and measure leachate head.</p> <p>Perform water balance calculation on landfill.</p>
Surface Water and Sediment	<p>Determine viability of treatment technologies</p> <p>Determine effect of groundwater on surface water.</p> <p>Compare stream and groundwater levels during several periods during the RI.</p>	<p>Collect field measurements on DO and temperature.</p> <p>Collect and compare up- and downgradient surface water and sediment samples to downgradient groundwater samples.</p> <p>Install staff gauges onsite, survey gauges, measure surface water levels and groundwater levels concurrently.</p>

**Table 5-1
PHASE I REMEDIAL INVESTIGATION OBJECTIVES FOR
THE EXAMPLE SITE**

Activity	Phase I Objectives (Activities Generally Performed After Work Plan is Approved)	
	Objectives	Action
Surface Water and Sediment (Continued)	Determine background concentration of surface water and sediment.	Collect and analyze upstream water and sediment samples; include toxicity testing.
Surface Water and Sediment	Determine surface runoff impact on surface water quality; determine the type and extent of contamination in nearby surface waters and sediments.	1) Collect and analyze samples from nearest leachate seeps and compare to stream water quality. 2) Collect and analyze surface water and sediment samples at increasing distances away from the landfill and compare results to landfill waste and background levels.
Landfill Gas/Air	Identify areas within the landfill containing high concentrations of explosive or toxic landfill gas to perform an assessment of human health risks due to air toxics and explosive hazards, to evaluate the feasibility of gas collection and treatment, and to evaluate other remedial actions. Estimate concentrations of selected VOCs being emitted to the atmosphere.	Obtain flow-related data from newly installed gas vents, estimate emission rates, and perform air modeling. Collect and analyze landfill gas samples from onsite and perimeter sampling points. Collect and analyze ambient air samples.
Landfill Gas/Groundwater	Identify areas within the landfill containing high concentrations of explosives or toxic landfill gas to determine if VOCs act or may act as a source of groundwater contamination	Obtain flow-related data from newly installed gas vents, estimate emission rates, and perform air modeling.
Hot Spots (Soil)	Investigate areal extent, depth, and concentration of contaminants at hot spots in the landfill's soil.	Collect and analyze perimeter samples with more extensive sampling around known hot spot area.
Environmental Evaluation	Determine impact of landfill on nearby stream. Describe aquatic and terrestrial community in vicinity of site and aquatic community downstream of site Determine impact of remedial action on stream.	Collect and analyze surface water and sediment from nearby stream. Observe aquatic or terrestrial organisms in the vicinity of the site. Collect biota samples from stream adjacent to site.

Section 6

DATA QUALITY OBJECTIVES

The data to be collected during the RI will be used for site characterization, risk assessment, and remedial action alternative evaluation. The objectives of the RI and the necessary actions to accomplish the objectives are shown in Table 5-1. The number and types of samples of soil, groundwater, leachate, sediments, surface water, and landfill gas to be collected for a sufficient representation of the conditions at the site; the chemicals of concern for which the samples are to be analyzed; and the precision, accuracy, representativeness, completeness, and comparability (PARCC) parameters to be used are summarized in Tables 6-1 through 6-3.

In order to achieve the established DQOs, a combination of laboratory services will be used for a more efficient use of time and money. All five levels of data quality will be used during the RI as described below:

- Level I--Field screening. This level is characterized by the use of portable instruments that can provide real-time data to assist in the optimization of sampling point locations and for health and safety support. Data can be generated regarding the presence or absence of certain contaminants (especially volatiles) at sampling locations. An HNu will be used for Level I analysis for soil samples and to monitor concentration of VOCs in air for health and safety considerations during drilling. Additionally an explosimeter will be used during drilling and soil probe installation; a radiation meter will be used initially to determine if harmful levels of radioactivity exist at the site.
- Level II--Field analysis. This level is characterized by the use of portable analytical instruments that can be used

onsite or in mobile laboratories stationed near a site (close-support labs). Depending on the types of contaminants, sample matrix, and personnel skills, qualitative and quantitative data can be obtained. An onsite mobile laboratory will be used during well installation to provide analytical results that will be used to re-evaluate the proposed monitoring well network. Groundwater samples will be analyzed for selected VOCs and inorganic ions (chloride and sulfate) to aid in determining the extent of the groundwater plume. Soil gas samples will also be analyzed for VOCs to determine the extent of the solvent disposal area.

- Level III--Laboratory analysis using methods other than the CLP Routine Analytical Services (RAS). This level is used primarily in support of engineering studies using standard EPA approved procedures. Some procedures may be equivalent to CLP RAS, without the CLP requirements for documentation. Analysis will include COD, BOD, TOC, and TSS in groundwater and leachate samples.
- Level IV--CLP RAS. This level is characterized by rigorous QA/QC protocols and documentation and provides qualitative and quantitative analytical data. Some regions have obtained similar support via their own regional laboratories, university laboratories, or other commercial laboratories. This level will be used for confirmatory sampling of groundwater, hot spots, surface water, and sediments. Analyses performed will include TCL organics and TAL metals.

- Level V--Nonstandard methods. These are analyses that may require method modification and/or development. CLP Special Analytical Services (SAS) are considered Level V. This level will be used for vinyl chloride in groundwater and leachate where lower detection limits are warranted.
- Other--Geotechnical testing to determine soil characteristics and other data, such as pH and conductivity, will be conducted to aid in the engineering design of alternatives. Geotechnical analysis will be done by a commercial laboratory. Conductivity and pH will be analyzed in the field.

**Table 6-1
DATA QUALITY OBJECTIVES SUMMARY FOR GROUNDWATER/LEACHATE
OF THE EXAMPLE LANDFILL SITE**

Data Quality Objective Elements	Site Characterization	Risk Assessment	Engineering Design of Alternative
Objective	<ul style="list-style-type: none"> Identify extent and type of contamination Determine if contaminants are present in residential wells 	<ul style="list-style-type: none"> Assess risks due to ingestion 	<ul style="list-style-type: none"> Evaluate feasibility of groundwater treatment system
Data Quality Factors			
Prioritized Data Use(s)	Site characterization	Risk assessment	Engineering design of alternative
Contaminants of Concern	TCE, vinyl chloride, lead, arsenic, chloride, chromium	TCE, vinyl chloride, lead, arsenic, chromium	COD, BOD, pH, conductivity
Level of Concern (ARARs)^a			
TCE	5 ppb	5 ppb	N/A
Vinyl chloride	2 ppb	2 ppb	N/A
Lead	50 ppb	50 ppb	N/A
Arsenic	50 ppb	50 ppb	N/A
Chloride	N/A	N/A	N/A
Sulfate	N/A	N/A	N/A
Chromium	50 ppb	50 ppb	N/A
Reporting Limit^b			
TCE	5 ppb	5 ppb	N/A
Vinyl chloride	10 ppb	2 ppb	N/A
Lead	5 ppb	5 ppb	N/A
Arsenic	10 ppb	10 ppb	N/A
Chloride	50 ppb	N/A	N/A
Sulfate	50 ppb	N/A	N/A
Chromium	10 ppb	10 ppb	N/A
Appropriate Analytical Levels	I, II, IV	IV and V	III and Other
Critical Samples	Residential wells	Residential wells	Monitoring wells
Data Quality Needs			
Sampling/Analysis Procedures			
<ul style="list-style-type: none"> Sample Collection^c Sample Analysis 			
Level I--Field Screening ^d	Use of HNu		
N/A--Not applicable			
<p>^a These are federal MCLs from the SDWA. While federal ARARs are stated for this example, state ARARs may preclude the federal ARARs.</p> <p>^b The listed values are the Contract Required Quantitation Limits (CRQLs) taken from the CLP SOWs (Level IV). Since reporting limits in some cases are at or above levels of concern, special analytical services (SAS) reporting limits (Level V) may be required to achieve lower detection limits (e.g., vinyl chloride). This CRQL is matrix dependent and may not be achievable in every sample,</p> <p>^c Sample collection procedures are outlined in the <i>A Compendium of Superfund Field Operations Methods</i>, August 1987.</p> <p>^d Level I analytical methods are not compound specific, only quantitative for total organics.</p>			

**Table 6-1
DATA QUALITY OBJECTIVES SUMMARY FOR GROUNDWATER/LEACHATE
OF THE EXAMPLE LANDFILL SITE**

Data Quality Objective Elements	Site Characterization	Risk Assessment	Engineering Design of Alternative
Level II--Field Analysis ^e TCE Vinyl chloride Lead Arsenic Chloride Sulfate Chromium ^f	GC/ECD/PID GC/ECD/PID Atomic Absorption Atomic Absorption Ion Chromatograph Ion Chromaograph Atomic Absorption		
Level III--Non-CLP Lab Methods ^g COD BOD TSS TOC			EPA 405.1 EPA 410.1 EPA 209
Level IV--CLP RAS TCE Lead Arsenic Chromium	CLP Organic SOW CLP Inorganic SOW CLP Inorganic SOW CLP Inorganic SOW	CLP Organic SOW CLP Inorganic SOW CLP Inorganic SOW CLP Inorganic SOW	N/A N/A N/A N/A
Level V--CLP SAS ^h Vinyl chloride		EPA 601	
Other pH Specific Conductance			pH meter Conductivity meter
PARCC Parameters			
<ul style="list-style-type: none"> • Precisionⁱ <ul style="list-style-type: none"> - TCE - Vinyl chloride - Lead - Arsenic - Chromium 	<ul style="list-style-type: none"> <14 +25% ±20% ±20% ±20% 		
<ul style="list-style-type: none"> • Accuracyⁱ <ul style="list-style-type: none"> - TCE - Vinyl chloride - PCB - Lead - Arsenic - Chromium 	<ul style="list-style-type: none"> 71-120% 75-125% N/A 75-125% 75-125% 75-125% 		
N/A--Not applicable ^e Method used by the onsite mobile laboratory. ^f Only total chromium will be detected. ^g Level II analysis is only for parameters not on the CLP TLC and TAL lists and for cases where QC requirements are less stringent than that of the CLP methods. Level III analysis is not applicable for the selected contaminants of concern listed except for COD and BOD in groundwater and TCE and vinyl chloride in landfill gas. ^h Level V-CLP SAS methods may include modified versions of CLP RAS methods to achieve lower detection limits, to provide project-specific QC, to analyze for non-CLP parameters or to use non-CLP methods but still provide the levels and types of QA/QC and deliverables prevented by CLP RAS. ⁱ The listed values precision and accuracy in analysis of water samples are based on CLP RAS SOW requirements and do not necessarily reflect actual method performance.			

**Table 6-1
DATA QUALITY OBJECTIVES SUMMARY FOR GROUNDWATER/LEACHATE
OF THE EXAMPLE LANDFILL SITE**

Data Quality Objective Elements	Site Characterization	Risk Assessment	Engineering Design of Alternative
<ul style="list-style-type: none"> • Representativeness^j • Completeness^k • Comparability^l 			

^j Qualitative parameter, which considers the project as a whole. No numerical criteria can be set.

^k Can be expressed as a quantitative assessment of the percentage of valid data received. Also includes a qualitative parameter and must be assessed after all data are reviewed.

^l A qualitative parameter that can be maximized through the use of standard sampling, analysis, and data review techniques.

**Table 6-2
DATA QUALITY OBJECTIVES SUMMARY FOR HOT SPOTS, FILL, AND CAP INVESTIGATION
OF THE EXAMPLE LANDFILL SITE**

Data Quality Objective Elements	Hot-Spot Areas	Fill	Cap Investigation
Objective	<ul style="list-style-type: none"> Identify highly contaminated areas that may be present onsite Assess risk due to direct contact 	<ul style="list-style-type: none"> Determine if fill can be used for capping 	<ul style="list-style-type: none"> Determine existing cap characteristics
Data Quality Factors			
Prioritized Data Use(s)	Site characterization, risk assessment, and engineering design of alternatives	Engineering design of alternative	Engineering design of alternative
Contaminants of Concern	TCE, PCB, lead, arsenic, chromium, treatability parameters	Geotechnical parameters	Permeability, porosity, depth
Level of Concern (ARARs)^a			
TCE	636 ppb		
Vinyl chloride	0.3 ppb		
PCB	0.091 ppb		
Lead	105 ppb		
Arsenic	3 ppb		
Chromium	(III) 75,000, (VI) 375 ppb		
Reporting Limit ^b			
TCE	5 ppb		
Vinyl chloride	10 ppb		
PCB	80 ppb		
Lead	500 ppb		
Arsenic	1,000 ppb		
Chromium	1,000 ppb		
Appropriate Analytical Levels	Site characterization: II, III, IV Risk assessment: IV and V	Engineering design of alternative, III	Engineering design of alternative, Other
Critical Samples	Clean samples at outer boundary of contaminated area	Collect samples from perimeter of waste area to determine areal extent of waste	
Data Quality Needs			
Sample/Analysis Procedures			
<ul style="list-style-type: none"> Sample Collection^c Sample Analysis 			
Level I–Field Screening ^d			

^a While federal ARARs are stated for this example, state ARARs may preclude the federal ARARs. Numbers listed should be updated to incorporate current guidance. For carcinogens, numbers are based on the 10⁻⁶ cancer risk. For noncarcinogens, numbers are based on the reference dose. All numbers are calculated for a 17-kg child ingesting 0.2 gms of soil per day.

^b The listed values are the Contract Required Quantitation Limits (CRQLs) taken from the CLP SOWs (Level IV). The CRQL is matrix dependent and may not be achievable in every sample. The actual reporting limit will also be affected by moisture content for soil and sediment samples. Some samples are analyzed as received but reported on a dry-weight basis. Since reporting limits in some case are at or above levels of concern, SAS reporting limit (Level V) may be required to achieve lower detection limits (e.g., vinyl chloride).

^c Sample collection procedures are outlined in the *A Compendium of Superfund Field Operations Methods*, August 1987.

^d Level I analytical methods are not compound specific, only quantitative for total organics. Not used for soil investigation.

**Table 6-2
DATA QUALITY OBJECTIVES SUMMARY FOR HOT SPOTS, FILL, AND CAP INVESTIGATION
OF THE EXAMPLE LANDFILL SITE**

Data Quality Objective Elements	Hot-Spot Areas	Fill	Cap Investigation
Level II–Field Analysis ^e TCE Vinyl chloride Lead Arsenic Chromium ^f	GC/ECD/PID GC/ECD/PID X-ray Fluorescence X-ray Fluorescence X-ray Fluorescence		
Level III–Non-CLP Lab Methods ^g			
Level IV–CLP RAS TCE Vinyl chloride PCB Lead Arsenic Chromium	CLP Organic SOW CLP Organic SOW CLP Organic SOW CLP Inorganic SOW CLP Inorganic SOW CLP Inorganic SOW		
Level V–CLP SAS ^h			
Other Moisture Content Permeability In Situ Density ⁱ Atterberg Limits Grain Size Analysis BTU content TCLP		ASTM 2216-80 SW 846, Method 9100 ASTM D4318 ASTM D422	N/A SW 846, Method 9100 N/A N/A N/A
PARCC Parameters			
• Precision ^j - TCE - Vinyl Chloride - PCB - Lead - Arsenic - Chromium	<20 ±25% ±25% ±20% ±20% ±20%		
• Accuracy ^j - TCE - Vinyl chloride - PCB - Lead - Arsenic - Chromium	62-137% 75-125% 75-125% 75-125% 75-125% 75-125%		
^e Level II methods used by the onsite mobile laboratory and soil gas analysis. ^f Only total chromium will be detected. ^g Level II analysis is only for parameters not on the CLP TLC and TAL lists and for cases where QC requirements are less stringent than those of the CLP methods. Level III will not be used for these media. ^h Level V–CLP SAS methods may include modified versions of CLP RAS methods to achieve lower detection limits, to provide project-specific QC, to analyze for non-CLP parameters, or to use non-CLP methods, but they still provide the levels and types of QA/QC and deliverables prevented by CLP RAS. Level V will not be used for these media. ⁱ Method report in <i>Methods for Soil Analysis</i> , Section 13.2 ^j The listed values for precision and accuracy in analysis of soil, sediment, and water samples are based on CLP RAS SOW requirements and do not necessarily reflect actual method performance. Precision and accuracy performance for landfill gas samples are method dependent and should be determined on a project-specific basis.			

**Table 6-2
DATA QUALITY OBJECTIVES SUMMARY FOR HOT SPOTS, FILL, AND CAP INVESTIGATION
OF THE EXAMPLE LANDFILL SITE**

Data Quality Objective Elements	Hot-Spot Areas	Fill	Cap Investigation
<ul style="list-style-type: none"> • Representativeness^k • Completeness^l • Comparability^m 			

^k Qualitative parameter, which considers the project as a whole. No numerical criteria can be set.

^l Can be expressed as a quantitative assessment of the percentage of valid data received. Also includes a qualitative parameter and must be assessed after all data are reviewed.

^m A qualitative parameter that can be maximized through the use of standard sampling, analysis, and data review techniques.

**Table 6-3
DATA QUALITY OBJECTIVES SUMMARY FOR SURFACE WATER, SEDIMENT
AND LANDFILL GAS OF THE EXAMPLE LANDFILL SITE**

Data Quality Objective Elements	Surface Water	Sediment	Landfill Gas
Objective	Evaluate impact of surface water runoff from the site to the unnamed tributary	Evaluate impact of surface water runoff from the site to the sediment of the unnamed tributary	Identify areas within the landfill containing high concentrations of selected VOCs. Identify landfill gas contaminant concentration at perimeter of site to evaluate impact from offsite migration.
Data Quality Factors			
Prioritized Data Use(s)	Site characterization, risk assessment	Site characterization	Site characterization
Contaminants of Concern	TCE, PCB, lead, arsenic, chromium	TCE, PCB, lead, arsenic, chromium	Methane, TCE, vinyl chloride
Level of Concern (ARARs)^a			
TCE	2.7 ppb	636 ppb	N/A
Vinyl chloride	2.0 ppb	0.3 ppb	N/A
PCB	0.000079 ppb	0.091 ppb	N/A
Lead	50 ppb	105 ppb	N/A
Arsenic	0.0002 ppb	0.35 ppb	N/A
Chromium	50 ppb	(III) 75,000, (IV) 375 ppb	N/A
Methane	N/A	N/A	No federal ARAR ^b
Reporting Limit ^c			
TCE ^d	5 ppb	5 ppb	
Vinyl chloride ^d	10 ppb	10 ppb	
PCB	0.5 ppb	80 ppb	N/A
Lead	5 ppb	500 ppb	N/A
Arsenic	10 ppb	1,000 ppb	N/A
Chromium	10 ppb	1,000 ppb	N/A
Methane ^d	N/A	N/A	
Appropriate Analytical Levels	Site characterization and risk assessment: IV and V	Site characterization: IV	Site characterization: III
Critical Samples	Samples from the groundwater and leachate seeps	Samples from the groundwater and leachate seeps	Samples from areas of the landfill where it is suspected that methane gas is produced
<p>^a Surface water—These are based on the <i>Federal Ambient Water Quality Criteria</i>, a nonenforceable guidance document under the CWA and are either based on toxicity protection (lead, chromium) or the 10 cancer risk level. The selected criteria are the chronic criteria for protection of Aquatic life. The level of concern for chromium is for both the total and hexavalent species. While federal ARARs are stated for this example, state ARARs may preclude federal ARARs if they are more stringent.</p> <p>^b Several states have air toxics emissions regulations. Guidance on air ARARs can be found in the National Air Toxics Information Clearinghouse Database Report on state, local, and EPA air toxics.</p> <p>^c The listed values are the Contract Required Quantitation Limits (CRQLs) taken from the CLP SOWs (Level IV). This CRQL is matrix dependent and may not be achievable in every sample. The actual reporting limit will also be affected by sample moisture content for sediment samples. Some samples are analyzed as received but reported on a dry-weight basis. Since reporting limits in some cases are at or above levels of concern, SAS reporting limits (Level V) may be required to achieve lower detection limits (e.g., vinyl chloride).</p> <p>^d The reporting limit for TCE, vinyl chloride and methane is dependent upon the volume of gas sampled and should be established for each sampling event.</p>			

**Table 6-3
DATA QUALITY OBJECTIVES SUMMARY FOR SURFACE WATER, SEDIMENT
AND LANDFILL GAS OF THE EXAMPLE LANDFILL SITE**

Data Quality Objective Elements	Surface Water	Sediment	Landfill Gas
Data Quality Needs			
Sample/Analysis Procedures • Sample Collection ^e • Sample Analysis			
Level I–Field Screening ^f			
Level II–Field Analysis ^g			
Level III–Non-CLP Lab Methods ^h			
Methane	N/A	N/A	T014
TCE	N/A	N/A	T014
Vinyl chloride	N/A	N/A	T014
TSS	EPA 209	N/A	N/A
Alkalinity		N/A	N/A
Hardness		N/A	N/A
TOC	N/A		N/A
Grain Size Analysis	N/A	ASTM D422	N/A
% Moisture	N/A		N/A
% Solids	N/A		N/A
Level IV–CLP RAS ⁱ			
TCE	CLP Organic SOW	CLP Organic SOW	
Vinyl Chloride	CLP Organic SOW	CLP Organic SOW	
PCB	CLP Organic SOW	CLP Organic SOW	
Lead	CLP Inorganic SOW	CLP Inorganic SOW	
Arsenic	CLP Inorganic SOW	CLP Inorganic SOW	
Chromium	CLP Inorganic SOW	CLP Inorganic SOW	
Level V– CLP SAS ^j			
Toxicity Tests ^k			
Other			
Eh	Eh Meter	EPA 9045	N/A
pH	pH Meter	pH Meter	N/A
Specific Conductance	Conductivity Meter	EPA 126.1	N/A

N/A–Not applicable.

^e Sample collection procedures are outlined in the *A Compendium of Superfund Field Operations methods*, August 1987.

^f Level I analytical methods are not compound specific, only quantitative for total organics. Level I will not be used for the surface water sediment, and landfill gas media.

^g Level II will not be used for analysis of the surface water, sediment, or landfill gas samples.

^h Level III analysis is only for parameters not on the CLP TLC and TAL lists and for cases where QC requirements are less stringent than that of the CLP methods. Level III analysis is not applicable for the selected contaminants of concern listed except for TCE and VC in landfill gas.

ⁱ CLP RAS methods are not currently available for landfill gas. These samples will always be analyzed by Level III methods.

^j Level V-CLP SAS methods may include modified versions of CLP RAS methods to achieve lower detection limits, to provide project-specific QC, to analyze for non-CLP parameters, or to use non-CLP methods but still provide the levels and types of QA/QC and deliverables prevented by CLP RAS. Some standard SAS methods are reported for landfill gas.

^k Acute and chronic bioassays are done for surface water with invertebrate, vertebrate and plant species. For sediments, EP toxicity test are done.

**Table 6-3
DATA QUALITY OBJECTIVES SUMMARY FOR SURFACE WATER, SEDIMENT
AND LANDFILL GAS OF THE EXAMPLE LANDFILL SITE**

Data Quality Objective Elements	Surface Water	Sediment	Landfill Gas
PARCC Parameters			
<ul style="list-style-type: none"> • Precision^l - TCE - Vinyl Chloride - PCB - Lead - Arsenic - Chromium - Methane 	<p><14</p> <p>±25%</p> <p>±25%</p> <p>±20%</p> <p>±20%</p> <p>±20%</p> <p>N/A</p>	<p><20</p> <p>±25%</p> <p>±25%</p> <p>±20%</p> <p>±20%</p> <p>±20%</p> <p>N/A</p>	
<ul style="list-style-type: none"> • Accuracy^m TCE Vinyl chloride PCB Lead Arsenic Chromium Methane 	<p>75-125%</p> <p>N/A</p> <p>N/A</p> <p>N/A</p> <p>N/A</p> <p>N/A</p> <p>N/A</p>	<p>62-137%</p> <p>75-125%</p> <p>75-125%</p> <p>75-125%</p> <p>75-125%</p> <p>75-125%</p> <p>N/A</p>	
<ul style="list-style-type: none"> • Representativenessⁿ • Completeness^o • Comparability^o 			
<p>N/A–Not applicable.</p> <p>^l The listed values for precision and accuracy in analysis of water samples are based on CLP RAS SOW requirements and do not necessarily reflect actual method performance. Precision and accuracy performance for landfill gas samples are method dependent.</p> <p>^m Qualitative parameter, which considers the project as a whole. No numerical criteria can be set.</p> <p>ⁿ Can be expressed as a quantitative assessment of the percentage of valid data received. Also includes a qualitative parameter and must be assessed after all data re reviewed.</p> <p>^o A qualitative parameter that can be maximized through the use of standard sampling, analysis, and data review techniques.</p>			

Section 7 RI/FS TASKS

The field investigation is conducted to provide data that can be used to determine the type and extent of contamination at the site and to identify if the site poses risks to human health and the environment. The RI/FS tasks described in this work plan have been developed to meet these objectives. This section of the work plan follows the standard format outlined in the *RI/FS Guidance* (U.S. EPA, 1988a). Several of these activities were conducted before developing this work plan. These activities include the evaluation of existing data and the performance of limited field investigations. The results of both of these activities are reported in Section 2 and 3, respectively, of this appendix.

7.1 RI/FS Tasks

The following tasks have been identified for the RI/FS:

- Task 1--Project Planning
- Task 2--Community Relations Activities
- Task 3--Field Investigations
 - ! Subtask 3A--Fieldwork Support
 - ! Subtask 3B--Surveying and Mapping
 - ! Subtask 3C--Geophysical Investigation
 - ! Subtask 3D--Soil Gas Survey
 - ! Subtask 3E--Cap Investigation
 - ! Subtask 3F--Source Testing, Test Pits, Soil Samples (perimeter)
 - ! Subtask 3G--Hydrogeologic Investigation

- ! Subtask 3H--Groundwater Sampling
- ! Subtask 3I--Residential Well Sampling
- ! Subtask 3J--Surface Water and Sediment Sampling
- ! Subtask 3K--Landfill Gas Emissions Sampling
- ! Subtask 3L--RI-Derived Waste Disposal

- Task 4--Sample Analysis/Data Validation
- Task 5--Data Evaluation
- Task 6--Risk Assessment
- Task 7--Remedial Investigation Report
- Task 8--Remedial Alternative Development
- Task 9--Alternatives Evaluation
- Task 10--Feasibility Study Report
- Task 11--Treatability Studies

7.1.1 Task 1--Project Planning

Included in this task are limited field investigation activities, existing data evaluation, development of the work plan; obtaining appropriate approvals for the work plan, budget, and schedule; preparation of the sampling and analysis plan (SAP), which consists of the Quality Assurance Project Plan (QAPP) and the Field Sampling Plan (FSP); preparation of the Site Safety Plan (SSP); project management and agency coordination; obtaining easements and permits, if necessary; and meetings among EPA, the State, and the contractor.

Development of the RI/FS work plan includes formulation of DQOs, identification of the necessary RI/FS tasks, and preparation of budgets and schedules for implementing the proposed RI/FS tasks. Results of the existing data evaluation are presented in Section 2 of this document and results of the limited field investigation activities reported in Section 3 were utilized to develop the scope of RI activities. Potential ARARs and remedial action alternatives for the example site are discussed in Section 4 of this document. This information was also utilized to develop the RI scope.

A SAP will be prepared in conjunction with the work plan that will include a QAPP, FSP, and an SSP for the proposed field activities. The QAPP will specify the analytical procedures and the methods for analytical choices and data reduction, validation, and reporting. The FSP will indicate proposed sampling locations, collection procedures, and the equipment necessary for sampling and testing. The procedures outlined in the *Compendium of Superfund Field Operations Methods* (U.S. EPA, 1987c) and the *Users Guide to the Contract Laboratory Program* (U.S. EPA, 1988b) will be used to develop the FSP. Sample custody procedures, including those related to chain-of custody, also will be delineated in the FSP and will conform to the procedures detailed in the National Enforcement Investigation Center's *Policies and Procedures for Sample Control*. Preparation of the SSP will also be based on historical information, OSHA regulations, and corporate health and safety policies.

At critical junctures of the project, it will also be necessary to conduct meetings between EPA, the contractor, and other appropriate parties to discuss project deliverables and the schedule and to evaluate the need for additional studies. Table 7-1 summarizes the subject, frequency, participants, and locations of proposed meetings for all tasks.

7.1.2 Task 2--Community Relations Activities

A community relations plan will be prepared addressing activities that EPA will conduct with residents and government officials involved with

the site. The plan will contain the following sections:

- Site description
- History of the site
- Community issues
- Objectives of the community relations plan
- Community relations activities
- Schedule of community relations activities through ROD

Information presented in the plan will be developed from previous work conducted at the site and interviews conducted with federal, state, and local officials and residents, as appropriate.

Public meeting contractor support can be provided by issuing Agency-approved public notices, supplying court recorders, and preparation of visual aids. In addition, project updates will be developed to provide information regarding project status. An update will be distributed at the beginning of the field investigation, and a second once the field investigation is complete. A proposed plan summarizing the alternative selection process and the preferred remedial action alternative will be prepared for public comments. A final fact sheet will be prepared after the ROD is signed to explain the remedial action alternative selected for the site.

7.1.3 Task 3--Field Investigation

All efforts to prepare for onsite work, with the exclusion of sample analysis, are included in this task.

7.1.3.1 Subtask 3A--Fieldwork Support

Fieldwork support includes those activities that are necessary before the field activities can be implemented. The following sections describe these activities and include those associated with subcontractor and equipment procurement and site setup.

**Table 7-1
PROJECT MEETING SUMMARY FOR THE RI/FS AT THE EXAMPLE SITE**

Task Budgeted Under	Subject of Meeting	No. of Meetings	Anticipated Point in Schedule	Meeting Participants*			Anticipated Meeting Location
				Contractor	EPA Region	Other	
1	Project kickoff meeting	2	Before initiation of project tasks	Project manager (PM), task leaders	Remedial project manager (RPM), technical advisors, project officer	State representative, Natural Resource Trustees, if appropriate	EPA office and the site
1	Project progress meetings	6	Quarterly for duration of RI/FS	PM, task leaders	RPM and technical advisors (as appropriate)	State representative, Natural Resource Trustees, if appropriate	3 in EPA office 3 in contractor's office
1	Public meetings	2	Before RI/FS initiation and following EPA issuance of FS report, and public review period and comment period	PM	RPM, technical advisors	PRP and State representatives	Site
2	Community relations organizational meeting	3	Before RI/FS initiation, before issuing proposed plan, and before issuing final fact sheet	PM, community relations specialist	RPM, risk assessment specialist	State representative	EPA office
3	Discuss field activities	2	During field activities	PM, senior hydrogeologist	RPM hydrogeologist	State representative	EPA office or at site, if necessary
7	RI Outline Report	1	After RI field data is available				
7	Draft RI Report	1	After EPA review of draft RI report	PM, senior hydrogeologist, risk assessment specialist	RPM, technical specialists	State representative, Natural Resource Trustees, if appropriate	EPA office
8	RA screening	1	During RA screening	PM, process engineer	RPM, technical specialists	State representative	Remedial contractor's office
10	FS Outline	1	After RA screening				
10	Draft FS report	1	After EPA review of draft FS report	PM, process engineer	RPM, technical specialist	State representative, Natural Resource Trustees, if appropriate	EPA office

Note:

* Meeting participants may vary depending on the EPA Region.

Subcontractor Procurement. Several of the investigative activities that will be conducted during the course of the RI will require services typically provided by contractors other than those scoping and performing the RI/FS. Services expected to be subcontracted are:

- Construction of decontamination pad
- Provision of trailer for onsite office and mobile laboratory and hookups of electricity and telephone
- Obtaining sample bottles
- Surveying and topographic mapping
- Drilling and installation of monitoring wells
- Geophysical studies
- Excavation of hot spot area test pits
- Fencing of investigation waste storage area
- Commercial laboratory for engineering design analysis (BOD, COD, etc.)
- Geotechnical laboratory analysis
- Removal of RI-derived waste, if necessary
- Treatability studies, as appropriate

Equipment Procurement and Site Setup. This element involves securing and shipping field equipment and health and safety equipment/materials onsite and setting up an onsite field office trailer and support area. A mobile trailer will be rented for use as an onsite office and for storing equipment and supplies. This trailer will also house the onsite mobile laboratory. The trailer will be equipped with air conditioning (fieldwork planned for the summer), telephone, water, and electricity. A decontamination pad will also be constructed.

7.1.3.2 Subtask 3B--Surveying and Mapping

A preliminary search for existing maps and aerial photographs from sources such as the Department of Transportation and the U.S. Geological Survey was made during the evaluation of existing data. An aerial topographic survey of the site and surrounding area will be conducted. This aerial survey will be field checked by a ground survey crew who will establish a localized baseline and benchmark for future sampling and to tie-in new well locations. Stream contours will also be established from water depths. The topographic site map covering the 60 acres of the site and immediate surrounding area will consist of contour lines on 1-foot intervals and use a scale of 1" = 75'. A topographic map with a contour interval of 2 feet and a scale of 1" = 100' will be developed for a much broader area of 145 acres and will include the surface-water drainage system. The locations of surface features such as power lines, fences, and sewers will also be located on the site map to aid in the geophysical investigations.

7.1.3.3 Subtask 3C--Geophysical Investigation

Surface geophysical surveys will be performed in the southeast section of the landfill. The purpose of these studies is to confirm suspected landfill areas that may contain buried hazardous waste drums, to aid in selecting test pit sites, and to delineate the extent of the fill. The need for the geophysical investigation was determined during the scoping activities where indications of a buried drum area were identified through review of existing aerial photographs and interviews with former employees. A magnetometer survey (total field and vertical gradient) will be used to meet these objectives. It should be noted, however, that landfills contain many products other than drums that are made of metal. Therefore, this type of investigation is used only when there is evidence to suggest large discrete areas of drum disposal. While the survey cannot specifically distinguish between drums and other metal objects, they can delineate areas of buried metal masses. Subsequent investigations such as the test pits will be used to further explore the specific nature of the buried metal and to investigate

subsurface soil conditions below areas of waste disposal.

Magnetometer Survey. A magnetometer survey will be conducted to determine the location, extent, and relative magnitude of the drum disposal area. Before the survey, a 100-foot by 40-foot grid will be laid out over the southeastern portion of the landfill, which encompasses the area of suspected drum disposal (Figure 7-1). A magnetometer base station will also be established to monitor diurnal changes in the magnetic field (for correction purposes). Once the grid and base station have been located, magnetometer readings will be collected at 20-foot centers using an Magnetometer/Gradiometer. Any other readings made from locations not marked by a grid flag will be located by positioning a marked tape or rope along the appropriate line.

The magnetometer survey will consist of total field measurements and vertical magnetic gradient measurements. Vertical gradient data are capable of higher resolution than the total field data and will minimize potential noise problems. The total field and gradient data will be collected simultaneously.

Upon completion of the magnetometer survey, data will be corrected for the effects of the diurnal changes in the local magnetic field. Once this has been done, a magnetic contour map will be prepared to interpret magnetic anomalies.

7.1.3.4 Subtask 3D--Soil Gas Survey

A soil gas survey will be conducted in conjunction with the magnetometer survey to locate the boundaries of the drum disposal area. The magnetometer survey may be inconclusive if the number of drums per unit area is low or if the drums are buried deeply. A soil gas survey will be concentrated in the southeast corner of the landfill. A soil gas survey, coupled with the mobile laboratory analysis of the soil gas for a few selected VOCs, may provide immediate information on the lateral extent of contamination of the soil (primarily in the liquid solvent disposal area) and possibly the groundwater. This survey may also minimize the number of geotechnical borings and monitoring wells that must be drilled or installed.

Soil gas ground probes will be used to save time and expense. Ground probes will be driven to the desired depth and a vacuum pump used to draw a sample from the probe. The soil gas samples will be collected in Tedlar bags.

Sample analyses will be furnished by an onsite mobile laboratory. The laboratory will use a gas chromatograph with a photoionization detector. Samples will be analyzed for 1,1-DCE, TCE, 1,1,1-TCA, and toluene.

Initially vertical profiles of organic gases present in the soil pore spaces will be measured and plotted at several locations. A sampling depth of at least 4 feet will also be selected, based on the measured vertical profiles. However, sampling probe depth within the landfill may be limited by the presence of buried drums and extreme care must be exercised. Once this constant sampling depth is established, soil gas samples will be collected across a grid. Samples will be collected on a 20-foot by 20-foot grid laid out over an area measuring 200 feet by 200 feet. Initially, samples will be collected nearest the suspected disposal location. Once the location is identified, sampling on a 10-foot by 10-foot grid will be done to more accurately identify the limits of the area. In the event that results from the initial vertical profiles do not provide data to sufficiently locate the solvent plume, the soil gas survey will be discontinued. A maximum of 80 soil gas samples will be taken in the initial effort. An additional maximum of 20 soil gas samples will be taken on a 100-foot by 100-foot grid to identify the extent of the groundwater contamination south of the disposal area. Depending on the location of the solvent disposal area, this survey may include additional areas within the landfill.

7.1.3.5 Subtask 3E--Cap Investigation

The cap covers the southern portion of the landfill as shown in Figure 2-1. Because the cap was engineered and may be used as a component of the final cover system, further investigation on its construction is warranted. The objectives of the cap investigations are to:

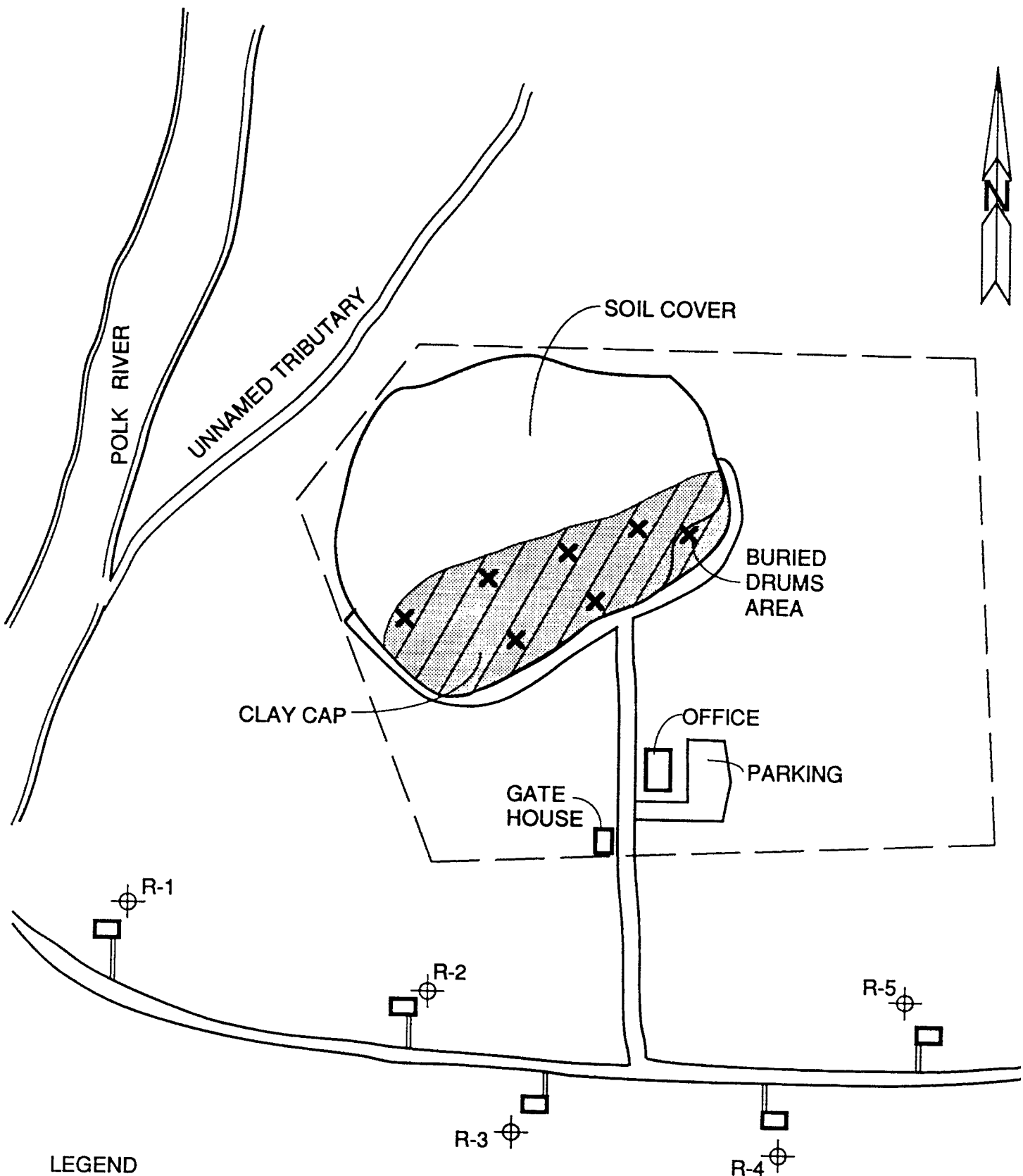

LEGEND

- ⊕ RESIDENTIAL WELLS
- ✕ TEST PIT LOCATIONS

**Figure 7-1
CAP INVESTIGATION
TEST PIT LOCATION
EXAMPLE SITE**

- Determine the permeability of the existing cap
- Evaluate the susceptibility to damage from freezing, drying, and erosion
- Determine thickness of existing cap

Permeability tests performed on undisturbed (Shelby tube) samples will be used to determine the effectiveness of the cap as it currently exists. Undisturbed and remolded sample permeability and density tests will be compared to explore the susceptibility of the cap soil to damage from freezing and drying. Characterization and permeability testing will also be used to support evaluation of remedial alternatives such as construction of a multilayer cap. These objectives can be achieved as explained in the following paragraphs.

A maximum of seven test pits (see Figure 7-1) will be dug at the site to show the constructed cross section of the cap. The visual extent of cracking, layering, root-penetration and vegetation success will be noted when the pits are dug. The test pits will be hand dug or dug with a narrow-bucket backhoe and are expected to be about 2 feet deep. A nuclear density gauge will be used to determine in situ density and moisture content at various locations across the site. The quantity and locations of the nuclear density tests will be determined in the field.

Samples from the test pits will be sent to a geotechnical laboratory for analysis if it is determined during the test pit program that the cap is a clay cap. A summary of the sampling and analysis program is presented in Table 7-2. The samples will be tested for moisture content and will be characterized by grain size analysis, and Atterberg limits. One moisture-density relation test will be performed using a soil sample taken from a representative test pit. A flexible-wall permeability test will be performed on a remolded sample, compacted to 95 percent maximum density at the optimum moisture content. This data will be used to determine the permeability of the existing cap and whether the cap has the geotechnical properties necessary to be used as a base if a new cap were

constructed over the existing material.

Shelby tube samples will be taken at each of the test pit locations. The Shelby tubes will be pushed using the backhoe bucket that is needed for the hydrogeologic investigation. If the characterization tests performed on the test pit samples indicate markedly different soil types, additional Shelby tube samples may be necessary. Shelby tube samples will be analyzed for in-situ density and moisture. Flexible-wall permeability tests will be performed on samples taken from the Shelby tubes.

Geotechnical laboratory tests will require monitoring of the procedures and equipment being used. Specifications for each test will be prepared and included as part of the drilling subcontract. The drilling subcontractor will be responsible for retaining a laboratory (with the remedial contractor's approval) who is capable of conforming to the specifications. A geotechnical engineer will visit the laboratory at least once to review the procedures and equipment being used.

Also additional permeability tests on different locally available soils or onsite soil-bentonite clay mixtures will be performed. This is necessary because it is expected that a cap will be needed for the currently uncapped northern section of the landfill. And because it may be necessary to upgrade the existing cap if it has a high permeability or is geotechnically unstable.

After the initial stage of geotechnical investigation and sampling is completed, the results will be evaluated to determine whether or not more fieldwork is needed. Results of the permeability tests will be reviewed along with compaction tests. To fully evaluate capping alternatives, it will be necessary to construct test patches of the proposed cover material over the landfill to determine the feasibility of achieving the desired relative compaction. Compaction over the landfill may be an issue because of potential problems with the soft (refuse) subgrade.

Landfill settlement will be monitored throughout the RI by surveying changes in benchmarks that were installed during the Limited Field Investigation. If substantial settlement is still

**Table 7-2
SUMMARY OF SAMPLING AND ANALYSIS PROGRAM FOR EXISTING CAP AND HOT SPOTS**

Medium	Analysis	Target Detection Limits	Proposed Analytical Method	Source of Analysis	No. of Samples ^a	Field and Rinsate Blanks	Trip Blanks ^b	Replicates	Additional Volume Needed for QA/QC Lots
Existing Cap	Moisture Content ^{c,d}	--	ASTM 2216-80	Geotech Lab	7	--	--	--	--
	Permeability Test ^{c,d}	--	SW 842 Method 9100	Geotech Lab	7	--	--	--	--
	In Situ Density ^{c,d}	--	--	Geotech Lab	7	--	--	--	--
	Atterberg Limits ^{c,d}	--	ASTM D4318	Geotech Lab	7	--	--	--	--
	Grain Size	--	ASTM D422	Geotech Lab	7	--	--	--	--
Hot Spot	TCL BNA Extractables	CRDL	Organic SOW87	CLP-RAS	36	1/day each	--	1/20 samples	Double volume per 20 samples
	TCL Pesticides/PCBs	CRDL	Organic SOW87	CLP-RAS	36	1/day each	--	1/20 samples	Double volume per 20 samples
	TCL Volatile Organics	CRDL	Organic SOW87	CLP-RAS	36	1/day each	1/day	1/20 samples	Double volume per 20 samples
	TAL Inorganics	CRDL	Inorganic SOW88	CLP-RAS	36	1/day each	--	1/20 samples	Double volume per 20 samples
	Cyanide	CRDL	Inorganic SOW88	CLP-RAS	36	1/day each	--	1/20 samples	Double volume per 20 samples
	Mercury	CRDL	Inorganic SOW88	CLP-RAS	36	1/day each	--	1/20 samples	Double volume per 20 samples

CRDL -- Contract Required Detection Limit

TCL -- Target Compound List

TAL -- Target Analyte List

RAS -- Routine Analytical Service

CLP -- Contract Laboratory Program

BNA -- Base Neutral and Acid

^aGeotechnical test samples correspond to one sample per cap investigation test pit. Analytical samples for the hot spot area correspond to 12 samples per source (hot spot) test pit.

^bTrip blanks are only necessary for volatile organic samples.

^cQC samples are not collected for geotechnical samples. Sample results are reviewed an experienced geotechnical engineer for conformity with the specified ASTM method.

^dThe proposed analytical method for in situ density is reported in *Methods of soil Analysis*, Section 13.2.

occurring, then a temporary cap may need to be designed and installed until the settlement rate has decreased.

7.1.3.6 Subtask 3F--Source Testing, Test Pits

The objectives of the source testing program are: (1) to evaluate the integrity of the buried drums, (2) determine the extent of contamination of unsaturated soil in the solvent disposal area, and (3) determine the approximate volume of the hot spot(s). The test pit excavation will be done in the one-half acre area believed to be used for drum disposal. Personnel will conduct sampling of the test pits in Level B protection.

Test pit depths are limited by the stability of subsurface materials and the maximum depth of the backhoe. Backhoes typically can reach depths of at least 25 feet below grade, but actual test pit depths are expected to be less because of soil stability limitations. For this reason, the maximum depth of test pits is estimated to be 20 feet below grade. Specific excavating equipment cannot be identified until an excavating contractor has been selected, but it will probably be a track-mounted backhoe. Three test pits in the southeastern section of the landfill will be logged and photographed to document the subsurface conditions encountered. No attempt will be made to enter the pits, and samples will be collected directly from the backhoe bucket. Excavated portions of the existing cap will be kept for replacement of the cover and the excavated waste will be placed on plastic sheets in a separate area from that of the cover material to prevent contamination of surface soils.

If intact or crushed drums are encountered, the field excavation crew will leave them undisturbed. Drums will not be removed from test pits. Drummed materials will not be tested unless drums are degraded and leaking, as visually evidenced by the presence of liquids in the test pits around the drums; samples will be obtained from the backhoe. If a free-floating liquid layer is found, the pit will be lined with a sorbent material and closed immediately after samples of the liquid are collected.

Following completion of sampling and test pit logging, each test pit will be backfilled to grade. If a strong contaminant profile is observed in the test pit wall, the field excavation crew will backfill the test pit to roughly the same condition it was in before excavation. The most contaminated material based on HNu screening, will be backfilled into the test pit first with the least contaminated going in last. Any remaining excavated materials that can not be placed into the test pit will be left at the test pit location and covered with clean clay fill obtained from an offsite borrow area.

The qualitative data obtained from the field screening will be used in conjunction with visual and stratigraphic information derived from the test pit logging to select soil samples for submittal to the CLP for analyses. The chemical information obtained from the CLP analysis will be compared to the groundwater plume data to identify groundwater contaminant source areas. The chemical information will also characterize the type and concentration of contaminants in the source areas. This soil information is necessary to characterize the potential for future contaminant releases to the groundwater and to evaluate containment, treatment, and disposal alternatives for the hot spot in the FS.

The proposed location of the test pits is shown in Figure 7-2. A maximum of 36 test pit samples will be submitted for TCL and TAL analyses. This number assumes a maximum of 12 samples each from the three test pits. The actual number of samples will depend on field observations and actual test pit depth. Samples will be considered as having low or medium concentrations, depending on the HNu readings. Sampling methods and protocol will be discussed in detail in the SAP. Some or all of the soil samples may be depth-interval samples. Samples will be selected by depth, based on visual observations (e.g., soil staining); the concentrations or types of VOCs detected during the soil gas survey and stratigraphic relationships. The sampling team leader will decide on the depth interval after consultation in the field with the project hydrogeologist and chemist. A summary of the sampling and analysis program is presented in Table 7-2.

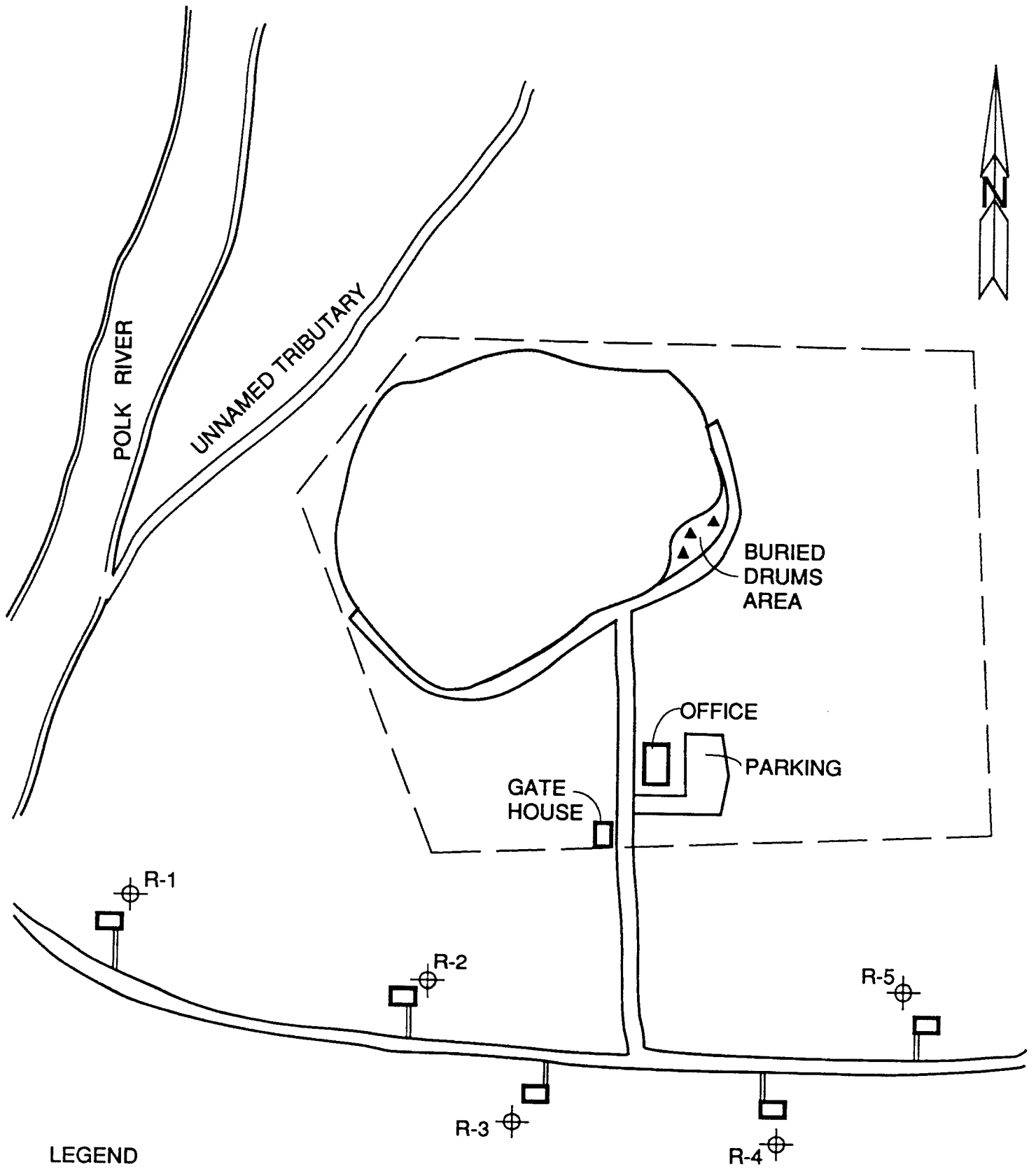

LEGEND

- ⊕ RESIDENTIAL WELLS
- ▲ SOURCE TEST PITS

**Figure 7-2
SOURCE TEST PITS
LOCATIONS
EXAMPLE SITE**

information on health and safety concerns for test pit excavations can be found in *Compendium of Superfund Field Operation Methods* (U.S. EPA, 1987c).

7.1.3.7 Subtask 3G--Hydrogeologic Investigation

The purpose of the hydrogeologic investigation is to accomplish the following:

- Refine the conceptual model of the groundwater flow system in relationship to underlying hydrostratigraphy
- Evaluate the aquifer properties and its response to pumping
- Locate monitoring wells for the collection of analytical data to define the type and extent of contamination
- Provide information on pathways for use in the risk assessment

Based on thorough review of existing data the following investigations are intended to fill in the data gaps and thereby fulfill the objectives listed above.

Geotechnical Borings. To refine the conceptual model and the subsurface stratigraphic relationships, and to aid in delineating the extent of the VOC plume in the vicinity of the landfill, eight soil borings, will be drilled and sampled (Figure 7-3). The rationale and proposed depth of each boring is presented in Table 7-3. The number and location of borings may change depending on the results of the initial borings. For instance, if soil contamination is found in borings west or east of the site, based on field observations and soil gas probe readings, additional borings would be installed upgradient northwest or northeast of the landfill. In the event that the stratigraphy is more complex or the groundwater contamination more extensive than that presented in the evaluation of existing data, a maximum of 16 more geotechnical borings may be required. The location for these borings will be based on the information developed

from the initial eight soil borings.

All borings will be advanced using a 6.25-inch (ID), screened hollow-stem auger. EPA will be responsible for obtaining easements and permits at all offsite locations.

Three of the soil borings will be advanced to bedrock, which is expected to be approximately 135 feet below ground surface. The other five borings will be advanced to a depth of about 70 feet below ground surface to determine the stratigraphy of the fill units beneath the south portion of the landfill and south of the landfill in the vicinity of the potential groundwater migration pathways. Each geotechnical boring will be sampled at 5-foot intervals using a standard split-spoon sampler following ASTM Standard D-1586 for the Standard Penetration Resistance Test. Boreholes where monitoring wells are not installed will be abandoned by injecting a thick bentonite slurry from the bottom of the borings to the ground surface using the tremie method.

Each boring will be logged by an experienced geologist, geotechnical engineer, or soil scientist. Samples will be described using the Unified Soil Classification System terminology. Samples will be collected for grain size analysis and/or Atterberg limits based on changes in stratigraphy. The decision to submit a sample for geotechnical analysis will be made in the field by the supervising geologist, engineer, or scientist but in no case will exceed three samples per boring.

Information obtained from the soil boring program will help to determine the need for additional monitoring wells and the depths at which monitoring wells will be installed. This stratigraphic information is also necessary to identify potential migration pathways and to evaluate the fate and transport of released contaminants.

Drill cuttings generated during the soil boring program will be collected and stockpiled onsite. These cuttings will be covered with clean clay fill obtained from an offsite borrow area. The cuttings will be consolidated with other waste under the final cap for the landfill.

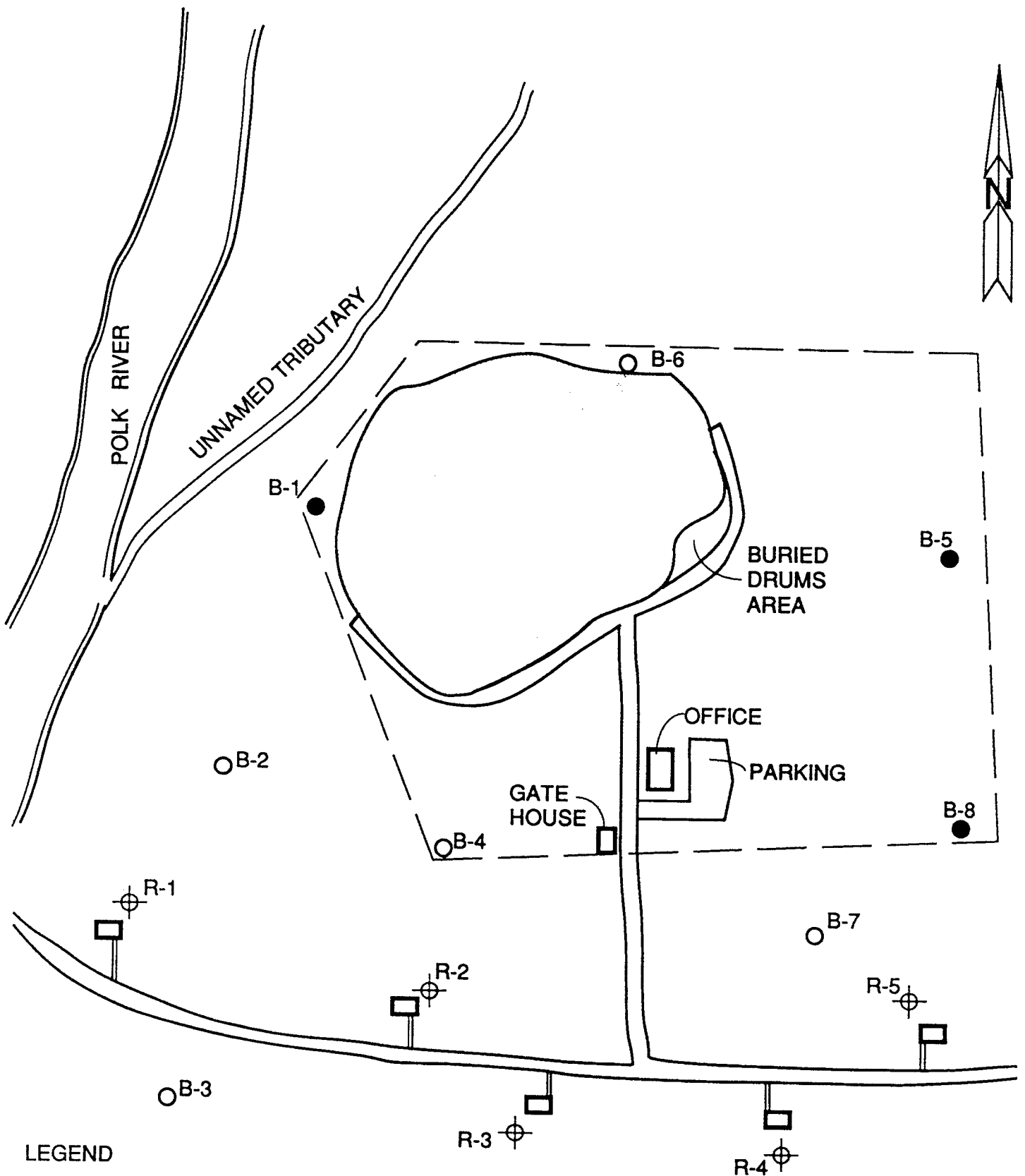

LEGEND

⊕ RESIDENTIAL WELLS

SOIL BORINGS:

● BEDROCK DEPTH

○ 70-FOOT DEPTH

**Figure 7-3
SOIL BORING
LOCATIONS
EXAMPLE SITE**

**Table 7-3
RATIONALE FOR SOIL BORING LOCATIONS FOR
THE EXAMPLE SITE**

Boring Location	Proposed Depth	Rationale
B-1	Bedrock	<ul style="list-style-type: none"> • Stratigraphy in west side of site where data are scarce, helps determine screen interval for monitoring wells
B-2	70 feet	<ul style="list-style-type: none"> • Stratigraphy in SW portion of the site where data are scarce, helps determine screen interval for monitoring wells
B-3	70 feet	<ul style="list-style-type: none"> • Helps determine location of downgradient monitoring nest
B-4	70 feet	<ul style="list-style-type: none"> • Helps determine location of downgradient monitoring nest, stratigraphy in SW corner of site where data are scarce
B-5	Bedrock	<ul style="list-style-type: none"> • Stratigraphy of potential migration pathways, helps locate monitoring wells, extent of contamination
B-6	70 feet	<ul style="list-style-type: none"> • Stratigraphy of potential migration pathways, helps locate monitoring wells, extent of contamination
B-7	70 feet	<ul style="list-style-type: none"> • Downgradient stratigraphy, helps locate monitoring wells, extent of contamination
B-8	Bedrock	<ul style="list-style-type: none"> • Stratigraphy in SE portion of the site, where data are scarce

Monitoring Well Installation. To better define potentiometric relationships in the vicinity of the site and evaluate the extent of groundwater contamination, 15 new monitoring wells will be installed and one existing well nest will be used. An onsite laboratory will be used during well installation to provide analytical results that will be used to reevaluate the proposed monitoring well network. Groundwater samples will be analyzed for selected VOCs and inorganic anions (chloride and sulfate) to aid in determining the extent of the groundwater plume. The inorganic anions are persistent chemicals which can be used as indicators of leachability and transport. Therefore, mapping elevated levels of these indicator chemicals relative to upgradient concentrations can give a more accurate picture of the movement of the groundwater and possible extent of the contaminant plume than just VOC analysis. Because of volatilization, adsorption and degradation, VOCs may diminish in concentrations more rapidly than the inorganic ions.

Potential locations for the new wells are shown in Figure 7-4. The rationale for each location is presented in Table 7-4. This rationale is based on the assumption that subsurface conditions are homogeneous. If subsurface conditions are heterogeneous, additional wells may be necessary. Also, based on the conceptual site model, it is possible that the horizontal or vertical extent of groundwater contamination may be greater than that estimated from existing data and the results of the VOC and inorganic ion analysis to be done by the onsite mobile laboratory, therefore an additional number of monitoring wells may be necessary. For purposes of this work plan, a maximum of 15 additional wells are estimated. The need for these wells and their locations will be assessed in the field by the project manager in conjunction with EPA's RPM.

One two-well monitoring well nest will be installed upgradient (background) of the landfill to determine upgradient groundwater quality. A second monitoring well nest (with three wells), in addition to the existing onsite landfill well nest, will be installed just off the southwest corner of the landfill to evaluate groundwater quality within the landfill.

Because there is an existing well nest onsite, and for health and safety reasons, installing an additional well nest onsite is not proposed. A third (two-well) and a fourth (three-well) nest is proposed to measure downgradient groundwater quality. Three single wells are proposed to measure the westward, eastward and southerly extent of groundwater contamination and to investigate the possible groundwater mound. One two-well monitoring well nest is proposed to evaluate the vertical distribution of contaminants downgradient of the landfill and to determine if a vertical gradient exists.

At least six of the remaining monitoring wells will be installed in geotechnical borings described earlier. These monitoring wells will be installed immediately after completion of the geotechnical borings at each location. The elevations of each monitoring well measuring point will be determined and water levels recorded. This information is needed to determine the groundwater flow system. The information obtained from completion of this task will be important to the analysis of the fate and transport of constituents released from the landfill and to the identification of contaminant migration pathways.

The boreholes for the monitoring wells will be advanced using screened hollow-stem augers (6.25-inch ID). This size allows sufficient annular space between the well and the auger wall to introduce a filter pack and seal. If alternative drilling methods are required, only methods using clear water, air, or cable tool will be considered.

Following installation, each monitoring well will be developed until substantially free of sediment, and until pH and conductivity are stable to the satisfaction of the project hydrogeologist. Wells will be developed using the surge-and-bail method. Well development water will be discharged as described under Section 7.1.3.12--RI-Derived Waste Disposal.

During installation of the 15 new wells, groundwater samples will be collected from three depths (water table, mid-depth, and above bedrock) at each location. These samples will be analyzed by the onsite mobile laboratory for

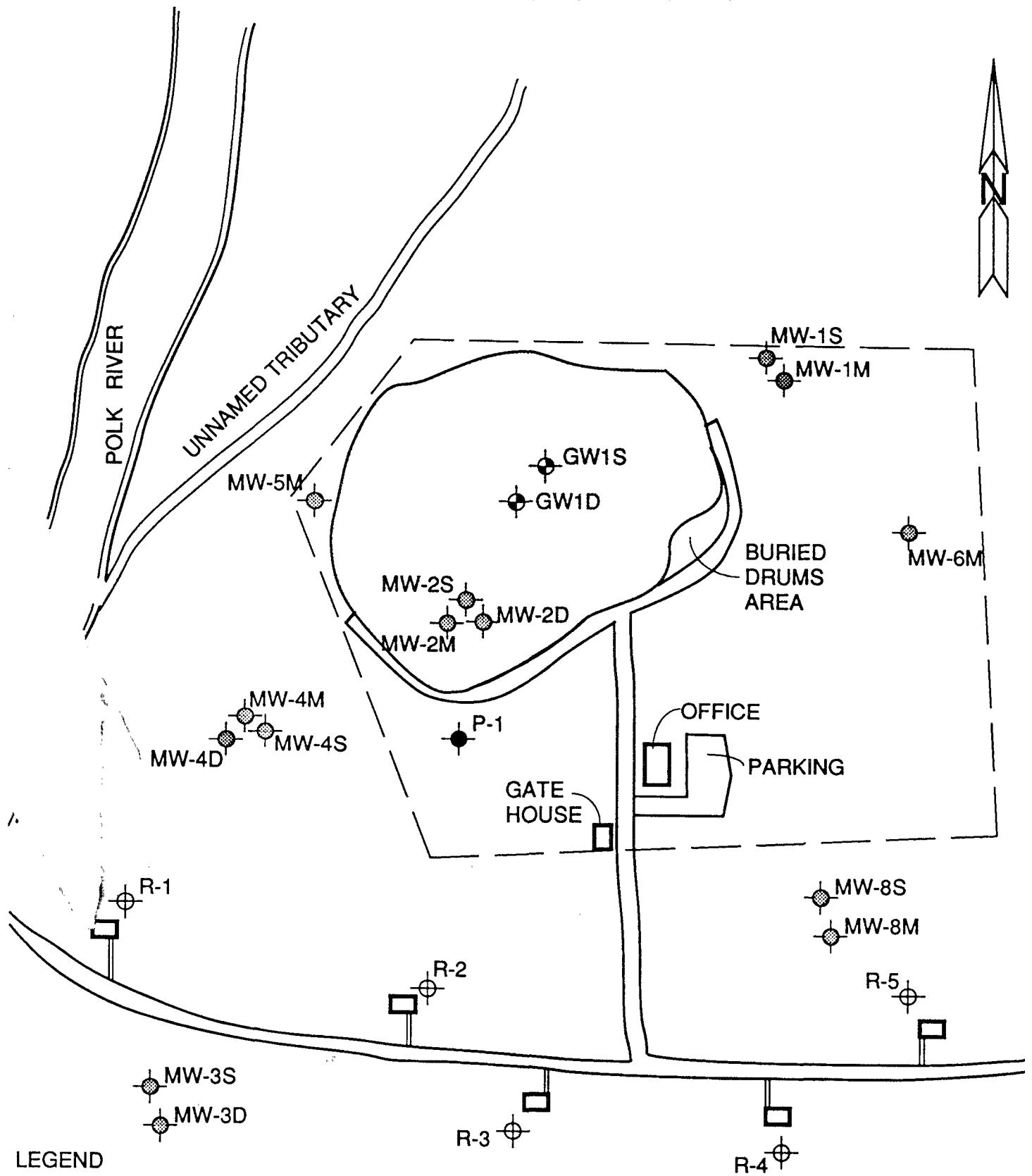

**Figure 7-4
PROPOSED MONITORING
WELL LOCATION
EXAMPLE SITE**

**Table 7-4
RATIONALE FOR MONITORING WELL LOCATIONS**

Well Number	Proposed Depth	Rationale for Location
MW-1S	45 feet	Can monitor quality of upgradient groundwater (background)
MW-1M	90 feet	
MW-2S	45 feet	Can monitor quality of groundwater migrating from the landfill (Samples will also be collected from existing onsite well nest.)
MW-2M	90 feet	
MW-2D	135 feet	
MW-3S	45 feet	Can monitor quality of downgradient groundwater and depth of contamination
MW-3D	135 feet	
MW-4S	45 feet	Can monitor quality of downgradient groundwater
MW-4M	90 feet	
MW-4D	135 feet	
MW-5M	70 feet	Can monitor westward extent of groundwater contamination
MW-6M	70 feet	Can monitor eastward extent of groundwater contamination
MW-7M	70 feet	Can monitor southward extent of groundwater contamination
MW-8S	45 feet	Can monitor quality of downgradient groundwater and depth of contamination
MW-8M	70 feet	

Note: Location of monitoring wells are dependent on results from the onsite mobile laboratory and soil gas analysis if performed.

four selected VOCs--1,1-dichlorethene (1,1-DCE), trichloroethene (TCE), 1,1,1,-trichloroethene (1,1,1-TCA), and toluene, and two inorganic ions--chloride and sulfate. The results will be plotted on site maps and will be used to evaluate the new monitoring well network. If the analytical results indicate high levels of the four VOCs and the two inorganic ions from the downgradient wells, then additional downgradient wells will be installed.

Water Level Monitoring. All new monitoring wells will be surveyed to establish horizontal location and elevation of the measuring points. Elevation measurements will be taken on the riser pipe with the measuring point designated by a chisel mark. All elevations will be referenced to the benchmark previously established at the site. All wells will be located horizontally to within plus or minus 5 feet. Vertical elevations of measuring points will be made to the nearest 0.01 foot.

Water levels will be collected at a maximum of one a month from new and existing monitoring wells for the duration of the RI. This is assumed to be 5 months. An electric water-level indicator graduated in 0.1-foot increments will be used.

Aquifer Tests. The purpose of the aquifer tests is to determine the physical characteristics of the underlying aquifer sufficiently to allow evaluation of groundwater collection alternatives. Both pumps tests and slug tests will be conducted.

This pump test is important for understanding how the aquifer responds to pumping given the site's proximity to constant-head boundaries. A 6-inch (minimum) ID, fully penetrating production well would be drilled using mud rotary techniques for the purpose of conducting a 72-hour pump test. Eight monitoring wells will be used as observation wells for this test. Groundwater samples will be collected during the pump test for analysis of CLP routine analysis of TCL organic and TAL inorganic packages. The layout of the pump and observation wells that will be used for the test is shown by Figure 7-4. The production well will be located in an area where it could be used later as a groundwater extraction well. The final location and depth of the screened interval will be selected in consultation

with the RPM after screening results of the groundwater and soil samples for the mobile laboratory are evaluated.

The pump test may generate up to 1,000 gpm for 3 days. This volume of water (4.3 million gallons) is too large to store onsite and will have to be discharged to the local POTW. Permission will have to be obtained from the POTW. If permission is not obtained, the pump test will not be performed and the slug test results will be used to characterize the hydraulic properties of the aquifer. The disadvantage of using only slug tests is that there is a higher degree of uncertainty in the parameter estimates and the influence of constant head boundaries is not determined.

Slug tests will also be performed to measure in-field hydraulic conductivity. Slug tests will be completed after the wells are developed. Tests will be conducted by either withdrawing a known volume of water or by inserting a cylinder of known dimension and recording changes in water level at the time.

7.1.3.8 Subtask 3H--Groundwater Sampling

Information obtained from the new monitoring wells will be used to study the possible groundwater mound and its effect on contaminant migration, to determine the vertical and lateral extent of the VOC contamination, and to evaluate source containment and groundwater extraction and treatment alternatives.

After well installation and recovery, groundwater samples will be collected from the new wells and from the existing landfill well nest. Groundwater sample collection will begin with the least contaminated wells and conclude with the most contaminated to prevent cross contamination of samples. Samples will be collected from within the hollow-stem auger after purging at least three well volumes to remove stagnant water or stratified contaminants and until the pH and conductivity are stable. Purge water will be collected or discharged on the ground as described in Section 4.2.3.12--RI-Derived Waste Disposal. Groundwater elevations will be measured before purging wells. Samples from each well will also be

submitted to the CLP for analysis of routine TCL organic and TAL inorganic packages, special analytical service (SAS) for vinyl chloride as well as for BOD, COD, TOC, and TDS. Efforts will also be made to identify Tentatively Identified Compounds (TIC) if they are detected in significant concentrations since they also could pose a human health risk. Field parameters of pH, temperature, and specific conductance will be measured at the time of sample collection. Details on sampling methods, collection of blanks and duplicates, preservation of samples, and sample handling and shipping will be presented in the SAP.

A second round of groundwater sampling will begin 4 months after completion of the first round to verify the previous results. Samples will be submitted to the CLP for the same analyses outlined above for round one. Field parameters will also be the same as above. A summary of the sampling and analysis program is presented in Table 7-5.

7.1.3.9 Subtask 3I--Residential Well Sampling

Residential wells in the vicinity of the landfill are sampled to verify reported contamination, to provide additional data as to the extent of contamination, and to identify wells that may not be affected by the contaminant plume.

To accomplish these objectives, a total of nine residential wells (shown in Figure 7-5) will be sampled during the two rounds of groundwater sampling. Five wells (R1-R5) will be sampled to provide additional data on the extent of groundwater contamination; the four remaining residential wells (R6-R9) are not anticipated to be contaminated and will be sampled only to verify that contamination has not migrated to them. Available information on the 9 wells including well depths and construction details was collected during limited field investigations.

Grab samples will be obtained from the cold water taps, at a point prior to treatment, after the wells have been adequately purged to remove stagnant water. Samples will be submitted for CLP analysis of routine TCL organic and TAL inorganic packages, except for the vinyl chloride analysis,

which will require a special analytical service (SAS) request. Efforts will also be made to identify TICs.

Homeowners will be contacted for permission to sample. Their requests with respect to the sampling schedule will be adhered to at all times. A well inventory form will be completed for each well sampled.

7.1.3.10 Subtask 3J--Leachate Sampling

There is no existing data on either the observed leachate seep or leachate within the landfill. The objectives of the leachate study are to identify the approximate amount of leachate production and the composition of the leachate. Composition information will be used to characterize the leachate and to determine compatibility of leachate treatment with groundwater treatment.

The leachate seep located on the west side of the landfill will be sampled twice. Grab samples will be taken at the toe of the landfill. One sample will be taken at the same time as the surface water sampling presented below. The other sample will be taken in the spring after a wet period when the flow from the seep is higher than normal. These two samples will indicate the range of composition of the leachate seep. Leachate seep samples will be analyzed for TCL organics, TAL inorganics, BOD, COD, pH, TDS, and oil and grease.

Water quality and wellhead data from the groundwater monitoring wells will be used to aid in the estimation of leachate composition and production. The data from the shallow well within the landfill will be a useful source of this data. Sampling of these wells was covered under Subtask 3H. A summary of the sampling and analysis program is presented in Table 7-5.

7.1.3.11 Subtask 3K--Surface Water and Sediment Sampling

No existing data on surface water and sediment contamination of the unnamed tributary to the Polk River are available. As discussed in Section 4.3 of this appendix, site contaminants may have migrated by way of surface runoff and groundwater recharge. To determine if this has

**Table 7-5
SUMMARY OF SAMPLING AND ANALYSIS PROGRAM FOR GROUNDWATER**

Medium	Analysis	Target Detection Limits	Proposed Analytical Method	Source of Analysis	No. of Samples ^a	Field and Rinsate Blanks	Trip Blanks ^b	Replicates	Additional Volume Needed for QA/QC Lots
Groundwater	TCL BNA Extractables	CRDL	625	CLP-RAS	52	1/day each	--	1/20 samples	Triple volume per 20 samples
	TCL Pesticides/PCBs	CRDL	625	CLP-RAS	52	1/day each	--	1/20 samples	Triple volume per 20 samples
	TCL Volatile Organics (prepurge and purged samples)	0.5 ppb	524.2	CLP-SAS	52	1/day each	1/day	1/20 samples	Triple volume per 20 samples
Groundwater	TAL Inorganics - Metals	CRDL	200.7	CLP-RAS	52	1/day each	--	1/20 samples	Double volume per 20 samples
	- Cyanide	CRDL	335.2	CLP-RAS	52	1/day each	--	1/20 samples	Double volume per 20 samples
	Biochemical Oxygen Demand (BOD)	--	507	Non-CLP	34	--	--	1/20 samples	--
	Chemical Oxygen Demand (COD)	--	410	Non-CLP	34	--	--	1/20 samples	--
	Total dissolved Solids (TDS)	--	209	Non-CLP	34	--	--	1/20 samples	--
	Total Organic Carbon (TOC)	--	415.1	Non-CLP	34	--	--	1/20 samples	--

CRDL -- Contract Required Detection Limit

TCL -- Target Compound List

TAL -- Target Analyte List

SAS -- Special Analytical Service

RAS -- Routine Analytical Service

CLP -- Contract Laboratory Program

BNA -- Base Neutral and Acid

TOC-- Total Organic Carbon

^aTwo rounds of sampling from 26 wells (15 new wells, 2 existing wells, 9 residential wells). Only the 17 monitoring wells (not residential wells) will be analyzed for BOD, COD TDS, and TOC.

^bTrip blanks are only necessary for volatile organic samples.

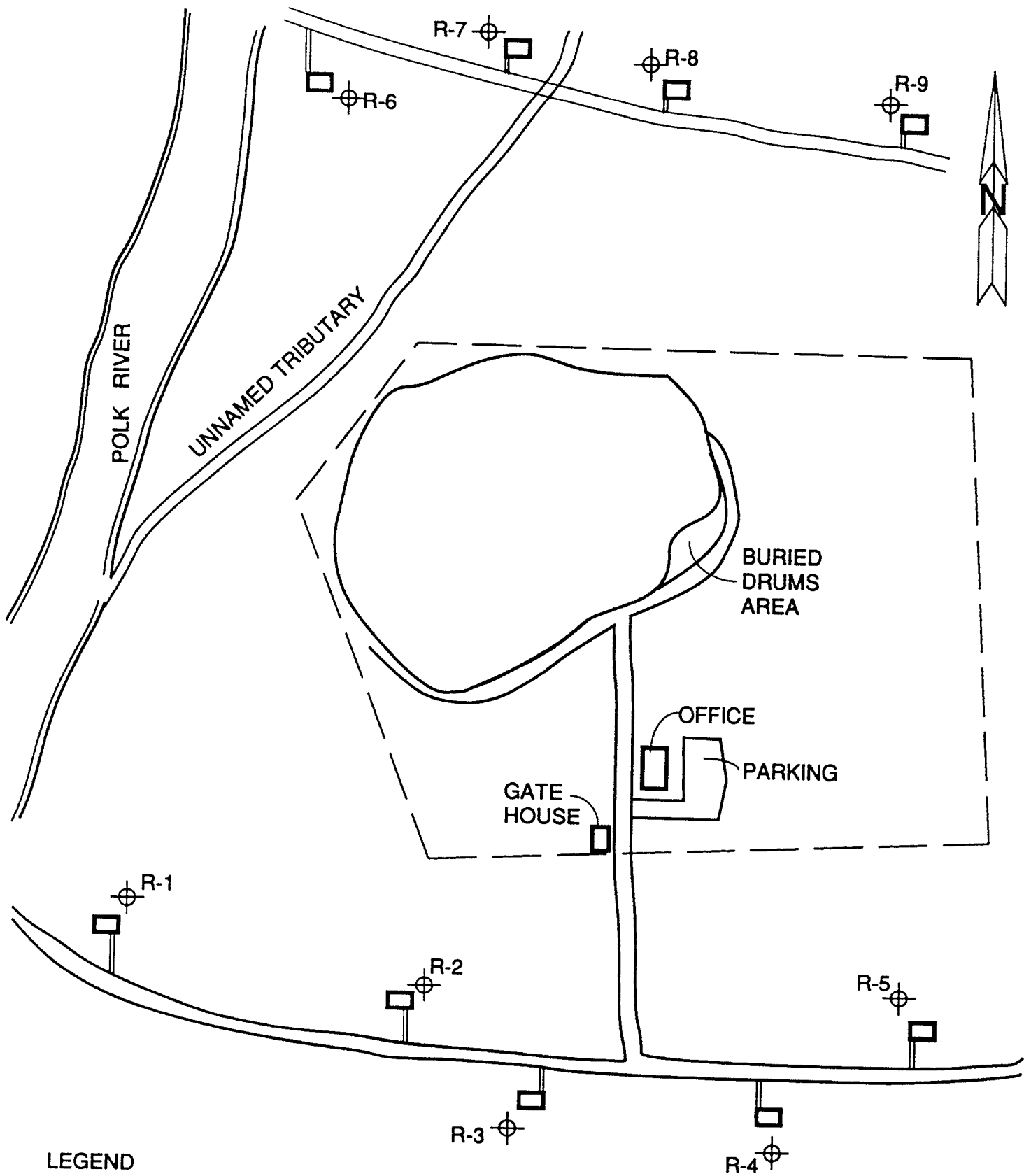

**Figure 7-5
RESIDENTIAL WELL
SAMPLING LOCATION
EXAMPLE SITE**

happened, four surface water and sediment samples will be collected from the stream and submitted for CLP analysis of routine TCL organics and TAL inorganics and toxicity testing. One of the sampling locations will be upgradient of the landfill to determine background levels in the river. Two locations will be along the banks of the river closest to the landfill and the remaining location will be downgradient of the landfill. These locations are shown in Figure 7-6. The sampling will occur in midsummer during a period of relatively low stream flow to determine maximum groundwater impact on the stream. A summary of the sampling and analysis program is presented in Table 7-6.

7.1.3.12 Subtask 3L--Landfill Gas Emissions Sampling

Significant amounts of methane and other gases such as vinyl chloride are typically generated by decomposition of the materials within the landfill. These gases will be sampled during Phase I to support an evaluation of the extent of gas migration into the soil surrounding the landfill and the rate of contaminant emissions to the ambient air. To accomplish this objective, eight onsite gas probes will be installed within the landfill, six offsite gas probes will be installed along the southern border of the site near the residential area, and three offsite gas probes will be installed along the northern border. The proposed landfill gas sampling locations are shown in Figure 7-7.

The probes will be placed to a depth of at least 5 feet. The collection procedures for methane gas are the same as those described in Section 7.1.3.4 for soil gas sampling.

7.1.3.13 Subtask 3M--RI-Derived Waste Disposal

Wastes derived from the RI field tasks will include: drill cuttings from monitoring well installation; water produced from equipment decontamination, well development, groundwater sampling, and aquifer testing. Field clothes and assorted trash will also be stored, but separately from the other waste, for final disposal.

Cuttings will be generated as the monitoring wells are drilled. Some monitoring wells will be cored for their entire length; therefore, most material removed from these holes will be as core and will be retained for logging and future reference. All cuttings will be collected and stockpiled onsite. These cuttings will need to be addressed when the final alternative is implemented.

All water generated during equipment decontamination and well development will be stored onsite. Water from the pump test will need to be discharged to the local POTW because the quantities are too large for onsite Storage.

Drilling equipment decontamination will typically consist of high-pressure steam cleaning. An area will be designated at the site for this purpose and berms will be built around the area for runoff control. The area will be lined with an HDPE liner and the water collected for storage.

7.1.4 Task 4--Sample Analysis and Data Validation

7.1.4.1 Subtask 4A--Onsite Mobile Laboratory

This subtask includes mobilization, operation, and demobilization of the mobile laboratory at the landfill site. The mobile laboratory will be used for screening groundwater and soil samples for target VOCs using a portable gas chromatograph unit. All analytical data will be tabulated and organized for agency review in the field. The screening data will be used to direct other field operations, including future drilling on monitoring wells and test pit sampling. Samples will be selected for CLP analysis based on screening results.

7.1.4.2 Subtask 4B--Data Validation

Upon completion of sample analysis, Sample Management Office (SMO) receives the data packages from the CLP laboratories and distributes them to the Contract Project Management Section (CPMS) of the Regional Environmental Services Division (ESD). The

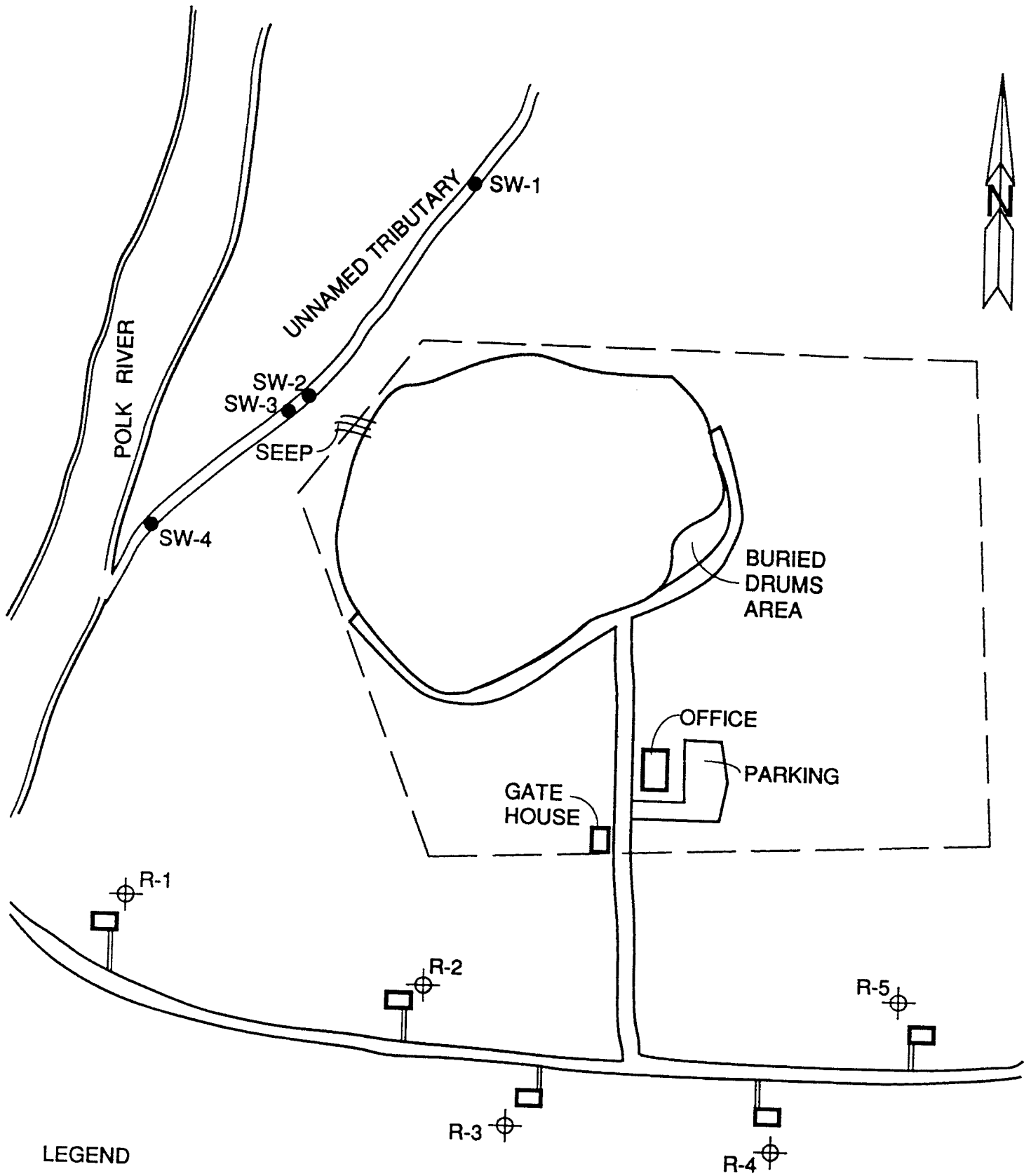

LEGEND

- ⊕ RESIDENTIAL WELLS
- SURFACE WATER SAMPLING SITES

**Figure 7-6
SURFACE WATER
SAMPLING LOCATIONS
EXAMPLE SITE**

**Table 7-6
SUMMARY OF SAMPLING AND ANALYSIS PROGRAM FOR
SURFACE WATER, SEDIMENT, AND LANDFILL GAS**

Medium	Analysis	Target Detection Limits	Proposed Analytical Method	Source of Analysis	No of. Samples	Field and Rinsate Blanks	Trip Blanks	Replicates	Additional Volume Needed for QA/QC Lots
Leachate (Seep)	TCL BNA Extractables	CRDL	625	CLP-RAS	2	1/day each	--	1/20 samples	Triple volume per 20 samples
	TCL Volatile Organics	CRDL	624	CLP-RAS	2	1/day each	1/day	1/20 samples	Triple volume per 20 samples
	TAL Inorganics	CRDL	200.7	CLP-RAS	2	1/day each	--	1/20 samples	Double volume per 20 samples
Surface Water (Stream)	TCL BNA Extractables	CRDL	625	CLP-RAS	4	1/day each	--	1/20 samples	Triple volume per 20 samples
	TCL Volatile Organics	CRDL	624	CLP-RAS	4	1/day each	1/day	1/20 samples	Triple volume per 20 samples
	TAL Inorganics	CRDL	200.7	CLP-RAS	4	1/day each	--	1/20 samples	Double volume per 20 samples
Sediment (Stream)	TCL BNA Extractables	CRDL	625	CLP-RAS	4	1/day each	--	1/20 samples	Triple volume per 20 samples
	TCL Volatile Organics	CRDL	624	CLP-RAS	4	1/day each	1/day	1/20 samples	Triple volume per 20 samples
	TAL Inorganics	CRDL	200.7	CLP-RAS	4	1/day each	--	1/20 samples	Double volume per 20 samples
Landfill Gas	Methane, TCE, VC	*	T014	non-CLP	17	--	--	1/20 samples	--

CRDL – Contract Required Detection Limit

TCL -- Target Compound List

TAL – Target Analyte List

TCE – Trichlorethylene

*The target detection limit for methane is dependent on the volume of gas sampled and should be established for each sampling event.

VC -- Vinyl Chloride

RAS -- Routine Analytical Service

CLP – Contract Laboratory Program

BNA -- Base Neutral and Acid

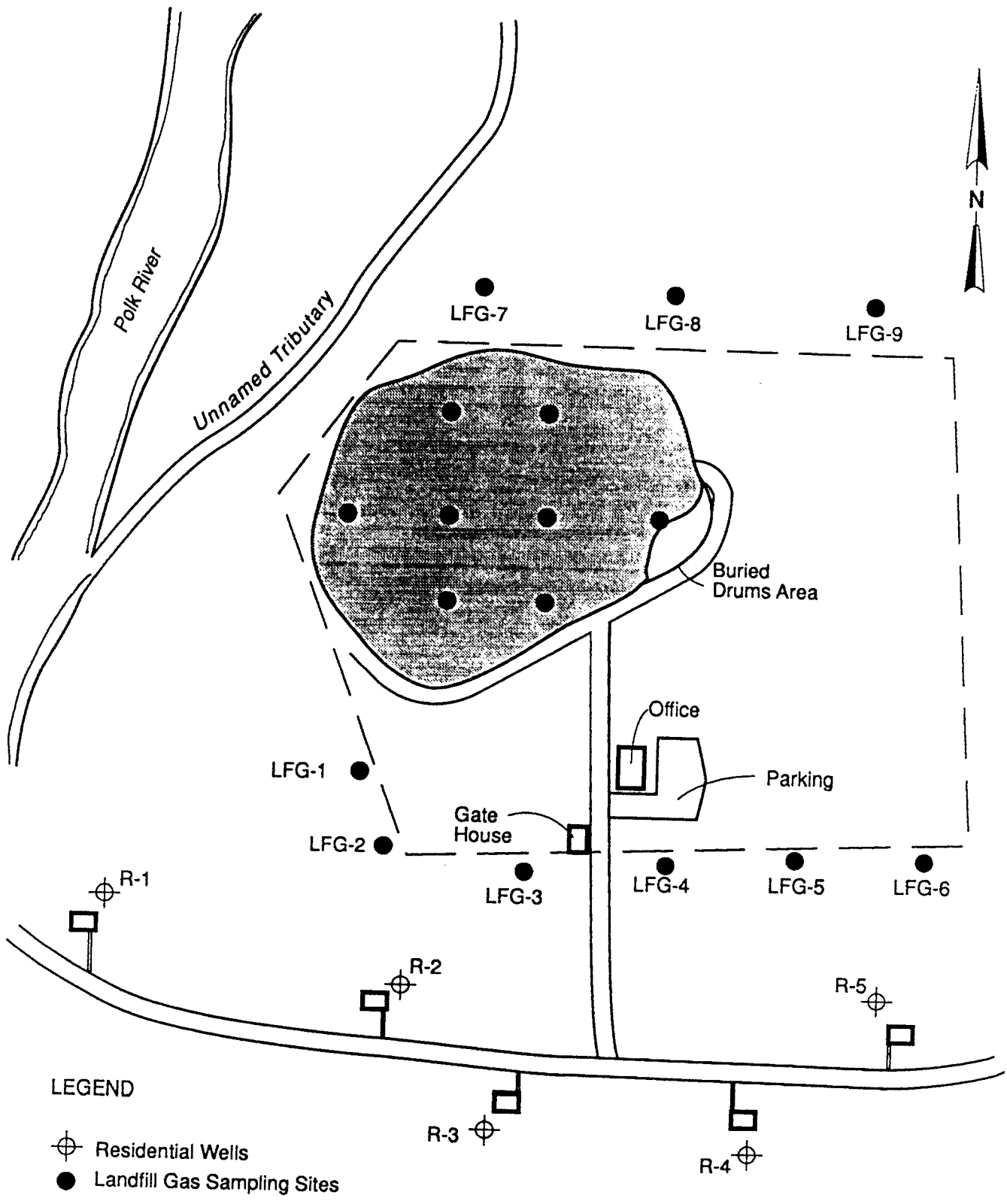

**Figure 7-7
LANDFILL GAS SAMPLING
TEST PIT LOCATION
EXAMPLE SITE**

CPMS reviews all data packages resulting from regional sampling efforts.

After the ESD-reviewed data packages are received they will be reviewed before interpretation by the project staff. Any data noted in the review that should be qualified will be flagged with the appropriate symbol. Results for field blanks and field duplicates will also be reviewed (these may or may not be considered by the CPMS) and the data further qualified if necessary. The data set as a whole will also be examined for consistency, anomalous results, and whether or not the data are reasonable for the samples involved.

Any limitations on the use of the analytical data based on the data review and the CLP QA/QC comments will be identified. Limitations of the analytical data will be presented in the RI report.

7.1.5 Task 5--Data Evaluation

Specific analyses and evaluations to be performed under the Data Evaluation subtask will include:

- Preparing groundwater contour plots for all identified hydrostratigraphic units
- Computing vertical and horizontal hydraulic gradients and evaluating groundwater flow direction in each stratigraphic unit
- Generating figures showing spatial and, when applicable, temporal distributions of contaminants in soil and groundwater

7.1.6 Task 6--Risk Assessment

The risk assessment will be consistent with EPA methods as outlined in the documents *Risk Assessment Guidance for Superfund, Volume I--Human Health Evaluation Manual (Part A)* (U.S. EPA, 1989b) and *Risk Assessment Guidance for Superfund, Volume II--Environmental Evaluation Manual* (U.S. EPA, 1989c). The results of the assessment will be included as a chapter in the RI Report, Supporting risk, transport, and fate calculations will be appended, and relevant references will be cited.

Based on the risk assessment, EPA will develop cleanup levels to guide the selection of remedial measures for media where either ARARs do not exist or where the ARARs are not protective. These proposed criteria will be developed by EPA with contractor input on the technical issues.

7.1.7 Task 7--Remedial Investigation Report

A report summarizing RI activities and findings will be prepared and submitted to the EPA for review and comment. Early chapters of the report summarizing the field investigation activities and the analytical data will be submitted to U.S. EPA as early as possible to aid in identification of ARARs which will be finalized during the FS. The RI report will also be submitted to the Agency for Toxic Substance and Disease Registry to assist in their health assessment of the site. The RI report will be prepared in accordance with the current *RI/FS Guidance* (U.S. EPA, 1988a).

7.1.8 Task 8--Remedial Action Alternative Development

The purpose of developing remedial action alternatives is to produce a reasonable range of waste management options to be analyzed more fully in the detailed analysis of alternatives. Developing alternatives includes the following elements:

- Establishing remedial action objectives
- Developing general response actions
- Identify and screen technologies and process options
- Combining medium-specific technologies to form alternatives
- Screening alternatives, if necessary

Section 4.1 of this appendix presents the preliminary identification of remedial actions alternatives for the example site. The preliminary remedial action objectives and subsequent remedial action alternatives are based on results of the limited site investigation, preliminary

remedial goals, experience at municipal landfill sites, and engineering judgment.

These preliminary remedial action alternatives will be refined on the basis of the information collected during the RI. Additional alternatives such as direct remediation of surface water and sediments may need to be developed depending on the findings of the risk assessment. As required, a no-action alternative will also be retained through the development and evaluation of the alternatives process.

Sections 5 and 6 in the body of this report (*Conducting Remedial Investigations/Feasibility Studies for CERCLA Municipal Landfill Sites*) should be referred to for additional information on the development, evaluation, and selection of remedial action alternatives for the example site.

7.1.9 Task 9--Alternatives Evaluation

The final alternatives will be evaluated to provide EPA with a framework with which to select a remedy for the site. The detailed analysis of these alternatives will be conducted in three stages: further refinement, individual analysis, and comparative analysis.

Further refinement of the alternatives will include developing detailed information such as:

- Identifying design parameters for technology components such as landfill cap and groundwater treatment system
- Quantifying amounts of contaminated soils (and possibly sediments) to be handled
- Estimating time of implementation for construction activities
- Estimating O&M requirements, particularly for a groundwater pump and treatment system and a landfill gas treatment system
- Process sizing

This information will be used to develop a cost estimate to within +50 percent to -30 percent.

During the individual analysis, each alternative will

be evaluated with respect to the following nine evaluation criteria:

- Overall protection of human health and the environment
- Compliance with ARARs
- Long-term effectiveness and permanence
- Reduction of toxicity, mobility, or volume through treatment
- Short-term effectiveness
- Implementability
- Cost
- State acceptance
- Community acceptance

Detailed descriptions of each of the above criteria are reported in the *RI/FS Guidance* (U.S. EPA, 1988a).

Following the individual analysis, a comparative analysis will be performed. The comparative analysis will lead to the development of a description of the strengths and weaknesses of the alternatives relative to one another. Not all the criteria will be used in this evaluation; just those that illustrate significant differences among the alternatives. As part of this evaluation, there will be an analysis of how a change in the uncertainties or assumptions made in the analysis may change the performance of the alternatives.

7.1.10 Task 10--Feasibility Study Report

Following completion of the detailed evaluation task, the Contractor will prepare and submit a draft FS report for the example site to EPA for review and comment. The report will summarize FS activities and RI site characterization results and will be prepared in accordance with *RI/FS Guidance* (U.S. EPA, 1988a). Information developed during the FS such as identification of ARARs, detailed description of alternatives, and detailed evaluation of alternatives will

be provided to EPA for review as these items are completed, in order to obtain input from the Agency during the evaluation process.

7.1.11 Task 11--Treatability Studies

Any necessary laboratory, bench, or pilot scale treatability studies required to evaluate the effectiveness of remedial technologies and establish engineering criteria will be identified as early as possible. Should laboratory studies be required, a testing plan for the studies will be prepared and presented to EPA for review

and approval. This testing plan will identify the types and goals of the studies, the level of effort needed, a schedule for completion, and the data management guidelines. Upon EPA approval, a test facility and any necessary equipment, vendors, and analytical services will be procured. Upon completion of the testing, the results will be evaluated to assess the technologies with respect to the goals identified in the test plan. A report summarizing the testing program and its results will be prepared and presented in the final FS report.

Section 8

COST AND KEY ASSUMPTIONS

The work plan should present a section that contains a cost estimate for conducting the RI/FS. The key assumptions used in preparing this estimate should also be presented. This section will follow the same approach used in all RI/FS work plans and is not discussed here because it is covered in the RI/FS guidance (U.S. EPA, 1988a).

Section 9

SCHEDULE

The schedule preparation for municipal landfill sites does not differ in approach from typical RI/FS work plans and is therefore not presented in this example.

Section 10
PROJECT MANAGEMENT

Project management activities, such as staffing and coordination for municipal landfill sites, does not differ in approach from other types of sites and is therefore not covered in this example.

Section 11 BIBLIOGRAPHY

U.S. Environmental Protection Agency, National Enforcement Investigation Center (NEIC). *Policies and Procedures for Sample Control*. 1986.

U.S. Environmental Protection Agency. *Data Quality Objectives for Remedial Response Activities*. EPA/540/6-87/003. March 1987a.

U.S. Environmental Protection Agency. *Health Advisories for 25 Organics*. March 1987b.

U.S. Environmental Protection Agency. *Compendium of Superfund Field Operations Methods*. EPA/540/P-87/001. December 1987c.

U.S. Environmental Protection Agency. *Guidance for Conducting Remedial Investigations and Feasibility Studies under CERCLA*. Interim Final. EPA/540/G-89/004. October 1988a.

U.S. Environmental Protection Agency. *User's Guide to the Contract Laboratory Program*. EPA/540/8-89/012. December 1988b.

U.S. Environmental Protection Agency. *Integrated Risk Information System*. June 1989a.

U.S. Environmental Protection Agency. *Interim Final, Risk Assessment Guidance for Superfund, Volume 1, Human Health Evaluation Manual, Part A*. December 1989b.

U.S. Environmental Protection Agency. *Risk Assessment Guidance for Superfund. Volume II. Environmental Evaluation Manual*. Interim Final. EPA/540/1-89/001. March 1989c.

Appendix B

Remedial Technologies Used
at Landfill Sites

Appendix B-1
RODS REVIEWED FOR THE MUNICIPAL LANDFILL STUDY

Page 1 of 5

Region	Site	ROD Date(s)
Region I	Auburn Road Landfill, NH	9/17/86 9/29/89
	Beacon Heights, CT	9/23/85
	Charles George, MA	12/29/83 7/11/85 9/29/88
	Davis Liquid, RI	9/29/87
	Iron Horse, MA	9/15/88
	Kellogg-Deering Well Field, CT	9/17/86 9/29/89
	Landfill & Resource Recovery, RI	9/29/88
	Laurel Park, CT	6/30/88
	Old Springfield, VT ^a	9/22/88
	Winthrop Landfill, ME	11/22/85
Region II	Combe Fill North, NJ	9/29/86
	Combe Fill South, NJ	9/29/86
	Florence Landfill, NJ	6/27/86
	GEMS Landfill, NJ	9/27/85
	Helen Kramer, NJ	9/27/85
	Kin-Buc Landfill, NJ	9/30/88
	Lipari Landfill, NJ	8/03/82 9/30/85 7/11/88

^aSource control ROD has not yet been completed; only groundwater remedy (i.e., management of migration) has been implemented.

Appendix B-1
RODS REVIEWED FOR THE MUNICIPAL LANDFILL STUDY

Page 2 of 5

Region	Site	ROD Date(s)
Region II (Continued)	Lone Pine Landfill, NJ	9/28/84
	Ludlow Sand & Gravel, NY	9/30/88
	Old Bethpage, NY	3/14/88
	Port Washington Landfill, NY	9/30/89
	Price Landfill, NJ ^a	9/20/83 9/29/86
	Ringwood Mines, NJ	9/29/88
	Sharkey Landfill, NJ	9/29/86
	South Brunswick Landfill, NJ	9/27/87
	Volney Landfill, NY	7/31/87
Region III	Army Creek, DE	9/29/86
	Blosenski Landfill, PA	9/29/86
	Craig Farm Drum, PA	9/29/89
	Delaware Sand & Gravel, DE	4/29/88
	Dorney Road Landfill, PA	9/29/88
	Henderson Road, PA	6/01/88 9/29/89
	Enterprise Avenue, PA	5/10/84
	Heleva Landfill, PA	3/22/85
	Industrial Lane, PA ^a	9/29/86
	Moyer Landfill, PA	9/30/85
	Reeser's Landfill, PA	3/20/89

^aSource control ROD has not yet been completed; only groundwater remedy (i.e., management of migration) has been implemented.

Appendix B-1
RODS REVIEWED FOR THE MUNICIPAL LANDFILL STUDY

Page 3 of 5

Region	Site	ROD Date(s)
Region III (Continued)	Strasburg Landfill, PA	3/30/89
	Tybouts Corner, DE	3/06/86
	Wildcat Landfill, DE	6/29/88 9/30/88
Region IV	Airco, KY	6/24/88
	Amnicola Dump, TN	3/30/89
	Davie Landfill, FL	9/30/85
	Goodrich, KY	6/24/88
	Hipps Road Landfill, FL	9/03/86
	Kassouf-Kimberling, FL	9/30/89
	Lees Lane Landfill, KY	9/25/86
	NW 58th Street Landfill, FL	9/21/87
	Newport Dumpsite, KY	3/27/87
	Powersville Landfill, GA	9/30/87
Region V	Belvidere Landfill, IL	6/29/88
	Bowers Landfill, OH	3/31/89
	Cemetery Dumps, MI	9/11/85
	Cliff/Dow Dumps, MI	9/27/87
	Coshocton City Landfill, OH	6/17/88
	E.H. Schilling, OH	9/29/89 2/29/84
	Forest Waste, MI	3/31/88

^aSource control ROD has not yet been completed; only groundwater remedy (i.e., management of migration) has been implemented.

Appendix B-1
RODS REVIEW FOR THE MUNICIPAL LANDFILL STUDY

Page 4 of 5

Region	Site	ROD Date(s)
Region V (Continued)	Fort Wayne, IN	8/26/88
	Industrial Excess, OH	9/30/87 7/17/89
	Ionia City Landfill, MI	9/29/88
	Kummer Landfill, MN	6/12/85 9/30/88
	Lake Sandy Jo, IN	9/26/86
	Liquid Disposal, MI	9/30/87
	Marion/Bragg, IN	9/30/87
	Mason County, MI	9/28/88
	Metamora Landfill, MI	9/30/86
	Miami County, OH	6/30/89
	Mid-State, WI	9/30/88
	New Lyme Landfill, OH	9/27/85
	Northside, IN	9/25/87
	Oak Grove Landfill, MN	9/30/88
	Schmalz Dump, WI	8/13/85 9/30/87
	Spiegelberg, MI	9/30/86
Wauconda Sand & Gravel, IL	9/30/86	
Windom Dump, MN	9/29/89	

^aSource control ROD has not yet been completed; only groundwater remedy (i.e., management of migration) has been implemented.

Appendix B-1
RODS REVIEWED FOR THE MUNICIPAL LANDFILL STUDY

Page 5 of 5

Region	Site	ROD Date(s)
Region VI	Bayou Sorrel, LA	11/14/86
	Cecil Lindsey, AR	4/23/86
	Cleve Reber, LA	3/31/87
	Compass Industries, OK	9/29/87
	Industrial Waste Control, AR	6/28/88
Region VII	Arkansas City Dump, KS	9/21/89
	Conservation Chemical, MO	9/27/87
	Doepke Disposal, KS	9/21/89
	Fulbright/Sac River Landfill, MO	9/30/88
	Todtz, Lawrence Farm, IA	11/4/88
Region VIII	Marshall Landfill, CO	9/26/86
Region IX	Jibboom Junkyard, CA	5/09/85
	Operating Industries, CA	7/31/87
		11/16/87
		9/30/88
	Ordoy Disposal Site, GUAM	9/28/88
Region X	Colbert Landfill, WA	9/29/87
	Commencement Bay South Tacoma Channel, WA	3/31/88
	Northside Landfill, WA	9/30/89

^aSource control ROD has not yet been completed; only groundwater remedy (i.e., management of migration) has been implemented.

Appendix B2
Remedial Technologies Used at Landfill Sites

GENERAL RESPONSE ACTION/ Remedial Technologies Process Options	Region I										Region I Total
	Auburn Road	Beacon Heights	Charles George	Davis Liquid	Iron Horse	Kellogg Deering	Landfill & Res. Rec.	Laurel Park	Old Springfield	Winthrop Landfill	
SOILS/LANDFILL CONTENTS											
NO ACTION											0
ACCESS RESTRICTION		X				X	X			X	4
Deed Restrictions						X				X	2
Land Use Restrictions										X	1
Fencing		X					X			X	3
CONTAINMENT	X	X	X		X	X	X			X	7
Surface Controls					X	X				X	3
Grading										X	1
Revegetation					X	X					2
Cap	X	X	X			X	X			X	6
Clay Barrier										X	1
Multibarrier	X	X				X	X			X	5
Soil	X										1
Synthetic Membrane	X		X								2
REMOVAL/DISPOSAL		X		X	X	X					4
Excavation		X		X	X	X					4
Mechanical Excav.											0
Drum Removal											0
Consolidation						X					1
Disposal Onsite											0
RCRA Type Landfill											0
Disposal Offsite				X							1
SOIL TREATMENT											
Biological Treatment											0
Physical Treatment											0
Thermal Treatment				X							1
Incineration				X							1
Offsite Treatment											0
RCRA Incinerator											0
IN-SITU TREATMENT											
Biodegradation					X	X					1
Vitrification											0
Physical Treatment						X					1
Solidification/fixation											0
Vapor Extraction						X					1

11/14/90

Appendix B2
Remedial Technologies Used at Landfill Sites

GENERAL RESPONSE ACTION/ Remedial Technologies Process Options	Region I										Region I Total
	Auburn Road	Beacon Heights	Charles George	Davis Liquid	Iron Horse	Kellogg Deering	Landfill & Res. Rec.	Laurel Park	Old Springfield	Winthrop Landfill	
GROUNDWATER AND LEACHATE											
NO ACTION											0
Attenuation											0
Observation											0
MONITORING		X	X			X	X	X	X	X	7
INSTITUTIONAL CONTROLS		X	X			X		X	X		5
Alternate Water Supply	X	X	X	X						X	5
CONTAINMENT											0
Vertical Barriers											0
Slurry Wall											0
Horizontal Barriers			X								1
COLLECTION	X	X	X			X		X	X	X	7
Extraction	X	X	X			X		X	X	X	7
Extraction Wells						X		X			2
Ext/Injection Wells											0
Leachate Collection	X	X						X			3
Collection trench	X										1
Leachate Drain		X						X			2
Onsite Discharge											0
Aquifer Reinjection											0
Surface Discharge											0
Dewatering											0
Offsite Discharge						X					1
POTW						X					1
Land Application											0
TREATMENT			X	X		X		X			4
Biological Treatment			X								1
Activated Sludge											0
Chemical Treatment	X		X			X					3
Oxidation						X					1
Ion Exchange Treatment			X								1
Coagulant Addition	X										1
Metals Precipitation	X		X								2
pH Adjustment											0
Physical Treatment	X		X	X		X					4
Adsorption	X		X	X		X					4
Air Stripping	X			X		X					3
Sedimentation											0
Sand filtration											0
Flocculation											0
Lime pretreatment											0
Offsite Treatment								X			1
POTW								X			1

11/14/90

Appendix B2
Remedial Technologies Used at Landfill Sites

GENERAL RESPONSE ACTION/ Remedial Technologies	Region I Auburn	Beacon	Charles	Davis	Iron	Kellogg	Landfill & Res. Rec.	Laurel Park	Old Springfield	Winthrop Landfill	Region I Total

LANDFILL GAS											
COLLECTION		X								X	2
Passive Systems		X					X	X		X	4
Pipe Vents											0
Trench Vents											0
Active Vents			X								1
Extraction Wells			X								1
Blowers											0
TREATMENT							X				1
Thermal Destruction			X				X				2
Flaring							X				1
Activated carbon											0
MONITORING			X				X				2

SURFACE WATER AND SEDIMENTS											
Stormwater controls		X									1
Diversions			X								1
Removal Disposal (sediments)			X								1
Excavation			X								1
Offsite Disposal (sediments)											0
Treatment			X								1
Solidification			X								1
Dewatering					X						1
Thermal treatment											0

Appendix B2
Remedial Technologies Used at Landfill Sites

GENERAL RESPONSE ACTION/ Remedial Technologies Process Options	Region II Combe Fill North	Combe Fill South	Florence Land Recon.	Gloucester Environ. Mgmt. (GEMS)	Helen Kramer	Kin-Buc Landfill	Lipari Landfill	Lone Pine	Ludlow Sand	Old Bethpage	Port Washington	Price Landfill	Ringwood Mines	Sharkey Landfill	South Brunswick	Volney Landfill	Region II Total
SOILS/LANDFILL CONTENTS																	
NO ACTION																	0
ACCESS RESTRICTION	X	X	X	X	X									X			6
Deed Restrictions																	0
Land Use Restrictions																	0
Fencing	X	X	X	X	X			X				X			X		9
CONTAINMENT	X	X	X	X	X	X	X		X	X			X	X		X	12
Surface Controls	X							X	X				X	X		X	6
Grading	X							X					X			X	4
Revegetation													X				1
Cap	X	X	X	X	X	X	X		X	X	X			X	X	X	13
Clay Barrier	X		X		X				X	X	X						6
Multibarrier		X	X	X		X								X	X		6
Soil	X															X	2
Synthetic Membrane			X														1
REMOVAL/DISPOSAL													X				1
Excavation							X						X				2
Mechanical Excav.							X										1
Drum Removal																	0
Consolidation																	0
Disposal Onsite																	0
RCRA Type Landfill																	0
Disposal Offsite																	1
SOIL TREATMENT													X				0
Biological Treatment																	0
Physical Treatment																	0
Thermal Treatment							X										1
Incineration																	0
Offsite Treatment																	0
RCRA Incineration																	0
IN-SITU TREATMENT																	0
Biodegradation																	0
Vitrification																	0
Physical Treatment														X			1
Solidification/fixation														X			1
Vapor Extraction																	0

Appendix B2
Remedial Technologies Used at Landfill Sites

GENERAL RESPONSE ACTION/ Remedial Technologies Process Options	Region II Combe Fill North	Combe Fill South	Florence Land Recon.	Gloucester Environ. Mgmt. (GEMS)	Helen Kramer	Kin-Buc Landfill	Lipari Landfill	Lone Pine	Ludlow Sand	Old Bethpage	Port Washington	Price Landfill	Ringwood Mines	Sharkey Landfill	South Brinswick	Volney Landfill	Region II Total
GROUNDWATER AND LEACHATE																	
NO ACTION													X				1
Attenuation													X				1
Observation																	0
MONITORING	X	X	X		X	X		X		X	X		X	X		X	11
INSTITUTIONAL CONTROLS												X					1
Alternate Water Supply		X										X					2
CONTAINMENT			X		X	X	X	X							X	X	7
Vertical Barriers			X		X	X	X	X							X	X	7
Slurry Wall			X		X	X	X	X							X	X	7
Horizontal Barriers																	0
COLLECTION			X		X	X	X	X	X	X	X	X		X		X	11
Extraction		X	X	X	X	X	X	X	X	X	X	X		X		X	13
Extraction Wells		X		X			X	X	X		X	X					7
Ext/Injection Wells							X										1
Leachate Collection				X	X	X	X		X	X					X	X	8
Collection trench	X				X	X											3
Leachate Drain							X		X						X	X	4
Onsite Discharge																	0
Aquifer ReInjection										X							1
Surface Discharge																	0
Dewatering					X	X											2
Offsite Discharge						X	X										2
POTW						X	X										2
Land Application																	0
TREATMENT		X		X	X	X	X			X		X		X		X	9
Biological Treatment		X				X											3
Activated Sludge																	0
Chemical Treatment				X	X					X	X						4
Oxidation																	0
Ion Exchange Addition																	0
Coagulant Addition																	0
Metals Precipitation					X					X	X						3
PH Adjustment				X													1
Physical Treatment				X	X	X				X	X	X		X		X	8
Adsorption						X											2
Air Stripping				X	X					X	X	X		X			6
Sedimentation				X	X												2
Sand filtration																	0
Flocculation				X	X												2
Lime pretreatment												X					1
Offsite Treatment			X	X	X		X					X		X			6
POTW			X	X	X		X					X		X			6

11/14/90

Appendix B2
Remedial Technologies Used at Landfill Sites

GENERAL RESPONSE ACTION/ Remedial Technologies Process Options	Region II Combe Fill North	Combe Fill South	Florence Land Recon.	Gloucester Environ. Mgmt. (GEMS)	Helen Kramer	Kin-Buc Landfill	Lipari Landfill	Lone Pine	Ludlow Sand	Old Bethpage	Port Washington	Price Landfill	Ringwood Mines	Sharkey Landfill	South Brunswick	Volney Landfill	Region II Total
LANDFILL GAS																	
COLLECTION		X	X	X	X						X			X	X	X	8
Passive Systems	X		X											X	X	X	5
Pipe Vents			X														1
Trench Vents	X													X	X	X	4
Active Vents		X		X	X					X	X						5
Extraction Wells		X		X						X							3
Blowers		X			X					X	X						4
TREATMENT		X	X	X	X												4
Thermal Destruction		X	X	X	X					X							5
Flaring		X		X	X												3
Activated carbon			X	X	X												3
MONITORING		X	X							X	X				X		5
SURFACE WATER AND SEDIMENTS																	
Stormwater controls		X	X	X	X									X			5
Diversion																	0
Removal Disposal (sediments)			X	X	X												3
Excavation			X	X	X												3
Offsite Disposal (sediments)			X														1
Treatment																	0
Solidification																	0
Dewatering							X			X							2
Thermal treatment							X										1

11/14/90

Appendix B2
Remedial Technologies Used at Landfill Sites

GENERAL RESPONSE ACTION/ Remedial Technologies Process Options	Region III Army Creek	Blosenski Landfill	Craig Farm	Delaware Sand	Dorney Road	Enterprise Avenue	Heleva Landfill	Henderson Road	Industrial Lane	Moyer Landfill	Reeser's Landfill	Stratsburg Landfill	Tybouts Corner	Wildcat Landfill	Region III Subtotal
SOILS/LANDFILL CONTENTS															
NO ACTION											X				1
ACCESS RESTRICTION					X										1
Deed Restrictions					X										1
Land Use Restrictions															
Fencing														X	1
CONTAINMENT	X	X	X	X	X	X	X	X		X		X	X	X	12
Surface Controls	X		X			X								X	4
Grading	X					X								X	3
Revegetation						X								X	2
Cap	X	X	X	X	X	X	X	X		X			X	X	11
Clay Barrier		X	X			X				X					4
Multibarrier	X			X	X		X	X					X		6
Soil										X				X	2
Synthetic Membrane															0
REMOVAL/DISPOSAL			X			X									2
Excavation		X	X	X		X							X		5
Mechanical Excav.				X									X		2
Drum Removal		X		X										X	3
Consolidation															0
Disposal Onsite															0
RCRA Tyoe Landfill															0
Disposal Offsite						X									1
SOIL TREATMENT			X					X							2
Biological Treatment															0
Physical Treatment				X											1
Thermal Treatment				X											1
Incineration				X											1
Offsite Treatment															0
RCRA Incinerator															0
IN-SITU TREATMENT								X							1
Biodegradation															0
Vitrification															0
Physical Treatment			X					X						X	3
Solidification/fixation			X											X	2
Vapor Extraction								X							1

11/14/90

Appendix B2
Remedial Technologies Used at Landfill Sites

GENERAL RESPONSE ACTION/ Remedial Technologies Process Options	Region III Army Creek	Blosenski Landfill	Craig Farm	Delaware Sand	Dorney Road	Enterprise Avenue	Heleva Landfill	Henderson Road	Industrial Lane	Moyer Landfill	Reeser's Landfill	Stratsburg Landfill	Tybouts Corner	Wildcat Landfill	Region III Subtotal

GROUNDWATER AND LEACHATE															
NO ACTION											X				1
Attenuation Observation															0
MONITORING	X				X		X			X	X			X	6
INSTITUTIONAL CONTROLS														X	1
Alternate Water Supply		X					X		X					X	4
CONTAINMENT															0
Vertical Barriers															0
Slurry Wall															0
Horizontal Barriers															0
COLLECTION	X		X	X			X								4
Extraction	X		X	X			X								4
Extraction Wells	X			X			X								3
Ext/Injection Wells								X							1
Leachate Collection			X							X		X	X		4
Collection trench	X		X		X								X		4
Leachate Drain										X		X	X		3
Onsite Discharge															0
Aquifer ReInjection															0
Surface Discharge															0
Dewatering															0
Offsite Discharge															0
POTW															0
Land Application										X					1
TREATMENT				X				X		X					3
Biological Treatment							X								1
Activated Sludge							X								1
Chemical Treatment															0
Oxidation															0
Ion Exchange Treatment															0
Coagulant Addition															0
Metals Precipitation															0
PH Adjustment															0
Physical Treatment							X	X				X			3
Adsorption							X					X			2
Air Stripping							X	X							2
Sedimentation							X								1
Sand filtration															0
Flocculation															0
Lime pretreatment							X								1
Offsite Treatment												X			1
POTW												X			1

11/14/90

Appendix B2
Remedial Technologies Used at Landfill Sites

GENERAL RESPONSE ACTION/ Remedial Technologies Process Options	Region III														Region III Subtotal	
	Army Creek	Blosenski Landfill	Craig Farm	Delaware Sand	Dorney Road	Enterprise Avenue	Heleva Landfill	Henderson Road	Industrial Lane	Moyer Landfill	Reeser's Landfill	Stratsburg Landfill	Tybouts Corner	Wildcat Landfill		
LANDFILL GAS																
COLLECTION	X	X			X		X									4
Passive Systems	X	X					X									3
Pipe Vents																0
Trench Vents		X					X									2
Active Vents					X					X						2
Extraction Wells										X						1
Blowers										X						0
TREATMENT										X						1
Thermal Destruction										X						1
Flaring										X						0
Activated carbon																0
MONITORING		X					X			X						3
SURFACE WATER AND SEDIMENTS																
Stromwater controls																0
Diversion		X			X		X									3
Removal Disposal (sediments)																0
Excavation																0
Offsite Disposal (sediments)										X						1
Treatment																0
Solidification																0
Dewatering																0
Thermal treatment																0

11/14/90

Appendix B2
Remedial Technologies Used at Landfill Sites

GENERAL RESPONSE ACTION/ Remedial Technologies	Region IV Airco	Amnicola	Davie Landsfil 1	B.F. Goodrich	Hipps Road	Kassouf- Kimerling	Lees Lane	NW 58th St. LF	Newport Dumpsite	Powersville Landfill	Region IV Total
SOILS/LANDFILL CONTENTS											
NO ACTION											0
ACCESS RESTRICTION	X				X		X			X	4
Deed Restriction				X						X	2
Land Use Restriction	X	X		X	X						4
Fencing	X				X		X				3
CONTAINMENT	X		X	X	X		X	X			7
Surface Controls	X	X		X				X	X		5
Grading								X	X		2
Revegetation		X							X		2
Cap	X		X	X	X		X	X		X	8
Clay Barrier	X		X	X					X	X	5
Multibarrier	X										1
Soil					X						1
Synthetic Membrane											0
REMOVAL/DISPOSAL											0
Excavation	X	X		X		X					4
Mechanical Excav.	X	X									2
Drum Removal							X				1
Consolidation	X										1
Disposal Onsite			X			X					2
RCRA Type landfill			X								1
Disposal Offsite											0
SOIL TREATMENT											0
Biological Treatment											0
Physical Treatment											0
Thermal Treatment											0
Incineration											0
Offsite Treatment											0
RCRA Incinerator											0
IN-SITU TREATMENT											0
Biodegradation											0
Vitrification											0
Physical Treatment	X	X				X					3
Solidification/fixation		X				X					2
Vapor Extraction	X			X							2

Appendix B2
Remedial Technologies Used at Landfill Sites

GENERAL RESPONSE ACTION/ Remedial Technologies	Region IV Airco	Amnicol a Dump	Davie Landfill	B.F. Goodrich	Hipps Road	Kassouf- Kimerling	Lees Lane	NW 58th St. LF	Newport Dumpsite	Powersville Landfill	Region IV Total
GROUNDWATER AND LEACHATE											
NO ACTION											0
Attenuation											0
Observation											0
MONITORING	X	X		X	X			X	X	X	7
INSTITUTIONAL CONTROLS	X	X		X	X						4
Alternate Water Supply							X	X		X	3
CONTAINMENT											0
Vertical Barriers											0
Slurry Wall											0
Horizontal Barriers											0
COLLECTION	X		X	X	X						4
Extraction	X		X	X	X						4
Extraction Wells	X			X	X						3
Ext/Injection Wells											0
Leachate Collection	X		X	X				X			4
Collection trench								X			1
Leachate Drain	X		X								2
Onsite Discharge											0
Aquifer ReInjection											0
Surface Discharge											0
Dewatering											0
Offsite Discharge											0
POTW											0
Land Application											0
TREATMENT	X			X				X			3
Biological Treatment	X										1
Activated Sludge											0
Chemical Treatment											0
Oxidation											0
Ion Exchange Treatment											0
Coagulant Addition											0
Metals Percipitation											0
pH Adjustment											0
Physical Treatment	X			X				X			3
Adsorption	X			X							2
Air Stripping	X			X				X			3
Sedimentation											0
Sand filtration											0
Flocculation											0
Lime pretreatment											0
Offsite Treatment			X		X						2
POTW			X		X						2

11/14/90

Appendix B2
Remedial Technologies Used at Landfill Sites

GENERAL RESPONSE ACTION/ Remedial Technologies	Region IV	Airco	Amnicola	Davie	B.F.	Hipps	Kassouf-	Lees	NW 58th	Newport	Powersville	Region IV
Process Options	Landfill	Dump	Landfill	Goodrich	Road	Kimerling	Lane	St. LF	Dumpsite	Landfill	Total	
LANDFILL GAS												
COLLECTION								X	X			2
Passive Systems								X	X			2
Pipe Vents												0
Trench Vents								X	X			2
Active Vents												0
Extraction Wells												0
Blowers												0
TREATMENT												0
Thermal Destruction												0
Flaring												0
Activated carbon												0
MONITORING										X		1
SURFACE WATER AND SEDIMENTS												
Stormwater controls										X		1
Diversion												0
Removal Disposal (sediments)												0
Excavation												0
Offsite Disposal (sediments)												0
Treatment				X								1
Solidification				X								1
Dewatering				X								1
Thermal treatment												0

Appendix B2
Remedial Technologies Used at Landfill Sites

GENERAL RESPONSE ACTION/ Remedial Technologies Process Options	Region V		Cemetery	Cliff/Dow	Coshocton	E. H.	Forest	Fort	Industrial	Ionia	Kummer	Lake	Liquid	Marion	Mason	Metamora	Miami	Mid-State	New
	Belvidere	Bowers	Dump	Dump	Landfill	Schilling	Waste	Wayne	Excess	City	Landfill	Sandy Jo	Disposal	Bragg	County	Landfill	County	Landfill	Lime
SOILS/LANDFILL CONTENTS																			
NO ACTION																			
ACCESS RESTRICTION	X	X		X	X	X	X	X		X	X	X		X	X		X	X	
Deed Restriction	X			X	X	X	X	X			X	X					X	X	
Land Use Restrictions		X		X					X	X					X		X	X	
Fencing	X	X			X	X		X	X	X	X			X	X		X	X	X
CONTAINMENT	X	X			X	X	X	X	X	X							X	X	
Surface Controls		X		X	X	X	X			X	X			X			X	X	
Grading		X			X	X					X			X			X	X	
Revegetation				X	X						X						X	X	
Cap	X	X		X	X	X	X	X	X	X	X	X	X	X	X		X	X	X
Clay Barrier		X				X								X	X		X	X	
Multibarrier							X		X				X	X	X				X
Soil		X		X	X			X		X		X			X			X	
Synthetic Membrane																			
REMOVAL/DISPOSAL		X				X													
Excavation		X	X	X		X	X				X					X	X		X
Mechanical Excav.			X													X			
Drum Removal			X				X	X											
Consolidation						X		X									X		
Disposal Onsite		X											X						
RCRA Type Landfill																			
Disposal Offsite		X	X	X						X									
SOIL TREATMENT	X															X			
Biological Treatment				X												X			
Physical Treatment							X												
Thermal Treatment				X			X	X									X		
Incineration				X			X	X								X			
Offsite Treatment																			
RCRA Incineration																			
IN-SITU TREATMENT										X									
Biodegradation																			
Vitrification										X									
Physical Treatment													X				X		
Solidification/fixation													X						
Vapor Extraction																		X	

Appendix B2
Remedial Technologies Used at Landfill Sites

GENERAL RESPONSE ACTION/ Remedial Technologies Process Options	Region V Belvidere Landfill	Bowers Landfill	Cemetery Dump	Cliff/Dow Dump	Coshocton Landfill	E. H. Schilling	Forest Waste	Fort Wayne	Industrial Excess	Ionia City	Kummer Landfill	Lake Sandy Jo	Liquid Disposal	Marion Bragg	Mason County	Metamora Landfill	Miami County	Mid-State Landfill	New Lime
GROUNDWATER AND LEACHATE																			
NO ACTION																			
Attenuation																			
Observation																			
MONITORING		X		X	X	X	X	X	X		X	X			X		X		X
INSTITUTIONAL CONTROLS				X						X		X			X		X	X	
Alternate Water Supply									X		X	X		X			X		
CONTAINMENT													X						X
Vertical Barriers													X						
Slurry Wall						X	X						X						
Horizontal Barriers																			
COLLECTION	X				X	X		X	X			X	X				X		
Extraction	X				X	X		X	X			X	X				X		X
Extraction Wells								X	X				X				X		X
Ext/Injection Wells																			
Leachate Collection							X					X						X	
Collection trench																			
Leachate Drain							X					X						X	
Onsite Discharge																			
Aquifer ReInjection																			
Surface Discharge																			
Dewatering						X	X												
Offsite Discharge																			
POIW																			
Land Application									X										X
TREATMENT	X					X	X												X
Biological Treatment																			
Activated Sludge																			X
Chemical Treatment													X						
Oxidation																			
Ion Exchange Treatment													X						
Coagulant Addition																			X
Metals Percipitation																			
pH Adjustment																		X	X
Physical Treatment	X					X			X								X		X
Adsorption						X			X				X						
Air Stripping	X					X			X										
Sedimentation									X				X						
Sand filtration									X										
Flocculation									X										
Lime pretreatment																			
Offsite Treatment							X										X	X	
POIW							X										X	X	

Appendix B2
Remedial Technologies Used at Landfill Sites

GENERAL RESPONSE ACTION/ Remedial Technologies Process Options	Region V Belvidere Landfill	Bowers Landfill	Cemetery Dump	Cliff/Dow Dump	Coshocton Landfill	E. H. Schilling	Forest Waste	Fort Wayne	Industrial Excess	Ionia City	Kummer Landfill	Lake Sandy Jo	Liquid Disposal	Marion Bragg	Mason County	Metamora Landfill	Miami County	Mid-State Landfill	New Lime
LANDFILL GAS																			
COLLECTION					X				X		X								
Passive Systems											X								
Pipe Vents																			
Trench Vents											X								
Active Vents									X										X
Extraction Wells									X										X
Blowers									X										
TREATMENT									X										
Thermal Destruction									X										X
Flaring									X										X
Activated carbon																			
MONITORING		X		X							X								X
SURFACE WATER AND SEDIMENTS																			
Stormwater controls																			
Diversion																			
Removal Disposal (sediments)																			
Excavation																			
Offsite Disposal (sediments)																			
Treatment																			
Solidification																			X
Dewatering																			X
Thermal treatment																			

11/14/90

Appendix B2
Remedial Technologies Used at Landfill Sites

GENERAL RESPONSE ACTION/ Remedial Technologies Process Options	Region V		Continued				Region V
	Northside	Oak	Schmalz	Spiegelberg	Wauconda	Windom	Total
	IN	Grove	Dump	Landfill	Sand	Dump	
SOILS/LANDFILL CONTENTS							
NO ACTION							0
ACCESS RESTRICTION	X	X			X		17
Deed Restriction	X	X					12
Land Use Restrictions							7
Fencing		X			X		15
CONTAINMENT	X	X			X		12
Surface Controls		X			X	X	13
Grading					X	X	9
Revegetation		X			X	X	7
Cap	X	X	X		X	X	22
Clay Barrier					X	X	8
Multibarrier	X	X					8
Soil			X				9
Synthetic Membrane							0
REMOVAL/DISPOSAL							2
Excavation			X	X			10
Mechanical Excav.			X				3
Drum Removal							3
Consolidation							4
Disposal Onsite							2
RCRA Type Landfill							0
Disposal Offsite			X	X			6
SOIL TREATMENT							3
Biological Treatment							1
Physical Treatment							1
Thermal Treatment							4
Incineration							4
Offsite Treatment				X			1
RCRA Incineration				X			1
IN-SITU TREATMENT							1
Biodegradation							0
Vitrification							1
Physical Treatment							2
Solidification/fixation							1
Vapor Extraction							1

11/14/90

Appendix B2
Remedial Technologies Used at Landfill Sites

GENERAL RESPONSE ACTION/ Remedial Technologies Process Options	Region V		Continued					Region V Total
	Northside IN	Oak Grove	Schmalz Dump	Spiegelberg Landfill	Wauconda Sand	Windom Dump		

GROUNDWATER AND LEACHATE								
NO ACTION						X		1
Attenuation								0
Observation								0
MONITORING	X	X	X		X	X		17
INSTITUTIONAL CONTROLS								
Alternate Water Supply			X					6
CONTAINMENT								
Vertical Barriers								3
Slurry Wall								3
Horizontal Barriers								0
COLLECTION					X			9
Extraction					X			10
Extraction Wells								5
Ext/Injection Wells								0
Leachate Collection	X				X			5
Collection trench	X							1
Leachate Drain	X				X			5
Onsite Discharge								0
Aquifer Reinjection								0
Surface Discharge								0
Dewatering								2
Offsite Discharge								0
POTW								0
Land Application								0
TREATMENT								
Biological Treatment	X							2
Activated Sludge	X							1
Chemical Treatment	X							3
Oxidation	X							1
Ion Exchange Treatment								1
Coagulant Addition								0
Metals Precipitation	X							2
pH Adjustment								0
Physical Treatment	X							7
Adsorption	X							5
Air Stripping								4
Sedimentation								1
Sand filtration								1
Flocculation								1
Lime pretreatment								0
Offsite Treatment					X			4
POTW					X			4

11/14/90

Appendix B2
Remedial Technologies Used at Landfill Sites

GENERAL RESPONSE ACTION/ Remedial Technologies Process Options	Region V Northside	Continued Oak Grove	Schmalz Dump	Spiegelberg Landfill	Wauconda Sand	Windom Dump	Region V Total

LANDFILL GAS							
COLLECTION							3
Passive Systems							1
Pipe Vents							0
Trench Vents							1
Active Vents							2
Extraction Wells							2
Blowers							1
TREATMENT							1
Thermal Destruction					X		3
Flaring					X		3
Activated carbon							0
MONITORING		X			X		6

SURFACE WATER AND SEDIMENTS							
Stormwater controls							0
Diversion	X						1
Removal Disposal (sediments)							1
Excavation							1
Offsite Disposal (sediments)							0
Treatment							2
Solidification							2
Dewatering							0
Thermal treatment							0

11/14/90

Appendix B2
Remedial Technologies Used at Landfill Sites

GENERAL RESPONSE ACTION/ Remedial Technologies Process Options	Region VI					Region V Total
	Bayou Sorrel	Cecil Lindsey	Cleve Reber	Compass Industries	Industrial Waste	
SOILS/LANDFILL CONTENTS						
NO ACTION						0
ACCESS RESTRICTION	X	X		X	X	4
Deed Restriction						0
Land Use Restrictions					X	1
Fencing	X	X		X	X	4
CONTAINMENT	X			X		2
Surface Controls	X					1
Grading	X					1
Revegetation						0
Cap	X			X	X	3
Clay Barrier						0
Multibarrier	X				X	2
Soil						0
Synthetic Membrane						0
REMOVAL/DISPOSAL						0
Excavation		X	X		X	3
Mechanical Excav.			X		X	2
Drum Removal		X	X		X	3
Consolidation	X				X	2
Disposal Onsite						0
RCRA Type Landfill						0
Disposal Offsite					X	1
SOIL TREATMENT						0
Biological Treatment						0
Physical Treatment						0
Thermal Treatment			X			1
Incineration			X			1
Offsite Treatment						0
RCRA Incineration						0
IN-SITU TREATMENT						0
Biodegradation						0
Vitrification						0
Physical Treatment			X		X	2
Solidification/fixation			X		X	2
Vapor Extraction						0

Appendix B2
Remedial Technologies Used at Landfill Sites

GENERAL RESPONSE ACTION/ Remedial Technologies Process Options	Region VI Bayou Sorrel	Cecil Lindsey	Cleve Reber	Compass Industries	Industrial Waste	Region VI Total
GROUNDWATER AND LEACHATE						
NO ACTION			X			1
Attenuation						0
Observation						0
MONITORING	X	X	X		X	4
INSTITUTIONAL CONTROLS					X	1
Alternate Water Supply						0
CONTAINMENT	X					1
Vertical Barriers	X				X	2
Slurry Wall	X				X	2
Horizontal Barriers						0
COLLECTION				X		1
Extraction				X		1
Extraction Wells						0
Ext/Injection Wells						0
Leachate Collection					X	1
Collection trench						0
Leachate Drain					X	1
Onsite Discharge						0
Aquifer Reinjection						0
Surface Discharge						0
Dewatering						0
Offsite Discharge						0
POTW						0
Land Application						0
TREATMENT				X	X	2
Biological Treatment						0
Activated Sludge						0
Chemical Treatment						0
Oxidation						0
Ion Exchange Treatment						0
Coagulant Addition						0
Metals Precipitation						0
pH Adjustment						0
Physical Treatment						0
Adsorption						0
Air Stripping						0
Sedimentation						0
Sand filtration						0
Flocculation						0
Lime pretreatment						0
Offsite Treatment						0
POTW						0

11/14/90

Appendix B2
Remedial Technologies Used at Landfill Sites

GENERAL RESPONSE ACTION/ Remedial Technologies Process Options	Region VI Bayou Sorrel	Cecil Lindsey	Cleve Reber	Compass Industries	Industrial Waste	Region VI Total	
=====							
LANDFILL GAS							
=====							
COLLECTION	X					1	
Passive Systems	X					1	
Pipe Vents						0	
Trench Vents	X					1	
Active Vents						0	
Extraction Wells						0	
Blowers						0	
TREATMENT						0	
Thermal Destruction						0	
Flaring						0	
Activated carbon						0	
MONITORING						0	
=====							
SURFACE WATER AND SEDIMENTS							
=====							
Stormwater controls					X	1	
Diversion						0	
Removal Disposal (sediments)						0	
Excavation						0	
Offsite Disposal (sediments)						0	
Treatment						0	
Solidification						0	
Dewatering						0	
Thermal treatment						0	
=====							

11/14/90

Appendix B2
Remedial Technologies Used at Landfill Sites

GENERAL RESPONSE ACTION/ Remedial Technologies Process Options	Region VII Arkansas City	Conservation Chemical	Doepke Disposal	Fulbright/Sac River	Lawrence Todtz	Region VII Total	Region VIII Marshall Landfill	Region VIII Total
SOILS/LANDFILL CONTENTS								
NO ACTION	X					1		0
ACCESS RESTRICTION			X		X	2	X	1
Deed Restrictions			X		X	2		0
Land Use Restrictions				X		1		0
Fencing					X	1	X	1
CONTAINMENT			X			1		0
Surface Controls		X			X	2	X	1
Grading		X				1	X	1
Revegetation					X	1	X	1
Cap		X	X		X	3		0
Clay Barrier			X			1		0
Multibarrier			X			1		0
Soil		X			X	2		0
Synthetic Membrane						0		0
REMOVAL/DISPOSAL		X		X		2		0
Excavation				X		1		0
Mechanical Excav.						0		0
Drum Removal				X		1		0
Consolidation						0		0
Disposal Onsite	X					1		0
RCRA Type Landfill						0		0
Disposal Offsite		X		X		2		0
SOIL TREATMENT						0		0
Biological Treatment						0		0
Physical Treatment						0		0
Thermal Treatment						0		0
Incineration						0		0
Offsite Treatment						0		0
RCRA Incinerator						0		0
IN-SITU TREATMENT						0		0
Biodegradation						0		0
Vitrification						0		0
Physical Treatment						0		0
Solidification/fixation						0		0
Vapor Extraction						0		0

Appendix B2
Remedial Technologies Used at Landfill Sites

GENERAL RESPONSE ACTION/ Remedial Technologies Process Options	Region VII Arkansas City	Conservation Chemical	Doepke Disposal	Fulbright/Sac River	Lawrence Todtz	Region VII Total	Region VIII Marshall Landfill	Region VIII Total
GROUND WATER AND LEACHATE								
NO ACTION	X			X		2		0
Attenuation						0		0
Observation				X		1		0
MONITORING		X	X	X	X	4		0
INSTITUTIONAL CONTROLS						0		0
Alternate Water Supply					X	1		0
CONTAINMENT			X			1		0
Vertical Barriers			X			1		0
Slurry Wall			X			1		0
Horizontal Barriers						0		0
COLLECTION		X				1		0
Extraction		X				1		0
Extraction Wells		X				1		0
Ext/Injection Wells						0		0
Leachate Collection						0	X	1
Collection trench						0		0
Leachate Drain						0	X	1
Onsite Discharge						0		0
Aquifer Reinjection						0		0
Surface Discharge			X			0		0
Dewatering						1	X	1
Offsite Discharge						0		0
POTW						0		0
Land Application						0		0
TREATMENT		X				1	X	1
Biological Treatment		X				1		0
Activated Sludge						0		0
Chemical Treatment		X				1		0
Oxidation						0		0
Ion Exchange Treatment						0		0
Coagulant Addition						0		0
Metals Precipitation		X				1		0
pH Adjustment						0		0
Physical Treatment		X				1	X	1
Adsorption		X				1	X	1
Air Stripping						0	X	1
Sedimentation						0	X	1
Sand Filtration		X				1		0
Flocculation						0		0
Lime pretreatment						0		0
Offsite Treatment			X			1		0
POTW			X			1		0

11/14/90

Appendix B2
Remedial Technologies Used at Landfill Sites

GENERAL RESPONSE ACTION/ Remedial Technologies Process Options	Region VII Arkansas City	Conservation Chemical	Doepke Disposal	Fulbright/Sac River	Lawrence Todtz	Region VII Total	Region VIII Marshall Landfill	Region VIII Total
=====								
LANDFILL GAS								
=====								
COLLECTION						0		0
Passive Systems						0		0
Pipe Vents						0		0
Trench Vents						0		0
Active Vents						0		0
Extraction Wells						0		0
Blowers						0		0
TREATMENT						0		0
Thermal Destruction						0		0
Flaring						0		0
Activated carbon						0		0
MONITORING						0		0
=====								
SURFACE WATER AND SEDIMENTS								
=====								
Stormwater controls						0	X	1
Diversion						0		0
Removal Disposal (sediments)						0		0
Excavation						0		0
Offsite Disposal (sediments)						0		0
Treatment						0		0
Solidification						0		0
Dewatering						0		0
Thermal treatment						0		0
=====								

GENERAL RESPONSE ACTION/ Remedial Technologies Process Options	Region IX Jibboom Junkyard	Operating Industries	Ordot Disposal	Region IX Total

SOILS/LANDFILL CONTENTS				
NO ACTION			X	1
ACCESS RESTRICTION				0
Deed Restrictions				0
Land Use Restrictions				0
Fencing				0
CONTAINMENT				0
Surface Controls				0
Grading				0
Revegetation				0
Cap				0
Clay Barrier				0
Multibarrier				0
Soil				0
Synthetic Membrane				0
REMOVAL/DISPOSAL				0
Excavation	X			1
Mechanical Excav.	X			1
Drum Removal				0
Consolidation				0
Disposal Onsite				0
RCRA Type Landfill				0
Disposal Offsite	X			1
SOIL TREATMENT				0
Biological Treatment				0
Physical Treatment				0
Thermal Treatment				0
Incineration				0
Offsite Treatment				0
RCRA Incinerator				0
IN-SITU TREATMENT				0
Biodegradation				0
Vitrification				0
Physical Treatment				0
Solidification/fixation				0
Vapor Extraction				0

GENERAL RESPONSE ACTION/ Remedial Technologies Process Options	Region IX Jibboom Junkyard	Operating Industries	Ordot Disposal	Region IX Total
=====				
GROUNDWATER AND LEACHATE				
NO ACTION				0
Attenuation				0
Observation				0
MONITORING				0
INSTITUTIONAL CONTROLS				0
Alternate Water Supply				0
CONTAINMENT				0
Vertical Barriers				0
Slurry Wall				0
Horizontal Barriers				0
COLLECTION				0
Extraction				0
Extraction Wells				0
Ext/Injection Wells				0
Leachate Collection				0
Collection trench				0
Leachate Drain				0
Onsite Discharge				0
Aquifer Reinjection				0
Surface Discharge				0
Dewatering				0
Offsite Discharge				0
POTW				0
Land Application				0
TREATMENT		X		1
Biological Treatment				0
Activated Sludge				0
Chemical Treatment		X		1
Oxidation				0
Ion Exchange Treatment				0
Coagulant Addition		X		1
Metals Precipitation				0
pH Adjustment				0
Physical Treatment		X		1
Adsorption		X		1
Air Stripping		X		1
Sedimentation				0
Sand Filtration				0
Flocculation				0
Lime pretreatment				0
Offsite Treatment				0
POTW				0
=====				

11/14/90

Appendix B2

GENERAL RESPONSE ACTION/ Remedial Technologies Process Options	Region IX Jibboom Junkyard	Operating Industries	Ordot Disposal	Region IX Total
=====				
LANDFILL GAS				
COLLECTION				
Passive Systems				0
Pipe Vents				0
Trench Vents				0
Active Vents		X		1
Extraction Wells		X		1
Blowers				0
TREATMENT				
Thermal Destruction		X		1
Flaring		X		1
Activated carbon				0
MONITORING		X		1
=====				
SURFACE WATER AND SEDIMENTS				
Stormwater controls				
Diversion			X	1
Removal Disposal (sediments)				0
Excavation				0
Offsite Disposal (sediments)				0
Treatment				0
Solidification				0
Dewatering				0
Thermal treatment				0
=====				

11/14/90

Appendix B2
Remedial Technologies Used at Landfill Sites

GENERAL RESPONSE ACTION/ Remedial Technologies Process Options	Region X Colbert Landfill	Commencement Bay	Northside WA	Region X Total	GRAND TOTAL
SOILS/LANDFILL CONTENTS					
NO ACTION				0	3
ACCESS RESTRICTION			X	1	40
Deed Restriction		X		1	20
Land Use Restrictions		X		1	16
Fencing				0	36
CONTAINMENT			X	1	54
Surface Controls				0	35
Grading				0	22
Revegetation				0	16
Cap	X		X	2	68
Clay Barrier				0	25
Multibarrier		X		1	30
Soil				0	17
Synthetic membrane				0	3
REMOVAL/DISPOSAL				0	11
Excavation				0	30
Mechanical Excav.				0	11
Drum Removal				0	11
Consolidation				0	8
Disposal Onsite				0	5
RCRA Type Landfill				0	1
Disposal Offsite				0	13
SOIL TREATMENT				0	5
Biological Treatment				0	1
Physical Treatment				0	2
Thermal Treatment				0	8
Incineration				0	7
Offsite Treatment				0	1
RCRA Incinerator				0	1
IN-SITU TREATMENT				0	3
Biodegradation				0	1
Vitrification				0	1
Physical Treatment				0	12
Solidification/fixation				0	8
Vapor Extraction				0	5

Appendix B2
Remedial Technologies Used at Landfill
Sites

GENERAL RESPONSE ACTION/ Remedial Technologies Process Options	Region X Colbert Landfill	Commencement Bay	Northside WA	Region X Total	GRAND TOTAL
GROUNDWATER AND LEACHATE					
NO ACTION				0	6
Attenuation				0	1
Observation				0	1
MONITORING	X	X	X	3	59
INSTITUTIONAL CONTROLS	X	X	X	3	21
Alternate Water Supply	X	X	X	3	24
CONTAINMENT				0	12
Vertical Barriers				0	13
Slurry Wall				0	13
Horizontal Barriers				0	1
COLLECTION	X	X	X	3	40
Extraction	X	X	X	3	43
Extraction Wells	X	X	X	3	24
Ext/Injection Wells				0	2
Leachate Collection		X		1	27
Collection trench				0	10
Leachate Drain		X		1	19
Onsite Discharge				0	0
Aquifer Reinjection				0	1
Surface Discharge				0	0
Dewatering				0	6
Offsite Discharge				0	3
POTW	X	X	X	3	6
Land Application				0	1
TREATMENT	X	X	X	3	32
biological Treatment				0	9
Activated Sludge				0	2
Chemical Treatment				0	12
Oxidation				0	2
Ion Exchange Treatment				0	2
Coagulant Addition				0	2
Metals Precipitation				0	8
pH Adjustment				0	1
Physical Treatment		X		1	29
Adsorption				0	18
Air Stripping	X	X	X	3	23
Sedimentation				0	5
Sand Filtration				0	2
Flocculation				0	3
Lime pretreatment				0	2
Offsite Treatment				0	15
POTW				0	15

11/14/90

Appendix B2
Remedial Technologies Used at Landfill
Sites

GENERAL RESPONSE ACTION/ Remedial Technologies Process Options	Region X Colbert Landfill	Commencement Bay	Northside WA	Region X Total	GRAND TOTAL
=====					
LANDFILL GAS					
COLLECTION					
Passive Systems			X	1	17
Pipe Vent				0	1
Trench Vents				0	10
Active Vents				0	11
Extraction Wells		X		1	9
Blowers				0	5
TREATMENT					
Thermal Destruction				0	8
Flaring		X		1	12
Activated carbon				0	9
MONITORING	X	X	X	3	21
=====					
SURFACE WATER AND SEDIMENTS					
Stormwater controls					
Diversion				0	10
Removal Disposal (sediments)				0	5
Excavation				0	5
Offsite Disposal (sediments)				0	2
Treatment				0	4
Solidification				0	4
Dewatering				0	4
Thermal treatment				0	1
=====					

**Appendix B-3
BREAKDOWN BY REGION OF REMEDIAL TECHNOLOGIES USED AT LANDFILL SITES**

Environmental Media	General Response Actions	Remedial Technologies	Region 1 (10 sites)	Region 2 (16 sites)	Region 3 (14 sites)	Region 4 (10 sites)	Region 5 (25 sites)	Region 6 (5 sites)	Region 7 (5 sites)	Region 8 (1 site)	Region 9 (3 sites)	Region 10 (3 sites)	Total (92 sites)	
Soils/ Landfill Contents	No Action		0	0	1	0	0	0	1	0	1	0	3	
	Access Restriction	Deed Restrictions	2	0	1	2	12	0	2	0	0	0	1	20
		Fencing	3	9	0	3	15	4	1	1	1	0	0	36
		Land Use Restrictions	1	0	1	4	7	1	1	1	0	0	1	16
	Containment	Surface Controls	3	6	4	5	13	1	2	1	1	0	0	35
		Cap	6	13	11	8	22	3	1	0	0	1	2	68
Soils/Hots Spots	Removal/Disposal	Excavation	4	2	5	4	10	3	1	0	1	0	30	
		Disposal Onsite	0	0	0	2	2	0	1	0	0	0	0	5
		Disposal Offsite	1	1	1	0	6	1	2	0	0	1	0	13
	Onsite Treatment	Thermal Treatment	1	1	1	0	4	1	0	0	0	0	0	8
	In Situ Treatment	Biological Treatment	0	0	0	0	1	0	0	0	0	0	0	1
		Physical Treatment	1	1	3	3	2	2	0	0	0	0	0	12
Offsite Treatment	Thermal Destruction	0	0	0	0	1	0	0	0	0	0	0	1	
Groundwater and Leachate	No action		0	1	1	0	1	1	2	0	0	0	6	
	Institutional Controls	Alternate Water Supply	5	2	4	3	6	0	1	0	0	3	24	
	Containment	Vertical Barriers	0	7	0	0	3	2	1	0	0	0	0	13
		Horizontal Barriers	1	0	0	0	0	0	0	0	0	0	0	1
	Collection	Extraction	7	13	4	4	10	1	1	0	0	0	3	43
Leachate Collection		3	8	4	4	5	1	0	1	1	0	1	27	

**Appendix B-3
BREAKDOWN BY REGION OF REMEDIAL TECHNOLOGIES USED AT LANDFILL SITES**

Page 2 of 2

Environmental Media	General Response Actions	Remedial Technologies	Region 1 (10 sites)	Region 2 (16 sites)	Region 3 (14 sites)	Region 4 (10 sites)	Region 5 (25 sites)	Region 6 (5 sites)	Region 7 (5 sites)	Region 8 (1 site)	Region 9 (3 sites)	Region 10 (3 sites)	Total (92 sites)	
Groundwater and Leachate (Continued)	Treatment	Biological Treatment	1	3	1	1	2	0	1	0	0	0	9	
		Chemical Treatment	3	4	0	0	3	0	1	0	1	0	12	
		Physical Treatment	4	8	3	3	7	0	1	1	1	1	29	
		Offsite Treatment (at POTW)	1	6	1	2	4	0	1	0	0	0	15	
	Disposal	Onsite Discharge	0	0	0	0	0	0	0	0	0	0	0	
		Offsite Discharge	1	2	0	0	0	0	0	0	0	0	3	
	Monitoring	Monitoring Wells	7	11	6	7	17	4	4	0	0	3	59	
Landfill Gas	Collection	Passive Vents	4	5	3	2	1	1	0	0	0	0	17	
		Active Systems	1	5	2	0	2	0	0	0	0	1	0	11
	Treatment	Thermal Destruction	2	5	1	0	3	0	0	0	0	1	0	12
		Activated Carbon	0	3	0	0	0	0	0	0	0	0	0	3
	Monitoring	Monitoring wells	2	5	3	1	6	0	0	0	0	1	3	21
Surface Water and Wetlands Sediments	Containment	Stormwater Controls	1	5	0	1	1	1	0	1	1	0	10	
	Removal Disposal	Excavation	1	3	0	0	1	0	0	0	0	0	0	5
		Offsite Disposal	0	1	1	0	0	0	0	0	0	0	0	2
	Treatment	Solidification	1	0	0	1	2	0	0	0	0	0	0	4
		Dewatering	1	2	0	1	0	0	0	0	0	0	0	4
		Thermal Treatment	0	1	0	0	0	0	0	0	0	0	1	

United States
Environmental Protection
Agency

Center for Environmental Research
Information
Cincinnati, OH 45268

Official Business
Penalty for Private Use, \$300

Please make all necessary changes on the above label,
detach or copy, and return to the address in the upper
left-hand corner.

If you do not wish to receive these reports CHECK HERE ~;
detach, or copy this cover, and return to the address in the
upper left-hand corner.

EPA/540-P-91/001